

# MASON RIDGE ENTRANCE MONUMENT PLANS

LOCATED IN  
HARNETT COUNTY, NORTH CAROLINA  
ESP PROJECT # 24-01007

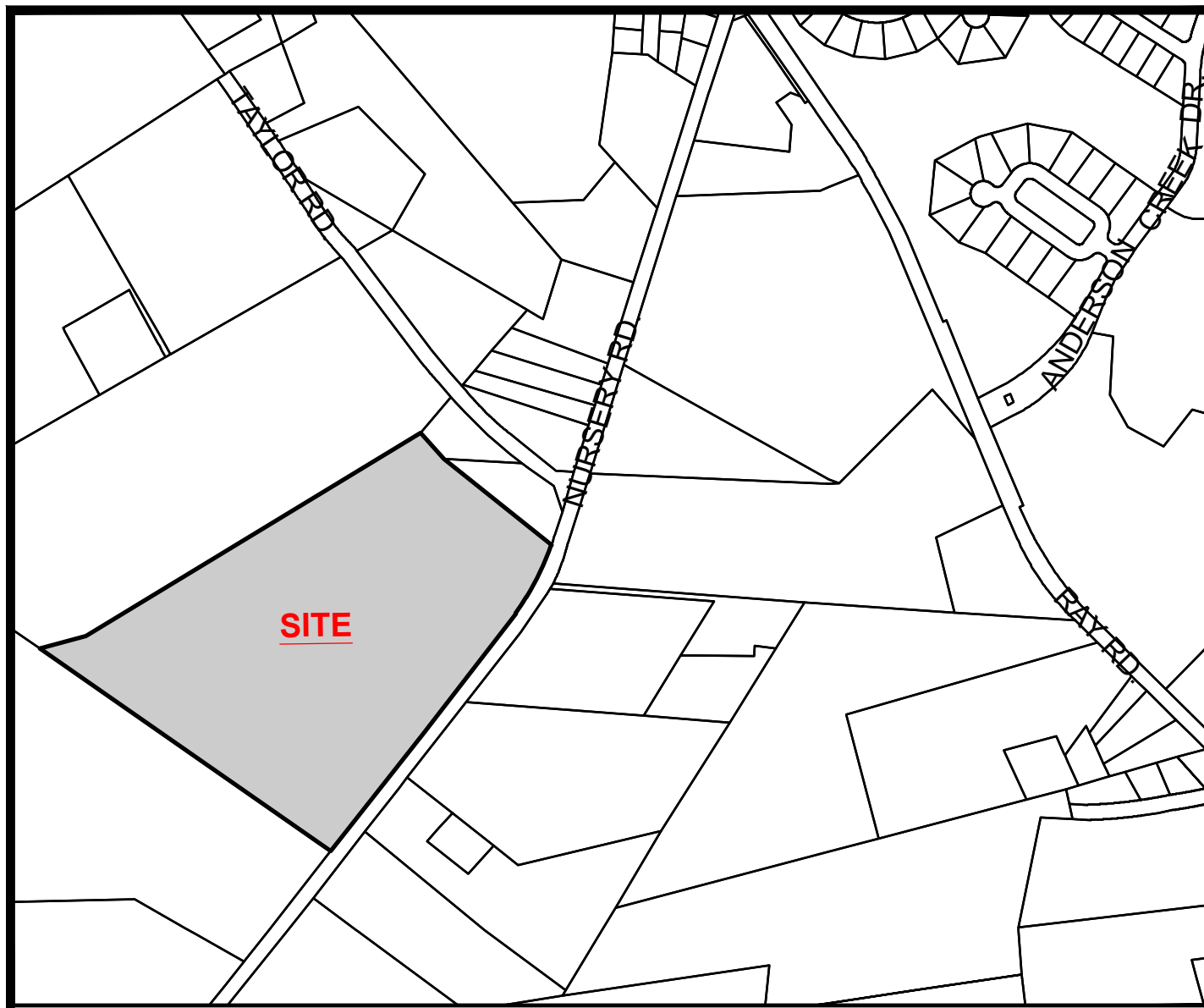

VICINITY MAP

SCALE: NTS

SHEET INDEX		
SHEET NO.	SHEET NAME	ORIGINAL DATE
COV	COVER	9/10/2024
H1.0	SITE LAYOUT PLAN	9/10/2024
H2.0	ENTRANCE MONUMENT CONCEPTUAL ELEVATION	9/10/2024
H2.1	ENTRANCE MONUMENT DETAILS	9/10/2024
H2.2	DECORATIVE MASONRY DETAILS	9/10/2024
L1.0	PLANTING PLAN	9/10/2024
S-1	STRUCTURAL PLANS	9/10/2024
S-2	STRUCTURAL PLANS	9/10/2024



ILLUSTRATIVE ELEVATION  
(NTS)

**D·R·HORTON®**  
*America's Builder*

LANDSCAPE ARCHITECT: ESP ASSOCIATES, INC.  
ADDRESS: 2200 GATEWAY CENTRE BLVD.  
STE. 216  
MORRISVILLE, NC 27560  
PHONE: (919) 678-1070  
FAX: (919) 677-1252  
CONTACT: EMILY ROTHROCK, PLA

DEVELOPER: D.R. HORTON  
ADDRESS: 2000 AERIAL CENTER PKWY  
SUITE 110A  
MORRISVILLE, NC 27560  
PHONE: (919) 460-2999  
CONTACT: ROBERT STUART

REVIEW AGENCY: HARNETT COUNTY PLANNING DEPARTMENT  
ADDRESS: 420 MCKINNEY PKWY  
LILLINGTON, NC 27546  
PHONE: 910 893-7525

THIS SET IS CURRENT THROUGH SHEET DATE 09/10/2024



FOR AGENCY  
REVIEW ONLY

NO.	DATE	REVISION	BY

COVER  
MASON RIDGE - ENTRANCE MONUMENT  
CONSTRUCTION DOCUMENTS  
D.R. HORTON  
HARNETT COUNTY, NC

PROJECT INFORMATION	
PROJECT MANAGER:	MS
DESIGNED BY:	MS
DRAWN BY:	BA
PROJECT NUMBER:	24-01007
ORIGINAL DATE:	09/10/2024

SHEET: **COV**

S:\RP\10024-Projects\24-01007 - Mason Ridge (DR Horton)\24-01007\Monuments\Sheets\24-01007\MON\_COV.dwg\_COVER.dwg

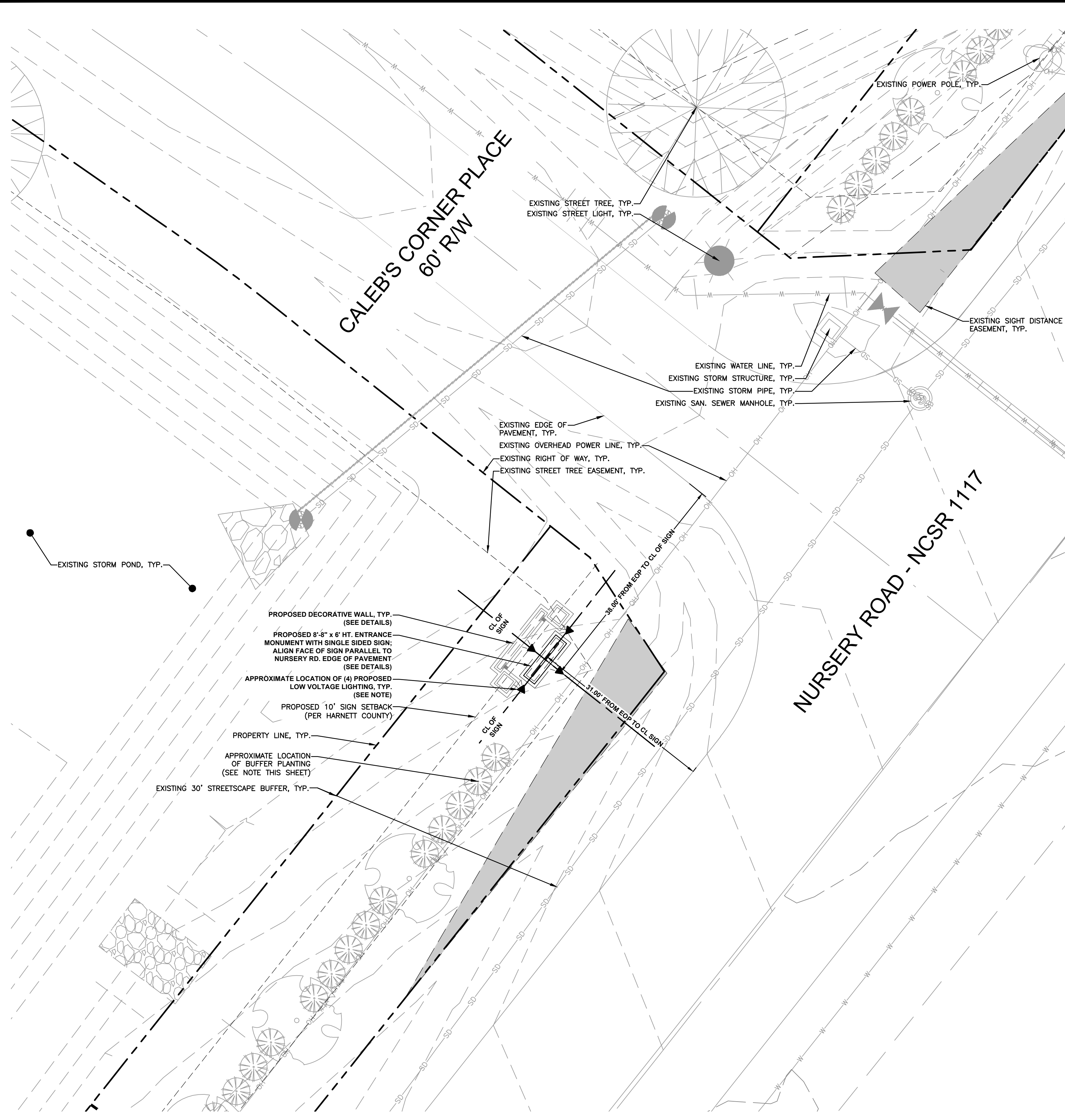

**ENTRANCE MONUMENT LAYOUT PLAN**

**GRAPHIC SCALE**

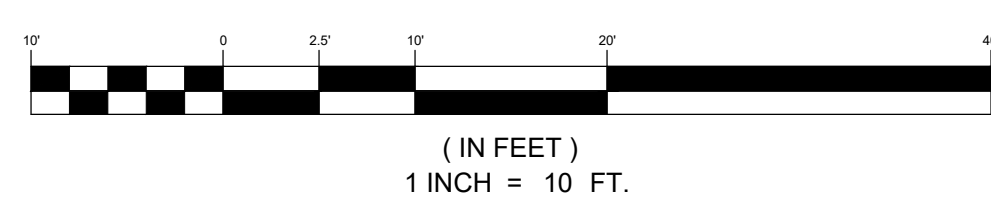

**SITE PLAN NOTES:**

1. BASE INFORMATION PROVIDED BY ACTUAL CAD FILES "MASON RIDGE\_CONSTRUCTION CAD FILE" DATED 7/19/2024 PROVIDED BY GREEN MOUNTAIN ENGINEERING.
2. PIN: 0505-35-1652
3. PLAN AND DETAILS SHOWN FOR DIMENSIONAL AND MATERIAL PURPOSES ONLY.
4. ALL DETAILED STRUCTURAL, REINFORCEMENT, ELECTRICAL DESIGN, AND HARDWARE BY OTHERS.
5. CONTRACTOR SHALL OBTAIN AS-BUILTS OF ALL EXISTING CONDITIONS AND UTILITIES AND VERIFY LAYOUT IN FIELD PRIOR TO START OF CONSTRUCTION.
6. CONTRACTOR SHALL ENSURE ALL APPLICABLE CODES AND PERMIT REQUIREMENTS ARE MET.
7. OVERHEAD LINES ARE SHOWN FOR INFORMATIONAL PURPOSES ONLY. FIELD VERIFY POWER POLE LOCATIONS WITH PROPOSED IMPROVEMENTS PRIOR TO CONSTRUCTION.
8. CONTRACTOR SHALL VERIFY ALL UTILITY LOCATIONS PRIOR TO INSTALLATION OF IMPROVEMENTS AND NOTIFY LANDSCAPE ARCHITECT IMMEDIATELY IF FIELD CONDITIONS WARRANT ADJUSTMENT TO PLACEMENT OF IMPROVEMENTS. CONTRACTOR IS FULLY RESPONSIBLE FOR CONTACTING APPROPRIATE PARTIES AND ASSURING THAT ALL UTILITIES ARE LOCATED PRIOR TO CONSTRUCTION.
9. COORDINATE HARDSCAPE AND PLANTING INSTALLATION WITH ANY LIGHTING OR IRRIGATION INSTALLATION.
10. CONTRACTOR RESPONSIBLE FOR VERIFYING ALL SPECIFICATIONS AND INSTALLATION REQUIREMENTS OF IRRIGATION, LIGHTING, FENCING, MONUMENTATION, ETC. TO ENSURE THAT PRODUCTS ARE INSTALLED PROPERLY AND PER MANUFACTURER'S REQUIREMENTS PER LOCAL AGENCY CODES & REGULATIONS.
11. ESP ASSOCIATES, INC. IS NOT RESPONSIBLE FOR OBTAINING BUILDING PERMITS.
12. ESP ASSOCIATES, INC. IS NOT RESPONSIBLE FOR INSTALLATION OF LIGHTING, LANDSCAPING, FENCING, IRRIGATION, OR MONUMENT CONSTRUCTION. THE INSTALLATION REQUIREMENTS AND DESIGN IS THE RESPONSIBILITY OF THE CONTRACTOR.
13. IN THE EVENT OF A SEPARATION OF RESPONSIBILITIES BETWEEN TWO CONTRACTORS, LANDSCAPE CONTRACTOR IS REQUIRED TO COORDINATE WORK WITH THE GENERAL CONTRACTOR.
14. THE CONTRACTOR IS RESPONSIBLE FOR ENSURING THAT ALL NECESSARY PERMITS AND APPROVALS HAVE BEEN OBTAINED PRIOR TO CONSTRUCTION. THESE PERMITS AND APPROVALS MAY INCLUDE BUT ARE NOT LIMITED TO GRADING, DEMOLITION, ZONING, BUILDING, DRIVEWAY, DETENTION, SEWER AND WATER OR ANY OTHERS NOT SPECIFICALLY LISTED.
15. THE CONTRACTOR SHALL COMPLY WITH ALL RULES AND REGULATIONS OF FEDERAL, STATE, COUNTY, AND LOCAL MUNICIPALITIES. ALL CONSTRUCTION SHALL CONFORM OR EXCEED REGULATIONS OF WAKE COUNTY, THE STATE OF NORTH CAROLINA, THE AMERICANS WITH DISABILITIES ACT, AND OTHER APPLICABLE STANDARDS AND GOVERNING AUTHORITIES.
16. EXISTING UTILITIES SHOWN ARE FOR THE CONTRACTOR'S CONVENIENCE ONLY AND ARE BASED ON PLANS BY THE NAU COMPANY.
17. THERE MAY BE OTHER UTILITIES NOT SHOWN ON THIS PLAN. THE LANDSCAPE ARCHITECT ASSUMES NO RESPONSIBILITY FOR THE LOCATIONS SHOWN. THE CONTRACTOR IS RESPONSIBLE FOR LOCATING ALL EXISTING UTILITIES PRIOR TO COMMENCEMENT OF CONSTRUCTION. CONFLICTS BETWEEN EXISTING UTILITIES AND PROPOSED IMPROVEMENTS SHALL BE REPORTED TO THE OWNER AND LANDSCAPE ARCHITECT OF RECORD IMMEDIATELY.
18. ESP ASSOCIATES IS NOT RESPONSIBLE FOR LACK OF COORDINATION BETWEEN TRADES RESULTING IN THE NEED TO DEMO EXISTING PAVEMENTS & STRUCTURES OR MOVE EXISTING UTILITIES IN ORDER TO BUILD IMPROVEMENTS SHOWN ON THESE PLANS. NOTIFY OWNER AND LANDSCAPE ARCHITECT OF DISCREPANCIES AND CONFLICTS BEFORE WORK BEGINS.

**CONSTRUCTION PRACTICES NOTES:**

1. IF INTERRUPTION OF EXISTING UTILITY SERVICES IS UNAVOIDABLE, CONTRACTOR SHALL PROVIDE MINIMUM OF 48 HOUR NOTICE TO OWNER OR REPRESENTATIVE PRIOR TO INTERRUPTION OF ANY EXISTING UTILITY SERVICE.
2. THE CONTRACTOR IS RESPONSIBLE FOR REPAIR AND/OR REPLACEMENT OF ANY UTILITIES DAMAGED DURING CONSTRUCTION AT HIS/HER OWN EXPENSE. CONTRACTOR IS TO MAINTAIN UTILITY SERVICES INCLUDING: WATER, SANITARY SEWER, STORM SEWER, NATURAL GAS, ELECTRIC AND TELEPHONE AT ALL TIMES DURING CONSTRUCTION.
3. CONTRACTOR SHALL KEEP ALL PARKING AREAS, ALLEYS, DRIVEWAYS, STREETS, ETC. ADJACENT TO THE CONSTRUCTION SITE CLEAN AT ALL TIMES DURING CONSTRUCTION. CONTRACTOR SHALL ENSURE WORK AREA IS CLEAN AND CLEAR OF ALL DEBRIS AND CONSTRUCTION WASTE AT CLOSE OF EACH BUSINESS DAY. NO TOOLS OR EQUIPMENT ARE TO BE LEFT OVERNIGHT WITHOUT EXPRESS PERMISSION OF OWNER. OWNER TAKES NO RESPONSIBILITY FOR LOSS OR DAMAGE TO CONTRACTOR PROPERTY.
4. CONTRACTOR MUST TAKE STEPS TO PREVENT DAMAGE TO EXISTING PAVEMENT OR EXCESSIVE TRACKING OF SOIL, INCLUDING BUT NOT LIMITED TO LAYING ANTI-TRACKING MEASURES DOWN ON ALL ACTIVE DRIVES AND WORK AREAS. ANY EXCESS SOIL OR DEBRIS SPILLAGE MUST BE CLEANED SAME BUSINESS DAY. CONTRACTOR RESPONSIBLE FOR REPAIRING AND REPAIRING ANY EXISTING PAVEMENT AREAS DAMAGED DURING CONSTRUCTION ACTIVITY AT CONTRACTOR'S OWN EXPENSE.
5. SIGNING OF THE CONSTRUCTION AREA SHALL COMPLY WITH THE CURRENT "FHWA MANUAL ON UNIFORM TRAFFIC CONTROL DEVICES" - ALL SIGNAGE INCLUDING REGULATORY AND WARNING SIGNS WHICH ARE OWNED AND MAINTAINED BY THE NCDOT ARE TO REMAIN THROUGHOUT THE DEMOLITION AND CONSTRUCTION PHASES. ALL SIGNS WHICH NEED TO BE REMOVED ARE TO BE RELOCATED IMMEDIATELY.
6. REFER TO COMMUNITY CONSTRUCTION DOCUMENTS FOR COMMUNITY STORMWATER & EROSION CONTROL MEASURES, PLANS, AND PERMITS (BY OTHERS).

**SAFETY AND ACCESS NOTES:**

1. THE CONTRACTOR IS REQUIRED TO MEET ALL APPLICABLE FEDERAL, OSHA, STATE AND LOCAL REGULATIONS CONCERNING PROJECT SAFETY AND ASSUMES RESPONSIBILITY FOR SAFETY ON THE PROJECT.
2. CONTRACTOR SHALL TAKE EVERY PRECAUTION TO PROTECT THE GENERAL PUBLIC FROM CONSTRUCTION AREAS FOR THE DURATION OF THE PROJECT, INCLUDING BUT NOT LIMITED TO NON-WORKING HOURS.
3. NECESSARY BARRICADES, SUFFICIENT LIGHTS, SIGNS, AND OTHER TRAFFIC CONTROL METHODS AS MAY BE NECESSARY FOR THE PROTECTION AND SAFETY OF THE PUBLIC SHALL BE PROVIDED AND MAINTAINED THROUGHOUT THE LIFE OF THE PROJECT. CONTRACTOR IS RESPONSIBLE FOR PLACING BARRICADES, USING FLAG MEN, ETC. AS NECESSARY TO ENSURE PUBLIC SAFETY.
4. CONTRACTOR ACCESS FOR CONSTRUCTION DIRECTED BY OWNERS REPRESENTATIVE.
5. CONTRACTOR SHALL PREPARE A CONSTRUCTION SCHEDULE AND VEHICULAR ACCESS SCHEDULE AND COORDINATE WITH NCDOT AND OWNER FOR TRAFFIC IMPACTS.

**LAYOUT NOTES:**

1. CONTRACTOR RESPONSIBLE FOR LOCATING ALL SIGHT TRIANGLES AND SIGHT DISTANCE LINES PRIOR TO INSTALLATION IF PROPOSED IMPROVEMENTS ARE WITHIN SIGHT DISTANCE OR SIGHT TRIANGLES CONTRACTOR SHALL NOTIFY OWNER AND NOT PROCEED WITH PROPOSED IMPROVEMENTS.
2. LOCATION OF UTILITIES REPRESENTED ON THESE PLANS HAVE BEEN PROVIDED FOR INFORMATION PURPOSES. CONTRACTOR IS RESPONSIBLE FOR LOCATING UTILITIES (BOTH PUBLIC & PRIVATE) PRIOR TO START OF WORK ON THIS SITE. CONTACT THE LANDSCAPE ARCHITECT IMMEDIATELY IF SITE CONDITIONS CHANGE.
3. CONTRACTOR SHALL STAKE ALL WORK (INCLUDING MONUMENT LOCATIONS, FENCE LOCATIONS, PLANT LOCATIONS, AND SIDEWALK LOCATIONS) AND OBTAIN APPROVAL FROM OWNER PRIOR TO CONSTRUCTION. ANY DISCREPANCIES SHALL BE RESOLVED PRIOR TO CONSTRUCTION.
4. CONTRACTOR SHALL INSTALL ALL STRUCTURES (INCLUDING ASSOCIATED FOOTERS) AND PLANTINGS OUTSIDE OF SIGHT TRIANGLES, SIGHT DISTANCE LINES, AND UTILITY EASEMENTS.
5. FOOTER LOCATIONS HAVE BEEN DIMENSIONED TO THE CENTER OF THE FOOTER.
6. CONTRACTOR TO PROTECT AND PRESERVE EXISTING VEGETATION TO THE GREATEST EXTENT POSSIBLE. COORDINATE WITH OWNER & APPROPRIATE AGENCIES PRIOR TO REMOVAL OF EXISTING TREES/VEGETATION.
7. CONTRACTOR SHALL NOT PERFORM ANY WORK OFFSITE. IF EXTENUATING CIRCUMSTANCES REQUIRE WORK TO BE PERFORMED OFFSITE CONTRACTOR SHALL SUBMIT WRITTEN NOTICE TO OWNERS REPRESENTATIVE AS SOON AS POSSIBLE. CONTRACTOR SHALL NOT PROCEED WITH WORK OFFSITE UNTIL WRITTEN APPROVAL IS OBTAINED FROM OWNER OR OWNER'S REPRESENTATIVE. ANY AREAS DISTURBED SHALL BE RETURNED TO A CONDITION EQUAL TO OR BETTER THAN THE EXISTING CONDITION.

**SITE PREPARATION/GRADING:**

1. GRADING AND SITE PREPARATION IS THE RESPONSIBILITY OF THE OWNER/CONTRACTOR.
2. ALL DEBRIS FROM DEMOLITION OPERATIONS SHALL BE DISPOSED OF OFF-SITE IN ACCORDANCE WITH LOCAL, STATE, AND FEDERAL REGULATIONS.

**HARDSCAPE INSTALLATION NOTES:**

1. PLAN AND DETAILS SHOWN FOR DIMENSIONAL AND MATERIAL PURPOSES ONLY.
2. ALL DETAILED STRUCTURAL, REINFORCEMENT, ELECTRICAL DESIGN, AND HARDWARE BY OTHERS.
3. CONTRACTOR SHALL PROVIDE SAMPLES OF ALL MATERIALS, FINISHES, INCLUDING STONE VENEER, SIGN FACE, GROUT, MORTAR, LIGHTS, DECORATIVE HARDWARE, SOIL MIX, ETC., AND OBTAIN APPROVAL FROM OWNER AND LANDSCAPE ARCHITECT PRIOR TO CONSTRUCTION OR CONTRACTOR SHALL CREATE A MOCK-UP OF WALL, CAP, AND TRIM WITH DECORATIVE HARDWARE AND OBTAIN APPROVAL FROM OWNER OR LANDSCAPE ARCHITECT PRIOR TO FABRICATION AND INSTALLATION.

**LIGHTING STANDARDS:**

1. COORDINATE ALL LIGHTING, CONDUITS AND ELECTRICAL COMPONENTS WITH ELECTRICIAN LICENSED TO DO WORK IN NORTH CAROLINA PRIOR TO INSTALLATION OF FOOTINGS AND OTHER LANDSCAPE IMPROVEMENTS.
2. LIGHTING DESIGN IS TO BE COMPLETE BY OTHERS. LIGHT FIXTURE SHOWN ON SITE PLANS IS FOR DESIGN INTENT ONLY.
3. CONTRACTOR RESPONSIBLE FOR INSTALLING UPLIGHTING. SEE LOW VOLTAGE LIGHTING ON SITE LAYOUT AND PLANTING PLANS FOR APPROXIMATE LOCATION.
4. UPLIGHTING TO BE FX LUMINAIRE LOW-VOLTAGE LED UPLIGHT MODEL PB-3LED-FB WARM 2,700K LAMP OR OWNER APPROVED EQUIVALENT.
5. SIGN SCENCE LIGHTING TO BE POSSINI EURO ACKERLY 14" TEXTURED BLACK OUTDOOR LANTERN WALL LIGHT.
6. LIGHTING TO BE INSTALLED PER MANUFACTURER'S SPECIFICATIONS AND REQUIREMENTS WHICH MAY INCLUDE THE FOLLOWING:
  - LIGHT FIXTURES TO CONTAIN HIGH OUTPUT LED BULBS.
  - LIGHTING SYSTEM TO INCLUDE PHOTOCELL FOR AUTOMATIC DUSK-TO-DAWN OPERATION AND TRANSFORMER.
  - FIXTURE IS BLACK FINISH.
  - FIXTURE TO INCLUDE LIGHT, BASE ASSEMBLY AND GROUND STAKE.
  - WIRING TO BE INSTALLED PER MANUFACTURER'S RECOMMENDATION.
  - LIGHT OUTPUT TO BE 6 WATTS. WATTAGE SUBJECT TO CHANGE PER FINAL DESIGN.
  - PROVIDE APPROVED CONNECTIONS TO EXISTING ELECTRICAL SYSTEM AS IS REQUIRED FOR THE PROPER OPERATION OF THE AUTOMATIC CONTROL SYSTEM.
  - ALL ELECTRICAL WORK SHALL BE INSTALLED IN CONFORMANCE WITH NATIONAL, STATE, AND LOCAL ELECTRICAL CODES.
  - THE ENTIRE SYSTEM SHALL FULLY COMPLY WITH LOCAL, STATE, AND NATIONAL REGULATIONS, ORDINANCES, AND ESTABLISHED LOCAL CODES APPLICABLE HERETO. IT IS THE CONTRACTOR'S RESPONSIBILITY TO ESTABLISH COMPLIANCE.
  - MATERIALS USED IN THE SYSTEM SHALL BE NEW AND WITHOUT FLAWS OR DEFECTS OF ANY TYPE.
  - CONTRACTORS SHALL PROVIDE A CERTIFICATE OF WARRANTY FOR ONE YEAR FROM THE DATE OF FINAL ACCEPTANCE OF THE SYSTEM AND SHALL APPLY FOR ANY WARRANTIES IN THE OWNER'S NAME AND TURN PAPERWORK OVER TO THE OWNER UPON SUBMITTAL.
  - CONTRACTOR RESPONSIBLE FOR OBTAINING ANY AND ALL NECESSARY BUILDING PERMITS RELATED TO THE CONSTRUCTION OF THE MONUMENTS AND THEIR LIGHTING SYSTEMS.
  - CONTRACTOR SHALL OBTAIN ALL NECESSARY PERMITS PRIOR TO CONSTRUCTION AND COMMENCEMENT OF WORK.

**LIGHTING INFORMATION:**

VENDOR: FX LUMINAIRE  
 CONTRACT: LANCE ROSSELL  
 PHONE: 919-214-4818  
 EMAIL: LANCE.ROSSL@HUNTERINDUSTRIES.COM

**GENERAL DETAIL NOTES:**

1. STONE VENEER TO BE APPROVED PER OWNER BEFORE START OF INSTALLATION.
2. ALL CAPS SHALL BE INSTALLED TO PROMOTE POSITIVE DRAINAGE
3. ALL SIGN LOCATIONS TO BE STAKED AND REVIEWED BY OWNER AND CONTRACTOR TO CONFIRM PROPER VERTICAL MONUMENT / SIGN PANEL LOCATION PRIOR TO CONSTRUCTION.
4. SAMPLES OF ALL MATERIALS SHALL BE SUBMITTED TO OWNER FOR APPROVAL.



**FOR AGENCY REVIEW ONLY**

NO.	DATE	REVISION

**SITE LAYOUT PLAN**  
**MASON RIDGE - ENTRANCE MONUMENT**  
**CONSTRUCTION DOCUMENTS**  
 HARNETT COUNTY, NC  
 D.R. HORTON

PROJECT INFORMATION	
PROJECT MANAGER:	MS
DESIGNED BY:	MS
DRAWN BY:	BA
PROJECT NUMBER:	24-01007
ORIGINAL DATE:	09/10/2024

**H1.0**

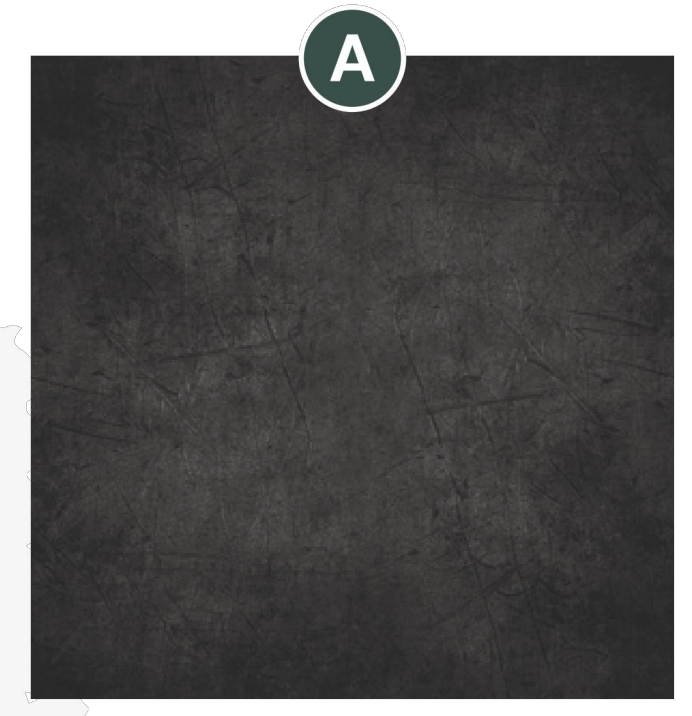

**Sign Panel**  
Corrosion-Resistant Sign Panel, Aluminum; Matte Black

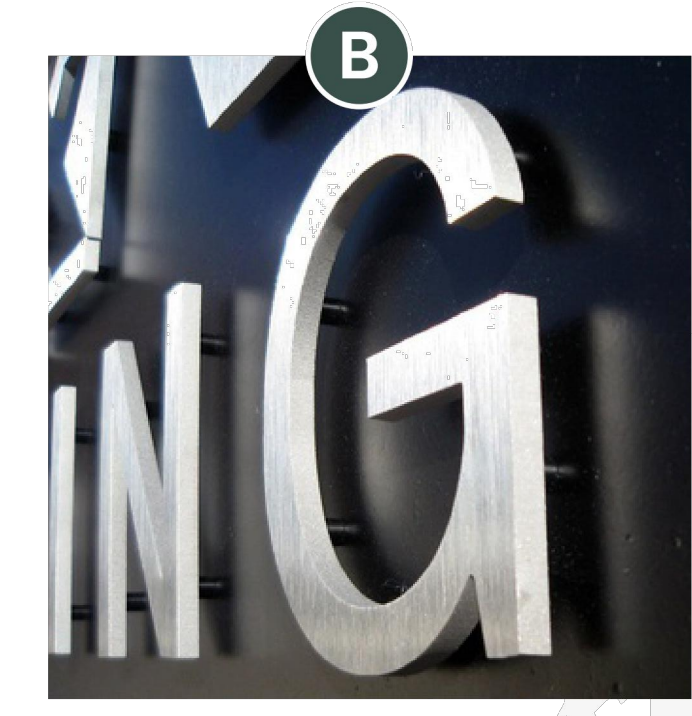

**Sign Letters**  
Caset/Acrylic Channel Letters  
Pure White

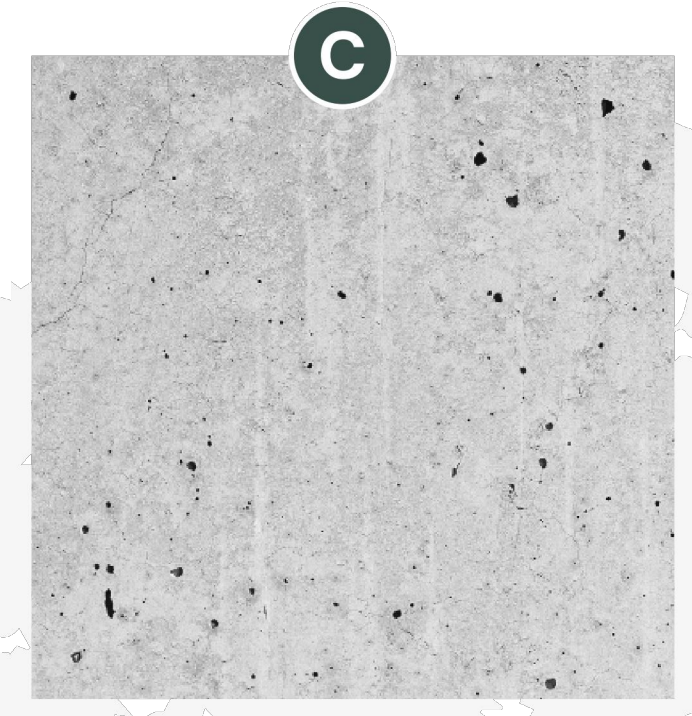

**Sign Base Cap**  
Concrete Base Cap; Keystone  
Cool Grey Tones

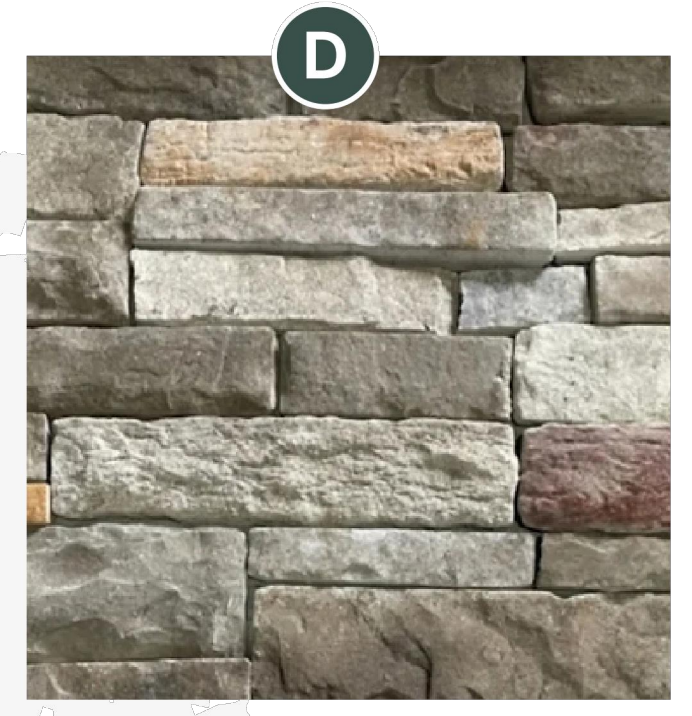

**Masonry Sign Base**  
Mucina Stone  
Saranda Ledgestone

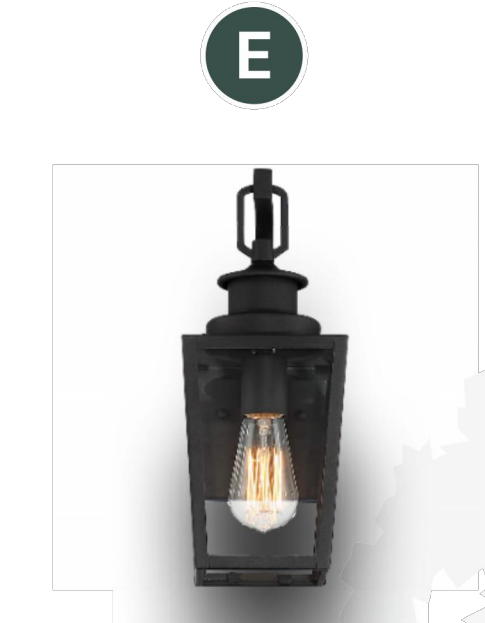

**Column Sconce**  
Possini Euro 14" Lantern  
Finish: Black

**Decorative Wall & Columns**  
5.25' H x 16.55' L  
87 sf

+ elements are freestanding and separate from sign structure. To be included as landscape element within buffer (per Harnett County UDO 9.3.1B).

**Entrance Monument Sign**  
6' H x 8.33' L  
50 sf



**FRONT ELEVATION**

SCALE: NTS

SEE DETAIL SHEET H2.1 & H2.2 FOR ADDITIONAL DIMENSIONS

S:\RP\1024\Projects\24-01007\Monuments\Sheets\24-01007\MON-DET.dwg, 10.0 ENTRANCE MONUMENT CONCEPTUAL ELEVATION.dwg

ESP Associates, Inc.  
2200 Gateway Centre Blvd  
Suite 216  
Merrillville, NC 27660  
919-678-1070  
www.espsociates.com  
NC LICENSE #F-1407

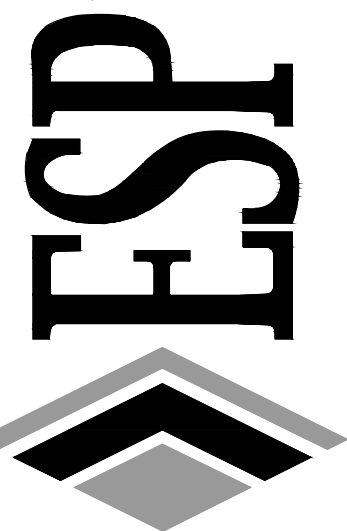

FOR AGENCY  
REVIEW ONLY

NO.	DATE	REVISION	BY

**ENTRANCE MONUMENT**  
**CONCEPTUAL ELEVATION**  
**MASON RIDGE - ENTRANCE MONUMENT**  
**CONSTRUCTION DOCUMENTS**  
D.R. HORTON  
HARNETT COUNTY, NC

PROJECT INFORMATION	
PROJECT MANAGER:	MS
DESIGNED BY:	MS
DRAWN BY:	BA
PROJECT NUMBER:	24-01007
ORIGINAL DATE:	09/10/2024
SHEET:	H2.0

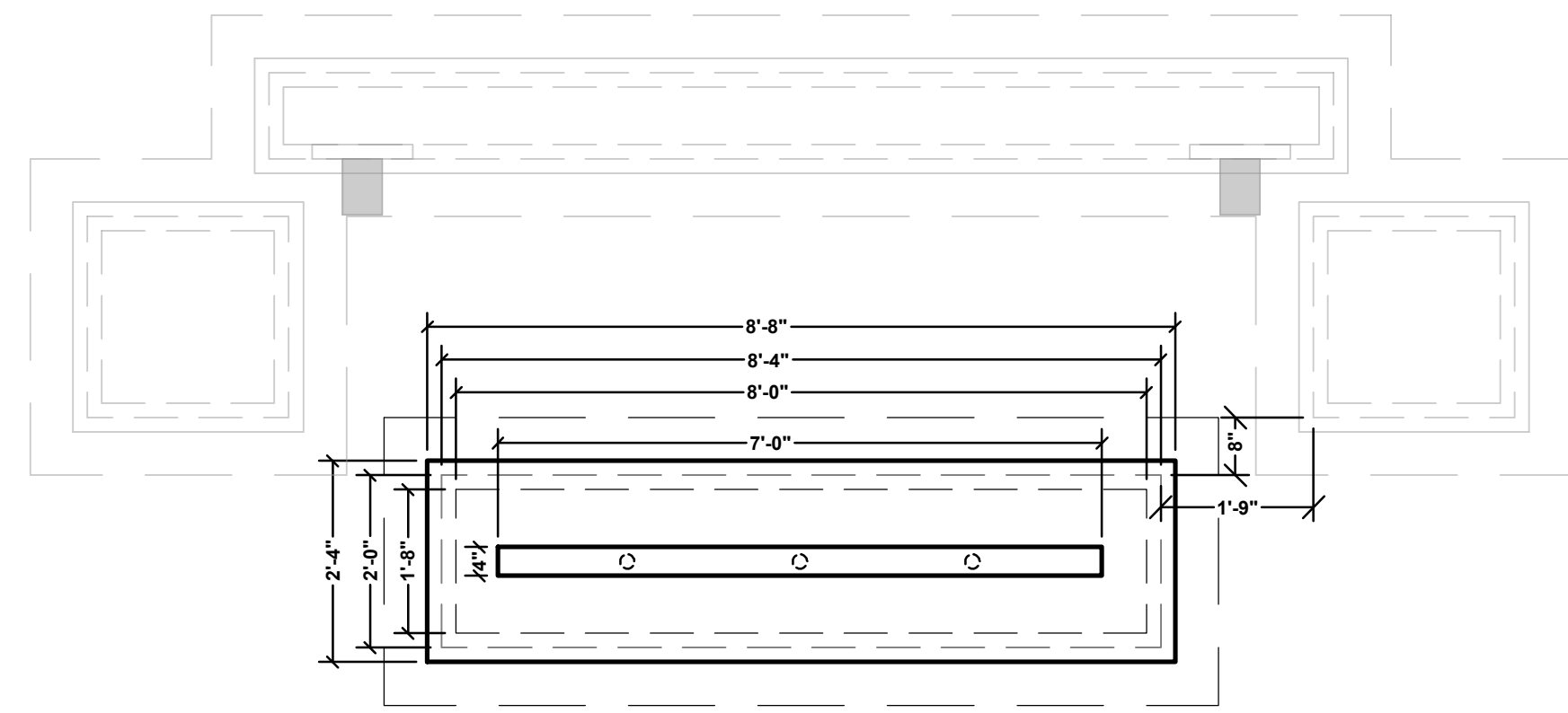

**1** DIMENSIONAL LAYOUT  
SCALE: 1/2" = 1'

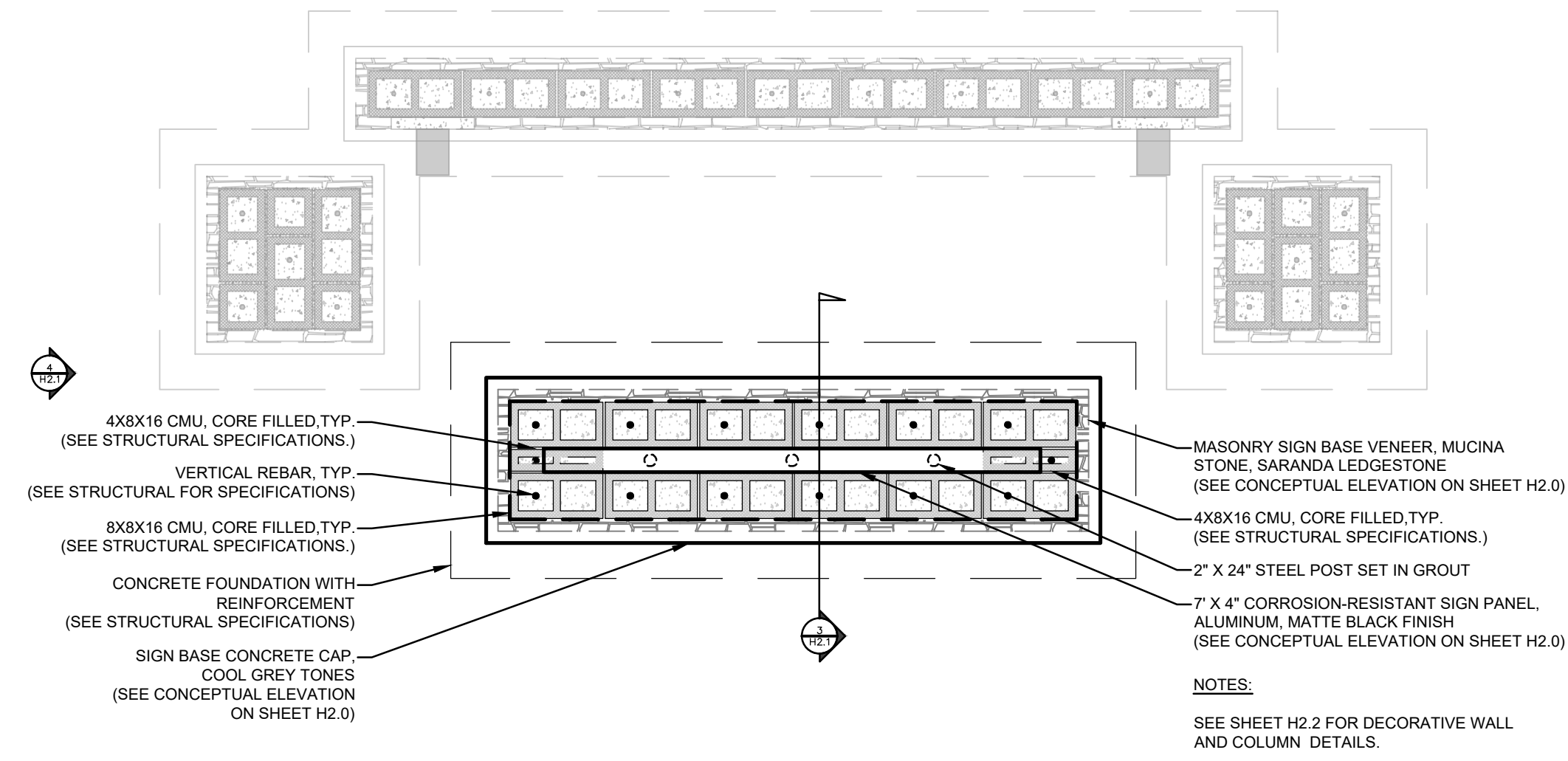

**2** SIGN PLAN  
SCALE: 1/2" = 1'

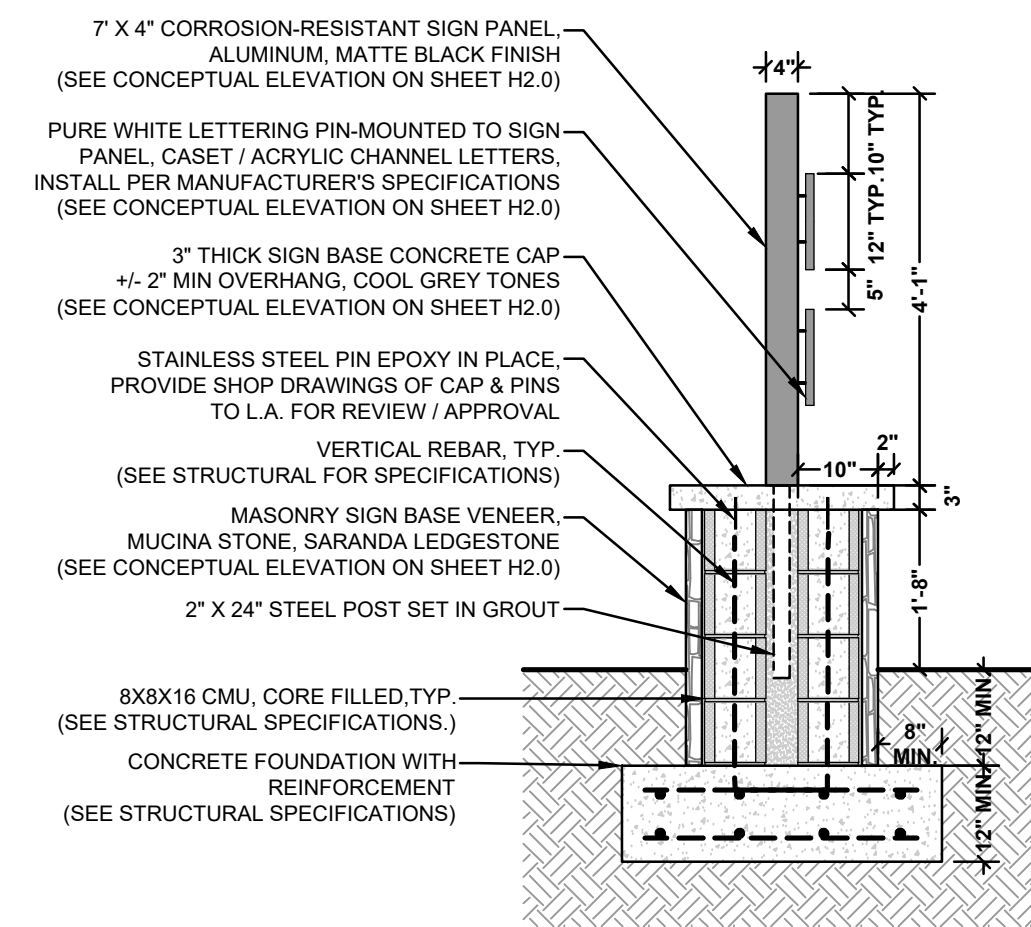

**3** MONUMENT SIGN SECTION  
SCALE: 1/2" = 1'

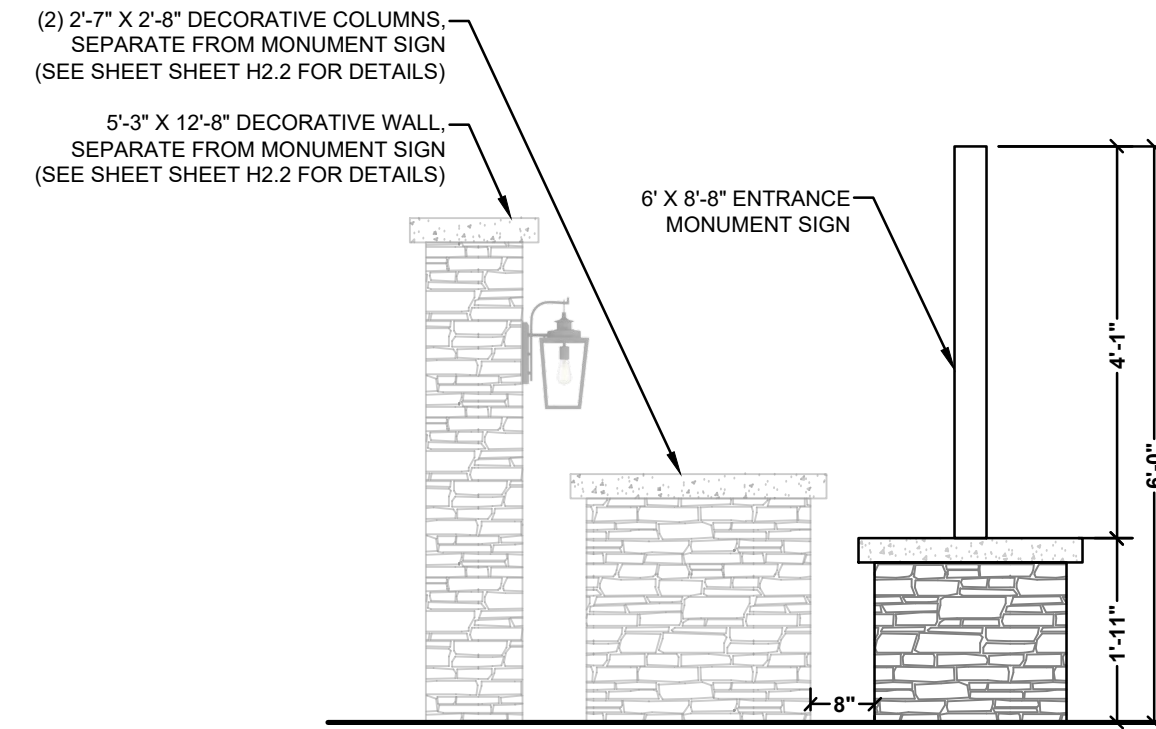

**4** MONUMENT SIGN ELEVATION  
SCALE: 1/2" = 1'

NO.	DATE	REVISION	BY

**ENTRANCE MONUMENT DETAILS**  
**MASON RIDGE - ENTRANCE MONUMENT**  
**CONSTRUCTION DOCUMENTS**  
HARNETT COUNTY, NC  
D.R. HORTON

PROJECT INFORMATION	
PROJECT MANAGER:	MS
DESIGNED BY:	MS
DRAWN BY:	BA
PROJECT NUMBER:	24-01007
ORIGINAL DATE:	09/10/2024

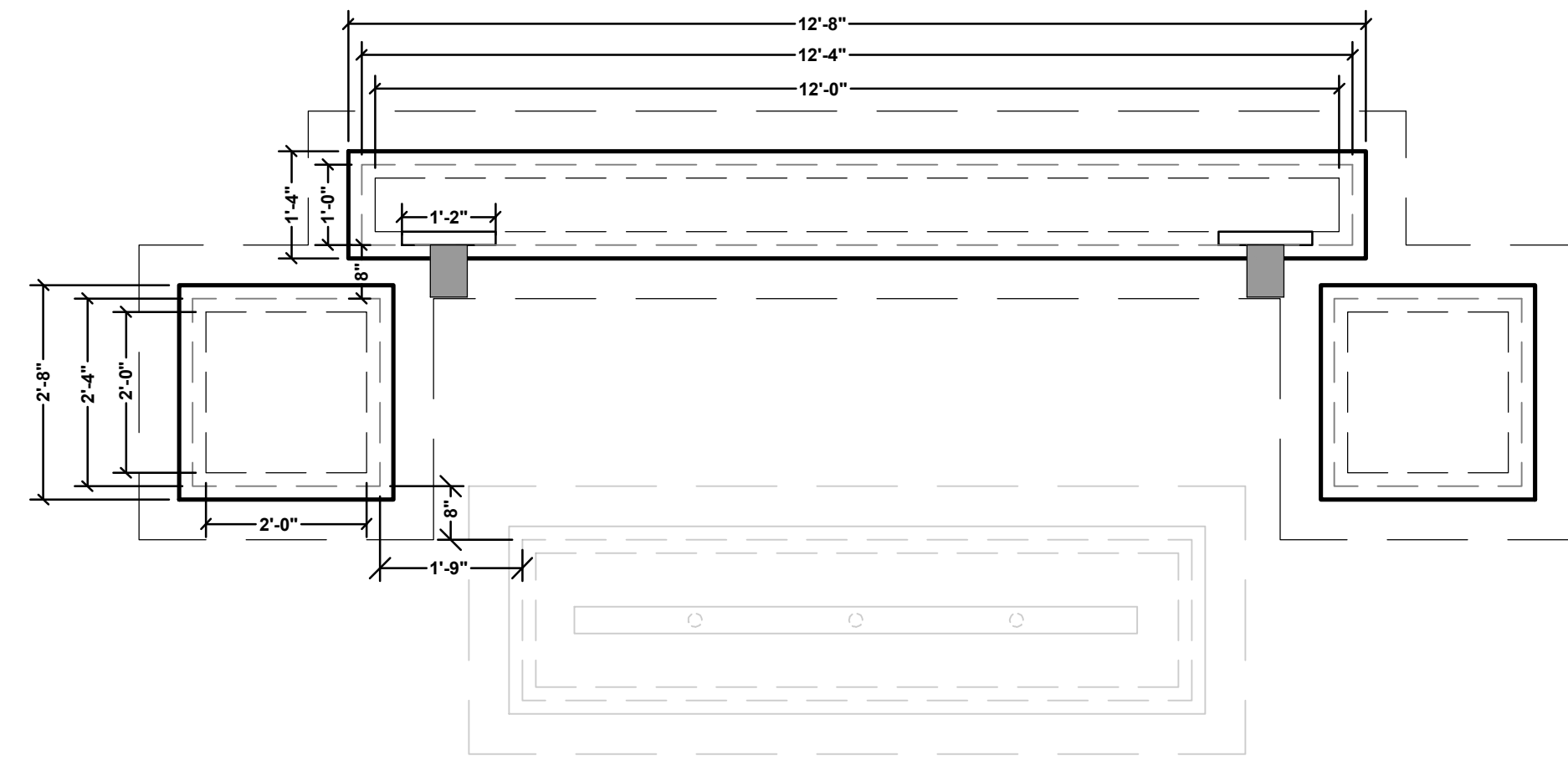

**1** DIMENSIONAL LAYOUT  
SCALE: 1/2" = 1'

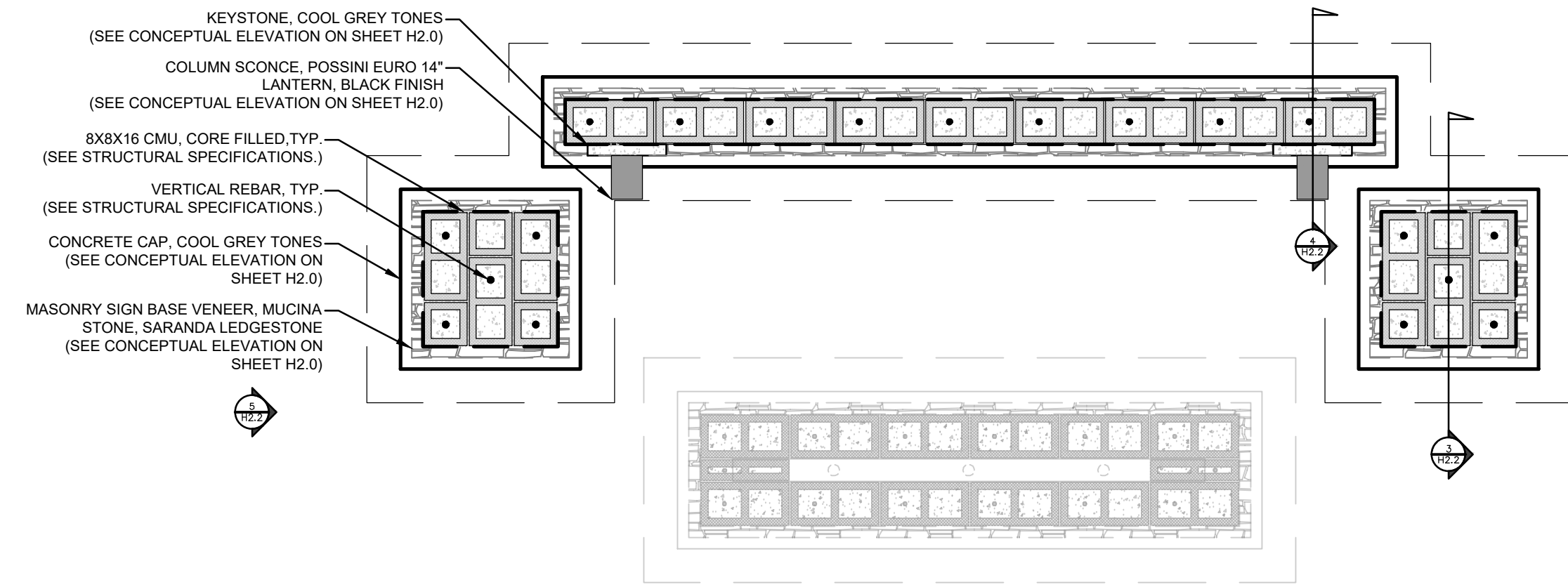

NOTES:  
SEE SHEET H2.1 FOR ENTRANCE MONUMENT SIGN DETAILS.

**2** WALL / COLUMN PLAN  
SCALE: 1/2" = 1'

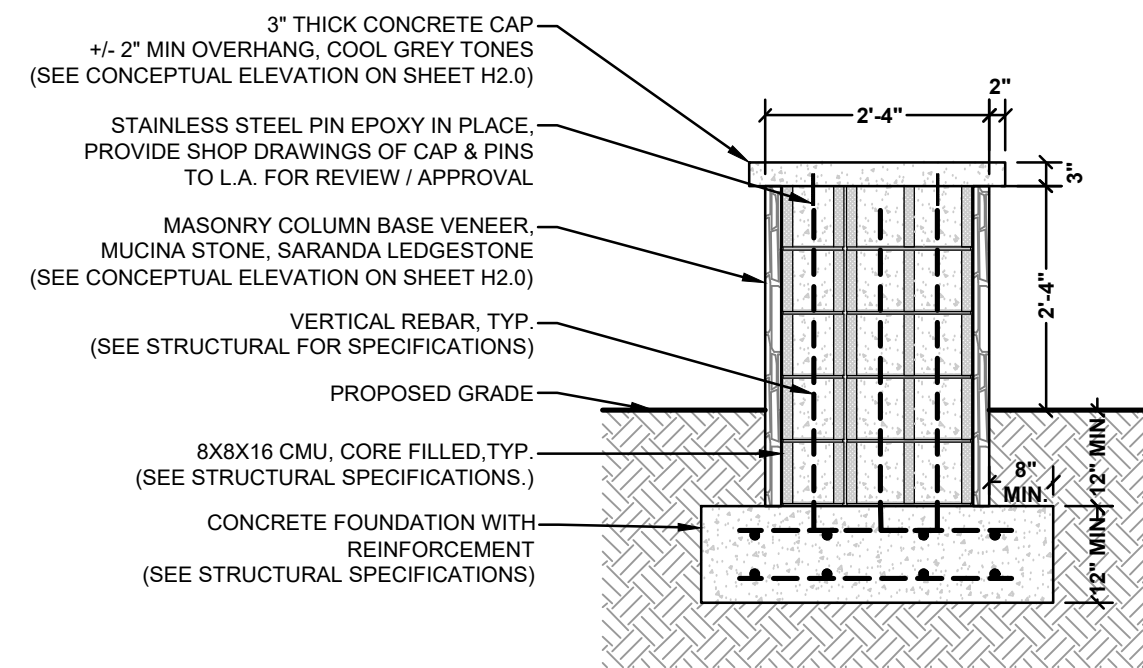

**3** COLUMN : SECTION  
SCALE: 1/2" = 1'

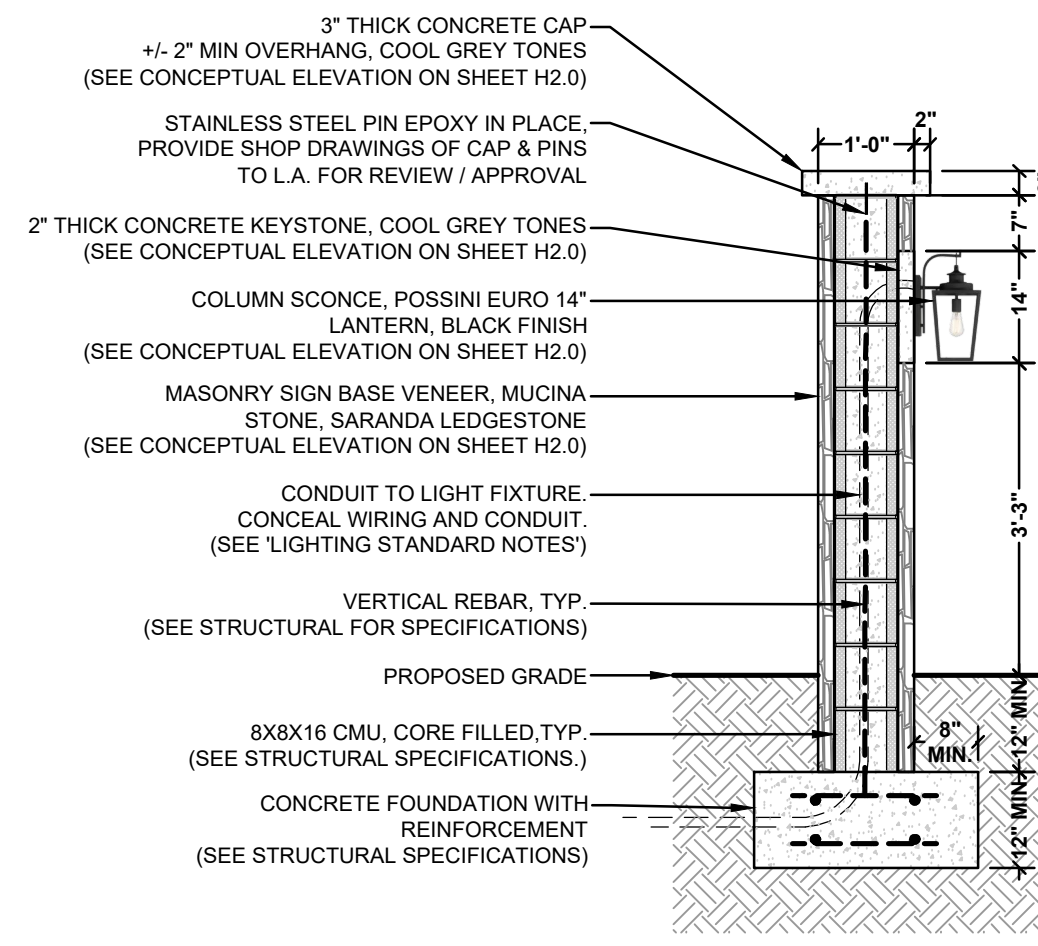

**4** WALL : SECTION  
SCALE: 1/2" = 1'

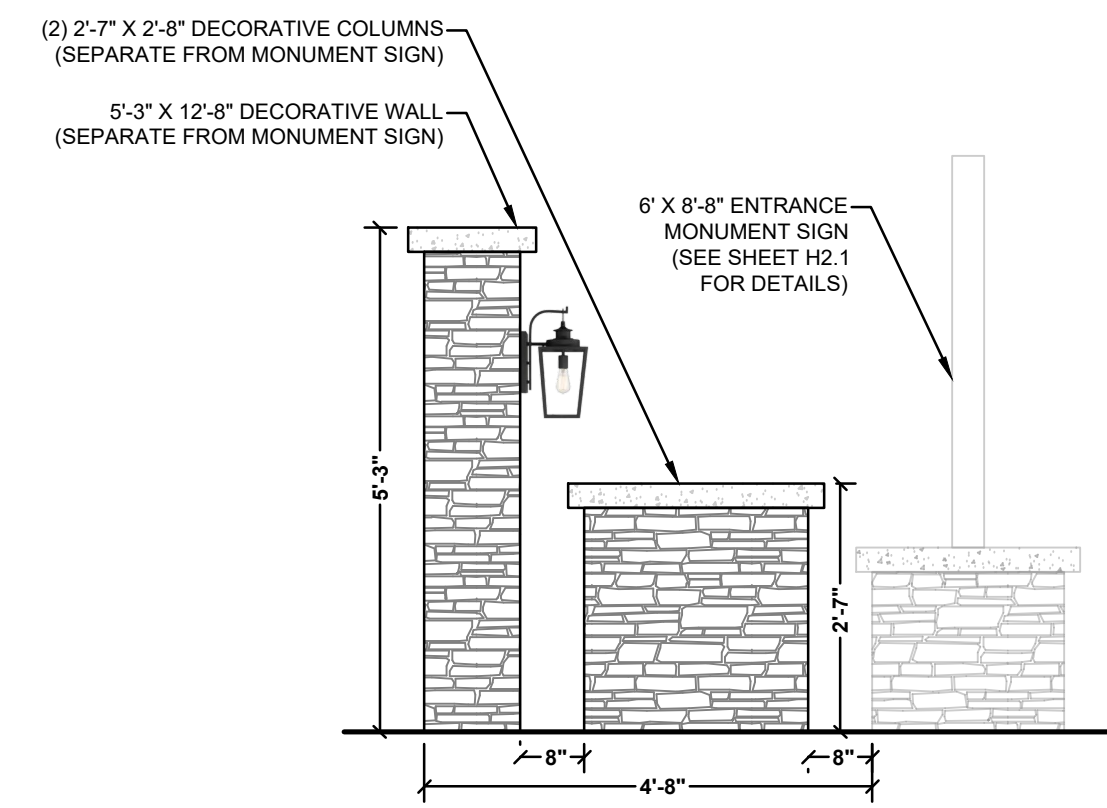

**5** WALL / COLUMN ELEVATION  
SCALE: 1/2" = 1'

S:\RP\1024\Projects\24-01007\Monuments\Sheets\24-01007.MON\_DET.dwg, H2.2 DECORATIVE MASONRY DETAILS.rvt

ESP Associates, Inc.  
2300 Gateway Centre Blvd  
Suite 216  
Merrville, NC 27660  
919-678-1070  
www.espsociates.com  
NC LICENSE #F-1407



FOR AGENCY  
REVIEW ONLY

NO.	DATE	REVISION	BY

**DECORATIVE MASONRY DETAILS**  
**MASON RIDGE - ENTRANCE MONUMENT**  
**CONSTRUCTION DOCUMENTS**  
 HARNETT COUNTY, NC  
 D.R. HORTON

PROJECT INFORMATION	
PROJECT MANAGER:	MS
DESIGNED BY:	MS
DRAWN BY:	BA
PROJECT NUMBER:	24-01007
ORIGINAL DATE:	09/10/2024
SHEET:	<b>H2.2</b>

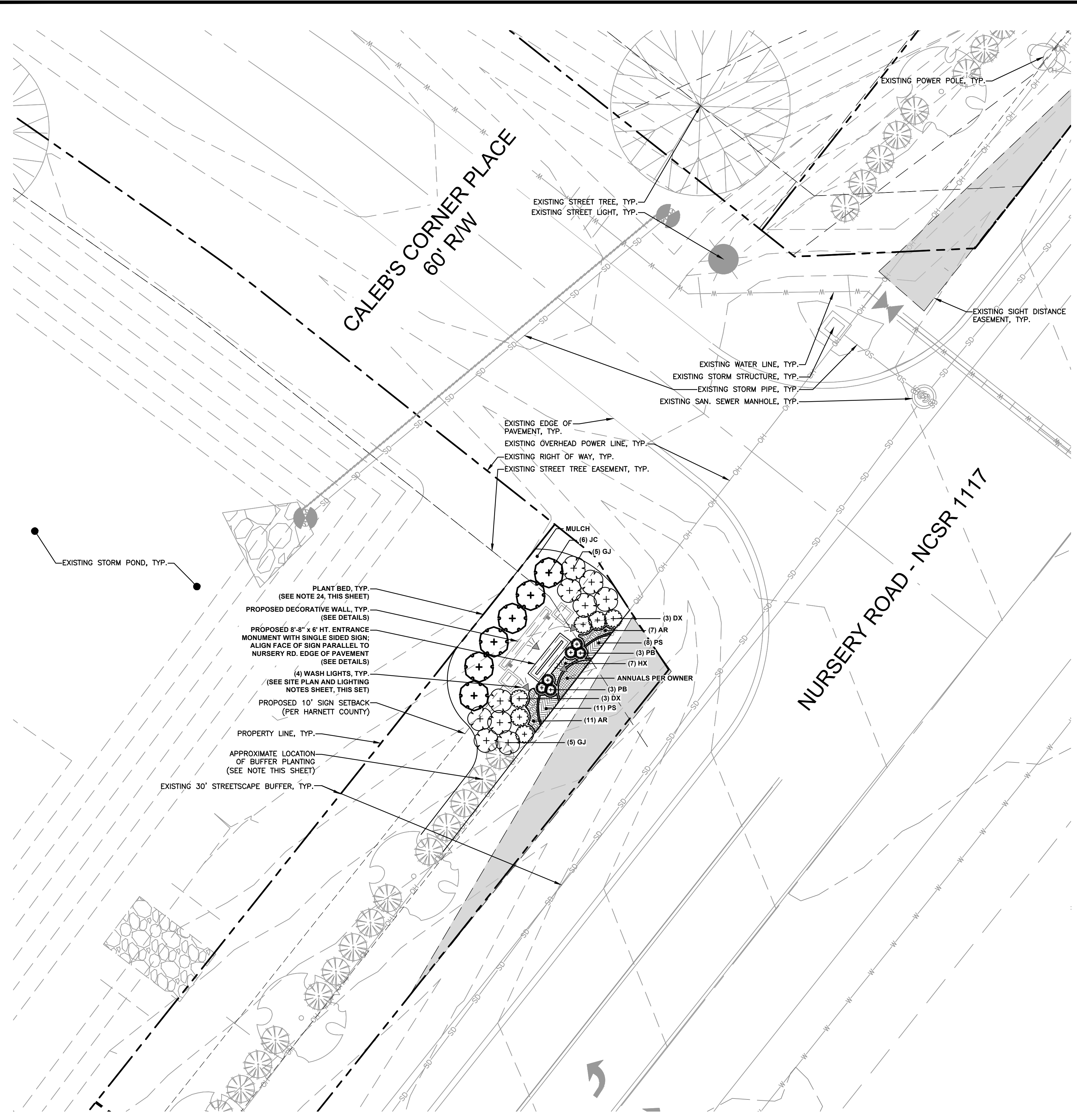

**PLANTING NOTES:**

**GENERAL NOTES:**

- ALL MATERIALS AND METHODS OF CONSTRUCTION SHALL BE IN ACCORDANCE WITH THE HARNETT COUNTY AND THE STATE OF NORTH CAROLINA STANDARDS AND SPECIFICATIONS.
- ALL LANDSCAPE WORK SHALL BE PROVIDED BY OR UNDER THE SUPERVISION OF A LICENSED NC LANDSCAPE CONTRACTOR.
- LOCATIONS OF EXISTING UTILITY LINES SHOWN ON PLANS ARE BASED UPON BEST AVAILABLE INFORMATION AND CONSIDERED APPROXIMATE. THE CONTRACTOR SHALL BE RESPONSIBLE FOR LOCATING ALL UNDERGROUND UTILITIES IN AND ADJACENT TO THE WORK AREAS PRIOR TO THE BEGINNING OF WORK. ALL UTILITY LINES SHALL BE PROTECTED DURING THE CONSTRUCTION TO AVOID DAMAGE. HAND EXCAVATE, AS REQUIRED, THE CONTRACTOR SHALL BE RESPONSIBLE FOR REPAIRING ANY AND ALL UTILITIES, STRUCTURES, SITE APPURTENANCES, ETC. DAMAGED DURING CONSTRUCTION OR INSTALLATION OF PLANT MATERIAL AT CONTRACTOR'S EXPENSE.
- THE LOCATION OF ALL EXISTING UTILITIES SHALL BE CONFIRMED PRIOR TO BEGINNING CONSTRUCTION. CALL "NC ONE-CALL", 1-800-632-4949. THE OWNER SHALL BE NOTIFIED OF ANY DISCREPANCIES BETWEEN FIELD CONDITIONS AND THOSE SHOWN ON THE PLAN.
- ALL DIMENSIONS AND ELEVATIONS SHALL BE VERIFIED IN THE FIELD PRIOR TO CONSTRUCTION. ANY DISCREPANCIES SHALL BE BROUGHT TO THE ATTENTION OF THE LANDSCAPE ARCHITECT.
- THE LANDSCAPE CONTRACTOR SHALL FURNISH AND INSTALL ALL PLANT MATERIALS, LABOR AND OTHER MATERIALS NECESSARY TO COMPLETE THE WORK AS SHOWN ON THE PLANS AND DETAILS.
- THE CONTRACTOR SHALL BE RESPONSIBLE FOR VERIFYING ALL QUANTITIES SHOWN IN THE PLANT SCHEDULE AND MATCH QUANTITIES ON THE PLANS PRIOR TO PRICING WORK. SHOULD DISCREPANCIES OCCUR, THE LANDSCAPE ARCHITECT SHALL BE NOTIFIED PRIOR TO BIDDING.
- ALL PLANT MATERIAL SHALL MEET MINIMUM SIZE STANDARDS, INCLUDING THE MINIMUM HEIGHT, WIDTH, ROOT BALL SIZE AND NUMBER OF BRANCHES, SET FORTH IN THE LATEST EDITION OF THE "AMERICAN STANDARD FOR NURSERY STOCK" PUBLISHED BY THE AMERICAN ASSOCIATION OF NURSERYMEN (AAN) FOR THE TYPE OF TREE OR SHRUB AT THE TIME OF INSTALLATION.
- ALL PLANTS SHALL BE NURSERY GROWN UNDER THE SAME CLIMATE CONDITIONS AS THE LOCATION OF THE PROJECT FOR AT LEAST TWO YEARS BEFORE PLANTING. ALL PLANTS SHALL BE IN ACCORDANCE WITH GOOD HORTICULTURAL PRACTICES, HEALTHY, VIGOROUS, AND FREE OF INSECTS, EGGS, LARVAE, DISEASES AND DEFECTS SUCH AS KNOTS, SUN-SCALD, INJURIES, ABRASIONS OR DISFIGUREMENT. PLANT MATERIAL COLLECTED FROM NATURALIZED AREAS SHALL BE REJECTED.
- SUBSTITUTIONS IN PLANT SPECIES OR SIZE SHALL NOT BE PERMITTED EXCEPT WITH THE WRITTEN APPROVAL OF THE LANDSCAPE ARCHITECT.
- CALIPER, HEIGHT AND WIDTH SPECIFICATIONS INDICATED ON THE PLANT SCHEDULE SHALL TAKE PRECEDENCE OVER CONTAINER SIZE.
- PLANT SIZES SHOWN IN THE PLANT SCHEDULE ARE THE MINIMUM SIZES BEFORE PRUNING. ANY NECESSARY PRUNING APPROVED BY LANDSCAPE ARCHITECT SHALL BE PERFORMED AT THE TIME OF PLANTING IF NEEDED. TREES AND SHRUBS OF LARGER SIZE MAY BE INSTALLED IF SIZES OF THE ROOTS OR BALLS ARE INCREASED PROPORTIONATELY.
- THE CONTRACTOR IS RESPONSIBLE FOR INSTALLING PLANTS TO MEET THE MINIMUM SIZE AND SPACING FOR CODE COMPLIANCE. FAILURE TO INSTALL THE PLANT MATERIAL PER THE PLAN AND PLANT SCHEDULE MAY JEOPARDIZE ISSUANCE OF FINAL CERTIFICATE OF OCCUPANCY. CONTRACTOR SHALL BE RESPONSIBLE FOR SCHEDULING INSPECTIONS OF PLANT MATERIAL.
- ALL SHADE/CANOPY STREET TREES SHALL BE GRADE 'A' SPECIMENS WITH A STRAIGHT MAIN LEADER AND FULL HEAD.
- ALL TREES OF THE SAME VARIETY SHALL MATCH IN SHAPE AND SIZE WHEN INSTALLED AS GROUPS, ROWS OR STREET TREES.
- ALL PLANTS SHALL BE BALLED AND BURLAPPED OR CONTAINER GROWN AS INDICATED IN THE PLANT SCHEDULE.
- ALL PLANTS SHALL BE SUBJECT TO THE APPROVAL OF THE LANDSCAPE ARCHITECT BEFORE, DURING AND AFTER INSTALLATION FOR COMPLIANCE WITH REQUIREMENTS FOR NAME, VARIETY, SIZE, QUALITY AND INSTALLATION.
- AREAS DAMAGED BY ACTIVITIES OF THE LANDSCAPE CONTRACTOR SHALL BE RESEDED/REPLANTED AND REPAIRED AT NO ADDITIONAL COST TO THE OWNER.
- CONTRACTOR SHALL PROVIDE TREES PROTECTION FENCING PER THE PLANS AND TREE PROTECTION FENCE DETAIL TO PROTECT ANY EXISTING TREES, SHRUBBERY AND PLANTING BEDS IN THE PLANTING AREA.
- CONTRACTOR SHALL OBTAIN AUTHORIZATION PRIOR TO ANY CHANGES OF FIELD LOCATIONS DUE TO UTILITIES OR OTHER CONFLICTS.
- ALL STRUCTURES, WALLS, PIERS AND PLANT BED LOCATIONS SHALL BE FIELD STAKED BY THE CONTRACTOR AND LOCATION APPROVED BY THE OWNER PRIOR TO CONSTRUCTION/INSTALLATION.
- NO WORK SHALL BE PERFORMED IN THE PUBLIC RIGHT-OF-WAY UNLESS ALL REQUIRED PERMITS ARE OBTAINED.
- ALL EQUIPMENT AND TOOLS SHALL BE PLACED SO AS NOT TO INTERFERE OR HINDER PEDESTRIAN OR VEHICULAR TRAFFIC FLOW.
- CONTRACTOR TO FIELD VERIFY BUFFER PLANTING PRIOR TO PLANTING INSTALLATION. ANY DISCREPANCIES SHALL BE BROUGHT TO THE ATTENTION OF THE LANDSCAPE ARCHITECT.

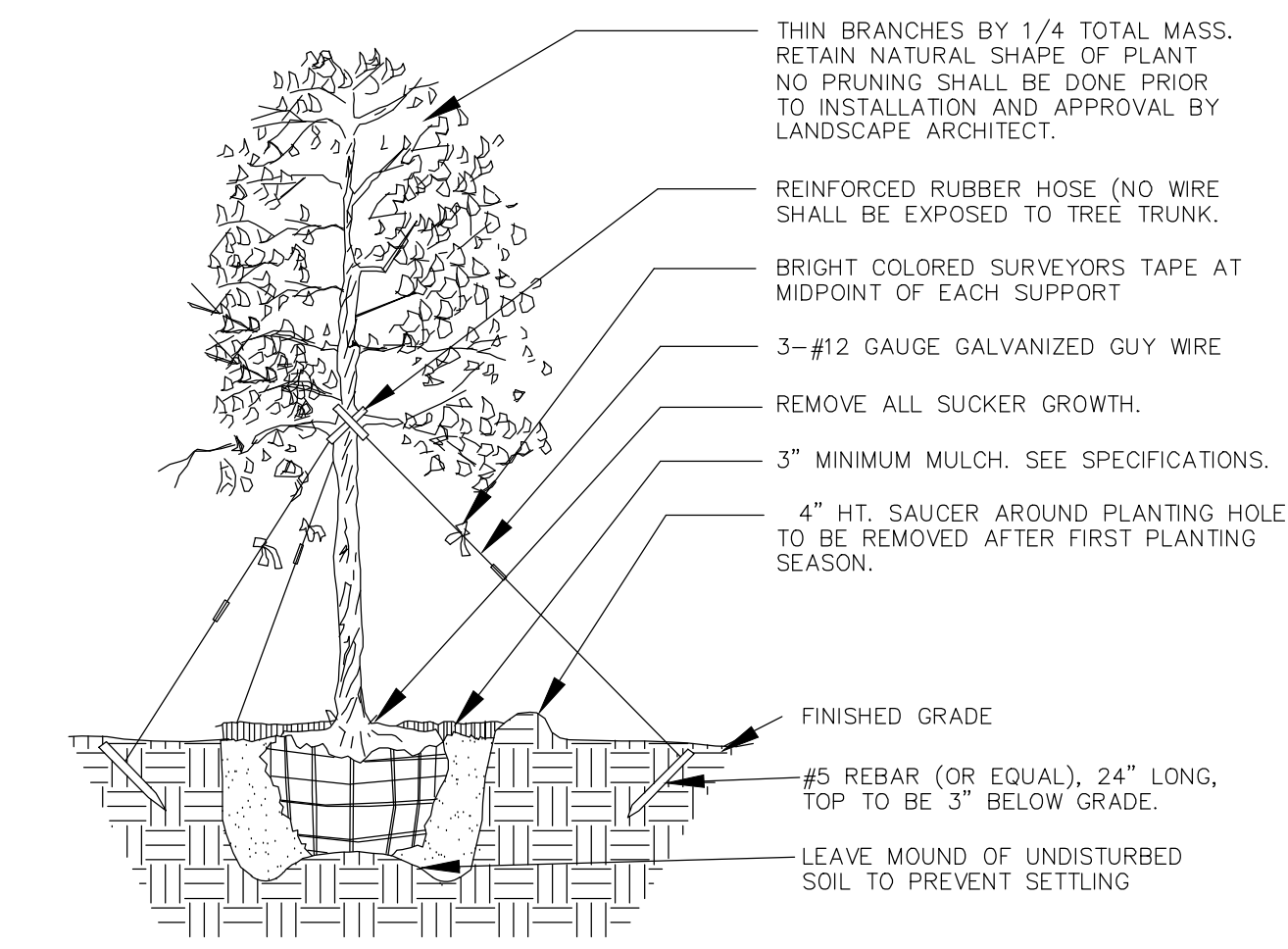

**Tree Planting**

- SEE SPECIFICATIONS FOR BACKFILL MIXTURE AND FERTILIZATION.
- BRACING - SPECIAL SITE CONDITIONS MAY REQUIRE MODIFICATION TO BRACING TECHNIQUE. LANDSCAPE CONTRACTOR WILL ADEQUATELY BRACE (OR WIRE) ALL TREES TO PREVENT EXCESSIVE MOVEMENT & MAINTAIN A VERTICAL POSITION.

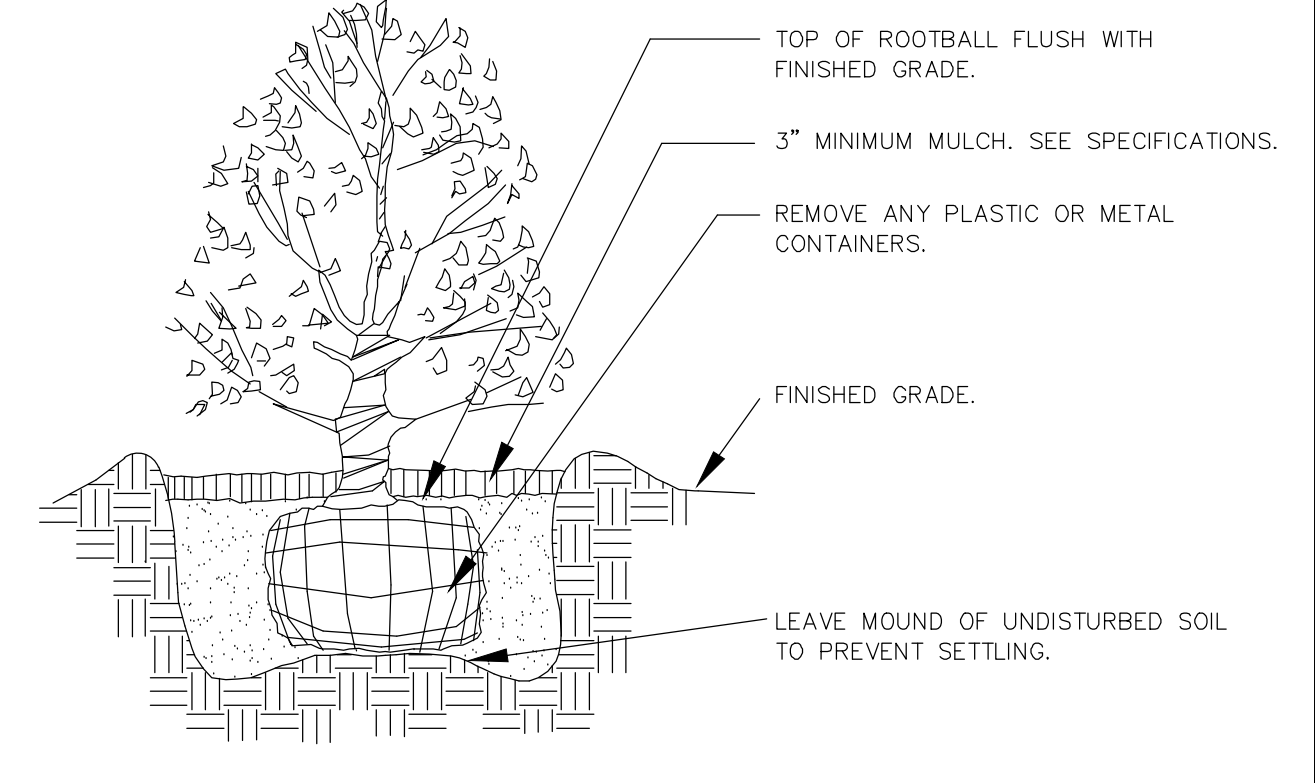

**Shrub Planting**

\* SEE SPECIFICATIONS FOR BACKFILL MIXTURE AND FERTILIZATION.

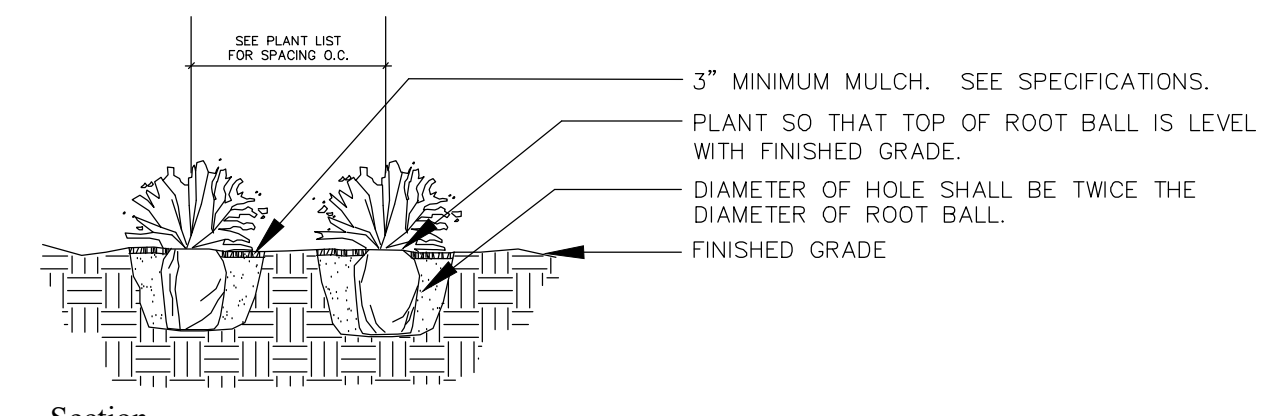

**Section**

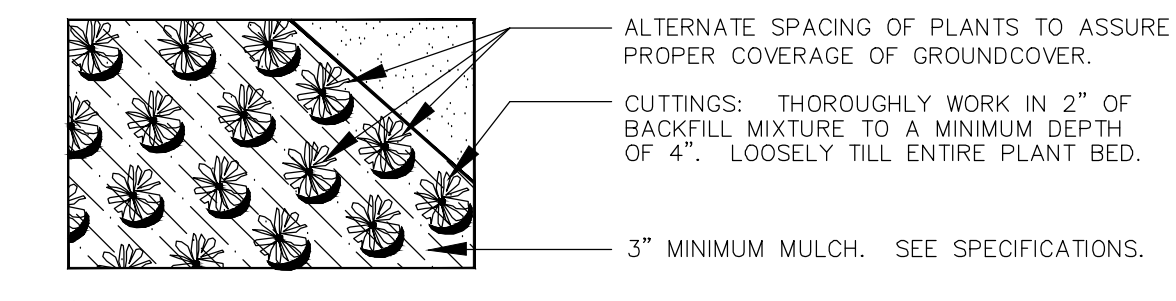

**Plan**

**Groundcover Planting**

\* SEE SPECIFICATIONS FOR BACKFILL MIXTURE AND FERTILIZATION.

**ENTRANCE MONUMENT PLANTING PLAN**

PLANT SCHEDULE MASON RIDGE							
TREES	QTY	BOTANICAL / COMMON NAME	CALIPER	ROOT CONT.	HEIGHT	SPREAD	NOTES
JC	6	JUNIPERUS CHINENSIS 'BLUE POINT' / BLUE POINT JUNIPER	----	CONT.	6'-8'	----	FULL & DENSE
SHRUBS	QTY	BOTANICAL / COMMON NAME	SIZE	ROOT CONT.	HEIGHT	SPREAD	NOTES
DX	6	DISTYLIUM X 'PHIDIST-V' / FIRST EDITIONS® CINNAMON GIRL® DISTYLIUM	#7	CONT.	24"-30"	----	FULL & DENSE
GJ	10	GARDENIA JASMINOIDES 'FROSTPROOF' / FROSTPROOF GARDENIA	#10	CONT.	24"-30"	30"-36"	FULL & DENSE
PB	6	PENNISETUM ALOPECUROIDES 'LITTLE BUNNY' / LITTLE BUNNY FOUNTAIN GRASS	#3	CONT.	----	----	FULL & DENSE
GROUND COVERS	QTY	BOTANICAL / COMMON NAME	SIZE	ROOT CONT.	SPACING	NOTES	
AR	18	AJUGA REPTANS / CARPET BUGLE	#1	CONT.	----	12" O.C.	FULL & DENSE
HX	7	HEMEROCALLIS X 'SUNDAY GLOVES' / SUNDAY GLOVES DAYLILY	#1	CONT.	----	12" O.C.	FULL & DENSE
PS	19	PHLOX SUBULATA 'AMAZING GRACE' / AMAZING GRACE CREEPING PHLOX	#1	CONT.	----	12" O.C.	FULL & DENSE

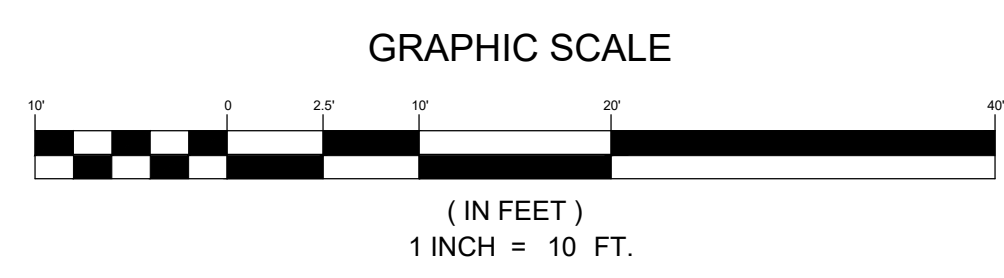

ESP Associates, Inc.  
2200 Gateway Centre Blvd  
Suite 216  
Morriseville, NC 27660  
919-678-1070  
www.espassociates.com  
NC LICENSE #F-1407

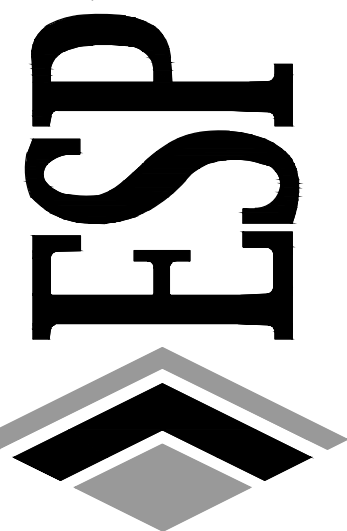

FOR AGENCY  
REVIEW ONLY

NO.	DATE	REVISION	BY

**PLANTING PLAN**

**MASON RIDGE - ENTRANCE MONUMENT**

**CONSTRUCTION DOCUMENTS**

HARNETT COUNTY, NC

D.R. HORTON

PROJECT INFORMATION	
PROJECT MANAGER:	MS
DESIGNED BY:	ALP
DRAWN BY:	BA
PROJECT NUMBER:	24-01007
ORIGINAL DATE:	09/10/2024

SHEET: **L1.0**

S:\RP\1024-Projects\24-01007-Mason Ridge\DR\Horton\24-01007-Monument\Sheets\24-01007-Monument-Planting-Plan.dwg, L1.0 PLANTING PLAN, anytype

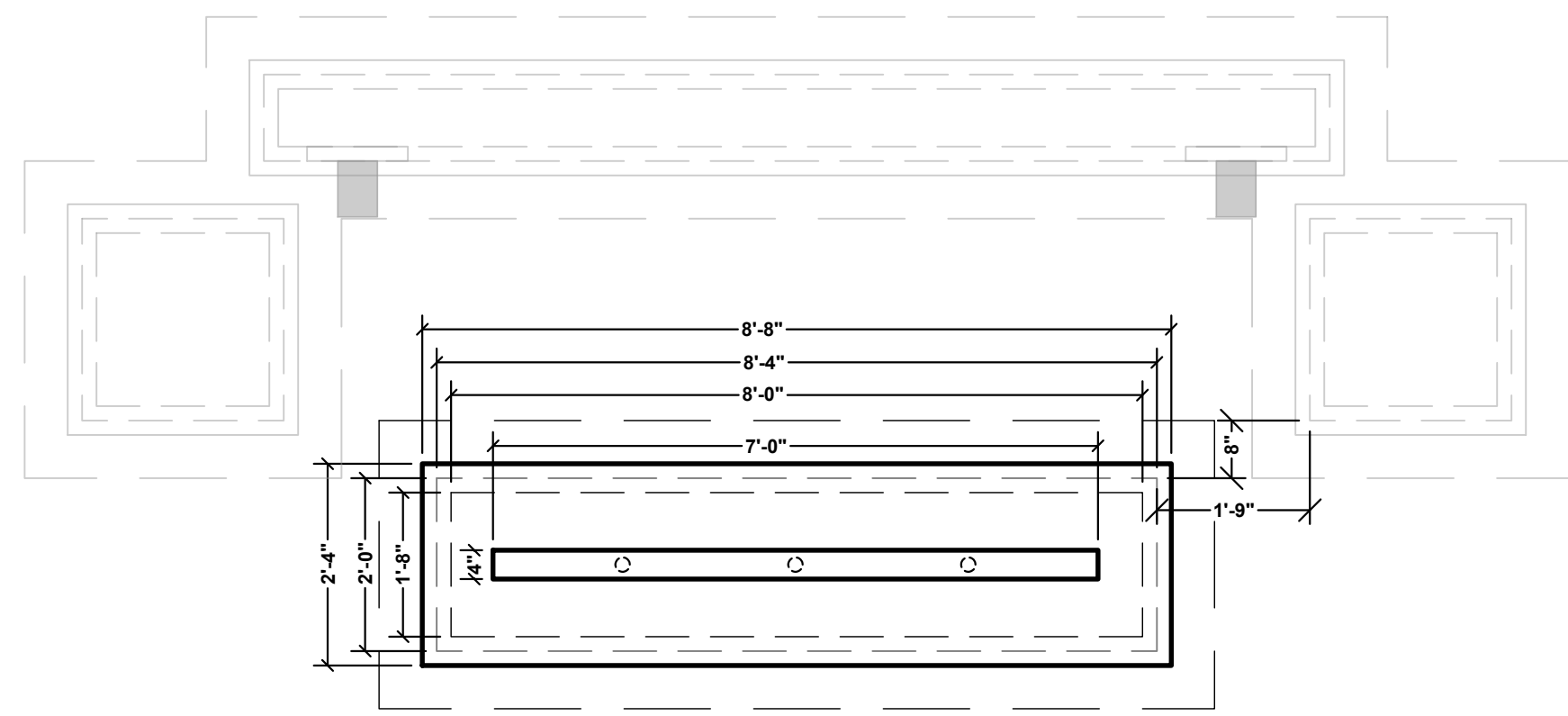

**1** DIMENSIONAL LAYOUT  
SCALE: 1/2" = 1'

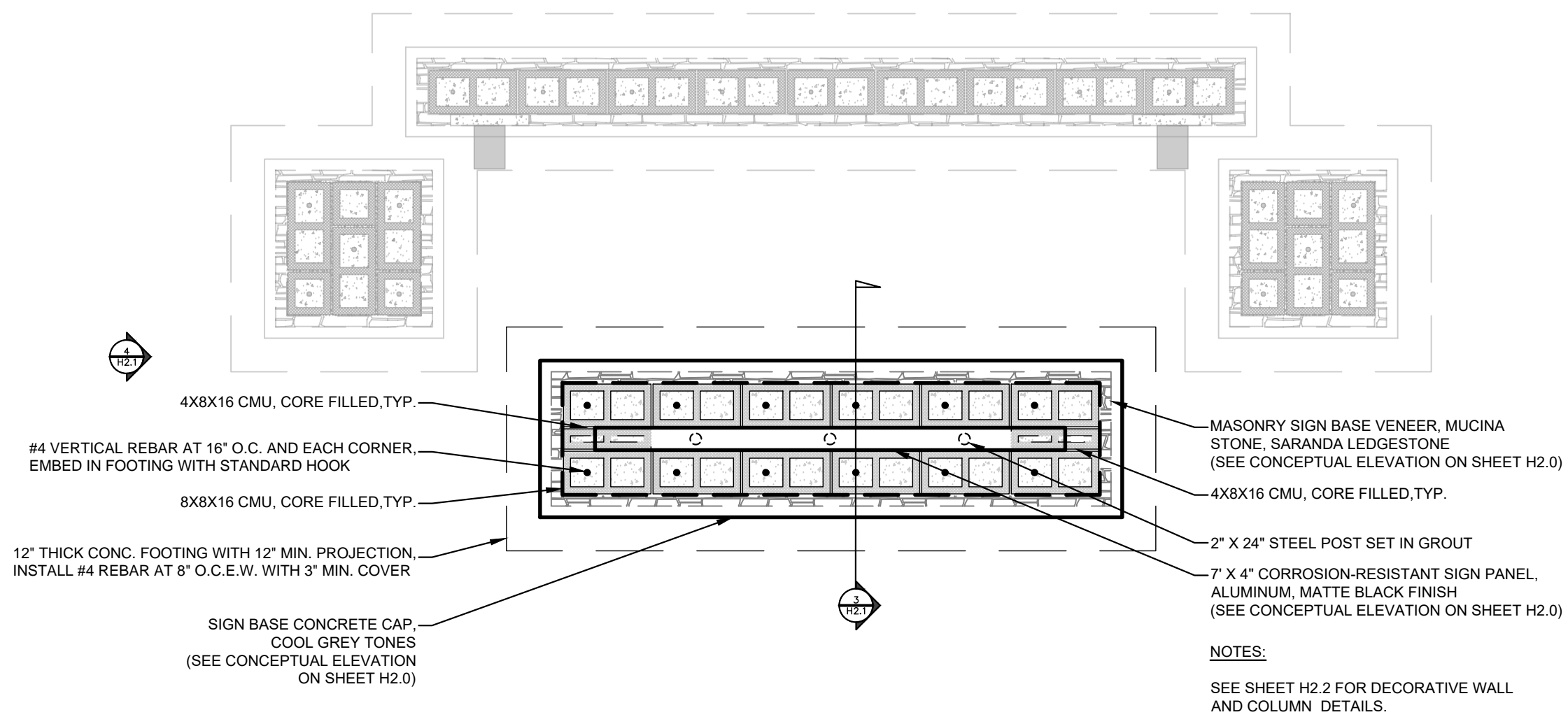

**2** SIGN PLAN  
SCALE: 1/2" = 1'

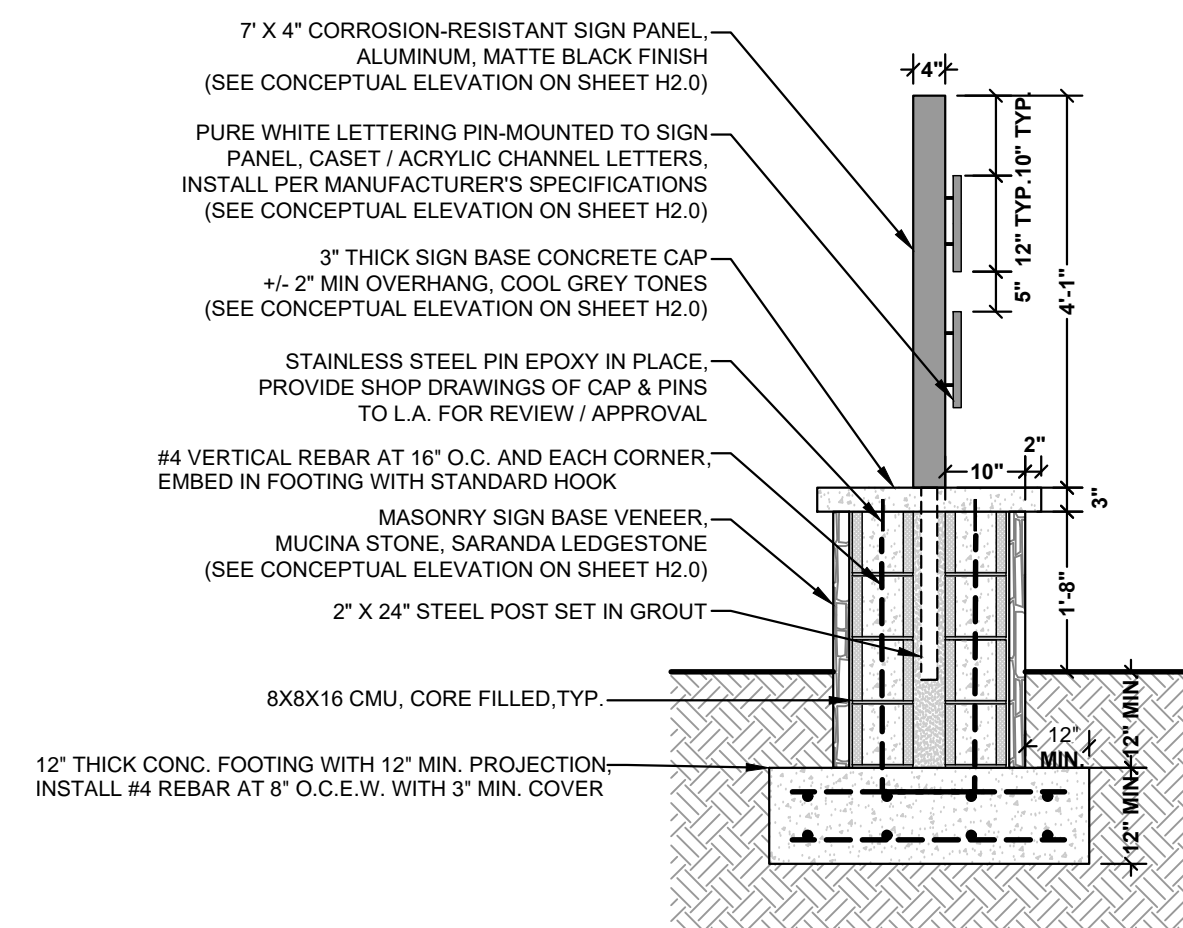

**3** MONUMENT SIGN SECTION  
SCALE: 1/2" = 1'

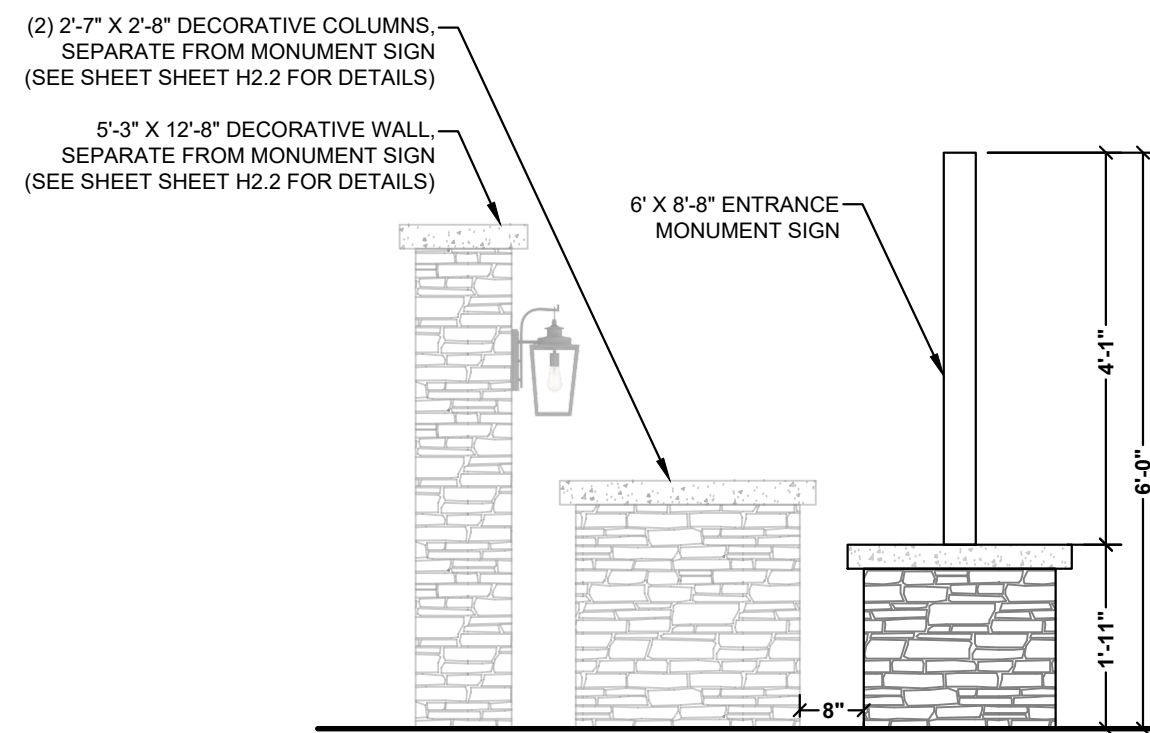

**4** MONUMENT SIGN ELEVATION  
SCALE: 1/2" = 1'

**CONCRETE GENERAL NOTES:**

EXCEPT WHERE OTHERWISE NOTED, FOR ALL CONCRETE, THE PROPORTIONS OF CEMENT, AGGREGATE, AND WATER TO ATTAIN REQUIRED PLASTICITY AND COMPRESSIVE STRENGTH SHALL BE IN ACCORDANCE WITH ACI 318 CODE. CONCRETE SHALL BE 2,500 PSI IN 28 DAYS FOR FOOTINGS

**GENERAL NOTES**

- 1) All rebar splices shall be a minimum of 2'-0" unless otherwise noted.
- 2) Shallow foundations are designed for an assumed soil bearing capacity of 2,000 psi. The contractor is responsible for notifying the Engineer of Record if any soils are found to be unsuitable for this bearing capacity. The contractor is responsible for obtaining soil testing to ensure that the bearing capacity of the soil meets or exceeds this value. All fill is to be compacted to 95% density as measured by the Standard Proctor Test (ASTM D-1557).
- 3) All footing excavations shall be neat, straight, and level in the proper elevations to receive the concrete. Excessive variations in the dimensions of footings or slabs will not be permitted. Reinforcing steel and mesh shall be accurately placed and supported to maintain their position during the concrete pouring. Edge forms shall be used for concrete that will be exposed.
- 4) Masonry construction shall comply with the provisions of ACI 530. Mortar shall comply with ASTM C270. Minimum corrosion protection of joint reinforcement and anchor ties shall comply with ASTM A641, Class 3.



**Residential Structures, P.C.**  
Engineering and Design  
Charlotte: 704-332-5460  
Charleston: 843-406-7174  
Myrtle Beach/Florence: 704-301-9621  
www.residentialstructurespc.com

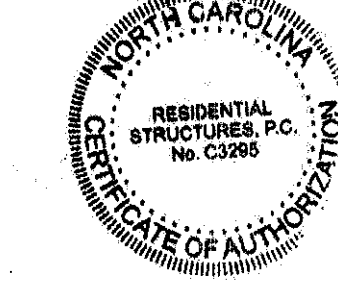
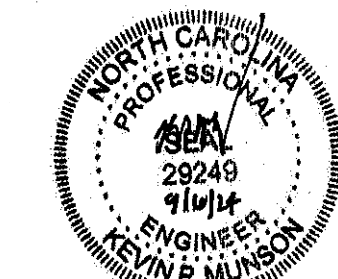

**RESIDENTIAL STRUCTURES, P.C.**  
3416 N. Daniels Rd.  
Charlotte, N.C. 28209  
Soil For Structural Only

ENTRANCE MONUMENT DETAILS

MASON RIDGE - ENTRANCE MONUMENT  
CONSTRUCTION DOCUMENTS

HARNETT COUNTY, NC  
D.R. HORTON

REV. DATE DESCRIPTION  
DESIGNER:

SCALE:

DATE:

SHEET:

S-1

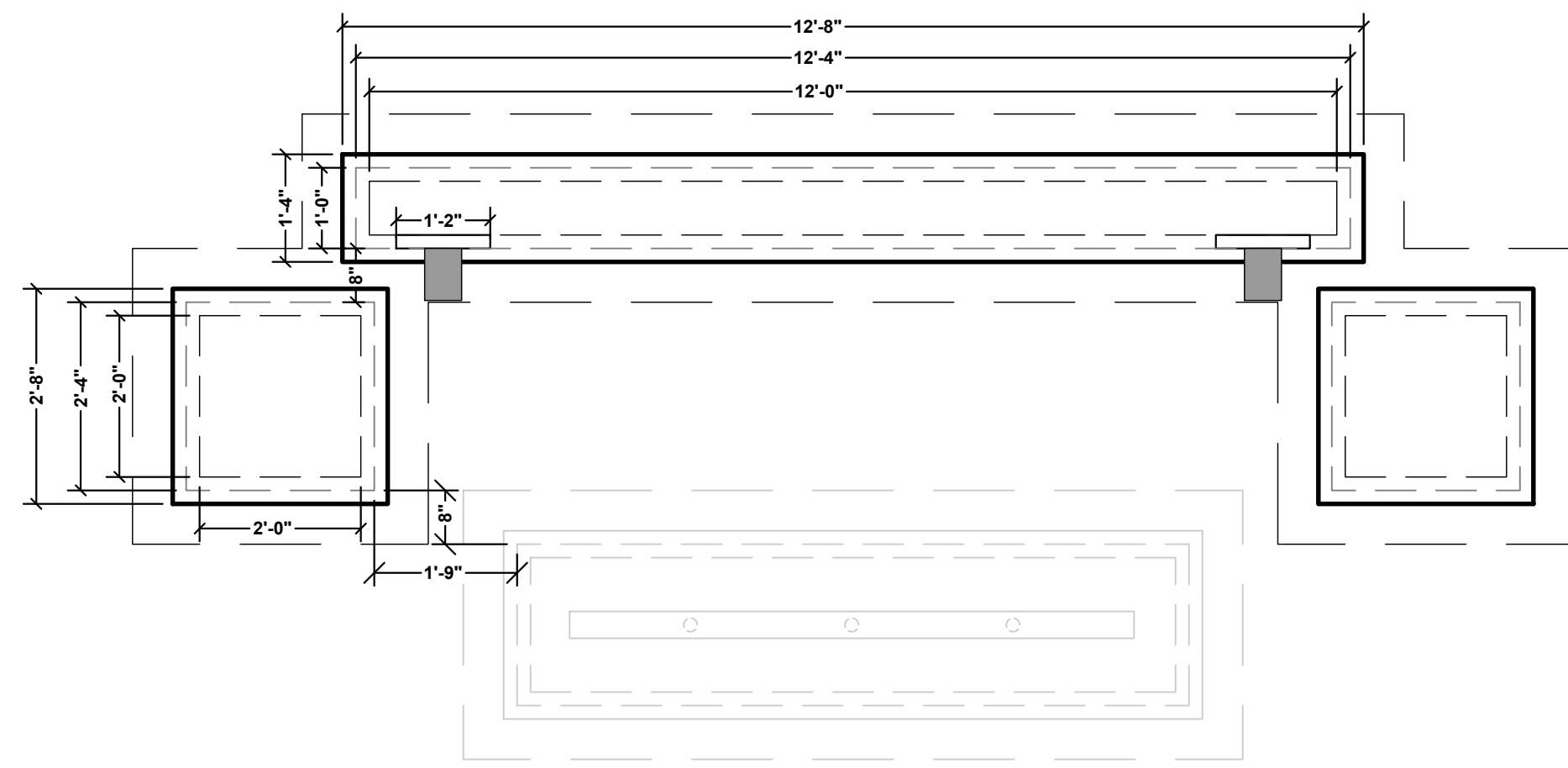

**1 DIMENSIONAL LAYOUT**  
SCALE: 1/2" = 1'

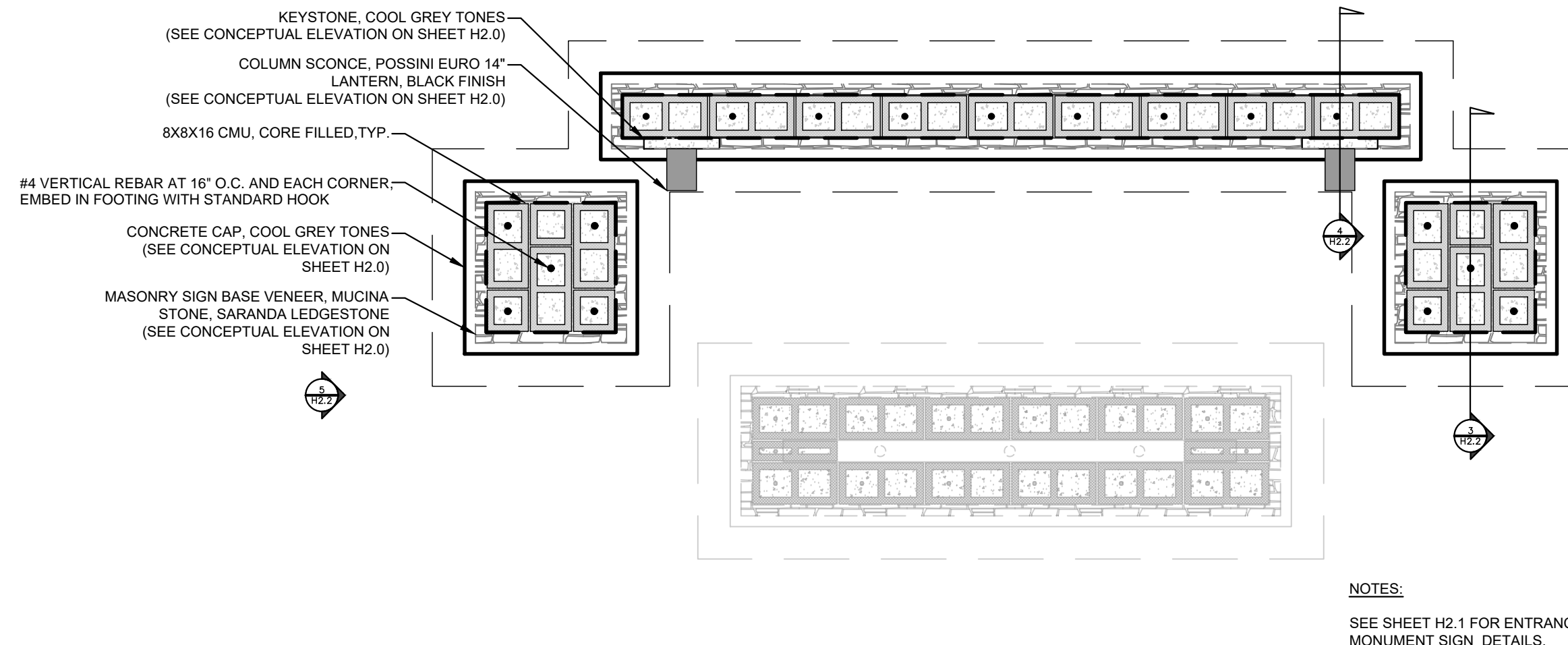

**2 WALL / COLUMN PLAN**  
SCALE: 1/2" = 1'

NOTES:  
SEE SHEET H2.1 FOR ENTRANCE MONUMENT SIGN DETAILS.

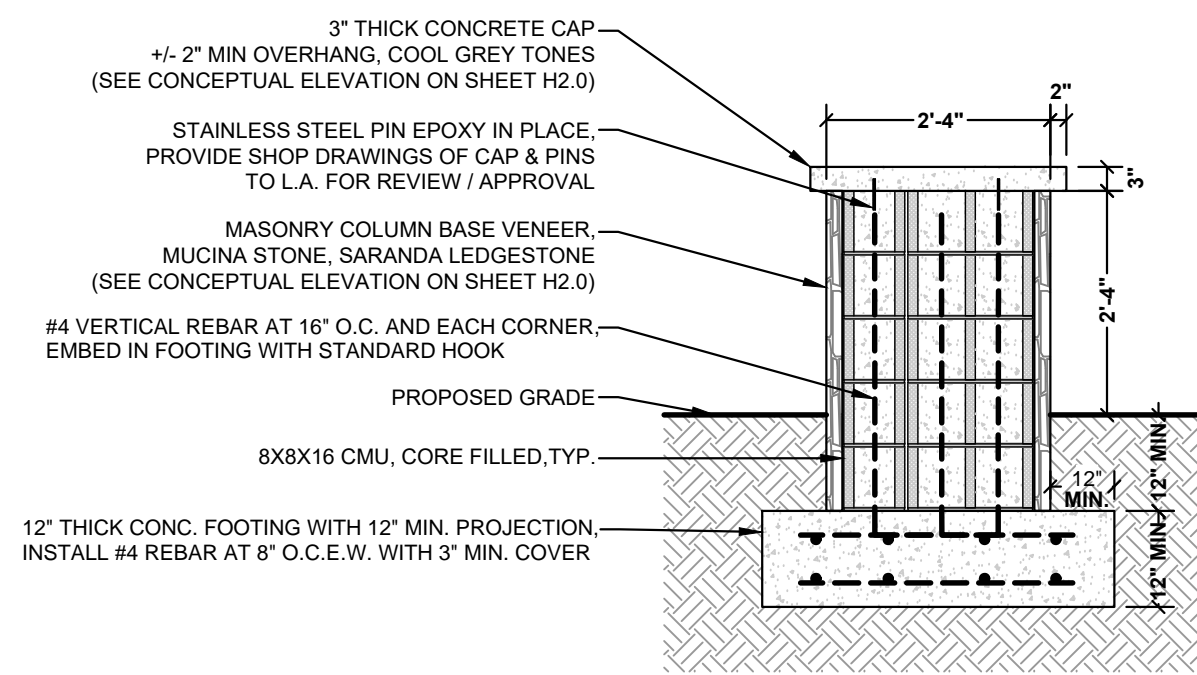

**3 COLUMN : SECTION**  
SCALE: 1/2" = 1'

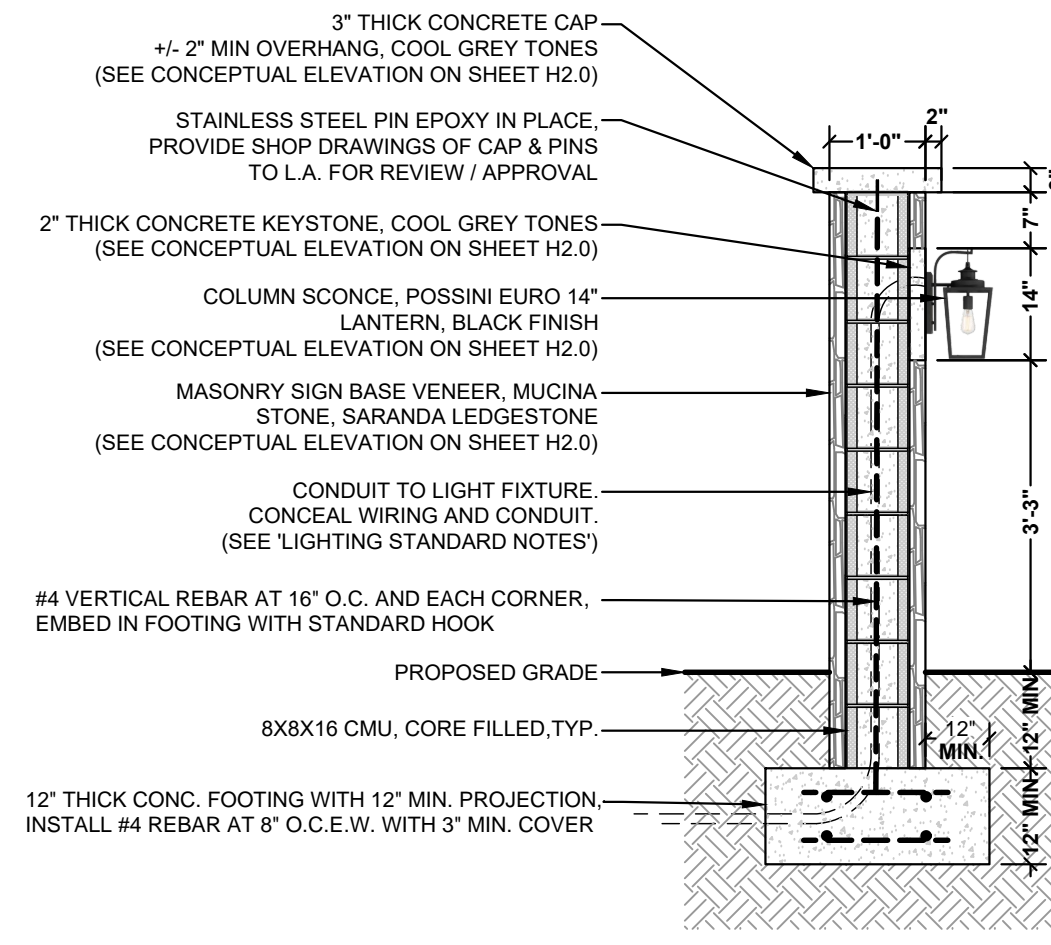

**4 WALL : SECTION**  
SCALE: 1/2" = 1'

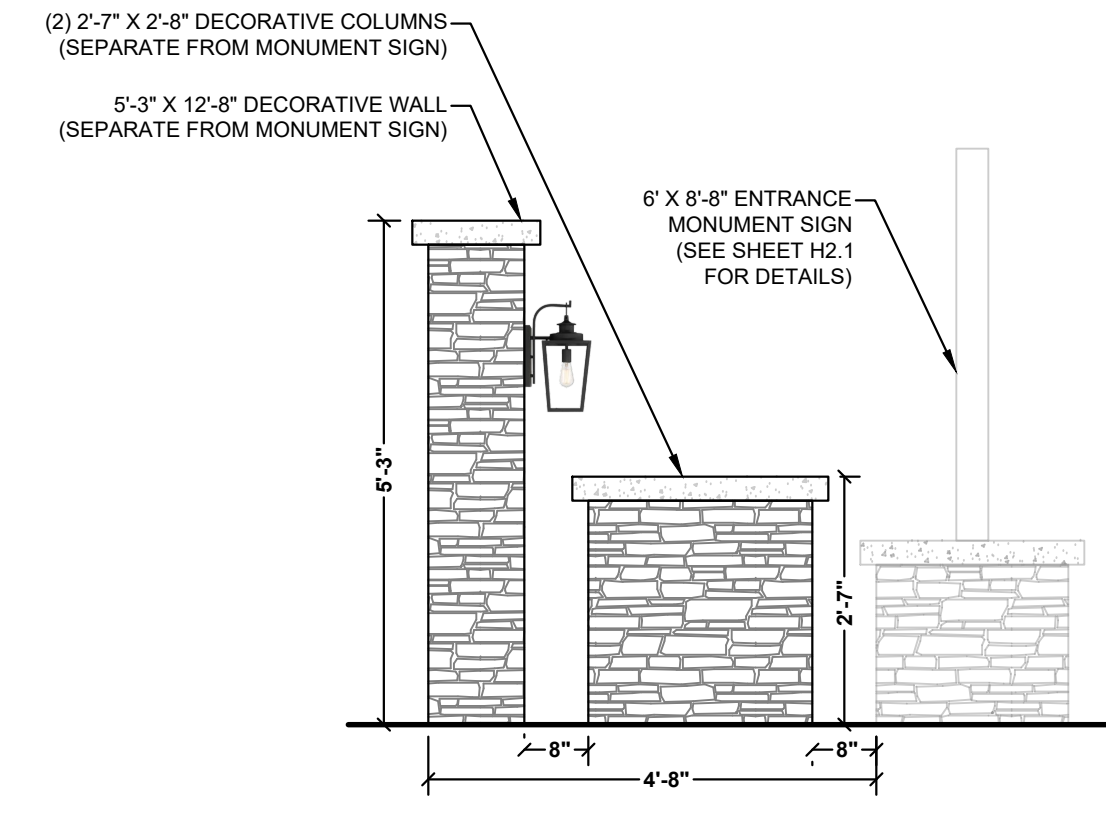

**5 WALL / COLUMN ELEVATION**  
SCALE: 1/2" = 1'

**CONCRETE GENERAL NOTES:**

EXCEPT WHERE OTHERWISE NOTED, FOR ALL CONCRETE, THE PROPORTIONS OF CEMENT, AGGREGATE, AND WATER TO ATTAIN REQUIRED PLASTICITY AND COMPRESSIVE STRENGTH SHALL BE IN ACCORDANCE WITH ACI 318 CODE. CONCRETE SHALL BE 2,500 PSI IN 28 DAYS FOR FOOTINGS

**GENERAL NOTES**

- All rebar splices shall be a minimum of 2'-0" unless otherwise noted.
- Shallow foundations are designed for an assumed soil bearing capacity of 2,000 psi. The contractor is responsible for notifying the Engineer of Record if any soils are found to be unsuitable for this bearing capacity. The contractor is responsible for obtaining soil testing to ensure that the bearing capacity of the soil meets or exceeds this value. All fill is to be compacted to 95% density as measured by the Standard Proctor Test (ASTM D-1557).
- All footing excavations shall be neat, straight, and level in the proper elevations to receive the concrete. Excessive variations in the dimensions of footings or slabs will not be permitted. Reinforcing steel and mesh shall be accurately placed and supported to maintain their position during the concrete pouring. Edge forms shall be used for concrete that will be exposed.
- Masonry construction shall comply with the provisions of ACI 530. Mortar shall comply with ASTM C270. Minimum corrosion protection of joint reinforcement and anchor ties shall comply with ASTM A641, Class 3.



**Residential Structures, P.C.**  
Engineering and Design  
Charlotte: 704-332-5460  
Charleston: 843-406-7174  
Myrtle Beach/Florence: 704-301-9521  
www.residentialstructurespc.com

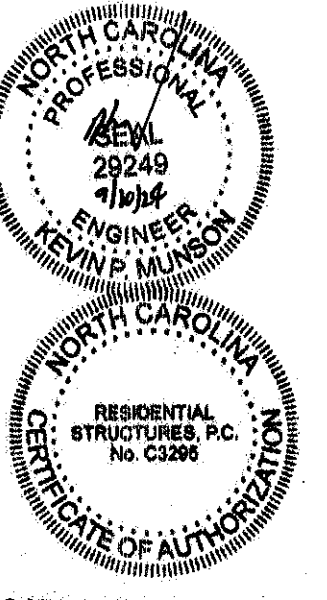

**RESIDENTIAL STRUCTURES, P.C.**  
3410 N. Davidson St.  
Charlotte, N.C. 28205  
Soil For Structural Only

DECORATIVE MASONRY DETAILS  
MASON RIDGE - ENTRANCE MONUMENT  
CONSTRUCTION DOCUMENTS  
D.R. HORTON  
HARNETT COUNTY, NC

REV. DATE DESCRIPTION  
DESIGNER:

SCALE:

DATE:

SHEET:

S-2