

## SIGN ELEVATION

SCALE 3/8" = 1'-0"

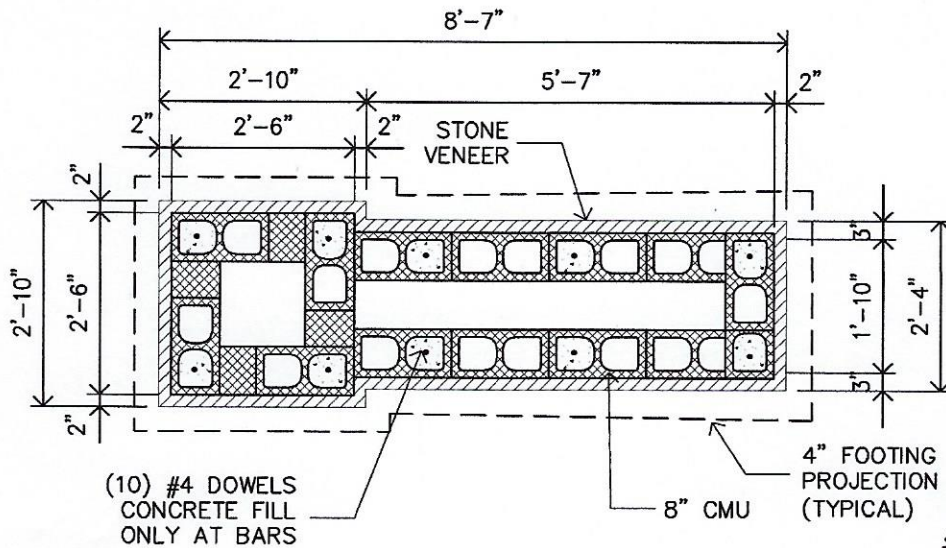

## SIGN PLAN

SCALE 3/8" = 1'-0"

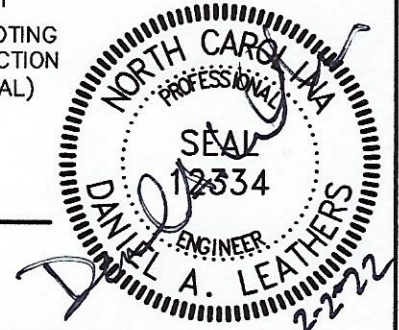

**LEI LEATHERS ENGINEERING, INC.**  
 203 HAYDEN PLACE  
 HIGH POINT, NC 27260  
 PHONE (336) 454-2037

P.O. BOX 5187  
 HIGH POINT, NC 27262  
 FAX (336) 454-2046

### NOTES:

1. CONCRETE MASONRY UNITS: ASTM C90, TYPE 1 LIGHT WEIGHT
2. REBAR: GRADE 60
3. CONCRETE: 3000 PSI
4. MORTAR: TYPE S
5. JOINT REINFORCEMENT: 16" SPACING
6. PRESUMPTIVE SOIL BEARING = 2000 PSF
7. ULTIMATE DESIGN WIND SPEED = 115 MPH

Project: PURFOY PLACE

14 LAMBERT LANE, FUQUAY VARINA, NC 27526

Description: MONUMENT SIGN FOUNDATION

By: DAL

Date: 2/2/22

Job No. 22008