



STATE OF NORTH CAROLINA
DEPARTMENT OF TRANSPORTATION

ROY COOPER
GOVERNOR

J. ERIC BOYETTE
SECRETARY

December 1, 2020

Ms. Kathryn White Eagle
Representative for Orchard Crest Subdivision Residents
44 Orchard Crest Circle
Sanford, North Carolina 27332

SUBJECT: Encroachment Agreement on SR 1115 (Buffalo Lake Road) and SR 2171
(Orchard Crest Circle) in Harnett County (E062-043-20-00418).

Dear Sir:

Attached is an approved R/W form 16.1A and plans for the installation of a new breakaway sign inside the existing island to replace old sign that was damaged by a car with associated appurtenances on SR 1115 (Buffalo Lake Road) and SR 2171 (Orchard Crest Circle) in Harnett County as shown on the attached plans (Orchard Crest Subdivision Marker).

Location:

Route	At a point	Towards
SR 1115/ SR 2171	At the intersection of SR 1115 (Buffalo Lake Road) and SR 2171 (Orchard Crest Circle)	33'± west

This encroachment is approved subject to the following:

Pre-Construction

[Contact Offices & Outside Agency issues/contacts/info](#)

1. Approval may be rescinded upon failure to follow any of the provisions in this permit and may be considered a violation of the encroachment agreement.
2. The Encroaching party or their contractor shall provide the following notices prior to construction activity within the NCDOT Right of Way:
 - a. Three (3) business days advance phone call Mr. Earl Locklear, Assistant District Engineer at telephone (910) 364-0601 or email to elocklear@ncdot.gov to the District Engineer's office.

Failure to provide these notifications prior to beginning construction is subject to the Division Engineer's discretion to cease construction activity for this encroachment. NCDOT reserves the right to cease any construction or maintenance work associated with this installation by the encroaching party until the construction or maintenance meets the satisfaction of the Division Engineer or their representative.

- 3. The encroaching party's construction contractor must submit the NCDOT Workforce Safety Plan for Encroachment Activities: COVID-19 form to the District Engineer prior to construction. Construction within nor access to the right of way shall not commence until such time as the required Workplace Safety plans has been submitted to the District office.**
4. Prior to beginning work, it is the requirement of the Encroaching Party to contact the appropriate Utility Companies involved and make arrangements to adjust or relocate any utilities that conflict with the proposed work.
5. It shall be the responsibility of the encroaching party to determine the location of utilities within the encroachment area. NCGS § 87-115 through § 87-130 of the Underground Utility Safety and Damage Prevention Act requires underground utilities to be located by calling 811 prior to construction. The encroaching party shall be responsible for notifying other utility owners and providing protection and safeguards to prevent damage or interruption to existing facilities and maintain access to them.
6. The encroaching party shall notify the appropriate municipal office prior to beginning any work within the municipality's limits of jurisdiction.
7. Excavation within 1000 feet of a signalized intersection will require notification by the encroaching party to the Division Traffic Engineer at telephone number (910) 364-0606 no less than one week prior to beginning work. All traffic signal or detection cables must be located prior to excavation. Cost to replace or repair NCDOT signs, signals, pavement markings or associated equipment and facilities shall be the responsibility of the encroaching party.
8. This agreement does not authorize installations within nor encroachment onto railroad rights of way. Permits for installations within railroad right of way must be obtained from the railroad and are the responsibility of the encroaching party.
9. At the option of the District Engineer, a preconstruction meeting including representatives of NCDOT, the encroaching party, contractors and municipality, if applicable, shall be required. A pre-construction conference held between a municipality (or other facility owner) and a contractor without the presence of NCDOT personnel with subsequent construction commencing may be subject to NCDOT personnel ceasing any work on NCDOT right-of-way related to this encroachment until such meeting is held. Contact the District office to schedule.
10. At the discretion of the District Engineer, a NOTIFICATION FOR UTILITY / NON-UTILITY ENCROACHMENT WITHIN NCDOT R/W form (See corresponding attachment) with the scheduled pre-construction meeting and associated construction schedule details must be completed and submitted to the District Engineer's office a minimum of one week prior to construction.
11. At the discretion of the District Engineer, the encroaching party (not the utility contractor) shall make arrangements to have a qualified inspector, under the supervision of a Professional Engineer registered in North Carolina, on site at all times during construction. The registered Professional Engineer shall be required to submit a signed and PE sealed certification that the utility was installed in accordance with the encroachment agreement.

Legal & Right-of-Way Issues

12. This approval and associated plans and supporting documents shall not be interpreted to allow any design change or change in the intent of the design by the Owner, Design Engineer, or any of their representatives. Any revisions or changes to these approved plans or intent for construction must be obtained in writing from the Division Engineer's office or their representative prior to construction or during construction, if an issue arises during construction to warrant changes.
13. NCDOT does not guarantee the right of way on this road, nor will it be responsible for any claim for damages brought about by any property owner by reason of this installation. It is the responsibility of the encroaching party to verify the right of way.
14. Prior to the approval of any privately maintained facility within NCDOT right of way which the State of North Carolina is not the fee simple owner, written permission that each and every property owner affected by the installation shall be provided to NCDOT by the encroaching party. (See corresponding attachment.)
15. Encroaching party shall be responsible for obtaining all necessary permanent and/or temporary construction, drainage, utility and/or sight distance easements.
16. All Right of Way and easements necessary for construction and maintenance shall be dedicated to NCDOT with proof of dedication furnished to the District Engineer prior to beginning work.
17. No commercial advertising shall be allowed within NCDOT Right of Way.
18. The encroaching party shall obtain proper approval from all affected pole owners prior to attachment to any pole.
19. The installation within the Control of Access fence shall not adversely affect the design, construction, maintenance, stability, traffic safety or operation of the controlled access highway, and the utility must be serviced without access from the through-traffic roadways or ramps.

Bonds

20. A Performance and Indemnity Bond in the amount of \$0.00 shall be posted with the District Engineer's Office by the Party of the Second Part prior to beginning any work within the NCDOT Right of Way. The bond shall be held for a minimum of one year after a satisfactory final inspection of the installation by NCDOT. The bond may be held for a period longer than one year after completion if, in the opinion of NCDOT, the size or complexity of the installation warrants a longer period.
21. The release of the bond is subject to a final inspection by NCDOT. Contact the District office to schedule a Final Inspection and to request release of the bond.

Work Zone Traffic

22. Traffic control shall be coordinated with the District Engineer and the Division Traffic Engineer, Mr. Frank West at telephone (910) 364-0606, prior to construction.

23. WORK ZONE TRAFFIC CONTROL QUALIFICATIONS AND TRAINING PROGRAM

All personnel performing any activity inside the highway right of way are required to be familiar with the NCDOT Maintenance / Utility Traffic Control Guidelines (MUTCG). No specific training course or test is required for qualification in the Maintenance /Utility Traffic Control Guidelines (MUTCG).

All flagging, spotting, or operating Automated Flagger Assist Devices (AFAD) inside the highway right of way requires qualified and trained Work Zone Flaggers. Training for this certification is provided by NCDOT approved training resources and by private entities that have been pre-approved to train themselves.

All personnel involved with the installation of Work Zone Traffic Control devices inside the highway right of way are required to be qualified and trained Work Zone Installers. Training for this certification is provided by NCDOT approved training resources and by private entities that have been pre-approved to train themselves.

All personnel in charge of overseeing work zone Temporary Traffic Control operations and installations inside the highway right of way are required to be qualified and trained Work Zone Supervisors. Training for this certification is provided by NCDOT approved training resources and by private entities that have been pre-approved to train themselves.

For questions and/or additional information regarding this training program please refer to <https://connect.ncdot.gov/projects/WZTC/Pages/Training.aspx> or call the NCDOT Work Zone Traffic Control Section (919) 814-5000.

24. The party of the second part shall employ traffic control measures that are in accordance with the prevailing federal, state, local, and NCDOT policies, standards, and procedures. These policies, standards, and procedures include, but are not limited to the following:
- a. Manual on Uniform Traffic Control Devices (MUTCD) – North Carolina has adopted the MUTCD to provide basic principles and guidelines for traffic control device design, application, installation, and maintenance. North Carolina uses the MUTCD as a minimum requirement where higher supplemental standards specific to North Carolina are not established. Use fundamental principles and best practices of MUTCD (Part 6, Temporary Traffic Control).
 - b. NCDOT Maintenance / Utility Traffic Control Guidelines – This document enhances the fundamental principles and best practices established in MUTCD Part 6, Temporary Traffic Control, incorporating NCDOT-specific standards and details. It also covers important safety knowledge for a wide range of work zone job responsibilities.
25. If the Traffic Control Supervisor determines that portable concrete barrier (PCB) is required to shield a hazard within the clear zone, then PCB shall be designed and sealed by a licensed North Carolina Professional Engineer. PCB plans and design calculations shall be submitted to the District Engineer for review and approval prior to installation.
26. Ingress and egress shall be maintained to all businesses and dwellings affected by the project. Special attention shall be paid to police, EMS and fire stations, fire hydrants, secondary schools, and hospitals.

27. Traffic shall be maintained at all times. All lanes of traffic are to be open during the hours of 7:00 A.M. to 9:00 A.M. and from 4:00 P.M. to 6:00 P.M. Monday through Friday, during any time of inclement weather, **or as directed by the District Engineer**. No lane of traffic shall be closed on holidays, special events, or as directed by the engineer. Any violation of these hours will result in ceasing any further construction by the Encroaching Party or their contractor.
28. Nighttime and weekend operations will NOT be allowed unless written approval is received from the District Engineer. If nighttime or weekend work is allowed or required, all signs must be retro-reflective, and a work zone lighting plan must be submitted for approval prior to construction.
29. Two-way traffic shall be maintained at all times unless designated by the District Engineer. Traffic shall not be rerouted or detoured without the prior written approval from the District Engineer. No utility work will be allowed on state holidays from 7:00 PM the night before through 9:00 AM the day prior to, following or during local events without prior approval from the District Engineer. If the construction is within 1000 feet of a school location or on a designated bus route, the construction shall be coordinated with the school start and end times to avoid traffic delays.
30. Work requiring lane or shoulder closures shall not be performed on both sides of the road simultaneously within the same area.
31. Any work requiring equipment or personnel within 5 feet of the edge of any travel lane of an undivided facility and within 10 feet of the edge of any travel lane of a divided facility shall require a lane closure with appropriate tapers per current *NCDOT Roadway Standard Drawings* or *MANUAL ON UNIFORM TRAFFIC CONTROL DEVICES*.
32. At the discretion of the District Engineer, a traffic control plan shall be developed and submitted under the seal and signature of a Licensed North Carolina Professional Engineer prior to construction. The plan shall be specific to the site and adequately detailed. Issues such as the close proximity to intersections shall be addressed.
33. Temporary and final pavement markings are the responsibility of the encroaching party. Final pavement markings and sign plans shall be submitted with the encroachment request to the Division Traffic Engineer prior to construction. Final pavement markings shall be thermoplastic unless otherwise directed by the Division Traffic Engineer or District Engineer.
34. Any pavement markings that are damaged or obliterated shall be restored by the encroaching party at no expense to NCDOT.
35. Sidewalk closures shall be installed as necessary. Pedestrian traffic shall be detoured around these closures and shall be signed appropriately and in accordance with The American with Disabilities Act Accessibility Guidelines. The encroaching party must adhere to the guidelines for accommodating pedestrians in encroachment work zones as described in the NCDOT Pedestrian Work Zone Accommodations Training found at <https://www.youtube.com/watch?v=AOuYa5IW3dg&feature=youtu.be>

Roadside Environmental

36. The encroaching party shall comply with all applicable Federal, State and local environmental regulations and shall obtain all necessary Federal, State and local environmental permits, including but not limited to, those related to sediment control, stormwater, wetland, streams, endangered species and historical sites. Additional information can be obtained by contacting the NCDOT Roadside Environmental Engineer regarding the North Carolina Natural Heritage Program or the United States Fish and Wildlife Services. Contact the Division Roadside Environmental Engineer's Office at (910) 364-0603.
37. When surface area in excess of one acre will be disturbed, the Encroacher shall submit a Sediment and Erosion Control Plan which has been approved by the appropriate regulatory agency or authority prior to beginning any work on the Right of Way. Failure to provide this information shall be grounds for suspension of operations. Proper temporary and permanent measures shall be used to control erosion and sedimentation in accordance with the approved sediment and erosion control plan.
38. The Verification of Compliance with Environmental Regulations (VCER-1) form is required for all non-utility encroachment agreements or any utility encroachments when land disturbance within NCDOT right of way exceeds 1 acre. The VCER-1 form must be PE sealed by a NC registered professional engineer who has verified that all appropriate environmental permits (if applicable) have been obtained and all applicable environmental regulations have been followed.
39. All erosion control devices and measures shall be constructed, installed, maintained, and removed by the Encroacher in accordance with all applicable Federal, State, and Local laws, regulations, ordinances, and policies. Permanent vegetation shall be established on all disturbed areas in accordance with the recommendations of the Division Roadside Environmental Engineer. All areas disturbed (shoulders, ditches, removed accesses, etc.) shall be graded and seeded in accordance with the latest *NCDOT Standards Specifications for Roads and Structures* and within 15 calendar days with an approved NCDOT seed mixture (all lawn type areas shall be maintained and reseeded as such). Seeding rates per acre shall be applied according to the Division Roadside Environmental Engineer. Any plant or vegetation in the NCDOT planted sites that is destroyed or damaged as a result of this encroachment shall be replaced with plants of like kind or similar shape.
40. No trees within NCDOT shall be cut without authorization from the Division Roadside Environmental Engineer. An inventory of trees measuring greater than 4 caliper inches (measured 6" above the ground) is required when trees within C/A right of way will be impacted by the encroachment installation. Mitigation is required and will be determined by the Division Roadside Environmental Engineer's Office.
41. Prior to installation, the Encroaching Party shall contact the District Engineer to discuss any environmental issues associated with the installation to address concerns related to the root system of trees impacted by boring or non-utility construction of sidewalk, roadway widening, etc.

42. The applicant is responsible for identifying project impacts to waters of the United States (wetlands, intermittent streams, perennial streams and ponds) located within the NCDOT right-of-way. The discharge of dredged or fill material into waters of the United States requires authorization from the United States Army Corps of Engineers (USACE) and certification from the North Carolina Division of Water Quality (NCDWQ). The applicant is required to obtain pertinent permits or certification from these regulatory agencies if construction of the project impacts waters of the United States within the NCDOT right-of-way. The applicant is responsible for complying with any river or stream Riparian Buffer Rule as regulated by the NCDWQ. The Rule regulates activity within a 50-foot buffer along perennial streams, intermittent streams and ponds. Additional information can be obtained by contacting the NCDWQ or the USACE.
43. The contractor shall not begin the construction until after the traffic control and erosion control devices have been installed to the satisfaction of the Division Engineer or their agent.
44. The contractor shall perform all monitoring and record keeping and any required maintenance of erosion and sediment control measures to maintain compliance with stormwater regulations.

Construction

General

45. An executed copy of the encroachment agreement, provisions and approved plans shall be present at the construction site at all times. If safety or traffic conditions warrant such an action, NCDOT reserves the right to further limit, restrict or suspend operations within the right of way.
46. The Encroaching Party and/or their Contractor shall comply with all OSHA requirements. If OSHA visits the work area associated with this encroachment, the District Office shall be notified by the encroaching party immediately if any violations are cited.
47. Any REVISIONS marked in RED on the attached non-PE sealed plans shall be incorporated into and made part of the approved encroachment agreement.
48. All disturbed areas are to be fully restored to current NCDOT minimum roadway standards or as directed by the Division Engineer or their representative. Disturbed areas within NCDOT Right-of-Way include, but not limited to, any excavation areas, pavement removal, drainage or other features.
49. The encroaching party shall notify the Division Engineer or their representative immediately in the event any drainage structure is blocked, disturbed or damaged. All drainage structures disturbed, damaged or blocked shall be restored to its original condition as directed by the Division Engineer or their representative.
50. A minimum of 5 feet clearance is required for utility installations beneath or near drainage pipes, headwalls, and a minimum of two-foot clearance below the flowline of streams. If directional drilling, a minimum ten-foot clearance distance is required from drainage structures and a minimum of 5 feet below flowline of streams.

51. At points where the utility is placed under existing storm drainage, the trench will be backfilled with excavatable flowable fill up to the outside diameter of the existing pipe.
52. Unless specified otherwise, during non-working hours, equipment shall be located away from the job site or parked as close to the right of way line as possible and be properly barricaded in order not to have any equipment obstruction within the Clear Recovery Area. Also, during non-working hours, no parking or material storage shall be allowed along the shoulders of any state-maintained roadway.
53. No access to the job site, parking or material storage shall be allowed along or from the **Control of Access Roadway**.
54. Guardrail removed or damaged during construction shall be replaced or repaired to its original condition, meeting current NCDOT standards or as directed by the Division Engineer or their representative.
55. The resetting of the Control of Access fence shall be in accordance with the applicable NCDOT standard and as directed by the Division Engineer or their representative.
56. Right of Way monuments disturbed during construction shall be referenced by a registered Land Surveyor and reset after construction.
57. All traffic signs moved during construction shall be reinstalled as soon as possible to the satisfaction of the Division Engineer or their representative.
58. Any utility markers, cabinets, pedestals, meter bases and services for meter reading required shall be as close to the Right of Way line as possible. If it is not feasible to install at or near Right of Way line, then written approval shall be obtained from NCDOT prior to installation.
59. Detection tape, where required by NCGS § 87-115 through § 87-130 of the Underground Utility Safety and Damage Prevention Act, shall be buried in the trench approximately 1 foot above the installed facility. Where conduit is installed in the right of way and is not of ferrous material, locating tape or detection wire shall be installed with the conduit.
60. All driveways disturbed during construction shall be returned to a state comparable with the condition of the driveways prior to construction.
61. Any proposed driveway connections onto NCDOT roadways will require an approved driveway permit. The approval of this encroachment agreement does not constitute approval of any proposed driveway connections. For further information, contact Mr. Troy L. Baker, Senior Assistant District Engineer at (910) 364-0601.
62. Conformance with driveway permit review should be required in conjunction with this encroachment agreement. In the event there is a conflict between the driveway permit and the encroachment agreement, the District Engineer should resolve the conflict and notify the parties involved.
63. If the approved method of construction is unsuccessful and other means are required, prior approval must be obtained through the District Engineer before construction may continue.

Engineering

64. All traffic control, asphalt mixes, structures, construction, workmanship and construction methods, and materials shall be in compliance with the most-recent versions of the following resources: *ASTM Standards*, *Manual on Uniform Traffic Control Devices*, *NCDOT Utilities Accommodations Manual*, *NCDOT Standard Specifications for Roads and Structures*, *NCDOT Roadway Standard Drawings*, *NCDOT Asphalt Quality Management System* manual, **and the approved plans.**
65. Prior approval for any blasting must be obtained from the Division Engineer or their representative.
66. Regulator stations, metering stations, cathodic test stations, and anode beds are not permitted within NCDOT right of way. Header wires are permitted.
67. Non-Utility Communication and Data Transmission installations (ground mounted type or Small Cell pole-mounted type) must adhere to guidelines in the Utilities Accommodations Manual and, when located within municipal jurisdictions, are subject to review and approval by municipal ordinances and any additional municipal approval for proximity to historic districts and landmarks. All wiring and related telecommunications work shall conform to the latest regulations by the Federal Communications Commission.
68. All wiring and related electrical work shall conform to the latest edition of the National Electrical Safety Code.

Location within R/W

69. All utility access points, such as manholes, vaults, handholes, splice boxes and junction boxes shall be located as close to the right of way line as possible and shall not be placed in the ditch line, side slopes of the ditches or in the pavement. All manholes, handholes, splice boxes, junction boxes and vaults and covers shall be flush with the ground when located within the vehicle clear zone. Slack loops for telecommunications in industry standard housing units shall be buried a minimum of 18 inches when buried or meet minimum NCDOT vertical and horizontal clearances when installed aerially.
70. Fire Hydrants shall be of the breakaway type. Hydrants shall be placed near the right of way line. In curb and gutter sections with written approval from the District, the hydrants may be placed at 6' behind the back of the curb or minimum 2' back of sidewalk.
71. Luminaire and/or utility poles and guy wires shall be set as close to the Right of Way line as practical and outside the Clear Zone in accordance with the latest version of the AASHTO Roadside Design Guide (See corresponding attachment) or made breakaway in accordance with the requirements of NCHRP Report 350. Any relocation of the utility poles from the original design due to Clear Zone requirements shall require a re-submittal for the utility design.
72. Luminaire and/or utility poles shall be set a minimum of 5'-6" behind face of any guardrail or otherwise sufficiently protected. However, standard placement may be reduced to 3'-6" behind face of guardrail when posts are spaced 3'-1 ½", or where speed limit is less than 55 MPH.

73. Hot box (aka ASSE 1060) or Safe-T-Cover type enclosures covering utility main pipe joints, backflow preventers, valves, vent pipes, cross connections, pumps, grinders, irrigation assemblies, transformers, generators, and other similar large appurtenances shall be located outside sight distance triangles and off of the NCDOT Right-of-Way.
74. Sprinkler heads shall be located a minimum of 10 feet from the edge of pavement, edge of shoulder, or back of curb whichever is greater and shall be directed so that water does not spray or drain on the roadway surface, sidewalk, or passing vehicles at any time. Upon completion of the installation and prior to activation of the system, the Encroacher shall contact the District Engineer to schedule a test of the system to verify the spray pattern. Sprinkler systems shall not be operated during periods of high wind or freezing weather, or to the extent that the subgrade adjacent to the pavement structure becomes saturated. NCDOT reserves the right to require immediate termination and removal of any sprinkler system which in its judgement and opinion adversely affects safety, maintenance, or operation of the roadway.

Excavation

75. Excavation material shall not be placed on pavement.
76. It is the responsibility of the encroaching party or their contractor to prevent any mud/dirt from tracking onto the roadway. Any dirt which may collect on the roadway pavement from equipment and/or truck traffic on site shall be immediately removed to avoid any unsafe traffic conditions.
77. Excavated areas adjacent to pavement having more than a 2” drop shall be safed up at a 6:1 or flatter slope and designated by appropriate delineation during periods of inactivity, including, but not limited to, night and weekend hours. Excavated material shall not be placed on the roadway at any time.
78. The utility shall be installed within 5 feet of the right of way line and outside the 5-foot minimum from travel lane plus theoretical 2:1 slope from the edge of pavement to the bottom of the nearest excavation wall for temporary shoring. If the 2:1 slope plus 5 feet requirement above is met for traffic, then temporary shoring is typically only necessary to protect roadways from damage when a theoretical 1:1 slope from the edge of pavement intersects the nearest excavation wall. This rule of thumb should be used with caution and does not apply to all subsurface conditions, surcharge loadings and excavation geometries. Situations where this 1:1 slope is not recommended include groundwater depth is above bottom of excavation or excavation is deeper than 10 feet or in [Type B or C soils as defined by OSHA Technical Manual](#). Temporary shoring may be avoided by locating trenches, bore pits, and other excavations far enough away from the open travel lane, edge of pavement and any existing structure, support, utility, property, etc. to be protected. Temporary shoring is required when a theoretical 2:1 slope from the bottom of excavation will intersect the existing ground line less than 5 feet from the outside edge of an open travel lane as shown in the figure below or when a theoretical 2:1 slope from the bottom of excavation will intersect any existing structure, support, utility, property, etc. to be protected.

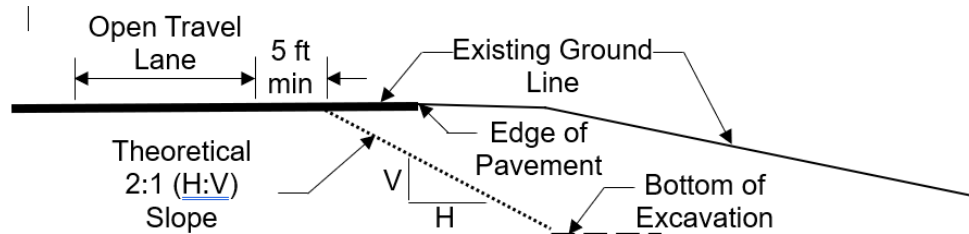

Temporary shoring shall be designed and constructed in accordance with current NCDOT Standard Temporary Shoring provisions (refer to <https://connect.ncdot.gov/resources/Specifications/Pages/2018-Specifications-and-Special-Provisions.aspx> and see SP11 R002).

- a. Temporary excavation shoring, such as sheet piling, shall be installed. The design of the shoring shall include the effects of traffic loads. The shoring system shall be designed and sealed by a licensed North Carolina Professional Engineer. Shoring plans and design calculations shall be submitted to the Division Engineer for review and approval prior to construction. (See NCDOT *Utilities Accommodations Manual* for more information on requirements for shoring plans and design calculations.) **Trench boxes shall not be accepted as temporary shoring and will not be approved for use in instances where shoring is required to protect the highway, drainage structure, and/or supporting pavement or structure foundation.**
- b. All trench excavation inside the limits of the theoretical one-to-one slope, as defined by the policy, shall be completely backfilled and compacted at the end of each construction day. No portion of the trench shall be left open overnight. Any excavation that is not backfilled by the end of the workday must address any safety and traveling public concerns including accommodations for bicycles, pedestrians and persons with disabilities.
- c. The trench backfill material shall meet the Statewide Borrow Criteria. The trench shall be backfilled in accordance with Section 300-7 of the latest *NCDOT Standard Specifications for Roads and Structures*, which basically requires the backfill material to be placed in layers not to exceed 6 inches loose and compacted to at least 95% of the density obtained by compacting a sample in accordance with AASHTO T99 as modified by DOT.
- d. At the discretion of the Division Engineer, a qualified NCDOT inspector shall be on the site at all times during construction. The encroaching party shall reimburse NCDOT for the cost of providing the inspector. If NCDOT cannot supply an inspector, the encroaching party (not the utility contractor) should make arrangements to have a qualified inspector, under the supervision of a licensed North Carolina Professional Engineer, on the site at all times. The Professional Registered Engineer shall certify that the utility was installed in accordance with the encroachment agreement and that the backfill material meets the Statewide Borrow Criteria.
- e. The length of parallel excavation shall be limited to the length necessary to install and backfill one joint of pipe at a time, not to exceed twenty-five (25) feet.

79. All material to a depth of 8 inches below the finished surface of the subgrade shall be compacted to a density equal to at least 100% of that obtained by compacting a sample of the material in accordance with AASHTO T99 as modified by the Department. The subgrade shall be compacted at a moisture content which is approximately that required to produce the maximum density indicated by the above test method. The contractor shall dry or add moisture to the subgrade when required to provide a uniformly compacted and acceptable subgrade. The option to backfill any trenches with dirt or either #57 stone or #78 stone with consolidation with a plate tamp and without a conventional density test may be pursued with the written consent of the District Engineer. If this option is exercised, then roadway ABC stone and asphalt repair as required will also be specified by the District Engineer.

Directional bore

80. Boring equipment will be provided of a type and size to facilitate boring in the local geologic conditions and shall be able to facilitate the encroachment work.

81. When Horizontal Directional Drilling (HDD) is used, the following stipulations apply:

- a. Use drilling fluids as appropriate for the type soils but use of water alone is prohibited. Pump drilling fluids only while drilling or reaming. Directional boring using jetting with a Bentonite (or equivalent material) slurry is recommended. Monitor flow rates to match the amount leaving the bore hole and do not increase pressure or flow to free stuck drill heads, reamers or piping. Open cutting to retrieve stuck drill heads is not allowed without prior permission from the District Engineer.
- b. The minimum depth shall adhere to the table below for transverse (under non-controlled access, partial controlled access, or limited controlled access roadway) installations and refers to maximum diameter of hole drilled and not the dimension of the carrier or encasement pipe.

<u>Diameter of Drilled Hole (Backream)</u>	<u>Minimum Depth of Cover</u>
2" to 6"	5 feet
>6" to 15"	12 times hole diameter (e.g. 6-inch hole means 6 feet minimum depth)
>15" to 36"	15 feet or greater

- c. Under fully controlled access roadway installations, the minimum depth for transverse crossings shall be 15 feet under any pavement (ramps or thru lanes)
- d. An overbore (backream diameter) shall not be more than 1.5 times the outside diameter of the pipe or encasement under any highway for pipes 12 inches in diameter or less. For pipes with outer diameter larger than 12 inches, the overbore may be no larger than outer diameter of pipe plus 6 inches. An overbore exceeding 1.5 times greater than the outside diameter of the pipe or encasement may be considered if the encroachment agreement includes a statement signed and sealed by a licensed North Carolina Professional Engineer indicating that an overbore in excess of 1.5 times the outside diameter of the pipe or encasement will appropriately arch and no damage will be done to the pavement or sub-grade.
- e. Directional boring is allowed beneath embankment material in naturally occurring soil.

- f. Any parallel installation utilizing the directional boring method shall be made at a minimum depth of three (3') feet (cover) below the ground surface and outside the theoretical 1:1 slope from the existing edge of pavement except where the parallel installation crosses a paved roadway.
- g. All directional bores shall maintain ten (10) feet minimum (clear) distance from the nearest part of any structure, including but not limited to bridges, footings, pipe culverts or box culverts. Directional bores are not allowed beneath bridge footings, culvert wingwall footings, slope protection or retaining walls.
- h. The tip of the drill string shall have a cutter head.
- i. Detection wire shall be installed with non-ferrous material.
- j. HDPE pipe installed by directional boring shall not be connected to existing pipe or fittings for one (1) week from the time of installation to allow tensional stresses to relax.

Aerial clearances

- 82. Vertical clearance of overhead power and communication lines shall meet the National Electrical Safety Code requirements except the minimum vertical clearance shall be 18' for crossings over NCDOT roadways (24' over Fully Controlled Access roadways) and 16' for parallel installations.
- 83. In relation to the bridge, the utility line shall be located with minimum clearances as indicated on the attachment for NCDOT **Required Clearances for Aerial Installations by Encroachment Near Bridge Structures**.

Pavement Detail and Repair

- 84. The paving of this roadway shall be in accordance with the latest version of the NCDOT Standard Specifications, Sections 610, 1012 and 1020. The Contractor shall follow all procedures of the Quality Management System (QMS) for asphalt pavement - Maintenance Version (see <https://connect.ncdot.gov/resources/Materials/MaterialsResources/2018%20QMS%20Asphalt%20Manual.pdf>). The Contractor must adhere to all testing requirements and quality control requirements specified. The Contractor shall contact the NCDOT Division QA Supervisor prior to producing plant mix and make the Supervisor aware that the mix is being produced for a future NCDOT road. Contact the District Engineer to determine the NCDOT Division QA Supervisor. Only NCDOT approved mix designs will be acceptable. A Quality Control Plan shall be submitted (as Directed by the District Engineer) to the District Engineer's Office prior to asphalt production utilizing form QMS-MV1. Failing mixes and/or densities are subject to penalties including monetary payments or removal and replacement. To minimize traffic queuing in construction areas, the possibility of traffic detours may be considered when working on high traffic routes even if traffic control is used. The District Engineer may require traffic detours.

85. When paving beyond utility installation is involved or as directed by the Engineer, a Roadway certification report sealed by a Professional Engineer shall be submitted to the District Engineer's office indicating the following:

- Pavement thickness by type
- Pavement density, core and/or test locations
- Base thickness
- Base density
- Subgrade density

Test frequency and method shall be in conformance with the NCDOT *Materials and Tests Manual*. Test must be performed by a Certified Technician including name and Certification number on report.

86. "Potholing" pavement cores to expose existing utilities shall be made with an 18" diameter keyhole pavement core. Pavement core locations shall not be placed in the wheel path whenever possible. Vacuum excavation shall be utilized to expose underground utilities. Pavement cores shall be repaired within the same working day. The pavement core shall be retained and reused to fill the core hole.

The excavation shall be backfilled and compacted with select material to the bottom of the existing pavement structure or as indicated by the District Engineer. The retained core shall be placed in the hole and secured with a waterproof, mechanical joint. If the pavement core is damaged and cannot be re-used, the core may be replaced with the surface mix, S9.5B. The asphalt patch shall match the thickness of the existing asphalt or four inches, whichever is greater. All materials must be listed on the NCDOT Approved Products List (APL) found at: <https://apps.ncdot.gov/vendor/approvedproducts/>.

87. Open cuts are not permitted on SR 1115 (Buffalo Lake Road) and/or SR 2171 (Orchard Crest Circle).

88. All open cuts (if permitted) on primary routes will require full depth patching with 5.0" of B 25.0 B (ACBC) Asphalt Concrete Base Course, 3.0" of I 19.0 B (ACIC) Asphalt Concrete Intermediate Course and 2.0" of S 9.5 B (ACSC) Asphalt Concrete Surface Course the same day as cut is made. It will also be required to mill the existing pavement surface at a depth of 2.0" and a width of 1.0' on each side of the cut to key in the patch with the existing pavement surface in accordance with the attached detail.

89. All open cuts (if permitted) on secondary routes will require full depth patching with 4.0" of B 25.0 C (ACBC) Asphalt Concrete Base Course and 3.0" of S 9.5 C (ACSC) Asphalt Concrete Surface Course the same day as cut is made. It will also be required to mill the existing pavement surface at a depth of 1.5" and a width of 1.0' on each side of the cut to key in the patch with the existing pavement surface in accordance with the attached detail.

90. Eight inches of ABC will be used as the base. Compaction test shall be performed at the location of every open cut that crosses NCDOT roadways. The owner will be required to have an approved laboratory furnish the District Office a copy of the test results.

91. Pavement cuts shall be repaired the same day the cuts are made unless an asphalt patch cannot be accomplished the same day due to material availability or time restrictions. When the asphalt patch is not feasible, the following apply:
 - a. The pavement cut shall be filled to the surface with ABC stone or Flowable Fill per NCDOT's Standards and Specifications.
 - b. Once the cut is filled, a minimum ¾-inch steel plate shall be placed and pinned to prevent moving. Plates shall be designed large enough to span a minimum of 1-foot on all sides on the pavement cut.
 - c. When flowable fill is used, it shall cure for 24 hours prior to any asphalt material placement. Flowable fill bleed water shall not be present during paving operations. Paving shall not cause damage (shoving, distortion, pumping, etc.) to the flowable fill.
 - d. Install and leave "BUMP" signs according to MUTCD until the steel plate has been removed. Once the flowable fill has cured, remove the steel plate, and mill/fill according to the directions of the District Engineer.
 - e. All pavement cuts must be sealed with NCDOT approved sealant to prevent future pavement separation or cracking.
92. Any pavement damaged because of settlement of the pavement or damaged by equipment used to perform encroachment work, shall be re-surfaced to the satisfaction of the District Engineer. This may include the removal of pavement and a 50' mechanical overlay. All pavement work and pavement markings (temporary and final) are the responsibility of the Encroaching Party.
93. All concrete installed within NCDOT rights of way shall be constructed in accordance with the latest NCDOT **Standard Specifications for Roads and Structures** and **Roadway Standard Drawings** and Amendments or Supplementals thereto. All concrete shall be an approved NCDOT Class B mix. All materials testing results shall be provided to the District Engineer upon completion of the project.
94. All concrete sidewalk installed within NCDOT rights of way shall be constructed in accordance with the latest NCDOT **Standard Specifications for Roads and Structures** and **Roadway Standard Drawings** (Std. Dwg. No. 846.01 and 848.01) and Amendments or Supplementals thereto. All concrete shall be an approved NCDOT Class B mix. All materials testing results shall be provided to the District Engineer upon completion of the project.
95. All ADA compliant curb ramps shall be constructed in accordance with the latest NCDOT **Standard Specifications for Roads and Structures** and **Roadway Standard Drawings** (Std. Dwg. No. 848.06) and Amendments or Supplementals thereto including but not limited to the Alternate Curb Ramp Designs (Curb Ramp Details - Parallel Ramps). All concrete shall be an approved NCDOT Class B mix. All materials testing results shall be provided to the District Engineer upon completion of the project.
96. All 30" curb and gutter within NCDOT rights of way shall be constructed with Class B concrete in accordance with Section 846 of the latest NCDOT **Standard Specifications for Roads and Structures** and **Roadway Standard Drawings** (Std. Dwg. No. 846.01) and Amendment or Supplemental thereto or as directed by the engineer. All concrete testing results shall be provided to the District Engineer's office at time of project completion.

Post Construction

Close out/ Inspection

97. The Encroaching party shall notify the District Engineer’s office within 2 business days after construction is complete. The District Engineer may perform a construction inspection. Any deficiencies may be noted and reported to the encroaching party to make immediate repairs or resolve any issues to restore the right-of-way to a similar condition prior to construction, including pavement, signage, traffic signals, pavement markings, drainage, structures/pipes, or other highway design features.
98. At the discretion of the District Engineer, a final inspection report may be provided to the encroaching party upon satisfactory completion of the work.
99. A written acknowledgement of the completed work by the District Engineer’s office begins the one-year warranty period associated with the performance bond.
- 100. Within ninety (90) days of the completion of the proposed utility installation, an As-Built drawing(s) and an executed Contractor Certification Memo shall be submitted to the District Office (online encroachment database). The As-Built drawing(s) shall depict the horizontal and vertical locations of all utilities and associated appurtenances.**
101. A copy (in PDF format) of the completed ground water analysis shall be given to the District Engineer, including detailed drawings of the “as-built” wells showing location, depth and water level in well.

If further information or assistance is needed in reference to this project, please feel free to call Mr. Lee R. Hines, Jr. (Richie), PE, District Engineer at (910) 364-0601.

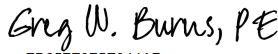
Sincerely,
DocuSigned by:

FB657E975E844A7...
Greg W. Burns, PE
Division Engineer

DS

GWB:ecl

cc: <https://connect.ncdot.gov/site/Permits/Pages/All-Submissions.aspx>

ROUTE 1115

PROJECT

COUNTY OF

HARNETT

RECEIVED

NOV 24 2020

DEPARTMENT OF TRANSPORTATION

RIGHT OF WAY ENCROACHMENT AGREEMENT
FOR NON-UTILITY ENCROACHMENTS ON
PRIMARY AND SECONDARY HIGHWAYS

DIVISION 6-DISTRICT 2

-AND-

KATHRYN WHITE EAGLE,
REPRESENTATIVE FOR ORCHARD 44 Orchard Crest Circle
CREST CIRCLE RESIDENTS Sanford, NC 27332

THIS AGREEMENT, made and entered into this the 1st day of Dec., 20 20, by and between the Department of Transportation, party of the first part; and KATHRYN WHITE EAGLE, REPRESENTATIVE OF THE ORCHARD CREST CIRCLE SUBDIVISION RESIDENTS party of the second part,

WITNESSETH

THAT WHEREAS, the party of the second part desires to encroach on the right of way of the public road designated as Route(s) 1115, HARNETT CO., NC SR 1115, SR 2171, located AT INTERSECTION OF BUFFALO LAKE RD. AND ORCHARD CREST CIRCLE, SANFORD, NC with the construction and/or erection of: A REPLACEMENT SUBDIVISION MONUMENT-STYLE SIGN
installation of a new breakaway sign inside the existing island to replace old sign that was damaged by a car

WHEREAS, it is to the material advantage of the party of the second part to effect this encroachment, and the party of the first part in the exercise of authority conferred upon it by statute, is willing to permit the encroachment within the limits of the right of way as indicated, subject to the conditions of this agreement;

NOW, THEREFORE, IT IS AGREED that the party of the first part hereby grants to the party of the second part the right and privilege to make this encroachment as shown on attached plan sheet(s), specifications and special provisions which are made a part hereof upon the following conditions, to wit:

That the said party of the second part binds and obligates himself to install and maintain the encroaching facility in such safe and proper condition that it will not interfere with or endanger travel upon said highway, nor obstruct nor interfere with the proper maintenance thereof, to reimburse the party of the first part for the cost incurred for any repairs or maintenance to its roadways and structures necessary due to the installation and existence of the facilities of the party of the second part, and if at any time the party of the first part shall require the removal of or changes in the location of the said facilities, that the said party of the second part binds himself, his successors and assigns, to promptly remove or alter the said facilities, in order to conform to the said requirement, without any cost to the party of the first part.

That the party of the second part agrees to provide during construction and any subsequent maintenance proper signs, signal lights, flagmen and other warning devices for the protection of traffic in conformance with the latest Manual on Uniform Traffic Control Devices for Streets and Highways and Amendments or Supplements thereto. Information as to the above rules and regulations may be obtained from the Division Engineer of the party of the first part.

That the party of the second part hereby agrees to indemnify and save harmless the party of the first part from all damages and claims for damage that may arise by reason of the installation and maintenance of this encroachment.

It is clearly understood by the party of the second part that the party of the first part will assume no responsibility for any damage that may be caused to such facilities, within the highway rights of way limits, in carrying out its construction and maintenance operations.

That the party of the second part agrees to restore all areas disturbed during installation and maintenance to the satisfaction of the Division Engineer of the party of the first part. The party of the second part agrees to exercise every reasonable precaution during construction and maintenance to prevent eroding of soil; silting or pollution of rivers, streams, lakes, reservoirs, other water impoundments, ground surfaces or other property; or pollution of the air. There shall be compliance with applicable rules and regulations of the North Carolina Division of Environmental Management, North Carolina Sedimentation Control Commission, and with ordinances and regulations of various counties, municipalities and other official agencies relating to pollution prevention and control. When any installation or maintenance operation disturbs the ground surface and existing ground cover, the party of the second part agrees to remove and replace the sod or otherwise reestablish the grass cover to meet the satisfaction of the Division Engineer of the party of the first part.

That the party of the second part agrees to assume the actual cost of any inspection of the work considered to be necessary by the Division Engineer of the party of the first part.

That the party of the second part agrees to have available at the encroaching site, at all times during construction, a copy of this agreement showing evidence of approval by the party of the first part. The party of the first part reserves the right to stop all work unless evidence of approval can be shown.

Provided the work contained in this agreement is being performed on a completed highway open to traffic; the party of the second part agrees to give written notice to the Division Engineer of the party of the first part when all work contained herein has been completed. Unless specifically requested by the party of the first part, written notice of completion of work on highway projects under construction will not be required.

That in the case of noncompliance with the terms of this agreement by the party of the second part, the party of the first part reserves the right to stop all work until the facility has been brought into compliance or removed from the right of way at no cost to the party of the first part.

That it is agreed by both parties that this agreement shall become void if actual construction of the work contemplated herein is not begun within one (1) year from the date of authorization by the party of the first part unless written waiver is secured by the party of the second part from the party of the first part.

R/W (161A) : Party of the Second Part certifies that this agreement is true and accurate copy of the form R/W (161A) incorporating all revisions to date.

IN WITNESS WHEREOF, each of the parties to this agreement has caused the same to be executed the day and year first above written.

DEPARTMENT OF TRANSPORTATION
Signed by: Greg W. Burns, PE ^{DS} Ell
By: Greg W. Burns, PE
~~Public Use of Right of Way~~
Division Engineer

ATTEST OR WITNESS:

Kathy Karstaedt
294 King Rd Monroeville NC 27559
Kathy Karstaedt

Kathryn White Eagle
94 Orchard Crest Cir, Sanford, NC 27332
KATHRYN WHITE EAGLE
Second Party

INSTRUCTIONS

When the applicant is a corporation or a municipality, this agreement must have the corporate seal and be attested by the corporation secretary or by the empowered city official, unless a waiver of corporate seal and attestation by the secretary or by the empowered City official is on file in the Raleigh office of the Manager of Right of Way. In the space provided in this agreement for execution, the name of the corporation or municipality shall be typed above the name, and title of all persons signing the agreement should be typed directly below their signature.

When the applicant is not a corporation, then his signature must be witnessed by one person. The address should be included in this agreement and the names of all persons signing the agreement should be typed directly below their signature.

This agreement must be accompanied, in the form of an attachment, by plans or drawings showing the following applicable information:

1. All roadways and ramps.
2. Right of way lines and where applicable, the control of access lines.
3. Location of the proposed encroachment.
4. Length and type of encroachment.
5. Location by highway survey station number. If station number cannot be obtained, location should be shown by distance from some identifiable point, such as a bridge, road, intersection, etc. (To assist in preparation of the encroachment plan, the Department's roadway plans may be seen at the various Highway Division Offices, or at the Raleigh office.)
6. Drainage structures or bridges if affected by encroachment.
7. Typical section indicating the pavement design and width, and the slopes, widths and details for either a curb and gutter or a shoulder and ditch section, whichever is applicable.
8. Horizontal alignment indicating general curve data, where applicable.
9. Vertical alignment indicated by percent grade, P.I. station and vertical curve length, where applicable.
10. Amount of material to be removed and/or placed on NCDOT right of way, if applicable.
11. Cross-sections of all grading operations, indicating slope ratio and reference by station where applicable.
12. All pertinent drainage structures proposed. Include all hydraulic data, pipe sizes, structure details and other related information.
13. Erosion and sediment control.
14. Any special provisions or specifications as to the performance of the work or the method of construction that may be required by the Department must be shown on a separate sheet attached to encroachment agreement provided that such information cannot be shown on plans or drawings.
15. The Department's Division Engineer should be given notice by the applicant prior to actual starting of installation included in this agreement.
16. Method of handling traffic during construction where applicable.
17. Scale of plans, north arrow, etc.

WORKFORCE SAFETY PLAN

FOR ENCROACHMENT ACTIVITIES: COVID-19

EFFORTS THE N.C. TRANSPORTATION INDUSTRY IS TAKING TO STOP THE SPREAD OF COVID-19

The North Carolina Department of Transportation (NCDOT) and their partners expect all parties involved in the delivery of transportation projects to abide by the guidelines issued from the Centers for Disease Control and Prevention (CDC) and the North Carolina Department of Health and Human Services (NCDHHS).

Response to COVID-19 is rapidly evolving; new information and guidelines may be issued from the CDC, NCDHHS, or other state or federal agencies. NCDOT and their partners should review the current CDC and NCDHHS guidance, including the resources listed at the end of this document, for up-to-date information on how to respond to COVID-19. Additional guidelines may be issued by state or federal agencies that should be followed in addition to the guidance included in this document.

Though certain Americans with Disabilities Act (ADA) requirements have been relaxed in response to the pandemic, employers must still maintain all information about employee illness as a confidential medical record in compliance with the ADA. If an employee is suspected of having or tests positive for COVID-19, it is essential that management keep the identity of the employee and details related to the employee's health confidential.

Below are precautions required by NCDOT and from encroaching parties and their contractors performing construction within NCDOT Rights of Way. The term employee refers to any person on a job site within NCDOT right of way for the purpose of constructing or inspecting the work related to construction of a facility under an approved encroachment agreement and where that employee may or may not be under employment by or under contract to NCDOT.

EMPLOYEE WELLNESS

- If an employee has not yet reported to work and develops any COVID-19 symptoms (i.e. fever, coughing, or shortness of breath) — STAY HOME and immediately:
 - Call a health care provider
 - Self-Isolate
 - Communicate with your supervisor
 - Remain calm and follow all instructions from your health care provider
- Employees who appear to have acute respiratory illness symptoms (i.e. cough, shortness of breath) upon arrival to work, or become sick during the day, should be separated from others and sent home immediately. The potentially affected employees should immediately follow the steps outlined above, which includes immediately contacting a health care provider.
- Should an employee show symptoms of acute respiratory illness or be diagnosed with COVID-19, all other employees who have worked in close proximity to the affected employee during the last 14

days and all encroachment points of contact indicated at the end of this plan should be notified of potential exposure to the disease without identifying the affected employee.

- Consideration should be given to employees at “High Risk” of severe illness from COVID-19, who, per NCDHHS, include employees:
 - Over 65 years of age, **OR**
 - With underlying health conditions including heart disease, lung disease, or diabetes, **OR**
 - With weakened immune system
- “High Risk” Employees should be given the opportunity to discuss alternate work arrangements/duties with their employer or take leave according to their company policies.
- For guidance on confirmed positive tests for COVID-19, refer to the most recent version of the “COVID-19 Guidance for Employees on Encroachment Job Sites within NCDOT Right of Way” located on last page of this plan.

PERSONAL HYGIENE

- Clean hands often by washing with soap and water for 20 seconds. If soap and water are not available and hands are not visibly dirty, an alcohol-based hand sanitizer that contains 60%-95% alcohol may be used.
- Avoid touching your eyes, nose, mouth, or other parts of your face.
- Do not breathe, cough, or sneeze on another person or into the open air. Employees should cover their noses and mouth with a tissue when coughing or sneezing (or an elbow or shoulder if no tissue is available).
- A facemask for covering nose and mouth is encouraged on the job site.
- Appropriate gloves are encouraged while performing functions of the job.

CLEANING/DISINFECTING

- Wash stations and/or hand sanitizer are encouraged on each project site.
- Appropriate cleaning staff should clean frequently touched surfaces and objects with disinfectants at a minimum of once per day.
 - Office/buildings: door knobs, light switches, phones, computers/keyboards, copy machines, elevator buttons, toilets, faucets, sinks, countertops, paper towel dispensers, desktops, handrails, folders, vending machines, counters, tables, cabinets/knobs, etc.
 - Shop Yard/Jobsite: vehicle/equipment door handles, keys, gear shifts, steering wheel/operator controls and levers, fuel pump dispensers, touch points on machinery, etc.
 - Electronic equipment: cell phones, computers, keyboards, etc.
- Appropriate cleaning staff should sanitize/disinfect facilities and work areas after persons suspected/confirmed to have COVID-19 have been in the facility or work area.

- It is recommended to close off access to areas used by the ill persons and wait as long as practical, 24 hours if possible, before beginning cleaning and disinfection to minimize potential for exposure to respiratory droplets. Open outside doors and windows to increase air circulation in the area if possible.
- Appropriate cleaning staff should clean and disinfect all areas used by the ill persons, focusing especially on frequently touched surfaces.

GENERAL

- Increase communication measures between all parties regarding schedule, daily activities, etc. to reduce/minimize worker exposure in accordance with but not limited to the requirements below.
- Minimize on-site personnel such as subcontractors, work crews, QC personnel, and inspection staff to those required for that day's activities. If work is postponed or cancelled, immediately notify appropriate parties.
- Practice "Social Distancing" whenever feasible. Social Distancing is designed to limit the spread of a disease by reducing the opportunities for close contact between people. All personnel have the responsibility to remind each other to stay 6 feet or more apart. Examples of Social Distancing include:
 - Reducing face-to-face exposure by using conference calls and video conferencing
 - If an in-person meeting is absolutely required and cannot be rescheduled or attended remotely, the meeting is limited to a maximum of 10 people while maintaining Social Distancing of 6 feet or more.
 - Avoiding unnecessary travel
- Do not congregate at lunch or breaks. Bringing your lunch is encouraged.
- No communal coolers or drink stations are allowed. Supervisors should confirm with employees prior to beginning work for appropriate hydration and nutrition availability to employees for the duration of the employee's shift and without direct contact with others on the job site.
- First line of communication should be by phone, rather than in-person.
- Do not shake hands.
- Do not share iPads, tablets, pens, or clipboards for signing or any other purpose. Take pictures as proof of attendance at meetings.
- Sharing of Personal Protective Equipment (PPE) is strictly prohibited.
- Vehicles, equipment, and tools
 - Limit the number of people riding in a vehicle together.
 - Wipe down and disinfect vehicles after each trip.
 - As much as possible, do not share tools or equipment. If a tool or piece of equipment must be shared, the parts of it that are touched should be sanitized between uses.

RETURN TO WORK

- The following criteria must be followed for an employee who is tested for Covid-19, or asked to self-quarantine by health officials, or has contact with another employee with a positive test result to return to work:
 - at least a 14-day quarantine; **OR**
 - release by a health care provider.
- In accordance with CDC guidance, the following criteria must be followed for an employee with a positive test result to return to work:
 - at least 14 days from positive test notification; **AND**
 - at least 3 days (72 hours) have passed since recovery defined as resolution of fever without the use of fever-reducing medications and improvement in respiratory symptoms (e.g., cough, shortness of breath); **AND**
 - at least 7 days have passed since symptoms first appeared.

NCDOT may require certification of fitness to work from a health care provider.

ADDITIONAL RESOURCES

NCDOT and their partners should review the CDC and NCDHHS resources listed below for up-to-date information on how to respond to COVID-19. Additional guidelines may be issued by state or federal agencies that should be followed in addition to the guidelines included in this document.

- NCDHHS COVID-19 Resources:
 - <https://www.ncdhhs.gov/divisions/public-health/coronavirus-disease-2019-covid-19-response-north-carolina>
- NCOSHR Communicable Disease Emergency Policy
 - <https://oshr.nc.gov/policies-forms/workplace-wellness/communicable-disease-emergency>
- OSHA Guidance on Preparing Workplaces for COVID-19
 - <https://www.osha.gov/Publications/OSHA3990.pdf>
- CDC COVID-19 Resources:
 - <https://www.cdc.gov/coronavirus/2019-ncov/index.html>

AGREEMENT

The encroaching party shall adhere to the requirements of this plan in order to continue work under their approved encroachment agreement. Violations to this plan could result in the violating entity not being allowed to continue work or all work ceasing as determined by the NCDOT District Engineer or Resident Engineer.

PROJECT POINTS OF CONTACT

DocuSigned by: **NCDOT**
Name: Earl C. Locklear
FB657F975F844A7...
Phone #: 910-364-0601

Encroaching Party (Primary Contact)
Name: Kathryn White Eagle
Phone #: (919) 451-0168

**Primary Contractor to Encroaching Party
(Point of Contact)**
Name: M. Brandon Mangum
Phone #: (919) 306-3802

COVID-19 Guidance for Employees on Encroachment Job sites within NCDOT Right of Way			
CONTACT GROUP			
Relationship to Confirmed POSITIVE Test	What YOU Should Do	What your CREW Should Do <i>Exposure within 6' and longer than 10 minutes</i>	What PROJECT SITE Personnel Should Do <i>No exposure within 6' and longer than 10 minutes</i>
Employee	<p>Notify your supervisor</p> <p>Self-quarantine for 14 days</p>	<p>Advise of POSITIVE test without identifying the affected employee*</p> <p>Directly exposed crew self-quarantine for 14 days</p> <p>Continue hygiene & disinfecting measures</p>	<p>Advise of POSITIVE test without identifying the affected employee*</p> <p>Site personnel without direct contact may continue onsite work or follow their company policy</p> <p>Continue hygiene & disinfecting measures</p>
Direct Contact <i>Interaction with an infected person within 6' and longer than 10 minutes</i>	<p>Self-quarantine for 14 days</p>	<p>Advise of POSITIVE test without identifying the affected employee*</p> <p>Crew may continue onsite work or follow their company policy</p> <p>Continue hygiene & disinfecting measures</p>	<p>Advise of POSITIVE test *</p> <p>Continue hygiene & disinfecting measures</p>
Secondary Contact	<p>You may continue onsite work or follow your company policy</p> <p>Continue hygiene & disinfecting measures</p>	<p>Continue hygiene & disinfecting measures</p>	<p>Continue hygiene & disinfecting measures</p>
Two or more Persons Removed from Contact	<p>Continue hygiene & disinfecting measures</p>	<p>Continue hygiene & disinfecting measures</p>	<p>Continue hygiene & disinfecting measures</p>
*Notification Protocol <i>(Comply with HIPAA & ADA confidentiality requirements)</i>	<p>NCDOT District Engineer/Resident Engineer notifies Encroaching Party's primary point of contact and Contractor Point of Contact, CDC and, if Resident Engineer has oversight for the job site, FHWA any Consultant Firms working for NCDOT</p> <p>Encroaching party representative notifies other Contractors, Sub-Contractors and Suppliers with exposed Employees</p> <p>Encroaching party representative or Contractor point of contact notifies appropriate NCDOT District Engineer or Resident Engineer and all other Contractors, Sub-Contractors and Suppliers with exposed Employees</p> <p>NCDOT notifies CDC, and as appropriate, FHWA and any Consultant Firms working for NCDOT</p>		

TRAFFIC CONTROL AND WORK ZONE SAFETY

The Contractor shall maintain traffic during construction and provide, install, and maintain all traffic control devices in accordance with these project guidelines, the Project Special Provisions, North Carolina Department of Transportation Standard Specifications for Roads and Structures 2018, and the current edition of the Manual of Uniform Traffic Control Devices (MUTCD).

The Contractor shall utilize complete and proper traffic controls and traffic control devices during all operations. All traffic control and traffic control devices required for any operation shall be functional and in place prior to the commencement of that operation. Signs for temporary operations shall be removed during periods of inactivity. The Contractor is required to leave the project in a manner that will be safe to the traveling public and which will not impede motorists.

Traffic movements through lane closures on roads with two way traffic shall be controlled by flaggers stationed at each end of the work zone. In situations where sight distance is limited, the Contractor shall provide additional means of controlling traffic, including, but not limited to, two-way radios, pilot vehicles, or additional flaggers. Flaggers shall be competent personnel, adequately trained in flagging procedures, and furnished with proper safety devices and equipment, including, but not limited to, safety vests and stop/slow paddles.

All personnel when working in traffic areas or areas in close proximity to traffic shall wear an approved safety vest, or shirt or jacket which meets the color requirements of the Manual of Uniform Traffic Control Devices (MUTCD).

The Contractor shall comply with all applicable Federal, State, and local laws, ordinances, and regulations governing safety, health, and sanitation, and shall provide all safeguards, safety devices, and protective equipment, and shall take any other needed actions, on his own responsibility that are reasonably necessary to protect the life and health of employees on the job and the safety of the public, and to protect property in connection with the performance of the work covered by the contract.

Failure to comply with any of the requirements for safety and traffic control of this contract shall result in suspension of work as provided in subarticle 108-7(2) of the Standard Specifications.

SPECIFICATIONS FOR EROSION CONTROL

The Contractor shall seed all disturbed areas as directed by the Engineer, in accordance with Section 1660 of the Standard Specifications. Seeding and mulching shall immediately follow shoulder construction operations and in no case shall shoulder construction operations exceed seeding and mulching operations by more than two weeks without written permission of the Engineer. Failure to meet this requirement shall be cause to cease all operations until it can be met.

Seeding and Mulching: (East)

The kinds of seed and fertilizer, and the rates of application of seed, fertilizer, and limestone, shall be as stated below. During periods of overlapping dates, the kind of seed to be used shall be determined by the Engineer. All rates are in pounds per acre.

The kinds of seed and fertilizer, and the rates of application of seed, fertilizer, and limestone, shall be as stated below. During periods of overlapping dates, the kind of seed to be used shall be determined. All rates are in pounds per acre.

All Roadway Areas

March 1 - August 31

50#	Tall Fescue
10#	Centipede
25#	Bermudagrass (hulled)
500#	Fertilizer
4000#	Limestone

September 1 - February 28

50#	Tall Fescue
10#	Centipede
35#	Bermudagrass (unhulled)
500#	Fertilizer
4000#	Limestone

Waste and Borrow Locations

March 1 - August 31

75#	Tall Fescue
25#	Bermudagrass (hulled)
500#	Fertilizer
4000#	Limestone

September 1 - February 28

75#	Tall Fescue
35#	Bermudagrass (unhulled)
500#	Fertilizer
4000#	Limestone

Note: 50# of Bahiagrass may be substituted for either Centipede or Bermudagrass only upon Engineer's request.

Approved Tall Fescue Cultivars

2 nd Millennium	Duster	Magellan	Rendition
Avenger	Endeavor	Masterpiece	Scorpion
Barlexas	Escalade	Matador	Shelby
Barlexas II	Falcon II, III, IV & V	Matador GT	Signia
Barrera	Fidelity	Millennium	Silverstar
Barrington	Finesse II	Montauk	Southern Choice II
Biltmore	Firebird	Mustang 3	Stetson
Bingo	Focus	Olympic Gold	Tarheel
Bravo	Grande II	Padre	Titan Ltd
Cayenne	Greenkeeper	Paraiso	Titanium
Chapel Hill	Greystone	Picasso	Tomahawk
Chesapeake	Inferno	Piedmont	Tacer
Constitution	Justice	Pure Gold	Trooper
Chipper	Jaguar 3	Prospect	Turbo
Coronado	Kalahari	Quest	Ultimate
Coyote	Kentucky 31	Rebel Exeda	Watchdog
Davinci	Kitty Hawk	Rebel Sentry	Wolfpack
Dynasty	Kitty Hawk 2000	Regiment II	
Dominion	Lexington	Rembrandt	

On cut and fill slopes 2:1 or steeper Centipede shall be applied at the rate of 5 pounds per acre and add 20# of Sericea Lespedeza from January 1 - December 31.

Fertilizer shall be 10-20-20 analysis. A different analysis of fertilizer may be used provided the 1-2-2 ratio is maintained and the rate of application adjusted to provide the same amount of plant food as a 10-20-20 analysis and as directed.

All areas seeded and mulched shall be tacked with asphalt. Crimping of straw in lieu of asphalt tack shall not be allowed on this project.

CRIMPING STRAW MULCH

Crimping shall be required on this project adjacent to any section of roadway where traffic is to be maintained or allowed during construction. In areas within six feet of the edge of pavement, straw is to be applied and then crimped. After the crimping operation is complete, an additional application of straw shall be applied and immediately tacked with a sufficient amount of undiluted emulsified asphalt.

Straw mulch shall be of sufficient length and quality to withstand the crimping operation.

Crimping equipment including power source shall be subject to the approval of the Engineer providing that maximum spacing of crimper blades shall not exceed 8".

Within seven (7) calendar days to fourteen (14) calendar days of completion of any phase of grading, all disturbed areas shall be planted or otherwise provided with temporary or permanent ground cover, devices, or structures sufficient to restrain erosion. The Erosion and Sediment Control plan will identify the areas that require seven (7) and/or fourteen (14) calendar day ground stabilization. The Contractor is herein advised to follow all current regulations set forth by the North Carolina Department of Environment and Natural Resources (NCDENR) Division of Water Quality (DWQ) as defined in the *General Stormwater Permit for Construction Activities NCG-01000*.

Attachment 1
Clear Zone Table from Roadside Design Guide

Table 3.1 (Cont'd)

[U.S. Customary Units]

DESIGN SPEED	DESIGN ADT	FORESLOPES			BACKSLOPES		
		1V:6H or flatter	1V:5H TO 1V:4H	1V:3H	1V:3H	1V:5H TO 1V:4H	1V:6H or flatter
40 mph or less	UNDER 750	7 - 10	7 - 10	**	7 - 10	7 - 10	7 - 10
	750 - 1500	10 - 12	12 - 14	**	10 - 12	10 - 12	10 - 12
	1500 - 6000	12 - 14	14 - 16	**	12 - 14	12 - 14	12 - 14
	OVER 6000	14 - 16	16 - 18	**	14 - 16	14 - 16	14 - 16
45-50 mph	UNDER 750	10 - 12	12 - 14	**	8 - 10	8 - 10	10 - 12
	750 - 1500	14 - 16	16 - 20	**	10 - 12	12 - 14	14 - 16
	1500 - 6000	16 - 18	20 - 26	**	12 - 14	14 - 16	16 - 18
	OVER 6000	20 - 22	24 - 28	**	14 - 16	18 - 20	20 - 22
55 mph	UNDER 750	12 - 14	14 - 18	**	8 - 10	10 - 12	10 - 12
	750 - 1500	16 - 18	20 - 24	**	10 - 12	14 - 16	16 - 18
	1500 - 6000	20 - 22	24 - 30	**	14 - 16	16 - 18	20 - 22
	OVER 6000	22 - 24	26 - 32*	**	16 - 18	20 - 22	22 - 24
60 mph	UNDER 750	16 - 18	20 - 24	**	10 - 12	12 - 14	14 - 16
	750 - 1500	20 - 24	26 - 32*	**	12 - 14	16 - 18	20 - 22
	1500 - 6000	26 - 30	32 - 40*	**	14 - 18	18 - 22	24 - 26
	OVER 6000	30 - 32*	36 - 44*	**	20 - 22	24 - 26	26 - 28
65-70 mph	UNDER 750	18 - 20	20 - 26	**	10 - 12	14 - 16	14 - 16
	750 - 1500	24 - 26	28 - 36*	**	12 - 16	18 - 20	20 - 22
	1500 - 6000	28 - 32*	34 - 42*	**	16 - 20	22 - 24	26 - 28
	OVER 6000	30 - 34*	38 - 46*	**	22 - 24	26 - 30	28 - 30

* Where a site specific investigation indicates a high probability of continuing crashes, or such occurrences are indicated by crash history, the designer may provide clear-zone distances greater than the clear-zone shown on Table 3.1. Clear zones may be limited to 30 ft for practicality and to provide a consistent roadway template if previous experience with similar projects or designs indicates satisfactory performance.

** Since recovery is less likely on the unshielded, traversable 1V:3H slopes, fixed objects should not be present in the vicinity of the toe of these slopes. Recovery of high-speed vehicle that encroach beyond the edge of the shoulder may be expected to occur beyond the toe of slope. Determination of the width of the recovery area at the toe of slope should take into consideration right-of-way availability, environmental concerns, economic factors, safety needs, and crash histories. Also, the distance between the edge of the through traveled lane and the beginning of the 1V:3H slope should influence the recovery area provided at the toe of slope. While the application may be limited by several factors, the foreslope parameters which may enter into determining a maximum desirable recovery area are illustrated in Figure 3.2 (see Roadside Design Guide).

Table copied from AASHTO Roadside Design Guide (3rd Edition) 2006

**North Carolina Department of Transportation
Subdivision Road Construct, Driveway Access, and Encroachment Installation
Contractor Certification Memo**

(Date)

(District Engineer Name & Address)

RE: CONSTRUCTION CERTIFICATION

County: _____

Driveway Permit #: _____

and/or Subdivision I.D. #: _____

and/or Encroachment #: _____

Recording Information (if applicable): _____

Route(s) and/or Street(s): _____

Project Name/Phase/Description: _____

I, _____, have reviewed the construction within the right-of-way and/or easements required under subject project(s) for the above development and in accordance with the design drawings approved by the North Carolina Department of Transportation (NCDOT) on the following dates:

Driveway Permit #: _____ Date: _____

and/or Subdivision I.D. #: _____ Date: _____

and/or Encroachment #: _____ Date: _____

My inspection and attached testing report(s) and/or supporting documentation indicate the construction within the right-of-way and/or easements have been constructed in accordance with the standards established by current NCDOT Standard Specifications for Roads and Structures, and with the approved plans.

Name: _____

NC PE #: _____

Signature: _____



SEAL

Received by NCDOT: _____

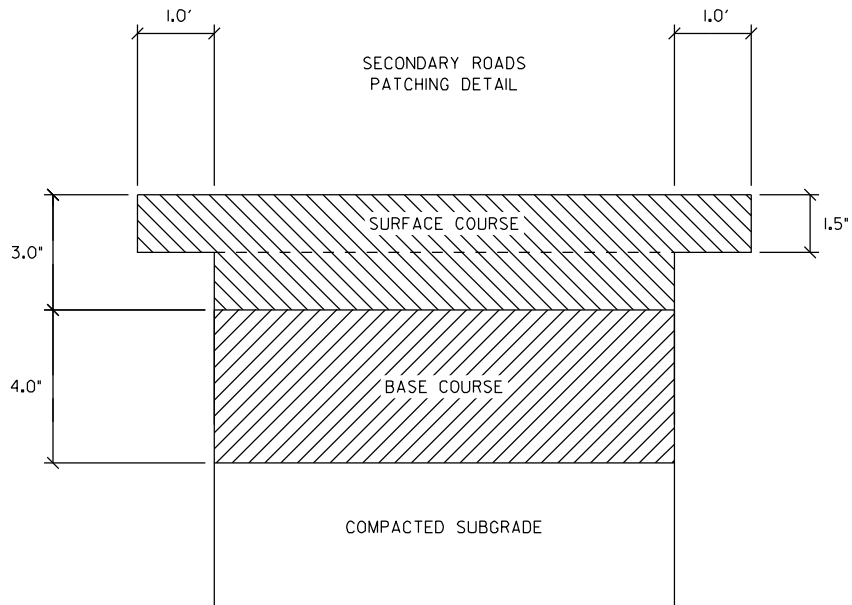

PAVEMENT SCHEDULE

(MILLING REQUIRED ONE FOOT AT DEPTH OF 1.5"
ON EACH SIDE OF PAVEMENT CUT)

3.0' S 9.5 C

4.0' B 25.0 C

DRAWING IS NOT TO SCALE

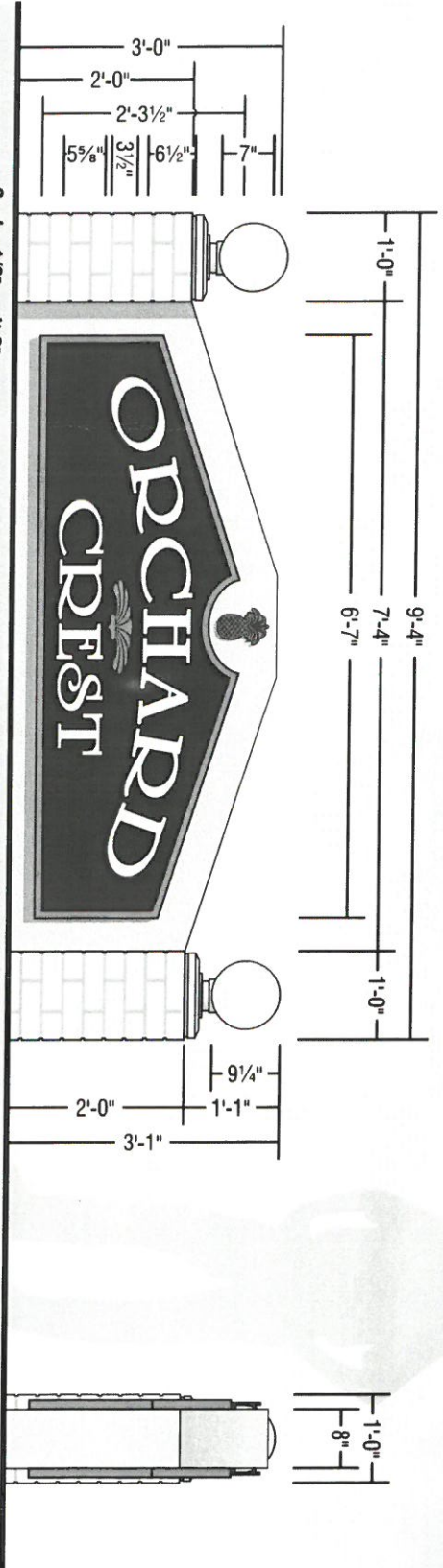

Scale: 1/2" = 1'-0"

End View
(Column Removed)

(1) D/F Non-lighted Monument Sign constructed of Aluminum with Brick Veneer. Main Body Background constructed Aluminum with Textcote finish. Columns of Aluminum with Brick Veneer. Decorative Spheres and Accents on Column of Aluminum. Sign Panels constructed of Aluminum (3/4" deep) with 1" face x 1/2" deep Raised Border. "Orchard Crest" Text and Symbol of .250 Plate Aluminum installed with 1/2" spacers. Pineapple Logo of .250 Plate Aluminum installed to Main Body Background with 1/2" spacers.

D/F Monument Sign installed onto Existing Leveling Pad with median via non-corrosive fasteners.

- Columns with Brick Veneer: painted to match SW 6105 Divine White (satin finish)
- Column Decorative Accents & Spheres: painted to match SW 6105 Divine White (satin finish)
- Main Body Background: painted to match SW 6105 Divine White (Textcote finish)
- Sign Panels Raised Border: painted MP26048 Golden Shadow Metallic (gloss finish)
- Sign Panels Background: painted to match MP15967 Colonial Red (satin finish)
- "Orchard Crest" Letters: painted to match SW 6105 Divine White (satin finish)
- Pineapple & Palm Leaf Logos: painted to match MP15967 Colonial Red (satin) & MP26048 Golden Shadow Metallic (gloss)

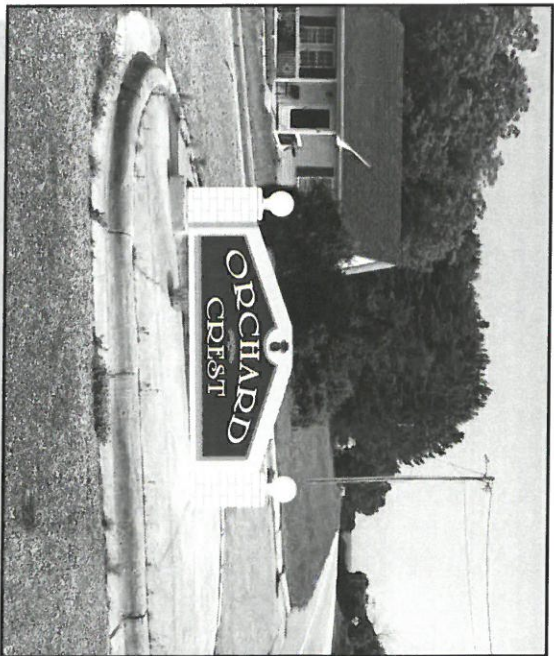

44 Orchard Crest Circle, Sanford, NC

D/F Non-lighted Monument Sign

CAPITAL SIGN SOLUTIONS

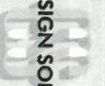

5800 McHines Place, Suite 110

Raleigh, NC 27616

919.789.1452

www.capitalsignsolutions.com

© Copyright 2020 All designs and drawings are the sole property of Capital Sign Solutions, and may not be reproduced, published, changed or used in any way without written permission and consent. In addition, all ideas, contents of proposals, and all specifications of any project entered into with Capital Sign Solutions are all rights reserved.

Client:

ORCHARD CREST

Filename:

Orchard Crest Monument Sign v2

Date:

06-25-20

Designer:

HH

Drawing No:

H-QT14415-1

Scale:

As Noted

Revision 1:	09/21/20
Revision 2:	
Revision 3:	
Revision 4:	
Revision 5:	
Revision 6:	

By signing below I confirm I have reviewed this proposal carefully (INCLUDING ALL NOTES) found it to be correct, & approve this project.

Customer Signature

Date

PG. (1) of (1)

REV.	DESCRIPTION	DATE	BY
A	INITIAL RELEASE	9/11/22	SM
B	UPDATED TO MATCH ENGINEERING	9/21/2022	SM

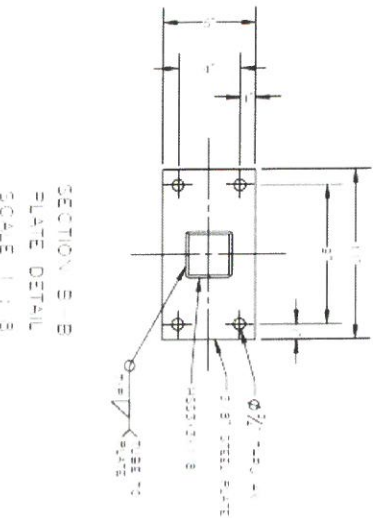
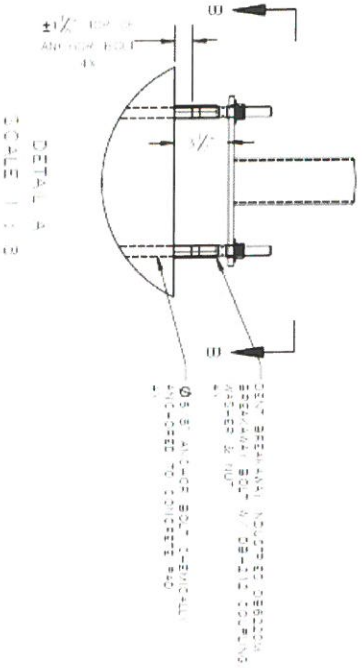
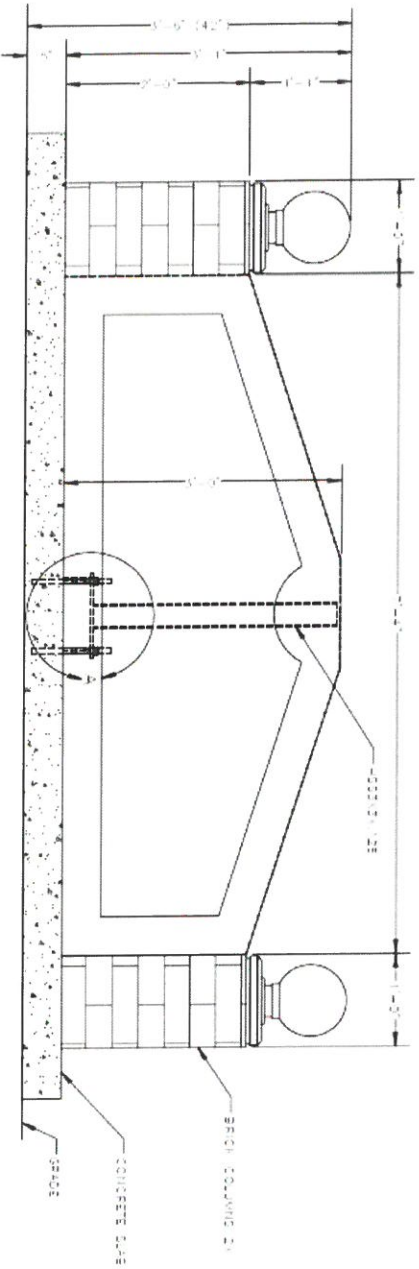

UNAPPROVED: THESE ENGINEERING DRAWINGS SHOULD BE USED AS A GUIDE ONLY.

CAPITAL SIGN SOLUTIONS
 4411 CHURCH AVENUE, SUITE 100
 SAN FORD, NC 28773
 (813) 888-8888

CLIENT: ORCHARD CREST

PROJECT: 44 ORCHARD CIRCLE
 SANFORD, NC

DATE: 09/11/2022

SCALE: 1 OF 1

NEVILLE ENGINEERING
 Consulting Engineer
 213 RIVER BIRCH LN
 CHAPEL HILL, NORTH CAROLINA 27514
 (919) 942-5229 Cell: (919) 740-3427
 neveng@aol.com

JOB: Overhead Crane
 SHEET NO: 1 OF 3
 CALCULATED BY: N DATE: 15 Sept 20
 CHECKED BY: _____ DATE: _____
 SCALE: _____

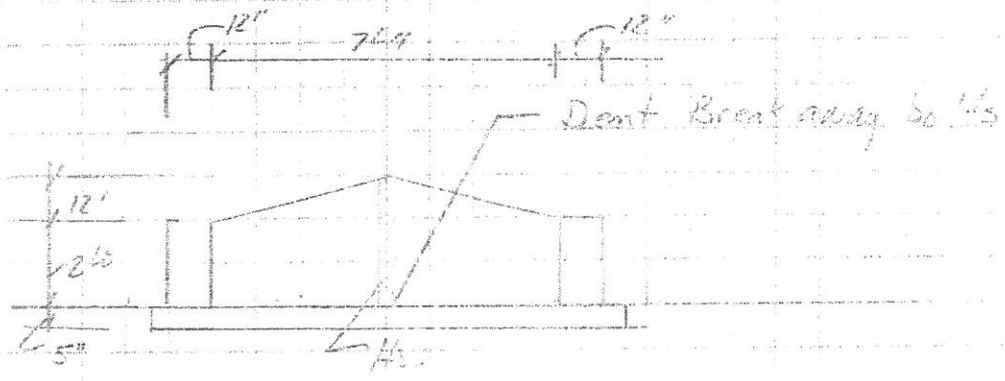

Somerset, NC
 Design 10 m/s speed -
 Unit - 115 mph
 Vmax - 50 mph

$F = 0.00176 (115)^2 \times 1.4 \times 1.4 = 1.8 \times 10^4$
 $F = 1.8 \times 10^4 \times 1.4 = 2.5 \times 10^4$
 $M = 1.8 \times 10^4 \times 1.4 \times 2.33 = 4.2 \times 10^4$
 $HSS 3 \times 3 \times .125 \quad S = 1.19 \text{ ft}$

From Dent Bolt
 $X \times Z = 37.733 \times 1.15 = 32.9$

For 1 post 50 mph
 For 4 bolt base
 Allowable $X \times Z = 97.88 \times 4 = 391.52 > 32.9$
 For .125" Bolt

Momentum = $.217 \text{ ft}^2$
 Slab $5" \times 2' \times 7.43$
 $M = .15 \times 1/2 \times 217.33 = 91$
 $M = 91 \times 1 = 91 > 2.277 \text{ OK}$

use HSS 3x3x.125 set w/ 4 $5/8"$ Dent Breakaway
 Bolts set in $5" \times 24" \times 7.4"$ slab

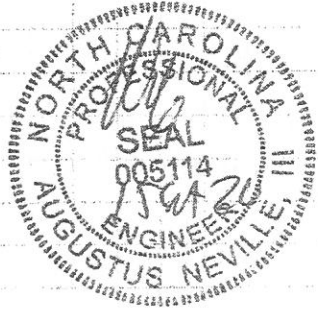

NEVILLE ENGINEERING
 Consulting Engineer
 213 RIVER BIRCH LN
 CHAPEL HILL, NORTH CAROLINA 27514
 (919) 942-5229 Cell: (919) 740-3427
 neveng@aol.com

ON Ordnance Cont. S. 12
 SHEETING 2 OF 2
 CALCULATED BY AN DATE 11/25/20
 CHECKED BY _____ DATE _____
 SCALE _____

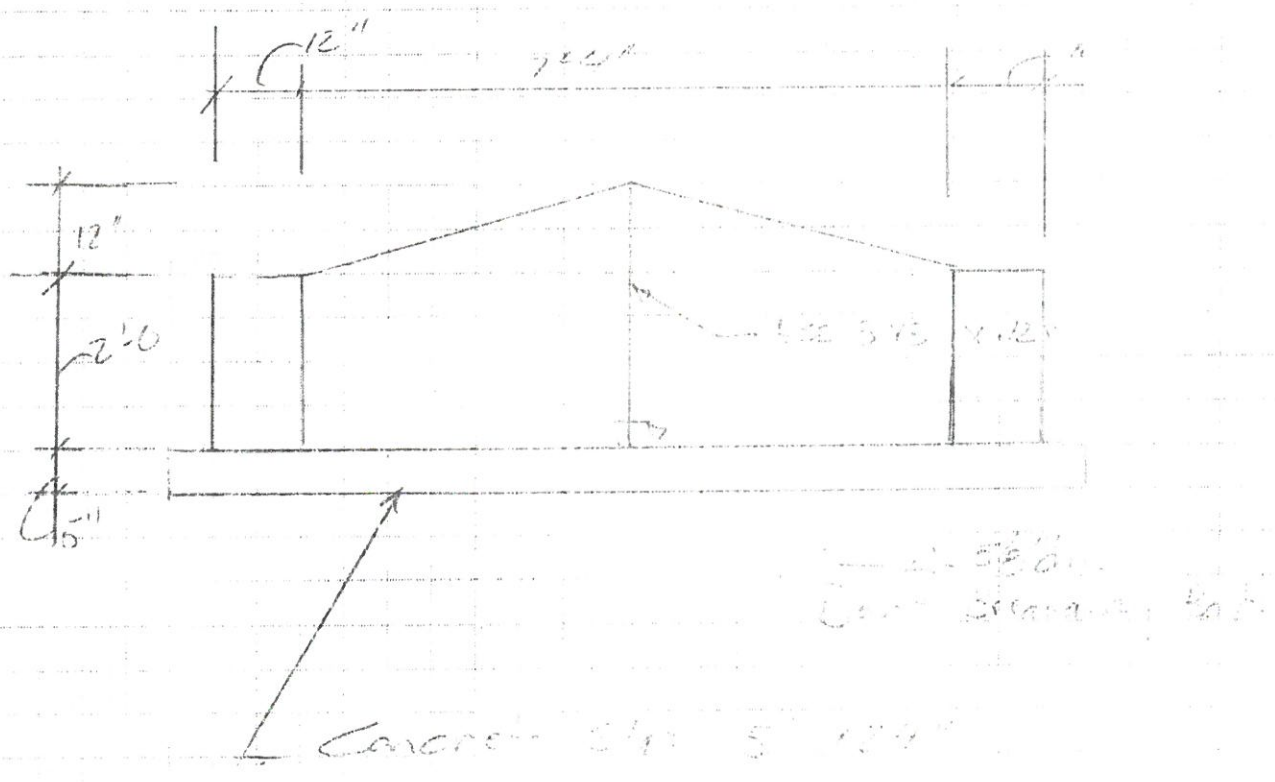

Carload 110
 Design Wind Speed
 Wall = 115 mph
 Wind = 90 mph

Concrete - 3000 psi
 Structural Steel - ASTM A500B

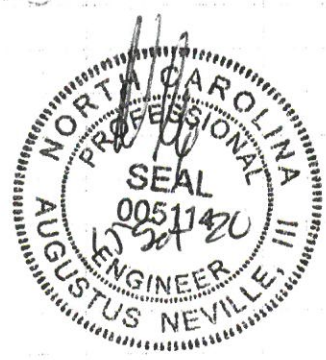

ORCHARD CREST ISLAND DIMENSIONS

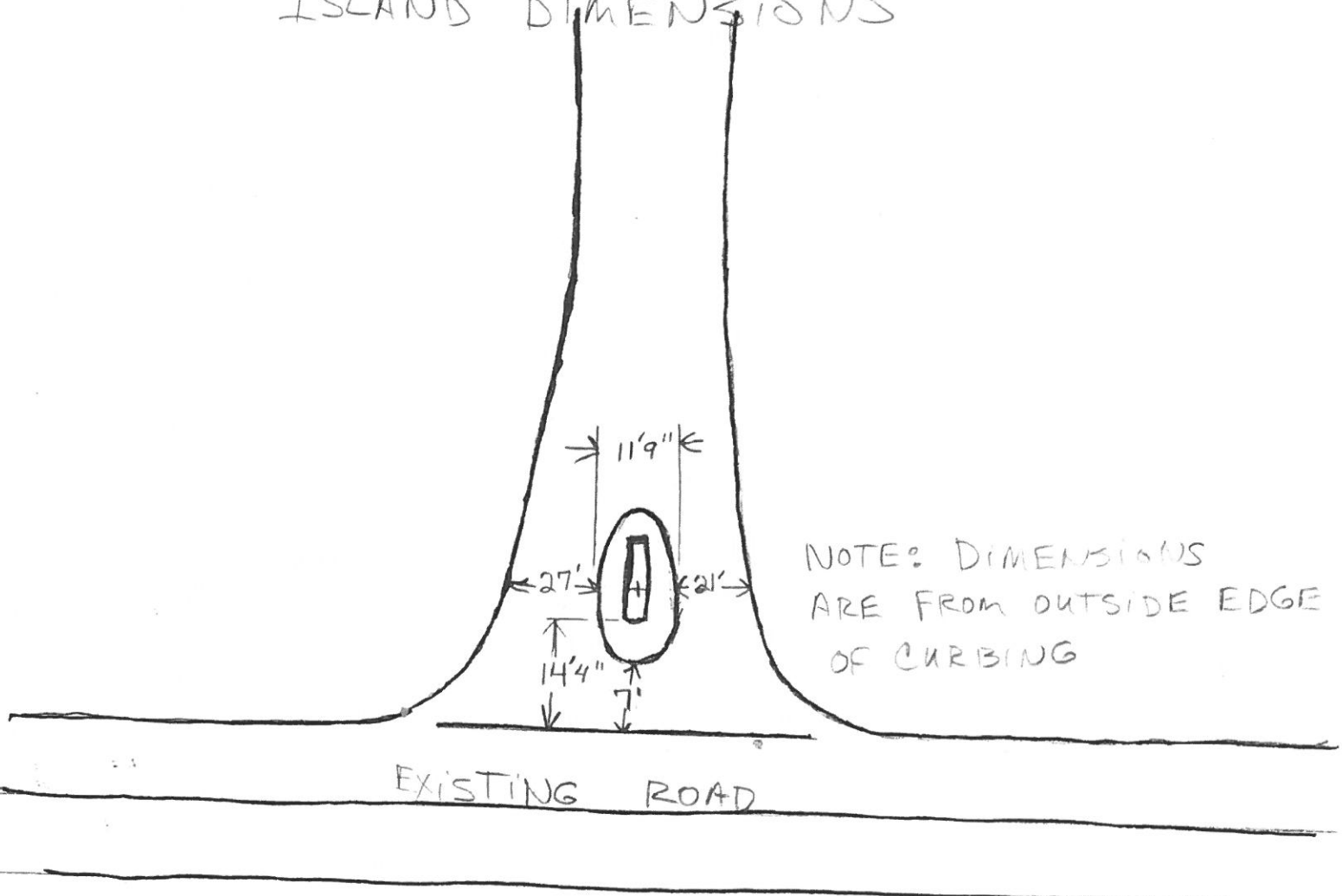

NOTE: DIMENSIONS
ARE FROM OUTSIDE EDGE
OF CURBING