



Initial Application Date: 5-10-19

Application # 516N1905-0001
DRB # _____ CU # _____

COMMERCIAL

COUNTY OF HARNETT LAND USE APPLICATION

Central Permitting (Physical) 108 E. Front Street, Lillington, NC 27546 (Mailing) PO Box 65 Lillington NC 27546 Phone: (910) 893-7525 opt # 2 Fax: (910) 893-2793 www.harnett.org/permits

LANDOWNER: Elmwood Holdings llc Mailing Address: P. O. Box 87555

City: Fayetteville State: NC Zip: 28304 Contact # _____ Email: _____

APPLICANT*: Sign & Awning Systems, Inc. Mailing Address: 2785 US Hwy 301 N.

City: Dunn State: NC Zip: 28334 Contact # 910-892-5900 Email: rtaylor@signandawning.net

*Please fill out applicant information if different than landowner

CONTACT NAME APPLYING IN OFFICE: Rachel Taylor / Jason Honeycutt Phone # 910-892-5900

Address: 1546 NC 24-87 Cameron PIN: 9584-88-6096.000

Deed Book Page: 2927 / 0417

PROPOSED USE:

- Multi-Family Dwelling No. Units: _____ No. Bedrooms/Unit: _____
- Business Sq. Ft. Retail Space: _____ Type: _____ # Employees: _____ Hours of Operation: _____
- Daycare # Preschoolers: _____ # Afterschoolers: _____ # Employees: _____ Hours of Operation: _____
- Industry Sq. Ft: _____ Type: _____ # Employees: _____ Hours of Operation: _____
- Church Seating Capacity: _____ # Bathrooms: _____ Kitchen: _____

Accessory/Addition/Other (Size 18" x 162") Use: 20 sq ft wall sign - 87 VAPE & TOBACCO

Water Supply: County Existing Well New Well (# of dwellings using well _____) *Must have operable water before final
(Need to Complete New Well Application at the same time as New Tank)

Sewage Supply: New Septic Tank Expansion Relocation Existing Septic Tank County Sewer
(Complete Environmental Health Checklist on other side of application if Septic)

Comments:

If permits are granted I agree to conform to all ordinances and laws of the State of North Carolina regulating such work and the specifications of plans submitted. I hereby state that foregoing statements are accurate and correct to the best of my knowledge. Permit subject to revocation if false information is provided.

Rachel Taylor for SA
Signature of Owner or Owner's Agent

5/3/19
Date

This application expires 6 months from the initial date if permits have not been issued

RECORDED DEED (OR OFFER TO PURCHASE) AND PLAT ARE REQUIRED WHEN APPLYING FOR LAND USE APPLICATION

It is the owner/applicants responsibility to provide the county with any applicable information about the subject property, including but not limited to: boundary information, house location, underground or overhead easements, etc. The county or its employees are not responsible for any incorrect or missing information that is contained within these applications.

This application expires 6 months from the initial date if permits have not been issued

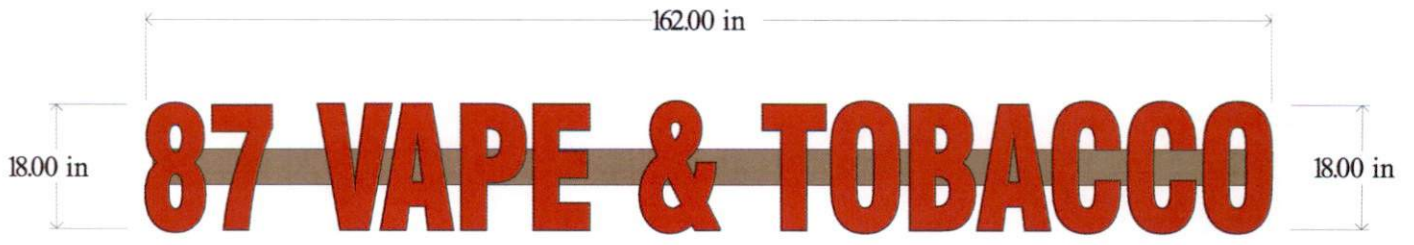

87 VAPE & TOBACCO
18" Channel Letters
SIGN & AWNING SYSTEMS, INC.
2785 US Hwy 301 N. Dunn NC 28334
PH 910.892.5900 FX 910.892.2140

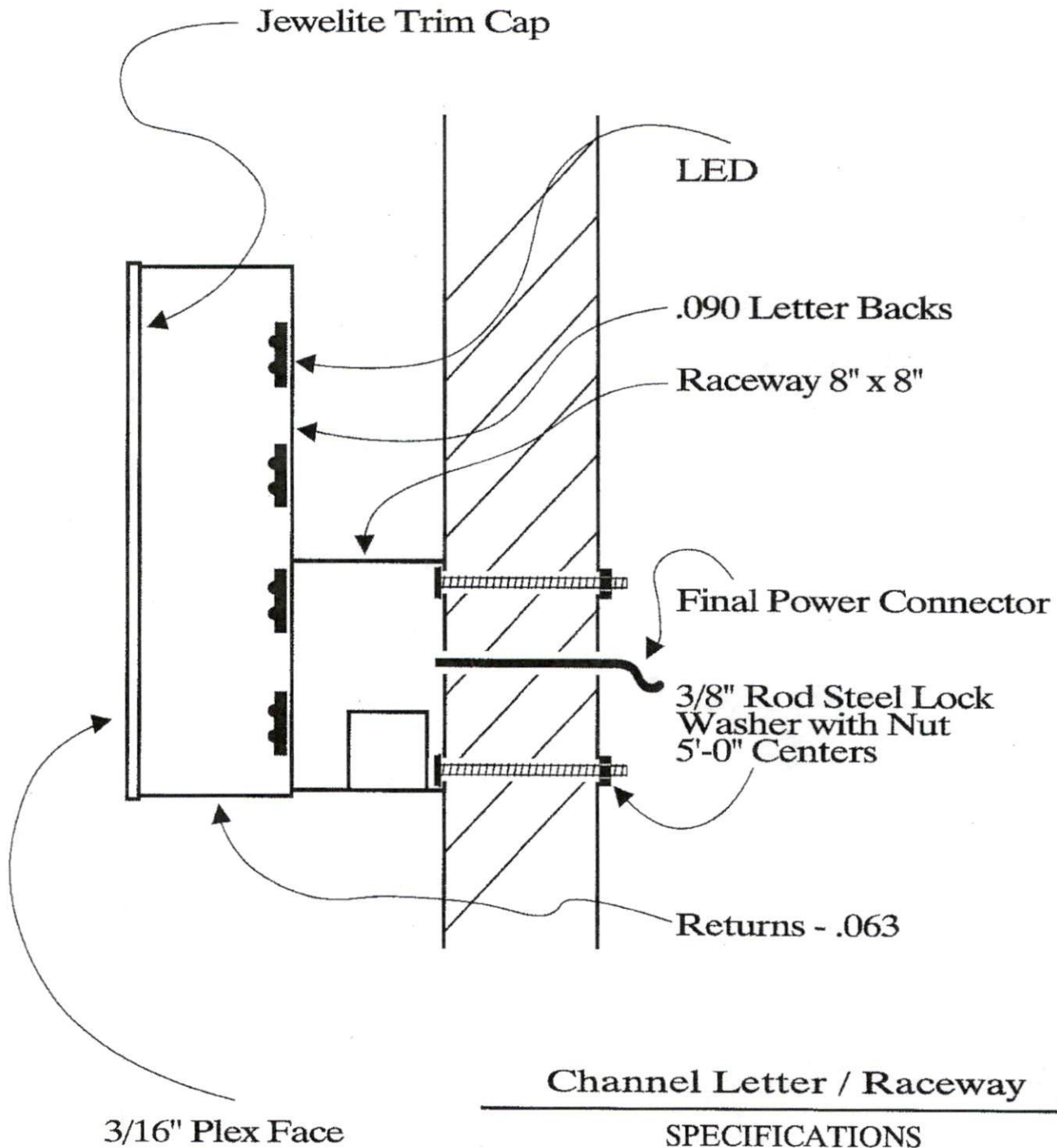

Letters, returns & cabinets manufactured to requirements and standards of the UNDERWRITERS LABORATORIES, INC.

SIGN & AWNING SYSTEMS, INC.

2785 US Hwy 301 N - Dunn NC 28334
 PH 910.892.5900 FX 910.892.2140