

**CONSTRUCTION AUTHORIZATION FOR G.S. 130A-335(a2)**

County: Harnett Pre-Construction Conference Required: Yes  No

PIN/Lot Identifier: 0519-69-7411.000

Issued To: LGI Homes NC LLC

Property Location: 85 Camp Rock Road, Lillington, NC

AOWE/PE Plans/Evaluations Provided: Yes  No  If yes, name and license number of AOWE/PE: Scott Mitchell - PE 27458

Facility Type: Single-Family Dwelling Unit

Number of bedrooms: 4 Number of Occupants: 8 or less Other: \_\_\_\_\_

New  Expansion  Repair  System Relocation  Change of Use

Basement?  Yes  No Basement Fixtures?  Yes  No

Crawl Space?  Yes  No Slab Foundation?  Yes  No

Type of Wastewater System\* IIB (Initial) IIB (Repair)

\*Please include system classification for proposed wastewater system types in accordance with Rule .1301 Table XXXII

Design Daily Flow: 480 GPD Wastewater Strength:  Domestic  High Strength  Industrial Process WW

Session Law 2014-120 Section 53, Engineering Design Utilizing Low-flow Fixtures and Low-flow Technologies?  Yes  No  
(if yes, please provide engineering documentation)

Effluent Standard:  DSE  HSE  NSF/ANSI 40  TS-I  TS-II  RCW

Type of Water Supply:  Private well  Public well  Shared well  Municipal Supply  Spring  Other: \_\_\_\_\_

**Installation Requirements/Conditions**

Septic Tank Size: 1,000 gallons Total Trench/Bed Length: 400 feet Trench/Bed Spacing: 9 feet on center

Trench/Bed Width: 36 inches LTAR: 0.30 gpd/ft<sup>2</sup> Usable Depth to LC (Initial)\*: 36"+ \*Limiting condition

Soil Cover: 12 inches Slope Corrected Maximum Trench/Bed Depth\*: 24 inches \* Measured on the downhill side of the trench

Pump Tank Size (if applicable): N/A gallons Requires more than 1 pump?  Yes  No

Pump Requirements: \_\_\_\_\_ ft. TDH vs. \_\_\_\_\_ GPM Grease Trap Size (if applicable): N/A gallons

Distribution Method:  Serial  D-Box or Parallel  Pressure Manifold(s)  LPP  Other: \_\_\_\_\_

Artificial Drainage Required: Yes  No  If yes, please specify details: \_\_\_\_\_

**Legal Agreements** (If the answer is "Yes" to any type of legal agreements, please attach a copy of the agreement.)

Multi-party Agreement Required [.0204(g)]:  Yes  No Declaration of Restrictive Covenants:  Yes  No

Easement, Right-of-Way, or Encroachment Agreement Required [.0301(b)]:  Yes  No

Management Entity Required:  Yes  No Minimum O&M Requirements: \_\_\_\_\_

Permit conditions:

Trench walls shall be raked when any Group III or Group IV soils are present.

Photo documentation of trench sidewall raking is required, where Group III or Group IV soils are present.

All lot corners and boundaries shall be clearly marked by a licensed surveyor prior to system installation.

Septic system installation not allowed when soil moisture conditions are near saturation within initial or repair drainfield areas.

No garbage disposals / insinkerators allowed in the house. County shall provide system O&M guidance materials to Owner.

The requirements of 15A NCAC 18E are incorporated by reference into this permit and shall be met. Systems shall be installed in accordance with the attached site sketch. *This Construction Authorization is subject to revocation if the site plan, plat, or the intended use changes.* The Construction Authorization shall not be affected by a change in ownership of the site. This Construction Authorization is subject to compliance with the provisions of 15A NCAC 18E, or 15A NCAC 18A .1900, as applicable, and to the conditions of this permit.

AOWE/PE Print Name: B. Scott Mitchell

AOWE/PE Signature: \_\_\_\_\_ Date: February 14, 2025

This AOWE/PE submittal is pursuant to and meets the requirements of G.S. 130A-335(a2) and (a5).

*\*See attached site sketch\**



### ***This Section for Local Health Department Use Only***

Initial submittal received: \_\_\_\_\_ by \_\_\_\_\_  
Date Initials

G.S. 130A-335(a5) states the following:

*When an applicant for a Construction Authorization, or an Improvement Permit and Construction Authorization together, submits a Construction Authorization, or an Improvement Permit and Construction Authorization application together, the permit fee charged by the local health department, the common form developed by the Department, and any necessary signed and sealed plans or evaluations conducted by a person licensed pursuant to Chapter 89C of the General Statutes as a licensed engineer or a person certified pursuant to Article 5 of Chapter 90A of the General Statutes as an Authorized On-Site Wastewater Evaluator, the local health department shall, within five business days of receiving the application, conduct a completeness review of the submittal. A determination of completeness means that the Construction Authorization or Improvement Permit and Construction Authorization includes all of the required components. If the local health department determines that the Construction Authorization or Improvement Permit and Construction Authorization is incomplete, the local health department shall notify the applicant of the components needed to complete the Construction Authorization or Improvement Permit and Construction Authorization. The applicant may submit additional information to the local health department to cure the deficiencies in the Construction Authorization or Improvement Permit and Construction Authorization. The local health department shall make a final determination as to whether the Construction Authorization or Improvement Permit and Construction Authorization is complete within five business days after the local health department receives the additional information from the applicant. If the local health department fails to act within any period set out in this subsection, the applicant may treat the failure to act as a determination of completeness. The applicant may apply for the building permit for the project upon the decision of completeness of the Construction Authorization or Improvement Permit and Construction Authorization by the local health department or if the local health department fails to act within five business days. The Authorized On-Site Wastewater Evaluator or licensed engineer submitting the evaluation pursuant to this subsection may request that the local health department revoke or suspend the Construction Authorization or Improvement Permit and Construction Authorization for cause. Upon written request of the Authorized On-Site Wastewater Evaluator or licensed engineer, the local health department shall suspend or revoke the Construction Authorization or Improvement Permit and Construction Authorization pursuant to G.S. 130A-23. The Department shall develop a common form for use as the Construction Authorization.*

The review for completeness of this Construction Authorization was conducted in accordance with G.S. 130A-335(a5). This

Construction Authorization is determined to be:

Incomplete (If box is checked, information in this section is required.)

The following items are missing: \_\_\_\_\_  
\_\_\_\_\_

Copies of this were sent to the AOWE/PE and the Applicant on \_\_\_\_\_  
Date

State Authorized Agent: \_\_\_\_\_ Date: \_\_\_\_\_

Complete

State Authorized Agent: \_\_\_\_\_ Date of Issuance: \_\_\_\_\_

**This Construction Authorization is issued pursuant to G.S. 130A-335(a2) and (a5) using the signed and sealed plans or evaluations attached here. This Construction Authorization is subject to revocation if the site plan, plat, or the intended use changes. The Construction Authorization shall not be affected by a change in ownership of the site. This Construction Authorization is subject to compliance with the provisions of the Laws and Rules for Sewage Treatment and Disposal and to the conditions of this permit.**

**The Department, the Department's authorized agents, and the local health departments shall be discharged and released from any liabilities, duties, and responsibilities imposed by statute or in common law from any claim arising out of or attributed to plans, evaluations, preconstruction conference findings, submittals, or actions from a person licensed pursuant to Chapter 89C of the General Statutes as a licensed engineer or a person certified pursuant to Article 5 of Chapter 90A of the General Statutes as an Authorized On-Site Wastewater Evaluator in GS 130A-335(a2), (a5), and (a7). The Department, the Department's authorized agents, and the local health departments shall be responsible and bear liability for their actions and evaluations and other obligations under State law or rule, including the issuance of the operations permit pursuant to GS 130A-337.**

**Construction Authorization Expiration Date:** \_\_\_\_\_

**\*See attached site sketch\***

## Re-submittal of Construction Authorization

LHD USE ONLY: This CA resubmittal received: \_\_\_\_\_ by \_\_\_\_\_  
*Date* *Initials*

The following items are being resubmitted pursuant to G.S. 130A-335(a5) for issuance of the Construction Authorization:

---



---



---



---

I, \_\_\_\_\_ hereby attest that the information required to be included with this re-submittal  
*Authorized Onsite Wastewater Evaluator (Print Name)*  
 is accurate and complete to the best of my knowledge and that the proposed Construction Authorization meets all applicable federal, State, and local laws, regulations, rules, and ordinances.

\_\_\_\_\_  
*Signature of Authorized On-Site Wastewater Evaluator* *Date*

***The section below is for Local Health Department use after submittal of items noted as missing above.***

### LHD Follow-up Completeness Review of Construction Authorization

The review for completeness of this Construction Authorization re-submittal was conducted in accordance with G.S. 130A-335(a5). This Construction Authorization is determined to be:

Incomplete (If box is checked, information in this section is required.)

The following items are missing:

---



---

Copies of this were sent to the AOWE/PE and the Applicant on \_\_\_\_\_  
*Date*

State Authorized Agent: \_\_\_\_\_ Date: \_\_\_\_\_

Complete

State Authorized Agent: \_\_\_\_\_ Date: \_\_\_\_\_

**ADDENDUM TO G.S. 130A-335(a2) SUBMITTAL**

County: \_\_\_\_\_

PIN/Lot Identifier: \_\_\_\_\_

Issued To: \_\_\_\_\_

**Additional Improvement Permit Conditions:**

---

---

---

---

---

---

---

---

---

---

---

---

---

---

---

---

---

---

---

---

---

---

---

**Additional Construction Authorization Conditions:**

---

---

---

---

---

---

---

---

---

---

---

---

---

---

---

---

---

---

---

---

---

---

---

# Mitchell Environmental, P.A.

I hereby authorize representatives of Mitchell Environmental, P.A., to provide subsurface wastewater evaluations and septic system designs on my behalf, for the issuance of an IP and CA, for the property identified below.

For Improvement Permit (IP) issuance:

"The LSS/LG evaluation(s) attached to this application is to be used to issue an Improvement Permit in accordance with G.S. 130A-335(a2) and (a3)."

For Construction Authorization (CA) issuance:

"The plans or evaluations attached to this application are to be used to issue a Construction Authorization in accordance with G.S. 130A-335(a2), (a5), and (a6)."

The LSS evaluation attached to this application was used to produce and design a subsurface wastewater septic system for permitting to obtain an IP and CA in accordance with G.S. 130A-335(a2), (a3), (a5), and (a6).

Subject Property (Address, PIN, etc.): 41/63/85/92/70 Camp Rock Rd.  
46 Camp Rock Rd. Lillington NC 27546

Property Owner Name (Print): LGI Homes

Owner Representative (Print): Keith Sears

Owner Representative (Sign): 

Date: 2/10/25

1501 Lakestone Village Lane, Suite 205  
Fuquay-Varina, North Carolina 27526  
919-669-0329



CERTIFICATE OF LIABILITY INSURANCE

DATE (MM/DD/YYYY) 1/16/2025

THIS CERTIFICATE IS ISSUED AS A MATTER OF INFORMATION ONLY AND CONFERS NO RIGHTS UPON THE CERTIFICATE HOLDER. THIS CERTIFICATE DOES NOT AFFIRMATIVELY OR NEGATIVELY AMEND, EXTEND OR ALTER THE COVERAGE AFFORDED BY THE POLICIES BELOW. THIS CERTIFICATE OF INSURANCE DOES NOT CONSTITUTE A CONTRACT BETWEEN THE ISSUING INSURER(S), AUTHORIZED REPRESENTATIVE OR PRODUCER, AND THE CERTIFICATE HOLDER.

IMPORTANT: If the certificate holder is an ADDITIONAL INSURED, the policy(ies) must have ADDITIONAL INSURED provisions or be endorsed. If SUBROGATION IS WAIVED, subject to the terms and conditions of the policy, certain policies may require an endorsement. A statement on this certificate does not confer rights to the certificate holder in lieu of such endorsement(s).

Table with PRODUCER (Alera Group) and INSURED (Mitchell Environmental PA) information, and CONTACT details for Select Business Unit (Westchester Surplus Lines and Sirius America Insurance Company).

COVERAGES

CERTIFICATE NUMBER:

REVISION NUMBER:

THIS IS TO CERTIFY THAT THE POLICIES OF INSURANCE LISTED BELOW HAVE BEEN ISSUED TO THE INSURED NAMED ABOVE FOR THE POLICY PERIOD INDICATED. NOTWITHSTANDING ANY REQUIREMENT, TERM OR CONDITION OF ANY CONTRACT OR OTHER DOCUMENT WITH RESPECT TO WHICH THIS CERTIFICATE MAY BE ISSUED OR MAY PERTAIN, THE INSURANCE AFFORDED BY THE POLICIES DESCRIBED HEREIN IS SUBJECT TO ALL THE TERMS, EXCLUSIONS AND CONDITIONS OF SUCH POLICIES. LIMITS SHOWN MAY HAVE BEEN REDUCED BY PAID CLAIMS.

Main coverage table with columns for INSR LTR, TYPE OF INSURANCE, POLICY NUMBER, POLICY EFF, POLICY EXP, and LIMITS. Includes Commercial General Liability, Automobile Liability, Umbrella Liability, and Workers Compensation.

DESCRIPTION OF OPERATIONS / LOCATIONS / VEHICLES (ACORD 101, Additional Remarks Schedule, may be attached if more space is required) Operations of the Named Insured covered by the above referenced policies.

CERTIFICATE HOLDER

CANCELLATION

Table for Certificate Holder (LGI Homes - NC, LLC) and Cancellation details (Authorized Representative: Erin Marty).

**Mitchell Environmental, P.A.**

**SEPTIC SYSTEM DESIGN**

for

**BOONE TRAIL VILLAGE SUBDIVISION- LOT 49**

Lillington, Harnett County, North Carolina

**Submitted to:**

Harnett County Health Department  
307 Cornelius Harnett Blvd.  
Lillington, NC 27546

**Prepared for:**

LGI Homes  
5511 Capital Center Drive  
Suite 560  
Raleigh, North Carolina 27612

**Prepared by:**

Scott Mitchell, PE, LSS  
Adam Aycok, EI

**DATE: February 4, 2025**  
**PROJECT NO.: 1624**

2-4-2025





# Harnett County GIS

**PID:** 130519 0103 54  
**PIN:** 0519-69-7411.000  
**Account Number:** 1500028388  
**Owner:** LGI HOMES NC LLC  
**Mailing Address:** 1450 LAKE ROBBINS DR STE 430 THE WOODLANDS, TX 77380-3294  
**Physical Address:** 85 CAMP ROCK RD LILLINGTON, NC 27546 ac  
**Description:** LOT#49 BOONE TRAIL VILLAGE PH1 MAP#2024-600  
**Surveyed/Deeded Acreage:** 0.59  
**Calculated Acreage:** 0.59  
**Deed Date:**  
**Deed Book/Page:** 4144 - 0878  
**Plat(Survey) Book/Page:** 2024 - 600  
**Last Sale:** 2022 - 4  
**Sale Price:** \$2220000  
**Qualified Code:** A  
**Vacant or Improved:** V  
**Transfer of Split:** T  
**Actual Year Built:**  
**Heated Area :** SqFt  
**Building Count :** 0

**Building Value:** \$0  
**Parcel Outbuilding Value:** \$0  
**Parcel Land Value:** 26020  
**Market Value:** \$26020  
**Deferred Value:** \$0  
**Total Assessed Value:** \$26020  
**Zoning:** RA-30 - 0.59 acres (100.0%)  
**Zoning Jurisdiction:** Harnett County  
**Wetlands:** No  
**FEMA Flood:** Minimal Flood Risk  
**Within 1mi of Agriculture District:** Yes  
**Elementary School:** Boone Trail Elementary  
**Middle School:** Western Harnett Middle  
**High School:** Western Harnett High  
**Fire Department:** Boone Trail  
**EMS Department:** Medic 12, D12 EMS  
**Law Enforcement:** Harnett County Sheriff  
**Voter Precinct:** Boone Trail  
**County Commissioner :** Duncan Edward Jagers  
**School Board Member:** John Hair

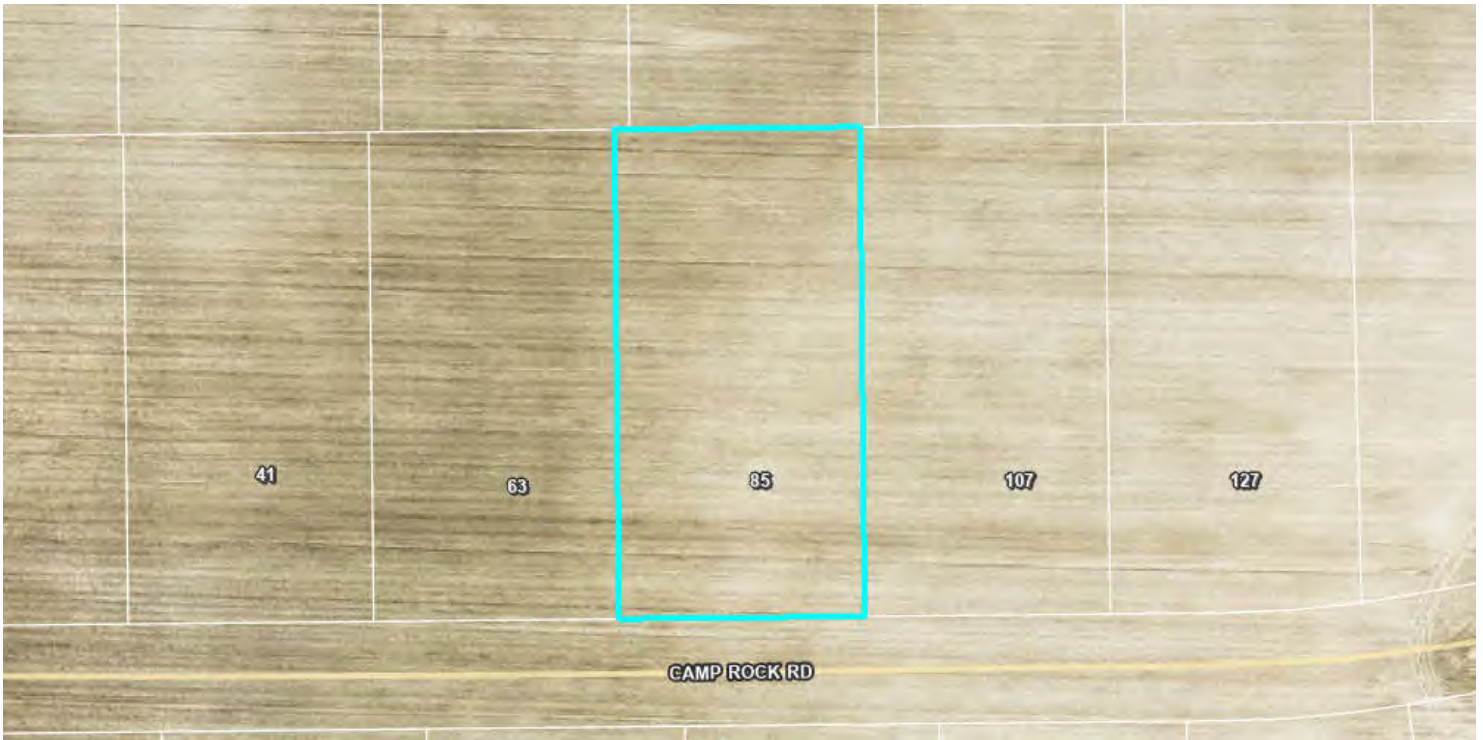



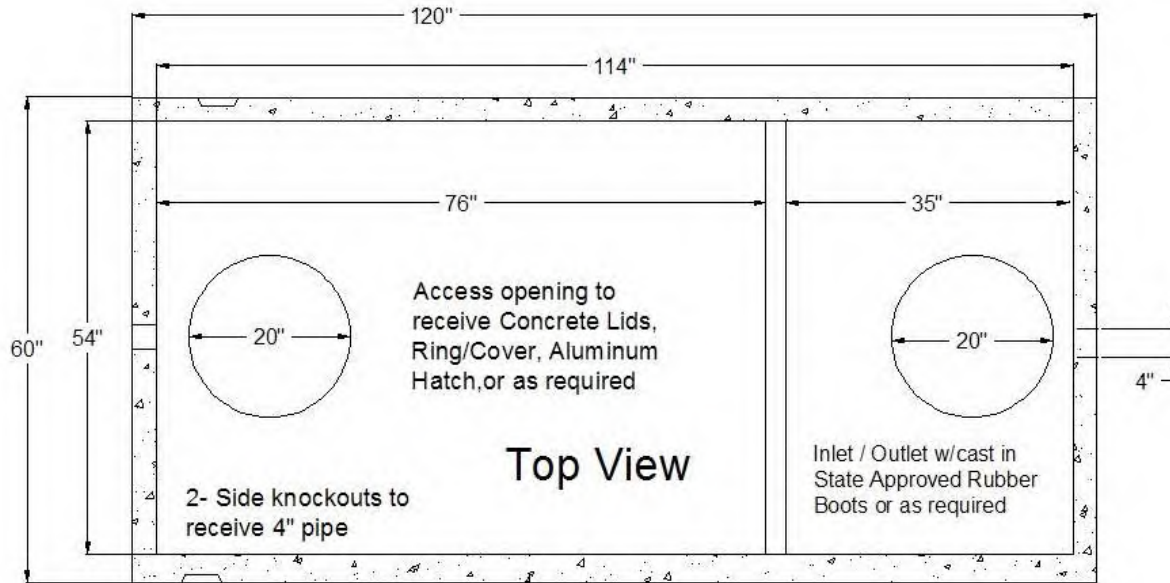

## STB - 345 - Top Seam

Approval Date: 12 - 09 - 99

Liquid Capacity 1007 Gallons

Non Traffic Rated

Reinforcing Schedule: # 3 Grade 60 Rebar

4500 PSI Concrete w/ State Approved Structural Fiber

Est. Weight: 8,200 lbs.

Manufactured By:

# GARNERS

**Septic Tanks, Inc.**

Eddie Garner, President

919-718-5181

121 Stanton Hill Road

Carthage, NC 28327

Fax 919-775-2229

Eddie@garnersseptic tanks.com

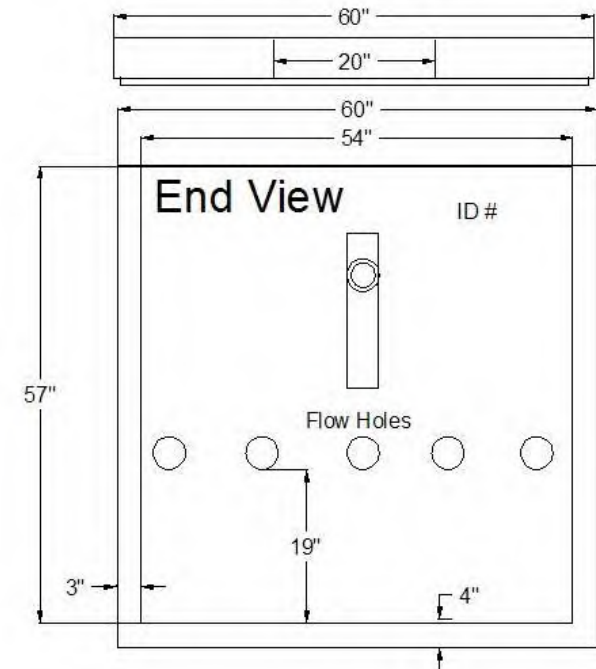
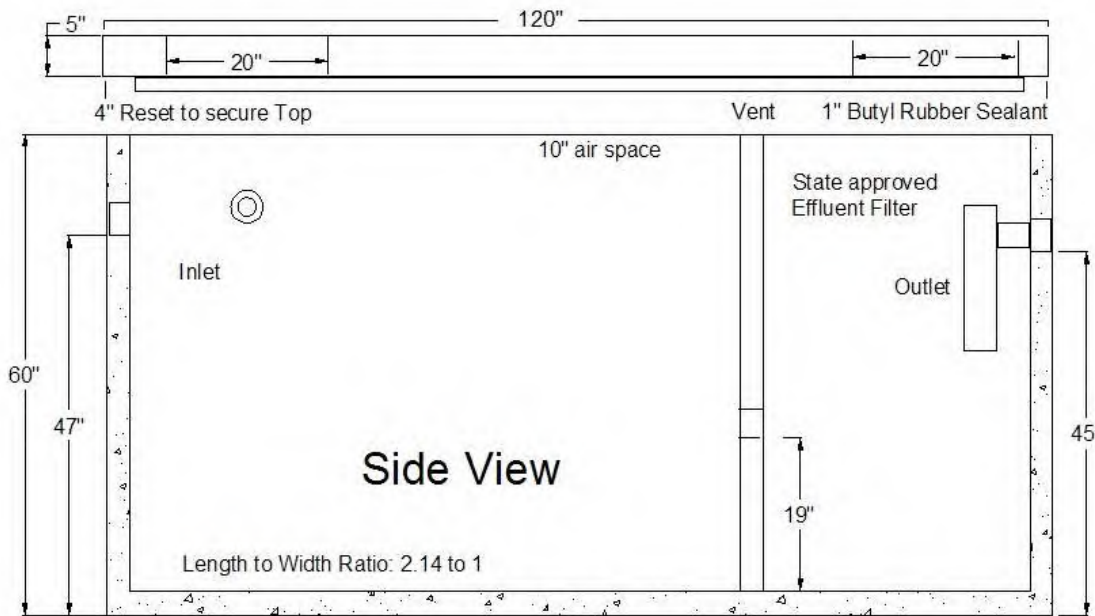

**PL-68 Filter and Tee**

PL-68 is much more than just an effluent filter. The housing can also be used as an inlet baffle (tee) or an outlet baffle. The housing is designed to accept Polylok’s snap in gas deflector to deflect gas bubbles away from the tee and to keep the solids in the tank.

**Features:**

- Offers 68 linear feet of 1/16” filter slots, which significantly extends time between cleaning.
- Accepts 3/4” PVC handle.
- Locks in any 360° position when used with PL-68 Tee.
- PL-68 Housing can be used as an inlet or outlet tee.
- Gasket prevents bypass.

**PL-68 Installation:**

Ideal for residential waste flows up to 800 gallons per day (GPD). Easily installs in any new or existing 4" outlet tee.

1. Locate the outlet of the septic tank.
2. Remove the tank cover and pump tank if necessary.
3. Glue the filter housing to the outlet pipe, or use a Polylok Extend & Lok if not enough pipe exists.
4. Insert the PL-68 filter into tee.
5. Replace and secure the septic tank cover.

**PL-68 Maintenance:**

The PL-68 Effluent Filter will operate efficiently for several years under normal conditions before requiring cleaning. It is recommended that the filter be cleaned every time the tank is pumped, or at least every three years.

1. Do not use plumbing when filter is removed.
2. Pull PL-68 out of the tee.
3. Hose off filter over the septic tank. Make sure all solids fall back into septic tank.
4. Insert filter back into tee/housing.

**Related Products:**

PL-68 Filter Concrete Baffle  
 Extend & Lok™

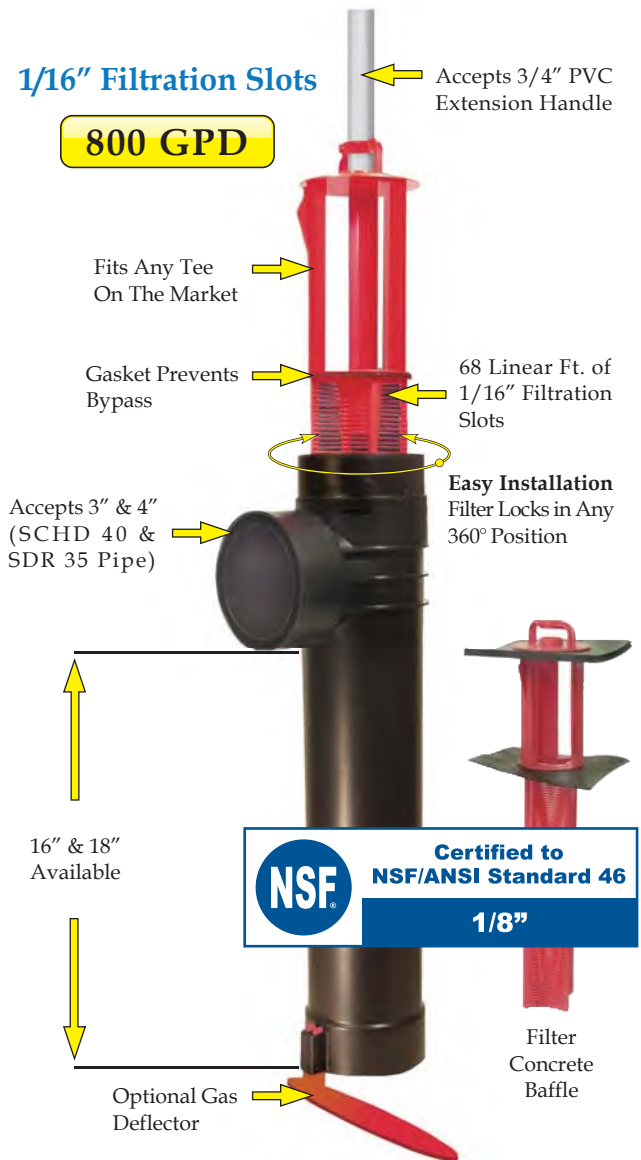

**Extend & Lok™**  
 Easily installs into existing tanks.



Spacer Bushing  
 4" SCHD 40 to SDR 35



Spacer Bushing  
 4" SCHD 40 to 110mm Pipe



2" Extender



EZflow by Infiltrator is an environmentally friendly replacement to traditional stone and pipe drainfields using an engineered geosynthetic aggregate modular design. The EZflow system is designed to improve infiltration performance by eliminating the fines associated with crushed stone, and reducing compaction and embedment associated with stone. Preassembled units include a 3" or 4" perforated pipe surrounded by aggregate and held in place with a durable high-strength netting. This product comes in easy-to-contour 5' and 10' lengths and in diameters of 7, 8, 9, 10, 12, 13, or 14 inches.

**Lightweight expanded polystyrene** construction offers structural integrity and resists compaction. Engineered flow-channels increase void space creating improved water flow and greater storage.



## Compared with stone and pipe, benefits include:

- Always clean and free of fines
- Bundles are quick to install, saving costs on heavy machinery and labor
- Modular construction allows configurations to match trench dimensions for most system shapes and sizes
- Engineered for optimal storage and absorption efficiencies
- Ability to contour along sloped sites and around trees or landscaping
- Lightweight system is perfect for repairs and tight job sites
- Easily hand-carried into position reducing time and labor
- 5' or 10' lengths with simple snap, internal couplers
- Easier cleanup at the job site with the elimination of stone
- Manufactured from recycled materials rather than a mined natural resource
- A wide variety of diameters and configurations to meet any installation professional's needs
- Approved in many jurisdictions with an increased efficiency rating, reducing drainfield size
- Backed by the leader in the onsite wastewater industry

**Bundle System Configurations:** Available in 7", 8", 9", 10", 12", 13" and 14" diameter bundles.

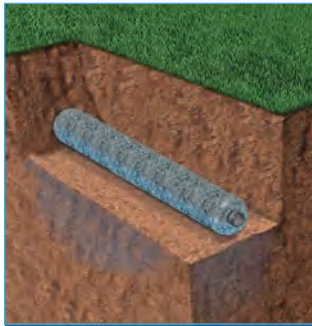

**Single Bundle**

0701P-GEO 1201P-GEO  
0801P-GEO 1401P-GEO  
1201P-GEO 1801P-GEO  
1001P-GEO

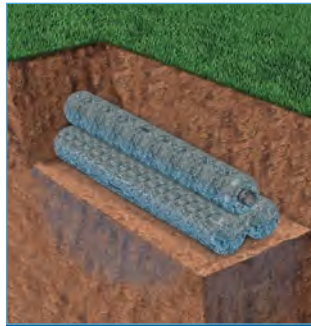

**Triangular Bundle**

1003T-GEO 1303T-GEO  
1203T-GEO 1403T-GEO



**Horizontal Bundles**

0705H-GEO 1303H-GEO  
0904H-GEO 1202H-GEO  
1002H-GEO 1203H-GEO



1206H-GEO 1402H-GEO  
1303H-GEO 1802H-GEO



**Vertical Bundles**

1002V-GEO 1006V-GEO 1203V-GEO 1206V-GEO  
1003V-GEO 1202V-GEO 1204V-GEO 1402V-GEO  
1004V-GEO



**Notes:**

1. Other systems include 10" and 12" bed systems. Bed size will dictate the number of bundles.
2. System dimensions are dependent upon bundle diameter and configuration.
3. LLP is for "Low Pressure Pipe" in which a pressurized distribution pipe is field installed within the corrugated pipe.
4. Internal pipe and couplings meet the requirements of ASTM F405.
5. Bundles are also available without geotextile between the netting and synthetic aggregate.

**INFILTRATOR WATER TECHNOLOGIES STANDARD LIMITED WARRANTY**

(a) The structural integrity of each EZflow by Infiltrator expanded polystyrene drainfield system and other accessories manufactured by EZflow by Infiltrator ("Units"), when installed and operated in a leachfield of an onsite septic system in accordance with Infiltrator's instructions, is warranted to the original purchaser ("Holder") against defective materials and workmanship for one year from the date that the septic permit is issued for the septic system containing the Units; provided, however, that if a septic permit is not required by applicable law, the warranty period will begin upon the date that installation of the septic system commences. To exercise its warranty rights, Holder must notify Infiltrator in writing at its Corporate Headquarters in Old Saybrook, Connecticut within fifteen (15) days of the alleged defect. Infiltrator will supply replacement Units for Units determined by EZflow by Infiltrator to be covered by this Limited Warranty. EZflow by Infiltrator's liability specifically excludes the cost of removal and/or installation of the Units.

(b) THE LIMITED WARRANTY AND REMEDIES IN SUBPARAGRAPH (a) ARE EXCLUSIVE. THERE ARE NO OTHER WARRANTIES WITH RESPECT TO THE UNITS, INCLUDING NO IMPLIED WARRANTIES OF MERCHANTABILITY OR FITNESS FOR A PARTICULAR PURPOSE

(c) This Limited Warranty shall be void if any part of the EZflow system is manufactured by anyone other than EZflow by Infiltrator. The Limited Warranty does not extend to incidental, consequential, special or indirect damages. Infiltrator shall not be liable for penalties or liquidated damages, including loss of production and profits, labor and materials, overhead costs, or other losses or expenses incurred by the Holder or any third party. Specifically excluded from Limited Warranty coverage are damage to the Units due to ordinary wear and tear, alteration, accident, misuse, abuse or neglect of the Units; the Units being subjected to vehicle traffic or other conditions which are not permitted by the installation instructions; failure to maintain the minimum ground covers set forth in the installation instructions; the placement of improper materials into the system containing the Units; failure of the Units or the septic system due to improper siting or improper sizing, excessive water usage, improper grease disposal, or improper operation; or any other event not caused by Infiltrator. This Limited Warranty shall be void if the Holder fails to comply with all of the terms set forth in this Limited Warranty. Further, in no event shall Infiltrator be responsible for any loss or damage to the Holder, the Units, or any third party resulting from installation or shipment, or from any product liability claims of Holder or any third party. For this Limited Warranty to apply, the Units must be installed in accordance with all site conditions required by state and local codes; all other applicable laws; and Infiltrator's installation instructions.

(d) No representative of Infiltrator has the authority to change or extend this Limited Warranty. No warranty applies to any party other than the original Holder.

The above represents the Standard Limited Warranty offered by Infiltrator. A limited number of states and counties have different warranty requirements. Any purchaser of Units should contact Infiltrator's Corporate Headquarters in Old Saybrook, Connecticut, prior to such purchase, to obtain a copy of the applicable warranty, and should carefully read that warranty prior to the purchase of Units.



4 Business Park Road  
P.O. Box 768  
Old Saybrook, CT 06475  
860-577-7000 • Fax 860-577-7001  
**1-800-221-4436**  
[www.infiltratorwater.com](http://www.infiltratorwater.com)

U.S. Patents: 4,759,661; 5,017,041; 5,156,488; 5,336,017; 5,401,116; 5,401,459; 5,511,903; 5,716,163; 5,588,778; 5,839,844 Canadian Patents: 1,329,959; 2,004,564 Other patents pending. Infiltrator, Equalizer, Quick4, and SideWinder are registered trademarks of Infiltrator Water Technologies. Infiltrator is a registered trademark in France. Infiltrator Water Technologies is a registered trademark in Mexico. Contour, MicroLeaching, PolyTuff, ChamberSpacer, MultiPort, PosiLock, QuickCut, QuickPlay, SnapLock and StraightLock are trademarks of Infiltrator Water Technologies. PolyLok is a trademark of PolyLok, Inc. TUF-TITE is a registered trademark of TUF-TITE, INC. Ultra-Rib is a trademark of IPEX Inc.

© 2015 Infiltrator Water Technologies, LLC. All rights reserved. Printed in U.S.A.

EZ01 0315AG

**Contact Infiltrator Water Technologies' Technical Services Department for assistance at 1-800-221-4436**

4-Bedroom  
 LTAR: 0.3 gpd/ft<sup>2</sup>  
 Initial: Gravity-to-Innovative 25%  
 Reduction Status Product utilizing  
 lines 7-10 (400')  
 Repair: Gravity-to-Innovative 25%  
 Reduction Status Product utilizing  
 lines 3-6 (400')

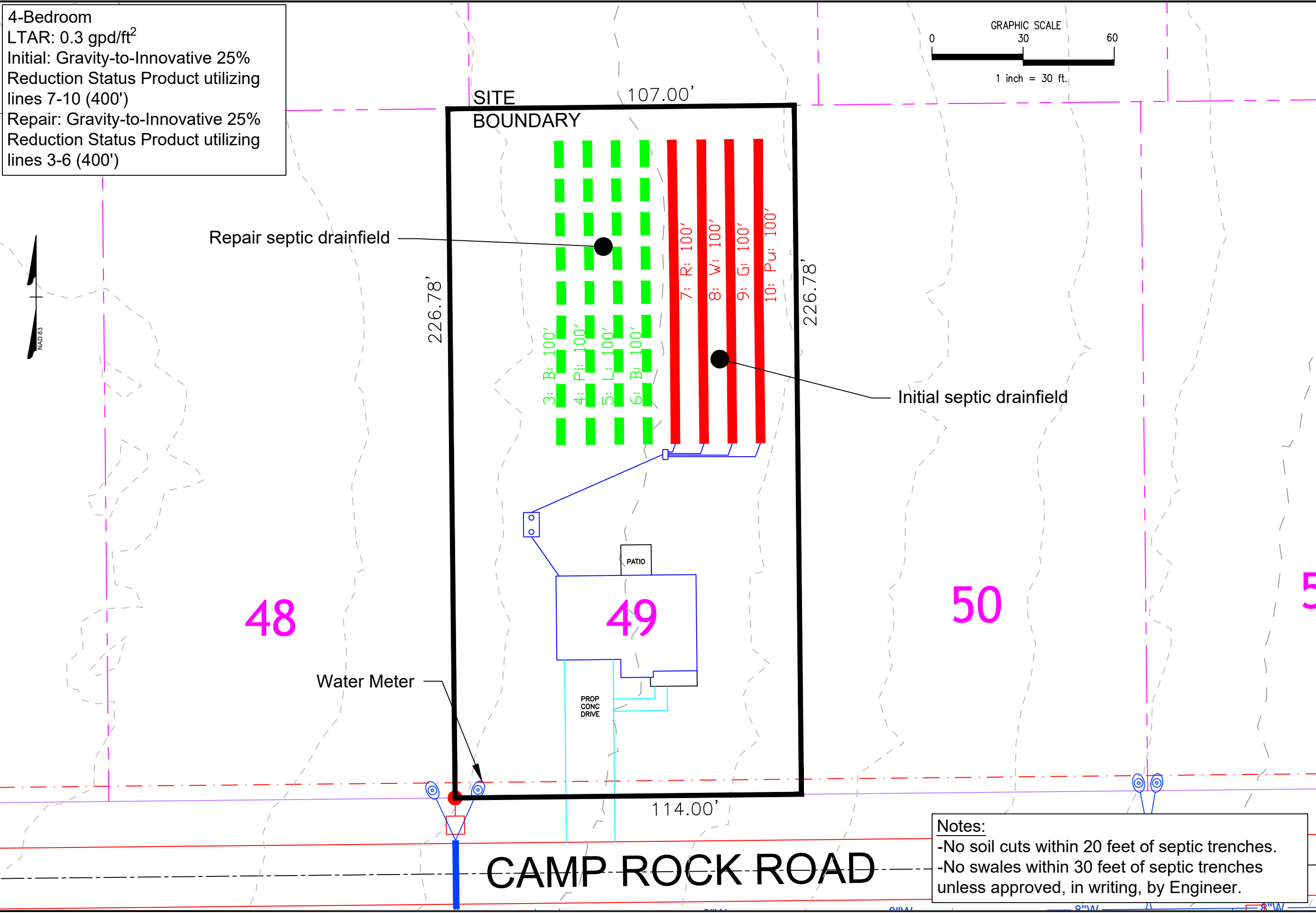
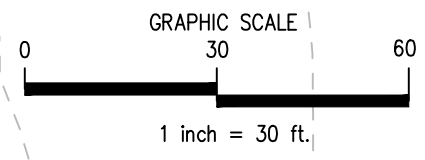

**Notes:**  
 -No soil cuts within 20 feet of septic trenches.  
 -No swales within 30 feet of septic trenches  
 unless approved, in writing, by Engineer.

<b>MITCHELL ENVIRONMENTAL, PA</b> C-2917		<b>SHEET NUMBER</b> 1 of 5	
1501 LAKESTONE VILLAGE LANE SUITE 205 FUQUAY VARINA, NC 27526		Boone Trail Village Lot 49 Overall Septic	
PREPARED FOR : LGI Homes 5511 Capital Center Drive Suite 560 Raleigh, NC 27612	DATE : February 4, 2025	REVISION NO. Original Submittal	DATE February 4, 2025
DESIGNER CONTACT: ADAM AYCOCK, EI	DRAWN BY: ADAM AYCOCK, EI	Revision 1	-----
		Revision 2	-----
		Revision 3	-----
		Master Set	-----

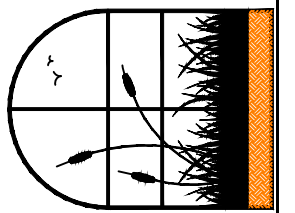

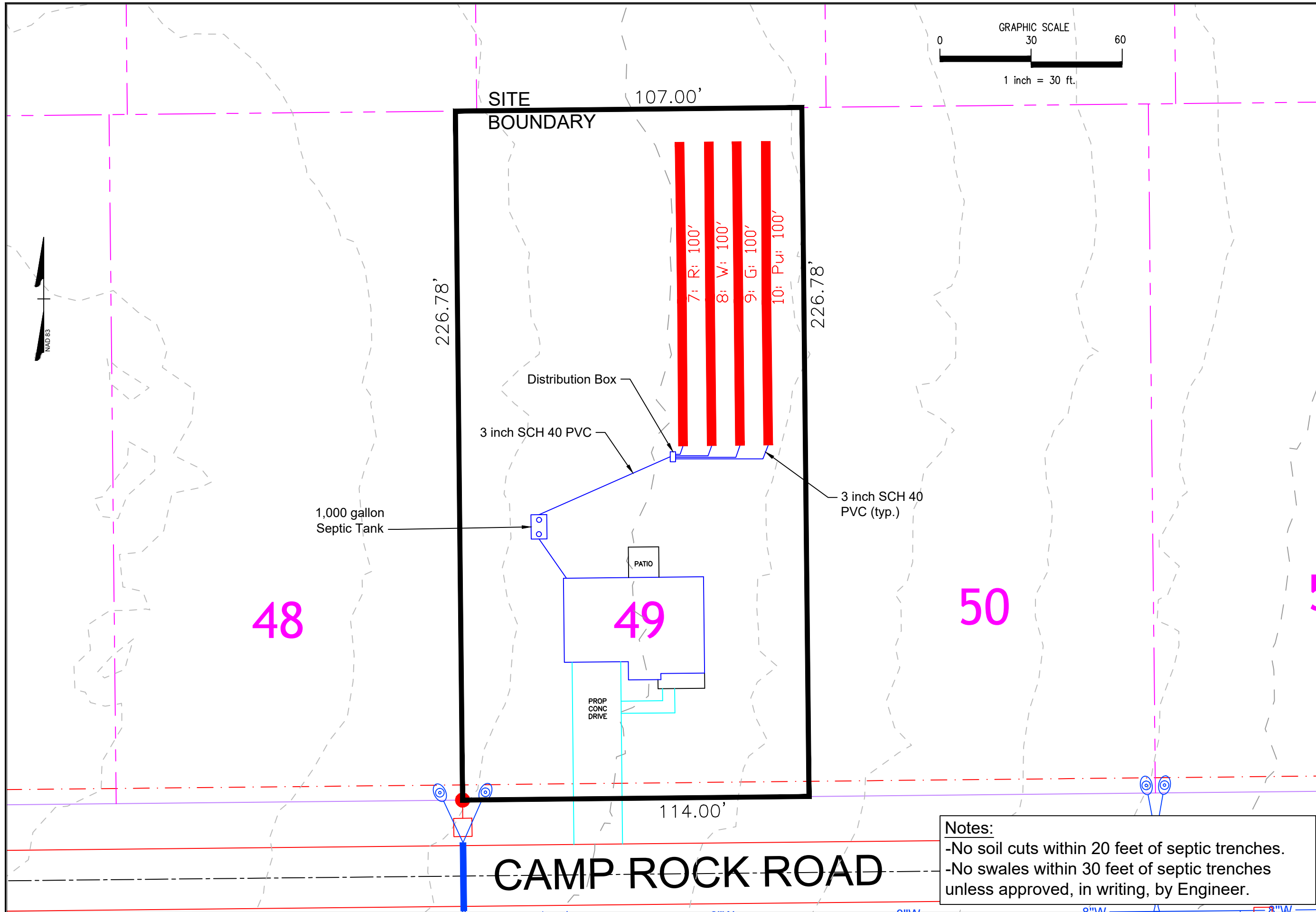

**Notes:**  
 -No soil cuts within 20 feet of septic trenches.  
 -No swales within 30 feet of septic trenches unless approved, in writing, by Engineer.

<b>MITCHELL ENVIRONMENTAL, PA</b> C-2917 1501 LAKESTONE VILLAGE LANE SUITE 205 FUQUAY VARINA, NC 27526		PREPARED FOR : LCI Homes 5511 Capital Center Drive Suite 560 Raleigh, NC 27612	REVISION NO. Original Submittal Revision 1 Revision 2 Revision 3 Master Set	DATE February 4, 2025 ----- ----- ----- -----	<b>SHEET NUMBER</b> 2 of 5 Boone Trail Village Lot 49 Initial Nitritification Field
DATE : February 4, 2025 DESIGNER CONTACT: ADAM AYCOCK, EI DRAWN BY: ADAM AYCOCK, EI					

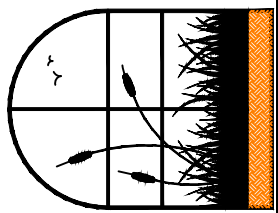

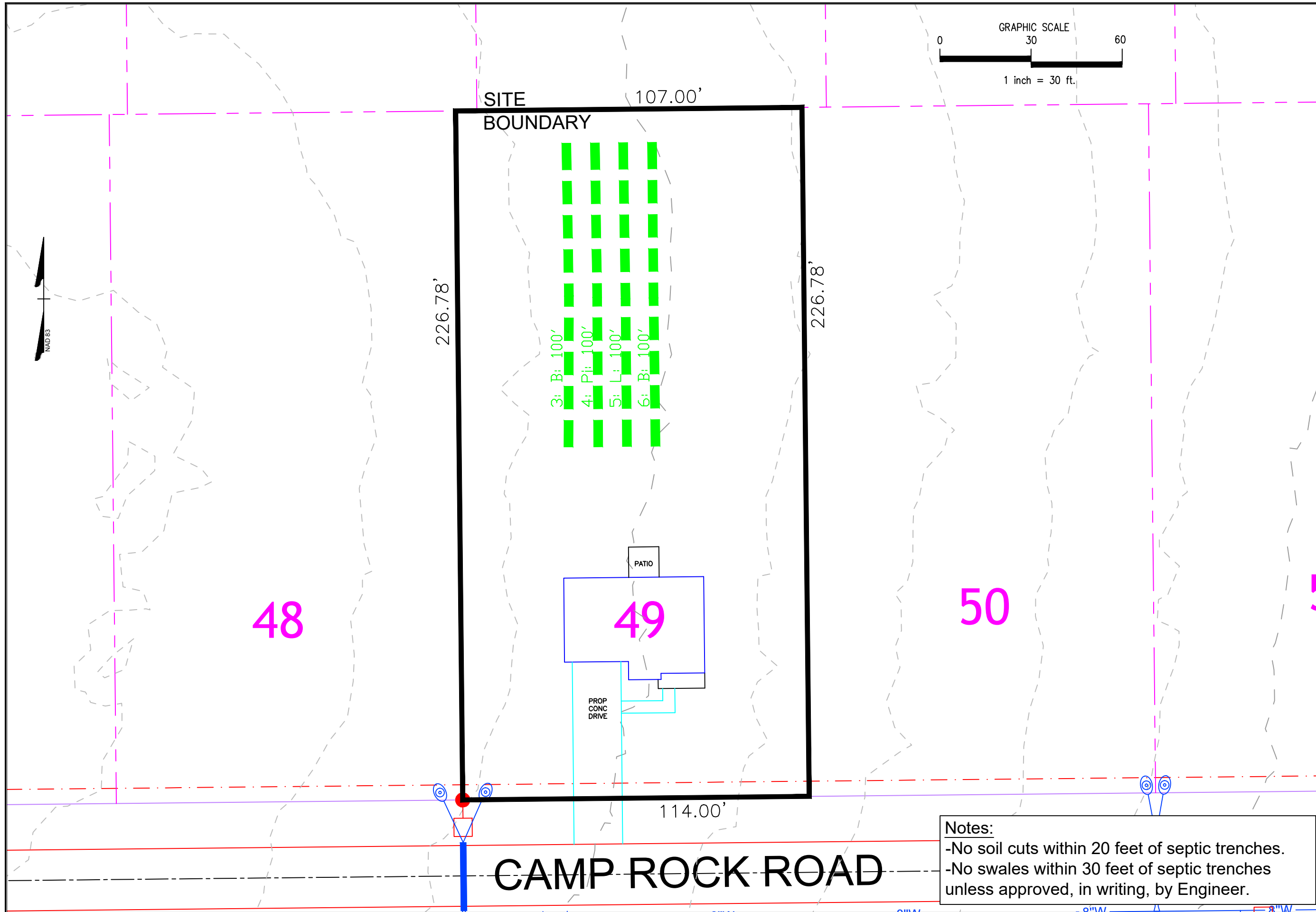

**Notes:**  
 -No soil cuts within 20 feet of septic trenches.  
 -No swales within 30 feet of septic trenches unless approved, in writing, by Engineer.

<b>MITCHELL ENVIRONMENTAL, PA</b> C-2917 1501 LAKESTONE VILLAGE LANE SUITE 205 FUQUAY VARINA, NC 27526		PREPARED FOR : LCI Homes 5511 Capital Center Drive Suite 560 Raleigh, NC 27612	REVISION NO. Original Submittal Revision 1 Revision 2 Revision 3 Master Set	DATE February 4, 2025 ----- ----- ----- -----	<b>SHEET NUMBER</b> 3 of 5 Boone Trail Village Lot 49 Repair Nitrification Field
--	--	--	--	--	--

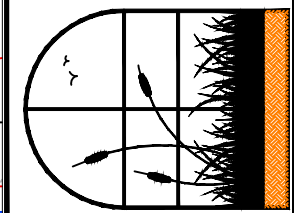

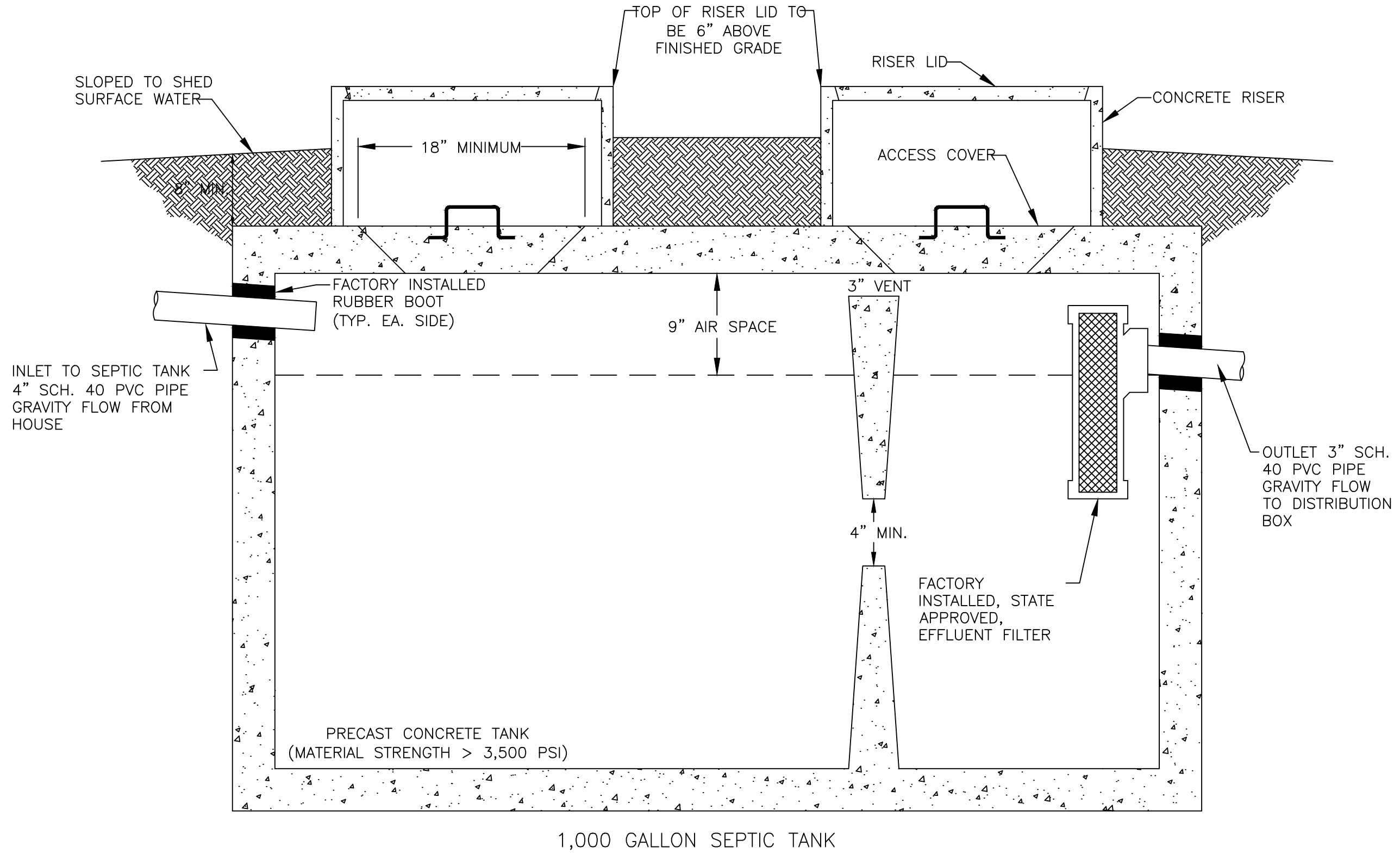

**SEPTIC TANK DETAIL**  
N.T.S.

<b>SHEET NUMBER</b>		<b>4 of 5</b>	
PREPARED FOR : LCI Homes 5511 Capital Center Drive Suite 560 Raleigh, NC 27612		Boone Trail Village Lot 49 Septic Tank Detail	
REVISION NO.	DATE	REVISION NO.	DATE
Original Submittal	February 4, 2025	Revision 1	---
Revision 1	---	Revision 2	---
Revision 2	---	Revision 3	---
Revision 3	---	Master Set	---
DESIGNER CONTACT:	ADAM AYCOCK, EI	DRAWN BY:	ADAM AYCOCK, EI
DATE :	February 4, 2025		
<b>MITCHELL ENVIRONMENTAL, PA</b> <b>C-2917</b> <b>1501 LAKESTONE VILLAGE LANE</b> <b>SUITE 205</b> <b>FUQUAY VARINA, NC 27526</b>			

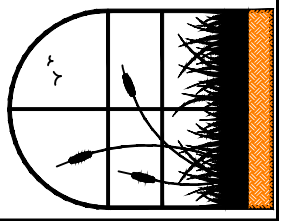



# NITRIFICATION TRENCH DETAIL FOR EZ-FLOW

N.T.S.

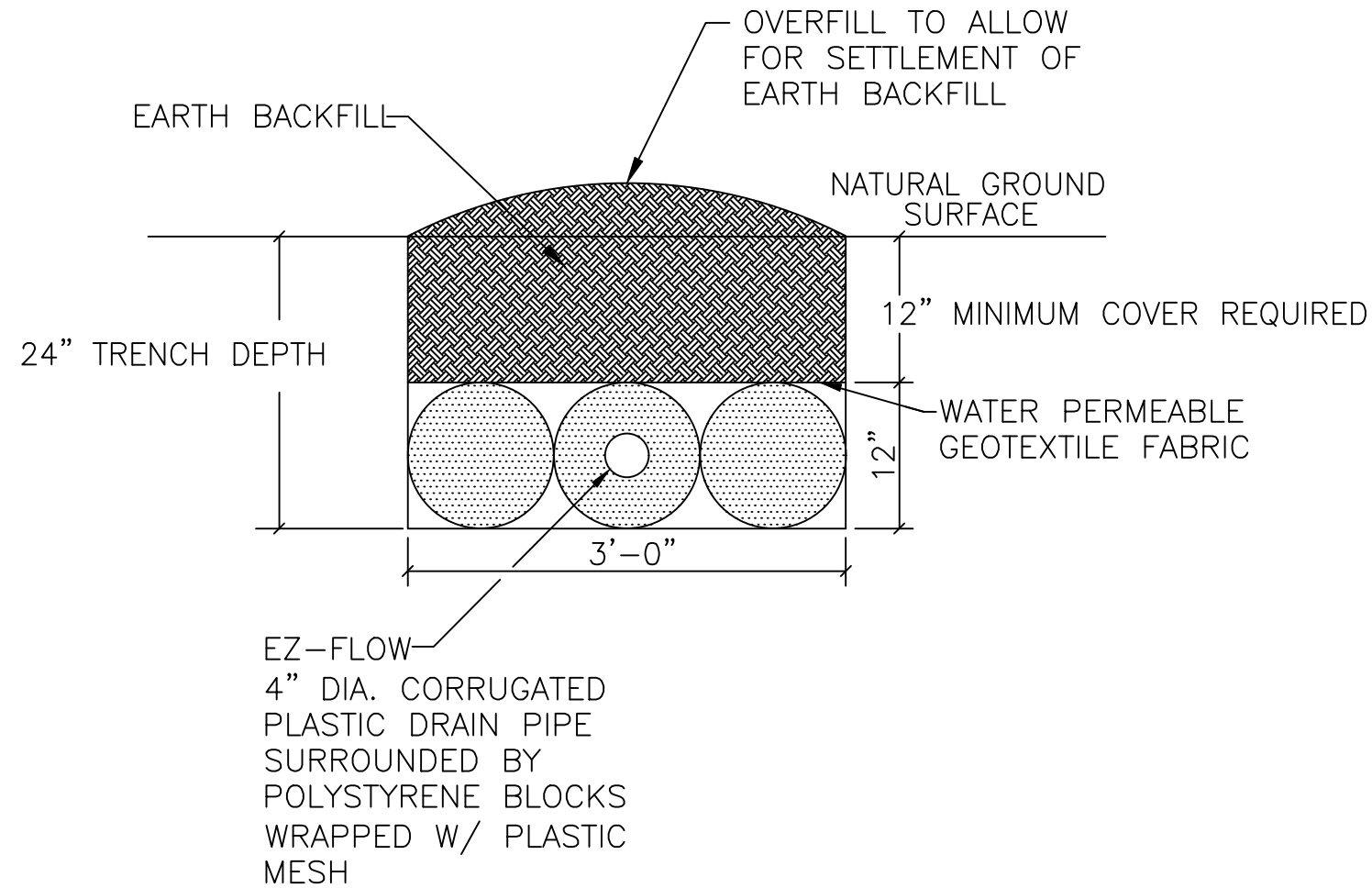

**NOTES:**

1. PERFORATED CORRUGATED PLASTIC PIPE SHALL MEET REQUIREMENTS OF ASTM D 2729.
2. PIPE SHALL BE LEVEL.
3. ENDCAP SHALL BE PROVIDED AT END OF ALL CORRUGATED PLASTIC PIPE LINES.
4. TRENCH BOTTOM SHALL BE LEVEL.
5. HAND RAKE TRENCH WALLS PRIOR TO PLACEMENT OF TRENCH MEDIA IF SOIL SMEARING IS PRESENT.

<b>SHEET NUMBER</b>	<b>5 of 5</b>
<i>Boone Trail Village Lot 49 Trench Detail</i>	

REVISION NO.	DATE
Original Submittal	February 4, 2025
Revision 1	-----
Revision 2	-----
Revision 3	-----
Master Set	-----

LCI Homes PREPARED FOR : 5511 Capital Center Drive Suite 560 Raleigh, NC 27612	DATE : February 4, 2025 DESIGNER CONTACT: ADAM AYCOCK, EI DRAWN BY: ADAM AYCOCK, EI
---	---

**MITCHELL ENVIRONMENTAL, PA**  
C-2917

**1501 LAKESTONE VILLAGE LANE**  
SUITE 205  
FUQUAY VARINA, NC 27526