

**ENERGY COMPLIANCE**  
 ZONE 3A = MAX. GLAZING U-FACTOR .35  
 R-VALUE = CEILING R30, WALLS R13,  
 FLOORS R19  
 ZONE 4A = MAX. GLAZING U-FACTOR .35  
 R-VALUE = CEILING R38, WALLS R15,  
 FLOORS R19

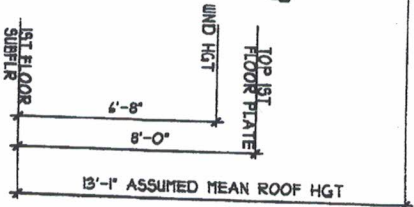

	<b>H SQUARED HOME DESIGN, INC.</b> 185 HEATHERSTONE CT BENSON NC 27504 (919) 237-1408	<b>DESIGNED BY:</b> HEATHER HALL 185 HEATHERSTONE CT BENSON NC 27504 (919) 237-1408	<b>SQUARE FOOTAGE:</b> FIRST FLOOR = 1270 FRONT PORCH = 240 REAR PORCH = 50	<b>HEATED FOOTAGE:</b> <b>#1270</b>	<b>THE CHARLESTON</b>
	<b>DATE:</b> 01/28/2020	<b>STORY:</b> 1 STORY	<b>TEL:</b> 0109120		

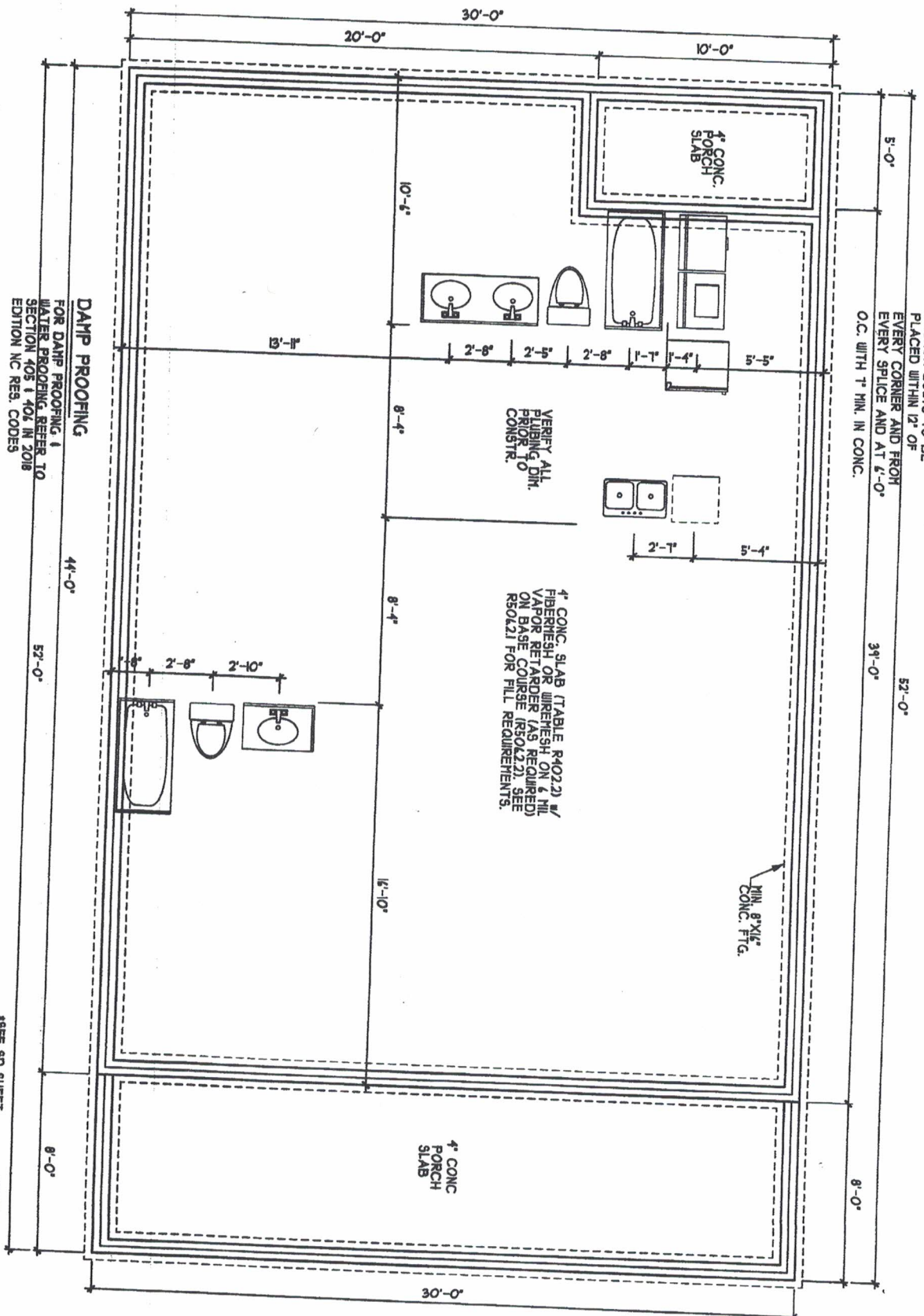

ANCHOR BOLTS

ANCHOR BOLTS TO BE PLACED WITHIN 12" OF EVERY CORNER AND FROM EVERY SPICE AND AT 4'-0" O.C. WITH 1" MIN. IN CONC.

VERIFY ALL PLUMBING DIM. CONSTR.

4" CONC. SLAB (TABLE P402.2) w/ FIBERESH OR WIREESH ON 1" VAPOR RETARDER (AS REQUIRED) ON BASE COURSE (R504.2). SEE R504.2.1 FOR FILL REQUIREMENTS.

MIN. 8"x12" CONC. FIG.

DAMP PROOFING

FOR DAMP PROOFING, 1 WATER PROOFING, REFER TO SECTION 405 & 402 IN 2018 EDITION NC RES. CODES

\*SEE 30 SHEET FOR NOTES & DETAILS

STEEL WALL FOUNDATION PLAN SCALE 1/4" = 1'-0"

	<b>H SQUARED HOME DESIGN, INC.</b>	DESIGNED BY: HEATHER HALL 185 HEATHERSTONE CT BENSON NC 27504 919 237-1408	SQUARE FOOTAGE: FRONT FLOOR = 1270 FRONT PORCH = 240 REAR PORCH = 50	SHEET NO.: <b>#1270</b>	<b>THE CHARLESTON</b>
	DATE: 07/24/2020	FLOOR: 1 STORY	NO.: 0104920		

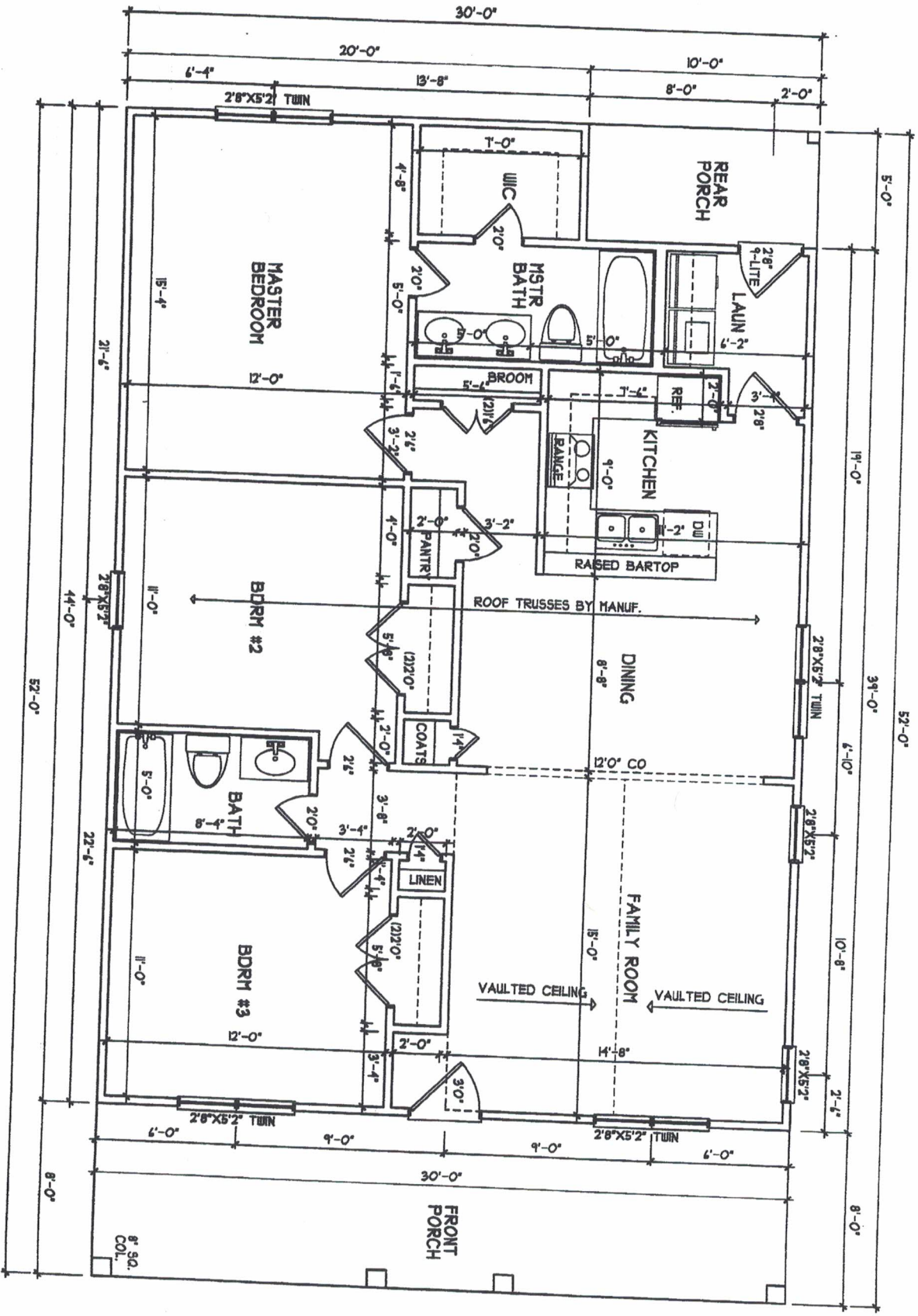

FIRST FLOOR PLAN  
SCALE 1/4" = 1'-0"

 <b>H SQUARED HOME DESIGN, INC.</b>	DESIGNED BY: HEATHER HALL 185 HEATHERSTONE CT RENDON NC 27804 800 207-1405	SQUARE FOOTAGE: FIRST FLOOR = 1270 FRONT PORCH = 240 REAR PORCH = 50	#1270	<b>THE CHARLESTON</b>
	DATE: 01/28/2009 1 STORY 0101920			

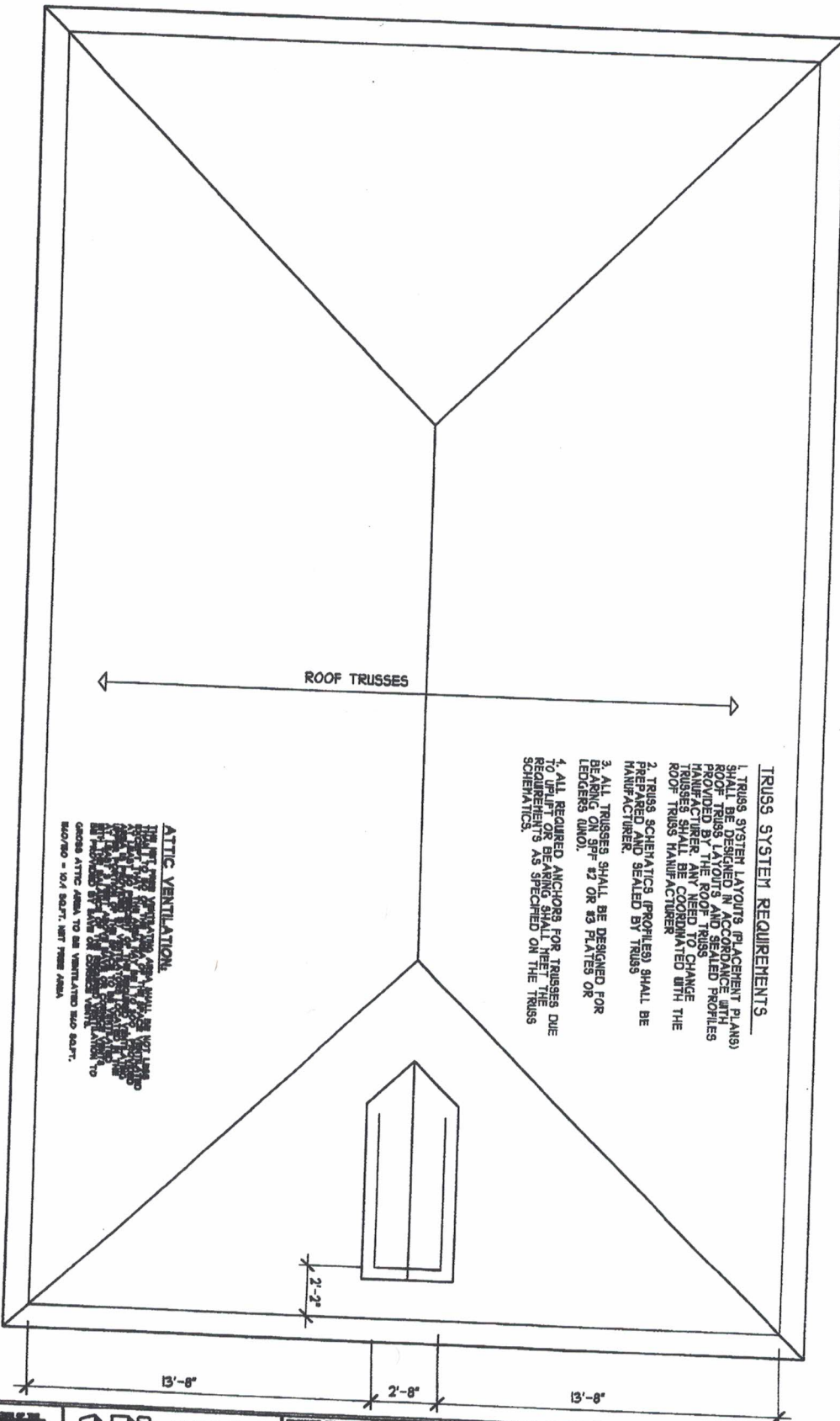

**TRUSS SYSTEM REQUIREMENTS**

1. TRUSS SYSTEM LAYOUTS (PLACEMENT PLANS) SHALL BE DESIGNED IN ACCORDANCE WITH ROOF TRUSS LAYOUTS AND SPACED PROFILES PROVIDED BY THE ROOF TRUSS MANUFACTURER. ANY NEED TO CHANGE ROOF TRUSS MANUFACTURER SHALL BE COORDINATED WITH THE ROOF TRUSS MANUFACTURER.
2. TRUSS SCHEMATICS (PROFILES) SHALL BE PREPARED AND SEALED BY TRUSS MANUFACTURER.
3. ALL TRUSSES SHALL BE DESIGNED FOR BEARING ON SP- 47 OR 43 PLATES OR LEMGERS (MIN).
4. ALL REQUIRED ANCHORS FOR TRUSSES DUE TO UPLIFT OR BEARING SHALL MEET THE REQUIREMENTS AS SPECIFIED ON THE TRUSS SCHEMATICS.

**ATTIC VENTILATION**

ALL ATTIC AREAS SHALL BE VENTILATED TO MEET THE REQUIREMENTS OF THE INTERNATIONAL RESIDENTIAL CODE BOARDS (IRC) AND THE INTERNATIONAL BUILDING CODE (IBC). ALL ATTIC AREAS SHALL BE VENTILATED TO MEET THE REQUIREMENTS OF THE INTERNATIONAL RESIDENTIAL CODE BOARDS (IRC) AND THE INTERNATIONAL BUILDING CODE (IBC). ALL ATTIC AREAS SHALL BE VENTILATED TO MEET THE REQUIREMENTS OF THE INTERNATIONAL RESIDENTIAL CODE BOARDS (IRC) AND THE INTERNATIONAL BUILDING CODE (IBC).

**ROOF PLAN**  
SCALE 1/4" = 1'-0"

<p><b>H SQUARED HOME DESIGN, INC.</b></p>	<p>DESIGNED BY: HEATHER HALL 185 HEATHERSTONE CT REHOBOTH BEACH, FL 33445 954 207-1408</p>	<p>SQUARE FOOTAGE:</p> <p>FIRST FLOOR = 1270 FRONT PORCH = 240 REAR PORCH = 50</p>	<p>FINISHED FOOTAGE:</p> <p><b>#1270</b></p>	<p><b>THE CHARLESTON</b></p>
	<p>DATE: 04/28/2020</p> <p>STORY: 1 STORY</p> <p>NO: 010920</p>			





Trenco  
818 Soundside Rd  
Edenton, NC 27932

Re: 24120078-01  
Coats-Charleston 1270-Roof-Charleston 1270 VFR

The truss drawing(s) referenced below have been prepared by Truss Engineering Co. under my direct supervision based on the parameters provided by Carter Components (Sanford, NC)).

Pages or sheets covered by this seal: I71239836 thru I71239851

My license renewal date for the state of North Carolina is December 31, 2025.

North Carolina COA: C-0844



February 7, 2025

Gilbert, Eric

**IMPORTANT NOTE:** The seal on these truss component designs is a certification that the engineer named is licensed in the jurisdiction(s) identified and that the designs comply with ANSI/TPI 1. These designs are based upon parameters shown (e.g., loads, supports, dimensions, shapes and design codes), which were given to MiTek or TRENCO. Any project specific information included is for MiTek's or TRENCO's customers file reference purpose only, and was not taken into account in the preparation of these designs. MiTek or TRENCO has not independently verified the applicability of the design parameters or the designs for any particular building. Before use, the building designer should verify applicability of design parameters and properly incorporate these designs into the overall building design per ANSI/TPI 1, Chapter 2.

Job 24120078-01	Truss A1-2	Truss Type Hip Girder	Qty 2	Ply 2	Coats-Charleston 1270-Roof-Charleston 1270 VFR 171239836
Carter Components (Sanford, NC), Sanford, NC - 27332,					Job Reference (optional)

Run: 8:73 S Dec 5 2024 Print: 8:730 S Dec 5 2024 MiTek Industries, Inc. Wed Feb 05 13:37:00 Page: 1  
 ID: r6htGdpMx6S3CSekV76vy9ZmB-RfC?PsB70Hq3NSgPqnL6w3ulTXbGKwRCDoi7J4zJC?r

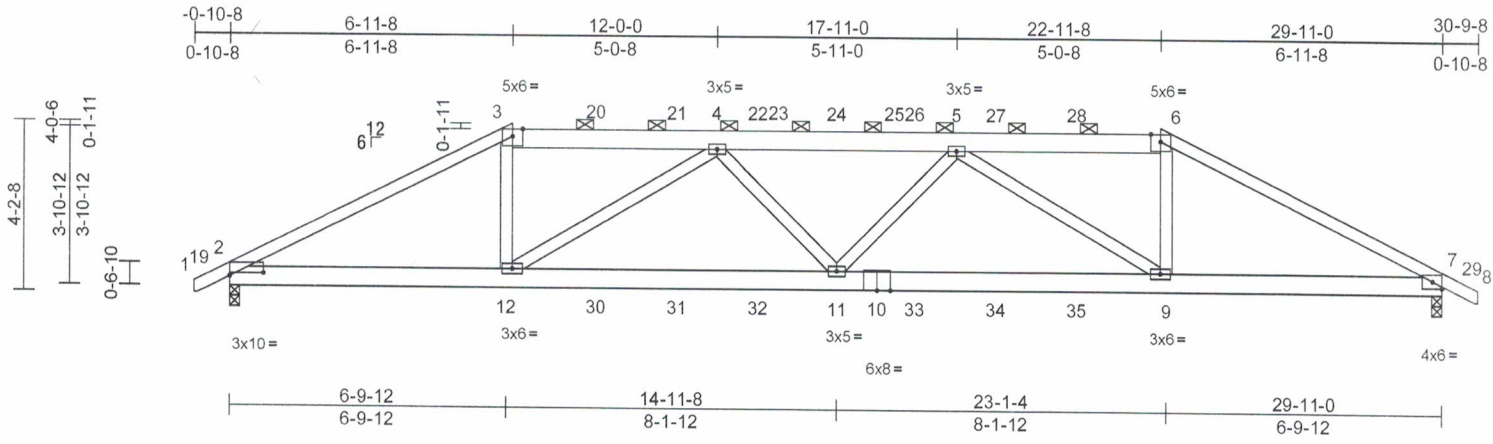

Scale = 1:56.5  
 Plate Offsets (X, Y): [2:0-10-0,0-0-14]

Loading	(psf)	Spacing	2-0-0	CSI	DEFL	in (loc)	l/defl	L/d	PLATES	GRIP		
TCLL (roof)	20.0	Plate Grip DOL	1.15	TC	0.82	Vert(LL)	-0.20	9-11	>999	240	MT20	244/190
Snow (Pf/Pg)	18.9/20.0	Lumber DOL	1.15	BC	0.97	Vert(CT)	-0.38	9-11	>938	180		
TCDL	10.0	Rep Stress Incr	NO	WB	0.52	Horz(CT)	0.08	7	n/a	n/a		
BCLL	0.0*	Code	IRC2021/TPI2014	Matrix-MSH								
BCDL	10.0											
											Weight: 347 lb	FT = 20%

- LUMBER**
- TOP CHORD 2x4 SP No.2 \*Except\* 3-6:2x6 SP No.2  
 BOT CHORD 2x6 SP 2400F 2.0E \*Except\* 10-7:2x6 SP No.2  
 WEBS 2x4 SP No.3
- BRACING**
- TOP CHORD Structural wood sheathing directly applied or 3-11-0 oc purlins, except 2-0-0 oc purlins (5-1-2 max.); 3-6.  
 BOT CHORD Rigid ceiling directly applied or 10-0-0 oc bracing.
- REACTIONS** (size) 2=0-3-0, 7=0-3-0  
 Max Horiz 2=-39 (LC 9)  
 Max Grav 2=3157 (LC 36), 7=3157 (LC 36)
- FORCES** (lb) - Maximum Compression/Maximum Tension
- TOP CHORD 1-2=0/32, 2-3=-6099/0, 3-4=-5321/0, 4-5=-8177/0, 5-6=-5331/0, 6-7=-6114/0, 7-8=0/32  
 BOT CHORD 2-12=0/5413, 11-12=0/7601, 9-11=0/7598, 7-9=0/5424  
 WEBS 3-12=0/2496, 6-9=0/2506, 4-11=0/914, 4-12=-2746/0, 5-11=0/918, 5-9=-2730/0
- Unbalanced roof live loads have been considered for this design.
  - Wind: ASCE 7-16; Vult=130mph (3-second gust) Vasd=103mph; TC DL=6.0psf; BCDL=6.0psf; h=25ft; Cat. II; Exp B; Enclosed; MWFRS (envelope); cantilever left and right exposed; end vertical left and right exposed; Lumber DOL=1.60 plate grip DOL=1.33
  - TCLL: ASCE 7-16; Pr=20.0 psf (roof LL: Lum DOL=1.15 Plate DOL=1.15); Pg=20.0 psf; Pf=18.9 psf (Lum DOL=1.15 Plate DOL=1.15); Is=1.0; Rough Cat B; Fully Exp.; Ce=0.9; Cs=1.00; Ct=1.10, Lu=50-0-0
  - Unbalanced snow loads have been considered for this design.
  - This truss has been designed for greater of min roof live load of 12.0 psf or 2.00 times flat roof load of 13.9 psf on overhangs non-concurrent with other live loads.
  - Provide adequate drainage to prevent water ponding.
  - \* This truss has been designed for a live load of 20.0psf on the bottom chord in all areas where a rectangle 3-06-00 tall by 2-00-00 wide will fit between the bottom chord and any other members.
  - Bearings are assumed to be: Joint 2 SP 2400F 2.0E, Joint 7 SP No.2.
  - Graphical purlin representation does not depict the size or the orientation of the purlin along the top and/or bottom chord.
  - Hanger(s) or other connection device(s) shall be provided sufficient to support concentrated load(s) 81 lb down and 36 lb up at 6-11-8, 81 lb down and 34 lb up at 9-0-4, 81 lb down and 34 lb up at 11-0-4, 162 lb down at 13-0-4, 162 lb down at 14-11-8, 162 lb down at 16-10-12, 81 lb down and 34 lb up at 18-10-12, and 81 lb down and 34 lb up at 20-10-12, and 81 lb down and 36 lb up at 22-11-8 on top chord, and 728 lb down at 6-11-8, 190 lb down at 9-0-4, 190 lb down at 11-0-4, 270 lb down at 13-0-4, 270 lb down at 14-11-8, 270 lb down at 16-10-12, 190 lb down at 18-10-12, and 190 lb down at 20-10-12, and 728 lb down at 22-10-12 on bottom chord. The design/selection of such connection device(s) is the responsibility of others.

**LOAD CASE(S)** Standard

- Dead + Snow (balanced): Lumber Increase=1.15, Plate Increase=1.15  
 Uniform Loads (lb/ft)  
 Vert: 1-3=48, 3-6=58, 6-8=48, 13-16=20  
 Concentrated Loads (lb)

- NOTES**
- 2-ply truss to be connected together with 10d (0.131"x3") nails as follows:  
 Top chords connected as follows: 2x4 - 1 row at 0-9-0 oc, 2x6 - 2 rows staggered at 0-9-0 oc.  
 Bottom chords connected as follows: 2x6 - 2 rows staggered at 0-9-0 oc.  
 Web connected as follows: 2x4 - 1 row at 0-9-0 oc.
  - All loads are considered equally applied to all plies, except if noted as front (F) or back (B) face in the LOAD CASE(S) section. Ply to ply connections have been provided to distribute only loads noted as (F) or (B), unless otherwise indicated.





Job 24120078-01	Truss A1-2	Truss Type Hip Girder	Qty 2	Ply <b>2</b>	Coats-Charleston 1270-Roof-Charleston 1270 VFR I71239836 Job Reference (optional)
--------------------	---------------	--------------------------	----------	-----------------	---

Carter Components (Sanford, NC), Sanford, NC - 27332,

Run: 8.73 S Dec 5 2024 Print: 8.730 S Dec 5 2024 MiTek Industries, Inc. Wed Feb 05 13:37:00  
ID:r6hhtGdpMkx6S3CSeKv76vy9ZmB-RfC?PsB70Hq3NSgPqnL8w3ulTXbGKwRCDoi7J4zJC7f

Page: 2

Vert: 3=-57 (B), 6=-57 (B), 12=-728 (B), 9=-728 (B),  
11=-270 (B), 20=-52 (B), 21=-52 (B), 22=-132 (B),  
24=-132 (B), 26=-132 (B), 27=-52 (B), 28=-52 (B),  
30=-190 (B), 31=-190 (B), 32=-270 (B), 33=-270 (B),  
34=-190 (B), 35=-190 (B)

**WARNING** - Verify design parameters and READ NOTES ON THIS AND INCLUDED MITEK REFERENCE PAGE Mill-7473 rev. 1/2/2023 BEFORE USE

Design valid for use only with MiTek® connectors. This design is based only upon parameters shown, and is for an individual building component, not a truss system. Before use, the building designer must verify the applicability of design parameters and properly incorporate this design into the overall building design. Bracing indicated is to prevent buckling of individual truss web and/or chord members only. Additional temporary and permanent bracing is always required for stability and to prevent collapse with possible personal injury and property damage. For general guidance regarding the fabrication, storage, delivery, erection and bracing of trusses and truss systems, see **ANSI/TPI1 Quality Criteria and DSB-22** available from Truss Plate Institute ([www.tpinst.org](http://www.tpinst.org)) and **BCSI Building Component Safety Information** available from the Structural Building Component Association ([www.sbcacomponents.com](http://www.sbcacomponents.com))

ENGINEERING BY  
**TRENCO**  
A MiTek Affiliate

818 Soundside Road  
Edenton, NC 27932

Job 24120078-01	Truss A2	Truss Type Hip	Qty 1	Ply 1	Coats-Charleston 1270-Roof-Charleston 1270 VFR 171239837
Carter Components (Sanford, NC), Sanford, NC - 27332,					Job Reference (optional)

Carter Components (Sanford, NC), Sanford, NC - 27332,

Run: 8.73 S Dec 5 2024 Print: 8.730 S Dec 5 2024 MiTek Industries, Inc. Wed Feb 05 13:37:01  
ID:fByFs3twzh7v0XSX0jObcay9Zn9-RfC?PsB70Hq3NSgPqnL8w3uITXbGKwRcDol7J4zJC?r

Page: 1

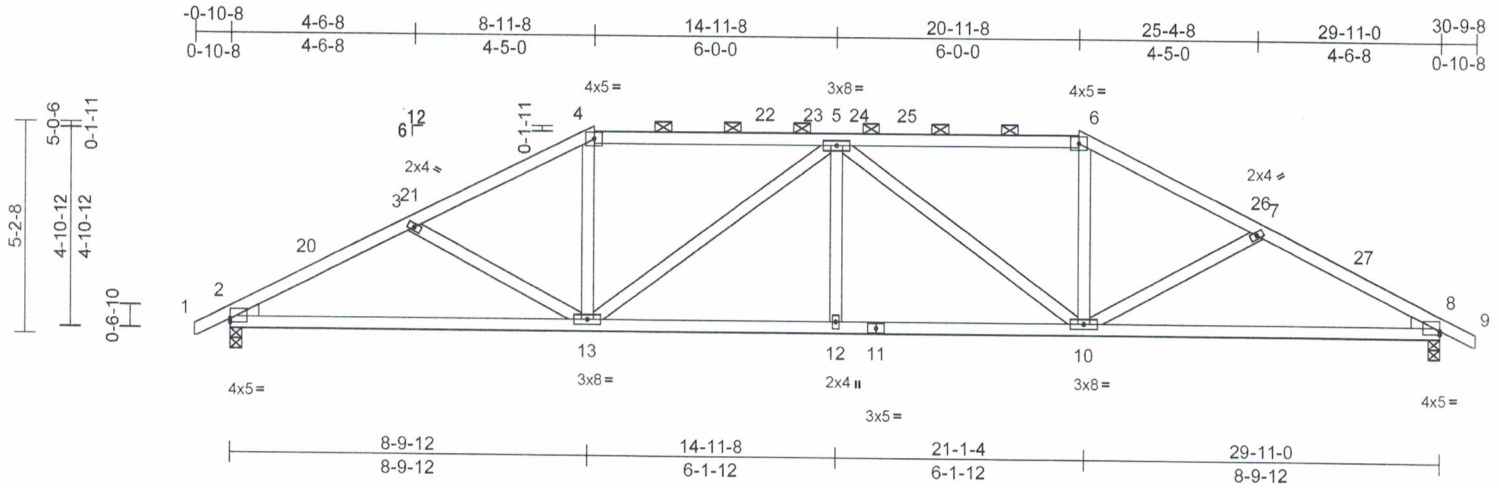

Scale = 1:56.6

Plate Offsets (X, Y): [2:Edge,0-1-2], [8:Edge,0-1-2]

Loading	(psf)	Spacing	2-0-0	CSI	DEFL	in	(loc)	l/defl	L/d	PLATES	GRIP	
TCLL (roof)	20.0	Plate Grip DOL	1.15	TC	0.72	Vert(LL)	-0.13	12-13	>999	240	MT20	244/190
Snow (Pf/Pg)	18.9/20.0	Lumber DOL	1.15	BC	0.84	Vert(CT)	-0.25	12-13	>999	180		
TCDL	10.0	Rep Stress Incr	YES	WB	0.67	Horz(CT)	0.09	8	n/a	n/a		
BCLL	0.0*	Code	IRC2021/TPI2014	Matrix-MSH								
BCDL	10.0											
											Weight: 153 lb	FT = 20%

**LUMBER**  
TOP CHORD 2x4 SP No.2  
BOT CHORD 2x4 SP No.2  
WEBS 2x4 SP No.3  
WEDGE Left: 2x4 SP No.3  
Right: 2x4 SP No.3

**BRACING**  
TOP CHORD Structural wood sheathing directly applied or 3-6-1 oc purlins, except 2-0-0 oc purlins (3-8-8 max.): 4-6.  
BOT CHORD Rigid ceiling directly applied or 10-0-0 oc bracing.

**REACTIONS** (size) 2=0-3-8, 8=0-3-8  
Max Horiz 2=-49 (LC 13)  
Max Grav 2=1296 (LC 44), 8=1296 (LC 44)

**FORCES** (lb) - Maximum Compression/Maximum Tension  
TOP CHORD 1-2=0/32, 2-3=-2124/236, 3-4=-1904/196, 4-5=-1677/203, 5-6=-1677/203, 6-7=-1904/196, 7-8=-2124/236, 8-9=0/32  
BOT CHORD 2-13=-144/1830, 12-13=-98/2125, 10-12=-98/2125, 8-10=-153/1831  
WEBS 3-13=-351/113, 4-13=0/521, 5-13=-607/60, 5-12=0/117, 5-10=-607/60, 6-10=0/521, 7-10=-351/113

- Wind: ASCE 7-16; Vult=130mph (3-second gust) Vasd=103mph; TCDL=6.0psf; BCDL=6.0psf; h=25ft; Cat. II; Exp B; Enclosed; MWFRS (envelope) and C-C Exterior(2E) -0-10-1 to 2-1-15, Interior (1) 2-1-15 to 8-11-8, Exterior(2R) 8-11-8 to 13-2-7, Interior (1) 13-2-7 to 20-11-8, Exterior(2R) 20-11-8 to 25-2-7, Interior (1) 25-2-7 to 30-9-1 zone; cantilever left and right exposed; end vertical left and right exposed; C-C for members and forces & MWFRS for reactions shown; Lumber DOL=1.60 plate grip DOL=1.33
- TCLL: ASCE 7-16; Pr=20.0 psf (roof LL: Lum DOL=1.15 Plate DOL=1.15); Pg=20.0 psf; Pf=18.9 psf (Lum DOL=1.15 Plate DOL=1.15); Is=1.0; Rough Cat B; Fully Exp.; Ce=0.9; Cs=1.00; Ct=1.10, Lu=50-0-0
- Unbalanced snow loads have been considered for this design.
- This truss has been designed for greater of min roof live load of 12.0 psf or 2.00 times flat roof load of 13.9 psf on overhangs non-concurrent with other live loads.
- Provide adequate drainage to prevent water ponding.
- \* This truss has been designed for a live load of 20.0psf on the bottom chord in all areas where a rectangle 3-06-00 tall by 2-00-00 wide will fit between the bottom chord and any other members.
- All bearings are assumed to be SP No.2.
- Graphical purlin representation does not depict the size or the orientation of the purlin along the top and/or bottom chord.

LOAD CASE(S) Standard

**NOTES**  
1) Unbalanced roof live loads have been considered for this design.

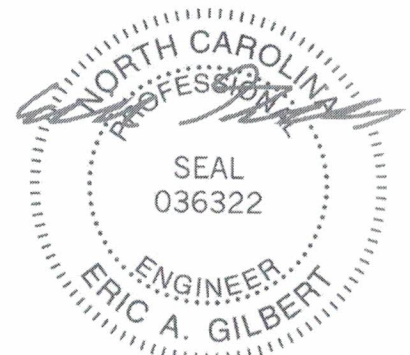

February 7, 2025

**WARNING** - Verify design parameters and READ NOTES ON THIS AND INCLUDED MITEK REFERENCE PAGE MII-7473 rev. 1/2/2023 BEFORE USE  
Design valid for use only with MiTek® connectors. This design is based only upon parameters shown, and is for an individual building component, not a truss system. Before use, the building designer must verify the applicability of design parameters and properly incorporate this design into the overall building design. Bracing indicated is to prevent buckling of individual truss web and/or chord members only. Additional temporary and permanent bracing is always required for stability and to prevent collapse with possible personal injury and property damage. For general guidance regarding the fabrication, storage, delivery, erection and bracing of trusses and truss systems, see ANSI/TPI1 Quality Criteria and DSB-22 available from Truss Plate Institute (www.tpinst.org) and BCSI Building Component Safety Information available from the Structural Building Component Association (www.sbccomponents.com)

ENGINEERING BY  
**TRENCO**  
A MiTek Affiliate

818 Soundside Road  
Edenton, NC 27932

Job	Truss	Truss Type	Qty	Ply	Coats-Charleston 1270-Roof-Charleston 1270 VFR
24120078-01	A3	Hip	1	1	Job Reference (optional) I71239838

Carter Components (Sanford, NC), Sanford, NC - 27332,

Run: 8.730 S Dec 5 2024 Print: 8.730 S Dec 5 2024 MITek Industries, Inc. Wed Feb 05 13:37:02  
 ID:EKkHgEdNgYckdTxhRw1uocy9ZnT-RfC?PsB70Hq3NSgPqnL8w3uITXbGKwRCDoi7J4zJC7f

Page: 1

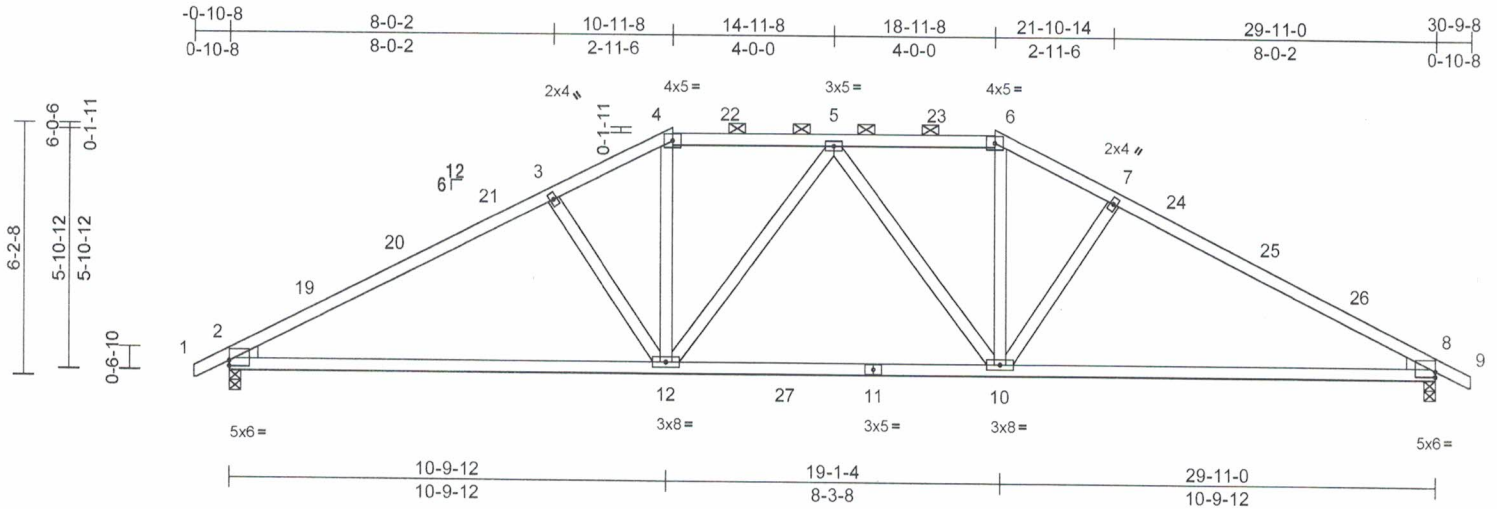

Scale = 1:56.8

Plate Offsets (X, Y): [2:Edge,0-1-10], [8:Edge,0-1-10]

Loading	(psf)	Spacing	2-0-0	CSI	DEFL	in	(loc)	l/defl	L/d	PLATES	GRIP
TCLL (roof)	20.0	Plate Grip DOL	1.15	TC	Vert(LL)	-0.25	10-15	>999	240	MT20	244/190
Snow (Pf/Pg)	18.9/20.0	Lumber DOL	1.15	BC	Vert(CT)	-0.53	10-15	>683	180		
TCDL	10.0	Rep Stress Incr	YES	WB	Horz(CT)	0.06	8	n/a	n/a		
BCLL	0.0*	Code	IRC2021/TPI2014	Matrix-MSH							
BCDL	10.0										
										Weight: 148 lb	FT = 20%

**LUMBER**

TOP CHORD 2x4 SP No.1 \*Except\* 4-6:2x4 SP No.2  
 BOT CHORD 2x4 SP No.1  
 WEBS 2x4 SP No.3  
 WEDGE Left: 2x4 SP No.3  
 Right: 2x4 SP No.3

**BRACING**

TOP CHORD Structural wood sheathing directly applied or  
 2-2-0 oc purlins, except  
 2-0-0 oc purlins (4-2-13 max.): 4-6.  
 BOT CHORD Rigid ceiling directly applied or 10-0-0 oc  
 bracing.

**REACTIONS** (size) 2=0-3-8, 8=0-3-8  
 Max Horiz 2=-59 (LC 13)  
 Max Grav 2=1450 (LC 50), 8=1450 (LC 50)

**FORCES** (lb) - Maximum Compression/Maximum  
 Tension

TOP CHORD 1-2=0/32, 2-3=-2490/225, 3-4=-2183/219,  
 4-5=-1869/203, 5-6=-1869/203,  
 6-7=-2182/219, 7-8=-2490/225, 8-9=0/32

BOT CHORD 2-12=-232/2106, 10-12=-60/1929,  
 8-10=-236/2107

WEBS 3-12=-494/149, 4-12=-57/866, 6-10=-57/866,  
 7-10=-494/149, 5-12=-296/71, 5-10=-296/71

- TCLL: ASCE 7-16; Pr=20.0 psf (roof LL: Lum DOL=1.15 Plate DOL=1.15); Pg=20.0 psf; Pf=18.9 psf (Lum DOL=1.15 Plate DOL=1.15); Is=1.0; Rough Cat B; Fully Exp.; Ce=0.9; Cs=1.00; Ct=1.10, Lu=50-0-0
- Unbalanced snow loads have been considered for this design.
- This truss has been designed for greater of min roof live load of 12.0 psf or 2.00 times flat roof load of 13.9 psf on overhangs non-concurrent with other live loads.
- Provide adequate drainage to prevent water ponding.
- \* This truss has been designed for a live load of 20.0psf on the bottom chord in all areas where a rectangle 3-06-00 tall by 2-00-00 wide will fit between the bottom chord and any other members, with BCDL = 10.0psf.
- All bearings are assumed to be SP No.1.
- Graphical purlin representation does not depict the size or the orientation of the purlin along the top and/or bottom chord.

**LOAD CASE(S)** Standard

- NOTES**
- Unbalanced roof live loads have been considered for this design.
  - Wind: ASCE 7-16; Vult=130mph (3-second gust)  
 Vasd=103mph; TCCL=6.0psf; BCDL=6.0psf; h=25ft; Cat. II; Exp B; Enclosed; MWFRS (envelope) and C-C Exterior(2E) 0-10-1 to 2-1-15, Interior (1) 2-1-15 to 10-11-8, Exterior(2R) 10-11-8 to 14-11-8, Interior (1) 14-11-8 to 18-11-8, Exterior(2R) 18-11-8 to 23-2-7, Interior (1) 23-2-7 to 30-9-1 zone; cantilever left and right exposed; end vertical left and right exposed; C-C for members and forces & MWFRS for reactions shown; Lumber DOL=1.60 plate grip DOL=1.33



February 7, 2025

**WARNING** - Verify design parameters and READ NOTES ON THIS AND INCLUDED MITEK REFERENCE PAGE MII-7473 rev. 1/2/2023 BEFORE USE  
 Design valid for use only with MITek® connectors. This design is based only upon parameters shown, and is for an individual building component, not a truss system. Before use, the building designer must verify the applicability of design parameters and properly incorporate this design into the overall building design. Bracing indicated is to prevent buckling of individual truss web and/or chord members only. Additional temporary and permanent bracing is always required for stability and to prevent collapse with possible personal injury and property damage. For general guidance regarding the fabrication, storage, delivery, erection and bracing of trusses and truss systems, see ANSI/TPI1 Quality Criteria and DSB-22 available from Truss Plate Institute (www.tpinst.org) and BCSI Building Component Safety Information available from the Structural Building Component Association (www.sbcacomponents.com)

**ENGINEERING BY**  
**TRENCO**  
 A MITek Affiliate

818 Soundside Road  
 Edenton, NC 27932

Job 24120078-01	Truss A4	Truss Type Hip	Qty 1	Ply 1	Coats-Charleston 1270-Roof-Charleston 1270 VFR 171239839
Carter Components (Sanford, NC), Sanford, NC - 27332.					Job Reference (optional)

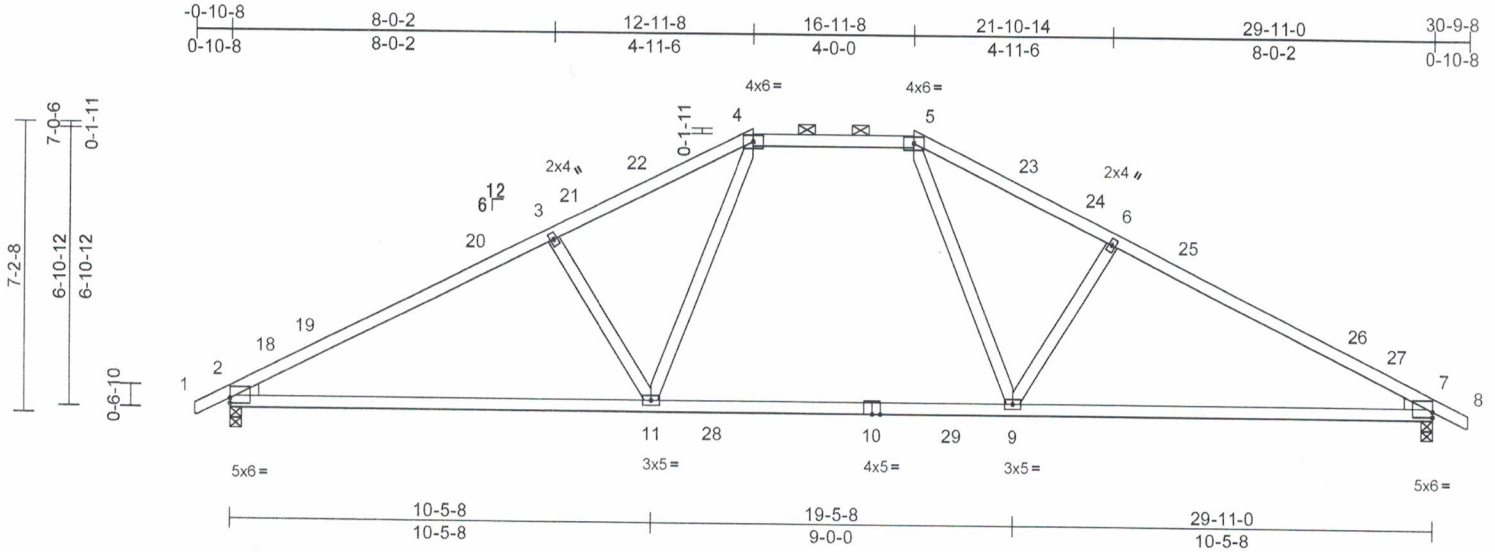

Scale = 1:57

Plate Offsets (X, Y): [2:Edge,0-1-10], [7:Edge,0-1-10]

Loading	(psf)	Spacing	2-0-0	CSI	DEFL	in	(loc)	l/defl	L/d	PLATES	GRIP
TCLL (roof)	20.0	Plate Grip DOL	1.15	TC	Vert(LL)	-0.34	9-14	>999	240	MT20	244/190
Snow (Pf/Pg)	18.9/20.0	Lumber DOL	1.15	BC	Vert(CT)	-0.55	9-14	>654	180		
TCDL	10.0	Rep Stress Incr	YES	WB	Horz(CT)	0.07	7	n/a	n/a		
BCLL	0.0*	Code	IRC2021/TPI2014	Matrix-MSH							
BCDL	10.0										
										Weight: 133 lb	FT = 20%

**LUMBER**

TOP CHORD 2x4 SP No.1 \*Except\* 4-5:2x4 SP No.2  
 BOT CHORD 2x4 SP No.1  
 WEBS 2x4 SP No.3  
 WEDGE Left: 2x4 SP No.3  
 Right: 2x4 SP No.3

**BRACING**

TOP CHORD Structural wood sheathing directly applied or  
 2-2-0 oc purlins, except  
 2-0-0 oc purlins (4-4-3 max.): 4-5.  
 BOT CHORD Rigid ceiling directly applied or 10-0-0 oc  
 bracing.

**REACTIONS** (size) 2=0-3-8, 7=0-3-8  
 Max Horiz 2=-70 (LC 13)  
 Max Grav 2=1507 (LC 50), 7=1507 (LC 50)

**FORCES** (lb) - Maximum Compression/Maximum  
 Tension

TOP CHORD 1-2=0/28, 2-3=-2731/222, 3-4=-2465/234,  
 4-5=-1829/226, 5-6=-2465/234,  
 6-7=-2731/222, 7-8=0/28

BOT CHORD 2-11=-224/2330, 9-11=-20/1764,  
 7-9=-216/2330

WEBS 3-11=-520/162, 4-11=-22/880, 5-9=-22/880,  
 6-9=-520/162

- TCLL: ASCE 7-16; Pr=20.0 psf (roof LL: Lum DOL=1.15 Plate DOL=1.15); Pg=20.0 psf; Pf=18.9 psf (Lum DOL=1.15 Plate DOL=1.15); Is=1.0; Rough Cat B; Fully Exp.; Ce=0.9; Cs=1.00; Ct=1.10, Lu=50-0-0
- Unbalanced snow loads have been considered for this design.
- This truss has been designed for greater of min roof live load of 12.0 psf or 2.00 times flat roof load of 13.9 psf on overhangs non-concurrent with other live loads.
- Provide adequate drainage to prevent water ponding.
- \* This truss has been designed for a live load of 20.0psf on the bottom chord in all areas where a rectangle 3-06-00 tall by 2-00-00 wide will fit between the bottom chord and any other members, with BCDL = 10.0psf.
- All bearings are assumed to be SP No.1.
- Graphical purlin representation does not depict the size or the orientation of the purlin along the top and/or bottom chord.

**LOAD CASE(S)** Standard

- NOTES**
- Unbalanced roof live loads have been considered for this design.
  - Wind: ASCE 7-16; Vult=130mph (3-second gust) Vasd=103mph; TC DL=6.0psf; BCDL=6.0psf; h=25ft; Cat. II; Exp B; Enclosed; MWFRS (envelope) and C-C Exterior(2E) -0-10-1 to 2-1-15, Interior (1) 2-1-15 to 12-11-8, Exterior(2E) 12-11-8 to 16-11-8, Exterior(2R) 16-11-8 to 21-2-7, Interior (1) 21-2-7 to 30-9-1 zone; cantilever left and right exposed; end vertical left and right exposed; C-C for members and forces & MWFRS for reactions shown; Lumber DOL=1.60 plate grip DOL=1.33



February 7, 2025



Job 24120078-01	Truss A6	Truss Type Roof Special	Qty 1	Ply 1	Coats-Charleston 1270-Roof-Charleston 1270 VFR Job Reference (optional) 171239841
--------------------	-------------	----------------------------	----------	----------	---

Carter Components (Sanford, NC), Sanford, NC - 27332,

Run: 8.73 S Dec 5 2024 Print: 8.730 S Dec 5 2024 MiTek Industries, Inc. Wed Feb 05 13:37:02  
ID:CAe9Cabl8TKSCFluuDtn\_y9a3b-RFC?PsB70Hq3NSgPqnL8w3ulTXbGKWRCDol7J4zJC?f

Page: 1

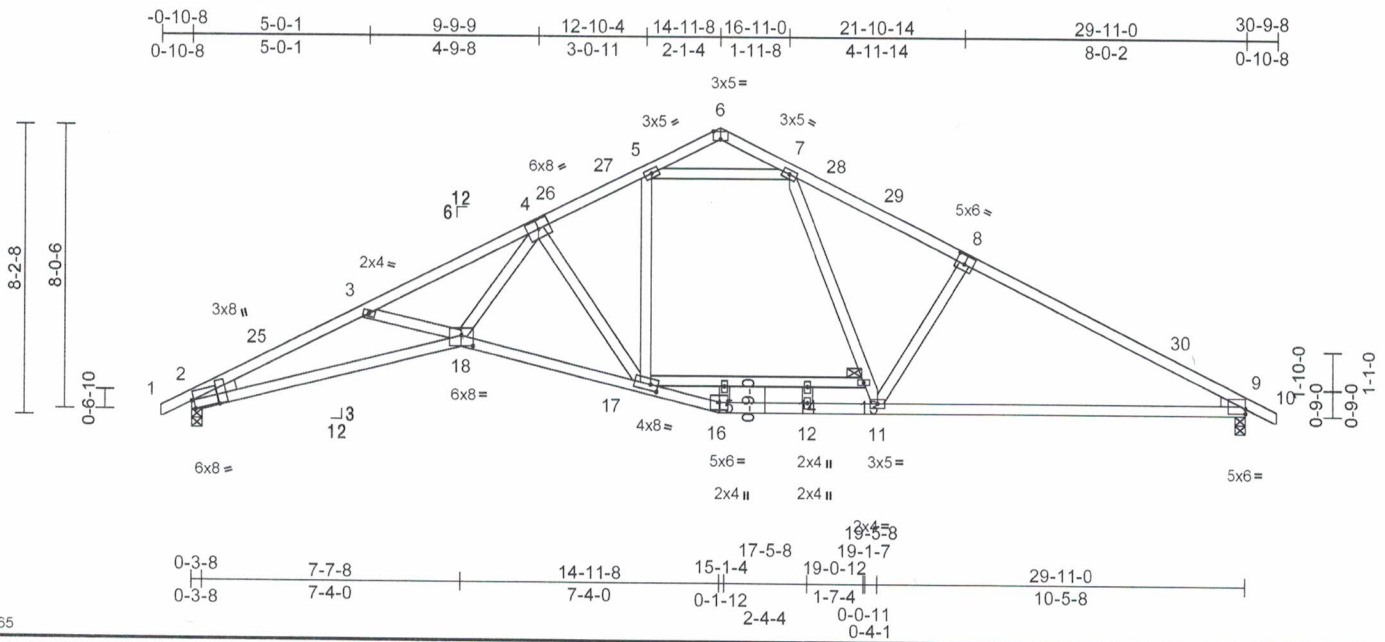

Scale = 1:65

Plate Offsets (X, Y): [2:0-0-12,Edge], [2:0-3-4,0-9-0], [6:0-2-8,Edge], [8:0-3-0,0-3-0], [9:Edge,0-1-10], [17:0-2-8,0-2-0], [18:0-4-0,0-3-8]

Loading	(psf)	Spacing		CSI		DEFL	in	(loc)	l/defl	L/d	PLATES	GRIP
TCLL (roof)	20.0	Plate Grip DOL	2-0-0	TC	0.92	Vert(LL)	-0.47	17-18	>762	240	MT20	244/190
Snow (Pf/Pg)	13.9/20.0	Lumber DOL	1.15	BC	0.93	Vert(CT)	-0.80	17-18	>449	180		
TCDL	10.0	Rep Stress Incr	YES	WB	0.96	Horz(CT)	0.26	9	n/a	n/a		
BCLL	0.0*	Code	IRC2021/TPI2014	Matrix-MSH								
BCDL	10.0											
											Weight: 161 lb	FT = 20%

**LUMBER**  
TOP CHORD 2x4 SP No.1 \*Except\* 6-8-8-10:2x4 SP No.2  
BOT CHORD 2x4 SP No.1 \*Except\* 2-18:2x4 SP 2400F 2.0E, 17-13:2x4 SP No.2  
WEBS 2x4 SP No.3 \*Except\* 7-11:2x4 SP No.2  
WEDGE Left: 2x4 SP No.3  
Right: 2x4 SP No.3

**BRACING**  
TOP CHORD Structural wood sheathing directly applied or 2-2-0 oc purlins.  
BOT CHORD Rigid ceiling directly applied or 10-0-0 oc bracing, Except:  
2-2-0 oc bracing: 9-11.

**REACTIONS** (size) 2=0-3-8, 9=0-3-8  
Max Horiz 2=81 (LC 14)  
Max Grav 2=1485 (LC 3), 9=1503 (LC 3)

**FORCES** (lb) - Maximum Compression/Maximum Tension  
TOP CHORD 1-2=0/28, 2-3=-4820/184, 3-5=-4694/143, 5-6=-163/45, 6-7=-302/48, 7-9=-2750/141, 9-10=0/28  
BOT CHORD 2-18=-101/4337, 17-18=0/3001, 16-17=0/1678, 12-16=0/1669, 11-12=0/1669, 9-11=-190/2357, 15-17=-15/330, 14-15=-17/295, 13-14=-17/295  
WEBS 3-18=-123/131, 4-18=0/2336, 4-17=-1668/88, 5-17=0/1095, 7-13=0/742, 11-13=-3/832, 5-7=-1816/138, 8-11=-399/160, 12-14=-151/0, 15-16=-199/5

**NOTES**  
1) Unbalanced roof live loads have been considered for this design.

- Wind: ASCE 7-16; Vult=130mph (3-second gust) Vasd=103mph; TCDL=6.0psf; BCDL=6.0psf; h=25ft; Cat. II; Exp B; Enclosed; MWFRS (envelope) and C-C Exterior(2E) -0-10-1 to 2-1-15, Interior (1) 2-1-15 to 14-11-8, Exterior(2R) 14-11-8 to 17-11-8, Interior (1) 17-11-8 to 30-9-1 zone; cantilever left and right exposed; end vertical left and right exposed; C-C for members and forces & MWFRS for reactions shown; Lumber DOL=1.60 plate grip DOL=1.33
- TCLL: ASCE 7-16; Pr=20.0 psf (roof LL: Lum DOL=1.15 Plate DOL=1.15); Pg=20.0 psf; Pf=13.9 psf (Lum DOL=1.15 Plate DOL=1.15); Is=1.0; Rough Cat B; Fully Exp.; Ce=0.9; Cs=1.00; Ct=1.10
- Unbalanced snow loads have been considered for this design.
- This truss has been designed for greater of min roof live load of 12.0 psf or 2.00 times flat roof load of 13.9 psf on overhangs non-concurrent with other live loads.
- \* This truss has been designed for a live load of 20.0psf on the bottom chord in all areas where a rectangle 3-06-00 tall by 2-00-00 wide will fit between the bottom chord and any other members, with BCDL = 10.0psf.
- Bearings are assumed to be: Joint 2 SP 2400F 2.0E, Joint 9 SP No.1
- Bearing at joint(s) 2 considers parallel to grain value using ANSI/TPI 1 angle to grain formula. Building designer should verify capacity of bearing surface.

**LOAD CASE(S)** Standard

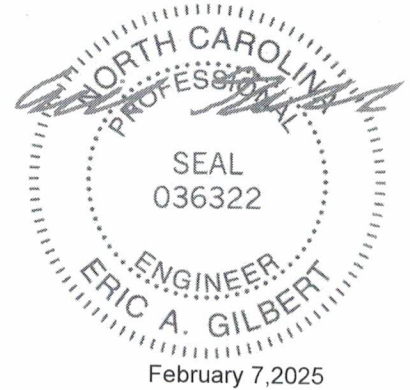

February 7, 2025

**WARNING** - Verify design parameters and READ NOTES ON THIS AND INCLUDED MITEK REFERENCE PAGE MIH-7473 rev. 1/2/2023 BEFORE USE  
Design valid for use only with MiTek® connectors. This design is based only upon parameters shown, and is for an individual building component, not a truss system. Before use, the building designer must verify the applicability of design parameters and properly incorporate this design into the overall building design. Bracing indicated is to prevent buckling of individual truss web and/or chord members only. Additional temporary and permanent bracing is always required for stability and to prevent collapse with possible personal injury and property damage. For general guidance regarding the fabrication, storage, delivery, erection and bracing of trusses and truss systems, see ANSI/TPI1 Quality Criteria and DSB-22 available from Truss Plate Institute (www.tpinst.org) and BCSI Building Component Safety Information available from the Structural Building Component Association (www.sbcacomponents.com)

ENGINEERING BY  
**TRENCO**  
A MiTek Affiliate

818 Soundside Road  
Edenton, NC 27932

Job 24120078-01	Truss A7	Truss Type Roof Special	Qty 4	Ply 1	Coats-Charleston 1270-Roof-Charleston 1270 VFR Job Reference (optional) I71239842
--------------------	-------------	----------------------------	----------	----------	---

Carter Components (Sanford, NC), Sanford, NC - 27332,

Run: 8.73 S Dec 5 2024 Print: 8.730 S Dec 5 2024 MiTek Industries, Inc. Wed Feb 05 13:37:02  
ID:CAe9Cabl8TKSCFluuDtn\_y9a3b-RFC?PsB70Hq3NSgPqnL8w3ulTXbGKWrcDoi7J4zJC?f

Page: 1

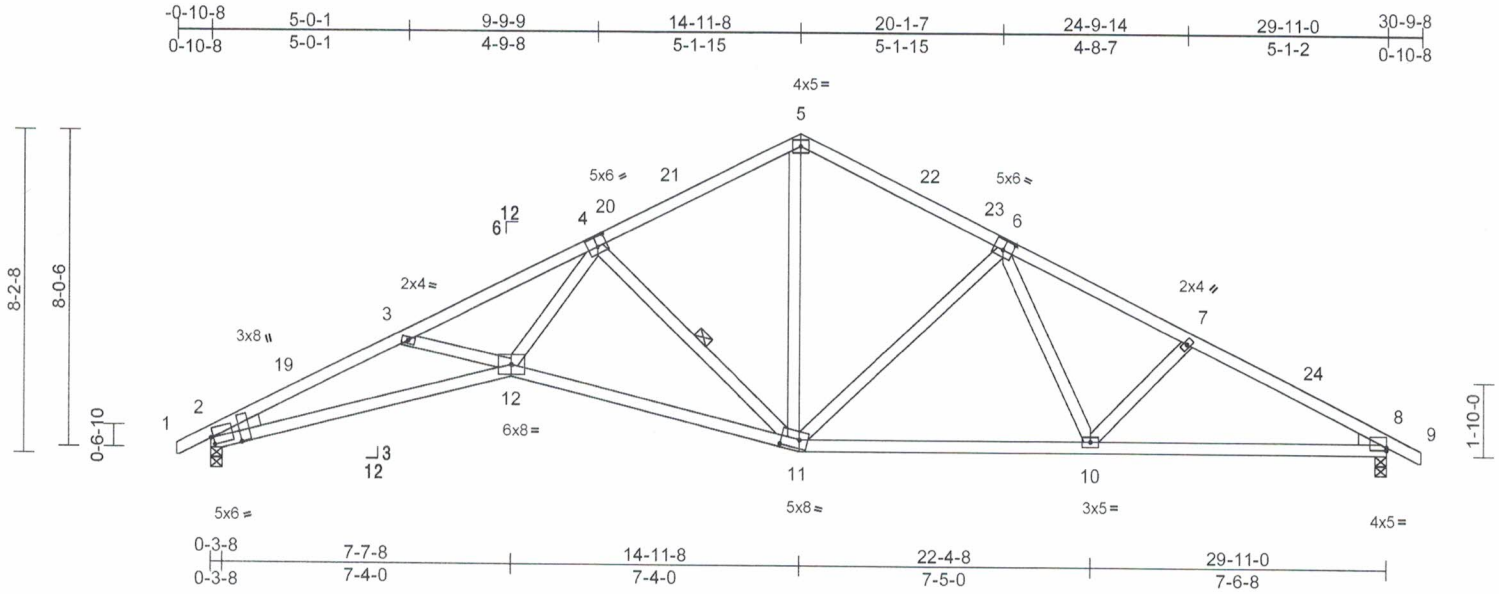

Scale = 1:58.3

Plate Offsets (X, Y): [2:0-0-12,0-2-3], [2:0-3-4,0-9-0], [4:0-3-0,0-3-0], [6:0-3-0,0-3-0], [8:Edge,0-0-14], [11:0-5-8,0-2-8]

Loading	(psf)	Spacing	2-0-0	CSI	DEFL	in	(loc)	l/defl	L/d	PLATES	GRIP	
TCLL (roof)	20.0	Plate Grip DOL	1.15	TC	0.86	Vert(LL)	-0.22	11-12	>999	240	MT20	244/190
Snow (Pf/Pg)	13.9/20.0	Lumber DOL	1.15	BC	0.79	Vert(CT)	-0.52	11-12	>693	180		
TCDL	10.0	Rep Stress Incr	YES	WB	0.70	Horz(CT)	0.22	8	n/a	n/a		
BCLL	0.0*	Code	IRC2021/TPI2014	Matrix-MSH								
BCDL	10.0											
											Weight: 156 lb	FT = 20%

**LUMBER**  
TOP CHORD 2x4 SP No.2  
BOT CHORD 2x4 SP No.2 \*Except\* 2-12:2x4 SP No.1  
WEBS 2x4 SP No.3  
WEDGE Left: 2x4 SP No.3  
Right: 2x4 SP No.3

**BRACING**  
TOP CHORD Structural wood sheathing directly applied or 2-2-0 oc purlins.  
BOT CHORD Rigid ceiling directly applied or 10-0-0 oc bracing.  
WEBS 1 Row at midpt 4-11

**REACTIONS** (size) 2=0-3-8, 8=0-3-8  
Max Horiz 2=81 (LC 14)  
Max Grav 2=1247 (LC 2), 8=1247 (LC 2)

**FORCES** (lb) - Maximum Compression/Maximum Tension  
TOP CHORD 1-2=0/28, 2-3=-3592/300, 3-5=-3404/245, 5-7=-1950/219, 7-8=-2122/205, 8-9=0/28  
BOT CHORD 2-12=-203/3218, 11-12=-96/2158, 10-11=-61/1551, 8-10=-111/1822  
WEBS 5-11=-74/927, 6-11=-552/117, 6-10=0/324, 7-10=-223/99, 3-12=-157/110, 4-12=-13/1700, 4-11=-1289/154

- TCLL: ASCE 7-16; Pr=20.0 psf (roof LL: Lum DOL=1.15 Plate DOL=1.15); Pg=20.0 psf; Pf=13.9 psf (Lum DOL=1.15 Plate DOL=1.15); Is=1.0; Rough Cat B; Fully Exp.; Ce=0.9; Cs=1.00; Ct=1.10
- Unbalanced snow loads have been considered for this design.
- This truss has been designed for greater of min roof live load of 12.0 psf or 2.00 times flat roof load of 13.9 psf on overhangs non-concurrent with other live loads.
- \* This truss has been designed for a live load of 20.0psf on the bottom chord in all areas where a rectangle 3-06-00 tall by 2-00-00 wide will fit between the bottom chord and any other members.
- Bearings are assumed to be: Joint 2 SP No.1 , Joint 8 SP No.2 .
- Bearing at joint(s) 2 considers parallel to grain value using ANSI/TPI 1 angle to grain formula. Building designer should verify capacity of bearing surface.

**LOAD CASE(S)** Standard

**NOTES**

- Unbalanced roof live loads have been considered for this design.
- Wind: ASCE 7-16; Vult=130mph (3-second gust) Vasd=103mph; TC DL=6.0psf; BC DL=6.0psf; h=25ft; Cat. II; Exp B; Enclosed; MWFRS (envelope) and C-C Exterior(2E) -0-10-1 to 2-1-15, Interior (1) 2-1-15 to 14-11-8, Exterior(2R) 14-11-8 to 17-11-8, Interior (1) 17-11-8 to 30-9-1 zone; cantilever left and right exposed ; end vertical left and right exposed;C-C for members and forces & MWFRS for reactions shown; Lumber DOL=1.60 plate grip DOL=1.33



February 7, 2025

**WARNING** - Verify design parameters and READ NOTES ON THIS AND INCLUDED MITEK REFERENCE PAGE MI-7473 rev. 1/2/2023 BEFORE USE  
Design valid for use only with MiTek® connectors. This design is based only upon parameters shown, and is for an individual building component, not a truss system. Before use, the building designer must verify the applicability of design parameters and properly incorporate this design into the overall building design. Bracing indicated is to prevent buckling of individual truss web and/or chord members only. Additional temporary and permanent bracing is always required for stability and to prevent collapse with possible personal injury and property damage. For general guidance regarding the fabrication, storage, delivery, erection and bracing of trusses and truss systems, see ANSI/TPI1 Quality Criteria and DSB-22 available from Truss Plate Institute (www.tpinst.org) and BCSI Building Component Safety Information available from the Structural Building Component Association (www.sbcacomponents.com)



818 Soundside Road  
Edenton, NC 27932

Job	Truss	Truss Type	Qty	Ply	Coats-Charleston 1270-Roof-Charleston 1270 VFR
24120078-01	A8	Hip	1	1	Job Reference (optional) I71239843

Carter Components (Sanford, NC), Sanford, NC - 27332,

Run: 8:730 S Dec 5 2024 Print: 8:730 S Dec 5 2024 MiTek Industries, Inc. Wed Feb 05 13:37:02  
ID: GuiXkLWAcEchznIH2wdtQy9ZrU-RFC?PsB70Hq3NSgPqnL8w3ulTXbGkWrCDOI7J4zJC7f

Page: 1

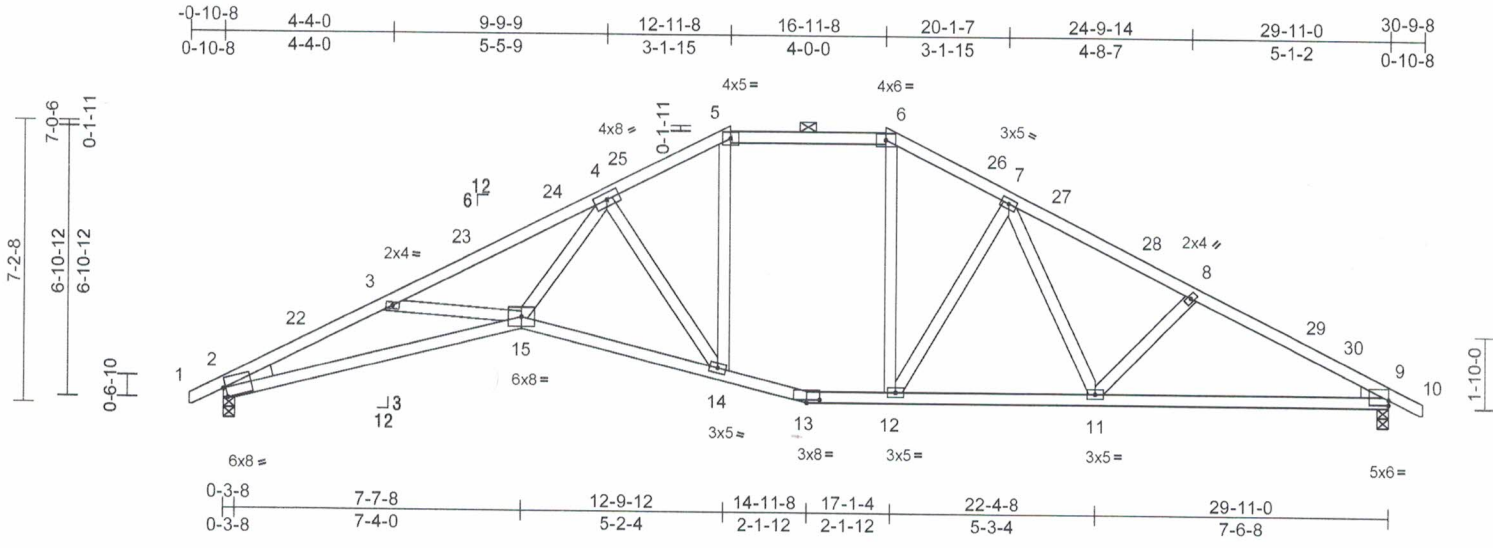

Scale = 1:58.8

Plate Offsets (X, Y): [2:0-0-12,Edge], [9:Edge,0-1-10], [13:0-4-0,0-1-0]

Loading	(psf)	Spacing	2-0-0	CSI	DEFL	in	(loc)	l/defl	L/d	PLATES	GRIP	
TCLL (roof)	20.0	Plate Grip DOL	1.15	TC	0.87	Vert(LL)	-0.44	14-15	>810	240	MT20	244/190
Snow (Pf/Pg)	18.9/20.0	Lumber DOL	1.15	BC	0.92	Vert(CT)	-0.78	14-15	>458	180		
TCDL	10.0	Rep Stress Incr	YES	WB	0.88	Horz(CT)	0.32	9	n/a	n/a		
BCLL	0.0*	Code	IRC2021/TPI2014	Matrix-MSH								
BCDL	10.0											

Weight: 159 lb FT = 20%

**LUMBER**  
TOP CHORD 2x4 SP No.1 \*Except\* 5-6:2x4 SP No.2  
BOT CHORD 2x4 SP No.1 \*Except\* 15-13:2x4 SP 2400F  
2.0E, 13-9:2x4 SP No.2  
WEBS 2x4 SP No.3  
WEDGE Left: 2x4 SP No.3  
Right: 2x4 SP No.3

**BRACING**  
TOP CHORD Structural wood sheathing directly applied or  
2-1-0 oc purlins, except  
2-0-0 oc purlins (4-1-10 max.): 5-6.  
BOT CHORD Rigid ceiling directly applied or 2-2-0 oc  
bracing.

**REACTIONS** (size) 2=0-3-8, 9=0-3-8  
Max Horiz 2=-70 (LC 13)  
Max Grav 2=1445 (LC 44), 9=1446 (LC 44)

**FORCES** (lb) - Maximum Compression/Maximum  
Tension  
TOP CHORD 1-2=0/28, 2-3=-4280/336, 3-4=-3988/265,  
4-5=-1842/237, 5-6=-1541/223,  
6-7=-1769/232, 7-8=-2257/217,  
8-9=-2518/219, 9-10=0/28  
BOT CHORD 2-15=-246/3826, 14-15=-101/2490,  
13-14=-17/1524, 12-13=-16/1541,  
11-12=-70/1796, 9-11=-134/2167  
WEBS 3-15=-199/132, 4-15=-32/2048,  
4-14=-1512/150, 7-12=-484/105, 7-11=0/355,  
8-11=-335/103, 5-14=-37/764, 6-12=-29/455

- Wind: ASCE 7-16; Vult=130mph (3-second gust)  
Vasd=103mph; TCDL=6.0psf; BCDL=6.0psf; h=25ft; Cat.  
II; Exp B; Enclosed; MWFRS (envelope) and C-C  
Exterior(2E)-0-10-1 to 2-1-15, Interior (1) 2-1-15 to  
12-11-8, Exterior(2E) 12-11-8 to 16-11-8, Exterior(2R)  
16-11-8 to 21-2-7, Interior (1) 21-2-7 to 30-9-1 zone;  
cantilever left and right exposed; end vertical left and  
right exposed; C-C for members and forces & MWFRS  
for reactions shown; Lumber DOL=1.60 plate grip  
DOL=1.33
- TCLL: ASCE 7-16; Pr=20.0 psf (roof LL: Lum DOL=1.15  
Plate DOL=1.15); Pg=20.0 psf; Pf=18.9 psf (Lum  
DOL=1.15 Plate DOL=1.15); Is=1.0; Rough Cat B; Fully  
Exp.; Ce=0.9; Cs=1.00; Ct=1.10, Lu=50-0-0
- Unbalanced snow loads have been considered for this  
design.
- This truss has been designed for greater of min roof live  
load of 12.0 psf or 2.00 times flat roof load of 13.9 psf on  
overhangs non-concurrent with other live loads.
- Provide adequate drainage to prevent water ponding.
- \* This truss has been designed for a live load of 20.0psf  
on the bottom chord in all areas where a rectangle  
3-06-00 tall by 2-00-00 wide will fit between the bottom  
chord and any other members.
- Bearings are assumed to be: Joint 2 SP No.1, Joint 9  
SP No.2.
- Bearing at joint(s) 2 considers parallel to grain value  
using ANSI/TPI 1 angle to grain formula. Building  
designer should verify capacity of bearing surface.
- Graphical purlin representation does not depict the size  
or the orientation of the purlin along the top and/or  
bottom chord.

LOAD CASE(S) Standard

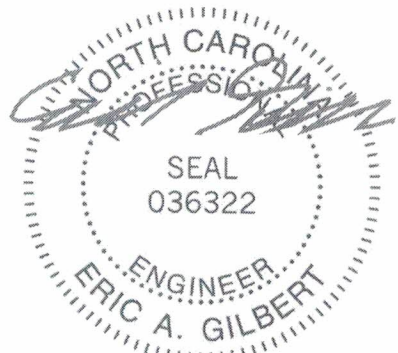

February 7, 2025

**WARNING** - Verify design parameters and READ NOTES ON THIS AND INCLUDED MITTEK REFERENCE PAGE MII-7473 rev. 1/2/2023 BEFORE USE  
Design valid for use only with MiTek® connectors. This design is based only upon parameters shown, and is for an individual building component, not  
a truss system. Before use, the building designer must verify the applicability of design parameters and properly incorporate this design into the overall  
building design. Bracing indicated is to prevent buckling of individual truss web and/or chord members only. Additional temporary and permanent bracing  
is always required for stability and to prevent collapse with possible personal injury and property damage. For general guidance regarding the  
fabrication, storage, delivery, erection and bracing of trusses and truss systems, see ANSI/TPI1 Quality Criteria and DSB-22 available from Truss Plate Institute (www.tpinst.org)  
and BCSI Building Component Safety Information available from the Structural Building Component Association (www.sbcacomponents.com)



818 Soundside Road  
Edenton, NC 27932



Job	Truss	Truss Type	Qty	Ply	Coats-Charleston 1270-Roof-Charleston 1270 VFR
24120078-01	A9	Hip	1	1	171239844
Job Reference (optional)					

Carter Components (Sanford, NC), Sanford, NC - 27332,

Run: 8.73 S Dec 5 2024 Print: 8.730 S Dec 5 2024 MiTek Industries, Inc. Wed Feb 05 13:37:03  
 ID:HnPW2ypA8DJ3FNAmXZXCWY9Zpd-RFC?Psb70Hq3NSgPqnLw3ulTXbGKWrCDoi7J4zJC?7f

Page: 1

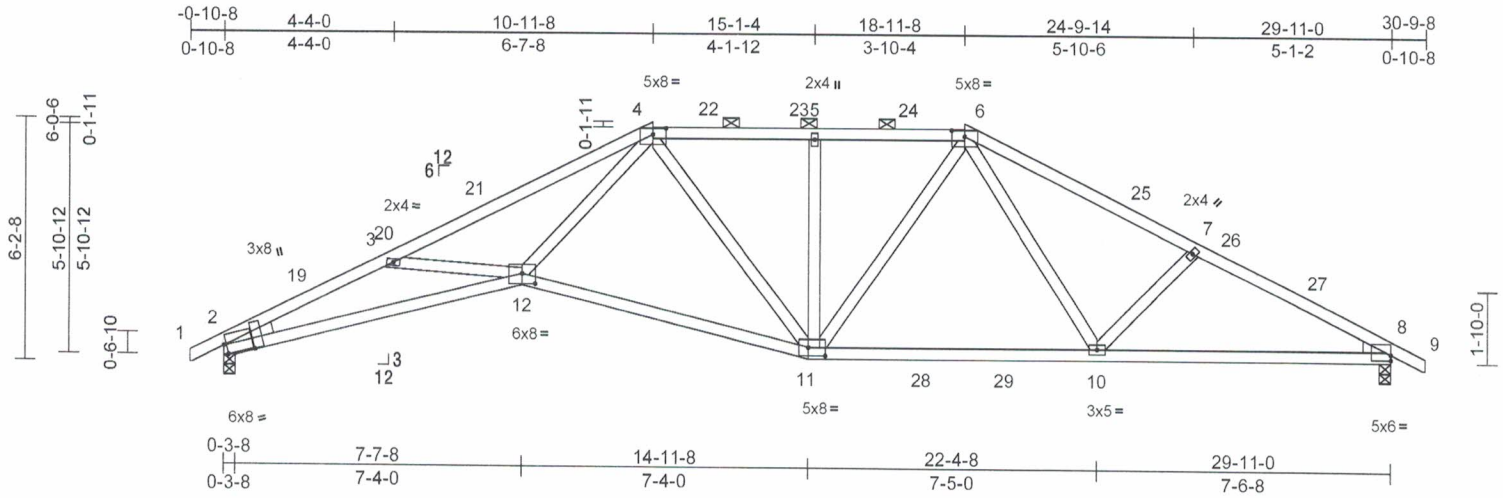

Scale = 1:58.7

Plate Offsets (X, Y): [2:0-0-12,Edge], [2:0-3-4,0-9-0], [4:0-4-0,0-1-15], [6:0-4-0,0-1-15], [8:Edge,0-1-10], [11:0-5-4,0-2-8], [12:0-4-0,0-3-4]

Loading	(psf)	Spacing	2-0-0	CSI	DEFL	in	(loc)	l/defl	L/d	PLATES	GRIP
TCLL (roof)	20.0	Plate Grip DOL	1.15	TC	0.87	-0.29	11-12	>999	240	MT20	244/190
Snow (Pf/Pg)	18.9/20.0	Lumber DOL	1.15	BC	0.95	Vert(CT)	-0.56	11-12	>647		
TCDL	10.0	Rep Stress Incr	YES	WB	0.89	Horz(CT)	0.22	8	n/a		
BCLL	0.0*	Code	IRC2021/TPI2014	Matrix-MSH							
BCDL	10.0										
Weight: 155 lb											FT = 20%

**LUMBER**  
 TOP CHORD 2x4 SP 2400F 2.0E \*Except\* 4-6:2x4 SP No.2  
 BOT CHORD 2x4 SP No.2 \*Except\* 2-12:2x4 SP No.1  
 WEBS 2x4 SP No.3  
 WEDGE Left: 2x4 SP No.3  
 Right: 2x4 SP No.3

**BRACING**  
 TOP CHORD Structural wood sheathing directly applied or 2-2=0 oc purlins, except 2-0-0 oc purlins (4-0-3 max.): 4-6.  
 BOT CHORD Rigid ceiling directly applied or 2-2-0 oc bracing.

**REACTIONS** (size) 2=0-3-8, 8=0-3-8  
 Max Horiz 2=-59 (LC 13)  
 Max Grav 2=1446 (LC 50), 8=1454 (LC 50)

**FORCES** (lb) - Maximum Compression/Maximum Tension  
 TOP CHORD 1-2=0/32, 2-3=-4611/377, 3-4=-4245/251, 4-5=-1995/226, 5-6=-2002/229, 6-7=-2466/220, 7-8=-2721/228, 8-9=0/32  
 BOT CHORD 2-12=-288/4161, 11-12=-75/2224, 10-11=-54/1766, 8-10=-146/2344  
 WEBS 3-12=-403/194, 4-12=-26/2357, 4-11=-411/47, 5-11=-402/74, 6-11=-21/398, 6-10=0/631, 7-10=-397/135

**NOTES**  
 1) Unbalanced roof live loads have been considered for this design.

- Wind: ASCE 7-16; Vult=130mph (3-second gust) Vasd=103mph; TCDL=6.0psf; BCDL=6.0psf; h=25ft; Cat. II; Exp B; Enclosed; MWFRS (envelope) and C-C Exterior(2E)-0-10-1 to 2-1-15, Interior (1) 2-1-15 to 10-11-8, Exterior(2R) 10-11-8 to 15-1-4, Interior (1) 15-1-4 to 18-11-8, Exterior(2R) 18-11-8 to 23-2-7, Interior (1) 23-2-7 to 30-9-1 zone; cantilever left and right exposed ; end vertical left and right exposed; C-C for members and forces & MWFRS for reactions shown; Lumber DOL=1.60 plate grip DOL=1.33
- TCLL: ASCE 7-16; Pr=20.0 psf (roof LL: Lum DOL=1.15 Plate DOL=1.15); Pg=20.0 psf; Pf=18.9 psf (Lum DOL=1.15 Plate DOL=1.15); Is=1.0; Rough Cat B; Fully Exp.; Ce=0.9; Cs=1.00; Ct=1.10, Lu=50-0-0
- Unbalanced snow loads have been considered for this design.
- This truss has been designed for greater of min roof live load of 12.0 psf or 2.00 times flat roof load of 13.9 psf on overhangs non-concurrent with other live loads.
- Provide adequate drainage to prevent water ponding.
- \* This truss has been designed for a live load of 20.0psf on the bottom chord in all areas where a rectangle 3-06-00 tall by 2-00-00 wide will fit between the bottom chord and any other members, with BCDL = 10.0psf.
- Bearings are assumed to be: Joint 2 SP No.1 , Joint 8 SP No.2 .
- Bearing at joint(s) 2 considers parallel to grain value using ANSI/TPI 1 angle to grain formula. Building designer should verify capacity of bearing surface.
- Graphical purlin representation does not depict the size or the orientation of the purlin along the top and/or bottom chord.

**LOAD CASE(S)** Standard

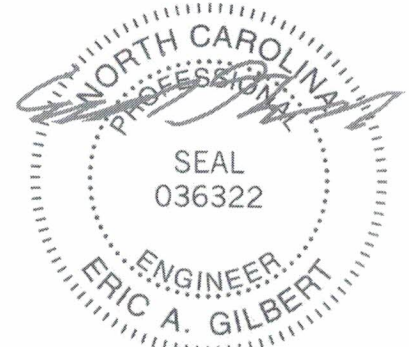

February 7, 2025

**WARNING** - Verify design parameters and READ NOTES ON THIS AND INCLUDED MITEK REFERENCE PAGE MII-7473 rev. 1/2/2023 BEFORE USE  
 Design valid for use only with MiTek® connectors. This design is based only upon parameters shown, and is for an individual building component, not a truss system. Before use, the building designer must verify the applicability of design parameters and properly incorporate this design into the overall building design. Bracing indicated is to prevent buckling of individual truss web and/or chord members only. Additional temporary and permanent bracing is always required for stability and to prevent collapse with possible personal injury and property damage. For general guidance regarding the fabrication, storage, delivery, erection and bracing of trusses and truss systems, see ANSI/TPI Quality Criteria and DSB-22 available from Truss Plate Institute (www.tpinst.org) and BCSI Building Component Safety Information available from the Structural Building Component Association (www.sbcacomponents.com)



818 Soundside Road  
 Edenton, NC 27932

Job 24120078-01	Truss A10	Truss Type Hip	Qty 1	Ply 1	Coats-Charleston 1270-Roof-Charleston 1270 VFR 171239845
Carter Components (Sanford, NC), Sanford, NC - 27332,					Job Reference (optional)

Carter Components (Sanford, NC), Sanford, NC - 27332,

Run: 8.73 S Dec 5 2024 Print: 8.730 S Dec 5 2024 MITek Industries, Inc. Wed Feb 05 13:37:03  
ID:eZnhSBex\_MHnnsfx2lZgTjy9Zol-RfC?PsB70Hq3NSgPqnLw3ulTxbGKwRCDol7J4zJC?f

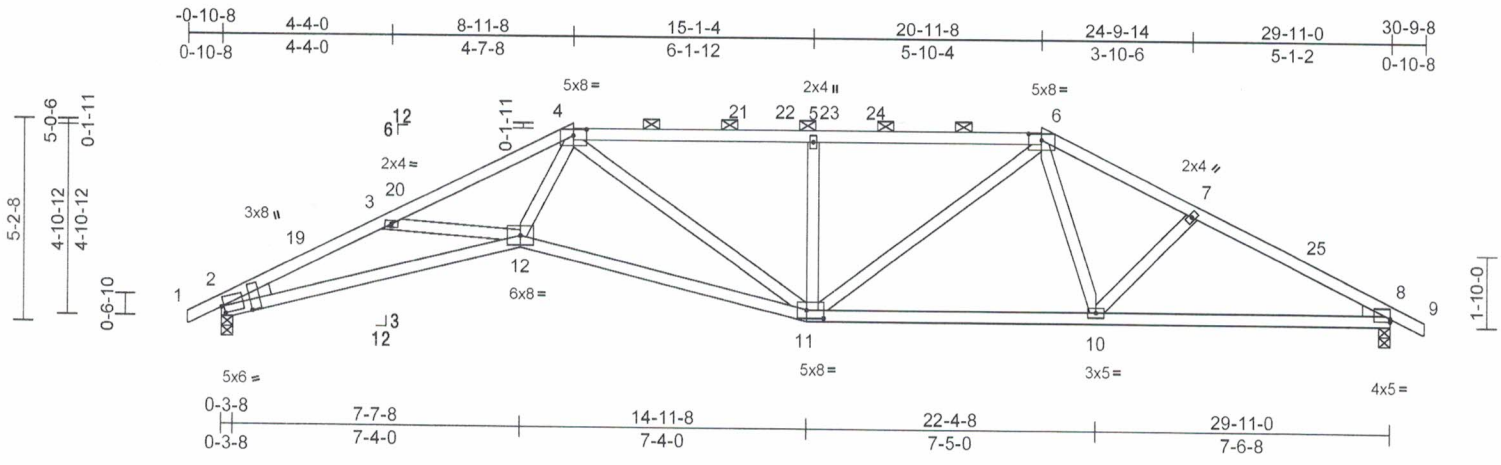

Scale = 1:58.6

Plate Offsets (X, Y): [2:0-0-12,0-2-3], [2:0-3-4,0-9-0], [4:0-4-0,0-1-15], [6:0-4-0,0-1-15], [8:Edge,0-0-14], [11:0-5-4,0-2-8]

Loading	(psf)	Spacing	2-0-0	CSI	DEFL	in	(loc)	l/defl	L/d	PLATES	GRIP
TCLL (roof)	20.0	Plate Grip DOL	1.15	TC	Vert(LL)	-0.21	11-12	>999	240	MT20	244/190
Snow (Pf/Pg)	18.9/20.0	Lumber DOL	1.15	BC	Vert(CT)	-0.49	11-12	>729	180		
TCDL	10.0	Rep Stress Incr	YES	WB	Horz(CT)	0.21	8	n/a	n/a		
BCLL	0.0*	Code	IRC2021/TPI2014	Matrix-MSH							
BCDL	10.0										
										Weight: 149 lb	FT = 20%

**LUMBER**  
TOP CHORD 2x4 SP No.1 \*Except\* 4-6:2x4 SP No.2  
BOT CHORD 2x4 SP No.2 \*Except\* 2-12:2x4 SP No.1  
WEBS 2x4 SP No.3  
WEDGE Left: 2x4 SP No.3  
Right: 2x4 SP No.3

**BRACING**  
TOP CHORD Structural wood sheathing directly applied or 2-3-11 oc purlins, except 2-0-0 oc purlins (2-11-12 max.): 4-6.  
BOT CHORD Rigid ceiling directly applied or 10-0-0 oc bracing.

**REACTIONS** (size) 2=0-3-8, 8=0-3-8  
Max Horiz 2=-49 (LC 13)  
Max Grav 2=1296 (LC 44), 8=1296 (LC 44)

**FORCES** (lb) - Maximum Compression/Maximum Tension  
TOP CHORD 1-2=0/32, 2-3=-3564/340, 3-4=-3480/254, 4-5=-2130/242, 5-6=-2148/246, 6-7=-1959/206, 7-8=-2119/216, 8-9=0/32  
BOT CHORD 2-12=-250/3186, 11-12=-116/2492, 10-11=-66/1633, 8-10=-132/1817  
WEBS 3-12=-217/265, 4-12=-14/1631, 4-11=-587/14, 5-11=-619/127, 6-11=-45/641, 6-10=0/372, 7-10=-296/106

- Wind: ASCE 7-16; Vult=130mph (3-second gust) Vasd=103mph; TC DL=6.0psf; BCDL=6.0psf; h=25ft; Cat. II; Exp B; Enclosed; MWFRS (envelope) and C-C Exterior(2E) -0-10-1 to 2-1-15, Interior (1) 2-1-15 to 8-11-8, Exterior(2R) 8-11-8 to 13-2-7, Interior (1) 13-2-7 to 20-11-8, Exterior(2R) 20-11-8 to 24-11-3, Interior (1) 24-11-3 to 30-9-1 zone; cantilever left and right exposed; end vertical left and right exposed; C-C for members and forces & MWFRS for reactions shown; Lumber DOL=1.60 plate grip DOL=1.33
- TCLL: ASCE 7-16; Pr=20.0 psf (roof LL: Lum DOL=1.15 Plate DOL=1.15); Pg=20.0 psf; Pf=18.9 psf (Lum DOL=1.15 Plate DOL=1.15); Is=1.0; Rough Cat B; Fully Exp.; Ce=0.9; Cs=1.00; Ct=1.10, Lu=50-0-0
- Unbalanced snow loads have been considered for this design.
- This truss has been designed for greater of min roof live load of 12.0 psf or 2.00 times flat roof load of 13.9 psf on overhangs non-concurrent with other live loads.
- Provide adequate drainage to prevent water ponding.
- \* This truss has been designed for a live load of 20.0psf on the bottom chord in all areas where a rectangle 3-06-00 tall by 2-00-00 wide will fit between the bottom chord and any other members.
- Bearings are assumed to be: Joint 2 SP No.1, Joint 8 SP No.2.
- Bearing at joint(s) 2 considers parallel to grain value using ANSI/TPI 1 angle to grain formula. Building designer should verify capacity of bearing surface.
- Graphical purlin representation does not depict the size or the orientation of the purlin along the top and/or bottom chord.

LOAD CASE(S) Standard

**NOTES**  
1) Unbalanced roof live loads have been considered for this design.



February 7, 2025

**WARNING** - Verify design parameters and READ NOTES ON THIS AND INCLUDED MITEK REFERENCE PAGE MII-7473 rev. 1/2/2023 BEFORE USE  
Design valid for use only with MITek® connectors. This design is based only upon parameters shown, and is for an individual building component, not a truss system. Before use, the building designer must verify the applicability of design parameters and properly incorporate this design into the overall building design. Bracing indicated is to prevent buckling of individual truss web and/or chord members only. Additional temporary and permanent bracing is always required for stability and to prevent collapse with possible personal injury and property damage. For general guidance regarding the fabrication, storage, delivery, erection and bracing of trusses and truss systems, see ANSI/TPI1 Quality Criteria and DSB-22 available from Truss Plate Institute (www.tpinst.org) and BCSI Building Component Safety Information available from the Structural Building Component Association (www.sbcacomponents.com)



818 Soundside Road  
Edenton, NC 27932

Job 24120078-01	Truss HJ10	Truss Type Diagonal Hip Girder	Qty 4	Ply 1	Coats-Charleston 1270-Roof-Charleston 1270 VFR Job Reference (optional) I71239846
--------------------	---------------	-----------------------------------	----------	----------	---

Carter Components (Sanford, NC), Sanford, NC - 27332,

Run: 8.73 S Dec 5 2024 Print: 8.730 S Dec 5 2024 MITek Industries, Inc. Wed Feb 05 13:37:03  
ID:9sHlonQ9oke9K1xLU3sMABy9Zwm-RfC?PsB70Hq3NSgPqnL8w3ulTXbGKwRCDoI7J4zJC?F

Page: 1

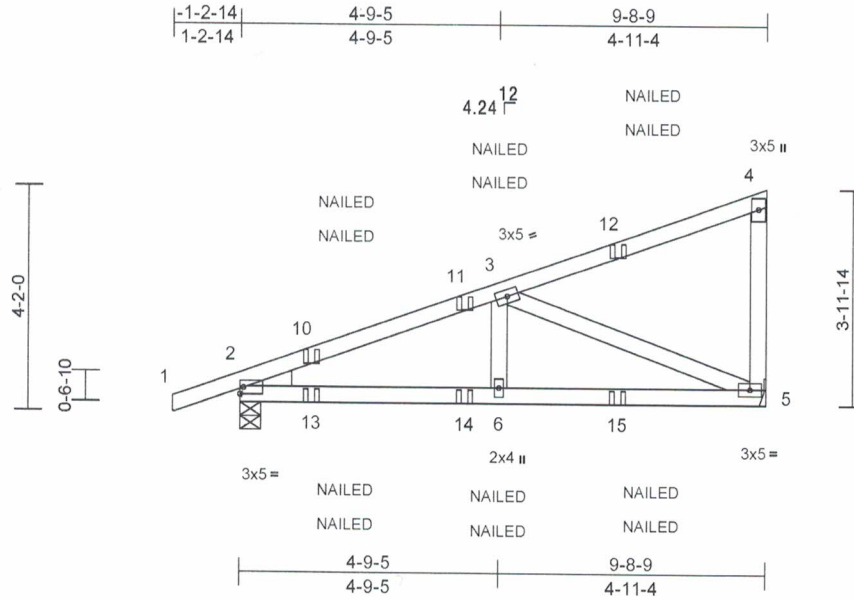

Scale = 1:42.3

Loading	(psf)	Spacing	2-0-0	CSI	TC	0.76	DEFL	in	(loc)	l/defl	L/d	PLATES	GRIP
TCLL (roof)	20.0	Plate Grip DOL	1.15	TC	0.76	Vert(LL)	-0.03	5-6	>999	240	MT20	244/190	
Snow (Pf/Pg)	13.9/20.0	Lumber DOL	1.15	BC	0.49	Vert(CT)	-0.06	5-6	>999	180			
TCDL	10.0	Rep Stress Incr	NO	WB	0.39	Horz(CT)	0.01	5	n/a	n/a			
BCLL	0.0*	Code	IRC2021/TPI2014	Matrix-MSH									
BCDL	10.0												

Weight: 48 lb FT = 20%

**LUMBER**  
TOP CHORD 2x4 SP No.2  
BOT CHORD 2x4 SP No.2  
WEBS 2x4 SP No.3  
WEDGE Left: 2x4 SP No.3

**BRACING**  
TOP CHORD Structural wood sheathing directly applied or 6-0-0 oc purlins, except end verticals.  
BOT CHORD Rigid ceiling directly applied or 10-0-0 oc bracing.

**REACTIONS** (size) 2=0-4-9, 5= Mechanical  
Max Horiz 2=114 (LC 10)  
Max Uplift 2=-41 (LC 7), 5=-33 (LC 8)  
Max Grav 2=498 (LC 2), 5=566 (LC 18)

**FORCES** (lb) - Maximum Compression/Maximum Tension  
TOP CHORD 1-2=0/30, 2-3=-809/23, 3-4=-133/34, 4-5=-200/47  
BOT CHORD 2-6=-101/732, 5-6=-66/732  
WEBS 3-6=0/143, 3-5=-752/58

- 5) \* This truss has been designed for a live load of 20.0psf on the bottom chord in all areas where a rectangle 3-06-00 tall by 2-00-00 wide will fit between the bottom chord and any other members.
- 6) Bearings are assumed to be: Joint 2 SP No.2 .
- 7) Refer to girder(s) for truss to truss connections.
- 8) Provide mechanical connection (by others) of truss to bearing plate capable of withstanding 41 lb uplift at joint 2 and 33 lb uplift at joint 5.
- 9) "NAILED" indicates 3-10d (0.148"x3") or 2-12d (0.148"x3.25") toe-nails per NDS guidelines.
- 10) In the LOAD CASE(S) section, loads applied to the face of the truss are noted as front (F) or back (B).
- LOAD CASE(S)** Standard
- 1) Dead + Snow (balanced): Lumber Increase=1.15, Plate Increase=1.15  
Uniform Loads (lb/ft)  
Vert: 1-4=-48, 5-7=-20  
Concentrated Loads (lb)  
Vert: 11=-41 (F=-21, B=-21), 12=-191 (F=-95, B=-95), 13=2 (F=1, B=1), 14=-14 (F=-7, B=-7), 15=-75 (F=-38, B=-38)

- NOTES**
- 1) Wind: ASCE 7-16; Vult=130mph (3-second gust)  
Vasd=103mph; TC DL=6.0psf; BCDL=6.0psf; h=25ft; Cat. II; Exp B; Enclosed; MWFRS (envelope); cantilever left and right exposed ; end vertical left and right exposed; Lumber DOL=1.60 plate grip DOL=1.33
  - 2) TCLL: ASCE 7-16; Pr=20.0 psf (roof LL: Lum DOL=1.15 Plate DOL=1.15); Pg=20.0 psf; Pf=13.9 psf (Lum DOL=1.15 Plate DOL=1.15); Is=1.0; Rough Cat B; Fully Exp.; Ce=0.9; Cs=1.00; Ct=1.10
  - 3) Unbalanced snow loads have been considered for this design.
  - 4) This truss has been designed for greater of min roof live load of 12.0 psf or 2.00 times flat roof load of 13.9 psf on overhangs non-concurrent with other live loads.

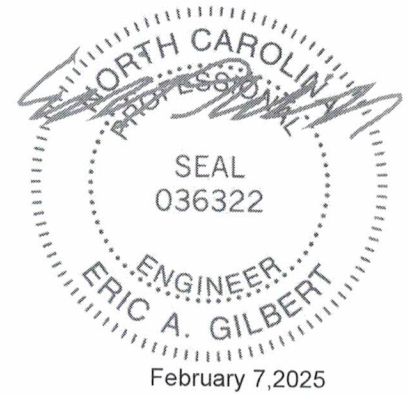

**WARNING** - Verify design parameters and READ NOTES ON THIS AND INCLUDED MITEK REFERENCE PAGE MII-7473 rev. 1/2/2023 BEFORE USE  
Design valid for use only with MITek® connectors. This design is based only upon parameters shown, and is for an individual building component, not a truss system. Before use, the building designer must verify the applicability of design parameters and properly incorporate this design into the overall building design. Bracing indicated is to prevent buckling of individual truss web and/or chord members only. Additional temporary and permanent bracing is always required for stability and to prevent collapse with possible personal injury and property damage. For general guidance regarding the fabrication, storage, delivery, erection and bracing of trusses and truss systems, see ANSI/TPI1 Quality Criteria and DSB-22 available from Truss Plate Institute (www.tpinst.org) and BCSI Building Component Safety Information available from the Structural Building Component Association (www.sbcacomponents.com)

ENGINEERING BY  
**TRENCO**  
A MITek Affiliate

818 Soundside Road  
Edenton, NC 27932

Job 24120078-01	Truss J1	Truss Type Jack-Open	Qty 8	Ply 1	Coats-Charleston 1270-Roof-Charleston 1270 VFR 171239847 Job Reference (optional)
--------------------	-------------	-------------------------	----------	----------	---

Carter Components (Sanford, NC), Sanford, NC - 27332,

Run: 8.73 S Dec 5 2024 Print: 8.730 S Dec 5 2024 MiTek Industries, Inc. Wed Feb 05 13:37:03  
ID: \_I7bU0IFOMGjwKcDLF9nEpy9Zwx-RfC?PsB70Hq3NSgPqnl8w3uITXbGKWrCDoi7J4zC7f

Page: 1

-0-10-8 | 0-10-7  
0-10-8 | 0-10-7

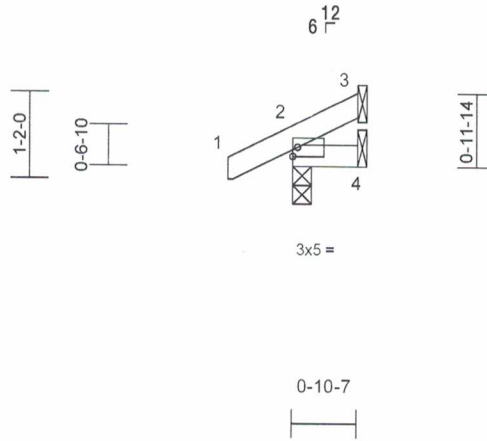

Scale = 1:30.8

Loading	(psf)	Spacing		CSI		DEFL	in	(loc)	l/defl	L/d	PLATES	GRIP
TCLL (roof)	20.0	Plate Grip DOL	2-0-0	TC	0.06	Vert(LL)	0.00	7	>999	240	MT20	244/190
Snow (Pf/Pg)	13.9/20.0	Lumber DOL	1.15	BC	0.02	Vert(CT)	0.00	7	>999	180		
TCDL	10.0	Rep Stress Incr	YES	WB	0.00	Horz(CT)	0.00	3	n/a	n/a		
BCLL	0.0*	Code	IRC2021/TPI2014	Matrix-MP								
BCDL	10.0										Weight: 4 lb	FT = 20%

**LUMBER**

TOP CHORD 2x4 SP No.2  
BOT CHORD 2x4 SP No.2

**BRACING**

TOP CHORD Structural wood sheathing directly applied or 0-10-7 oc purlins.  
BOT CHORD Rigid ceiling directly applied or 10-0-0 oc bracing.

**REACTIONS**

(size) 2=0-3-0, 3= Mechanical, 4= Mechanical  
Max Horiz 2=19 (LC 15)  
Max Uplift 2=-5 (LC 15), 3=-8 (LC 21), 4=-6 (LC 21)  
Max Grav 2=117 (LC 22), 3=11 (LC 22), 4=6 (LC 19)

**FORCES**

(lb) - Maximum Compression/Maximum Tension

TOP CHORD 1-2=0/28, 2-3=-44/48  
BOT CHORD 2-4=-28/7

**NOTES**

- 1) Wind: ASCE 7-16; Vult=130mph (3-second gust) Vasd=103mph; TCDL=6.0psf; BCDL=6.0psf; h=25ft; Cat. II; Exp B; Enclosed; MWFRS (envelope) and C-C Exterior(2E) zone; cantilever left and right exposed; end vertical left and right exposed; C-C for members and forces & MWFRS for reactions shown; Lumber DOL=1.60 plate grip DOL=1.33
- 2) TCLL: ASCE 7-16; Pr=20.0 psf (roof LL: Lum DOL=1.15 Plate DOL=1.15); Pg=20.0 psf; Pf=13.9 psf (Lum DOL=1.15 Plate DOL=1.15); Is=1.0; Rough Cat B; Fully Exp.; Ce=0.9; Cs=1.00; Ct=1.10
- 3) Unbalanced snow loads have been considered for this design.
- 4) This truss has been designed for greater of min roof live load of 12.0 psf or 2.00 times flat roof load of 13.9 psf on overhangs non-concurrent with other live loads.

- 5) \* This truss has been designed for a live load of 20.0psf on the bottom chord in all areas where a rectangle 3-06-00 tall by 2-00-00 wide will fit between the bottom chord and any other members.
- 6) Bearings are assumed to be: , Joint 2 SP No.2 .
- 7) Refer to girder(s) for truss to truss connections.
- 8) Provide mechanical connection (by others) of truss to bearing plate at joint(s) 2.
- 9) Provide mechanical connection (by others) of truss to bearing plate capable of withstanding 5 lb uplift at joint 2, 6 lb uplift at joint 4 and 8 lb uplift at joint 3.

LOAD CASE(S) Standard

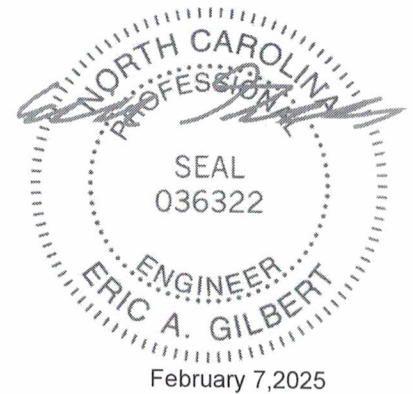

February 7, 2025

**WARNING** - Verify design parameters and READ NOTES ON THIS AND INCLUDED MITTEK REFERENCE PAGE MII-7473 rev. 1/2/2023 BEFORE USE  
Design valid for use only with MiTek® connectors. This design is based only upon parameters shown, and is for an individual building component, not a truss system. Before use, the building designer must verify the applicability of design parameters and properly incorporate this design into the overall building design. Bracing indicated is to prevent buckling of individual truss web and/or chord members only. Additional temporary and permanent bracing is always required for stability and to prevent collapse with possible personal injury and property damage. For general guidance regarding the fabrication, storage, delivery, erection and bracing of trusses and truss systems, see **ANSI/TPH Quality Criteria and DSB-22** available from Truss Plate Institute (www.tpinst.org) and **BCSI Building Component Safety Information** available from the Structural Building Component Association (www.sbcacomponents.com)

ENGINEERING BY  
**TRENCO**  
A MiTek Affiliate

818 Soundside Road  
Edenton, NC 27932

Job 24120078-01	Truss J3	Truss Type Jack-Open	Qty 8	Ply 1	Coats-Charleston 1270-Roof-Charleston 1270 VFR Job Reference (optional) I71239848
--------------------	-------------	-------------------------	----------	----------	---

Carter Components (Sanford, NC), Sanford, NC - 27332,

Run: 8.73 S Dec 5 2024 Print: 8.730 S Dec 5 2024 MiTek Industries, Inc. Wed Feb 05 13:37:03  
ID:2M?r3KG?sk0?g1SrEq7J9Oy9Zwz-RfC?PsB70Hq3NSgPqnL8w3ulTXbGKWrCDol7J4zJC?r

Page: 1

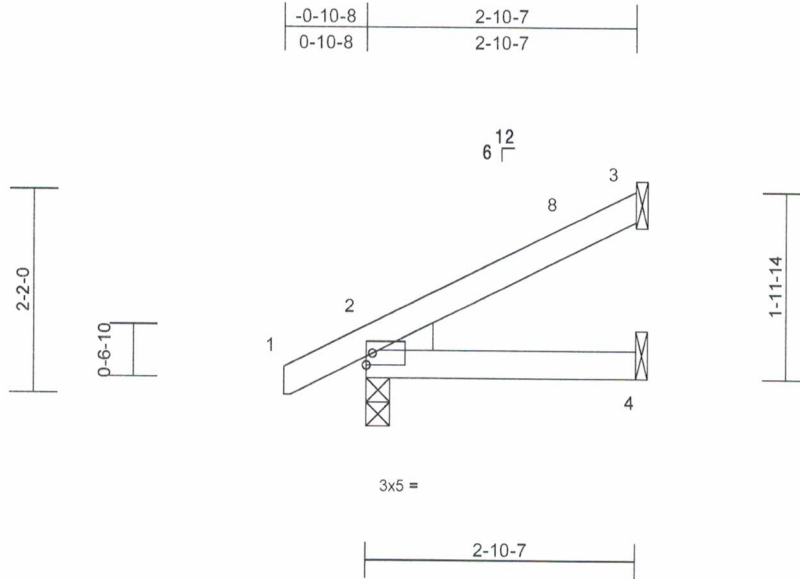

Scale = 1:24.4

Loading	(psf)	Spacing	2-0-0	CSI	TC	0.12	DEFL	in	(loc)	l/defl	L/d	PLATES	GRIP
TCLL (roof)	20.0	Plate Grip DOL	1.15	BC	0.08	Vert(LL)	0.00	4-7	>999	240	MT20	244/190	
Snow (Pf/Pg)	13.9/20.0	Lumber DOL	1.15	WB	0.00	Vert(CT)	-0.01	4-7	>999	180			
TCDL	10.0	Rep Stress Incr	YES	Matrix-MP		Horz(CT)	0.00	3	n/a	n/a			
BCLL	0.0*	Code	IRC2021/TPI2014										
BCDL	10.0												

Weight: 12 lb FT = 20%

**LUMBER**

TOP CHORD 2x4 SP No.2  
BOT CHORD 2x4 SP No.2  
WEDGE Left: 2x4 SP No.3

**BRACING**

TOP CHORD Structural wood sheathing directly applied or 2-10-7 oc purlins.  
BOT CHORD Rigid ceiling directly applied or 10-0-0 oc bracing.

**REACTIONS** (size) 2=0-3-0, 3= Mechanical, 4= Mechanical  
Max Horiz 2=44 (LC 15)  
Max Uplift 3=-23 (LC 15)  
Max Grav 2=199 (LC 22), 3=86 (LC 22), 4=34 (LC 22)

**FORCES**

(lb) - Maximum Compression/Maximum Tension  
TOP CHORD 1-2=0/28, 2-3=-96/66  
BOT CHORD 2-4=-123/53

**NOTES**

- 1) Wind: ASCE 7-16; Vult=130mph (3-second gust)  
Vasd=103mph; TCDL=6.0psf; BCDL=6.0psf; h=25ft; Cat. II; Exp B; Enclosed; MWFRS (envelope) and C-C Exterior(2E) -0-10-1 to 2-1-15, Interior (1) 2-1-15 to 2-9-11 zone; cantilever left and right exposed; end vertical left and right exposed; C-C for members and forces & MWFRS for reactions shown; Lumber DOL=1.60 plate grip DOL=1.33
- 2) TCLL: ASCE 7-16; Pr=20.0 psf (roof LL: Lum DOL=1.15 Plate DOL=1.15); Pg=20.0 psf; Pf=13.9 psf (Lum DOL=1.15 Plate DOL=1.15); Is=1.0; Rough Cat B; Fully Exp.; Ce=0.9; Cs=1.00; Ct=1.10
- 3) Unbalanced snow loads have been considered for this design.
- 4) This truss has been designed for greater of min roof live load of 12.0 psf or 2.00 times flat roof load of 13.9 psf on overhangs non-concurrent with other live loads.

- 5) \* This truss has been designed for a live load of 20.0psf on the bottom chord in all areas where a rectangle 3-06-00 tall by 2-00-00 wide will fit between the bottom chord and any other members.
- 6) Bearings are assumed to be: , Joint 2 SP No.2 .
- 7) Refer to girder(s) for truss to truss connections.
- 8) Provide mechanical connection (by others) of truss to bearing plate capable of withstanding 23 lb uplift at joint 3.

**LOAD CASE(S)** Standard

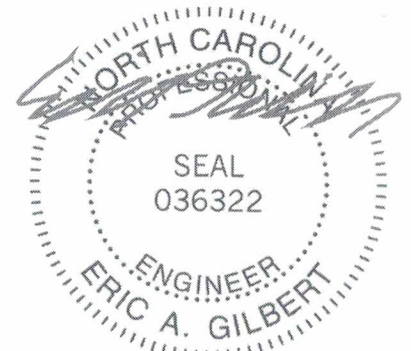

February 7, 2025

**WARNING** - Verify design parameters and READ NOTES ON THIS AND INCLUDED MITEK REFERENCE PAGE MII-7473 rev. 1/2/2023 BEFORE USE  
Design valid for use only with MiTek® connectors. This design is based only upon parameters shown, and is for an individual building component, not a truss system. Before use, the building designer must verify the applicability of design parameters and properly incorporate this design into the overall building design. Bracing indicated is to prevent buckling of individual truss web and/or chord members only. Additional temporary and permanent bracing is always required for stability and to prevent collapse with possible personal injury and property damage. For general guidance regarding the fabrication, storage, delivery, erection and bracing of trusses and truss systems, see ANSI/TPI Quality Criteria and DSB-22 available from Truss Plate Institute (www.tpinet.org) and BCSI Building Component Safety Information available from the Structural Building Component Association (www.sbcacomponents.com)

ENGINEERING BY  
**TRENCO**  
A MiTek Affiliate

818 Soundside Road  
Edenton, NC 27932

Job 24120078-01	Truss J5	Truss Type Jack-Open	Qty 8	Ply 1	Coats-Charleston 1270-Roof-Charleston 1270 VFR 171239849
--------------------	-------------	-------------------------	----------	----------	---

Carter Components (Sanford, NC), Sanford, NC - 27332,

Run: 8.73 S Dec 5 2024 Print: 8.730 S Dec 5 2024 MITek Industries, Inc. Wed Feb 05 13:37:03  
ID:dnKIRJE7ZpdRpZjGYiacXmy9Zx0-RfC?PsB70Hq3NSgPqnL8w3uITXbGKWrcDol7J4zJC7f

Page: 1

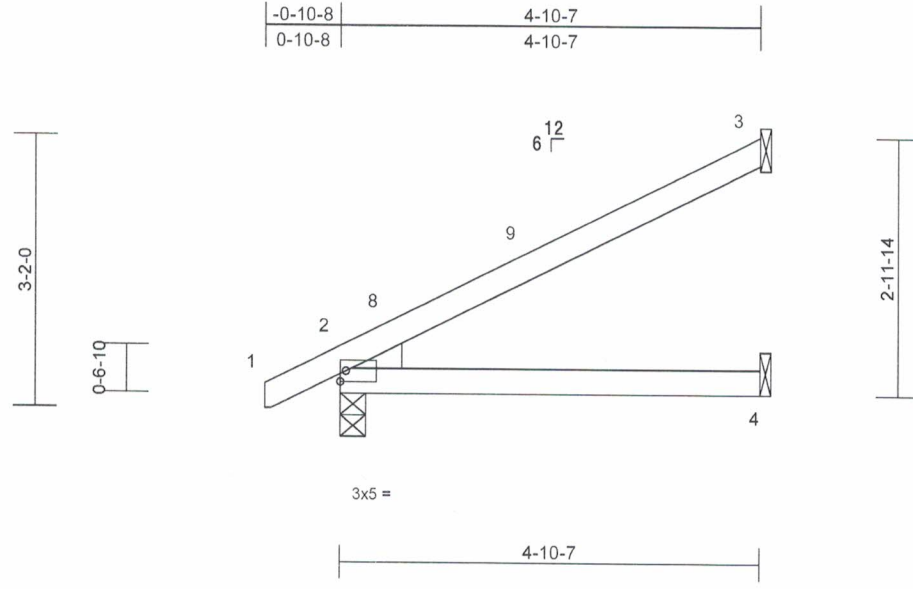

Scale = 1:26.6

Loading	(psf)	Spacing	2-0-0	CSI	TC	0.45	DEFL	in	(loc)	l/defl	L/d	PLATES	GRIP
TCLL (roof)	20.0	Plate Grip DOL	1.15	BC	0.29	Vert(LL)	0.03	4-7	>999	240	MT20	244/190	
Snow (Pf/Pg)	13.9/20.0	Lumber DOL	1.15	WB	0.00	Vert(CT)	-0.06	4-7	>951	180			
TCDL	10.0	Rep Stress Incr	YES	Matrix-MP		Horz(CT)	0.01	2	n/a	n/a			
BCLL	0.0*	Code	IRC2021/TPI2014										
BCDL	10.0												

Weight: 18 lb FT = 20%

**LUMBER**  
 TOP CHORD 2x4 SP No.2  
 BOT CHORD 2x4 SP No.2  
 WEDGE Left: 2x4 SP No.3

**BRACING**  
 TOP CHORD Structural wood sheathing directly applied or 4-10-7 oc purlins.  
 BOT CHORD Rigid ceiling directly applied or 10-0-0 oc bracing.

**REACTIONS** (size) 2=0-3-8, 3= Mechanical, 4= Mechanical  
 Max Horiz 2=70 (LC 15)  
 Max Uplift 3=-39 (LC 15)  
 Max Grav 2=272 (LC 22), 3=163 (LC 22), 4=66 (LC 22)

**FORCES** (lb) - Maximum Compression/Maximum Tension  
 TOP CHORD 1-2=0/28, 2-3=-192/130  
 BOT CHORD 2-4=-293/159

5) \* This truss has been designed for a live load of 20.0psf on the bottom chord in all areas where a rectangle 3-06-00 tall by 2-00-00 wide will fit between the bottom chord and any other members.  
 6) Bearings are assumed to be: , Joint 2 SP No.2 .  
 7) Refer to girder(s) for truss to truss connections.  
 8) Provide mechanical connection (by others) of truss to bearing plate capable of withstanding 39 lb uplift at joint 3.

**LOAD CASE(S)** Standard

**NOTES**

- 1) Wind: ASCE 7-16; Vult=130mph (3-second gust) Vasd=103mph; TCDL=6.0psf; BCDL=6.0psf; h=25ft; Cat. II; Exp B; Enclosed; MWFRS (envelope) and C-C Exterior(2E) -0-10-1 to 2-1-15, Interior (1) 2-1-15 to 4-9-11 zone; cantilever left and right exposed ; end vertical left and right exposed;C-C for members and forces & MWFRS for reactions shown; Lumber DOL=1.60 plate grip DOL=1.33
- 2) TCLL: ASCE 7-16; Pr=20.0 psf (roof LL: Lum DOL=1.15 Plate DOL=1.15); Pg=20.0 psf; Pf=13.9 psf (Lum DOL=1.15 Plate DOL=1.15); Is=1.0; Rough Cat B; Fully Exp.; Ce=0.9; Cs=1.00; Ct=1.10
- 3) Unbalanced snow loads have been considered for this design.
- 4) This truss has been designed for greater of min roof live load of 12.0 psf or 2.00 times flat roof load of 13.9 psf on overhangs non-concurrent with other live loads.

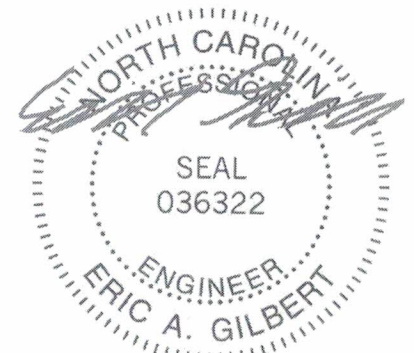

February 7, 2025

Job 24120078-01	Truss J7	Truss Type Jack-Open	Qty 15	Ply 1	Coats-Charleston 1270-Roof-Charleston 1270 VFR 171239850
--------------------	-------------	-------------------------	-----------	----------	---

Carter Components (Sanford, NC), Sanford, NC - 27332,

Run: 8.73 S Dec 5 2024 Print: 8.730 S Dec 5 2024 MiTek Industries, Inc. Wed Feb 05 13:37:03  
ID:wPmnTwxAvBf1hFZlyk?FVqy9Zwe-RfC?PsB70Hq3NSgPqnLw3ulTXbGKwRCDoi7J4zJC7f

Page: 1

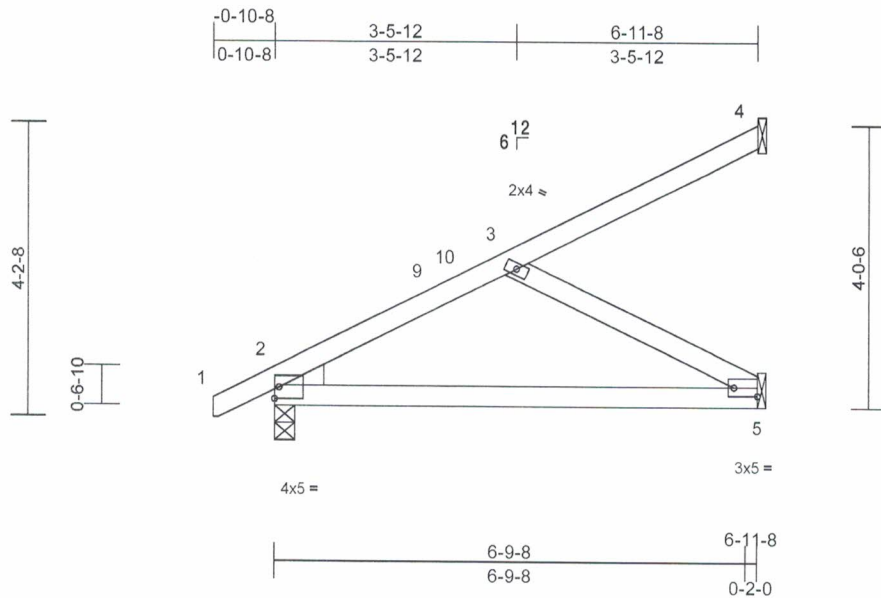

Scale = 1:33

Plate Offsets (X, Y): [5:Edge,0-1-8]

Loading	(psf)	Spacing	2-0-0	CSI	DEFL	in	(loc)	l/defl	L/d	PLATES	GRIP	
TCLL (roof)	20.0	Plate Grip DOL	1.15	TC	0.21	Vert(LL)	0.01	5-8	>999	240	MT20	244/190
Snow (Pf/Pg)	13.9/20.0	Lumber DOL	1.15	BC	0.32	Vert(CT)	-0.08	5-8	>999	180		
TCDL	10.0	Rep Stress Incr	YES	WB	0.12	Horz(CT)	0.00	2	n/a	n/a		
BCLL	0.0*	Code	IRC2021/TPI2014	Matrix-MP								
BCDL	10.0											

Weight: 30 lb FT = 20%

**LUMBER**

TOP CHORD 2x4 SP No.2  
BOT CHORD 2x4 SP No.2  
WEBS 2x4 SP No.3  
WEDGE Left: 2x4 SP No.3

**BRACING**

TOP CHORD Structural wood sheathing directly applied or 6-0-0 oc purlins.  
BOT CHORD Rigid ceiling directly applied or 10-0-0 oc bracing.

**REACTIONS** (size) 2=0-3-8, 4= Mechanical, 5= Mechanical  
Max Horiz 2=97 (LC 15)  
Max Uplift 4=-32 (LC 15)  
Max Grav 2=331 (LC 2), 4=110 (LC 22), 5=210 (LC 22)

**FORCES**

(lb) - Maximum Compression/Maximum Tension  
TOP CHORD 1-2=0/28, 2-3=-345/70, 3-4=-74/37  
BOT CHORD 2-5=-256/309  
WEBS 3-5=-349/225

**NOTES**

- 1) Wind: ASCE 7-16; Vult=130mph (3-second gust) Vasd=103mph; TCDL=6.0psf; BCDL=6.0psf; h=25ft; Cat. II; Exp B; Enclosed; MWFRS (envelope) and C-C Exterior(2E) -0-10-1 to 2-1-15, Interior (1) 2-1-15 to 6-10-12 zone; cantilever left and right exposed ; end vertical left and right exposed;C-C for members and forces & MWFRS for reactions shown; Lumber DOL=1.60 plate grip DOL=1.33
- 2) TCLL: ASCE 7-16; Pr=20.0 psf (roof LL: Lum DOL=1.15 Plate DOL=1.15); Pg=20.0 psf; Pf=13.9 psf (Lum DOL=1.15 Plate DOL=1.15); Is=1.0; Rough Cat B; Fully Exp.; Ce=0.9; Cs=1.00; Ct=1.10
- 3) Unbalanced snow loads have been considered for this design.

- 4) This truss has been designed for greater of min roof live load of 12.0 psf or 2.00 times flat roof load of 13.9 psf on overhangs non-concurrent with other live loads.
- 5) \* This truss has been designed for a live load of 20.0psf on the bottom chord in all areas where a rectangle 3-06-00 tall by 2-00-00 wide will fit between the bottom chord and any other members.
- 6) Bearings are assumed to be: , Joint 2 SP No.2 .
- 7) Refer to girder(s) for truss to truss connections.
- 8) Provide mechanical connection (by others) of truss to bearing plate capable of withstanding 32 lb uplift at joint 4.

**LOAD CASE(S)** Standard



February 7, 2025

**WARNING** - Verify design parameters and READ NOTES ON THIS AND INCLUDED MITEK REFERENCE PAGE MII-7473 rev. 1/2/2023 BEFORE USE  
Design valid for use only with MiTek® connectors. This design is based only upon parameters and properly incorporate this design into the overall building design. Before use, the building designer must verify the applicability of design parameters shown, and is for an individual building component, not a truss system. Bracing indicated is to prevent buckling of individual truss web and/or chord members only. Additional temporary and permanent bracing is always required for stability and to prevent collapse with possible personal injury and property damage. For general guidance regarding the fabrication, storage, delivery, erection and bracing of trusses and truss systems, see ANSI/TPI1 Quality Criteria and DSB-22 available from Truss Plate Institute (www.tpinst.org) and BCSI Building Component Safety Information available from the Structural Building Component Association (www.sbcacomponents.com)



818 Soundside Road  
Edenton, NC 27932

Job 24120078-01	Truss J7A	Truss Type Jack-Open	Qty 3	Ply 1	Coats-Charleston 1270-Roof-Charleston 1270 VFR 171239851
--------------------	--------------	-------------------------	----------	----------	---

Carter Components (Sanford, NC), Sanford, NC - 27332,

Run: 8.73 S Dec 5 2024 Print: 8.730 S Dec 5 2024 MiTek Industries, Inc. Wed Feb 05 13:37:04  
ID: M8gKe2CMAvAJtchbbR?re8y9ZuT-RC?Psb70Hq3NSgPqnL8w3uITxhGKwRCDoi7J4zJC?F

Page: 1

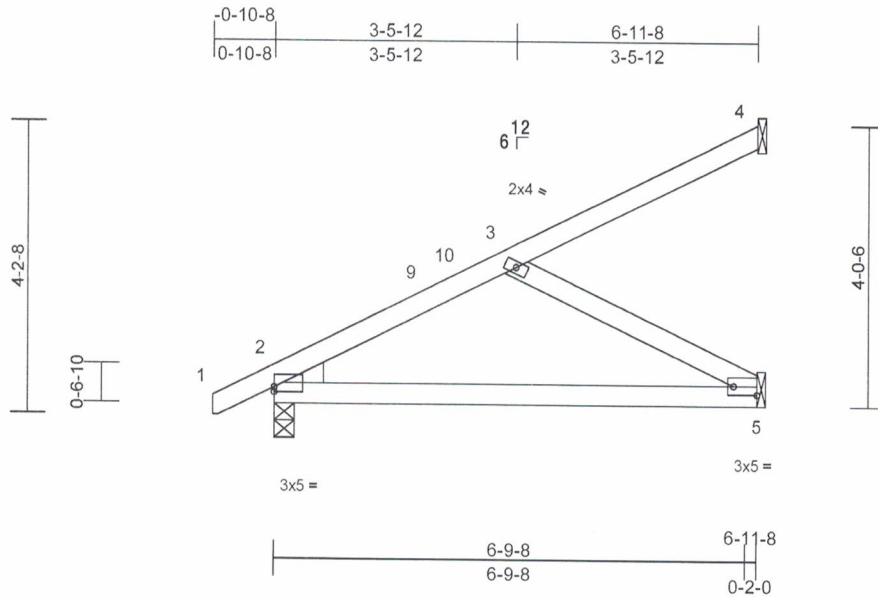

Scale = 1:33

Plate Offsets (X, Y): [2:Edge,0-0-14], [5:Edge,0-1-8]

Loading	(psf)	Spacing	2-0-0	CSI	TC	0.40	DEFL	in	(loc)	l/defl	L/d	PLATES	GRIP
TCLL (roof)	20.0	Plate Grip DOL	1.15	BC	0.38	Vert(LL)	0.01	5-8	>999	240	MT20	244/190	
Snow (Pf/Pg)	13.9/20.0	Lumber DOL	1.15	WB	0.19	Vert(CT)	-0.07	5-8	>999	180			
TCDL	10.0	Rep Stress Incr	NO	Matrix-MP		Horz(CT)	0.01	5	n/a	n/a			
BCLL	0.0*	Code	IRC2021/TPI2014										
BCDL	10.0												

Weight: 30 lb FT = 20%

**LUMBER**

TOP CHORD 2x4 SP No.2  
BOT CHORD 2x4 SP No.2  
WEBS 2x4 SP No.3  
WEDGE Left: 2x4 SP No.3

**BRACING**

TOP CHORD Structural wood sheathing directly applied or 6-0-0 oc purlins.  
BOT CHORD Rigid ceiling directly applied or 10-0-0 oc bracing.

**REACTIONS**

(size) 2=0-3-8, 4= Mechanical, 5= Mechanical  
Max Horiz 2=97 (LC 15)  
Max Grav 2=416 (LC 2), 4=190 (LC 22), 5=290 (LC 22)

**FORCES**

(lb) - Maximum Compression/Maximum Tension  
TOP CHORD 1-2=0/28, 2-3=-524/0, 3-4=-121/64  
BOT CHORD 2-5=-230/455  
WEBS 3-5=-513/97

**NOTES**

- 1) Wind: ASCE 7-16; Vult=130mph (3-second gust)  
Vasd=103mph; TCDL=6.0psf; BCDL=6.0psf; h=25ft; Cat. II; Exp B; Enclosed; MWFRS (envelope) and C-C Exterior(2E) -0-10-1 to 2-1-15, Interior (1) 2-1-15 to 6-10-12 zone; cantilever left and right exposed ; end vertical left and right exposed; C-C for members and forces & MWFRS for reactions shown; Lumber DOL=1.60 plate grip DOL=1.33
- 2) TCLL: ASCE 7-16; Pr=20.0 psf (roof LL: Lum DOL=1.15 Plate DOL=1.15); Pg=20.0 psf; Pf=13.9 psf (Lum DOL=1.15 Plate DOL=1.15); Is=1.0; Rough Cat B; Fully Exp.; Ce=0.9; Cs=1.00; Ct=1.10
- 3) Unbalanced snow loads have been considered for this design.

- 4) This truss has been designed for greater of min roof live load of 12.0 psf or 2.00 times flat roof load of 13.9 psf on overhangs non-concurrent with other live loads.
- 5) \* This truss has been designed for a live load of 20.0psf on the bottom chord in all areas where a rectangle 3-06-00 tall by 2-00-00 wide will fit between the bottom chord and any other members.
- 6) Bearings are assumed to be: , Joint 2 SP No.2 .
- 7) Refer to girder(s) for truss to truss connections.
- 8) Load case(s) 1, 2 has/have been modified. Building designer must review loads to verify that they are correct for the intended use of this truss.

**LOAD CASE(S)** Standard

- 1) Dead + Snow (balanced): Lumber Increase=1.15, Plate Increase=1.15  
Uniform Loads (lb/ft)  
Vert: 1-9=-48, 4-9=-99, 5-6=-20
- 2) Dead + Roof Live (balanced): Lumber Increase=1.15, Plate Increase=1.15  
Uniform Loads (lb/ft)  
Vert: 1-9=-60, 4-9=-112, 5-6=-20

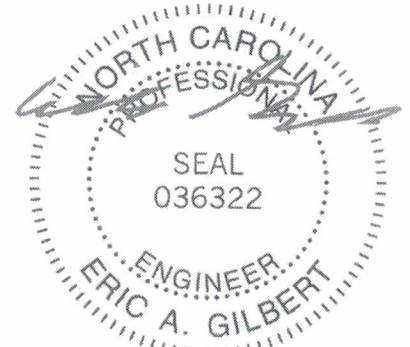

February 7, 2025

**WARNING** - Verify design parameters and READ NOTES ON THIS AND INCLUDED MITTEK REFERENCE PAGE MII-7473 rev. 1/2/2023 BEFORE USE

Design valid for use only with MiTek® connectors. This design is based only upon parameters shown, and is for an individual building component, not a truss system. Before use, the building designer must verify the applicability of design parameters and properly incorporate this design into the overall building design. Bracing indicated is to prevent buckling of individual truss web and/or chord members only. Additional temporary and permanent bracing is always required for stability and to prevent collapse with possible personal injury and property damage. For general guidance regarding the fabrication, storage, delivery, erection and bracing of trusses and truss systems, see ANSI/TPI Quality Criteria and DSB-22 available from Truss Plate Institute (www.tpinet.org) and BCSI Building Component Safety Information available from the Structural Building Component Association (www.sbcacompnents.com)



818 Soundside Road  
Edenton, NC 27932



# Symbols

## PLATE LOCATION AND ORIENTATION

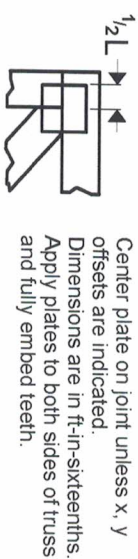

Center plate on joint unless x, y offsets are indicated. Dimensions are in ft-in-sixteenths. Apply plates to both sides of truss and fully embed teeth.

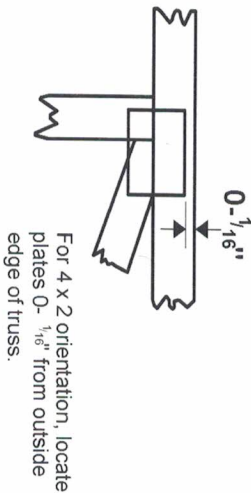

For 4 x 2 orientation, locate plates 0- $\frac{1}{16}$ " from outside edge of truss.



This symbol indicates the required direction of slots in connector plates.

\* Plate location details available in MITek software or upon request.

## PLATE SIZE

4 X 4

The first dimension is the plate width measured perpendicular to slots. Second dimension is the length parallel to slots.

## LATERAL BRACING LOCATION



Indicated by symbol shown and/or by text in the bracing section of the output. Use T or I bracing if indicated.

## BEARING

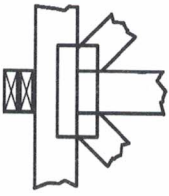

Indicates location where bearings (supports) occur. Icons vary but reaction section indicates joint number/letter where bearings occur. Min size shown is for crushing only.

## Industry Standards:

ANSI/TP1: National Design Specification for Metal Plate Connected Wood Truss Construction.  
DSB-22: Design Standard for Bracing.  
BCSI: Building Component Safety Information, Guide to Good Practice for Handling, Installing, Restraining & Bracing of Metal Plate Connected Wood Trusses.

# Numbering System



1 Joint ID  
2 TOP CHORDS  
3 Joints

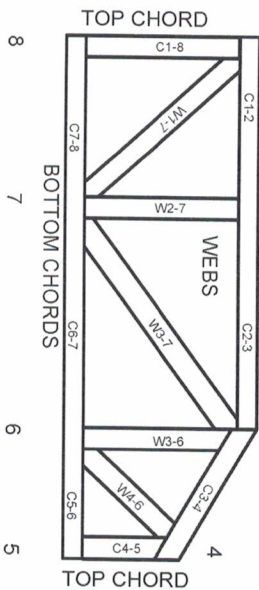

JOINTS ARE GENERALLY NUMBERED/LETTERED CLOCKWISE AROUND THE TRUSS STARTING AT THE JOINT FARTHEST TO THE LEFT.

CHORDS AND WEBS ARE IDENTIFIED BY END JOINT NUMBERS/LETTERS.

## Product Code Approvals

ICC-ES Reports:

ESR-1988, ESR-2362, ESR-2685, ESR-3282  
ESR-4722, ESL-1388

## Design General Notes

Trusses are designed for wind loads in the plane of the truss unless otherwise shown.

Lumber design values are in accordance with ANSI/TP1 section 6.3 These truss designs rely on Lumber values established by others.

© 2023 MITek® All Rights Reserved

**MITek**

ENGINEERING BY  
**TRENCO**  
A MITek Affiliate

MITek Engineering Reference Sheet: MIL-7473 rev. 1/2/2023

# General Safety Notes

## Failure to Follow Could Cause Property Damage or Personal Injury

1. Additional stability bracing for truss system, e.g. diagonal or X-bracing, is always required. See BCSI.
2. Truss bracing must be designed by an engineer. For wide truss spacing, individual lateral braces themselves may require bracing, or alternative Tor I bracing should be considered.
3. Never exceed the design loading shown and never stack materials on inadequately braced trusses.
4. Provide copies of this truss design to the building designer, erection supervisor, property owner and all other interested parties.
5. Cut members to bear tightly against each other.
6. Place plates on each face of truss at each joint and embed fully. Knots and wane at joint locations are regulated by ANSI/TP1.
7. Design assumes trusses will be suitably protected from the environment in accord with ANSI/TP1.
8. Unless otherwise noted, moisture content of lumber shall not exceed 19% at time of fabrication.
9. Unless expressly noted, this design is not applicable for use with fire retardant, preservative treated, or green lumber.
10. Camber is a non-structural consideration and is the responsibility of truss fabricator. General practice is to camber for dead load deflection.
11. Plate type, size, orientation and location dimensions indicated are minimum plating requirements.
12. Lumber used shall be of the species and size, and in all respects, equal to or better than that specified.
13. Top chords must be sheathed or purlins provided at spacing indicated on design.
14. Bottom chords require lateral bracing at 10 ft. spacing, or less, if no ceiling is installed, unless otherwise noted.
15. Connections not shown are the responsibility of others.
16. Do not cut or alter truss member or plate without prior approval of an engineer.
17. Install and load vertically unless indicated otherwise.
18. Use of green or treated lumber may pose unacceptable environmental, health or performance risks. Consult with project engineer before use.
19. Review all portions of this design (front, back, words and pictures) before use. Reviewing pictures alone is not sufficient.
20. Design assumes manufacture in accordance with ANSI/TP1 Quality Criteria.
21. The design does not take into account any dynamic or other loads other than those expressly stated.