

Wellers Knoll Lot 88

WILLOW

ELEVATION - C



**FRONT DOOR
STYLE PER
PURCHASE
ORDER**

GENERAL NOTES:

SITE CONSTRUCTION:

- 1) SOIL BEARING CALCULATIONS BASED ON 2000 PSF MIN. REFER TO THE FOUNDATION/FOOTING SCHEDULE.
- 2) BACK FILL SHALL BE FREE FROM VEGETATION AND CONSTRUCTION DEBRIS.
- 3) BACK FILL SHALL BE PLACED IN LIFTS AND COMPACTED IN SUCH A MANNER AS TO NOT DAMAGE THE FOUNDATION WALLS OR ANY WATERPROOFING/ DAMP PROOFING MATERIALS.

FRAMING:

- 1) ALL DIMENSIONS ARE FROM FACE OF STUD TO FACE OF STUD. ALL STUDS ARE 3 1/2" UNLESS NOTED. ALL DIMENSIONS PRESENTED HERE ARE FRAME DIMENSIONS ONLY.
- 2) PROVIDE 1x BLOCKING UNDER ALL EXTERIOR SLIDING DOORS.
- 3) JOIST HANGERS, WHERE REQUIRED, SHALL BE USED WITHOUT ANGLES.
- 4) INSTALL FIRE STOPPING AND/ OR DRAFT STOPPING AS REQUIRED.
- 5) PROVIDE CUTTING, NOTCHING, NAILING REQUIREMENTS PER 2009-IRC SECTIONS R502.8 R602, R802.7.

THERMAL & MOISTURE PROTECTION:

- 1) INSTALL FIRE STOPPING AND/ OR DRAFT STOPPING AS REQUIRED.
- 2) ATTIC VENTILATION SHALL BE PROVIDED AT 1/150th OF THE AREA OF THE SPACE VENTILATED. CROSS VENTILATION WITH HALF OF THE VENTILATED AREA SHALL BE PROVIDED BY RIDGE OR GABLE VENTS AND THE OTHER HALF BY EAVE OR CORNICE VENTS. VENTS SHALL BE PLACED SO AS TO NOT ALLOW INFILTRATION OF RAIN OR SNOW.
- 3) PROVIDE APPROVED TILE BACKER BOARD FOR ALL SHOWER AND BATH SPACE.
- 4) PROVIDE ICE-SHIELD PER CODE.
- 5) ROOF VENTING TO BE PROVIDED AS SHOWN. SOFFIT, RIDGE, AND OTHER ROOF VENTS TO BE INSTALLED AS NOTED ON THE DRAWINGS & AS PER MANUFACTURERS RECOMMENDATIONS.

DOORS & WINDOW:

- 1) WINDOW CALL OUT PER PLAN. VERIFY WINDOW MANUFACTURER WITH PROJECT MANAGER.
- 2) REVIEW ALL WINDOW HEADER HEIGHTS PER PLATE HT. AND VERIFY W/ ELEVATIONS AND CORNICE DETAILS.
- 3) TEMPERED GLASS SHALL BE USED IN ALL HAZARDOUS AREAS.
- 4) FRONT DOOR WIDTH AS REQUIRED BY CODE.
- 5) GARAGE DOOR AS REQUIRED BY CODE.
- 6) EMERGENCY - SLEEPING ROOMS SHALL HAVE AT LEAST ONE EGRESS OPENING OF NOT LESS THAN 5.7 SF AND A CLEAR OPENING OF NOT LESS THAN 20" WIDE X 24" HIGH AND SHALL NOT BE MORE THAN 44" ABOVE THE FLOOR.

INSULATION:

EXTERIOR WALLS ZONE 3:
R-13 BATTS MINIMUM. VERIFY

CEILING WITH ATTIC ABOVE COMPRESSED INSULATION:
R-38 BATTS MINIMUM. VERIFY

CEILING WITH ATTIC ABOVE UNCOMPRESSED INSULATION (HEELS IN TRUSSES):
R-30 BATTS MINIMUM. VERIFY

FLOOR OVER GARAGE:
R-19 BATTS MINIMUM. VERIFY

ATTIC KNEEWALL:
R-19 BATTS MINIMUM. VERIFY

BUILDING CODE ANALYSIS

APPLICABLE CODES 2018 NCRC/ 2018 IBC
USER GROUP: SINGLE FAMILY
CONSTRUCTION CLASS: UNPROTECTED
HEIGHT LIMITATION: N/A
EMERGENCY ESCAPE: EGRESS OR RESCUE WINDOWS FROM SLEEPING ROOM SHALL HAVE A MINIMUM OF 5.7 SQ. FT.
GARAGE / HOUSE CEILING/ HOUSE ASSEMBLY: 1/2" GYPSUM BD. WALL & 5/8" TYPE "X" GYPSUM BD. CEILING W/ 20 MINUTE GARAGE/HOUSE DOOR

DESIGN LOAD:
LIVE LOAD:
 SLEEPING = 30 PSF
 NON-SLEEPING = 40 PSF
 DECKS = 40 PSF
 DEAD LOAD = 10 PSF
 BASIC WIND SPEED = 115 MPH
 EXPOSURE B (CHARLOTTE)
 STAIR LOAD = 40 PSF
 ROOF LIVE LOAD = 20 PSF
 LATERAL SOIL PRESSURE = 30 PCF (ASSUMED)

NOTE: VERIFY ALL APPLICABLE BUILDING CODES WITH STATE AND LOCAL JURISDICTION PRIOR TO CONSTRUCTION

- 1) THE ATTACHED PLANS & SPECIFICATIONS ARE THE SOLE PROPERTY OF DAVIDSON HOMES. ANY UNAUTHORIZED USE OF THESE PLANS WITHOUT PRIOR WRITTEN CONSENT OF DAVIDSON HOMES IS STRICTLY PROHIBITED.
- 2) MAIN STREET DESIGNS OF GEORGIA, LLC DESIGNS HOUSING AS SET FORTH BY THE FORMAT AND PROVISIONS OF THE INTERNATIONAL RESIDENTIAL CODE (IRC), AND THE NATIONAL ELECTRIC CODE (NEC).
- 3) THESE PLANS ARE SUBJECT TO MODIFICATIONS TO MEET CODE REQUIREMENTS AND/OR TO FACILITATE MECHANICAL/ ELECTRICAL/ PLUMBING INSTALLATION AND/ OR TO IMPLEMENT DESIGN IMPROVEMENTS.
- 4) CONTRACTOR SHALL BE RESPONSIBLE FOR VERIFYING ALL DIMENSIONS AFFECTING CONTRACTOR'S PRODUCTS, INSTALLATIONS, OR FABRICATIONS IN THE FIELD PRIOR TO EXPEDITING THE CONSTRUCTION OF SUCH WORK. FIELD VERIFY ALL DIMENSIONS - DO NOT SCALE DRAWINGS. CONTRACTOR IS RESPONSIBLE FOR SURVEYING THE PROJECT AND BECOMING FAMILIAR WITH THE EXISTING CONDITIONS AND SCOPE OF WORK INCLUDING BUT NOT LIMITED TO SITE AND SOIL BEARING CONDITIONS.
- 5) ERRORS AND OMISSIONS WHICH MAY OCCUR IN THE CONTRACT DOCUMENTS SHALL BE BROUGHT TO THE ATTENTION OF MAIN STREET DESIGNS OF GEORGIA, LLC IN WRITING, AND WRITTEN INSTRUCTION SHALL BE OBTAINED PRIOR TO PROCEEDING WITH CONSTRUCTION. THE CONTRACTOR SHALL BE HELD RESPONSIBLE FOR ANY ERRORS, DISCREPANCIES, OR OMISSIONS FOR WHICH THE CONTRACTOR FAILED TO NOTIFY MAIN STREET DESIGNS OF GEORGIA, LLC PRIOR TO CONSTRUCTION AND/ OR FABRICATION OF THE WORK.
- 6) FLAME SPREAD AND SMOKE DENSITY NOTES:

WALLS AND CEILING:

WALL AND CEILING FINISHES SHALL HAVE A FLAME - SPREAD CLASSIFICATION OF NOT GREATER THAN 200. WALL AND CEILING FINISHES SHALL HAVE A SMOKE-DEVELOPED INDEX OF NOT GREATER THAN 450.

INSULATION:

IF BATT OR BLANKET INSULATION, INCLUDING FACINGS SUCH AS VAPOR RETARDERS OR OTHER VAPOR PERMEABLE MEMBRANES ARE LEFT EXPOSED (IN AREAS LIKE UNFINISHED BASEMENTS), THE MATERIAL SHALL HAVE A FLAME SPREAD RATING OF 25 OR LESS AND A SMOKE DEVELOPMENT RATING OF 450 OR LESS. FLAME-SPREAD AND SMOKE-DEVELOPMENT LIMITATIONS DO NOT APPLY TO FACINGS THAT IS INSTALLED IN SUBSTANTIAL CONTACT WITH THE UNEXPOSED SURFACE OF THE CEILING, FLOOR, OR WALL FINISH.

EXCEPT WHERE OTHERWISE NOTED IN SECTION R314.2, ALL FOAM PLASTIC OR FOAM PLASTIC CORES IN MANUFACTURED ASSEMBLIES USED IN BUILDING CONSTRUCTION SHALL HAVE A FLAME-SPREAD RATING OF NOT MORE THAN 75 AND SHALL HAVE A SMOKE-DEVELOPMENT RATING OF NOT MORE THAN 450 WHEN TESTED IN THE MAXIMUM THICKNESS INTENDED FOR USE IN ACCORDANCE WITH ASTM E 84.

R314.1.2 THERMAL BARRIER. FOAM PLASTIC, EXCEPT WHERE OTHERWISE NOTED, SHALL BE SEPARATED FROM THE INTERIOR OF A BUILDING BY MINIMUM 1/2-INCH (12.7 MM) GYPSUM BOARD OR AN APPROVED FINISH MATERIAL EQUIVALENT TO A THERMAL BARRIER TO LIMIT THE AVERAGE TEMPERATURE RISE OF THE UNEXPOSED SURFACE TO NO MORE THAN 250°F (121°C) AFTER 15MINUTES OF FIRE EXPOSURE TO THE ASTM E 119 STANDARD TIME TEMPERATURE CURVE. THE GYPSUM BOARD SHALL BE INSTALLED USING A MECHANICAL FASTENING SYSTEM IN ACCORDANCE WITH SECTION 702.3.5. RELIANCE ON ADHESIVES TO ENSURE THAT THE GYPSUM BOARD WILL REMAIN IN PLACE WHEN EXPOSED TO FIRE SHALL BE PROHIBITED.

CRAWL VENTING	
1053 SQ FT OF FOUNDATION TO BE VENTED	
150 SQ FT / 1 SQ FT = 7.02 SQ FT VENTILATION	
VENTS 128 SQ IN = (0.8889 SQ FT)	
CRAWL VENT	
7.020 SQ FT = 25.3 VENTS REQUIRED	
0.2778 SQ FT	
ACTUAL CRAWL VENTS PROVIDED 26	
NOTE: WHERE AN APPROVED VAPER BARRIER IS INSTALLED OVER GROUND SURFACE THE REQUIRED VENTILATION MAY BE REDUCED BY 50%	

INCLUDED OPTIONS:

1st FLOOR
DECK (standard)
FAMILY ROOM EXT W/ ALT. GUEST SUITE
OPEN RAIL

2nd FLOOR
OWNERS SPA SHOWER
2ND SINK @ BATH 2
LAUNDRY SINK

BASE HOUSE SQUARE FOOTAGE CALCULATIONS					TOTAL UNDER ROOF
ELEVATIONS	1st FLOOR	2nd FLOOR	TOTAL FIN.	FRONT PORCH	GARAGE
ELEV. C	1,053 s.f.	1,287 s.f.	2,340 s.f.	60 s.f.	466 s.f.
2,866 s.f.					
OPTIONS SQUARE FOOTAGE CALCULATIONS					
OPTIONS:					1st FLOOR
EXTENDED FAMILY W/ ALTERNATE GUEST SUITE					+130 s.f.

REVISION NUMBER	UPDATED SHOWER OPTIONS
7/1/2020	
10/23/2020	ADDED GAR SVR DR & OPT EXT FAMILY
11/6/2020	ADD OPT PORCHS TO OPT EXT FAMILY
3/30/2021	REVISION TO WH & GARAGE DOORS
02/24/2022	FIX WINDOW SIZE TO 2626 FX ON D
12/12/2024	CHANGED GUEST BED WIC DOOR SWING

MAIN STREET
 Designs of Georgia, LLC
 www.MainStreetDesignsLLC.com
 3050 Royal Blvd, South, Suite 135
 Alpharetta, GA 30022
 O. (404) 966-9722

DAVIDSON
HOMES
 Your Community Builder

RELEASE DATE	1/8" = 1'-0"
08-21-2019	
PROJECT NUMBER	
OPTION NO.	

MODEL	WILLOW
DRAWING TITLE	COVER SHEET
OPTION DESCRIPTION	

SHEET NO.
CS-1.0

Wellers Knoll Lot 88

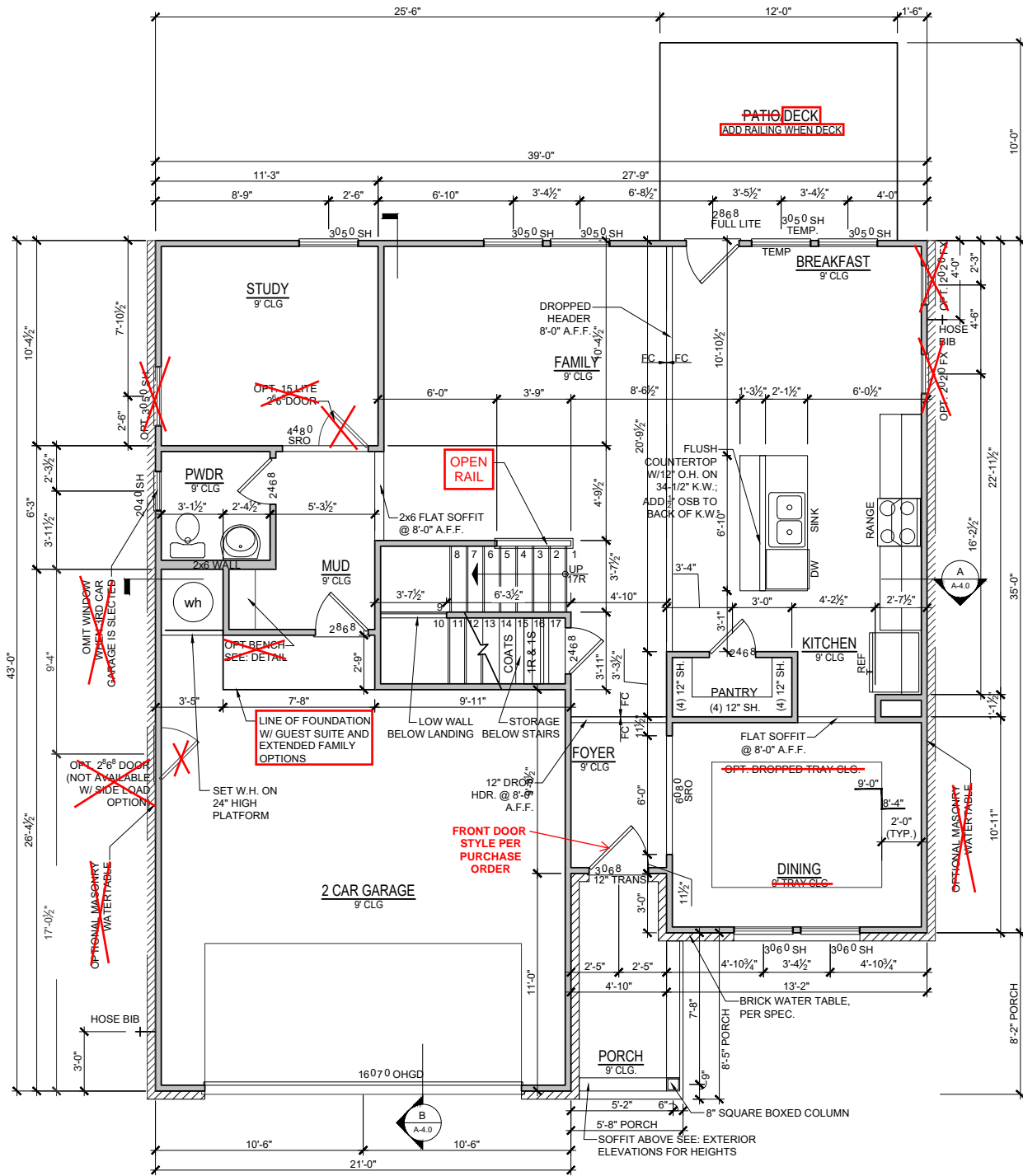

ELEVATION - C
1st FLOOR PLAN
 SCALE: 1/8"=1'-0" (11'x17" SHEET SIZE)
 SCALE: 1/4"=1'-0" (22'x34" SHEET SIZE)

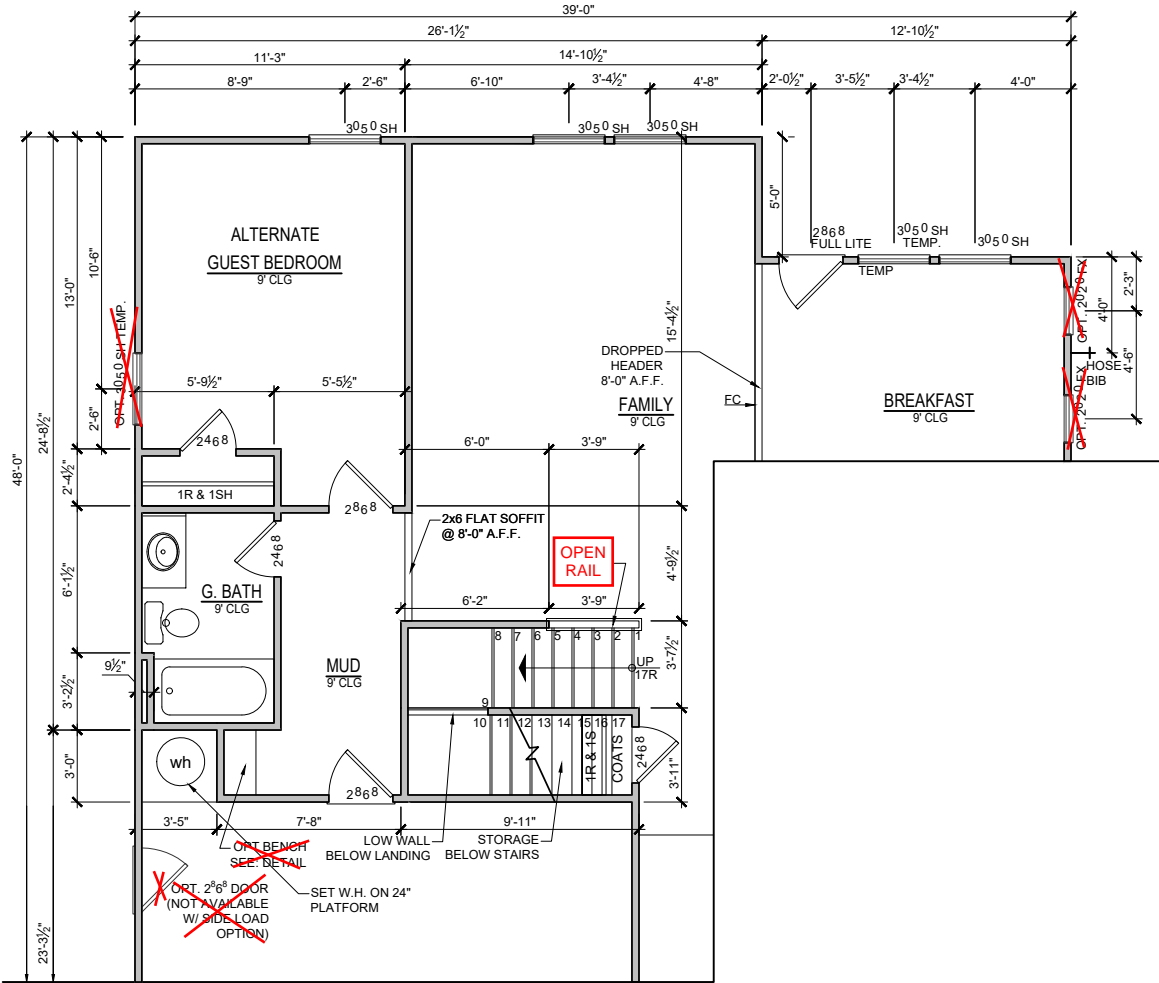

1st FLOOR PLAN
OPT. EXTENDED FAMILY
 SCALE: 1/8"=1'-0" (11'x17" SHEET SIZE)
 SCALE: 1/4"=1'-0" (22'x34" SHEET SIZE)

REVISION NUMBER	DESCRIPTION
7/1/2020	UPDATED SHOWER OPTIONS
10/23/2020	ADDED GAR SVR DR & OPT EXT FAMILY
11/6/2020	ADD OPT PORCHS TO OPT EXT FAMILY
3/30/2021	REVISION TO WH & GARAGE DOORS
02/24/2022	FIX WINDOW SIZE TO 2626 FX ON D
12/12/2024	CHANGED GUEST BED WIC DOOR SWING

MAIN STREET DESIGN
 Main Street Designs of Georgia, LLC
 www.MainStreetDesignsLLC.com
 3050 Royal Blvd, South, Suite 135
 Alpharetta, GA 30022
 O. (404) 966-5722

DAVIDSON HOMES
 Your Community Builder

RELEASE DATE	08-21-2019
PROJECT NUMBER	---
OPTION NO.	---

MODEL	WILLOW
DRAWING TITLE	FIRST FLOOR PLAN
OPTION DESCRIPTION	ELEVATION - C

SHEET NO.
A-1.0C

Wellers Knoll Lot 88

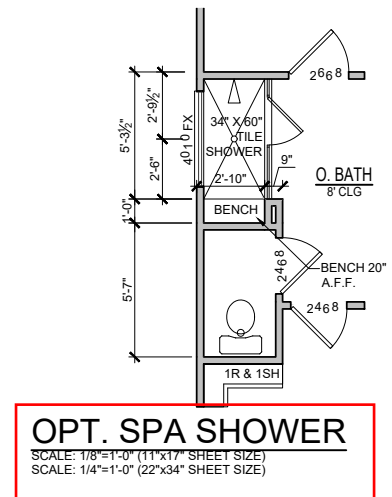
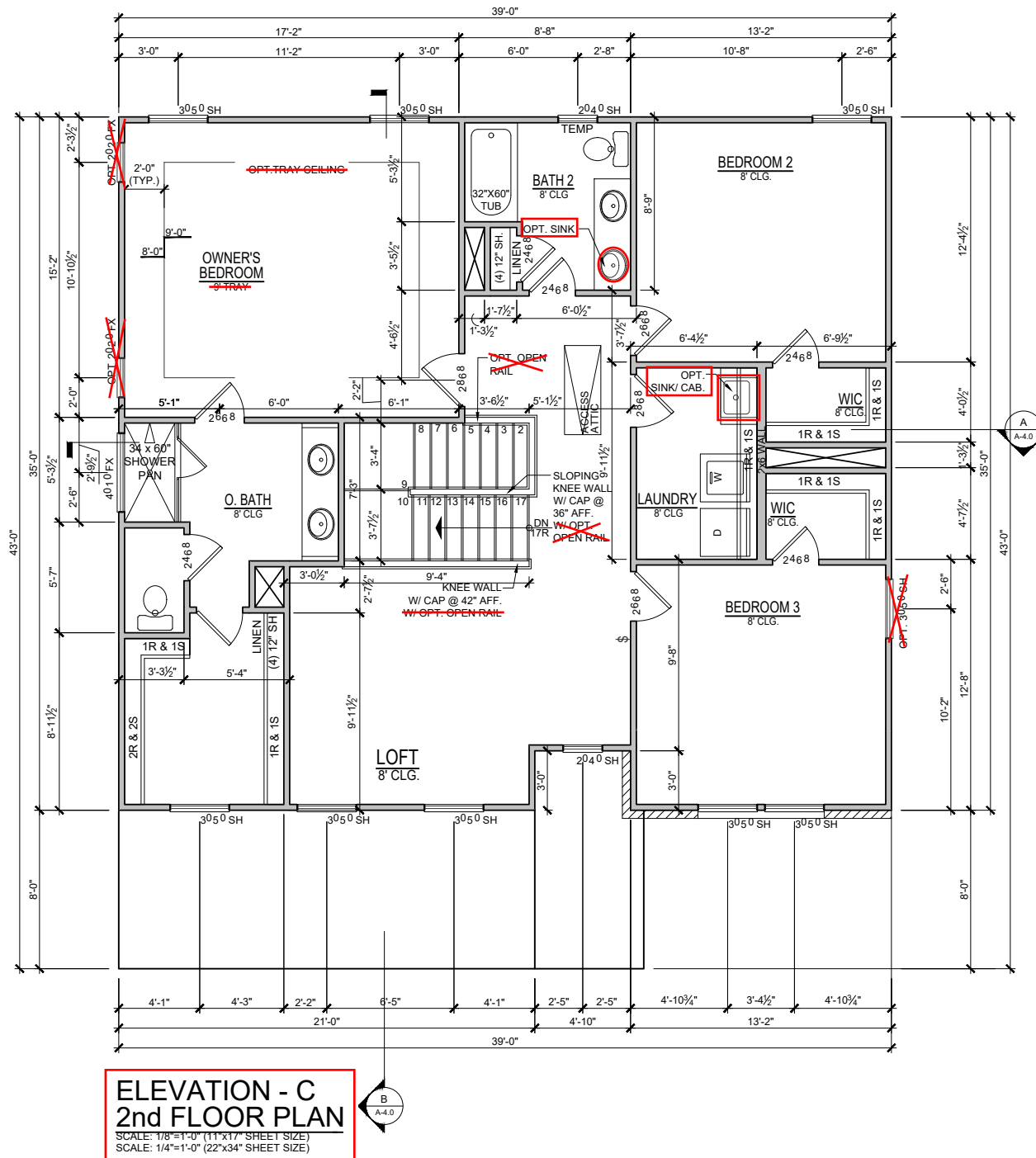

REVISION NUMBER	UPDATED SHOWER OPTIONS
7/1/2020	ADDED GAR SVR DR & OPT EXT FAMILY
10/23/2020	ADD OPT PORCHS TO OPT EXT FAMILY
11/6/2020	REVISION TO WH & GARAGE DOORS
3/30/2021	FIX WINDOW SIZE TO 2626 FX ON D
02/24/2022	CHANGED GUEST BED WIC DOOR SWING

MAIN STREET
 Main Street Designs of Georgia, LLC
 www.MainStreetDesignsLLC.com
 3050 Royal Blvd, South, Suite 135
 Alpharetta, GA 30022
 O. (404) 966-3722

DAVIDSON
 HOMES
 Your Community Builder

RELEASE DATE	08-21-2019
PROJECT NUMBER	---
OPTION NO.	---

MODEL	WILLOW
DRAWING TITLE	SECOND FLOOR PLAN
OPTION DESCRIPTION	ELEVATION - C

SHEET NO.
A-2.0C

Wellers Knoll Lot 88

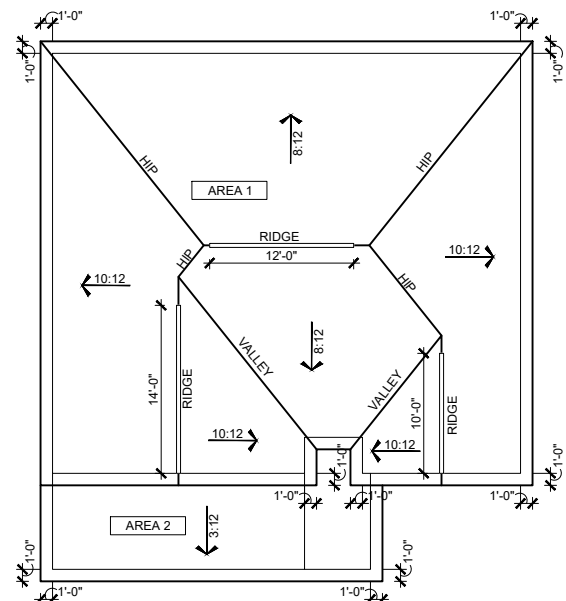

WILLOW ELEVATION - C- ROOF PLAN
SCALE: 1/16"=1'-0" (11"X17" SHEET SIZE)
SCALE: 1/8"=1'-0" (22"X34" SHEET SIZE)

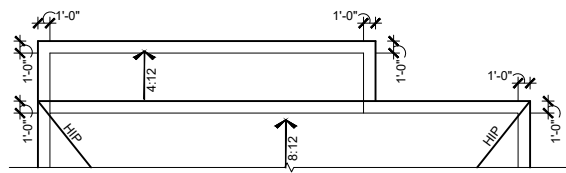

OPT. EXTENDED FAMILY ROOF PLAN
SCALE: 1/16"=1'-0" (11"X17" SHEET SIZE)
SCALE: 1/8"=1'-0" (22"X34" SHEET SIZE)

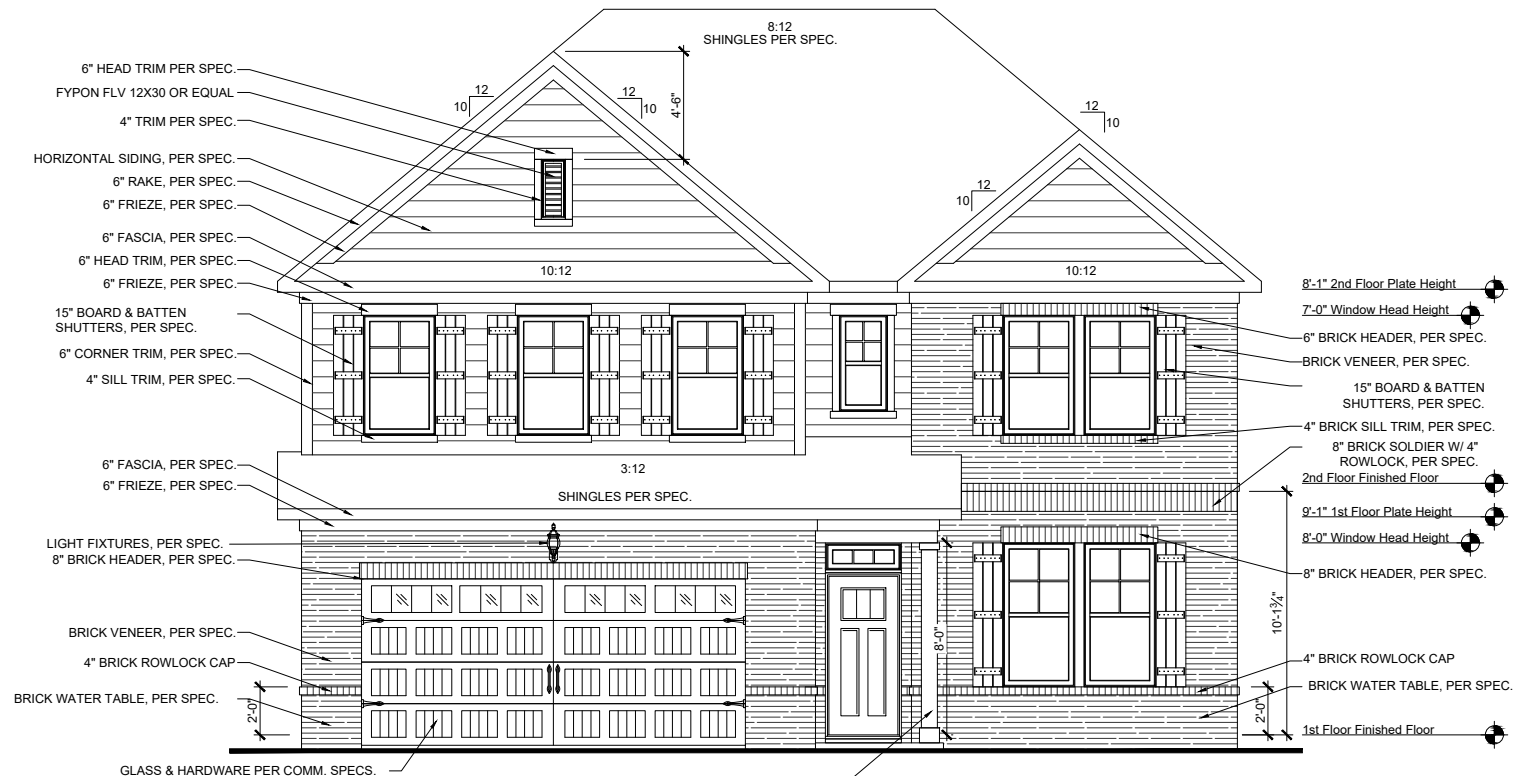

WILLOW FRONT ELEVATION - 'C'
SCALE: 1/8"=1'-0" (11"X17" SHEET SIZE)
SCALE: 1/4"=1'-0" (22"X34" SHEET SIZE)

FRONT DOOR STYLE PER PURCHASE ORDER

ATTIC VENT CALCULATIONS

NOTES:

- GENERAL CONTRACTOR SHALL VERIFY THE NET FREE VENTILATION OF THE VENT PRODUCT SELECTED BY OWNER. VERIFY WITH MANUFACTURER OF HIGH AND LOW VENTS TO BE USED FOR MINIMUM CALCULATED VENTS REQUIRED. THE REQUIRED VENTILATION SHALL BE MAINTAINED. PROVIDE INSULATION STOP SUCH THAT INSULATION DOES NOT OBSTRUCT FREE AIR MOVEMENT AS REQUIRED BY THE BUILDING OFFICIAL.
- ALL OVERLAP FRAMED ROOF AREAS SHALL HAVE OPENINGS BETWEEN THE ADJACENT ATTICS IN THE ROOF SHEATHING (AS ALLOWED BY THE STRUCTURAL ENGINEER) TO ALLOW PASSAGE AND ATTIC VENTILATION BETWEEN THE TWO OR ISOLATED ATTIC SPACES SHALL BE VENTED INDEPENDENTLY TO CBC REQUIREMENTS.
- PER DEVELOPER, AT ALL CANTILEVERED FLOORS, CANTILEVERED ARCHITECTURAL POP-OUTS, AND ANY DOUBLE FRAMING PROJECTIONS THAT ARE SEPARATED FROM THE VENTING CALCULATIONS SHOWN ABOVE, PROVIDE A CONTINUOUS 2" CORROSION RESISTANT SOFFIT VENT AT UNDERSIDE OF FRAMED ELEMENT.
- ALL ROOF DRAINAGE SHALL BE PIPED TO STREET OR APPROVED DRAINAGE FACILITY.
- DASHED LINES INDICATE WALL BELOW.
- LOCATE GUTTER AND DOWNSPOUTS PER BUILDER.
- PITCHED ROOFS AS NOTED.
- TRUSS MANUFACTURER SHALL SUBMIT STRUCTURAL CALCS AND SHOP DRAWINGS TO THE BUILDER'S GENERAL CONTRACTOR AND BUILDING DEPARTMENT FOR REVIEW PRIOR TO FABRICATIONS.
- ALL PLUMBING VENTS SHALL BE COMBINED INTO A MINIMUM AMOUNT OF ROOF PENETRATIONS. ALL ROOF PENETRATIONS SHALL OCCUR TO THE REAR OF THE MAIN RIDGE

MAIN ROOF AREA 1

1350 SQ FT UNDER ROOF ATTIC	300 SQ FT / 1 SQ FT = 4.50 SQ FT VENTILATION
RIDGE VENTS 18 SQ IN = (.125 SQ FT)	SOFFIT VENTS 9 SQ IN = (.0625 SQ FT)
BOX VENTS 50 SQ IN = (.347 SQ FT)	
4.50 SQ FT x 50% = 2.250 SQ FT OF RIDGE	2.250 SQ FT OF SOFFIT
4.50 SQ FT x 50% = 2.250 SQ FT OF SOFFIT	
RIDGE VENT	2.250 SQ FT = 18.0 FEET OF RIDGE VENT
SOFFIT VENT	0.125 SQ FT = 36.0 FEET OF SOFFIT VENT
ACTUAL RIDGE VENT PROVIDED	36 FEET
ACTUAL SOFFIT VENT PROVIDED	115 FEET
NUMBER OF BOX VENTS NEEDED	-6.2 COUNT (NEGATIVE = 0)

AREA 2

168 SQ FT UNDER ROOF	150 SQ FT / 1 SQ FT = 1.12 SQ FT VENTILATION
SOFFIT VENTS 9 SQ IN = (.0625 SQ FT)	ASSUME 100% VENTING @ SOFFIT
SOFFIT VENT	1.120 SQ FT = 17.9 FEET OF SOFFIT VENT
ACTUAL SOFFIT VENT PROVIDED	22 FEET

PORCH ROOF

59 SQ FT UNDER ROOF	150 SQ FT / 1 SQ FT = 0.39 SQ FT VENTILATION
SOFFIT VENTS 9 SQ IN = (.0625 SQ FT)	ASSUME 100% VENTING @ SOFFIT
SOFFIT VENT	0.393 SQ FT = 6.3 FEET OF SOFFIT VENT
ACTUAL SOFFIT VENT PROVIDED	6 FEET

ATTIC VENT CALCULATIONS

MAIN ROOF

1518 SQ FT UNDER ROOF ATTIC	300 SQ FT / 1 SQ FT = 5.06 SQ FT VENTILATION
RIDGE VENTS 18 SQ IN = (.125 SQ FT)	SOFFIT VENTS 9 SQ IN = (.0625 SQ FT)
BOX VENTS 50 SQ IN = (.347 SQ FT)	
5.06 SQ FT x 50% = 2.530 SQ FT OF RIDGE	2.530 SQ FT OF SOFFIT
5.06 SQ FT x 50% = 2.530 SQ FT OF SOFFIT	
RIDGE VENT	2.530 SQ FT = 20.2 FEET OF RIDGE VENT
SOFFIT VENT	0.125 SQ FT = 40.5 FEET OF SOFFIT VENT
ACTUAL RIDGE VENT PROVIDED	40 FEET
ACTUAL SOFFIT VENT PROVIDED	140 FEET
NUMBER OF BOX VENTS NEEDED	-6.9 COUNT (NEGATIVE = 0)

FLEX ROOF

131 SQ FT UNDER ROOF	150 SQ FT / 1 SQ FT = 0.87 SQ FT VENTILATION
SOFFIT VENTS 9 SQ IN = (.0625 SQ FT)	ASSUME 100% VENTING @ SOFFIT
SOFFIT VENT	0.873 SQ FT = 14.0 FEET OF SOFFIT VENT
ACTUAL SOFFIT VENT PROVIDED	26 FEET



OPT. EXTENDED FAMILY REAR ELEVATION
SCALE: 1/8"=1'-0" (11"X17" SHEET SIZE)
SCALE: 1/4"=1'-0" (22"X34" SHEET SIZE)

BRICK FOUNDATION PER COMM. SPECS.

REVISION NUMBER	DATE	DESCRIPTION
7/1/2020	UPDATED SHOWER OPTIONS	
10/23/2020	ADDED GAR SVR DR & OPT EXT FAMILY	
11/6/2020	ADD OPT PORCHS TO OPT EXT FAMILY	
3/30/2021	REVISION TO WH & GARAGE DOORS	
02/24/2022	FIX WINDOW SIZE TO 2626 FX ON D	
12/12/2024	CHANGED GUEST BED WIC DOOR SWING	

MAIN STREET DESIGN
Main Street Designs of Georgia, LLC
www.MainStreetDesignsLLC.com
3050 Royal Blvd, South, Suite 135
Alpharetta, GA 30022
O. (404) 966-9722

DAVIDSON HOMES
Your Community Builder

MODEL	WILLOW
DRAWING TITLE	EXT. ELEV/ ROOF PLAN
OPTION DESCRIPTION	ELEVATION - C
RELEASE DATE	08-21-2019
PROJECT NUMBER	---
OPTION NO.	---

SHEET NO. **A-3.0C**

Wellers Knoll Lot 88

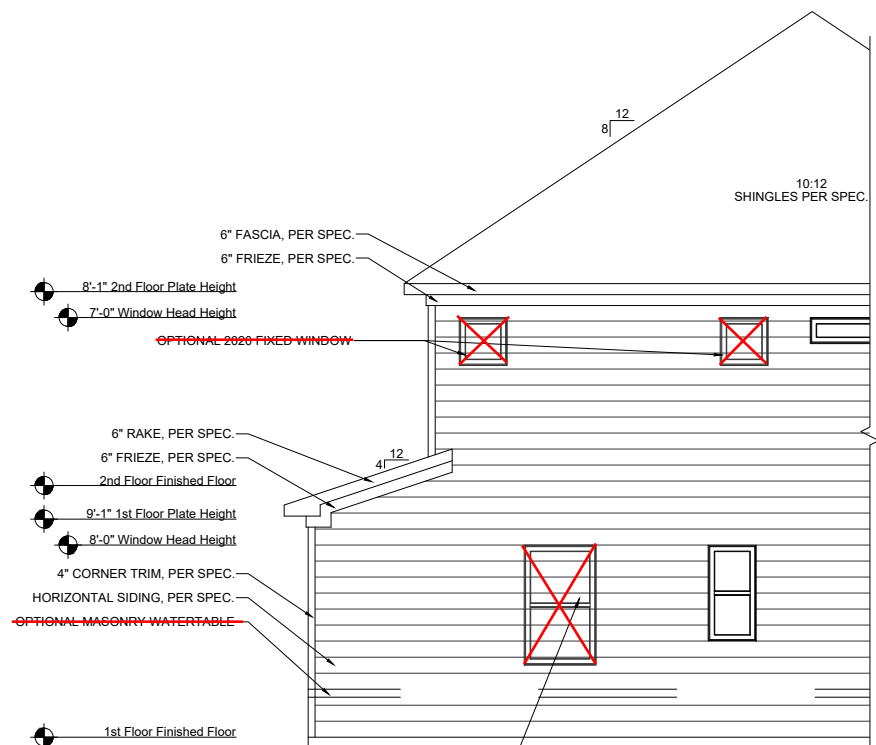

OPT. EXTENDED FAMILY LEFT ELEVATION
 SCALE: 1/8"=1'-0" (11"x17" SHEET SIZE)
 SCALE: 1/4"=1'-0" (22"x34" SHEET SIZE)

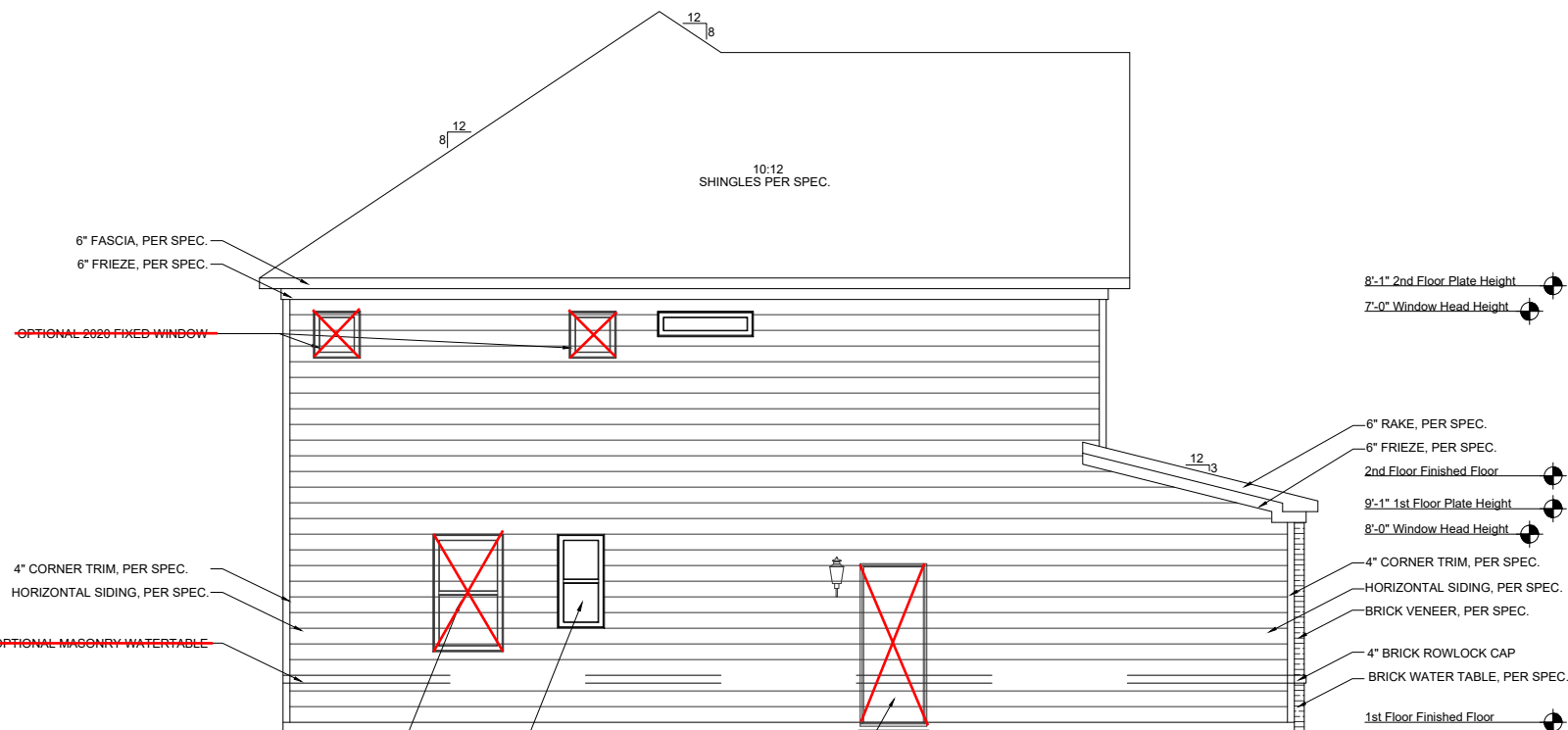

WILLOW LEFT ELEVATION - 'C'
 SCALE: 1/8"=1'-0" (11"x17" SHEET SIZE)
 SCALE: 1/4"=1'-0" (22"x34" SHEET SIZE)

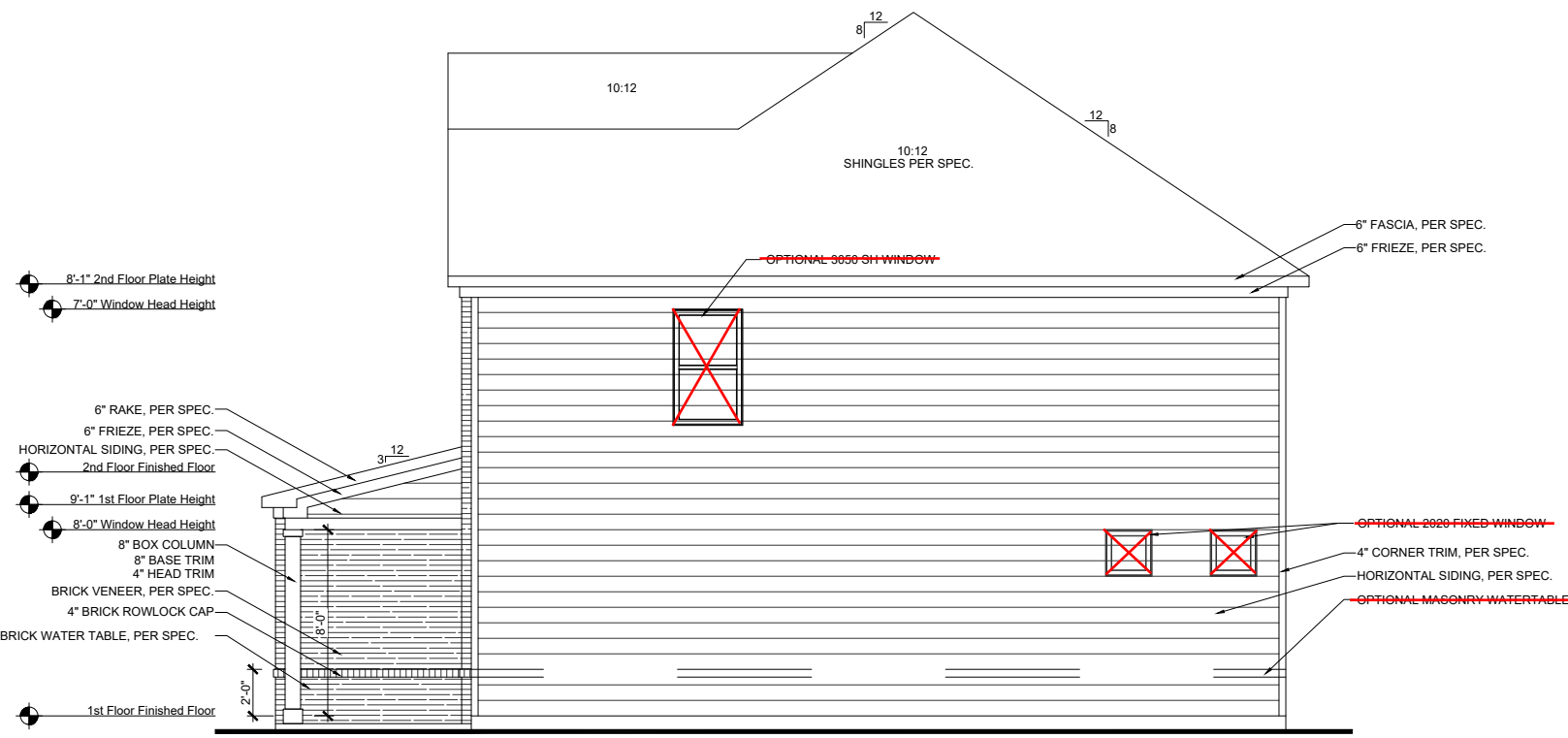

WILLOW RIGHT ELEVATION - 'C'
 SCALE: 1/8"=1'-0" (11"x17" SHEET SIZE)
 SCALE: 1/4"=1'-0" (22"x34" SHEET SIZE)

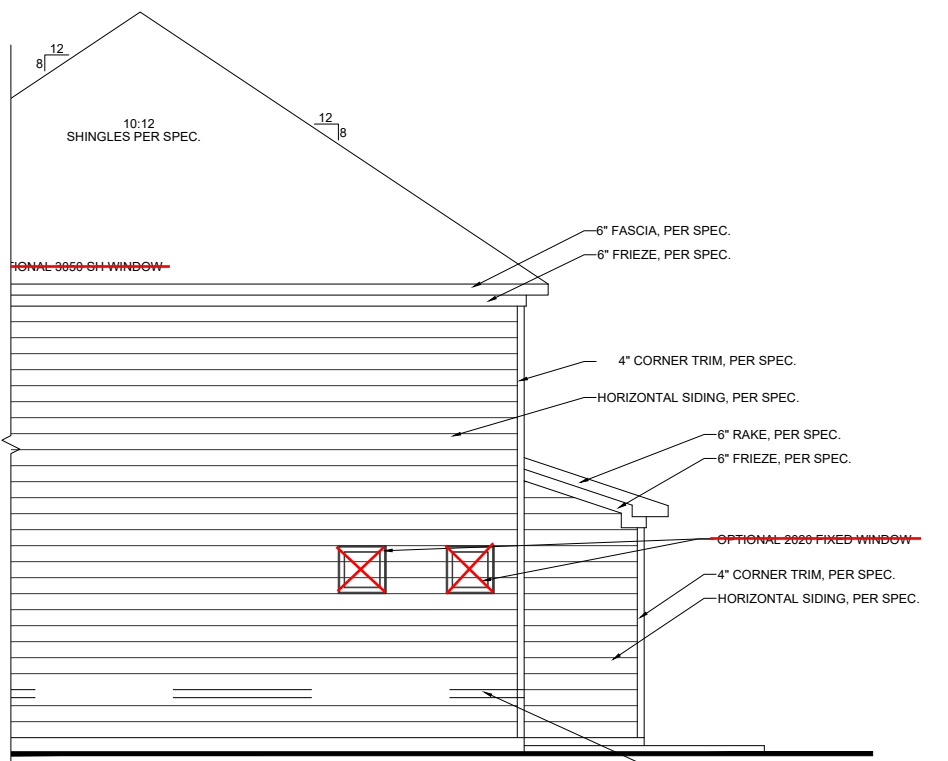

OPT. EXTENDED FAMILY RIGHT ELEVATION
 SCALE: 1/8"=1'-0" (11"x17" SHEET SIZE)
 SCALE: 1/4"=1'-0" (22"x34" SHEET SIZE)

REVISION NUMBER	UPDATED SHOWER OPTIONS
7/1/2020	
10/23/2020	ADDED GAR SVR DR & OPT EXT FAMILY
11/6/2020	ADD OPT PORCHS TO OPT EXT FAMILY
3/30/2021	REVISION TO WH & GARAGE DOORS
02/24/2022	FIX WINDOW SIZE TO 2626 FX ON D
12/12/2024	CHANGED GUEST BED WIC DOOR SWING

MAIN STREET DESIGN
 Main Street Designs of Georgia, LLC
 www.MainStreetDesignsLLC.com
 3050 Royal Blvd, South, Suite 135
 Alpharetta, GA 30022
 O. (404) 966-9722

DAVIDSON HOMES
 Your Community Builder

MODEL	WILLOW
DRAWING TITLE	SIDE ELEVATIONS
OPTION DESCRIPTION	ELEVATION - C
RELEASE DATE	08-21-2019
PROJECT NUMBER	---
OPTION NO.	---
SHEET NO.	A-3.1C

Wellers Knoll Lot 88

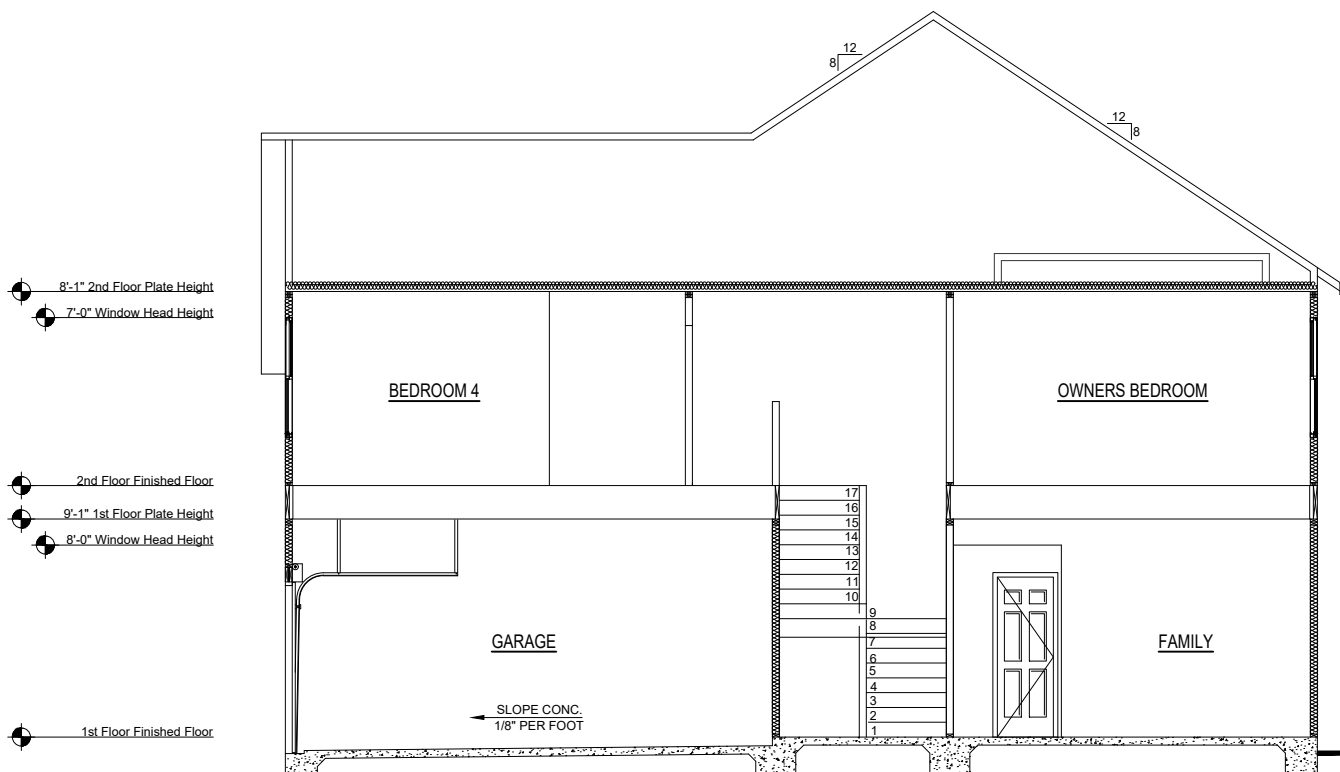

SECTION - B
 SCALE: 1/8"=1'-0" (11"X17" SHEET SIZE)
 SCALE: 1/4"=1'-0" (22"X34" SHEET SIZE)

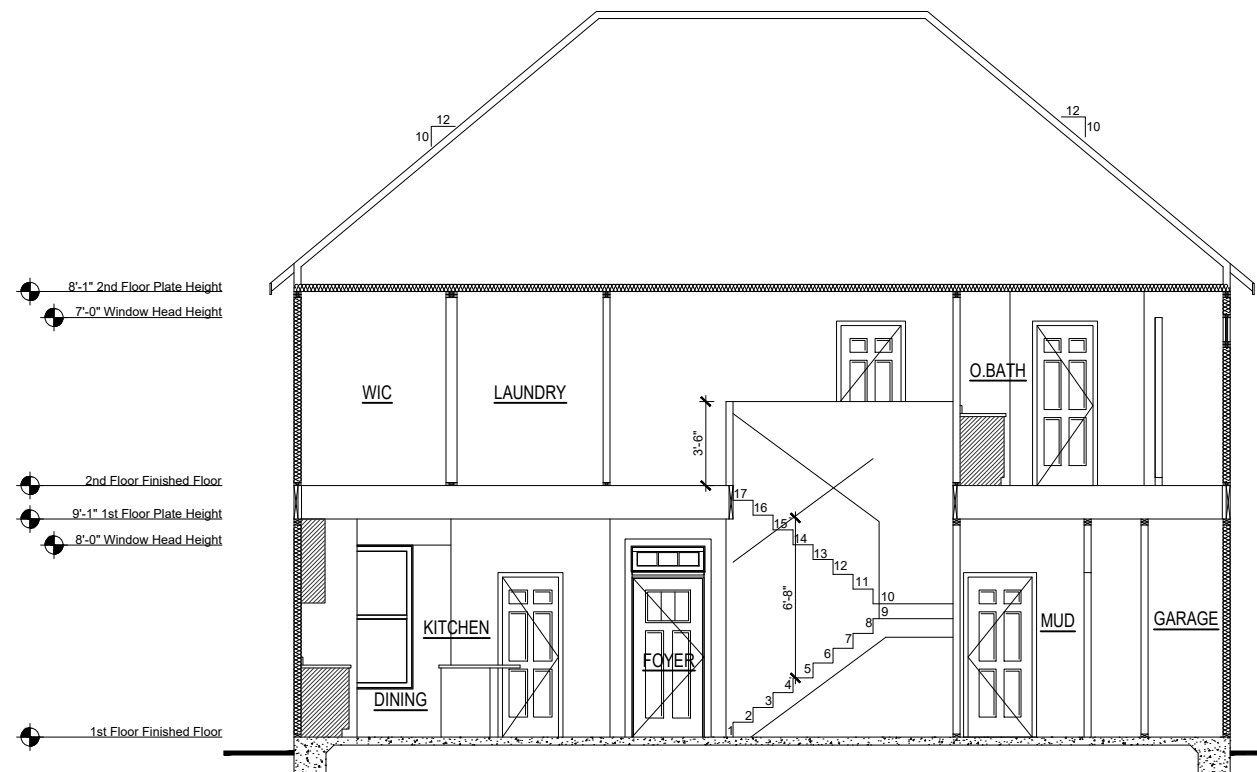

SECTION - A
 SCALE: 1/8"=1'-0" (11"X17" SHEET SIZE)
 SCALE: 1/4"=1'-0" (22"X34" SHEET SIZE)

REVISION NUMBER	DESCRIPTION
7/1/2020	UPDATED SHOWER OPTIONS
10/23/2020	ADDED GAR SVR DR & OPT EXT FAMILY
11/6/2020	ADD OPT PORCHS TO OPT EXT FAMILY
3/30/2021	REVISION TO WH & GARAGE DOORS
02/24/2022	FIX WINDOW SIZE TO 2626 FX ON D
12/12/2024	CHANGED GUEST BED WIC DOOR SWING





































MAIN STREET
 Main Street Designs of Georgia, LLC
 www.MainStreetDesignsLLC.com
 3150 Royal Blvd, South, Suite 135
 Alpharetta, GA 30022
 O. (404) 996-5722

DAVIDSON HOMES
 Your Community Builder

MODEL	WILLOW
DRAWING TITLE	BUILDING SECTIONS
OPTION DESCRIPTION	
RELEASE DATE	08-21-2019
PROJECT NUMBER	---
OPTION NO.	---
SHEET NO.	A-4.0C

Wellers Knoll Lot 88

ELECTRICAL KEY

-  CEILING RECEP.
-  DUPLEX RECEP.
-  SPLIT SWITCHED RECEP.
-  FLOOR RECEP.
-  QUADPLEX RECEP.
-  GFI GROUND FAULT RECEP.
-  GFI/WP WEATHER PROOF RECEP.
-  220V 220v RECEP.
-  EXHAUST FAN
-  EXHAUST FAN / LIGHT
-  EXHAUST FAN / HEAT LIGHT
-  LED
-  VAPOR PROTECTED LIGHT
-  CEILING LIGHT
-  HANGING CEILING LIGHT
-  WALL LIGHT
-  WALL SCONCE LIGHT
-  SINGLE SWITCH
-  3-WAY SWITCH
-  4-WAY SWITCH
-  DIMMER SWITCH
-  CABLE T.V. JACK
-  BUTTON
-  PHONE JACK
-  DIRECT WIRE
-  SECURITY SYSTEM PHONE JACK
-  SMOKE DETECTOR
-  CARBON MONOXIDE DETECTOR
-  ELECTRICAL PANEL
-  DISCONNECT SWITCH
-  ELECTRIC METER
-  1 TUBE FLUORESCENT
-  2 TUBE FLUORESCENT
-  FLOOD LIGHT
-  CHIMES
-  CEILING FAN
-  CEILING FAN W/ LIGHT

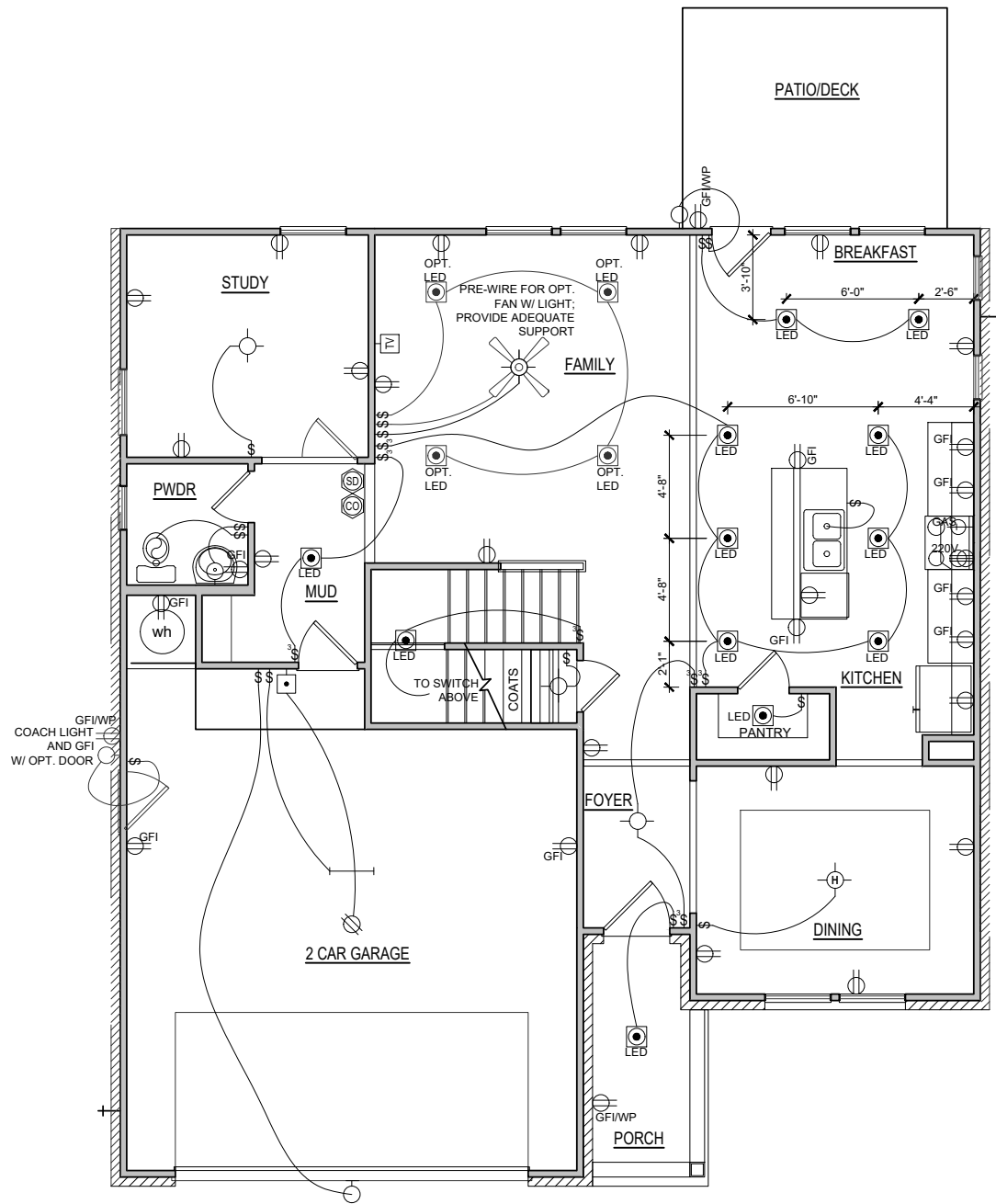

**ELEVATION - C
FIRST FLOOR ELECTRICAL PLAN**
SCALE: 1/8"=1'-0" (11"x17" SHEET SIZE)
SCALE: 1/4"=1'-0" (22"x34" SHEET SIZE)

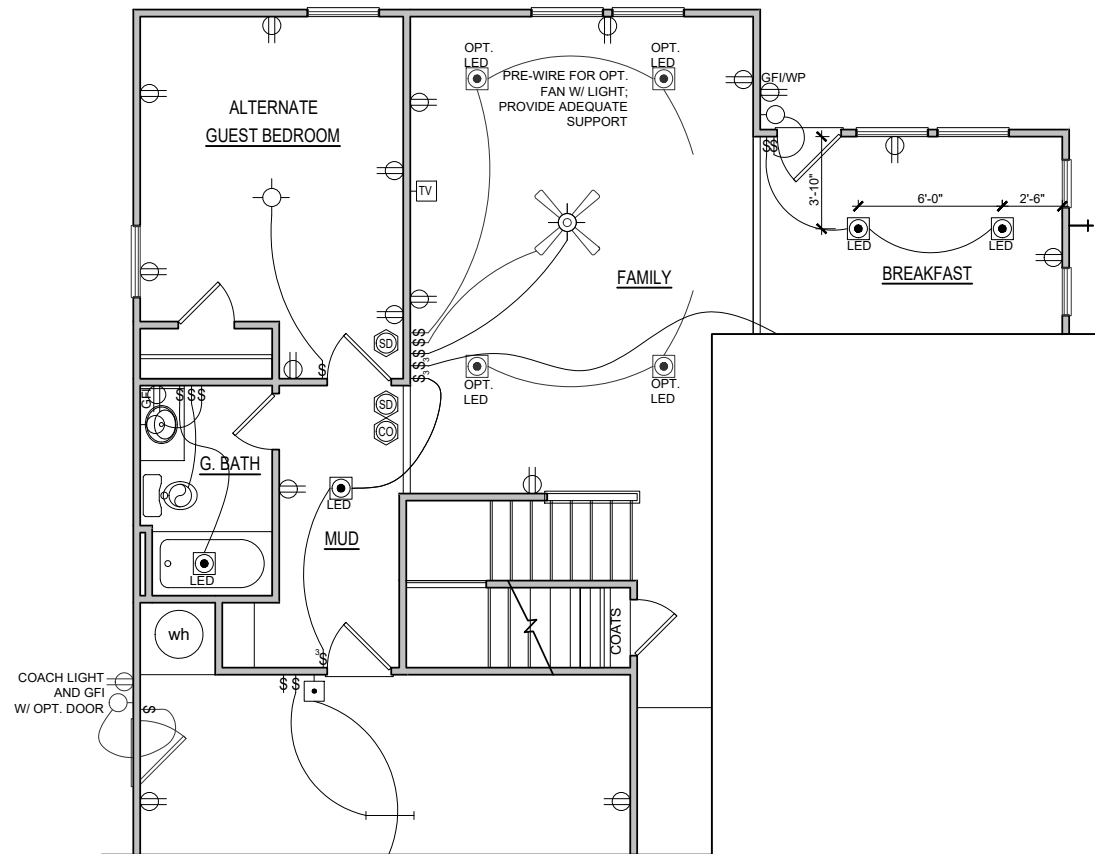

**ELECTRICAL PLAN
OPT. EXTENDED FAMILY**
SCALE: 1/8"=1'-0" (11"x17" SHEET SIZE)
SCALE: 1/4"=1'-0" (22"x34" SHEET SIZE)

REVISION NUMBER	DESCRIPTION
7/1/2020	UPDATED SHOWER OPTIONS
10/23/2020	ADDED GAR SVR DR & OPT EXT FAMILY
11/6/2020	ADD OPT PORCHS TO OPT EXT FAMILY
3/30/2021	REVISION TO WH & GARAGE DOORS
02/24/2022	FIX WINDOW SIZE TO 2626 FX ON D
12/12/2024	CHANGED GUEST BED WIC DOOR SWING

MAIN STREET DESIGN
Main Street Designs of Georgia, LLC
www.MainStreetDesignsLLC.com
3050 Royal Blvd, South, Suite 135
Alpharetta, GA 30022
O. (404) 996-9722

DAVIDSON HOMES
Your Community Builder

MODEL	WILLOW
RELEASE DATE	08-21-2019
DRAWING TITLE	1ST FLOOR ELEC. PLAN
PROJECT NUMBER	-----
OPTION NO.	ELEVATION - C

SHEET NO.
E-1.0C

SCALE NOTE:
LARGE FORMAT PRINTS ARE TO SCALE AS NOTED.
11" x 17" PRINTS ARE ONE HALF THE NOTED SCALE

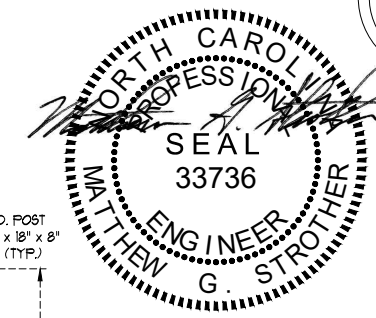

10/16/2024

J.S. THOMPSON ENGINEERING, INC
333 EAST SIX FORKS ROAD, SUITE 180, RALEIGH, NC 27609
PHONE: (919) 7899919 FAX: (919) 7899921
N.C. LICENSE NO.: C1733

WILLOW
DAVIDSON HOMES

120 MPH ULTIMATE DESIGN WIND SPEED
NOTES FOR LESS THAN
30' MEAN ROOF HEIGHT:

- ENGINEER'S SEAL APPLIES ONLY TO STRUCTURAL COMPONENTS. ENGINEER'S SEAL DOES NOT CERTIFY DIMENSIONAL ACCURACY OR ARCHITECTURAL LAYOUT INCLUDING ROOF SYSTEM.
- STRUCTURAL DESIGN PER NORTH CAROLINA RESIDENTIAL CODE, 2018 EDITION.
- INSTALL 1/2" ANCHOR BOLTS 6'-0" O.C. AND WITHIN 1'-0" FROM END OF EACH CORNER. ANCHOR BOLTS MUST EXTEND A MINIMUM OF 1" INTO MASONRY OR CONCRETE. LOCATE BOLT WITHIN MIDDLE THIRD OF PLATE WIDTH. MEAN ROOF HEIGHT IS LESS THAN 30 FEET.
- EXTERIOR WALLS DESIGNED FOR 120 MPH WINDS.
- WALL CLADDING DESIGNED FOR -8.5 PSF AND -20 PSF (+/- INDICATE POSITIVE / NEGATIVE PRESSURE (TYP)).
- ROOF CLADDING DESIGNED FOR +4.2 PSF AND -18 PSF FOR ROOF PITCHES 1/2 TO 12/12 AND +0 PSF AND -36 PSF FOR ROOF PITCHES 225/12 TO 1/12.
- INSTALL 1/8" OSB SHEATHING ON ALL EXTERIOR WALLS OF ALL STOREYS IN ACCORDANCE WITH SECTION R602.10.3 OF THE NRC, 2018 EDITION. SEE THE WALL BRACING NOTES AND DETAILS SHEET FOR MORE INFORMATION.
- ENERGY EFFICIENCY COMPLIANCE AND INSULATION VALUES OF THE BUILDING TO BE IN ACCORDANCE WITH CHAPTER 11 OF THE NRC, 2018 EDITION.
- REFER TO NOTES AND DETAIL SHEETS FOR ADDITIONAL STRUCTURAL INFORMATION.

STRUCTURAL NOTES:

- ALL FRAMING LUMBER TO BE #2 SPP OR #2 SYP (UNO). ALL TREATED LUMBER TO BE #2 SYP (UNO).
- INSTALL A DOUBLE OR TRIPLE JOIST UNDER WALLS PARALLEL TO FLOOR JOISTS WHERE NOTED ON THE PLANS.
- SQUARES DENOTE POINT LOADS WHICH REQUIRE SOLID BLOCKING TO GIRDER OR FOUNDATION.
- SHADED PIERS TO BE FILLED SOLID.
- INSTALL LADDER WIRE # 16" O.C. TO SECURE MULTIPLE WYTHE FOUNDATION WALLS TOGETHER.
- REFER TO NOTES AND DETAIL SHEETS FOR ADDITIONAL STRUCTURAL INFORMATION.

LEGEND	
CONT	CONTINUOUS
XJ	EXTRA JOIST
DJ	DOUBLE JOIST
TJ	TRIPLE JOIST
EA	EACH
FDN	FOUNDATION
FTG	FOOTING
OC	ON CENTER
SPF	SPRUCE PINE FIR
SYP	SOUTHERN YELLOW PINE
TRTD	PRESSURE TREATED
TYP	TYPICAL
UNO	UNLESS NOTED OTHERWISE

DATE: OCTOBER 16, 2024
SCALE: 1/4" = 1'-0"
DRAWN BY: MAIN STREET DESIGN
ENGINEERED BY: ZHH

S-1.1j
CRAWL FOUNDATION
PLAN w/ OPT. 2 x 10 JOISTS

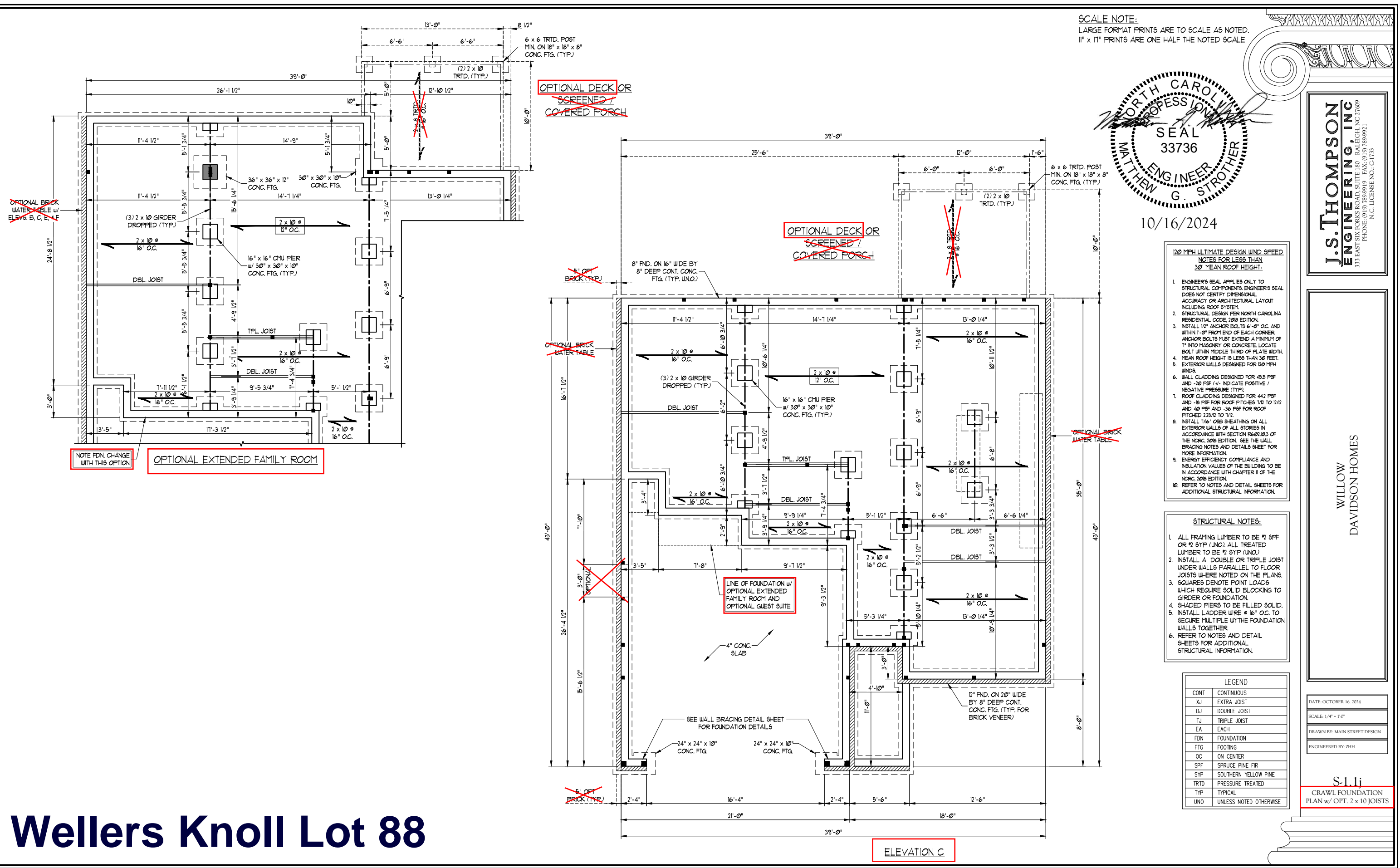

Wellers Knoll Lot 88

ELEVATION C

Wellers Knoll Lot 88

SCALE NOTE:
LARGE FORMAT PRINTS ARE TO SCALE AS NOTED.
11" x 17" PRINTS ARE ONE HALF THE NOTED SCALE

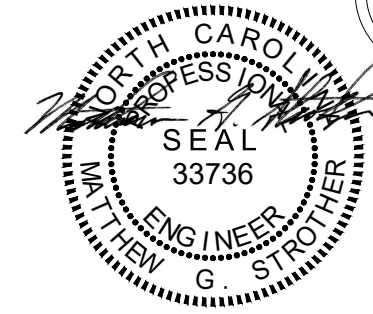

10/16/2024

J.S. THOMPSON
ENGINEERING, INC.
333 EAST SIX FORKS ROAD, SUITE 180, RALEIGH, NC 27609
PHONE: (919) 7899919 FAX: (919) 7899921
N.C. LICENSE NO.: C-1733

WILLOW
DAVIDSON HOMES

BRACED WALL DESIGN NOTES:

- BRACED WALL DESIGN PER SECTION R602.10.5 "WALL BRACING BY ENGINEERED DESIGN" OF THE NRC 2018 EDITION USING BRACING MATERIALS AND METHODS LISTED IN TABLE R602.10.1 ALONG WITH ALTERNATIVE MATERIALS AND METHODS THAT COMPLY WITH ACCEPTED ENGINEERING PRACTICE. BRACED WALL DESIGN IS NOT PRESCRIPTIVE.
- SHEATH ALL EXTERIOR WALLS w/ 7/16" OSB TO PROVIDE CS-WSP WALL BRACING THAT WILL BRACE THE STRUCTURE FOR ALL LATERAL LOADS AS REQUIRED BY THE NRC 2018 EDITION.
- CS-WSP REFERS TO "CONTINUOUSLY SHEATHED WOOD STRUCTURAL PANELS." CONTRACTOR IS TO INSTALL 7/16" OSB ON ALL EXTERIOR WALLS ATTACHED w/ 8d NAILS SPACED 6" O.C. ALONG PANEL EDGES AND 12" O.C. IN THE FIELD.
- GB REFERS TO "GYPSUM BOARD." CONTRACTOR IS TO INSTALL 1/2" (MIN.) GYPSUM BOARD ON BOTH SIDES OF WALL WHERE NOTED ON THE PLANS ATTACHED WITH 1 1/4" LONG #6 SCREWS OR 1 5/8" LONG 5d COOLER NAILS SPACED 7" O.C. ALONG PANEL EDGES AND IN THE FIELD.
- BRACED WALL DESIGN APPLIED IN WIND ZONES UP TO 130 MPH. FOR HIGH WIND ZONES, BRACED WALLS ARE TO BE CONSTRUCTED IN ACCORDANCE WITH CHAPTER 45 OF THE NRC 2018 EDITION.
- SEE NOTES AND DETAIL SHEETS FOR ADDITIONAL BRACED WALL INFORMATION.

STRUCTURAL NOTES:

- ALL FRAMING LUMBER TO BE SPP #2 OR SYP #2 (UNO). ALL TREATED LUMBER TO BE SYP #2 (UNO).
- ALL LOAD BEARING HEADERS TO BE (2) 2 x 6 SPP #2 OR SYP #2 (KILN DRIED) (UNO). HEADERS HAVE BEEN DESIGNED BASED ON CALCULATED LOADS. CODE TABLES HAVE NOT BEEN USED.
- INSTALL AN EXTRA JOIST UNDER WALLS PARALLEL TO FLOOR JOISTS WHERE NOTED ON THE PLANS.
- WINDOW AND DOOR HEADERS TO BE SUPPORTED w/ (1) JACK STUD AND (1) KING STUD EA. END (UNO). SEE TABLE R602.15 FOR ADDITIONAL KING STUD REQUIREMENTS.
- SQUARES DENOTE POINT LOADS WHICH REQUIRE SOLID BLOCKING TO GIRDER OR FOUNDATION. ALL SQUARES TO BE (2) STUDS (UNO).
- ALL 4 x 4 POSTS SHALL BE ANCHORED TO SLABS w/ SIMPSON ABU44 POST BASES (OR EQUAL) AND 6 x 6 POSTS w/ ABU66 POST BASES (OR EQUAL) (UNO). ALL 4 x 4 AND 6 x 6 POSTS TO BE INSTALLED WITH 100 LB CAPACITY UPLIFT CONNECTORS AT TOP (UNO).
- FOR FIBERGLASS, ALUMINUM, OR COLUMN ENG. BY OTHERS, SECURE TO SLAB w/ (2) METAL ANGLES USING 2" CONC. SCREWS. FASTEN ANGLES TO COLUMNS w/ 1/4" THROUGH BOLTS w/ NUTS AND WASHERS. LOCATE ANGLES ON OPPOSITE SIDES OF COLUMN. THROUGH BOLTS MUST BE INSTALLED PRIOR TO SETTING COLUMN. REFER TO NOTES AND DETAIL SHEETS FOR ADDITIONAL STRUCTURAL INFORMATION.

TABLE R602.7.5

MINIMUM NUMBER OF FULL HEIGHT KING STUDS AT EACH END OF HEADERS IN EXTERIOR WALLS

HEADER SPAN (FEET)	MINIMUM NUMBER OF FULL HEIGHT STUDS (KINGS)
UP TO 3'	1
> 3' TO 6'	2
> 6' TO 9'	3
> 9' TO 12'	4
> 12' TO 15'	5

NOTE:

BCI 5000#-18 JOISTS MAY BE USED IN LIEU OF TJI 210 JOISTS AT THE DEPTH AND SPACING INDICATED ON THE PLANS.

LEGEND

CONT	CONTINUOUS
XT	EXTRA TRUSS
XJ	EXTRA JOIST
DJ	DOUBLE JOIST
TJ	TRIPLE JOIST
EA	EACH
()	NUMBER OF STUDS
DSP	DOUBLE STUD POCKET
TSP	TRIPLE STUD POCKET
OC	ON CENTER
SPF	SPRUCE PINE FIR
SYP	SOUTHERN YELLOW PINE
TRTD	PRESSURE TREATED
TYP	TYPICAL
UNO	UNLESS NOTED OTHERWISE

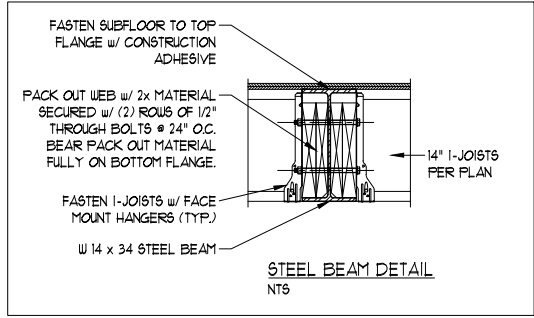
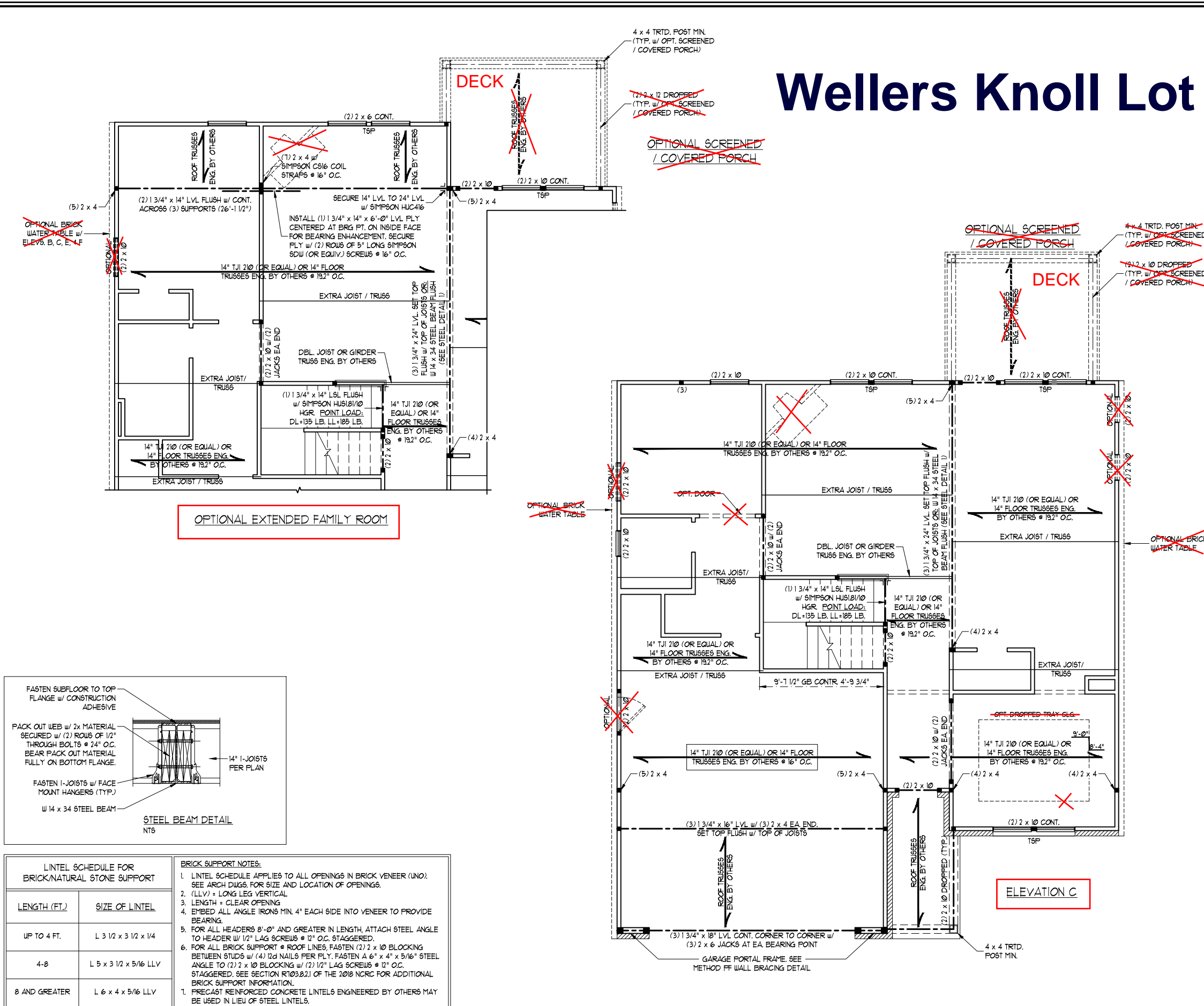

LINTEL SCHEDULE FOR BRICK/NATURAL STONE SUPPORT

LENGTH (FT.)	SIZE OF LINTEL
UP TO 4 FT.	L 3 1/2 x 3 1/2 x 1/4
4-8	L 5 x 3 1/2 x 5/16 LLV
8 AND GREATER	L 6 x 4 x 5/16 LLV

- BRICK SUPPORT NOTES:**
- LINTEL SCHEDULE APPLIES TO ALL OPENINGS IN BRICK VENEER (UNO). SEE ARCH DRGS. FOR SIZE AND LOCATION OF OPENINGS.
 - (LLV) = LONG LEG VERTICAL
 - LENGTH = CLEAR OPENING
 - EMBED ALL ANGLE IRONS MIN. 4" EACH SIDE INTO VENEER TO PROVIDE BEARING.
 - FOR ALL HEADERS 8'-0" AND GREATER IN LENGTH, ATTACH STEEL ANGLE TO HEADER w/ 1/2" LAG SCREWS @ 12" O.C. STAGGERED.
 - FOR ALL BRICK SUPPORT @ ROOF LINES, FASTEN (2) 2 x 10 BLOCKING BETWEEN STUDS w/ (4) 12d NAILS PER PLY. FASTEN A 6" x 4" x 5/16" STEEL ANGLE TO (2) 2 x 10 BLOCKING w/ (2) 1/2" LAG SCREWS @ 12" O.C. STAGGERED. SEE SECTION R103.8.2.1 OF THE 2018 NRC FOR ADDITIONAL BRICK SUPPORT INFORMATION.
 - PRECAST REINFORCED CONCRETE LINTELS ENGINEERED BY OTHERS MAY BE USED IN LIEU OF STEEL LINTELS.

SCALE NOTE:
LARGE FORMAT PRINTS ARE TO SCALE AS NOTED.
11" x 17" PRINTS ARE ONE HALF THE NOTED SCALE

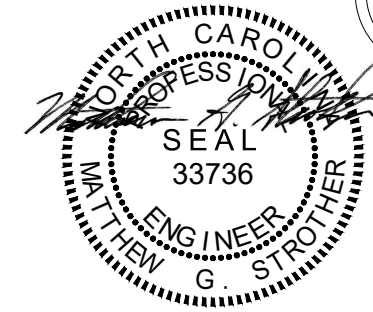

10/16/2024

J.S. THOMPSON ENGINEERING, INC
333 EAST SIX FORKS ROAD, SUITE 180, RALEIGH, NC 27609
PHONE: (919) 7899919 FAX: (919) 7899921
N.C. LICENSE NO.: C1733

WILLOW
DAVIDSON HOMES

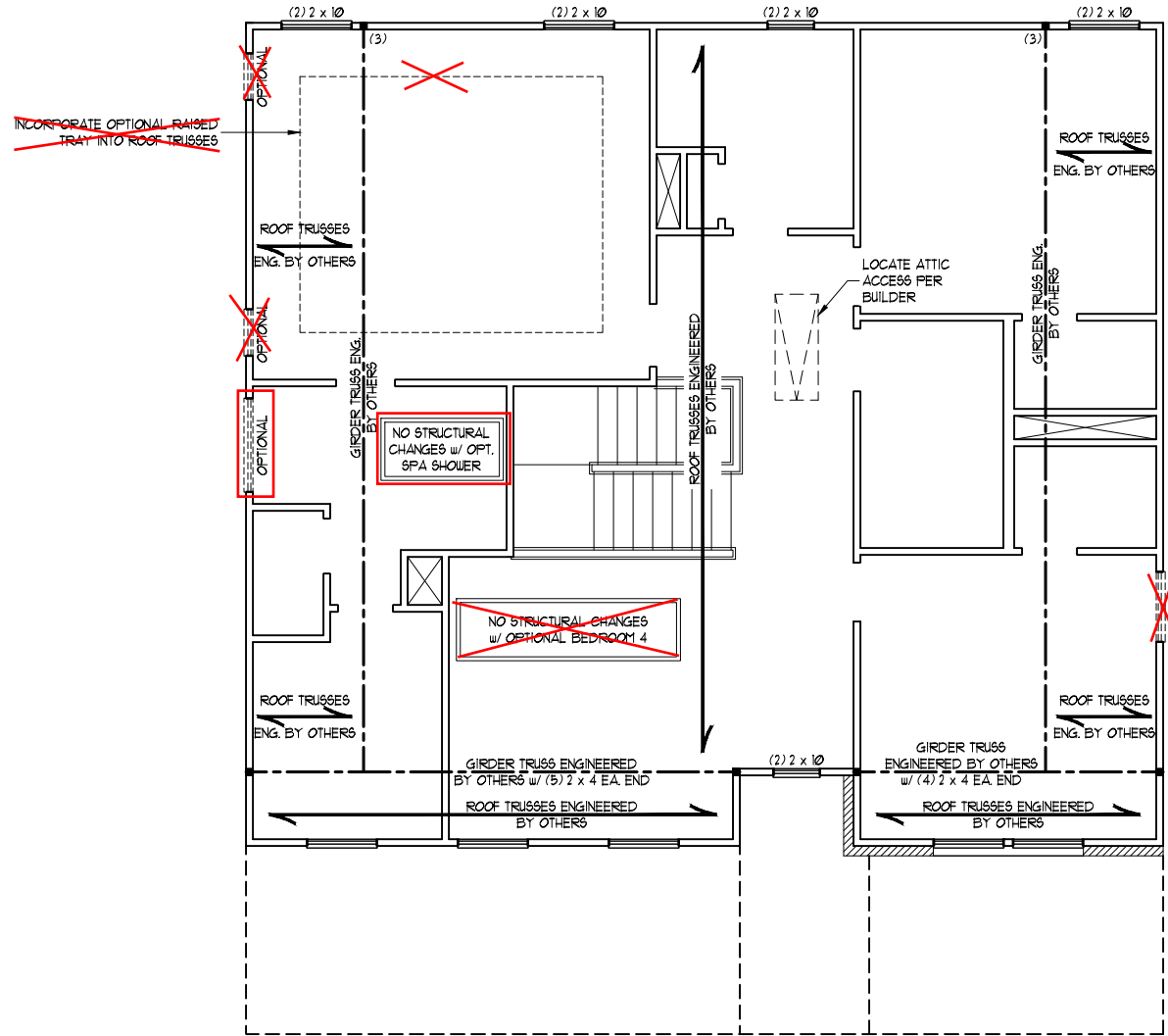

ELEVATION C

- BRACED WALL DESIGN NOTES:**
- BRACED WALL DESIGN PER SECTION R602.10.5 "WALL BRACING BY ENGINEERED DESIGN" OF THE NRC 2018 EDITION USING BRACING MATERIALS AND METHODS LISTED IN TABLE R602.10.1 ALONG WITH ALTERNATIVE MATERIALS AND METHODS THAT COMPLY WITH ACCEPTED ENGINEERING PRACTICE. BRACED WALL DESIGN IS NOT PRESCRIPTIVE.
 - SHEATH ALL EXTERIOR WALLS w/ 7/16" OSB TO PROVIDE CS-WSP WALL BRACING THAT WILL BRACE THE STRUCTURE FOR ALL LATERAL LOADS AS REQUIRED BY THE NRC 2018 EDITION.
 - CS-WSP REFERS TO "CONTINUOUSLY SHEATHED WOOD STRUCTURAL PANELS." CONTRACTOR IS TO INSTALL 7/16" OSB ON ALL EXTERIOR WALLS ATTACHED w/ 8d NAILS SPACED 6" O.C. ALONG PANEL EDGES AND 12" O.C. IN THE FIELD.
 - GB REFERS TO "GYPSUM BOARD." CONTRACTOR IS TO INSTALL 1/2" (MIN.) GYPSUM BOARD ON BOTH SIDES OF WALL WHERE NOTED ON THE PLANS ATTACHED WITH 1 1/4" LONG #6 SCREWS OR 1 5/8" LONG 5d COOLER NAILS SPACED 7" O.C. ALONG PANEL EDGES AND IN THE FIELD.
 - BRACED WALL DESIGN APPLIED IN WIND ZONES UP TO 130 MPH. FOR HIGH WIND ZONES, BRACED WALLS ARE TO BE CONSTRUCTED IN ACCORDANCE WITH CHAPTER 45 OF THE NRC 2018 EDITION.
 - SEE NOTES AND DETAIL SHEETS FOR ADDITIONAL BRACED WALL INFORMATION.

- STRUCTURAL NOTES:**
- ALL FRAMING LUMBER TO BE #2 SPF OR #2 SYP (UNO).
 - ALL LOAD BEARING HEADERS TO BE (2) 2 x 6 (UNO).
 - WINDOW AND DOOR HEADERS TO BE SUPPORTED w/ (1) JACK STUD AND (1) KING STUD EA END (UNO). SEE TABLE R602.15 FOR ADDITIONAL KING STUD REQUIREMENTS.
 - SQUARES DENOTE POINT LOADS WHICH REQUIRE SOLID BLOCKING TO GIRDER OR FOUNDATION. SQUARES TO BE (2) STUDS (UNO).
 - REFER TO NOTES AND DETAIL SHEETS FOR ADDITIONAL STRUCTURAL INFORMATION.

LINTEL SCHEDULE FOR BRICK/NATURAL STONE SUPPORT

LENGTH (FT.)	SIZE OF LINTEL
UP TO 4 FT.	L 3 1/2 x 3 1/2 x 1/4
4-8	L 5 x 3 1/2 x 5/16 LLV
8 AND GREATER	L 6 x 4 x 5/16 LLV

- BRICK SUPPORT NOTES:**
- LINTEL SCHEDULE APPLIES TO ALL OPENINGS IN BRICK VENEER (UNO). SEE ARCH DIAGS. FOR SIZE AND LOCATION OF OPENINGS.
 - (LLV) = LONG LEG VERTICAL
 - LENGTH = CLEAR OPENING
 - EMBED ALL ANGLE IRONS MIN. 4" EACH SIDE INTO VENEER TO PROVIDE BEARING.
 - FOR ALL HEADERS 8'-0" AND GREATER IN LENGTH, ATTACH STEEL ANGLE TO HEADER w/ 1/2" LAG SCREWS @ 12" O.C. STAGGERED.
 - FOR ALL BRICK SUPPORT @ ROOF LINES, FASTEN (2) 2 x 10 BLOCKING BETWEEN STUDS w/ (4) 12d NAILS PER PLY. FASTEN A 6" x 4" x 5/16" STEEL ANGLE TO (2) 2 x 10 BLOCKING w/ (2) 1/2" LAG SCREWS @ 12" O.C. STAGGERED. SEE SECTION R103.B.21 OF THE 2018 NRC FOR ADDITIONAL BRICK SUPPORT INFORMATION.
 - PRECAST REINFORCED CONCRETE LINTELS ENGINEERED BY OTHERS MAY BE USED IN LIEU OF STEEL LINTELS.

LEGEND

CONT	CONTINUOUS
XT	EXTRA TRUSS
XJ	EXTRA JOIST
DJ	DOUBLE JOIST
TJ	TRIPLE JOIST
EA	EACH
()	NUMBER OF STUDS
DSP	DOUBLE STUD POCKET
TSP	TRIPLE STUD POCKET
OC	ON CENTER
SPF	SPRUCE PINE FIR
SYP	SOUTHERN YELLOW PINE
TRTD	PRESSURE TREATED
TYP	TYPICAL
UNO	UNLESS NOTED OTHERWISE

TABLE R602.7.5
MINIMUM NUMBER OF FULL HEIGHT KING STUDS AT EACH END OF HEADERS IN EXTERIOR WALLS

HEADER SPAN (FEET)	MINIMUM NUMBER OF FULL HEIGHT STUDS (KINGS)
UP TO 3'	1
> 3' TO 6'	2
> 6' TO 9'	3
> 9' TO 12'	4
> 12' TO 15'	5

DATE: OCTOBER 16, 2024
SCALE: 1/4" = 1'-0"
DRAWN BY: MAIN STREET DESIGN
ENGINEERED BY: ZHH

S-4b
ATTIC FLOOR
FRAMING PLAN

Wellers Knoll Lot 88

SCALE NOTE:
 LARGE FORMAT PRINTS ARE TO SCALE AS NOTED.
 11" x 17" PRINTS ARE ONE HALF THE NOTED SCALE

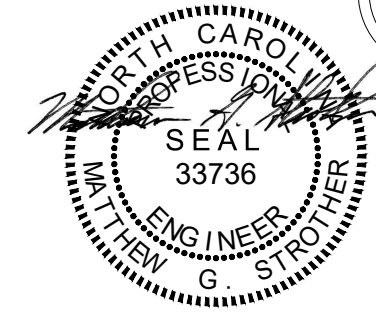

10/16/2024

J.S. THOMPSON
ENGINEERING, INC
 333 EAST SIX FORKS ROAD, SUITE 180, RALEIGH, NC 27609
 PHONE: (919) 7899919 FAX: (919) 7899921
 N.C. LICENSE NO.: C1733

WILLOW
 DAVIDSON HOMES

STRUCTURAL NOTES:

1. ALL FRAMING LUMBER TO BE #2 SPF OR #2 SYP (UNO).
2. STICK FRAME OVER-FRAMED ROOF SECTIONS W/ 2 x 8 RIDGES, 2 x 6 RAFTERS @ 16" O.C. AND FLAT 2 x 10 VALLEYS OR USE VALLEY TRUSSES.
3. FASTEN FLAT VALLEYS TO RAFTERS OR TRUSSES WITH SIMPSON H2.5A HURRICANE TIES @ 32" O.C. MAX. PASS HURRICANE TIES THROUGH NOTCH IN ROOF SHEATHING. EACH RAFTER IS TO BE FASTENED TO THE FLAT VALLEY WITH A MIN. OF (6) 12d TOE NAILS.
4. REFER TO SECTION R802.11 OF THE 2018 NRC FOR REQUIRED UPLIFT RESISTANCE AT RAFTERS AND TRUSSES.
5. REFER TO NOTES AND DETAIL SHEETS FOR ADDITIONAL STRUCTURAL INFORMATION.

BRICK SUPPORT NOTE:

1. FASTEN (2) 2 x 10 BLOCKING BETWEEN WALL STUDS W/ (4) 12d NAILS PER PLY. FASTEN A 6" x 4" x 5/16" STEEL ANGLE TO (2) 2 x 10 BLOCKING W/ (2) 1/2" LAG SCREWS @ 12" O.C. STAGGERED. SEE SECTION R103.8.21 OF THE 2018 NRC FOR ADDITIONAL BRICK SUPPORT INFORMATION.
2. WHERE ROOF SLOPES EXCEED 1:12, INSTALL 3" x 3" x 1/4" STEEL PLATE STOPS AT 24" O.C. PER SECTION R103.8.21 OF THE NORTH CAROLINA RESIDENTIAL CODE, 2018 EDITION.

LEGEND

XR	EXTRA RAFTER
XT	EXTRA TRUSS
DR	DOUBLE RAFTER
TR	TRIPLE RAFTER
RS	RAFTER SUPPORT
TS	TRUSS SUPPORT
CONT	CONTINUOUS
EA	EACH
OC	ON CENTER
SPF	SPRUCE PINE FIR
SYP	SOUTHERN YELLOW PINE
TYP	TYPICAL
UNO	UNLESS NOTED OTHERWISE

DATE: OCTOBER 16, 2024

SCALE: 1/4" = 1'-0"

DRAWN BY: MAIN STREET DESIGN

ENGINEERED BY: ZHH

S-5b
 ROOF FRAMING
 PLAN

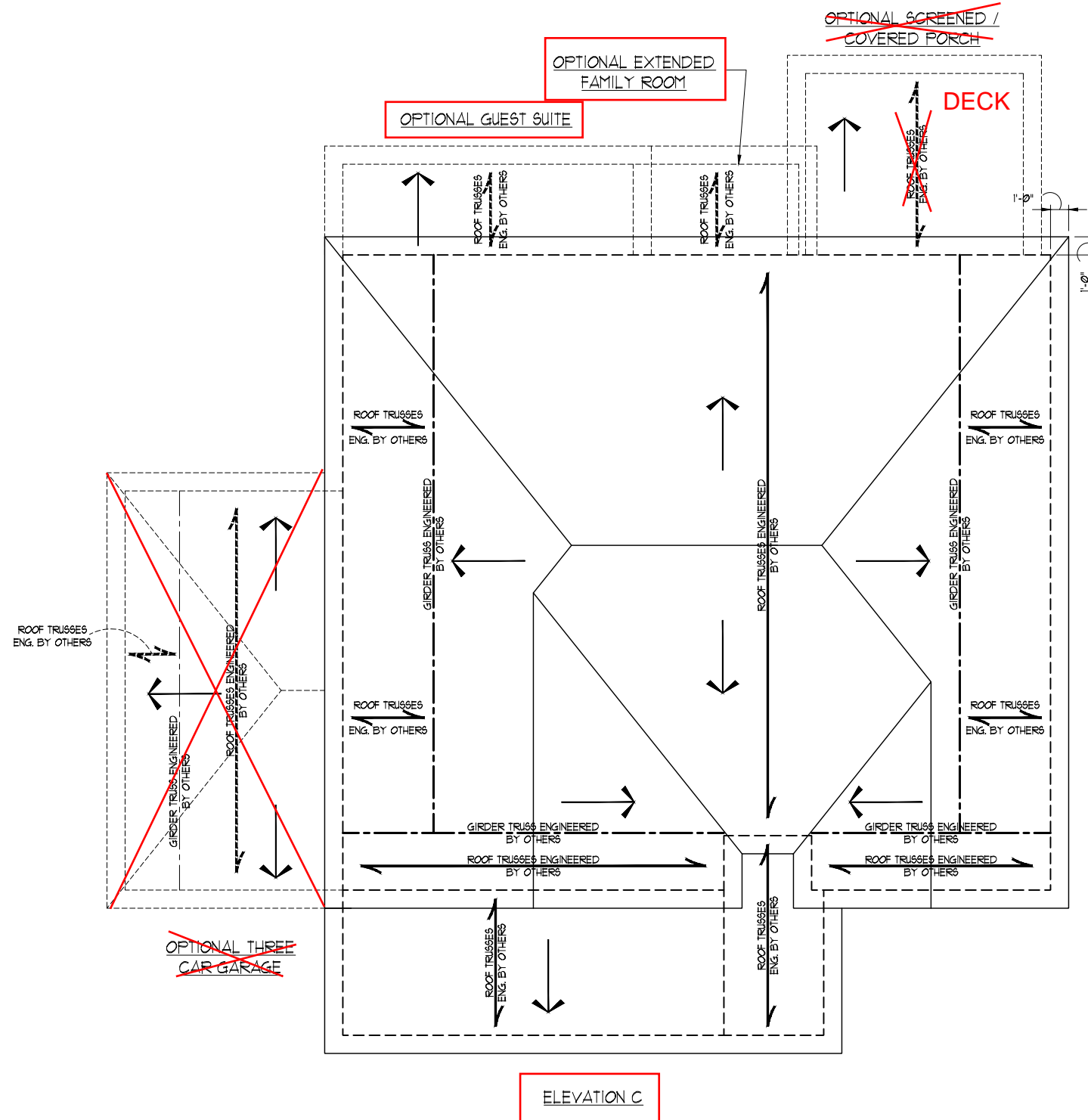

ELEVATION C

Wellers Knoll Lot 88

SCALE NOTE:
LARGE FORMAT PRINTS ARE TO SCALE AS NOTED.
11" x 17" PRINTS ARE ONE HALF THE NOTED SCALE

10" POURED BASEMENT WALL

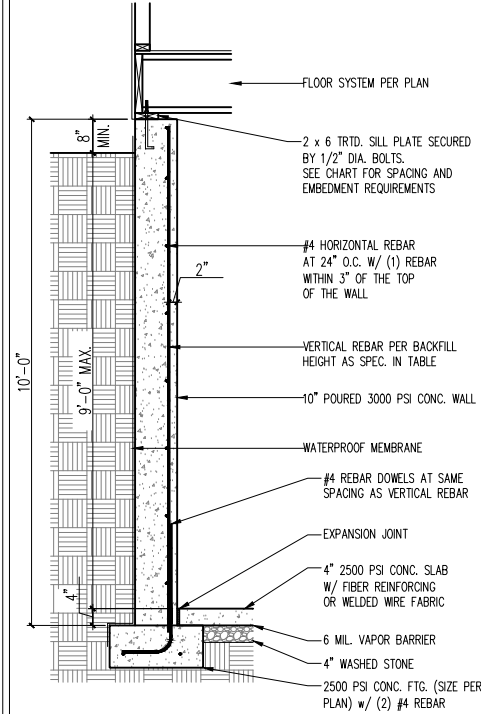

BACKFILL HEIGHT (FT)	VERTICAL REBAR
≤ 5	#4 @ 48" O.C.
6	#4 @ 32" O.C.
7	#4 @ 24" O.C. OR #5 @ 36" O.C. OR #6 @ 56" O.C.
8	#4 @ 20" O.C. OR #5 @ 32" O.C. OR #6 @ 48" O.C.
9	#4 @ 16" O.C. OR #5 @ 24" O.C. OR #6 @ 40" O.C.

BASEMENT WALL REINFORCEMENT TABLE

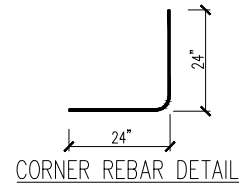

CORNER REBAR DETAIL

WHERE FRAMED WALLS WILL BE SUPPORTED PARTIALLY BY THE BRICK WYTHE, STANDARD CORRUGATED WALL TIES ARE TO BE FASTENED TO THE POURED WALLS w/ 1 1/4" LONG CONCRETE SCREWS OR 1 1/16" POWDER DRIVEN FASTENERS @ 16" O.C. HORIZONTALLY AND VERTICALLY. WALL TIES ARE TO BE LOCATED A MIN. OF 8" FROM THE TOP OF THE WALL AND ARE FULLY EMBEDDED INTO THE HEAD AND BED JOINTS. ALL FASTENERS ARE TO BE INSTALLED PER THE MANUFACTURERS SPECS.

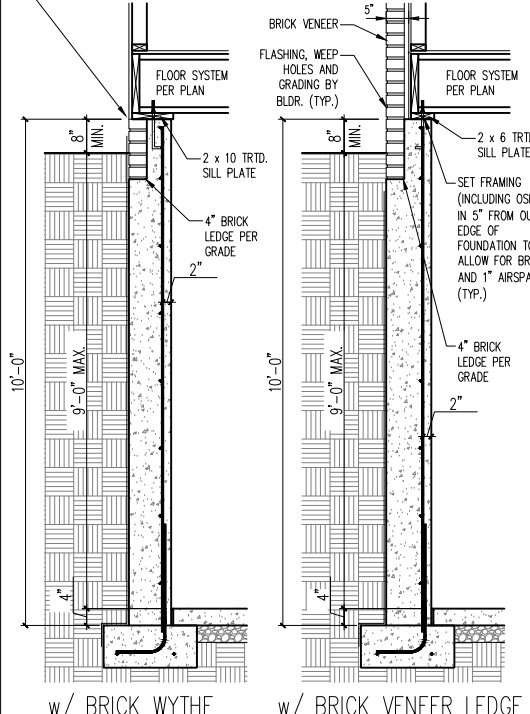

8" POURED BASEMENT WALL

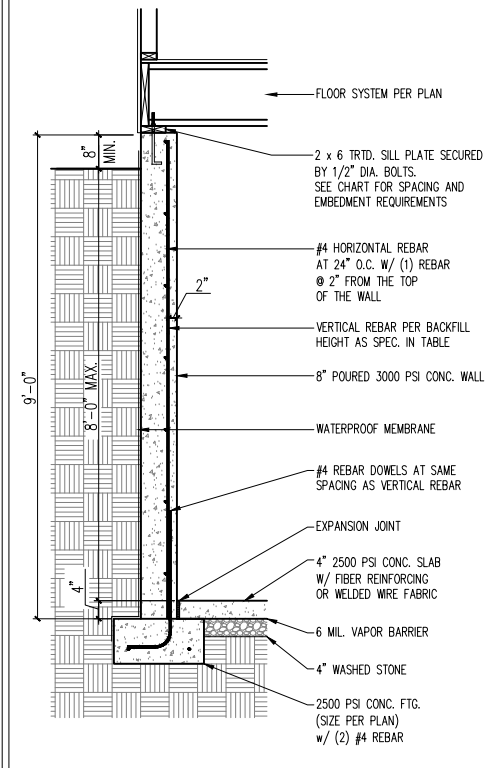

BACKFILL HEIGHT (FT)	VERTICAL REBAR
≤ 5	#4 @ 48" O.C.
6	#4 @ 24" O.C. OR #5 @ 36" O.C.
7	#4 @ 16" O.C. OR #5 @ 24" O.C. OR
8	#4 @ 12" O.C. OR #5 @ 18" O.C. OR #6 @ 28" O.C. OR

BASEMENT WALL REINFORCEMENT TABLE

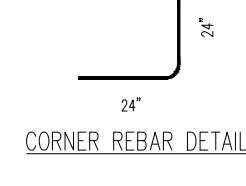

CORNER REBAR DETAIL

ANCHOR SPACING AND EMBEDMENT

WIND ZONE	120 MPH	130 MPH
SPACING	6'-0" O.C. INSTALL MIN. (2) ANCHORS PER PLATE SECTION AND (1) ANCHOR WITHIN 12" OF CORNERS	4'-0" O.C. INSTALL MIN. (2) ANCHORS PER PLATE SECTION AND (1) ANCHOR WITHIN 12" OF CORNERS
EMBEDMENT	7"	15" INTO MASONRY 7" INTO CONCRETE

NOTE:
THREADED ROD WITH EPOXY, SIMPSON TITEN HD, OR APPROVED ANCHORS SPACED AS REQUIRED TO PROVIDE EQUIVALENT ANCHORAGE TO 1/2" DIAMETER ANCHOR BOLTS MAY BE USED IN LIEU OF 1/2" ANCHOR BOLTS.

IMPORTANT NOTE:

FOUNDATIONS AS DENOTED IN THESE DETAILS ARE NOT SUITABLE FOR SUPPORT OF ADDITIONAL SURCHARGE LOADING FROM ADJACENT STRUCTURES OR DRIVEWAYS. FOUNDATIONS WITH EXTRA LATERAL LOADING IN THESE SCENARIOS WILL REQUIRE LOT SPECIFIC DESIGN ON A CASE BY CASE BASIS. CONSULT THE ENGINEER OF RECORD WHEN PLANNING TO BUILD IN CLOSE PROXIMITY TO THE FOUNDATION AS WE WILL NOT BE HELD LIABLE FOR FOUNDATION FAILURE. SEE R403.1.9 OF THE 2018 NCRS FOR ADDITIONAL INFORMATION.

STRUCTURAL NOTES:

- FOR #4 REBAR, 24" MINIMUM REBAR LAP SPLICE LENGTH. FOR #5 REBAR, 32" MINIMUM REBAR LAP SPLICE LENGTH. FOR #6 REBAR, 38" MINIMUM REBAR LAP SPLICE LENGTH.
- REBAR TO MAINTAIN A MINIMUM CONCRETE COVER OF 3" (UNO).
- REBAR TO BE ASTM A615 GRADE 60.
- SOIL BEARING CAPACITY IS REQUIRED TO BE 2000 PSF MIN.
- INSTALL #4 L-BARS AT ALL WALL CORNERS AT SAME SPACING AS HORIZ. STEEL. SEE DETAIL.
- THE FLOOR FRAMING IS TO BE INSTALLED AND A MIN. OF SEVEN DAYS IS REQUIRED TO ALLOW THE CONCRETE TO CURE BEFORE THE BACKFILL CAN BE INSTALLED. THE BACKFILL IS RECOMMENDED TO BE PLACED IN 12" LIFTS AND CAREFULLY TAMPED.
- A 4" LEDGE IS TO BE PROVIDED FOR THE PORCH SLAB. THE WALLS ARE REQUIRED TO BE BONDED TO THE SLABS USING #4 x 36" REBAR DOWELS 32" O.C. EMBEDDED 4" INTO THE CONC. USING EPOXY.
- WHERE THE FLOOR JOISTS ARE PARALLEL TO THE WALLS, 2 x 4 BLOCKING IS TO BE INSTALLED 24" O.C. BETWEEN THE BOTTOM FLANGES OF THE I-JOISTS FOR A MIN. OF 6'-0" AWAY FROM THE WALL OR DIAGONAL 2 x 6 BLOCKS MAY BE INSTALLED 24" O.C. FROM THE EDGE OF THE SILL PLATE TO THE TOP FLANGE AND SUBFLOORING, ATTACHED w/ (3) 12d NAILS EACH END.

NOTE TO FOUNDATION CONTRACTOR:

ALTERNATE REINFORCED CONCRETE POURED WALL DESIGNS ENGINEERED BY OTHERS MAY BE CONSTRUCTED. NO CONTINUOUS FOOTINGS OR LUG FOOTINGS MAY BE REDUCED IN SIZE.

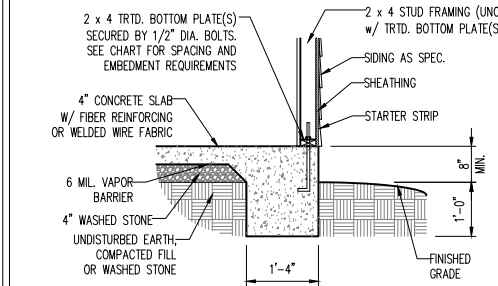

TYPICAL SLAB

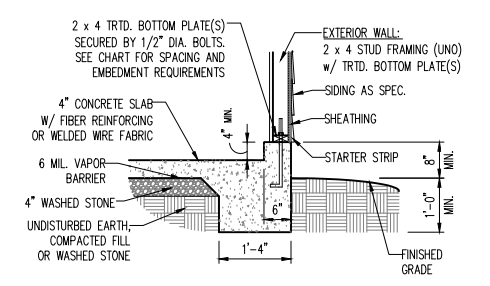

GARAGE CURB

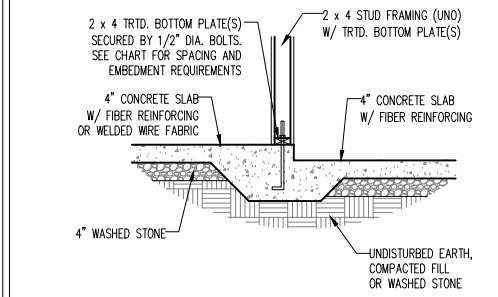

STEP IN GARAGE

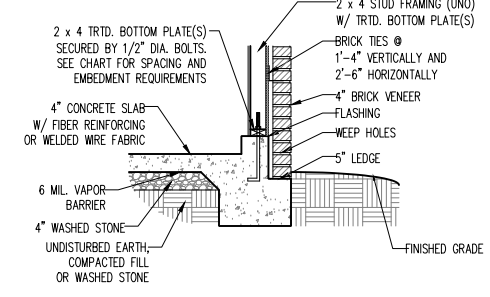

GARAGE CURB w/ BRICK LEDGE

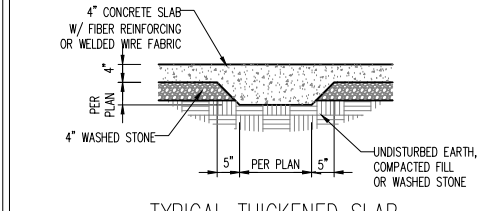

TYPICAL THICKENED SLAB

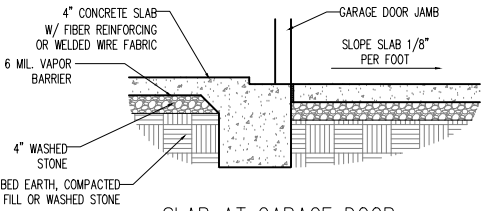

SLAB AT GARAGE DOOR

J.S. THOMPSON ENGINEERING, INC.
333 EAST SIX FORKS ROAD, SUITE 180, RALEIGH, NC 27609
PHONE: (919) 7899919 FAX: (919) 7899921
N.C. LICENSE NO.: C1713

WILLOW HOMES
DAVIDSON HOMES

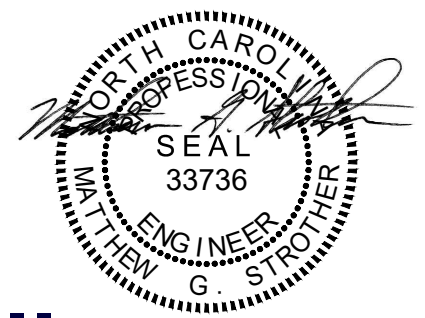

10/16/2024

**Wellers Knoll
Lot 88**

This sealed page is to be used in conjunction with a full plan set engineered by J.S. Thompson Engineering, Inc. only. Use of this individual sealed page within architectural pages or shop drawings by others is a punishable offense under N.C. Statute § 89C-23

DATE: OCTOBER 16, 2024
SCALE: 1/4" = 1'-0"
DRAWN BY: MAIN STREET DESIGN
ENGINEERED BY: ZHH

D4
WALL BRACING
NOTES AND DETAILS

GENERAL NOTES

- ENGINEER'S SEAL APPLIES ONLY TO STRUCTURAL COMPONENTS INCLUDING ROOF RAFTERS, HIPPS, VALLEYS, RIDGES, FLOORS, WALLS, BEAMS, HEADERS, COLUMNS, CANTILEVERS, OFFSET LOAD BEARING WALLS, PIERS, GIRDER SYSTEM AND FOOTING. ENGINEER'S SEAL DOES NOT CERTIFY DIMENSIONAL ACCURACY OF ARCHITECTURAL LAYOUT INCLUDING ROOF. ENGINEER'S SEAL DOES NOT APPLY TO I-JOIST OR FLOOR/ROOF TRUSS LAYOUT DESIGN AND ACCURACY.
- ALL CONSTRUCTION SHALL CONFORM TO THE LATEST REQUIREMENTS OF THE NORTH CAROLINA RESIDENTIAL CODE (NRC), 2018 EDITION, PLUS ALL LOCAL CODES AND REGULATIONS. THE STRUCTURAL ENGINEER IS NOT RESPONSIBLE FOR, AND WILL NOT HAVE CONTROL OF, CONSTRUCTION MEANS, METHODS, TECHNIQUES, SEQUENCES OR PROCEDURES, OR SAFETY PRECAUTIONS AND PROGRAMS IN CONNECTION WITH THE CONSTRUCTION WORK. NOR WILL THE ENGINEER BE RESPONSIBLE FOR THE CONTRACTORS FAILURE TO CARRY OUT THE CONSTRUCTION WORK IN ACCORDANCE WITH THE CONTRACT DOCUMENTS.
- STRUCTURAL DESIGN BASED ON THE PROVISIONS OF THE NRC, 2018 EDITION (R301.4 – R301.7)

DESIGN CRITERIA:	LIVE LOAD (PSF)	DEAD LOAD (PSF)	DEFLECTION (IN)
ATTIC WITH LIMITED STORAGE	20	10	L/240 (L/360 w/ BRITTLE FINISHES)
ATTIC WITHOUT STORAGE	10	10	L/360
DECKS	40	10	L/360
EXTERIOR BALCONIES	40	10	L/360
FIRE ESCAPES	40	10	L/360
HANDRAILS/GUARDRAILS	200 LB OR 50 (PLF)	10	L/360
PASSENGER VEHICLE GARAGE	50	10	L/360
ROOMS OTHER THAN SLEEPING ROOM	40	10	L/360
SLEEPING ROOMS	30	10	L/360
STAIRS	40	10	L/360
WIND LOAD	(BASED ON TABLE R301.2(4) WIND ZONE AND EXPOSURE)		
GROUND SNOW LOAD: P _g	20 (PSF)		

- I-JOIST SYSTEMS DESIGNED WITH 12 PSF DEAD LOAD AND DEFLECTION (IN) OF L/480
- FLOOR TRUSS SYSTEMS DESIGNED WITH 15 PSF DEAD LOAD

- FOR 115 AND 120 MPH WIND ZONES, FOUNDATION ANCHORAGE IS TO COMPLY WITH SECTION R403.1.6 OF THE NRC, 2018 EDITION. FOR 130 MPH, 140 MPH, AND 150 MPH WIND ZONES, FOUNDATION ANCHORAGE IS TO COMPLY WITH SECTION 4504 OF THE NRC, 2018 EDITION.
- ENERGY EFFICIENCY COMPLIANCE AND INSULATION VALUES OF THE BUILDING TO BE IN ACCORDANCE WITH CHAPTER 11 OF THE NRC, 2018 EDITION.

FOOTING AND FOUNDATION NOTES

- FOUNDATION DESIGN BASED ON A MINIMUM ALLOWABLE BEARING CAPACITY OF 2000 PSF. CONTACT GEOTECHNICAL ENGINEER IF BEARING CAPACITY IS NOT ACHIEVED.
- FOR ALL CONCRETE SLABS AND FOOTINGS, THE AREA WITHIN THE PERIMETER OF THE BUILDING ENVELOPE SHALL HAVE ALL VEGETATION, TOP SOIL AND FOREIGN MATERIAL REMOVED. FILL MATERIAL SHALL BE FREE OF VEGETATION AND FOREIGN MATERIAL. THE FILL SHALL BE COMPACTED TO ASSURE UNIFORM SUPPORT OF THE SLAB, AND EXCEPT WHERE APPROVED, THE FILL DEPTHS SHALL NOT EXCEED 24" FOR CLEAN SAND OR GRAVEL. A 4" THICK BASED COURSE CONSISTING OF CLEAN GRADED SAND OR GRAVEL SHALL BE PLACED. A BASE COURSE IS NOT REQUIRED WHERE A CONCRETE SLAB IS INSTALLED ON WELL-DRAINED OR SAND-GRAVEL MIXTURE SOILS CLASSIFIED AS GROUP 1, ACCORDING TO THE UNITED SOIL CLASSIFICATION SYSTEM IN ACCORDANCE WITH TABLE R405.1 OF THE NRC, 2018 EDITION.
- PROPERLY DEWATER EXCAVATION PRIOR TO POURING CONCRETE WHEN BOTTOM OF CONCRETE SLAB IS AT OR BELOW WATER TABLE. IF APPLICABLE, 3/4" - 1" DEEP CONTROL JOINTS ARE TO BE SAWED WITHIN 4 TO 12 HOURS OF CONCRETE FINISHING AND WALL LOCATIONS HAVE BEEN MARKED. ADJUST WHERE NECESSARY.
- CONCRETE SHALL CONFORM TO SECTION R402.2 OF THE NRC, 2018 EDITION. CONCRETE REINFORCING STEEL TO BE ASTM A615 GRADE 60. WELDED WIRE FABRIC TO BE ASTM A185. MAINTAIN A MINIMUM CONCRETE COVER AROUND REINFORCING STEEL OF 3" IN FOOTINGS AND 1 1/2" IN SLABS. FOR POURED CONCRETE WALLS, CONCRETE COVER FOR REINFORCING STEEL MEASURED FROM THE INSIDE FACE OF THE WALL SHALL NOT BE LESS THAN 3/4". CONCRETE COVER FOR REINFORCING STEEL MEASURED FROM THE OUTSIDE FACE OF THE WALL SHALL NOT BE LESS THAN 1 1/2" FOR #5 BARS OR SMALLER, AND NOT LESS THAN 2" FOR #6 BARS OR LARGER.
- MASONRY UNITS TO CONFORM TO ACE 530/ASCE 5/TMS 402. MORTAR SHALL CONFORM TO ASTM C270.
- THE UNSUPPORTED HEIGHT OF MASONRY PIERS SHALL NOT EXCEED FOUR TIMES THEIR LEAST DIMENSION FOR UNFILLED HOLLOW CONCRETE MASONRY UNITS AND TEN TIMES THEIR LEAST DIMENSION FOR SOLID OR SOLID FILLED PIERS. PERS MAY BE FILLED SOLID WITH CONCRETE OR TYPE M OR S MORTAR. PIERS AND WALLS SHALL BE CAPPED WITH 8" OF SOLID MASONRY.
- THE CENTER OF EACH OF THE PIERS SHALL BEAR IN THE MIDDLE THIRD OF ITS RESPECTIVE FOOTING. EACH GIRDER SHALL BEAR IN THE MIDDLE THIRD OF THE PIERS.
- ALL CONCRETE AND MASONRY FOUNDATION WALLS ARE TO BE CONSTRUCTED IN ACCORDANCE WITH THE PROVISIONS OF SECTION R404 OF THE NRC, 2018 EDITION OR IN ACCORDANCE WITH ACI 318, ACI 332, NCMA TR68-A OR ACE 530/ASCE 5/TMS 402. MASONRY FOUNDATION WALLS ARE TO BE REINFORCED PER TABLE R404.1.1(1), R404.1.1(2), R404.1.1(3), OR R404.1.1(4) OF THE NRC, 2018 EDITION. CONCRETE FOUNDATION WALLS ARE TO BE REINFORCED PER TABLE R404.1.1(5) OF THE NRC, 2018 EDITION. STEP CONCRETE FOUNDATION WALLS TO 2 x 6 FRAMED WALLS AT 16" O.C. WHERE GRADE PERMITS (UNO).

FRAMING NOTES

- ALL FRAMING LUMBER SHALL BE #2 SPF MINIMUM (F_b = 875 PSI, F_v = 375 PSI, E = 1600000 PSI) UNLESS NOTED OTHERWISE (UNO). ALL TREATED LUMBER SHALL BE #2 SYP MINIMUM (F_b = 975 PSI, F_v = 175 PSI, E = 1600000 PSI) UNLESS NOTED OTHERWISE (UNO).
- LAMINATED VENEER LUMBER (LVL) SHALL HAVE THE FOLLOWING MINIMUM PROPERTIES: F_b = 2600 PSI, F_v = 285 PSI, E = 1900000 PSI. LAMINATED STRAND LUMBER (LSL) SHALL HAVE THE FOLLOWING MINIMUM PROPERTIES: F_b = 2325 PSI, F_v = 310 PSI, E = 1550000 PSI. PARALLEL STRAND LUMBER (PSL) UP TO 7" DEPTH SHALL HAVE THE FOLLOWING MINIMUM PROPERTIES: F_c = 2500 PSI, E = 1800000 PSI. PARALLEL STRAND LUMBER (PSL) MORE THAN 7" DEPTH SHALL HAVE THE FOLLOWING MINIMUM PROPERTIES: F_c = 2900 PSI, E = 2000000 PSI. INSTALL ALL CONNECTIONS PER MANUFACTURER'S SPECIFICATIONS.
- STRUCTURAL STEEL SHALL CONFORM TO THE FOLLOWING ASTM SPECIFICATIONS

A. W AND WT SHAPES:	ASTM A992
B. CHANNELS AND ANGLES:	ASTM A36
C. PLATES AND BARS:	ASTM A36
D. HOLLOW STRUCTURAL SECTIONS:	ASTM A500 GRADE B
E. STEEL PIPE:	ASTM A53, GRADE B, TYPE E OR S

STEEL BEAMS SHALL BE SUPPORTED AT EACH END WITH A MINIMUM BEARING LENGTH OF 3 1/2" AND FULL FLANGE WIDTH (UNO). PROVIDE SOLID BEARING FROM BEAM SUPPORT TO FOUNDATION. BEAMS SHALL BE ATTACHED AT THE BOTTOM FLANGE TO EACH SUPPORT AS FOLLOWS (UNO):

- | | |
|----------------------------|--|
| A. WOOD FRAMING | (2) 1/2" DIA. x 4" LONG LAG SCREWS |
| B. CONCRETE | (2) 1/2" DIA. x 4" WEDGE ANCHORS |
| C. MASONRY (FULLY GROUTED) | (2) 1/2" DIA. x 4" LONG SIMPSON TITEN HD ANCHORS |

LATERAL SUPPORT IS CONSIDERED ADEQUATE PROVIDING THE JOISTS ARE TOE NAILED TO THE 2x NAILER ON TOP OF THE STEEL BEAM, AND THE 2x NAILER IS SECURED TO THE TOP OF THE STEEL BEAM w/ (2) ROWS OF SELF TAPPING SCREWS @ 16" O.C. OR (2) ROWS OF 1/2" DIAMETER BOLTS @ 16" O.C. IF 1/2" BOLTS ARE USED TO FASTEN THE NAILER, THE STEEL BEAM SHALL BE FABRICATED w/ (2) ROWS OF 9/16" DIAMETER HOLES @ 16" O.C.

- SQUARES DENOTE POINT LOADS WHICH REQUIRE SOLID BLOCKING TO GIRDER OR FOUNDATION. SHADED SQUARES DENOTE POINT LOADS FROM ABOVE WHICH REQUIRE SOLID BLOCKING TO SUPPORTING MEMBER BELOW.
- ALL LOAD BEARING HEADERS TO CONFORM TO TABLE R602.7(1) AND R602.7(2) OF THE NRC, 2018 EDITION OR BE (2) 2 x 6 WITH (1) JACK AND (1) KING STUD EACH END (UNO), WHICHEVER IS GREATER ALL HEADERS TO BE SECURED TO EACH JACK STUD WITH (4) 8d NAILS. ALL BEAMS TO BE SUPPORTED WITH (2) STUDS AT EACH BEARING POINT (UNO). INSTALL KING STUDS PER SECTION R602.7.5 OF THE NORTH CAROLINA RESIDENTIAL CODE, 2018 EDITION.
- ALL BEAMS, HEADERS, OR GIRDER TRUSSES PARALLEL TO WALL ARE TO BEAR FULLY ON (1) JACK OR (2) STUDS MINIMUM OR THE NUMBER OF JACKS OR STUDS NOTED. ALL BEAMS OR GIRDER TRUSSES PERPENDICULAR TO WALL AND SUPPORTED BY (3) STUDS OR LESS ARE TO HAVE 1 1/2" MINIMUM BEARING (UNO). ALL BEAMS OR GIRDER TRUSSES PERPENDICULAR TO WALL AND SUPPORTED BY MORE THAN (3) STUDS OR OTHER NOTED COLUMN ARE TO BEAR FULLY ON SUPPORT COLUMN FOR ENTIRE WALL DEPTH (UNO). BEAM ENDS THAT BUTT INTO ONE ANOTHER ARE TO EACH BEAR EQUAL LENGTHS (UNO).
- FLITCH BEAMS SHALL BE BOLTED TOGETHER USING 1/2" DIAMETER BOLTS (ASTM A307) WITH WASHERS PLACED AT THREADED END OF BOLT. BOLTS SHALL BE SPACED AT 24" CENTERS (MAXIMUM), AND STAGGERED AT TOP AND BOTTOM OF BEAM (2" EDGE DISTANCE), WITH (2) BOLTS LOCATED AT 6" FROM EACH END (UNO).
- ALL I-JOIST OR TRUSS LAYOUTS ARE TO BE IN COMPLIANCE WITH THE OVERALL DESIGN SPECIFIED ON THE PLANS. ALL DEVIATIONS ARE TO BE BROUGHT TO THE ATTENTION OF THE ENGINEER OF RECORD PRIOR TO INSTALLATION.
- BRACED WALL PANELS SHALL BE CONSTRUCTED ACCORDING TO THE NORTH CAROLINA RESIDENTIAL CODE 2018 EDITION WALL BRACING CRITERIA. THE AMOUNT, LENGTH, AND LOCATION OF BRACING SHALL COMPLY WITH ALL APPLICABLE TABLES IN SECTION R602.10.
- PROVIDE DOUBLE JOIST UNDER ALL WALLS PARALLEL TO FLOOR JOISTS. PROVIDE SUPPORT UNDER ALL WALLS PARALLEL TO FLOOR TRUSSES OR I-JOISTS PER MANUFACTURER'S SPECIFICATIONS. INSTALL BLOCKING BETWEEN JOISTS OR TRUSSES FOR POINT LOAD SUPPORT FOR ALL POINT LOADS ALONG OFFSET LOAD LINES.
- FOR ALL HEADERS SUPPORTING BRICK VENEER THAT ARE LESS THAN 8'-0" IN LENGTH, REST A 6" x 4" x 5/16" STEEL ANGLE WITH 6" MINIMUM EMBEDMENT AT SIDES FOR BRICK SUPPORT (U.N.O). FOR ALL HEADERS 8'-0" AND GREATER IN LENGTH, BOLT A 6" x 4" x 5/16" STEEL ANGLE TO HEADER WITH 1/2" LAG SCREWS AT 12" O.C. STAGGERED FOR BRICK SUPPORT. FOR ALL BRICK SUPPORT AT ROOF LINES, BOLT A 6" x 4" x 5/16" STEEL ANGLE TO (2) 2 x 10 BLOCKING INSTALLED w/ (4) 12d NAILS EA. PLY BETWEEN WALL STUDS WITH (2) ROWS OF 1/2" LAG SCREWS AT 12" O.C. STAGGERED AND IN ACCORDANCE WITH SECTION R703.8.2.1 OF THE NRC, 2018 EDITION.
- FOR STICK FRAMED ROOFS: CIRCLES DENOTE (3) 2 x 4 POSTS FOR ROOF MEMBER SUPPORT. HIP SPLICES ARE TO BE SPACED A MINIMUM OF 8'-0". FASTEN MEMBERS WITH THREE ROWS OF 12d NAILS AT 16" O.C. FRAME DORMER WALLS ON TOP OF DOUBLE OR TRIPLE RAFTERS AS SHOWN (UNO).
- FOR TRUSSED ROOFS: FRAME DORMER WALLS ON TOP OF 2 x 4 LADDER FRAMING AT 24" O.C. BETWEEN ADJACENT ROOF TRUSSES. STICK FRAME OVER-FRAMED ROOF SECTIONS WITH 2 x 8 RIDGES, 2 x 6 RAFTERS AT 16" O.C. AND FLAT 2 x 10 VALLEYS (UNO).
- ALL 4 x 4 AND 6 x 6 POSTS TO BE INSTALLED WITH 700 LB CAPACITY UPLIFT CONNECTORS TOP AND BOTTOM (UNO.) POSTS MAY BE SECURED USING ONE SIMPSON H6 OR LTS12 UPLIFT CONNECTOR FASTENED TO THE BAND AT THE BOTTOM AND THE BEAM AT THE TOP OF EACH POST. ONE 16" SECTION OF SIMPSON CS16 COIL STRAPPING WITH (8) 8d HDG NAILS AT EACH END MAY BE USED IN LIEU OF EACH TWIST STRAP IF DESIRED. FOR MASONRY OR CONCRETE FOUNDATION USE SIMPSON POST BASE.

SCALE NOTE:
LARGE FORMAT PRINTS ARE TO SCALE AS NOTED.
11" x 17" PRINTS ARE ONE HALF THE NOTED SCALE

**J.S. THOMPSON
ENGINEERING, INC**
333 EAST SIX FORKS ROAD, SUITE 180 RALEIGH, NC 27609
PHONE: (919) 7899919 FAX: (919) 7899921
N.C. LICENSE NO.: C1733

WILLOW
DAVIDSON HOMES

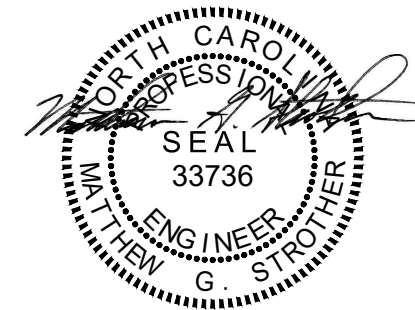

10/16/2024

This sealed page is to be used in conjunction with a full plan set engineered by J.S. Thompson Engineering, Inc. only. Use of this individual sealed page within architectural pages or shop drawings by others is a punishable offense under N.C. Statute § 89C-23

DATE: OCTOBER 16, 2024
SCALE: 1/4" = 1'-0"
DRAWN BY: MAIN STREET DESIGN
ENGINEERED BY: ZHH

D-5
STANDARD
STRUCTURAL NOTES

Wellers Knoll Lot 88

Summaries of limited excerpts of the Code, ANSI/TPI1-2014, and BCSI, and associated commentary, are provided within the truss submittal package in the Builders First Source Component Truss Responsibility and Liability Disclosure. These critical excerpts include, among other elements, critical safety information as well as specific Scope-of-Work assignments (and limitations of the same) for the Owner, Contractor, Building Designer, Truss Designer, and Truss Manufacturer. It is essential that ALL parties to the design and use of the Trusses review and become familiar with the information provided in the Builders First Source Component Truss Responsibility and Liability Disclosure, as well as the referenced sources, prior to performing work on the associated project.

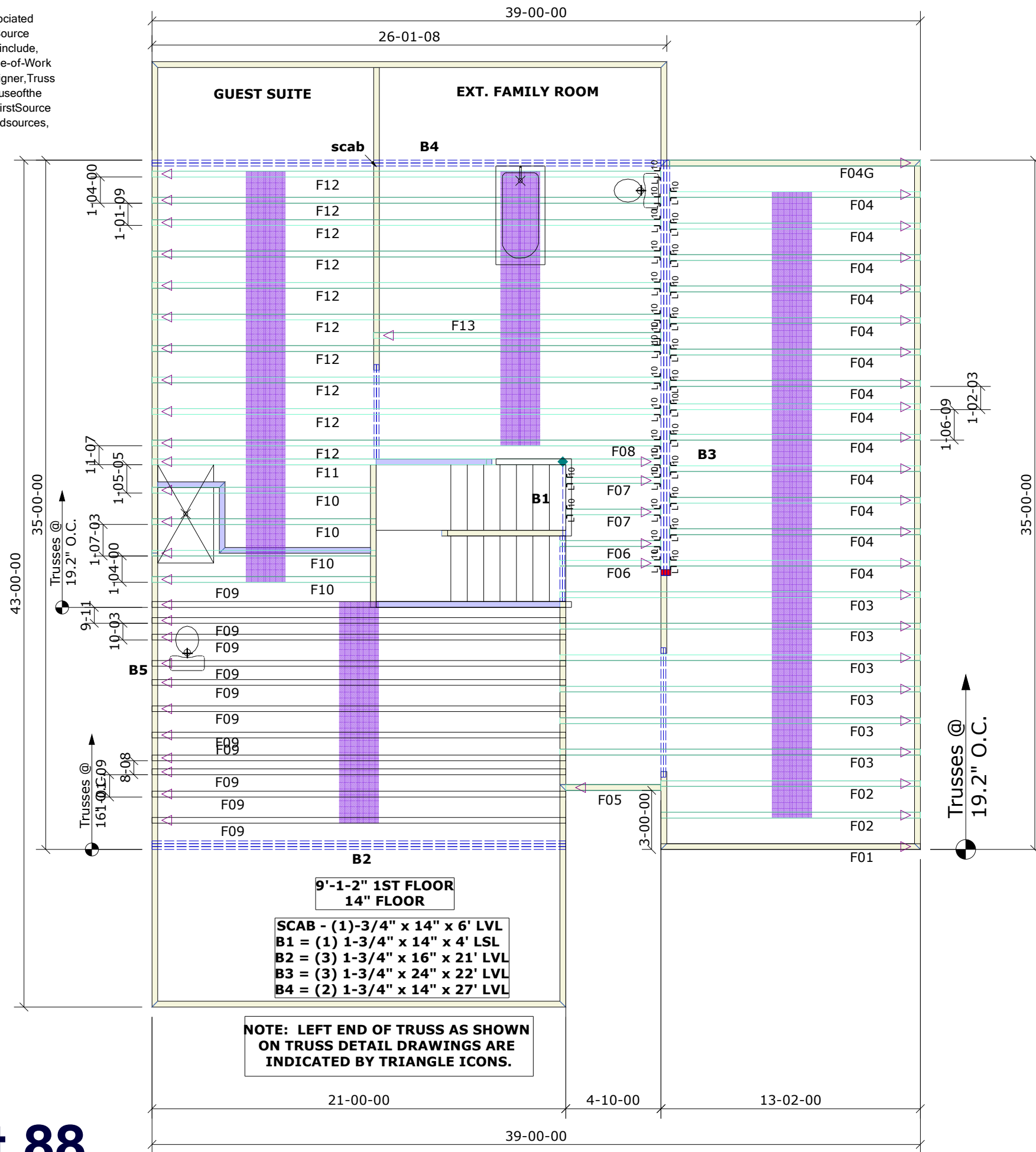

Builders First Source
 23 RED CEDAR WAY
 APEX, NC 27523
 Phone: (919) 363-4956
 Fax: (919) 387-8565
 http://www.bldr.com

General Notes:
 - Per ANSI/TPI 1-2002 all "Truss to Wall" connections are the responsibility of the Building Designer, not the Truss Manufacturer.

- Dimensions are Feet-Inches- Sixteenths.
- Trusses are to be 24" o.c. unless noted otherwise (U.N.O.)
- Trusses are not designed to support brick U.N.O.
- Do not cut or modify trusses without first contacting Builders First Source.
- Immediately contact Builders First Source if trusses are damaged.

Connection Notes:
 - All hangers are to be Simpson or equivalent U.N.O.
 - Use Manufacturer's specifications for all hanger connections U.N.O.
 - Use 10d x 1 1/2" Nails in hanger connections to single ply roof girder trusses.

Floor Notes:
 - Shift truss as required to avoid plumbing traps.
 - Installation Contractor and/or Field Supervisor are to verify all dimensions, trap locations, and options prior to installation

Dimension Notes:
 - Drawing not to scale. Do not scale dimensions

Hanger List		All Tie Downs H2.5A Unless noted	
32	LU5410	J L	Special Items List
Misc Material			
DAVIDSON			
WILLOW	Elev:	C	
WELLER'S KNOLL			
HARNETT	NC	Lot:	88
Appwright #			
4440436			
Code: IRC 2015			
Loading:			
T.C.L.L. 40			
T.C.D.L. 10			
B.C.L.L. 0			
B.C.D.L. 5			
Designed By: TG		Wind:	
Layout: WK88		M.P.H. -	
L/O Date: 2/3/25		Exposure Category	
		EXPOSURE B	
Pick Ticket: -		Job No.: WK88	
Sales No.: -		Acct No.: -	

Hatch Legend	
	Attic Room
	Volume Ceiling
	Stick Framing



Wellers Knoll Lot 88

Wellers Knoll Lot 88

Summations of limited excerpts of the Code, ANSI/TPI-2014, and BCSI, and associated commentary, are provided within the truss submittal package in the Builders First Source Component Truss Responsibility and Liability Disclosure. These critical excerpts include, among other elements, critical safety information as well as specific Scope-of-Work assignments (and limitations of the same) for the Owner, Contractor, Building Designer, Truss Designer, and Truss Manufacturer. It is essential that ALL parties to the design and use of the Trusses review and become familiar with the information provided in the Builders First Source Component Truss Responsibility and Liability Disclosure, as well as the referenced sources, prior to performing work on the associated project.

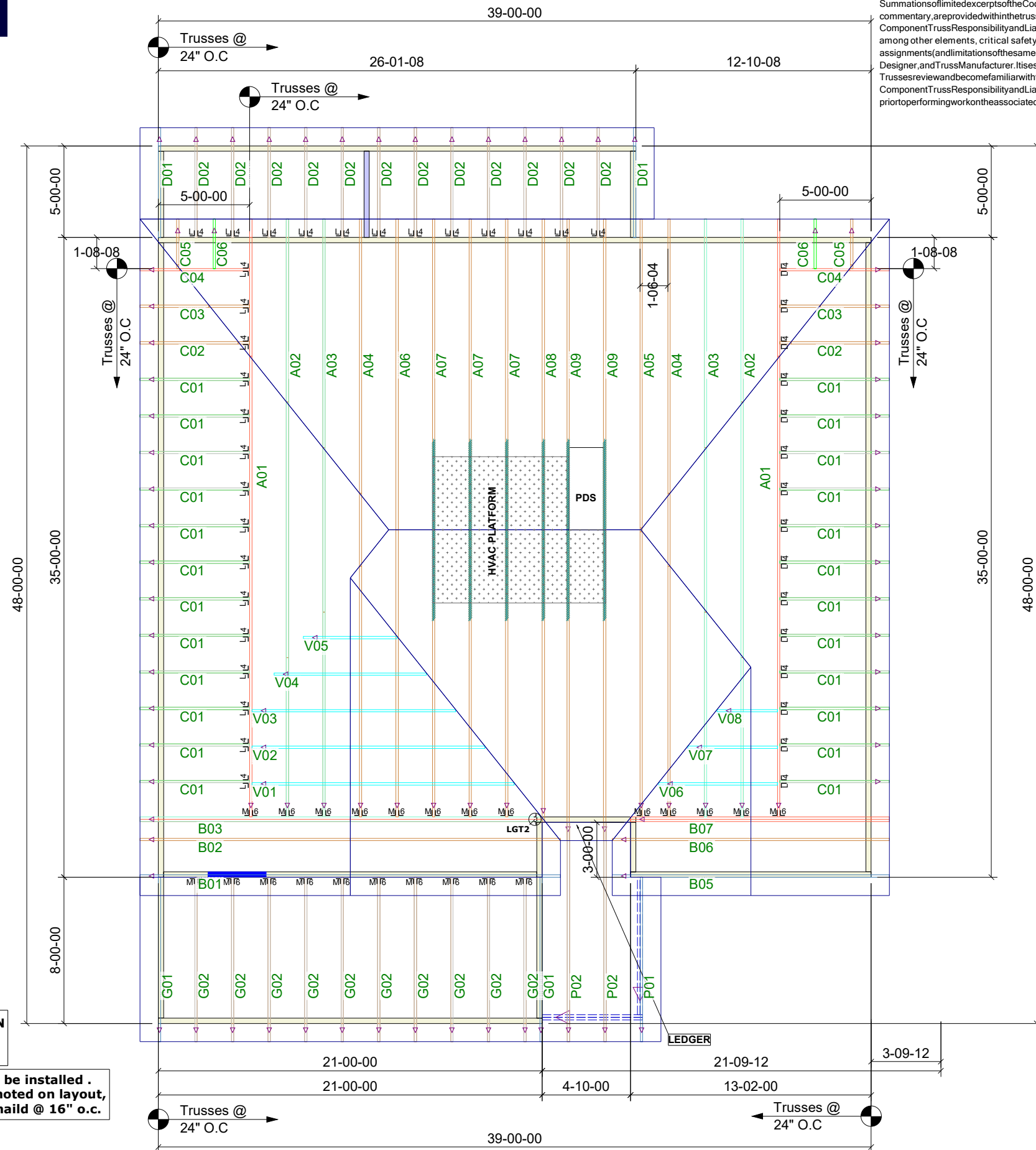

9'-1-2" 1ST FLOOR
14" FLOOR
8'-1-2" 2ND FLOOR

NOTE: LEFT END OF TRUSS AS SHOWN ON TRUSS DETAIL DRAWINGS ARE INDICATED BY TRIANGLE ICONS.

Space trusses 2' o.c. unless a wide P.D.S is going to be installed. If wide P.D.S. is used, follow special truss spacing as noted on layout, & attach 2x4 ledgers to Top & Bottom chords w/12d nail @ 16" o.c.



Builders First Source
23 Red Cedar Way
Apex, NC 27523
Phone: (919) 363-4956
Fax: (919) 387-8565
<https://www.bldr.com>

- General Notes:**
- Per ANSI/TPI 1-2002 all "Truss to Wall" connections are the responsibility of the Building Designer, not the Truss Manufacturer.
 - Dimensions are Feet-Inches-Sixteenths.
 - Trusses are to be 24" o.c. unless noted otherwise (U.N.O.)
 - Trusses are not designed to support brick U.N.O.
 - Do not cut or modify trusses without first contacting Builders First Source.
 - Immediately contact Builders First Source if trusses are damaged.
- Connection Notes:**
- All hangers are to be Simpson or equivalent U.N.O.
 - Use Manufacturer's specifications for all hanger connections U.N.O.
 - Use 10d x 1 1/2" Nails in hanger connections to single ply roof girder trusses.
- Floor notes:**
- Shift truss as required to avoid plumbing traps.
 - Installation Contractor and/or Field Supervisor are to verify all dimensions, trap locations, and options prior to installation
- Dimension Notes:**
- Drawing not to scale. Do not scale dimensions

△ ◁ ▷ ▽ LEFT END OF TRUSS AS SHOWN ON TRUSS DETAIL DRAWINGS ARE INDICATED BY TRIANGLE ICONS.

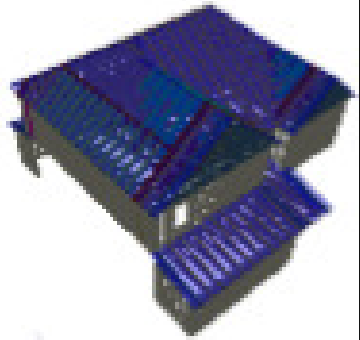

HANGER LIST		ALL TIE DOWNS H2.5A UNLESS NOTED	
23	HTU26	M16	16
42	LUS24	L14	14
1	LGT2	JL	14

SPECIAL ITEMS LIST	
MISC MATERIAL	

DAVIDSON	
WILLOW	ELEV: C
WELLER'S KNOLL	
HARNETT	LOT: 88
APPWRIGHT #	
4440329	
CODE: IRC 2015	
LOADING:	
T.C.L.L.	20 PSF
DESIGNED BY:	TG
T.C.D.L.	10 PSF
LAYOUT:	WK88
B.C.L.L.	0 PSF
L/O DATE:	2/3/2025
B.C.D.L.	10 PSF

REVISION HISTORY		WIND:	
REV1:	XX/XX/XX	M.P.H.	120 MPH
REV2:	XX/XX/XX	EXPOSURE CATEGORY	
REV3:	XX/XX/XX	B (WOODED AREAS/OTHERS)	
PICK TICKET:	-	JOB NO:	WK88
SALES NO:	-	ACCT NO:	-

HATCH LEGEND	
△ △ △ △	ATTIC ROOM
▨ ▨ ▨ ▨	VOLUME CEILING
▩ ▩ ▩ ▩	STICK FRAMING