

FRONT ELEVATION 3

SCALE: 1/8" = 1'-0"

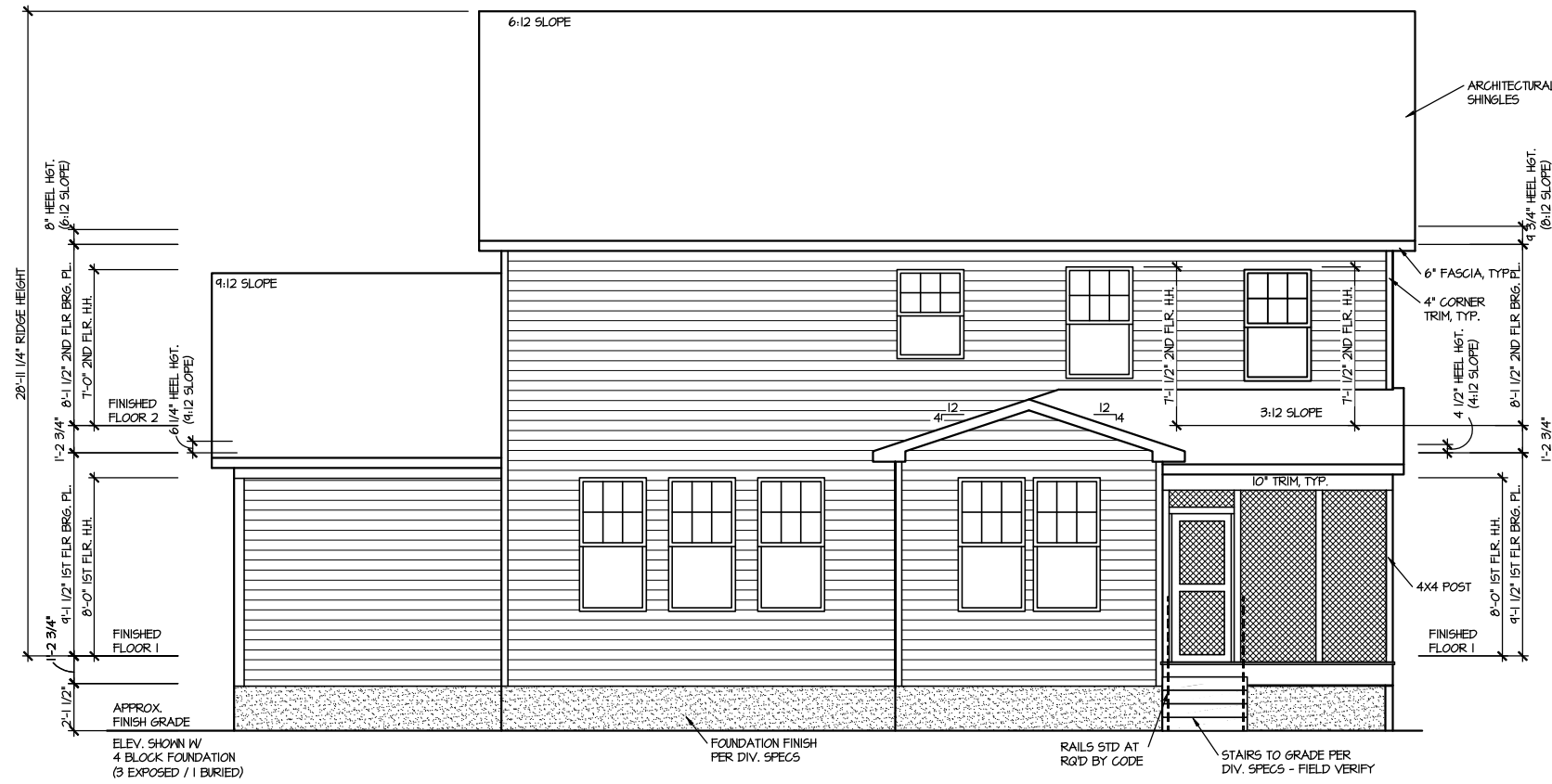

REAR ELEVATION 3

SCALE: 1/8" = 1'-0"

MASTER PLAN INFORMATION	
REVISION	DATE
2-RALE	03-06-2019
UPDATED DATE	04-26-2024

DRAWN BY:	ITS
DATE:	01/16/2024
PLAN NO.	2695



HOUSE NAME:
DRAYTON
DRAWING TITLE
FRONT & REAR ELEVATIONS

SHEET No.
A.1

FILE: Lot_00.0029_amendment.dwg DATE: 1/16/2025 3:47 PM

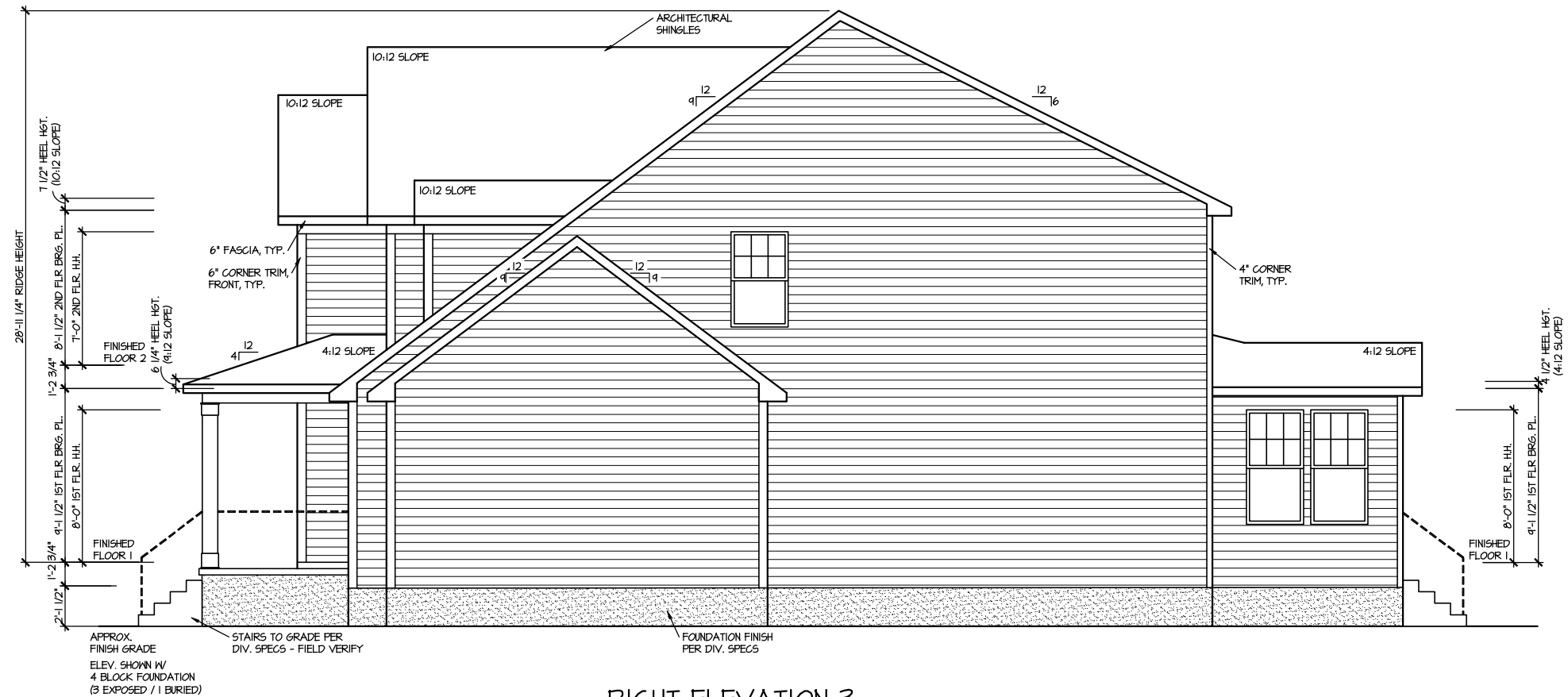

RIGHT ELEVATION 3

SCALE: 1/8" = 1'-0"

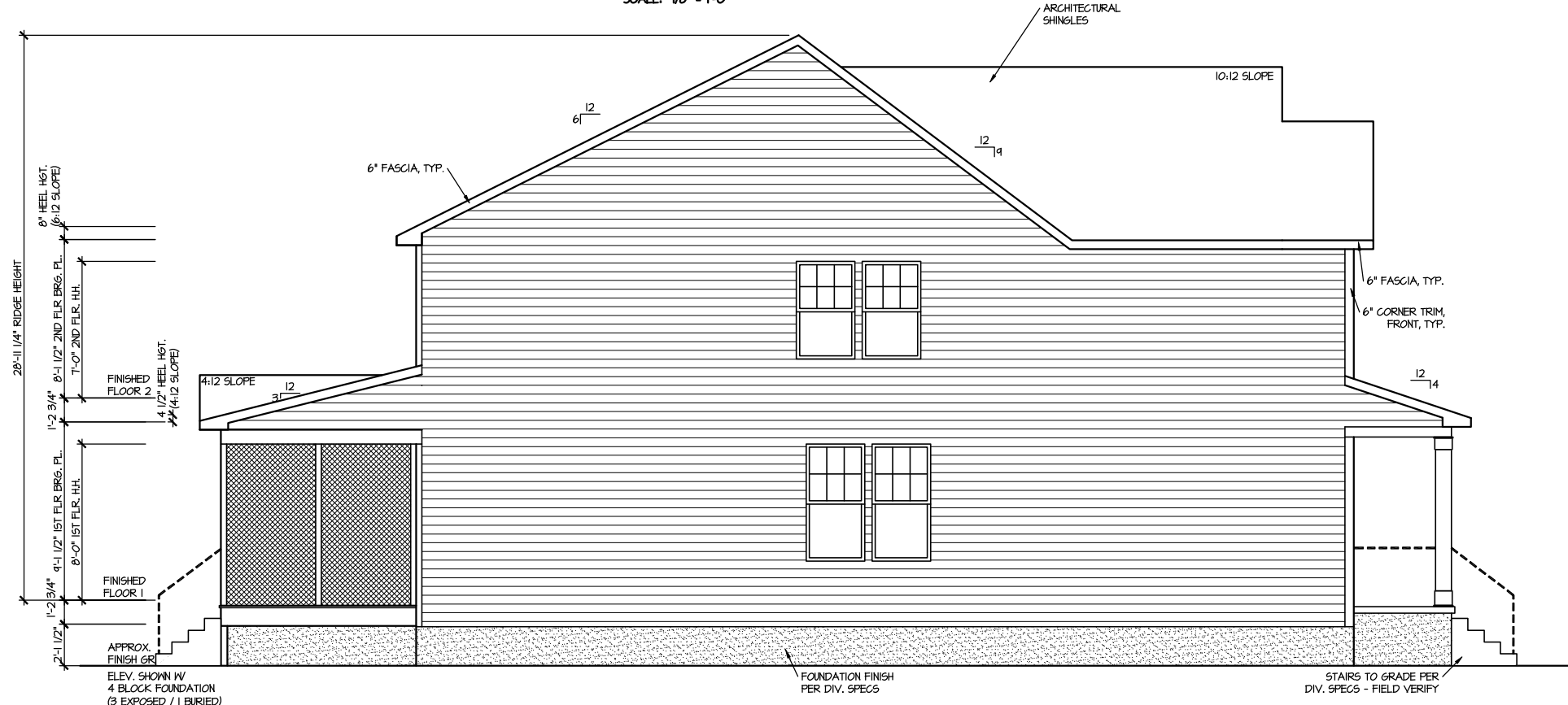

LEFT ELEVATION 3

SCALE: 1/8" = 1'-0"

MASTER PLAN INFORMATION	
DATE	03-06-2019
REVISION	2--RALE
UPDATED DATE	04-26-2024

DRAWN BY:	ITS
DATE:	01/16/2024
PLAN NO.	2695



HOUSE NAME:
DRAYTON
DRAWING TITLE
RIGHT & LEFT ELEVATIONS

SHEET No.
A1.2

ROOF VENTILATION CALCULATIONS:

ROOF AREA = 1836 SQ. FT.
 OVERALL REQUIRED VENTILATION:
 1 TO 150 = 12.24 SQ. FT.
 1 TO 300 = 6.12 SQ. FT.
 50-80% IN TOP THIRD = 3.06- 4.90 FT. (1 TO 300)
 NET FREE AREA OF VENTED SOFFIT = 5.7 SQ. IN. / LINEAR FT.
 NET FREE AREA OF RIDGE VENT = 18 SQ. IN. / LINEAR FT.
 LOWER VENTING: (BOTTOM 2/3 RDS)
 77 LINEAR FEET OF SOFFIT X 5.7 SQ. IN. = 3.05 SQ. FT.
 UPPER VENTING: (TOP 1/3 RD)
 26 LINEAR FEET OF RIDGE X 18 SQ. IN. = 3.25 SQ. FT.
 3.25 SQ. FT. BETWEEN 50% - 80%
 (1 TO 300 ALLOWED)
 TOTAL ROOF VENTILATION: 6.3 SQ. FT. > 6.12 SQ. FT. (RQ'D)

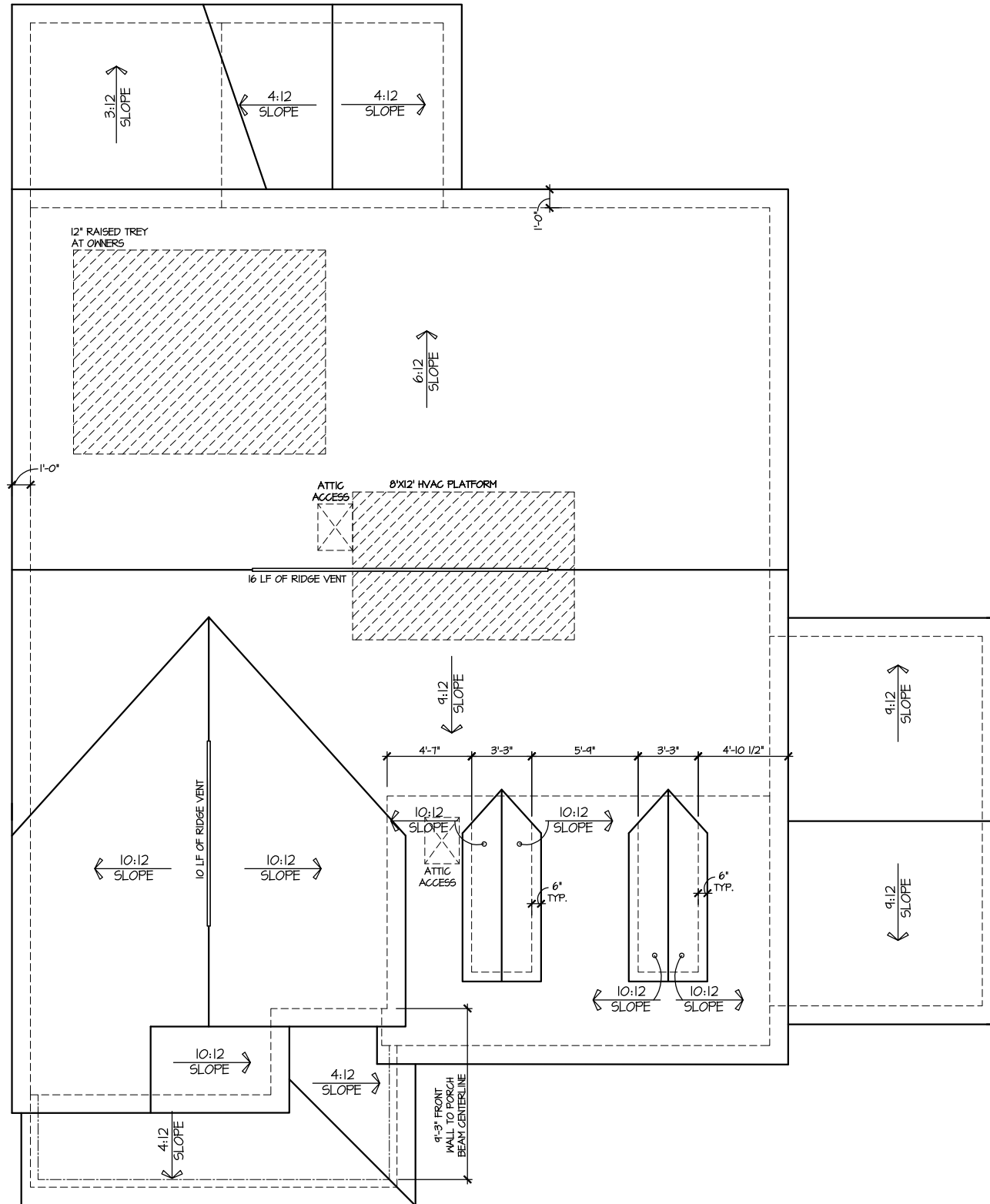

ROOF PLAN ELEV. 3

SCALE: 1/8" = 1'-0"

FILE: Lot_00.0029 amendment.dwg DATE: 1/16/2025 3:47 PM

UPDATED DATE
04-26-2024

MASTER PLAN INFORMATION
 REVISION DATE
 2-RALE 03-06-2019

DRAWN BY:
ITS
 DATE:
01/16/2024
 PLAN NO.
2695



HOUSE NAME:
DRAYTON
 DRAWING TITLE
ROOF PLAN

SHEET No.
A.3

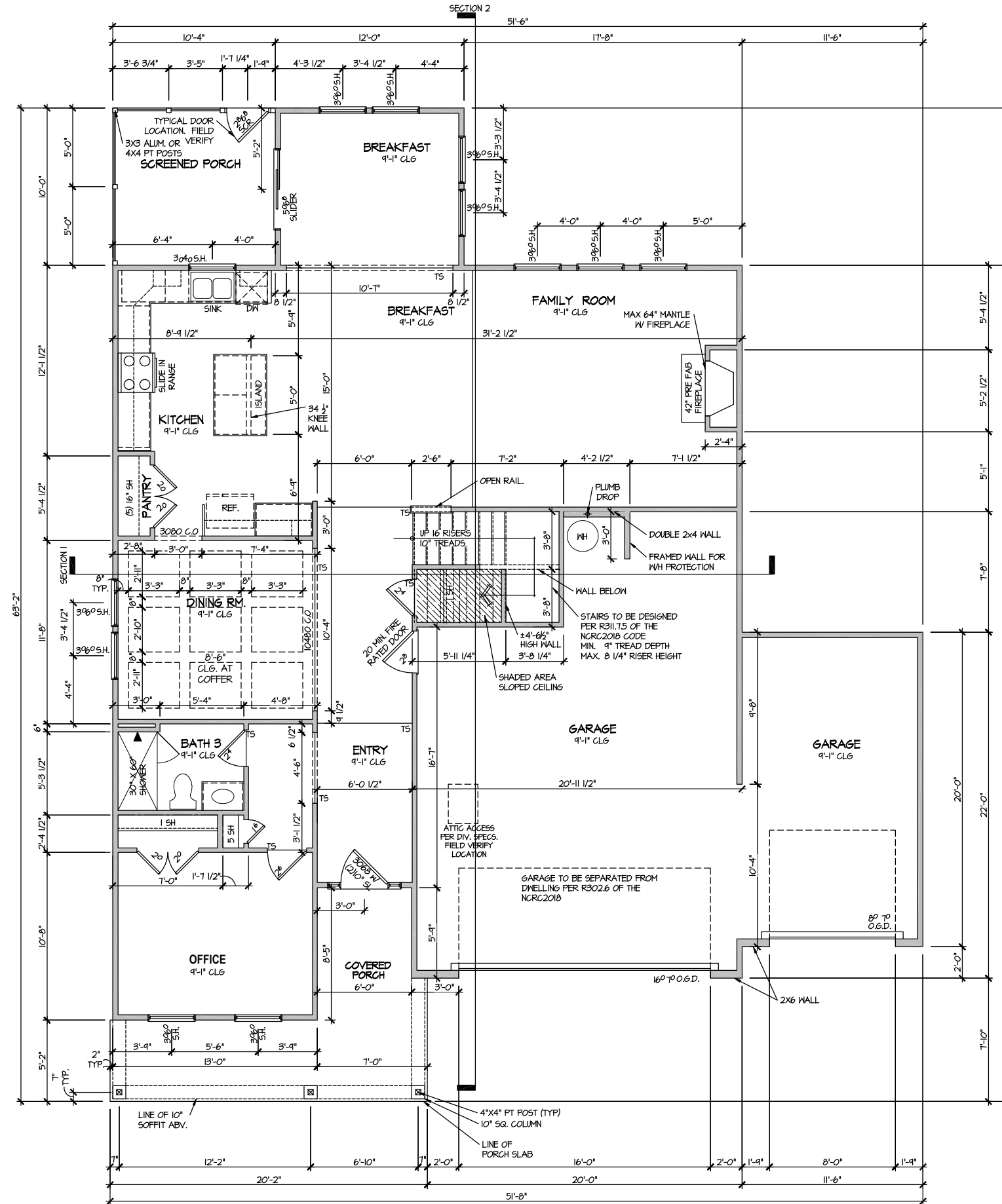

**ELEVATION 3
FIRST FLOOR PLAN**

SCALE: 1/8" = 1'-0"

FILE: Lot_00.0029_amendment.dwg DATE: 1/16/2025 3:47 PM

MASTER PLAN INFORMATION	
REVISION	DATE
2-RALE	03-06-2019
	UPDATED DATE
	04-26-2024

DRAWN BY:
ITS
DATE: 01/16/2024
PLAN NO.
2695

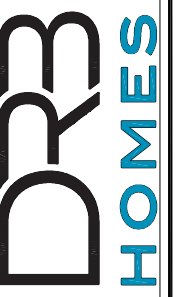

HOUSE NAME:
DRAYTON
DRAWING TITLE
FIRST FLOOR PLAN

SHEET No.
A3.1

FILE: Lot_00.0029_amendment.dwg DATE: 1/16/2025 3:47 PM

ELEVATION 3 SECOND FLOOR PLAN

SCALE: 1/8" = 1'-0"

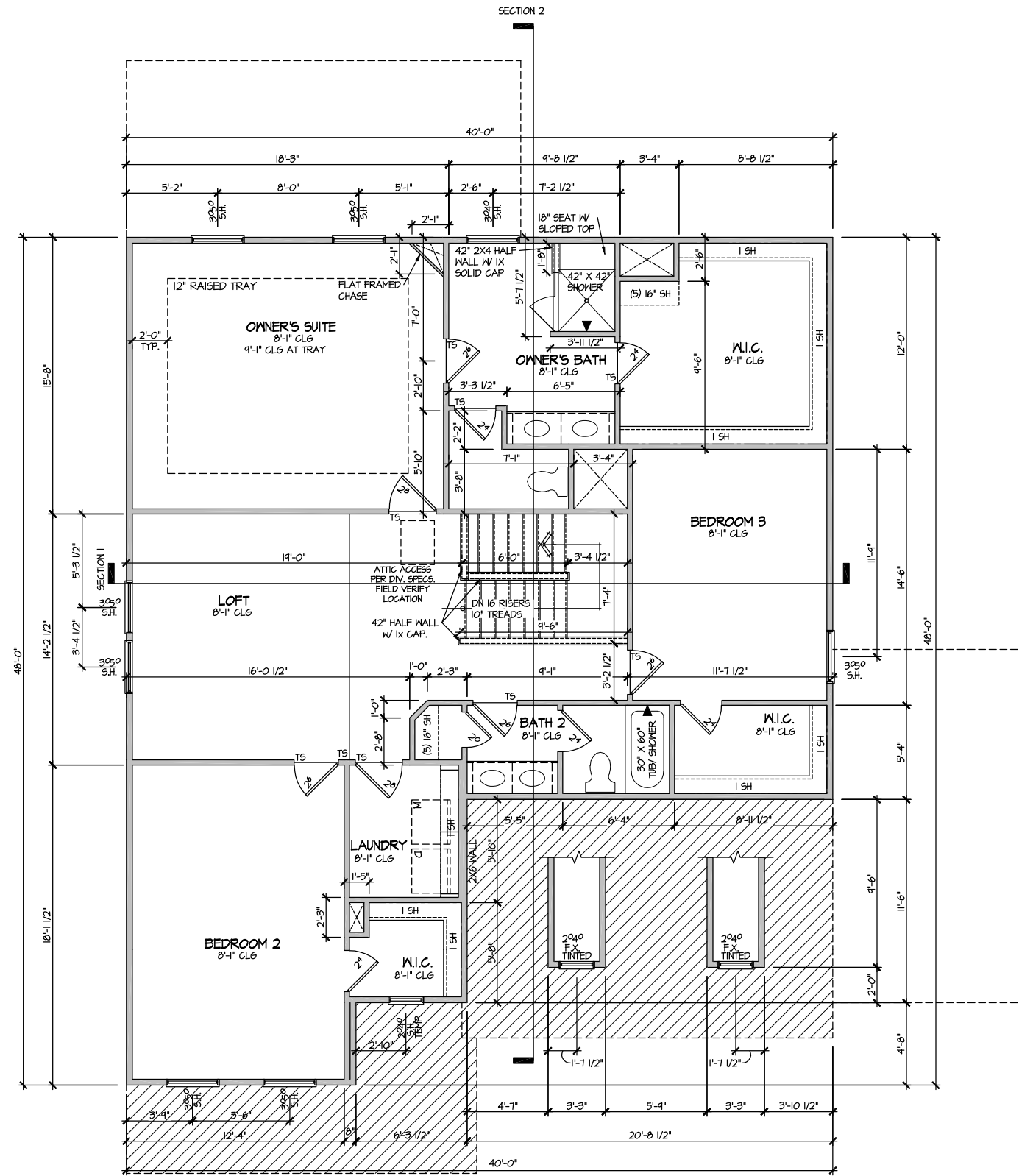

REVISION	DATE	UPDATED DATE
2-RALE	03-06-2019	04-26-2024

MASTER PLAN INFORMATION		
REVISION	DATE	UPDATED DATE
2-RALE	03-06-2019	04-26-2024

DRAWN BY:	ITS
DATE:	01/16/2024
PLAN NO.	2695



HOUSE NAME:
DRAYTON

DRAWING TITLE
SECOND FLOOR PLAN

SHEET No.
A3.2

FILE: Lot_00.0029 amendment.dwg DATE: 1/16/2025 3:47 PM

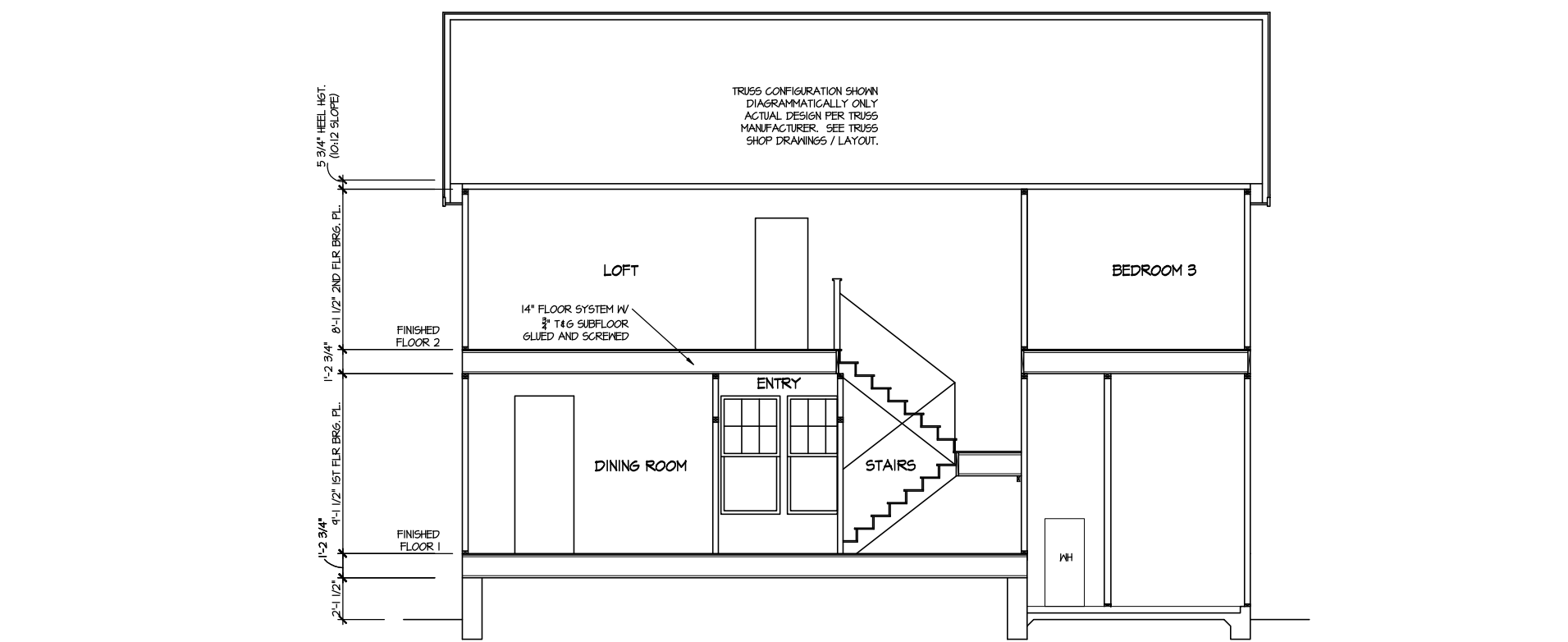

SECTION I
SCALE: 1/8" = 1'-0"

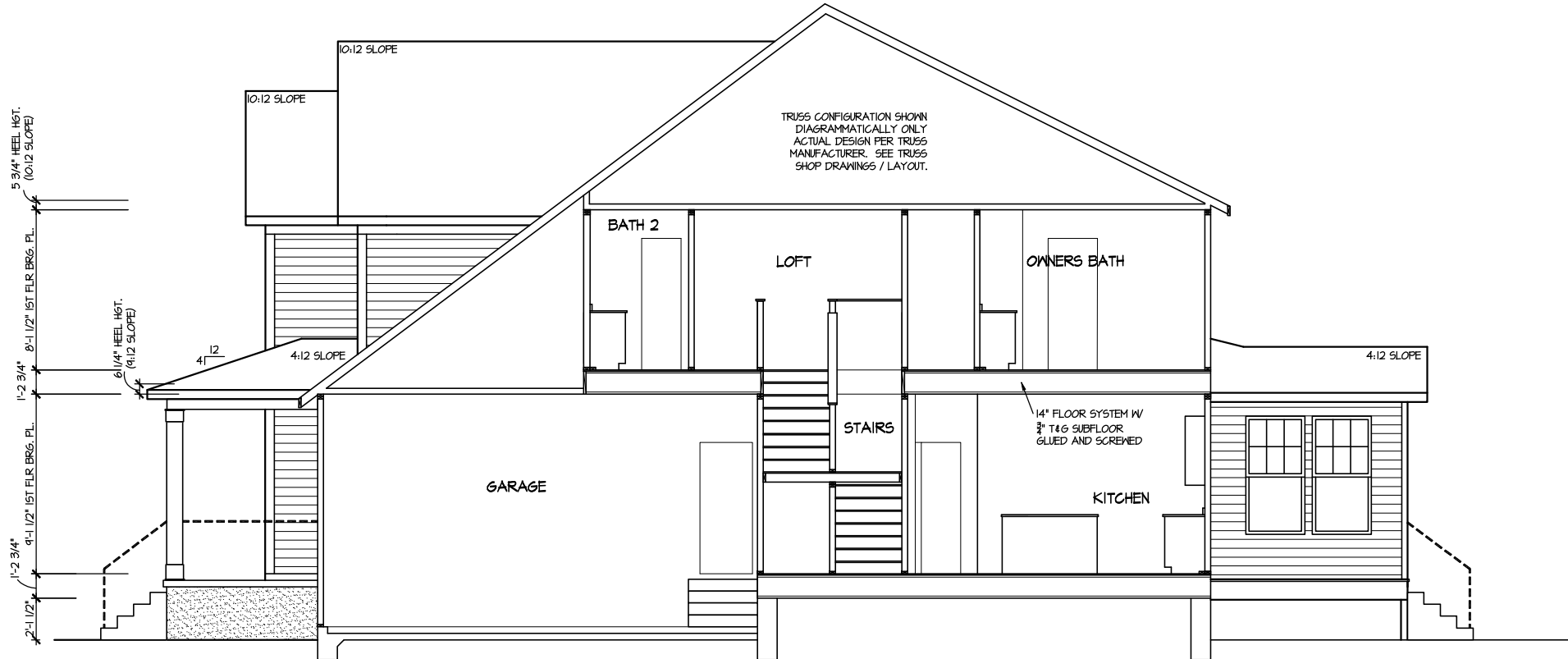

SECTION 2
SCALE: 1/8" = 1'-0"

MASTER PLAN INFORMATION	
REVISION	DATE
2-RALE	03-06-2019
UPDATED DATE	04-26-2024

DRAWN BY:	ITS
DATE:	01/16/2024
PLAN NO.	2695



HOUSE NAME:
DRAYTON

DRAWING TITLE
BUILDING SECTION

SHEET No.
A4.1

ELECTRICAL LEGEND

- Ⓢ SINGLE POLE SWITCH
- Ⓢ₃ THREE WAY SWITCH
- Ⓢ₄ FOUR WAY SWITCH
- Ⓢ- DUPLEX AFCI RECEPTACLE
- Ⓢ- DUPLEX AFCI RECEPTACLE - BOTTOM HALF SWITCHED
- Ⓢ- DUPLEX AFCI RECEPTACLE - FLOOR MOUNTED
- 220V Ⓢ RECEPTACLE - 220V
- GFI Ⓢ DUPLEX AFCI RECEPTACLE - GFI
- WP/GFI Ⓢ DUPLEX AFCI RECEPTACLE - WATERPROOF GFI
- Ⓢ SMOKE DETECTOR - WIRED IN SERIES
- Ⓢ EXHAUST FAN MOTOR
- Ⓢ CO DETECTOR
- Ⓢ DOOR CHIME
- Ⓢ LIGHT FIXTURE - WALL MOUNTED
- Ⓢ LIGHT FIXTURE - CEILING MOUNTED
- Ⓢ LED LIGHT FIXTURE - LED SURFACE MOUNTED
- Ⓢ LED FULLCHAIN LAMPHOLDER
- Ⓢ KEYLESS LAMPHOLDER

NOTE: ALL ELECTRICAL WORK SHALL CONFORM TO THE REQUIREMENTS OF THE ADOPTED VERSION OF THE NATIONAL ELECTRICAL CODE, THE LOCAL POWER COMPANY AND TO ALL APPLICABLE LOCAL REGULATIONS.

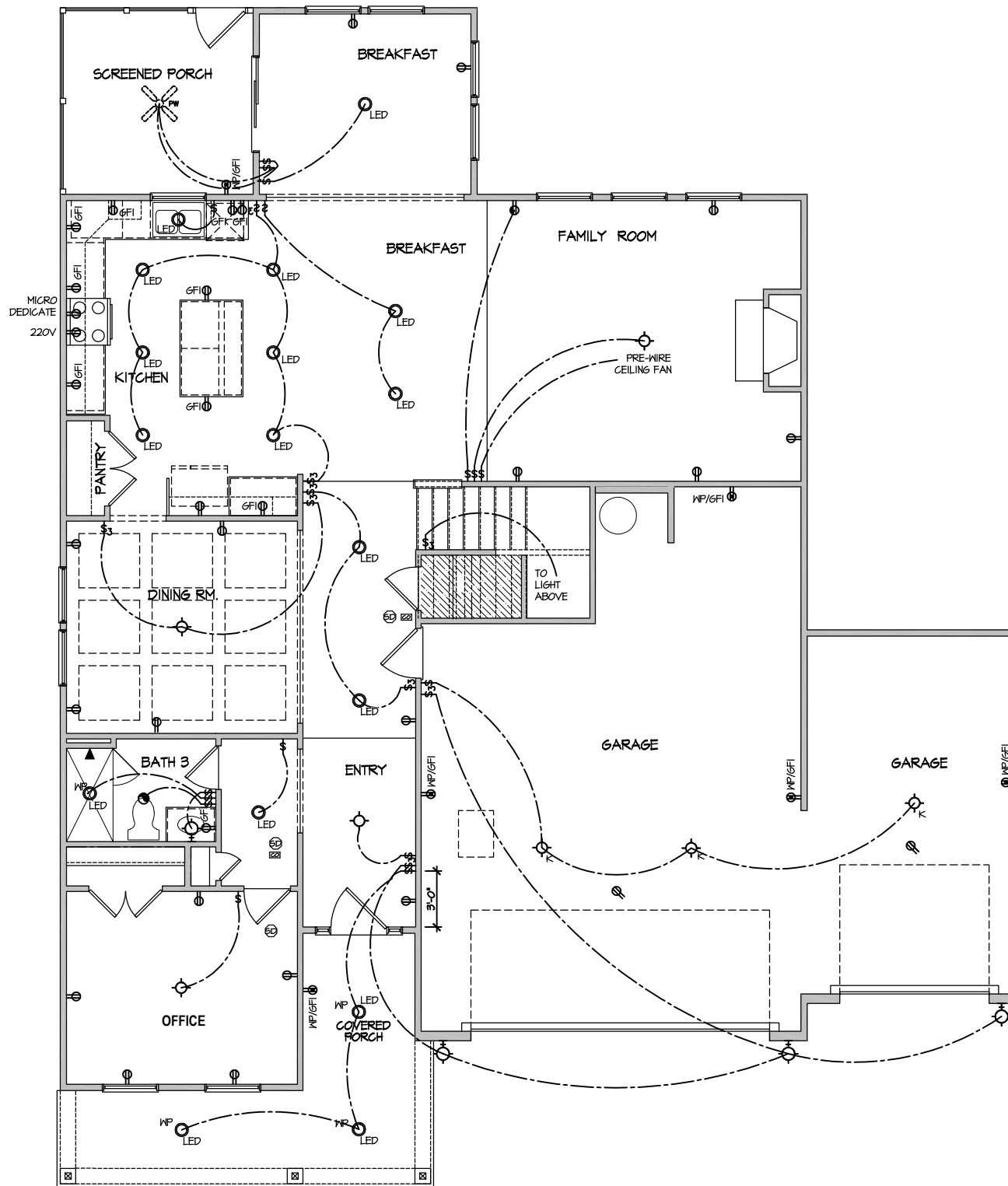

**ELECTRICAL PLAN
FIRST FLOOR - ELEV. 3**

SCALE: 1/8" = 1'-0"

FILE: Lot_00.0029 amendment.dwg DATE: 1/16/2025 3:47 PM

UPDATED DATE
04-26-2024

MASTER PLAN INFORMATION
DATE 03-06-2019
REVISION 2-RALE

DRAWN BY: ITS
DATE: 01/16/2024
PLAN NO. 2695



HOUSE NAME: DRAYTON
DRAWING TITLE: FIRST FLOOR ELECTRICAL

SHEET No.
1

ELECTRICAL LEGEND

- Ⓢ SINGLE POLE SWITCH
- Ⓢ₃ THREE WAY SWITCH
- Ⓢ₄ FOUR WAY SWITCH
- ⓈⓈ DUPLEX AFCI RECEPTACLE
- ⓈⓈ₃ DUPLEX AFCI RECEPTACLE - BOTTOM HALF SWITCHED
- ⓈⓈ₄ DUPLEX AFCI RECEPTACLE - FLOOR MOUNTED
- 220V Ⓢ RECEPTACLE - 220V
- GFI Ⓢ DUPLEX AFCI RECEPTACLE - GFI
- WP/GFI Ⓢ DUPLEX AFCI RECEPTACLE - WATERPROOF GFI
- ⓈⓈ SMOKE DETECTOR - WIRED IN SERIES
- Ⓢ EXHAUST FAN MOTOR
- Ⓢ CO DETECTOR
- Ⓢ DOOR CHIME
- Ⓢ LIGHT FIXTURE - WALL MOUNTED
- Ⓢ LIGHT FIXTURE - CEILING MOUNTED
- LED LIGHT FIXTURE - LED SURFACE MOUNTED
- Ⓢ_P FULLCHAIN LAMPHOLDER
- Ⓢ_K KEYLESS LAMPHOLDER

NOTE: ALL ELECTRICAL WORK SHALL CONFORM TO THE REQUIREMENTS OF THE ADOPTED VERSION OF THE NATIONAL ELECTRICAL CODE, THE LOCAL POWER COMPANY AND TO ALL APPLICABLE LOCAL REGULATIONS.

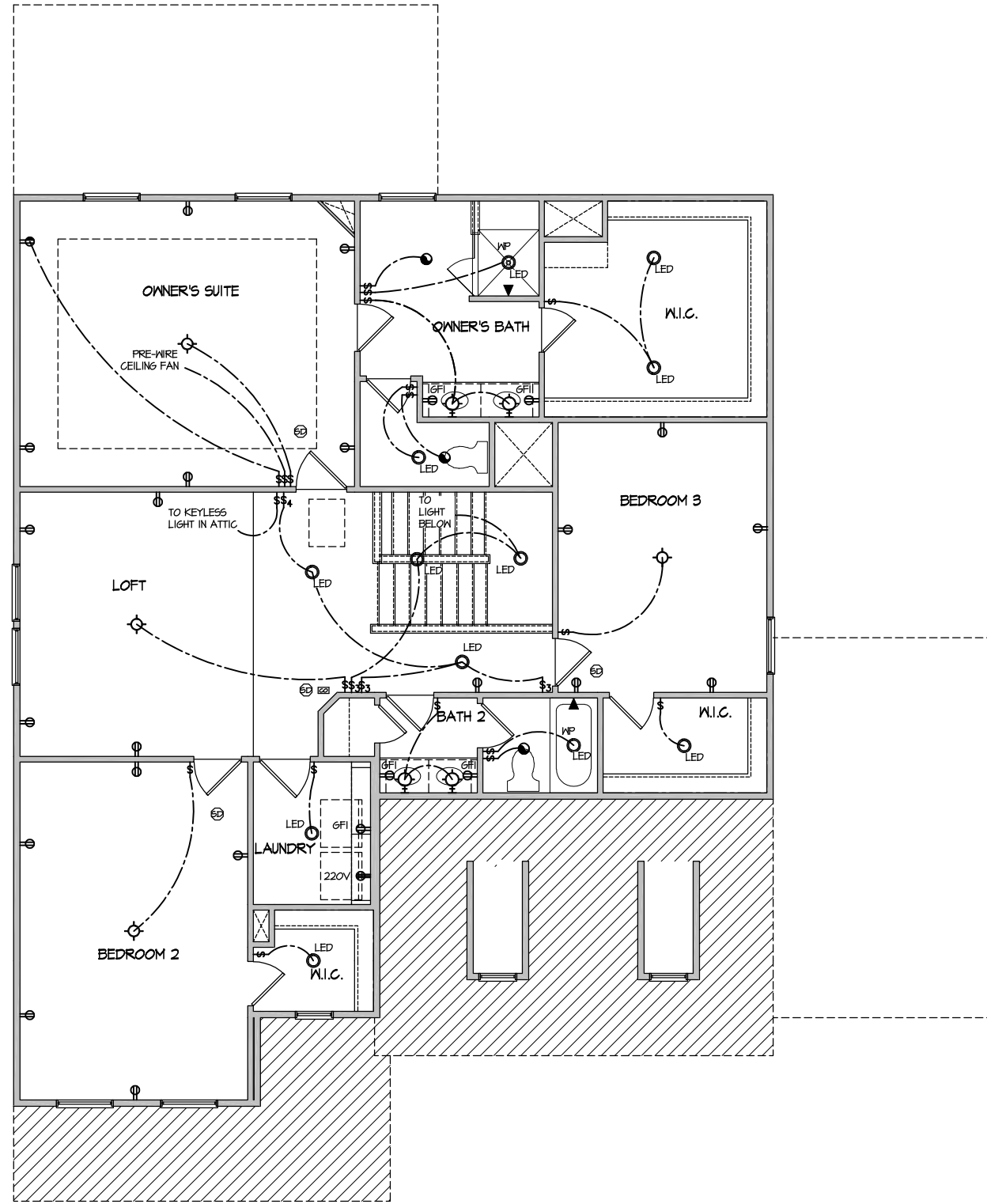

ELECTRICAL PLAN
SECOND FLOOR - ELEV. 3
 SCALE: 1/8" = 1'-0"

FILE: Lot_00.0029 amendment.dwg DATE: 1/16/2025 3:47 PM

MASTER PLAN INFORMATION
 DATE 03-06-2019
 REVISION 2-RALE

UPDATED DATE 04-26-2024

DRAWN BY: ITS
 DATE: 01/16/2024
 PLAN NO. 2695



HOUSE NAME: DRAYTON
 DRAWING TITLE: SECOND FLOOR ELECTRICAL

SHEET No. 1.2



SEAL

DRAWN BY:
L. BEAVERS
DATE: 9/1/22
PLAN NO.
11 X 17 SCALE
24 X 36 SCALE



HOUSE NAME:
DRAWING TITLE
RALE TILE SHOWER DETAIL

SHEET No.
01.12



RALE TILE SHOWER SECTION B
SCALE: 1/2" = 1'-0"



RALE TILE SHOWER SECTION C
SCALE: 1/2" = 1'-0"

ALL DIMENSIONS ARE TO FRAMING

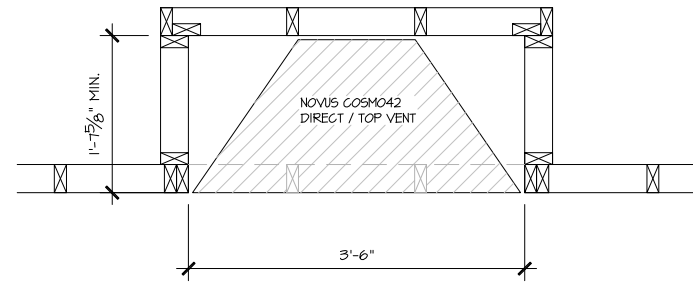

PARTIAL PLAN
NOVUS COSMO42

SCALE: 1/2" = 1'-0"

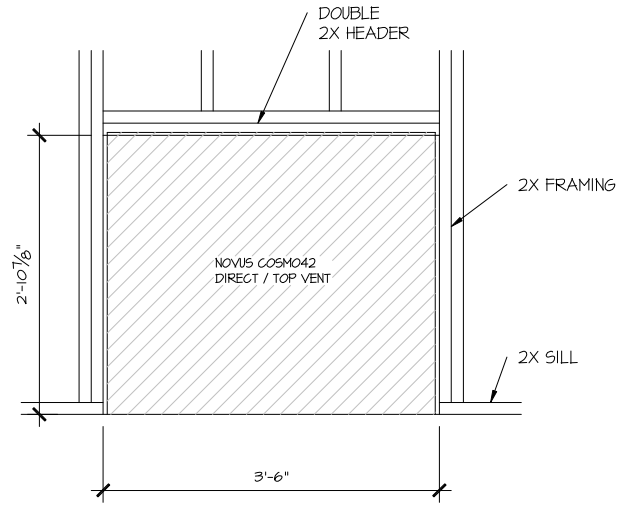

PARTIAL ELEVATION
NOVUS COSMO42

SCALE: 1/2" = 1'-0"

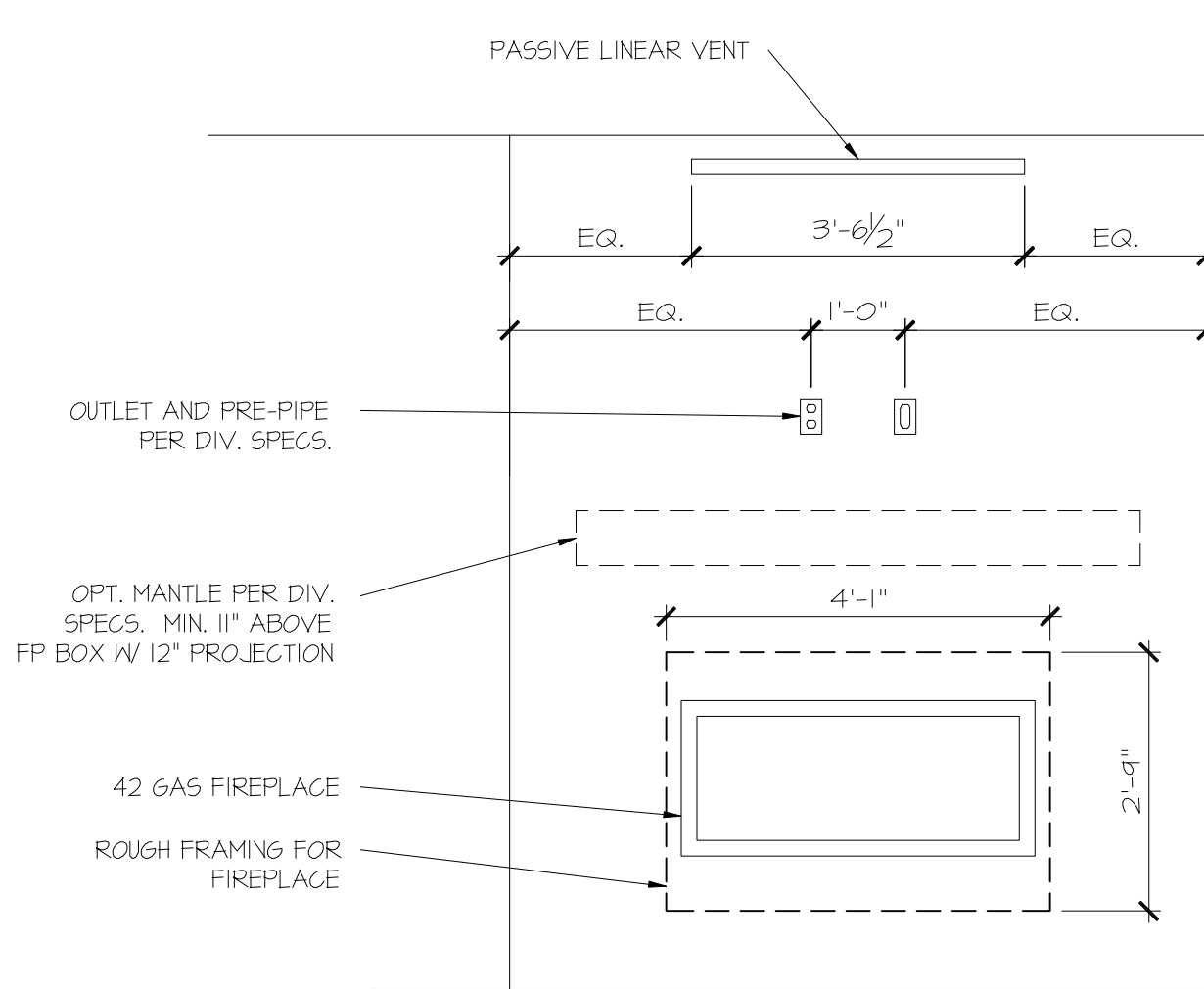

PARTIAL ELEVATION
NOVUS COSMO42

SCALE: 1/2" = 1'-0"

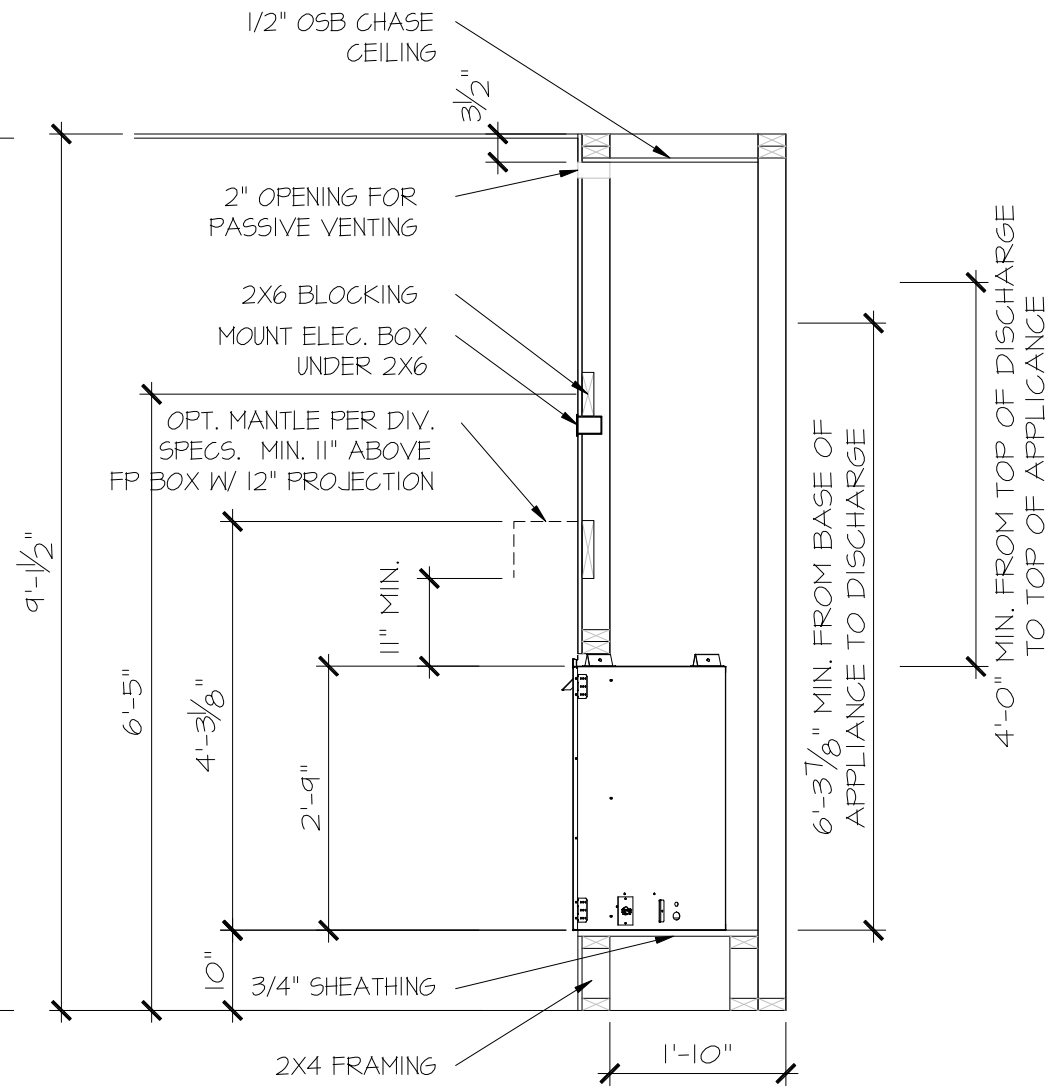

PARTIAL SECTION
NOVUS COSMO42

SCALE: 1/2" = 1'-0"

FILE: RALE FIREPLACE DETAILS 11-8-23.dwg DATE: 5/27/2022 10:35 AM

CONSULTANT LOGO

SEAL

DRAWN BY:
L. BEAVERS
DATE: 11-8-23
PLAN NO.
N/A
11 X 17 SCALE
24 X 36 SCALE



HOUSE NAME:
RALE FIREPLACE DETAILS
DRAWING TITLE
RALE FIREPLACE DETAIL
INTERIOR GAS UNITS

SHEET No.
10

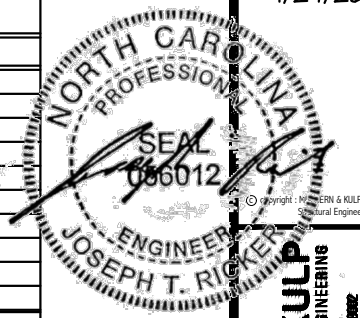

MULHERN+KULP
RESIDENTIAL STRUCTURAL ENGINEERING
388 Danville Ave., Building 4 - Danville, VA 24040
P: 753-948-5200 | F: 753-948-5201 | mulhern+kulp.com
NC LICENSE #C-3825



M&K project number:
126-23047
project mgr.: JTR
drawn by: JAD
issue date: 01-27-24
REVISIONS:
date: initial:

STRUCTURAL NOTES
HONEYCUTT HILLS
LOT 29 - DRAYTON 3
RALEIGH, NC

STRUCTURAL NOTES
HONEYCUTT HILLS
LOT 29 - DRAYTON 3
RALEIGH, NC

STRUCTURAL NOTES
HONEYCUTT HILLS
LOT 29 - DRAYTON 3
RALEIGH, NC

STRUCTURAL NOTES
HONEYCUTT HILLS
LOT 29 - DRAYTON 3
RALEIGH, NC

SO.0

VENEER LINTEL SCHEDULE

SPAN (MAX)	HEIGHT OF VENEER ABOVE LINTEL	STEEL ANGLE SIZE
3'-0"	20 FT. MAX	L3"x3"x1/4"
6'-0"	3 FT. MAX	L3"x3"x1/4"
	12 FT. MAX	L4"x3"x1/4"
	20 FT. MAX	L5"x3"x3/8"
8'-0"	3 FT. MAX	L4"x4"x1/4"
	12 FT. MAX	L5"x3"x3/8"
	16 FT. MAX	L6"x3"x3/8"
9'-6"	12 FT. MAX	L6"x3"x3/8"
	2 FT. MAX	L7"x4"x1/2"
16'-0"	3 FT. MAX	L8"x4"x1/2"
		L8"x4"x1/2"

ALL LINTELS:
 - SHALL SUPPORT 2 1/2" x 3/8" VENEER w/ 40 psf MAXIMUM HEIGHT.
 - 1/4" MIN. BEARING
 - 1/2" MIN. BEARING
 - 3/4" MIN. BEARING
 - 1" MIN. BEARING
 - 1 1/4" MIN. BEARING
 - 1 1/2" MIN. BEARING
 - 1 3/4" MIN. BEARING
 - 2" MIN. BEARING
 - 2 1/4" MIN. BEARING
 - 2 1/2" MIN. BEARING
 - 2 3/4" MIN. BEARING
 - 3" MIN. BEARING
 - 3 1/4" MIN. BEARING
 - 3 1/2" MIN. BEARING
 - 3 3/4" MIN. BEARING
 - 4" MIN. BEARING
 - 4 1/4" MIN. BEARING
 - 4 1/2" MIN. BEARING
 - 4 3/4" MIN. BEARING
 - 5" MIN. BEARING
 - 5 1/4" MIN. BEARING
 - 5 1/2" MIN. BEARING
 - 5 3/4" MIN. BEARING
 - 6" MIN. BEARING
 - 6 1/4" MIN. BEARING
 - 6 1/2" MIN. BEARING
 - 6 3/4" MIN. BEARING
 - 7" MIN. BEARING
 - 7 1/4" MIN. BEARING
 - 7 1/2" MIN. BEARING
 - 7 3/4" MIN. BEARING
 - 8" MIN. BEARING
 - 8 1/4" MIN. BEARING
 - 8 1/2" MIN. BEARING
 - 8 3/4" MIN. BEARING
 - 9" MIN. BEARING
 - 9 1/4" MIN. BEARING
 - 9 1/2" MIN. BEARING
 - 9 3/4" MIN. BEARING
 - 10" MIN. BEARING
 - 10 1/4" MIN. BEARING
 - 10 1/2" MIN. BEARING
 - 10 3/4" MIN. BEARING
 - 11" MIN. BEARING
 - 11 1/4" MIN. BEARING
 - 11 1/2" MIN. BEARING
 - 11 3/4" MIN. BEARING
 - 12" MIN. BEARING
 - 12 1/4" MIN. BEARING
 - 12 1/2" MIN. BEARING
 - 12 3/4" MIN. BEARING
 - 13" MIN. BEARING
 - 13 1/4" MIN. BEARING
 - 13 1/2" MIN. BEARING
 - 13 3/4" MIN. BEARING
 - 14" MIN. BEARING
 - 14 1/4" MIN. BEARING
 - 14 1/2" MIN. BEARING
 - 14 3/4" MIN. BEARING
 - 15" MIN. BEARING
 - 15 1/4" MIN. BEARING
 - 15 1/2" MIN. BEARING
 - 15 3/4" MIN. BEARING
 - 16" MIN. BEARING
 - 16 1/4" MIN. BEARING
 - 16 1/2" MIN. BEARING
 - 16 3/4" MIN. BEARING
 - 17" MIN. BEARING
 - 17 1/4" MIN. BEARING
 - 17 1/2" MIN. BEARING
 - 17 3/4" MIN. BEARING
 - 18" MIN. BEARING
 - 18 1/4" MIN. BEARING
 - 18 1/2" MIN. BEARING
 - 18 3/4" MIN. BEARING
 - 19" MIN. BEARING
 - 19 1/4" MIN. BEARING
 - 19 1/2" MIN. BEARING
 - 19 3/4" MIN. BEARING
 - 20" MIN. BEARING

MEANS & METHODS NOTES

THE STRUCTURE IS DESIGNED TO BE SELF SUPPORTING AND STABLE AFTER THE BUILDING IS FINISHED AND ALL PLAN, DETAIL, AND NOTE SPECIFICATIONS HAVE BEEN COMPLETED. IT IS THE CONTRACTOR'S SOLE RESPONSIBILITY TO DETERMINE THE ERECTION PROCEDURES AND SEQUENCE TO INSURE THE SAFETY OF THE BUILDING AND ITS COMPONENTS DURING CONSTRUCTION. THIS INCLUDES, BUT IS NOT LIMITED TO, THE ADDITION OF NECESSARY SHORING, SHEETING, TEMPORARY BRACING, GUY, AND TIE-DOWNS. CONTRACTOR SHALL BE RESPONSIBLE FOR ALL SHORING AND BRACING REQUIRED TO STABILIZE AND PROTECT EXISTING AND ADJACENT STRUCTURES AND SYSTEMS DURING COURSE OF DEMOLITION AND CONSTRUCTION OF THE PROJECT.

STRUCTURAL DESIGN AND SPECIFICATIONS ASSUME THAT ALL SUPPORTING AND NON-SUPPORTING ELEMENTS IN CONTACT WITH FLOOR FRAMING ARE LEVEL, INCLUDING, BUT NOT LIMITED TO: FOUNDATIONS, SLABS ON GRADE, BEAMS, WALLS, AND NON-BEARING ELEMENTS. IT IS THE CONTRACTOR'S RESPONSIBILITY TO VERIFY LEVELNESS AND MAKE ADJUSTMENTS AS NECESSARY, INCLUDING CONSIDERATION OF THOSE AREAS THAT MAY BE WITHIN CONTRACTUAL, INDUSTRY, OR WARRANTY TOLERANCES.

ADDITIONAL NOTES FOR TRUSS & I-JOIST MANUFACTURER

ROOF TRUSS, FLOOR TRUSS AND ENGINEERED JOISTS SHALL BE DESIGNED TO MEET THE DIFFERENTIAL DEFLECTION CRITERIA BELOW, UNLESS NOTED OTHERWISE ON PLAN.

TRUSSES/JOISTS SHALL BE DESIGNED SO THAT DIFFERENTIAL DEFLECTION BETWEEN ADJACENT PARALLEL TRUSSES/JOISTS OR GIRDER TRUSSES/FLUSH BEAMS DO NOT EXCEED THE FOLLOWING:

- ROOF TRUSSES:
1/4" DEAD LOAD
- FLOOR TRUSSES, ATTIC TRUSSES, & I-JOISTS:
1/8" DEAD LOAD
- FLOOR TRUSSES & ATTIC TRUSSES ADJACENT TO FLOOR FRAMING BY OTHERS:
LIMIT ABSOLUTE TRUSS DEFLECTION TO 3/16" DEAD LOAD. (NOT DIFFERENTIAL DEFLECTION)

ENGINEERED BEAM MATERIAL SCHEDULE

BEAM NUMBER	LVL OPTION	PSL OPTION	LSL OPTION	FLITCH OPTION	STEEL OPTION
001	(2)3/4"x14" - F	3/2"x14" - F	(2)3/4"x14" - F	(2)2x12 + (1)3/8"x10 1/2" STEEL FLITCH PLATES - FB	M12x14 - F
002	(2)3/4"x14" - F	3/2"x14" - F	(2)3/4"x14" - F	(2)2x12 + (1)3/8"x10 1/2" STEEL FLITCH PLATES - FB	M12x14 - F
003	(3)3/4"x10" - FB or (2)3/4"x20" - FB	5/4"x10" - FB	N/A	(3)2x12 + (2)3/8"x10 1/2" STEEL FLITCH PLATES - FB	M12x26 - F
004	(2)3/4"x14" - F	3/2"x14" - F	(2)3/4"x14" - F	(2)2x12 + (1)3/8"x10 1/2" STEEL FLITCH PLATES - FB	M12x14 - F
005	(2)3/4"x17 1/2" - H cont.	3/2"x17 1/2" - H cont.	(2)3/4"x17 1/2" - H cont.	(3)2x12 + (2)3/8"x10 1/2" STEEL FLITCH PLATES - H cont.	N/A
005A	(3)3/4"x14" - H cont.	3/4"x14" - H cont.	N/A	(3)2x12 + (2)3/8"x10 1/2" STEEL FLITCH PLATES - H cont.	N/A
006	(1)3/4"x14" - F	3/2"x14" - F	(2)3/4"x14" - F	(2)2x12 + (1)3/8"x10 1/2" STEEL FLITCH PLATES - FB	M12x14 - F
007	(2)3/4"x17 1/2" - D	3/2"x17 1/2" - D	(2)3/4"x17 1/2" - D	(2)2x12 + (1)3/8"x10 1/2" STEEL FLITCH PLATES - D	M10x12 - D
008	(2)3/4"x16" - H cont.	3/2"x16" - H cont.	(3)3/4"x16" - H cont.	(3)2x12 + (2)3/8"x10 1/2" STEEL FLITCH PLATES - H cont.	N/A
009	(2)3/4"x4" - F	3/2"x4" - F	(2)3/4"x4" - F	(2)2x10 + (1)3/8"x4" STEEL FLITCH PLATES - F	M8x10 - F
010	(2)3/4"x14" - F	3/2"x14" - F	(2)3/4"x14" - F	(2)2x12 + (1)3/8"x10 1/2" STEEL FLITCH PLATES - FB	M12x14 - F
011	(2)3/4"x14" - F	3/2"x14" - F	(2)3/4"x14" - F	(2)2x12 + (1)3/8"x10 1/2" STEEL FLITCH PLATES - FB	M12x14 - F
012	(2)3/4"x17 1/2" - D	3/2"x17 1/2" - D	(2)3/4"x17 1/2" - D	(2)2x12 + (1)3/8"x10 1/2" STEEL FLITCH PLATES - D	M10x12 - D

BEAM NOTATION:
 - "F" INDICATES FLUSH BEAM
 - "FT" INDICATES FLUSH TOP BEAM
 - "FB" INDICATES FLUSH BOTTOM BEAM
 - "D" INDICATES DROPPED BEAM
 - "H" INDICATES DROPPED OPENING HEADER

REFER TO DETAIL D/SD2.0 FOR TYPICAL FLITCH BEAM CONNECTIONS
 REFER TO DETAIL E/SD2.0 FOR TYPICAL STEEL BEAM CONNECTIONS
 FOR FLUSH TOP BEAMS PROVIDE 2X STACKED PLATES BENEATH BEAM AS REQ'D. FASTEN PLATES IN SUCCESSION W/ (2) 3"x0.120" NAILS @ 6" O.C.
 FOR FLUSH BOTTOM BEAMS PROVIDE 2X STACKED PLATES ATOP BEAM AS REQ'D. FASTEN PLATES IN SUCCESSION W/ (2) 3"x0.120" NAILS @ 6" O.C.

GENERAL STRUCTURAL NOTES

FOUNDATION

DESIGN IS BASED ON 2018 NORTH CAROLINA STATE BUILDING CODE, RESIDENTIAL CODE.
 FOOTING DESIGN - 2,000 PSF ALLOWABLE SOIL BEARING PRESSURE IS ASSUMED. BUILDER/CONTRACTOR MUST VERIFY.
 FASTEN 2x4/6 SILL PLATES TO FND WITH A MINIMUM OF 2 ANCHORS PER PLATE, 12" MAX. FROM PLATE ENDS - UTILIZING:
 • 1/2" DIA. ANCHOR BOLTS @ 6'-0" O.C., 7" MIN. EMBEDMENT (CONC), 15" MIN. EMBEDMENT (CMU)
 • SIMPSON MASA ANCHOR STRAPS @ 6'-0" O.C. (CONC)
 • SIMPSON MAB23 ANCHOR STRAPS @ 2'-8" O.C. (CMU)
 (REFER TO DETAILS FOR 10' TALL WALL ANCHOR REQUIREMENTS)

ALL LUMBER EXPOSED TO WEATHER OR IN CONTACT W/ CONCRETE OR CMU SHALL BE PRESERVATIVE TREATED SOUTHERN PINE #2.

BUILDER TO VERIFY CORROSION-RESISTANCE COMPATIBILITY OF HARDWARE & FASTENERS IN CONTACT W/ PRESERVATIVE-TREATED WOOD. CONTACT LUMBER & HARDWARE SUPPLIERS TO COORD.

BASEMENT INTERIOR BEARING WALLS & EXTERIOR WALK-OUT BASEMENT WALLS SHALL BE 2x6 @ 16" O.C. SFF OR 5YP, "STUD" GRADE OR BETTER.

CONCRETE DESIGN BASED ON ACI 318. CONCRETE SHALL ATTAIN THE FOLLOWING MIN. COMPRESSIVE STRENGTHS IN 28 DAYS, UNO.:
 fc = 4,000 psi: FOUNDATION WALLS
 2,500 psi: FOOTINGS & INTERIOR SLABS ON GRADE
 3,000 psi: GARAGE & EXTERIOR SLABS ON GRADE
 fy = 60,000 psi

BASEMENT FOUNDATION WALL DESIGN BASED ON:
 • 9' OR 10' HEIGHT (AS NOTED ON PLANS)
 • TALLER WALLS MUST BE ENGINEERED.
 • NOMINAL WIDTH (1 1/2") FOR 10' THICK WALL.

BASEMENT WALL DESIGN IS BASED ON 60 PCF BACKFILL SOIL TYPE CLASSIFICATIONS (SC, ML-CL, OR CL).

BASEMENT WALLS SHALL BE BRACED, PRIOR TO BACKFILLING, BY ADEQUATE TEMPORARY BRACING OR INSTALL 1st FLOOR DECK.

PROVIDE (2) #5 BARS AROUND ALL SIDES OF OPENINGS IN CONCRETE BSMT. FND. WALL WITH 2" CLEAR. REINFORCEMENT SHALL EXTEND 12" PAST CORNER OF OPENING IN ALL DIRECTIONS.
 FOR OPENINGS UP TO 36", PROVIDE MINIMUM 10" CONCRETE DEPTH OVER OPENING OR (3)2x10 W/ (2)2x6 JACK STUDS, UNO.
 LARGER OPENINGS SHALL BE PER PLAN.

ALL CONCRETE EXPOSED TO THE WEATHER SHALL NOT HAVE LESS THAN 5% OR MORE THAN 1% AIR ENTRAINMENT.

ALL FOOTINGS SHALL BEAR AT LEAST 12" BELOW FINISH GRADE.

PROVIDE (2) #5 BARS AROUND ALL SIDES OF OPENINGS IN CONCRETE BSMT. FND. WALL WITH 2" CLEAR. REINFORCEMENT SHALL EXTEND 12" PAST CORNER OF OPENING IN ALL DIRECTIONS.
 FOR OPENINGS UP TO 36", PROVIDE MINIMUM 10" CONCRETE DEPTH OVER OPENING OR (3)2x10 W/ (2)2x6 JACK STUDS, UNO.
 LARGER OPENINGS SHALL BE PER PLAN.

CONCRETE MASONRY UNITS (CMU) SHALL BE ASTM C40 WITH A MIN. COMPRESSIVE STRENGTH OF 1,900 psi (Fm=1,500 psi). MORTAR SHALL BE ASTM C270, TYPE S. CMU DESIGN PER ACI 530 & 530.1.

CMU FOUNDATION WALLS SHALL HAVE "DUR-O-WALL" HORIZONTAL JOINT REINFORCEMENT (OR EQUAL) - 9 GA. MINIMUM @ 16" O.C.

PROVIDE 2x6 x 16" LONG P.T. PLATE ON TOP OF ALL CRAWL SPACE PIERS. ALL PIERS SHALL BE GROUTED SOLID.

PROVIDE 2x6 P.T. PLATE ON INTERIOR CRAWL SPACE WALLS, FASTENED PER ANCHORAGE SPECIFICATION NOTED ABOVE.

DIMENSIONS BY OTHERS, BUILDER TO VERIFY.

BUILDER TO VERIFY THAT MODEL HAS BEEN ADEQUATELY TREATED BY A LICENSED AND BONDED PEST CONTROL COMPANY FOR SUBTERRANEAN TERMITES. METHOD AND TYPE OF TREATMENT TO BE DETERMINED BY PEST CONTROL COMPANY.

LATERAL BRACING & SHEAR WALL SHEATHING SPECIFICATIONS

THIS MODEL HAS BEEN DESIGNED TO RESIST LATERAL FORCES RESULTING FROM:
 120 MPH WIND IN 2018 NCSBC:RC
 (120 MPH WIND SPEED IN ASCE 7-10 WIND MAP, PER IRC R301.2.1.1) EXP. B, RISK CAT. 2 & SEISMIC CAT. A/B.

THE DESIGN WAS COMPLETED PER 2015 IBC (SECTION 1604) & ASCE 7-10, AS PERMITTED BY R301.3 OF THE 2018 NCSBC:RC, OR THE SIMPLIFIED PRESCRIPTIVE PROCEDURE IN ACCORDANCE WITH THE 2015 IRC IF THE PARAMETERS OF SECTION R602.12 COMPLY. ACCORDINGLY, THIS MODEL, AS DOCUMENTED AND DETAILED HEREIN, IS ADEQUATE TO RESIST THE CODE REQUIRED LATERAL FORCES.

DESIGN WIND UPLIFT LOADS HAVE BEEN CALCULATED UTILIZING ASCE 7-10 (ACCEPTED ENGINEERING PRACTICE) AS ALLOWED PER 2018 NCSBC:RC SECTION R802.11.1.1. THIS MODEL HAS BEEN DETAILED WHERE REQUIRED & ENGINEERED TO RESIST THE WIND UPLIFT LOAD PATH PER SECTIONS R602.3.5 & R802.11.

EXT. WALL SHEATHING SPECIFICATION

7/16" OSB OR 1/2" PLYWOOD:
 FASTEN SHEATHING W/ 2 3/8"x0.113" NAILS @ 6" O.C. AT EDGES & @ 12" O.C. IN THE PANEL FIELD. TYP. UNO.

HORIZONTAL BLOCKING OF EXT. WALL/SHEAR WALL PANEL EDGES IS NOT REQUIRED BY THIS DESIGN EXCEPT FOR THOSE AREAS SPECIFICALLY NOTED.

ALL EXT. WALLS SHALL BE CONTINUOUSLY SHEATHED AND ARE CONSIDERED SHEAR WALLS.

ALT. STAPLE CONNECTION SPEC: 1 1/2" 16 GA STAPLES (1/8" CROWN) @ 3" O.C. AT EDGES & @ 6" O.C. IN FIELD.

BLOCKED PANEL EDGES

AT DESIGNATED AREAS - FASTEN SHEATHING W/ 2 3/8" x 0.113" NAILS @ 6" O.C. AT ALL PANEL EDGES AND 12" O.C. IN THE PANEL FIELD OR 1 3/4" 16 GA STAPLES (1/8" CROWN) @ 3" O.C. AT EDGES & @ 6" O.C. IN FIELD. ALL SHEATHING PANELS SHALL BE ORIENTED AND INSTALLED FULL HEIGHT OF SHEAR WALL OR 2x HORIZONTAL BLOCKING SHALL BE PROVIDED TO SUPPORT UNSUPPORTED PANEL EDGES & EDGE FASTENINGS.

3" O.C. EDGE NAILING

AT DESIGNATED AREAS - FASTEN PANEL EDGES OF WOOD STRUCTURAL WALL SHEATHING TO FRAMING W/ 8d NAILS @ 3" O.C. NO STAPLE ALTERNATIVE AVAILABLE AT THIS SPEC. ALL SHEATHING PANELS SHALL BE ORIENTED AND INSTALLED FULL HEIGHT OF SHEAR WALL OR 2x HORIZONTAL BLOCKING SHALL BE PROVIDED TO SUPPORT UNSUPPORTED PANEL EDGES AND 3" O.C. EDGE FASTENINGS.

NOTES

SEE CONNECTION SPECIFICATIONS CHART FOR STANDARD SHEAR TRANSFER DETAILING. IF ADDITIONAL CAPACITY IS REQUIRED BY DESIGN, IT WILL BE SPECIFICALLY NOTED ON PLAN.

DESIGN ASSUMES 16" O.C. MAX. STUD SPACING, UNO.

ALL STRUCTURAL PANELS ARE TO BE DIRECTLY APPLIED TO STUD FRAMING.

PRE-MANUFACTURED PANELIZED WALLS: FASTEN TOGETHER END STUDS OF WALL PANELS SHEATHED W/ OSB OR PLYWOOD W/ 3" x 0.120" NAILS @ 4" O.C. (THRU ONE SIDE ONLY)

INDICATES EXTENT OF INT. OSB SHEARWALL OR 3" O.C. OSB SHEARWALL.

INDICATES HOLD-DOWN BELOW

FLOOR FRAMING

I-JOISTS/TRUSSES SHALL BE DESIGNED BY MANUF. TO MEET OR EXCEED L/480 LIVE LOAD DEFLECTION CRITERIA. (EXCLUDES MARBLE FLOORS - CONTACT MKK FOR MARBLE FLOOR DESIGNS)

AT I-JOIST FLOORS, PROVIDE 1 1/8" MIN. OSB RIM BOARD.

METAL HANGERS SHALL BE SPECIFIED BY MANUFACTURER, UNO.

FLOOR SHEATHING SHALL BE 23/32" A.P.A. RATED "STUD-1-FLOOR" 24" O.C. EXPOSURE 1 (OR APPROVED EQUAL) WITH TONGUE AND GROOVE EDGES. FASTEN TO FRAMING MEMBERS W/ GLUE AND
 - 2 1/2" x 0.131" NAILS @ 6" O.C. @ PANEL EDGES & @ 12" O.C. FIELD.
 - 2 3/8" x 0.120" NAILS @ 4" O.C. @ PANEL EDGES & @ 8" O.C. FIELD.
 - 2 3/8" x 0.113" NAILS @ 3" O.C. @ PANEL EDGES & @ 6" O.C. IN FIELD.
 - * @ 2" MIN. SCREWS @ 6" O.C. @ PANEL EDGES & @ 12" O.C. FIELD.

ROOF FRAMING

BAY WINDOWS & SHED ROOFS (UP TO 6' SPAN) CAN BE 2x4 OR 2x6 RAFTERS & CEILING JOISTS @ 16/24" O.C.

FASTEN EACH ROOF TRUSS TO TOP PLATE W/ SIMPSON H25T CLIP (OR APPROVED EQUAL) @ ALL BEARING POINTS. PROVIDE (2) H25T CLIPS AT 2-PLY GIRDER TRUSSES, (3) H25T CLIPS AT 3-PLY GIRDER TRUSSES & ROOF BEAMS - AT ALL BEARING POINTS.

METAL HANGERS SHALL BE SPECIFIED BY THE MANUFACTURER, UNO.

ERECT AND INSTALL ROOF TRUSSES PER WTGA & TPI'S BC51 I-08 "GUIDE TO GOOD PRACTICE FOR HANDLING, INSTALLING & BRACING OF METAL PLATE CONNECTED WOOD TRUSSES."

SUPPORT PORCH & SHORT SPAN ROOF TRUSSES (MAX T' SPAN) W/ 2x4 LEDGER FASTENED TO:
 - RIM BOARD W/ (2) 3"x0.131" NAILS @ 16" O.C. MAX. (I-JOISTS)
 - TRUSS VERTICALS W/ (3) 3"x0.131" NAILS @ 19.2" O.C. MAX. (FLOOR TRUSSES)

ROOF SHEATHING SHALL BE 7/16" A.P.A. RATED SHEATHING 24/16 EXPOSURE 1 (OR APPROVED EQUAL). FASTEN TO FRAMING MEMBERS
 - W/ 2 1/2" x 0.131" NAILS @ 6" O.C. @ PANEL EDGES & @ 12" O.C. FIELD.
 - W/ 2 3/8" x 0.120" NAILS @ 4" O.C. @ PANEL EDGES & @ 8" O.C. FIELD.
 - W/ 2 3/8" x 0.113" NAILS @ 3" O.C. @ PANEL EDGES & @ 6" O.C. FIELD.

HOLD-DOWN SCHEDULE

SYMBOL	SPECIFICATION
HD-1	SIMPSON HTT4 HOLD-DOWN *
HD-2	SIMPSON M5TC66 STRAP TIE (CENTER STRAP ON FLOOR SYSTEM UNO.) (PRE-BENT M5TC66 ALT. WHEN SPECIFIED)
HD-3	SIMPSON 5THD14/14RJ HOLD-DOWN

ALTERNATIVE TO 56T24 ANCHOR BOLT SPECIFICATION:
 * UTILIZE SIMPSON "SET" EPOXY SYSTEM TO FASTEN 3/8" DIA. THREADED ROD INTO CONCRETE FOUNDATION. PROVIDE 12" MIN. EMBEDMENT INTO CONCRETE. INSTALL PER MANUF. RECOMMENDATIONS. DO NOT LOCATE ANCHORS WITHIN 1 3/4" OF EDGE OF FOUNDATION.

LEGEND

- INTERIOR BEARING WALL
- BEARING WALL ABOVE
- BEAM / HEADER
- INDICATES SHEAR WALL & EXTENT
- EXTENT OF OVERFRAMING
- METAL HANGER
- INDICATES POST ABOVE. PROVIDE SOLID BLOCKING UNDER POST OR JAMB ABOVE.
- INDICATES HOLD-DOWN OR STRAP. REFER TO SCHEDULE.

GENERAL STRUCTURAL NOTES

DESIGN IS BASED ON 2018 NORTH CAROLINA STATE BUILDING CODE, RESIDENTIAL CODE.
 WOOD FRAME ENGINEERING IS BASED ON NDS, "NATIONAL DESIGN SPECIFICATION FOR WOOD CONSTRUCTION" - LATEST EDITION.

DESIGN LOADS:
 ROOF: DEAD = 7 PSF T.C., 10 PSF B.C., LIVE = 16 PSF, LOAD DURATION FACTOR = 1.25
 FLOOR: LIVE = 40 PSF (30 PSF @ SLEEPING AREAS) DEAD = 10 PSF (I-JOISTS & SOLID SAMN) 10 PSF T.C., 5 PSF B.C. (TRUSSES) (ADD'L 10 PSF @ TILE)
 LATERAL 120 MPH, EXPOSURE B. SEISMIC A/B.
 SOIL 2,000 PSF ASSUMED ALLOWABLE BEARING PRESSURE (TO BE VERIFIED BY BUILDER)

GENERAL FRAMING

ALL TYP. NAIL FASTENER REQUIREMENTS ARE NOTED IN STANDARD CONNECTIONS TABLE OR ON PLANS. ALL NAILS SPECIFIED ARE MIN DIAMETER AND LENGTH REQUIRED FOR CONNECTION. ALL HANGER NAILS SHALL BE INSTALLED PER MANUFACTURER'S REQUIREMENTS FOR MAX CHARTED CAPACITY. NOTE: HANGERS USE COMMON NAIL DIAMETERS NOT TYPICAL FRAMING GUN NAILS.

REFER TO FASTENING SCHEDULE TABLE R602.3(1) FOR ALL CONNECTIONS, TYP. UNO.

EXT. & INT. BRG WALLS SHALL BE 2x4 OR 2x6 (AS SHOWN ON PLANS) @ 16" O.C. SFF OR 5YP "STUD" GRADE LUMBER, OR BETTER, UNO.
 WALLS OVER 12' TALL SHALL BE PER PLAN.

ALL HEADERS, BEAMS & OTHER STRUCTURAL MEMBERS SHALL BE SPRUCE-PINE-FIR #2 (SFF) OR SOUTHERN PINE #2 (5YP) LUMBER, OR BETTER (KILN-DRIED). ALL HEADERS HAVE BEEN DESIGNED BASED ON CALCULATED LOADS & SIZED ACCORDINGLY. CODE TABLES HAVE NOT BEEN USED.

ALL NON-BEARING INTERIOR STUD WALLS SHALL BE CONSTRUCTED WITH 2x "STUD" GRADE MEMBERS SPACED @ 16" O.C. (MAX. UNO.)
 HEADERS IN NON-LOAD BEARING WALLS SHALL BE:
 (1)2x4/6 FLAT @ OPENINGS UP TO 4', (2)2x4/6 FLAT UP TO 8',

ALL FRAMING LUMBER SHALL BE DRIED TO 15% MC (KD-15).

ENGINEERED LUMBER BEAMS TO MEET OR EXCEED THE FOLLOWING:
 • LVL' - Fb=2325 psi, Fv=310 psi, E=1.55x10^6 psi
 • LVL' - Fb=2600 psi, Fv=285 psi, E=2.20x10^6 psi
 • PSL' - Fb=2400 psi, Fv=240 psi, E=2.0x10^6 psi

M&K SHALL BE FULLY INDEMNIFIED FOR ANY AND ALL ISSUES RESULTING FROM OR RELATED TO ANY BUILDING COMPONENT IF THE OWNER DOES NOT SUBMIT THE COMPONENT SHOP DRAWINGS TO MKK FOR STRUCTURAL REVIEW PRIOR TO FABRICATION, DELIVERY, OR INSTALLATION.

FOR 2 & 3 PLY BEAMS OF EQUAL WIDTH, FASTEN PLIES TOGETHER WITH 3 ROWS OF 3"x0.120" NAILS @ 6" O.C. OR 2 ROWS 1/4"x3/8" SIMPSON SDS SCREWS (OR 3/8" TRUSSLOK SCREWS) @ 16" O.C. USE A MINIMUM OF 3 ROWS FOR BEAM DEPTHS OF 14" OR GREATER. APPLY FASTENING AT BOTH FACES FOR 3-PLY CONDITION. LOCATE TOP & BOTTOM NAILS/SCREWS 2" FROM EDGE. SOLID 3/4" OR 5/4" BEAMS ARE ACCEPTABLE. USE 2 ROWS OF NAILS FOR 2x6 & 2x8 MEMBERS.

FOR 4 PLY BEAMS OF EQUAL WIDTH, FASTEN PLIES TOGETHER WITH 3 ROWS OF 1/4"x6" SIMPSON SDS SCREWS (OR 6 3/4" TRUSSLOK SCREWS) @ 16" O.C. USE A MINIMUM OF 4 ROWS FOR BEAM DEPTHS OF 14" OR GREATER. APPLY FASTENING AT BOTH FACES (ONE SIDE ONLY FOR TRUSSLOK SCREWS). LOCATE TOP AND BOTTOM SCREWS 2" FROM EDGE. A SOLID T' BEAM IS ACCEPTABLE.

ALL HEADERS SHALL BE SUPPORTED BY (1)2x JACK STUD & (1)2x KING STUD, MINIMUM.
 - THE NUMBER OF STUDS SPECIFIED AT A SUPPORT INDICATES THE NUMBER OF JACK STUDS REQUIRED, UNO.

ALL MULTI-PLY STUDS TO BE FASTENED TOGETHER W/ 3"x0.131" NAILS @ 24" O.C. (MIN), EACH PLY.

PROVIDE SOLID BLOCKING IN FLOOR SYSTEM UNDER ALL POSTS CONTINUOUS TO FND/BEARING. BLOCKING TO MATCH POST ABOVE.

FASTEN 2x WOOD PLATES TO TOP FLANGE OF STEEL BEAMS WITH P.A.F.'s (HILT' X-CF PINS OR EQUAL) @ 16" O.C. STAGGERED, OR 1/2" DIA. BOLTS @ 48" O.C. STAGGERED.

ALL EXTERIOR 4x4 WOOD POSTS SHALL HAVE SIMPSON BC52-2/4 GAP & ABW44Z BASE, UNO.

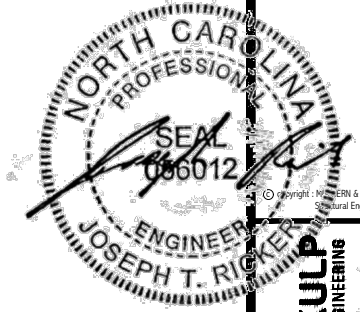

MULHERN+KULP
RESIDENTIAL STRUCTURAL ENGINEERING
300 Duneside Ave., Building 4 - Asheville, PA 19822
P: 215-598-8281 - mulhern+kulp.com
NC LICENSE #C-3825

M&K project number:
126-23047
project mgr: JTR
drawn by: JAD
issue date: 01-27-24

REVISIONS:

date:	initial:



FOUNDATION PLANS
HONEYCUTT HILLS
LOT 29 - DRAYTON 3
RALEIGH, NC

sheet:
S1.0

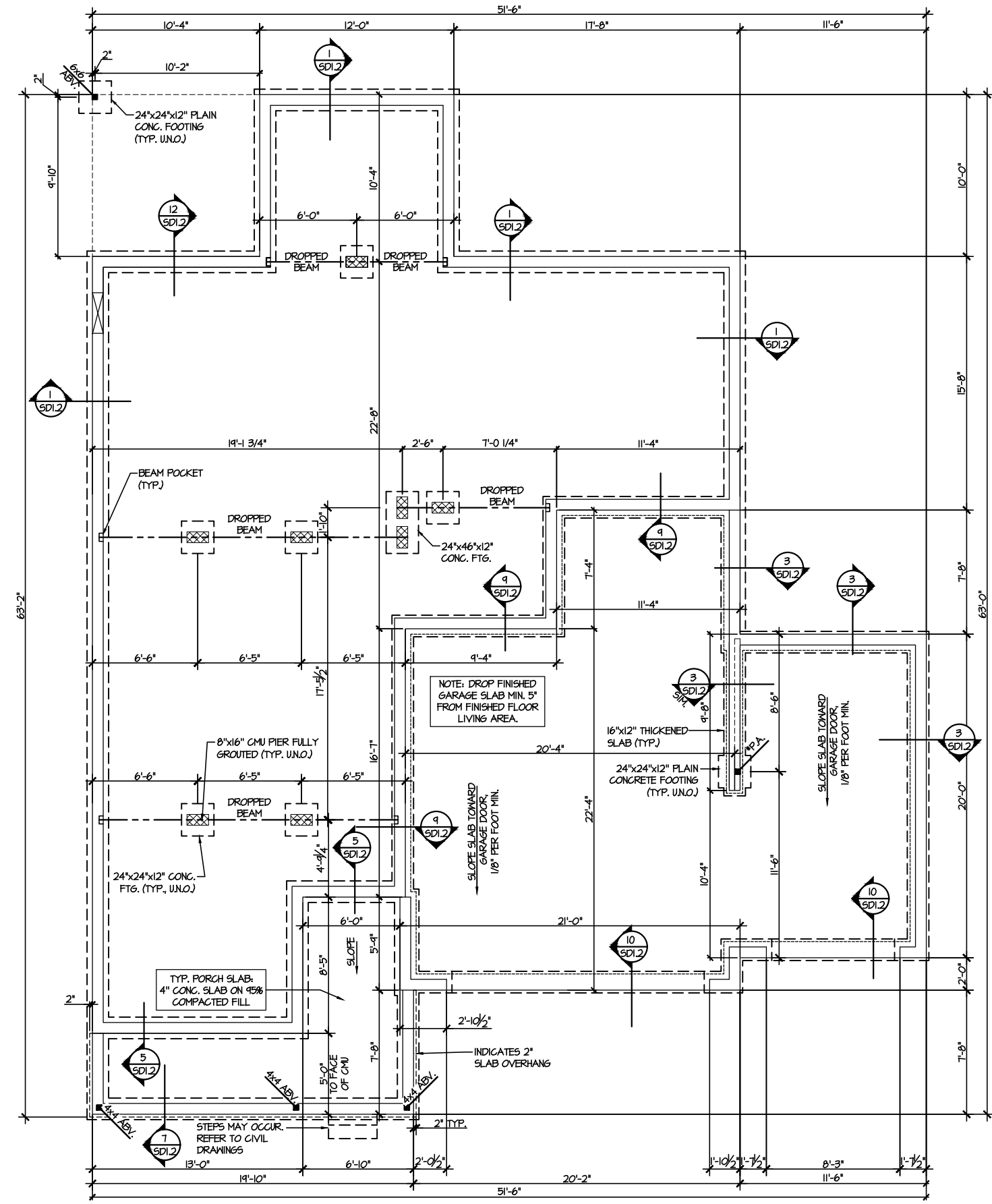

1 CRAWL SPACE FOUNDATION PLAN
SCALE: 1/8"=1'-0"

LEGEND	
	INTERIOR BEARING WALL
	BEARING WALL ABOVE
	BEAM / HEADER
	INDICATES SHEAR WALL & EXTENT
	EXTENT OF OVERFRAMING
	JL METAL HANGER
	INDICATES POST ABOVE. PROVIDE SOLID BLOCKING UNDER POST OR JAMB ABOVE.
	INDICATES HOLD-DOWN OR STRAP. REFER TO SCHEDULE.

REFER TO SO.O FOR TYPICAL STRUCTURAL NOTES & SCHEDULES

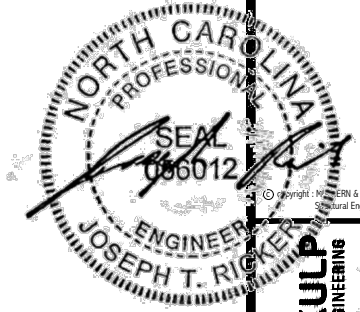

MULHERN+KULP
RESIDENTIAL STRUCTURAL ENGINEERING
300 Duneside Ave, Building 4 - Asheville, PA 19802
P 725-948-8281 - mulhern+kulp.com
NC LICENSE #C-3825



M&K project number:
126-23047
project mgr: JTR
drawn by: JAD
issue date: 01-27-24

REVISIONS:
date: initial:

DRB
HOMES

FLOOR FRAMING PLANS
HONEYCUTT HILLS
LOT 29 - DRAYTON 3
RALEIGH, NC

sheet:
S2.0

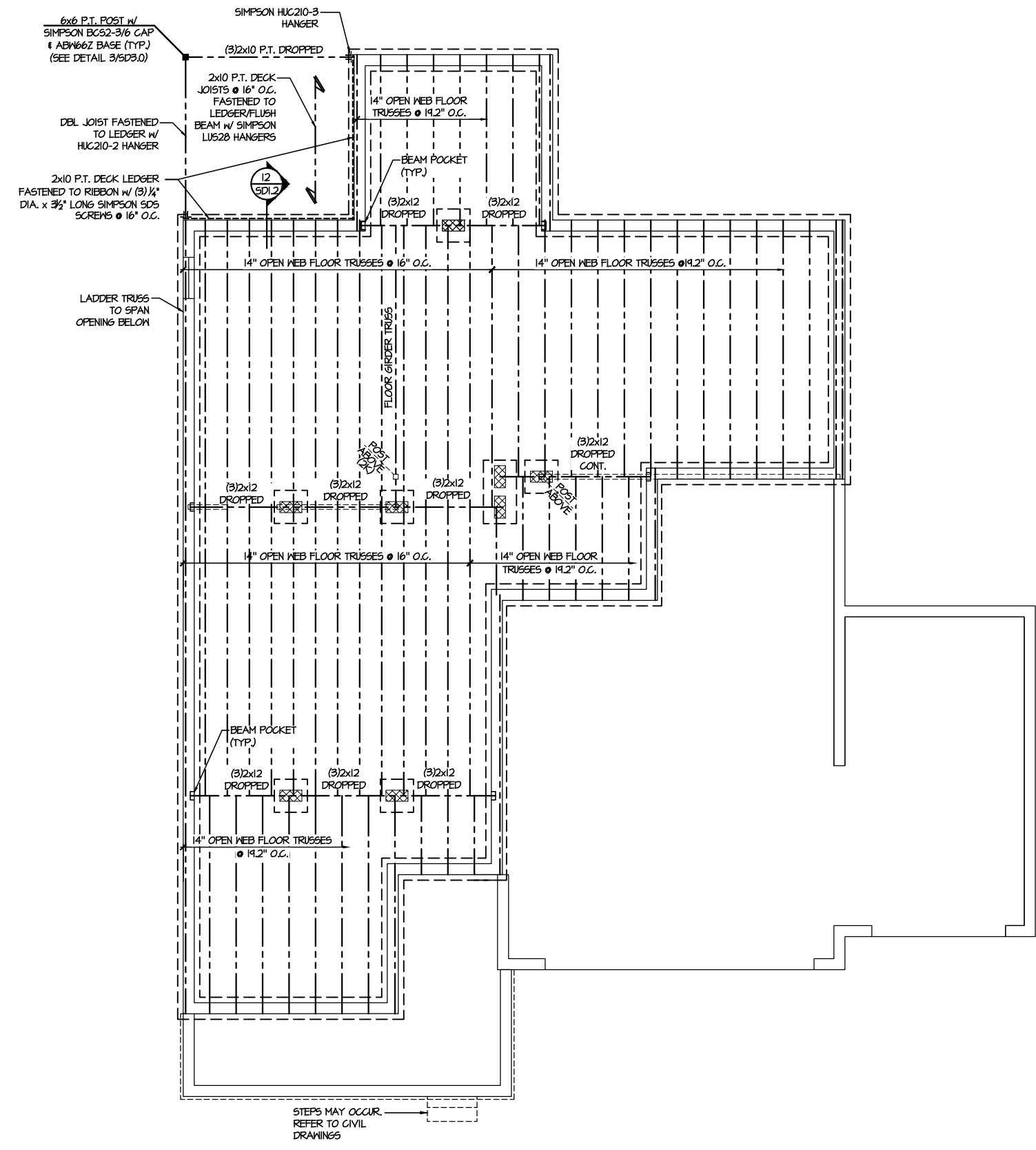

1 1ST FLOOR FRAMING PLAN - CRAWL SPACE
SCALE: 1/8"=1'-0"

SD2.I REFERS TO SD2.IA FOR LVL/PSL/LSL BEAMS OR SD2.IB FOR FLITCH BEAMS OR SD2.IC FOR STEEL BEAMS

LEGEND	
	INTERIOR BEARING WALL
	BEARING WALL ABOVE
	BEAM / HEADER
	INDICATES SHEAR WALL & EXTENT
	EXTENT OF OVERFRAMING
	JL METAL HANGER
	* INDICATES POST ABOVE. PROVIDE SOLID BLOCKING UNDER POST OR JAMB ABOVE.
	▷ INDICATES HOLD-DOWN OR STRAP. REFER TO SCHEDULE.

REFER TO S.O.O FOR TYPICAL STRUCTURAL NOTES & SCHEDULES

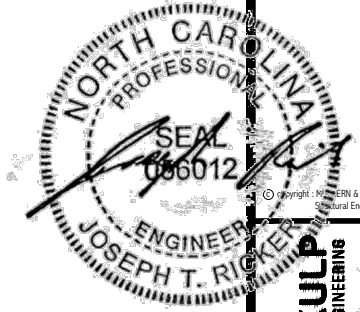

M&K project number:
126-23047
project mgr: JTR
drawn by: JAD
issue date: 01-27-24

REVISIONS:
date: initial:



FLOOR FRAMING PLANS
HONEYCUTT HILLS
LOT 29 - DRAYTON 3
RALEIGH, NC

sheet:
S3.0

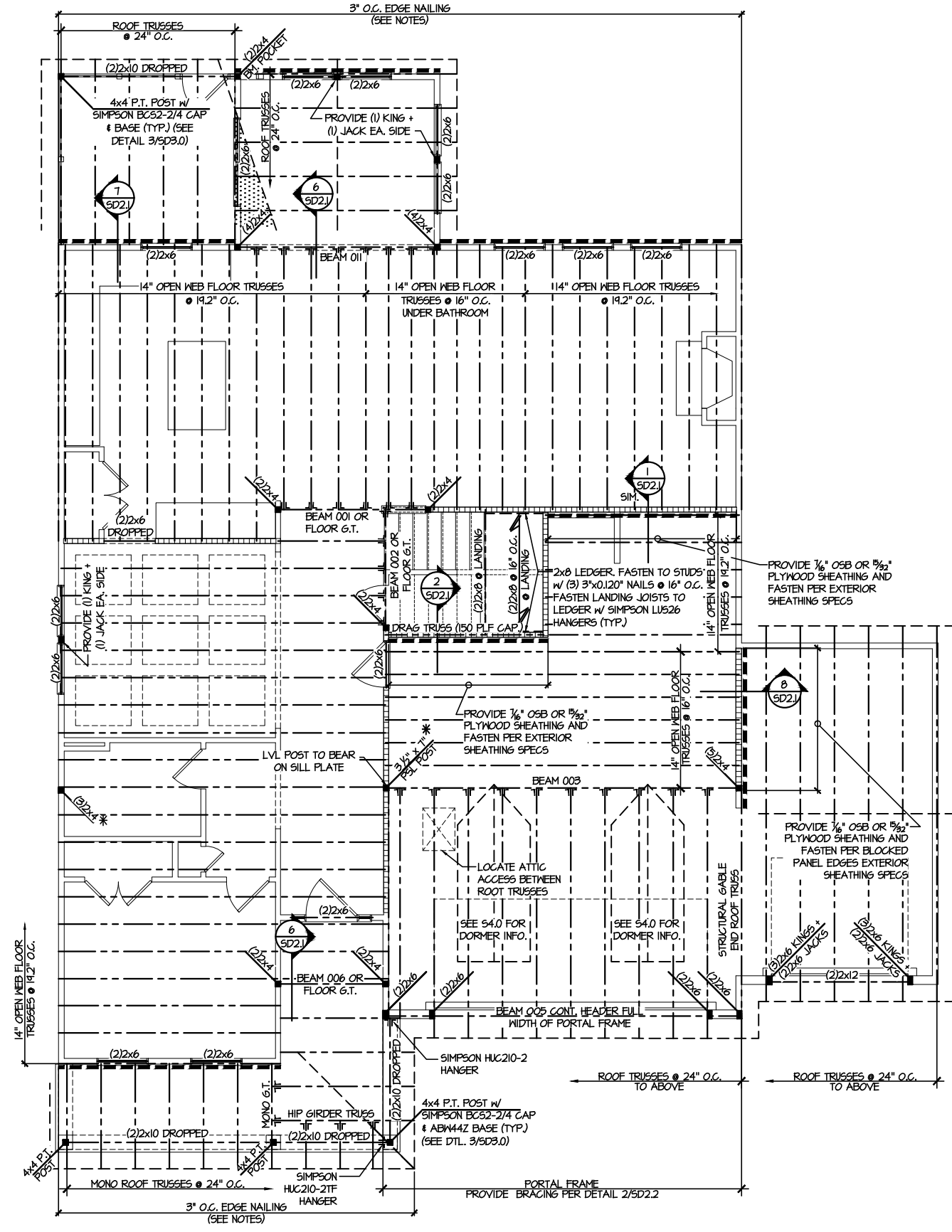

1 2ND FLOOR FRAMING PLAN
SCALE: 1/8"=1'-0"

ENGINEERED BEAM MATERIAL SCHEDULE

BEAM NUMBER	LVL OPTION	PSL OPTION	LSL OPTION	FLITCH OPTION	STEEL OPTION
001	(2)3"x14" - F	3"x14" - F	(2)3"x14" - F	(2)2x12 + (1)1/2"x11/4" STEEL FLITCH PLATES - FB	M12x14 - F
002	(2)3"x14" - F	3"x14" - F	(2)3"x14" - F	(2)2x12 + (1)1/2"x11/4" STEEL FLITCH PLATES - FB	M12x14 - F
003	(3)1 1/2"x18" - FB or (2)3/4"x20" - FB	3/4"x18" - FB	N/A	(3)2x12 + (2) 3/4"x11/4" STEEL FLITCH PLATES - FB	M12x26 - F
004	(2)3"x14" - F	3"x14" - F	(2)3"x14" - F	(2)2x12 + (1)1/2"x11/4" STEEL FLITCH PLATES - FB	M12x14 - F
005	(2)3"x11 1/2" - H cont.	3"x11 1/2" - H cont.	(2)3"x11 1/2" - H cont.	(3)2x12 + (2) 1/2"x11/4" STEEL FLITCH PLATES - H cont.	N/A
005A	(3)3/4"x14" - H cont.	3/4"x14" - H cont.	N/A	(3)2x12 + (2) 1/2"x11/4" STEEL FLITCH PLATES - H cont.	N/A
006	(1)3"x14" - F	3"x14" - F	(2)3"x14" - F	(2)2x12 + (1)1/2"x11/4" STEEL FLITCH PLATES - FB	M12x14 - F
007	(2)3"x11 1/2" - D	3"x11 1/2" - D	(2)3"x11 1/2" - D	(2)2x12 + (1)1/2"x11/4" STEEL FLITCH PLATES - H cont.	M10x12 - D
008	(2)3"x16" - H cont.	3"x16" - H cont.	(3)3"x16" - H cont.	(3)2x12 + (2) 1/2"x11/4" STEEL FLITCH PLATES - H cont.	N/A
009	(2)3"x9" - F	3"x9" - F	(2)3"x9" - F	(2)2x10 + (1)1/2"x9" STEEL FLITCH PLATES - F	M8x10 - F
010	(2)3"x14" - F	3"x14" - F	(2)3"x14" - F	(2)2x12 + (1)1/2"x11/4" STEEL FLITCH PLATES - FB	M12x14 - F
011	(2)3"x14" - F	3"x14" - F	(2)3"x14" - F	(2)2x12 + (1)1/2"x11/4" STEEL FLITCH PLATES - FB	M12x14 - F
012	(2)3"x11 1/2" - D	3"x11 1/2" - D	(2)3"x11 1/2" - D	(2)2x12 + (1)1/2"x11/4" STEEL FLITCH PLATES - D	M10x12 - D

LEGEND

- ▬ INTERIOR BEARING WALL
- - - BEARING WALL ABOVE
- ▬ BEAM / HEADER
- ▬ INDICATES SHEAR WALL & EXTENT
- ▬ EXTENT OF OVERFRAMING
- ⊥ L METAL HANGER
- INDICATES POST ABOVE. PROVIDE SOLID BLOCKING UNDER POST OR JAMB ABOVE.
- ▶ INDICATES HOLD-DOWN OR STRAP. REFER TO SCHEDULE.

REFER TO 50.0 FOR TYPICAL STRUCTURAL NOTES & SCHEDULES

SD2.1 REFERS TO SD2.1A FOR LVL/PSL/LSL BEAMS OR SD2.1B FOR FLITCH BEAMS OR SD2.1C FOR STEEL BEAMS

- BEAM NOTATION:
 - "F" INDICATES FLUSH BEAM
 - "FT" INDICATES FLUSH TOP BEAM
 - "FB" INDICATES FLUSH BOTTOM BEAM
 - "D" INDICATES DROPPED BEAM
 - "H" INDICATES DROPPED OPENING HEADER
- REFER TO DETAIL D/SD2.0 FOR TYPICAL FLITCH BEAM CONNECTIONS
- REFER TO DETAIL E/SD2.0 FOR TYPICAL STEEL BEAM CONNECTIONS
- FOR FLUSH TOP BEAMS PROVIDE 2X STACKED PLATES BENEATH BEAM AS REQ'D. FASTEN PLATES IN SUCCESSION w/ (2) 3"x0.120" NAILS @ 8" O.C.
- FOR FLUSH BOTTOM BEAMS PROVIDE 2X STACKED PLATES ATOP BEAM AS REQ'D. FASTEN PLATES IN SUCCESSION w/ (2) 3"x0.120" NAILS @ 8" O.C.

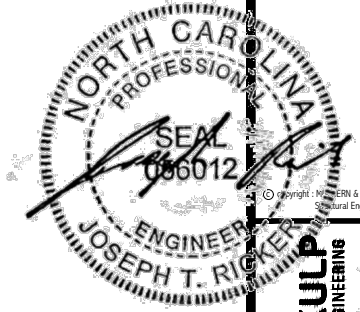

MULHERN+KULP
RESIDENTIAL STRUCTURAL ENGINEERING
308 Duneside Ave, Building 4 - Anahim, PA 19022
P 215-998-5281 - mulhern+kulp.com
NC LICENSE #C-3825



M&K project number:
126-23047
project mgr: JTR
drawn by: JAD
issue date: 01-27-24

REVISIONS:
date: initial:



ROOF FRAMING PLANS
HONEYCUTT HILLS
LOT 29 - DRAYTON 3
RALEIGH, NC

sheet:
S4.0

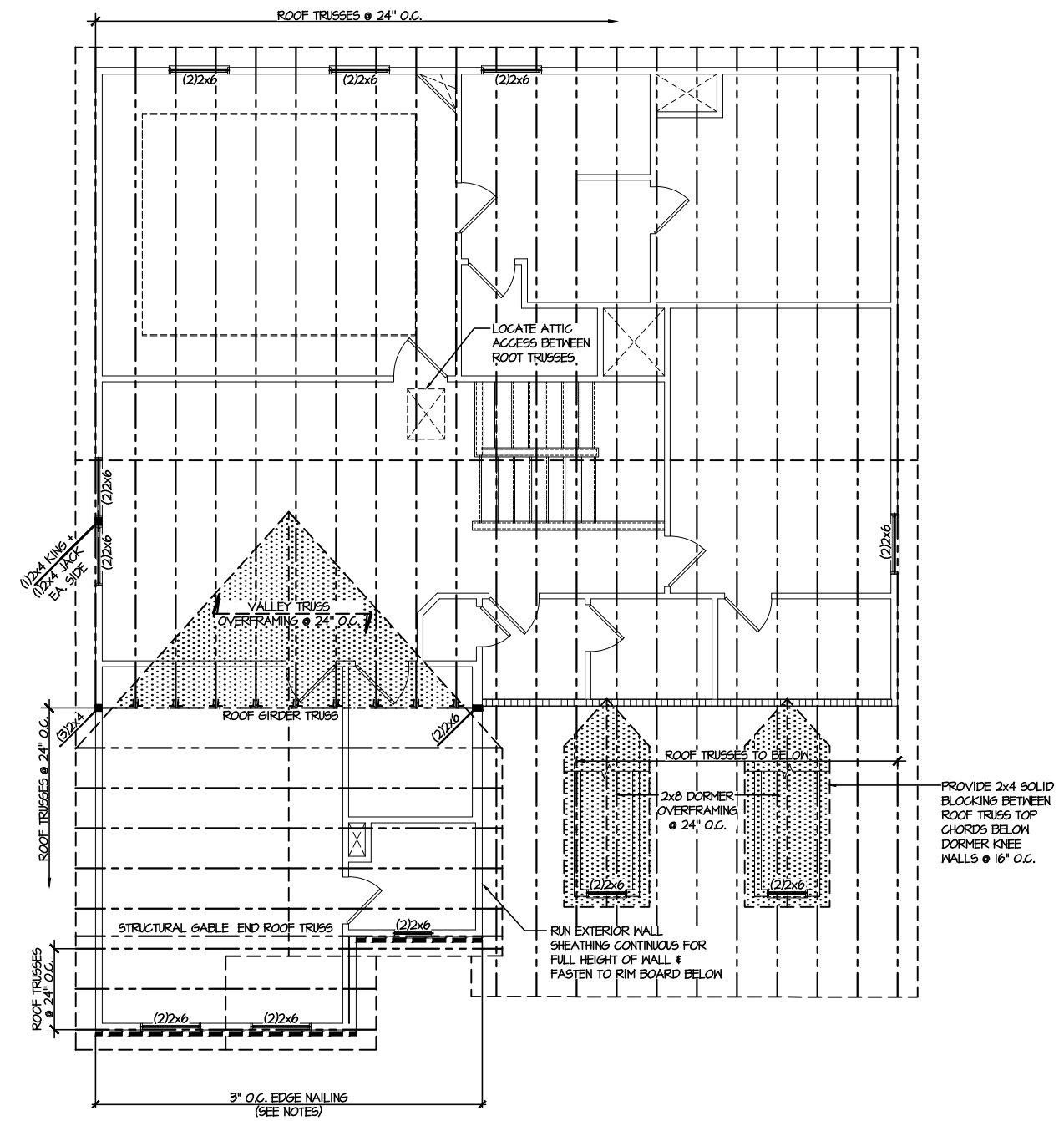

1 ROOF FRAMING PLAN
SCALE: 1/8"=1'-0"

LEGEND	
	INTERIOR BEARING WALL
	BEARING WALL ABOVE
	BEAM / HEADER
	INDICATES SHEAR WALL & EXTENT
	EXTENT OF OVERFRAMING
	M METAL HANGER
	INDICATES POST ABOVE. PROVIDE SOLID BLOCKING UNDER POST OR JAMB ABOVE.
	INDICATES HOLD-DOWN OR STRAP. REFER TO SCHEDULE.

REFER TO S.O. FOR
TYPICAL STRUCTURAL NOTES
& SCHEDULES

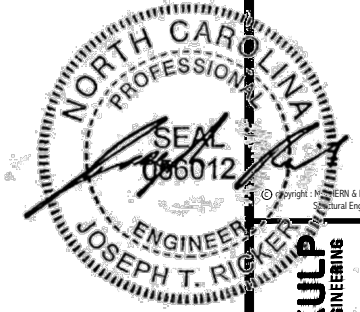

MULHERN+KULP
RESIDENTIAL STRUCTURAL ENGINEERING
300 Duneside Ave., Building 4 - Asheville, PA 18002
P: 717-698-0000 • m+k@mulhernkulp.com
NC LICENSE #C-3825



M&K project number:
126-23047
project mgr: **JTR**
drawn by: **JAD**
issue date: **01-27-24**

REVISIONS:
date: initial:

DRB
HOMES

FOUNDATION DETAILS
HONEYCUTT HILLS
LOT 29 - DRAYTON 3
RALEIGH, NC

sheet:
SD1.2

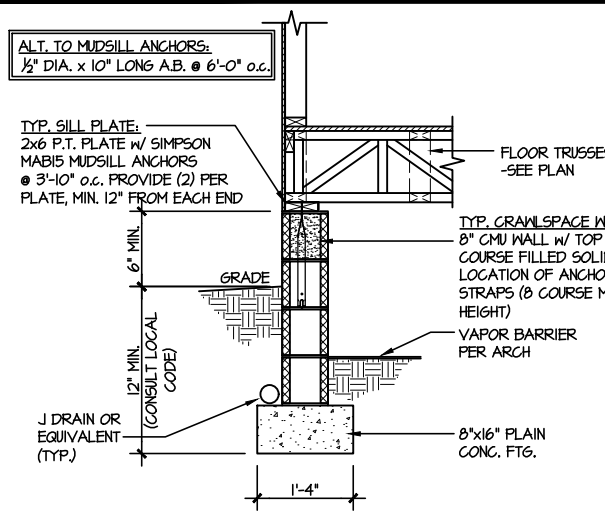

1 TYPICAL CRAWLSPACE FOUNDATION
SCALE: 3/8"=1'-0"

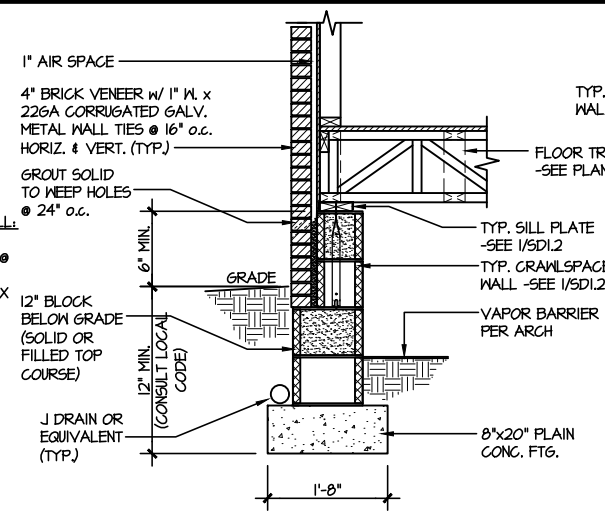

2 TYPICAL CRAWLSPACE FOUNDATION
SCALE: 3/8"=1'-0" w/ BRICK VENEER

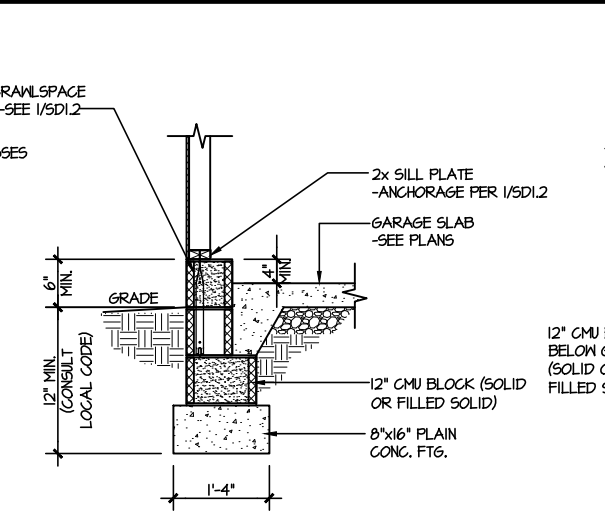

3 TYPICAL GARAGE FOUNDATION
SCALE: 3/8"=1'-0"

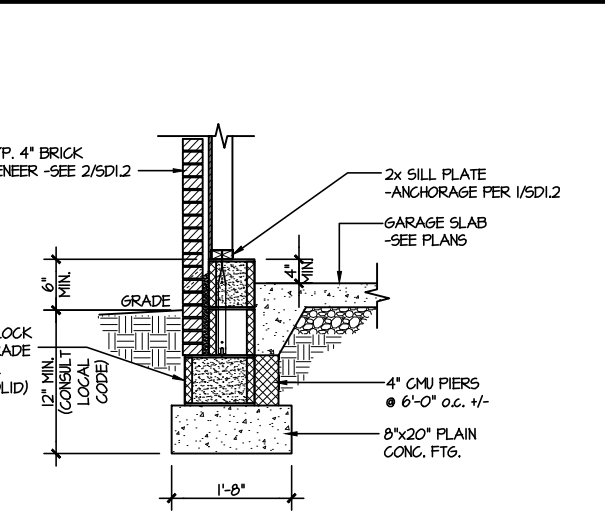

4 TYPICAL GARAGE FOUNDATION
SCALE: 3/8"=1'-0" w/ BRICK VENEER

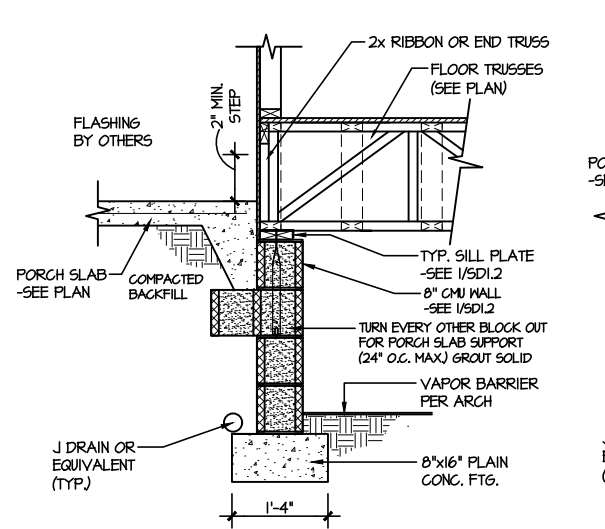

5 TYPICAL CRAWLSPACE FOUNDATION @ PORCH/PATIO SLAB
SCALE: 3/8"=1'-0"
(REFER TO DETAIL 12 FOR WOOD PORCH OPTION)

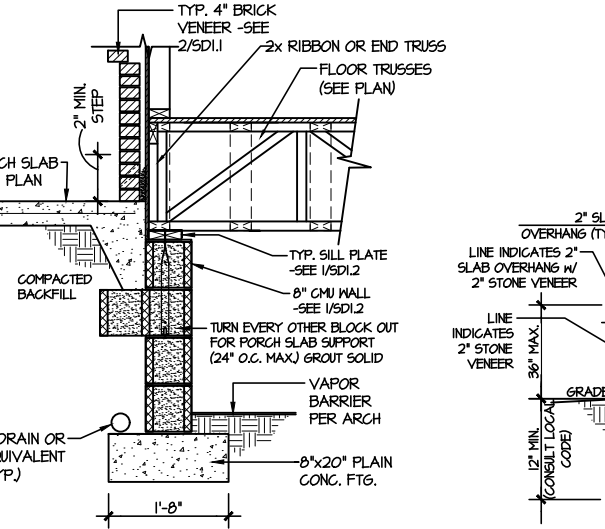

6 TYPICAL CRAWLSPACE FOUNDATION @ PORCH/PATIO SLAB
SCALE: 3/8"=1'-0" w/ BRICK VENEER

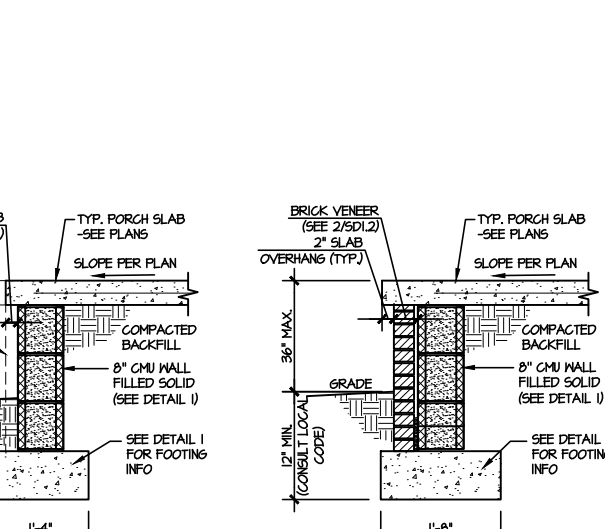

7A TYP. FOOTINGS @ PORCH SLAB
SCALE: 3/8"=1'-0"

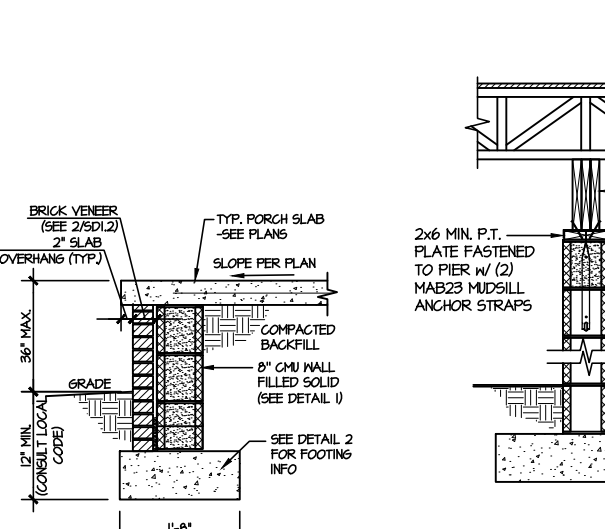

7B TYP. FOOTINGS @ PORCH SLAB
SCALE: 3/8"=1'-0" w/ BRICK VENEER

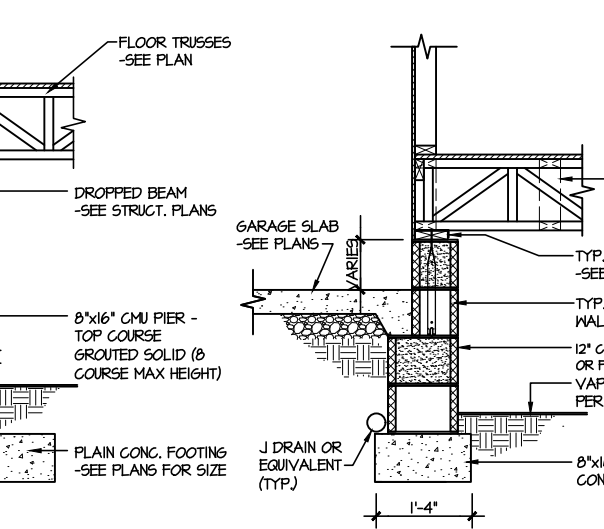

8 TYPICAL CRAWLSPACE FND. @ INTERIOR PIER
SCALE: 3/8"=1'-0"

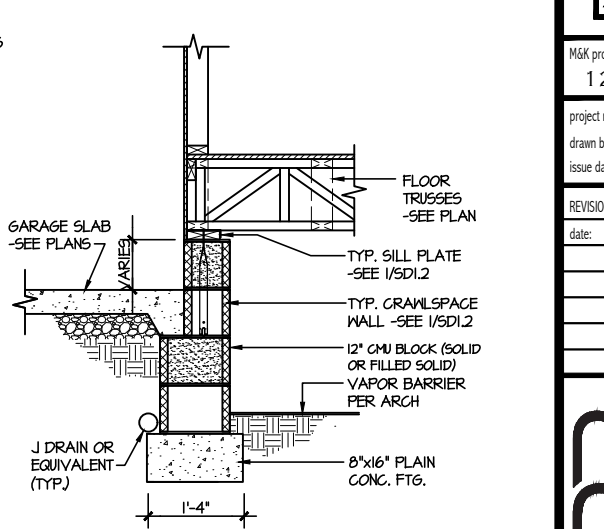

9 TYPICAL CRAWLSPACE FOUNDATION @ GARAGE
SCALE: 3/8"=1'-0"

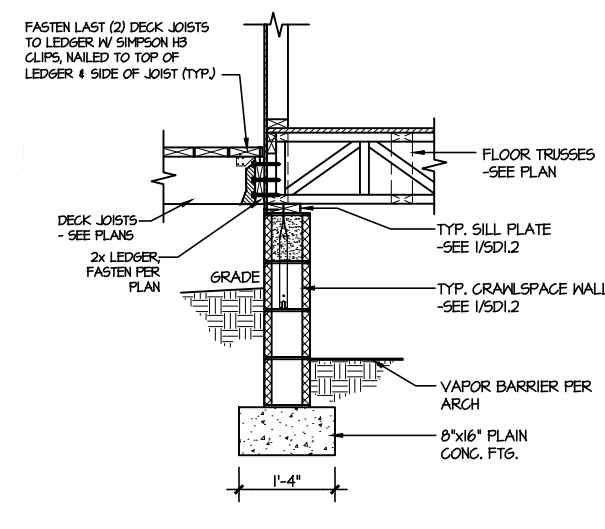

12 TYPICAL CRAWLSPACE FOUNDATION @ WOOD PORCH/DECK
SCALE: 3/8"=1'-0"

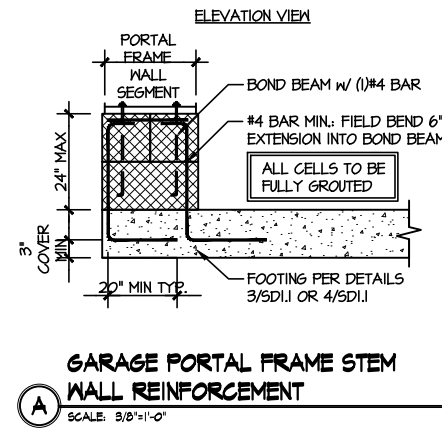

A GARAGE PORTAL FRAME STEM WALL REINFORCEMENT
SCALE: 3/8"=1'-0"

LETTERED DETAILS ARE TYPICAL FOR THIS HOME & SHALL BE IMPLEMENTED IN ALL APPLICABLE AREAS. THESE DETAILS ARE NOT "CUT" ON THE PLANS.

NUMBERED DETAILS ARE PLAN SPECIFIC AND ARE ONLY REQUIRED WHERE SPECIFICALLY INDICATED ("CUT") ON THE PLANS.

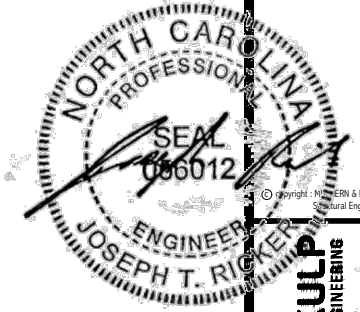

MULHERN+KULP
RESIDENTIAL STRUCTURAL ENGINEERING
300 Duneside Ave. Building 4 - Anahim, PA 15082
P: 724-698-0000 • mulhern+kulp.com
NC LICENSE #C-3825



M&K project number:
126-23047
project mgr: **JTR**
drawn by: **JAD**
issue date: **01-27-24**

REVISIONS:
date: _____ initial: _____

DRB HOMES

FRAMING DETAILS
HONEYCUTT HILLS
LOT 29 - DRAYTON 3
RALEIGH, NC

sheet:
SD2.0

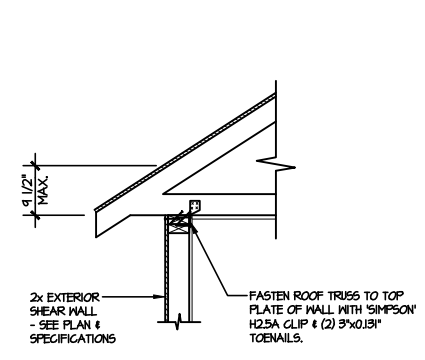

(A1) TYPICAL SHEAR TRANSFER DETAIL @ ROOF
SCALE: 3/8"=1'-0"
HEEL HEIGHT LESS THAN 1 1/2'
NO BLOCKING REQ'D

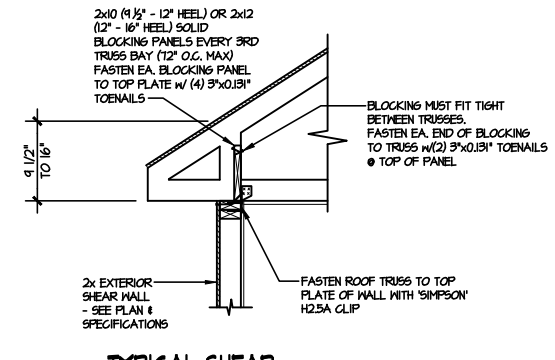

(A2) TYPICAL SHEAR TRANSFER DETAIL @ ROOF
SCALE: 3/8"=1'-0"
HEEL HEIGHT BETWEEN 1 1/2' - 16'
BLOCKING REQ'D

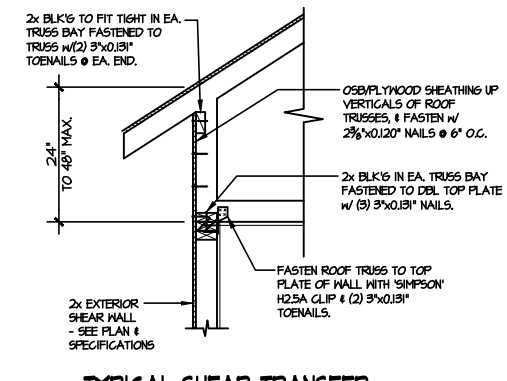

(A3) TYPICAL SHEAR TRANSFER DETAIL @ RAISED HEEL TRUSS
SCALE: 3/8"=1'-0"
HEEL HEIGHT UP TO 48" MAX

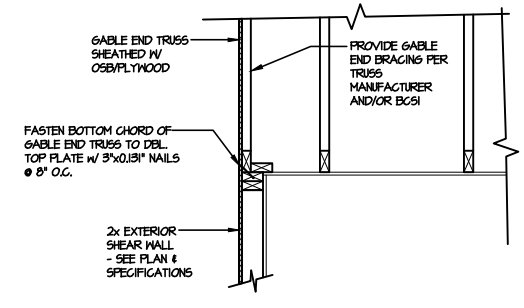

(B) TYPICAL GABLE END DETAIL
SCALE: 3/8"=1'-0"

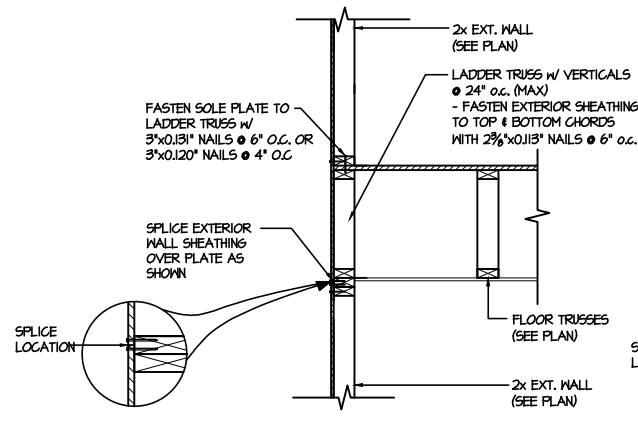

(C1) TYPICAL SHEAR TRANSFER DETAIL BETWEEN FLOORS @ EXTERIOR WALL
SCALE: 3/8"=1'-0"
PARALLEL FRAMING

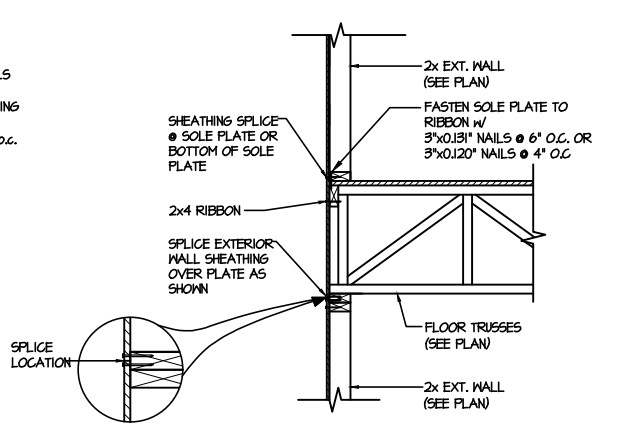

(C2) TYPICAL SHEAR TRANSFER DETAIL BETWEEN FLOORS @ EXTERIOR WALL
SCALE: 3/8"=1'-0"
PERPENDICULAR FRAMING

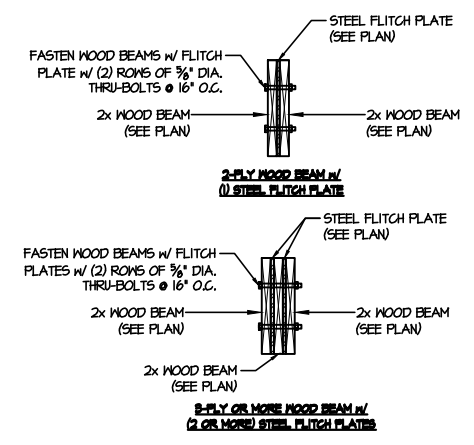

(D) TYPICAL FLITCH BEAM CONNECTION DETAIL
SCALE: 3/4"=1'-0"

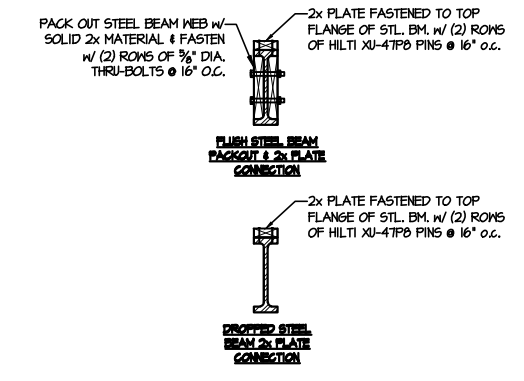

(E) TYPICAL STEEL BEAM CONNECTION DETAIL
SCALE: 3/4"=1'-0"

LETTERED DETAILS ARE TYPICAL FOR THIS HOME & SHALL BE IMPLEMENTED IN ALL APPLICABLE AREAS. THESE DETAILS ARE NOT "CUT" ON THE PLANS.

NUMBERED DETAILS ARE PLAN SPECIFIC AND ARE ONLY REQUIRED WHERE SPECIFICALLY INDICATED ("CUT") ON THE PLANS.

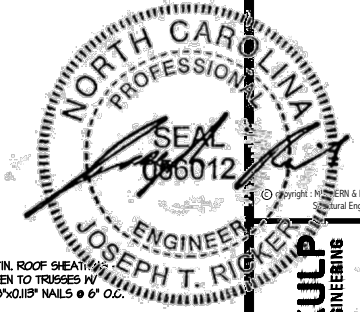

MULHERN+KULP
RESIDENTIAL STRUCTURAL ENGINEERING
300 Duneside Ave., Building 4 - Aurbur, PA 15282
P: 724-698-0001 • mulhern+kulp.com
NC LICENSE #C-3825

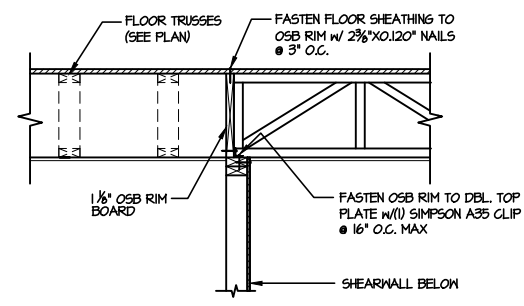

1 SHEAR TRANSFER DETAIL @ INTERIOR SHEARWALL BELOW
SCALE: 3/4"=1'-0" PARALLEL FRAMING

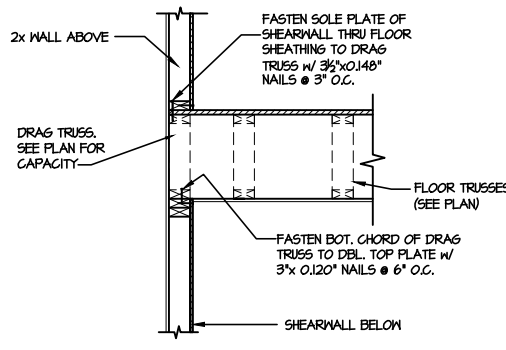

2 SHEAR TRANSFER DETAIL @ INT. SHEARWALL ABOVE & BELOW
SCALE: 3/4"=1'-0" EDGE OF FRAMING

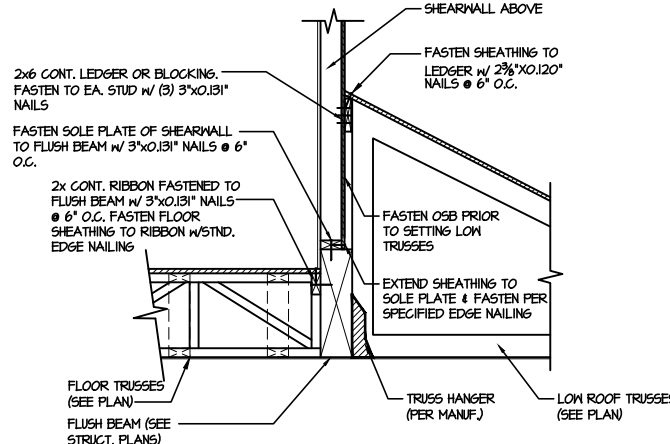

3 SHEAR TRANSFER DETAIL @ EXTERIOR SHEARWALL ABOVE
SCALE: 3/4"=1'-0"

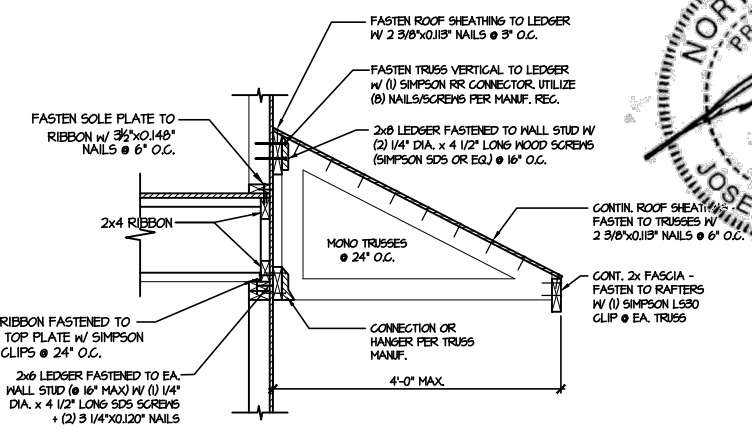

4 DETAIL @ SHED ROOF
SCALE: 3/8"=1'-0"

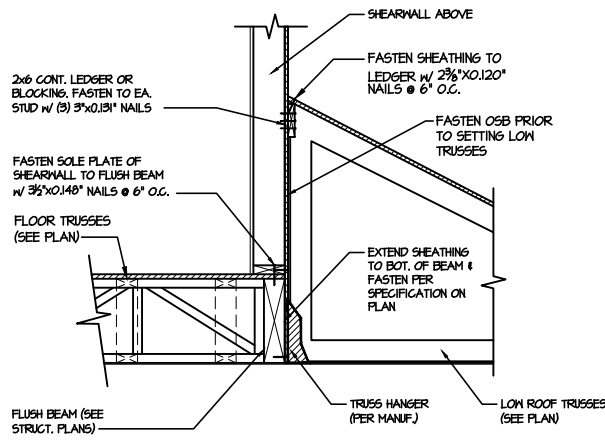

5 SHEAR TRANSFER DETAIL @ EXTERIOR SHEARWALL ABOVE
SCALE: 3/4"=1'-0"

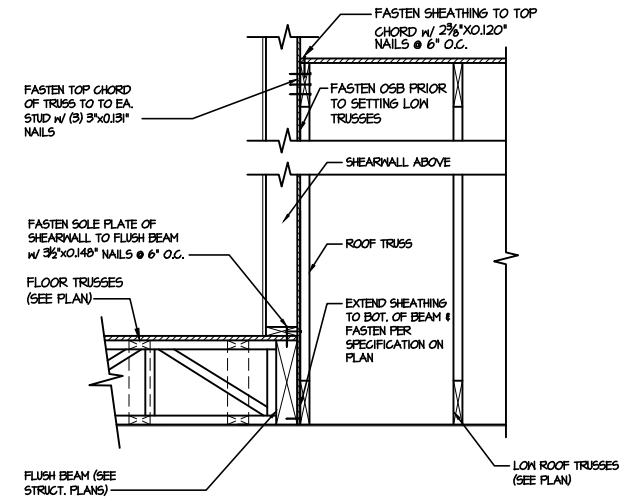

6 SHEAR TRANSFER DETAIL @ EXTERIOR SHEARWALL ABOVE
SCALE: 3/4"=1'-0"

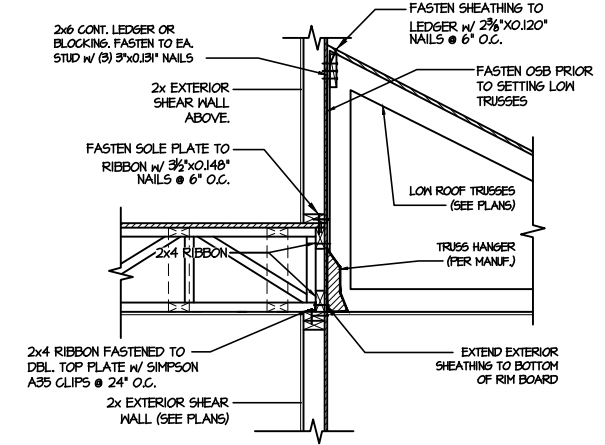

7 TYPICAL SHEAR TRANSFER DETAIL BETWEEN FLOORS @ INTERIOR WALL
SCALE: 3/4"=1'-0"

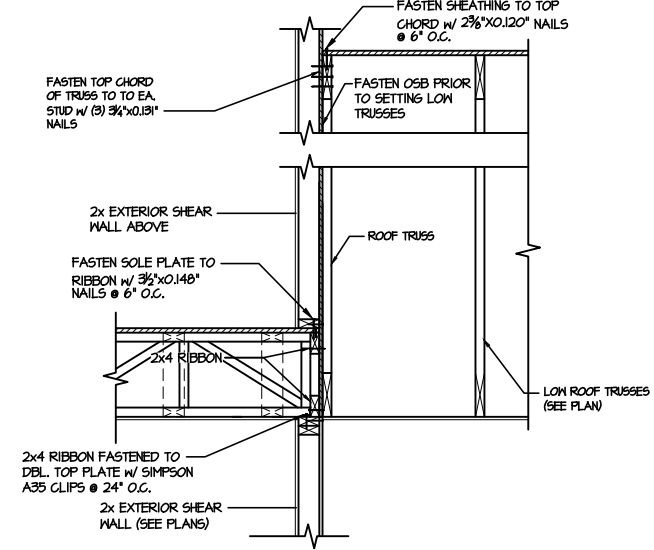

8 TYPICAL SHEAR TRANSFER DETAIL BETWEEN FLOORS @ INTERIOR WALL
SCALE: 3/4"=1'-0"

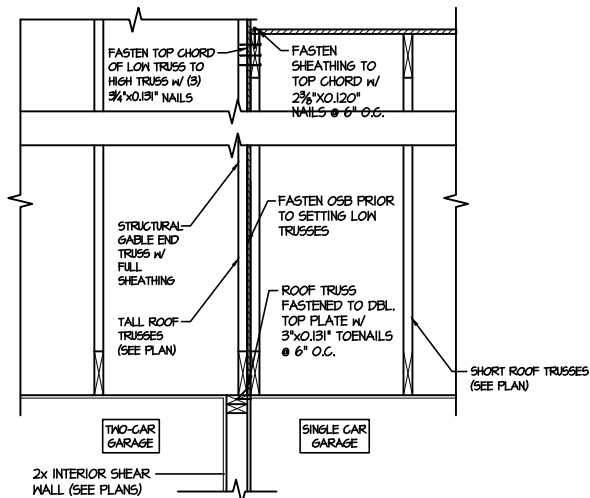

9 TYPICAL SHEAR TRANSFER DETAIL BETWEEN GARAGE BAYS
SCALE: 3/4"=1'-0"

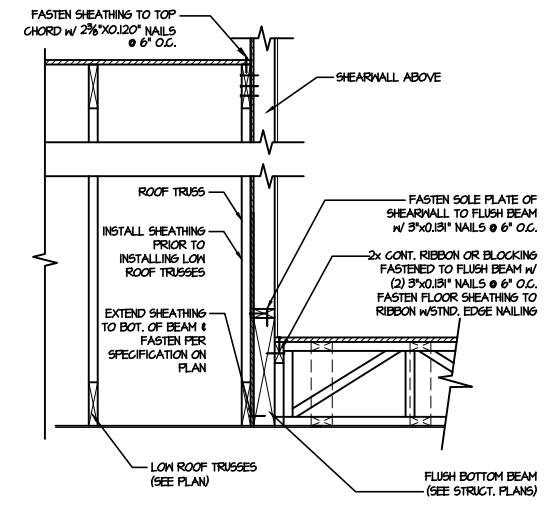

13 SHEAR TRANSFER DETAIL @ EXTERIOR SHEARWALL ABOVE
SCALE: 3/4"=1'-0"

M&K project number:
126-23047
project mgr: JTR
drawn by: JAD
issue date: 01-27-24

REVISIONS:
date: initial:

DRB HOMES

FRAMING DETAILS
HONEYCUTT HILLS
LOT 29 - DRAYTON 3
RALEIGH, NC

sheet:
SD2.1A

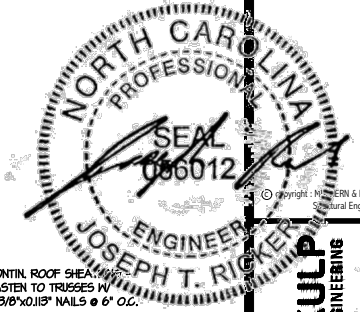

MULHERN+KULP
RESIDENTIAL STRUCTURAL ENGINEERING
300 Duneside Ave., Building 4 - Asheville, PA 15262
P: 715-698-0081 • mulhern+kulp.com
NC LICENSE #C-3825

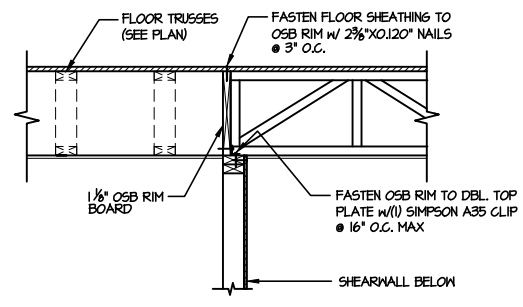

1 SHEAR TRANSFER DETAIL @ INTERIOR SHEARWALL BELOW
SCALE: 3/4"=1'-0" PARALLEL FRAMING

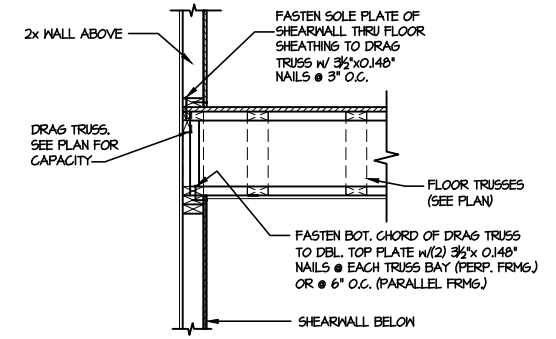

2 SHEAR TRANSFER DETAIL @ INT. SHEARWALL ABOVE & BELOW
SCALE: 3/4"=1'-0" EDGE OF FRAMING

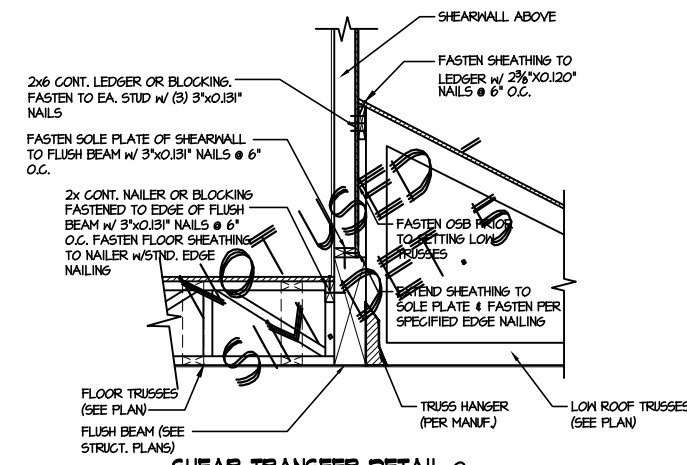

3 SHEAR TRANSFER DETAIL @ EXTERIOR SHEARWALL ABOVE
SCALE: 3/4"=1'-0"

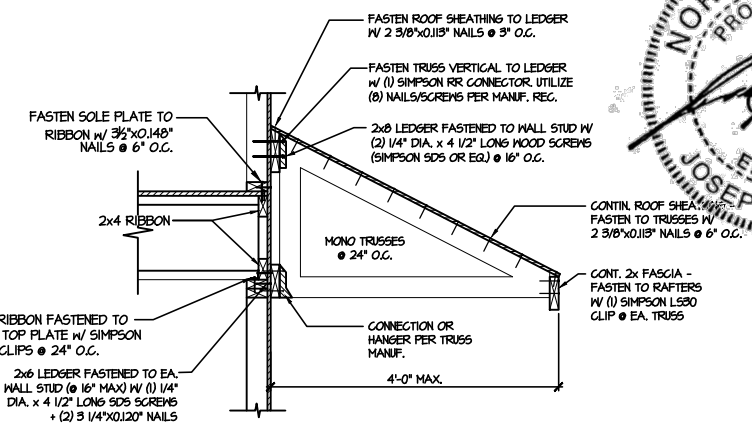

4 DETAIL @ SHED ROOF
SCALE: 3/8"=1'-0"

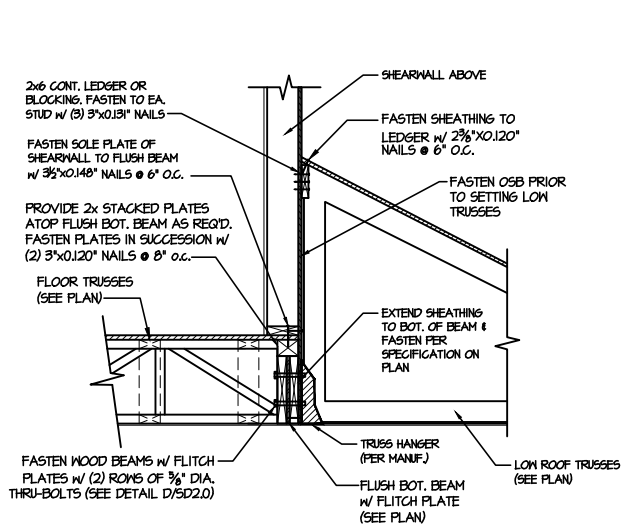

5 SHEAR TRANSFER DETAIL @ EXTERIOR SHEARWALL ABOVE
SCALE: 3/4"=1'-0"

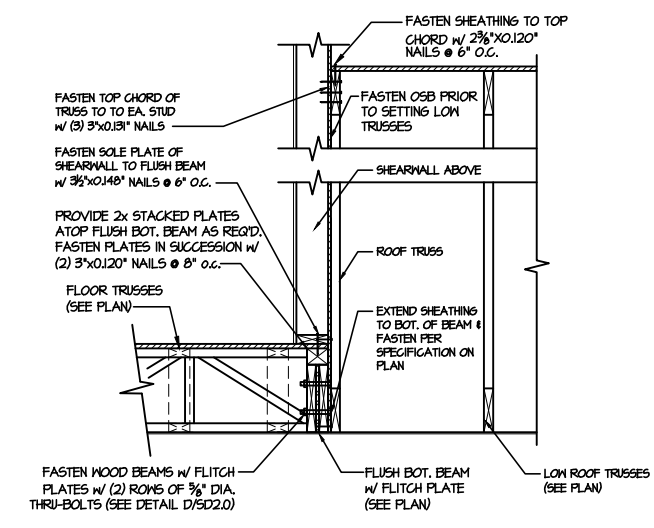

6 SHEAR TRANSFER DETAIL @ EXTERIOR SHEARWALL ABOVE
SCALE: 3/4"=1'-0"

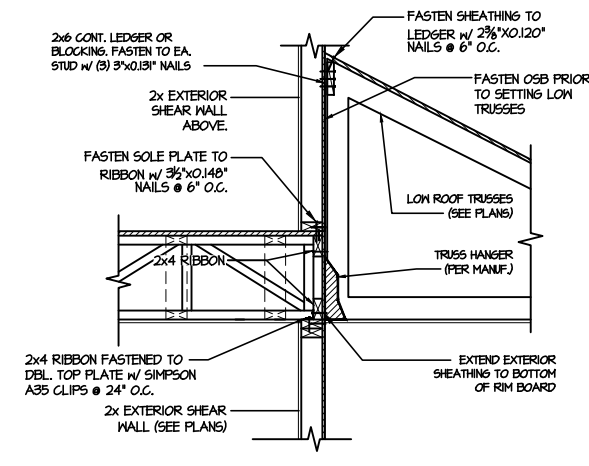

7 TYPICAL SHEAR TRANSFER DETAIL BETWEEN FLOORS @ INTERIOR WALL
SCALE: 3/4"=1'-0"

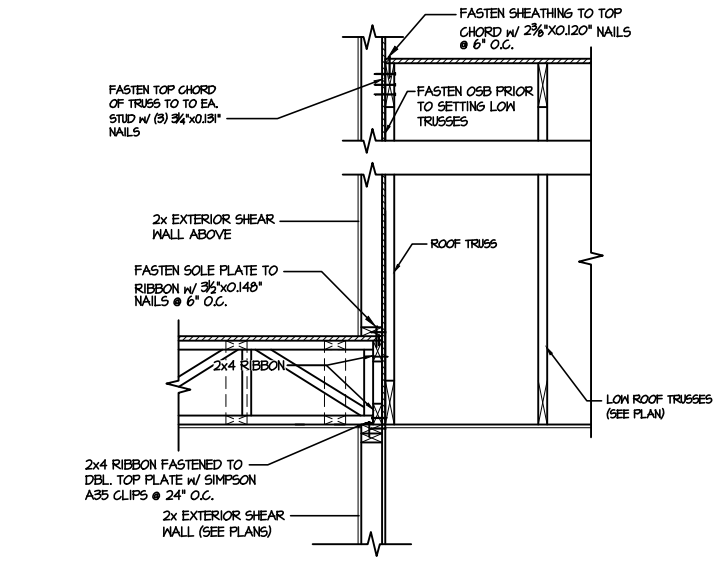

8 TYPICAL SHEAR TRANSFER DETAIL BETWEEN FLOORS @ INTERIOR WALL
SCALE: 3/4"=1'-0"

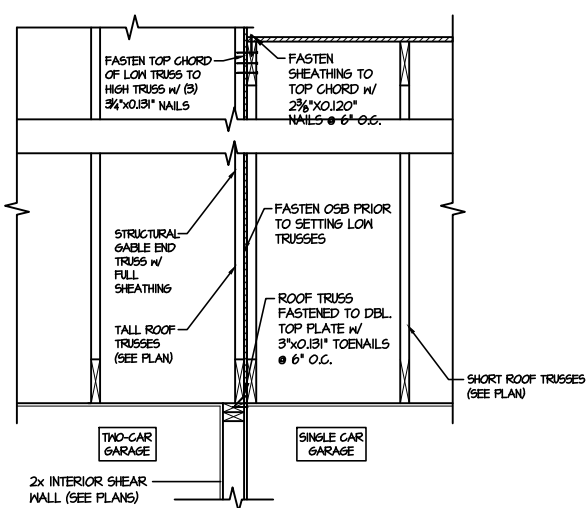

9 TYPICAL SHEAR TRANSFER DETAIL BETWEEN GARAGE BAYS
SCALE: 3/4"=1'-0"

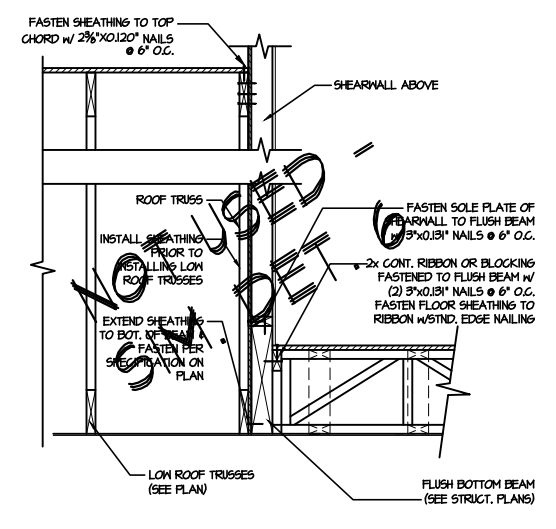

13 SHEAR TRANSFER DETAIL @ EXTERIOR SHEARWALL ABOVE
SCALE: 3/4"=1'-0"

M&K project number: 126-23047
project mgr: JTR
drawn by: JAD
issue date: 01-27-24

REVISIONS table with columns for date, initial, and description.

DRB HOMES

FRAMING DETAILS
HONEYCUTT HILLS
LOT 29 - DRAYTON 3
RALEIGH, NC

sheet: SD2.1B

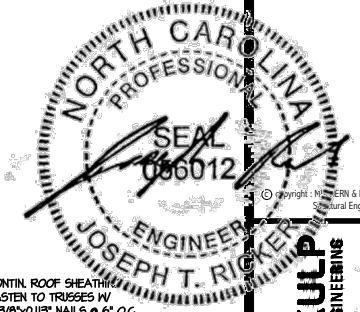

MULHERN+KULP
RESIDENTIAL STRUCTURAL ENGINEERING
300 Dunsmuir Ave., Building 4 - Asheville, NC 28801
P: 252-698-0888 • mulhern+kulp.com
NC LICENSE #C-3825

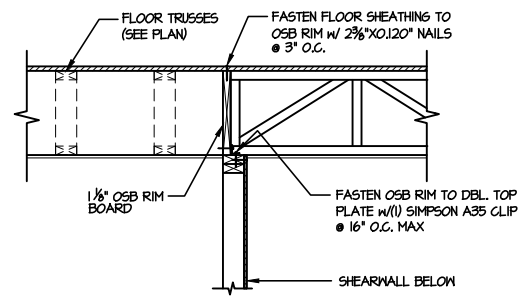

1 SHEAR TRANSFER DETAIL @ INTERIOR SHEARWALL BELOW
SCALE: 3/4"=1'-0" PARALLEL FRAMING

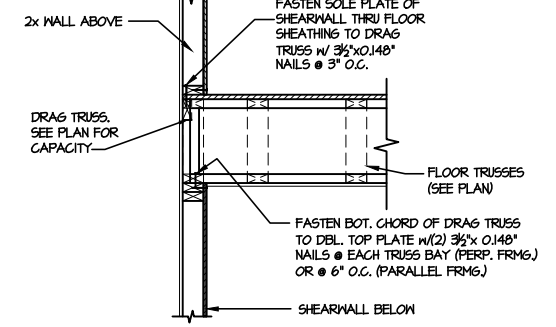

2 SHEAR TRANSFER DETAIL @ INT. SHEARWALL ABOVE & BELOW
SCALE: 3/4"=1'-0" EDGE OF FRAMING

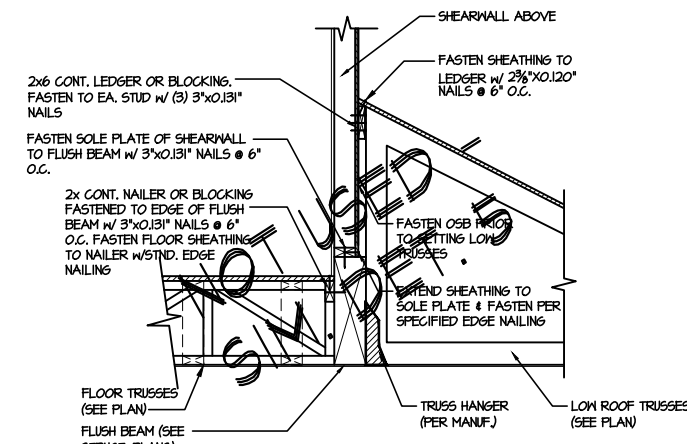

3 SHEAR TRANSFER DETAIL @ EXTERIOR SHEARWALL ABOVE
SCALE: 3/4"=1'-0"

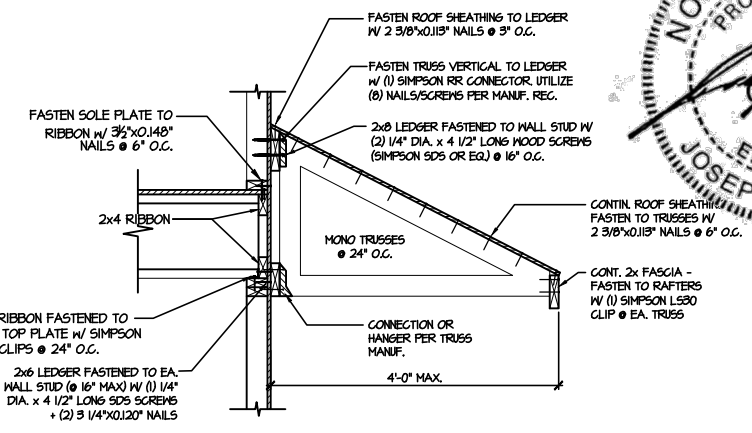

4 DETAIL @ SHED ROOF
SCALE: 3/8"=1'-0"

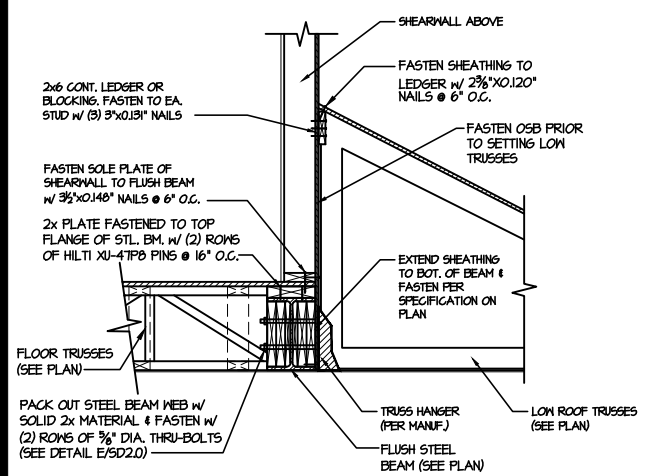

5 SHEAR TRANSFER DETAIL @ EXTERIOR SHEARWALL ABOVE
SCALE: 3/4"=1'-0"

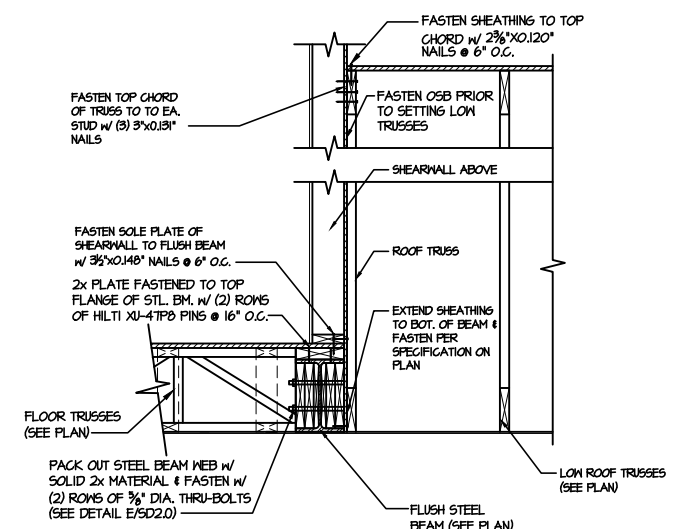

6 SHEAR TRANSFER DETAIL @ EXTERIOR SHEARWALL ABOVE
SCALE: 3/4"=1'-0"

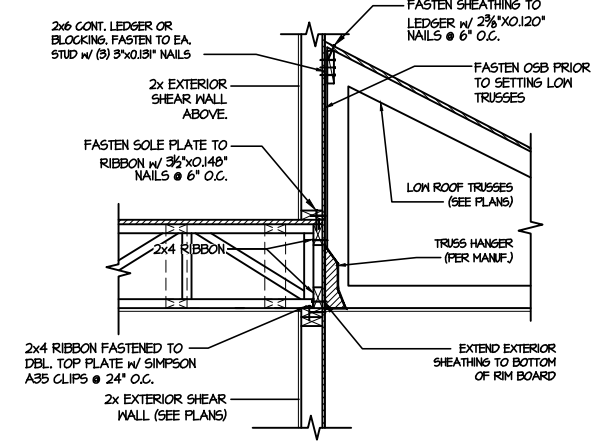

7 TYPICAL SHEAR TRANSFER DETAIL BETWEEN FLOORS @ INTERIOR WALL
SCALE: 3/4"=1'-0"

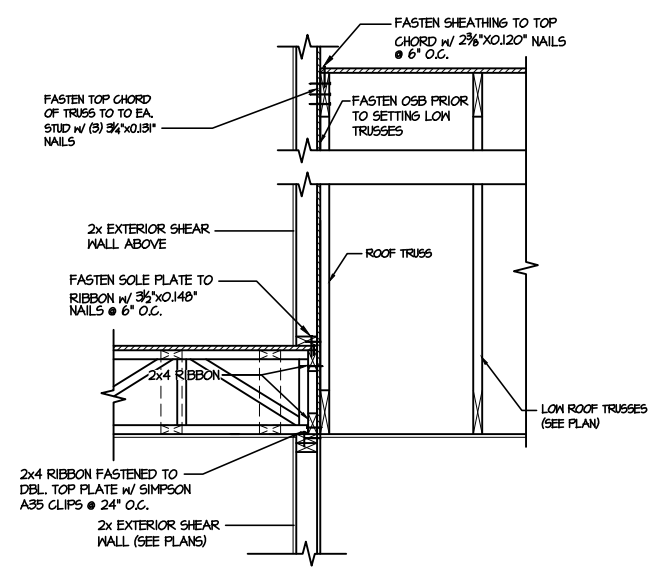

8 TYPICAL SHEAR TRANSFER DETAIL BETWEEN FLOORS @ INTERIOR WALL
SCALE: 3/4"=1'-0"

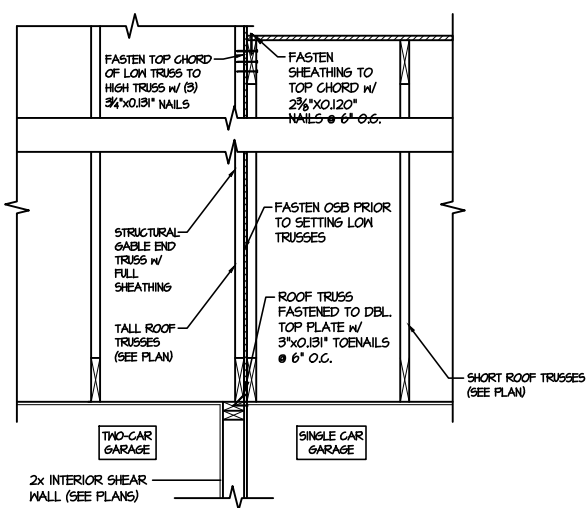

9 TYPICAL SHEAR TRANSFER DETAIL BETWEEN GARAGE BAYS
SCALE: 3/4"=1'-0"

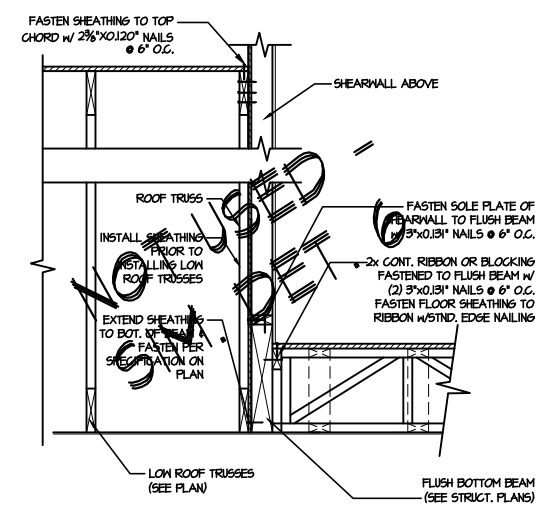

13 SHEAR TRANSFER DETAIL @ EXTERIOR SHEARWALL ABOVE
SCALE: 3/4"=1'-0"

M&K project number: 126-23047
project mgr: JTR
drawn by: JAD
issue date: 01-27-24

REVISIONS:
date: initial:



FRAMING DETAILS
HONEYCUTT HILLS
LOT 29 - DRAYTON 3
RALEIGH, NC

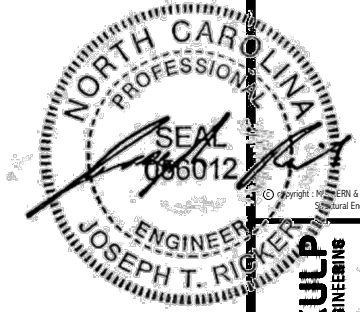

MULHERN+KULP
RESIDENTIAL STRUCTURAL ENGINEERING
300 Dunsmuir Ave., Building 4 - Asheville, NC 28802
P: 725.694.8881 - mulhern+kulp.com
NC LICENSE #C-3825



M&K project number:
126-23047
project mgr: JTR
drawn by: JAD
issue date: 01-27-24
REVISIONS:
date: initial:

DRB
HOMES

FRAMING DETAILS
HONEYCUTT HILLS
LOT 29 - DRAYTON 3
RALEIGH, NC

sheet:
SD2.2

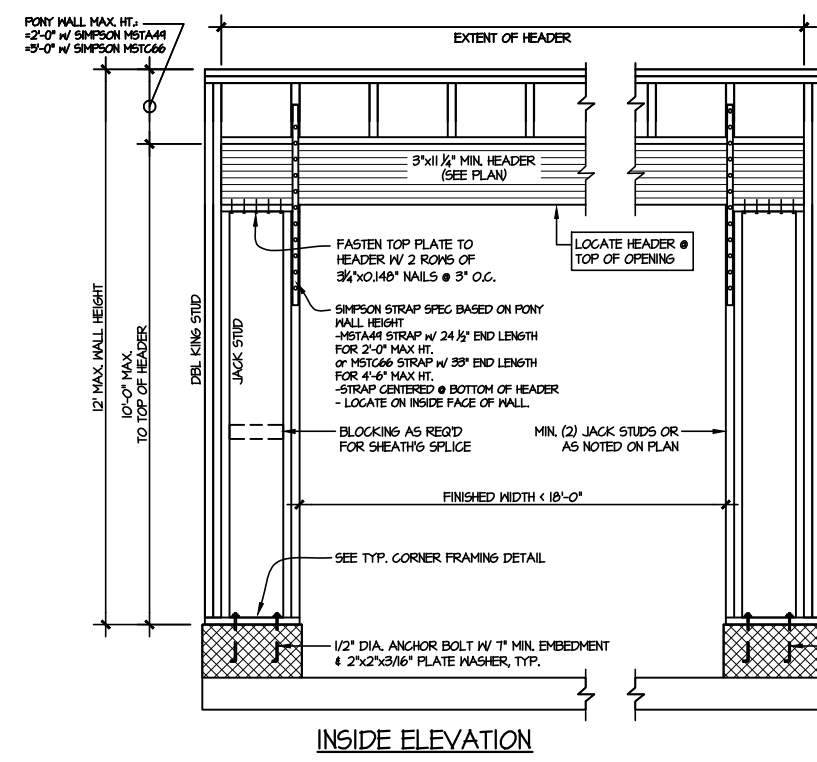
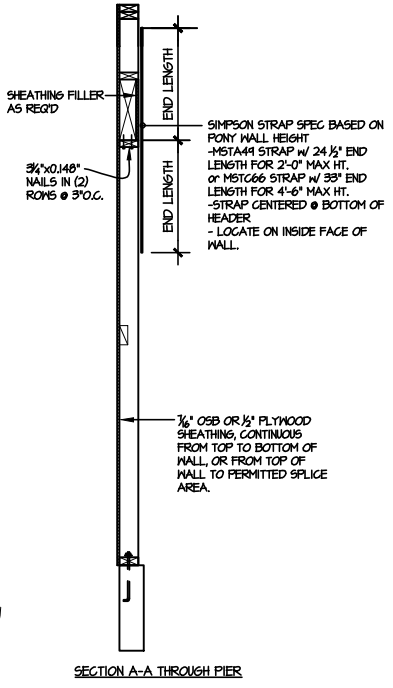
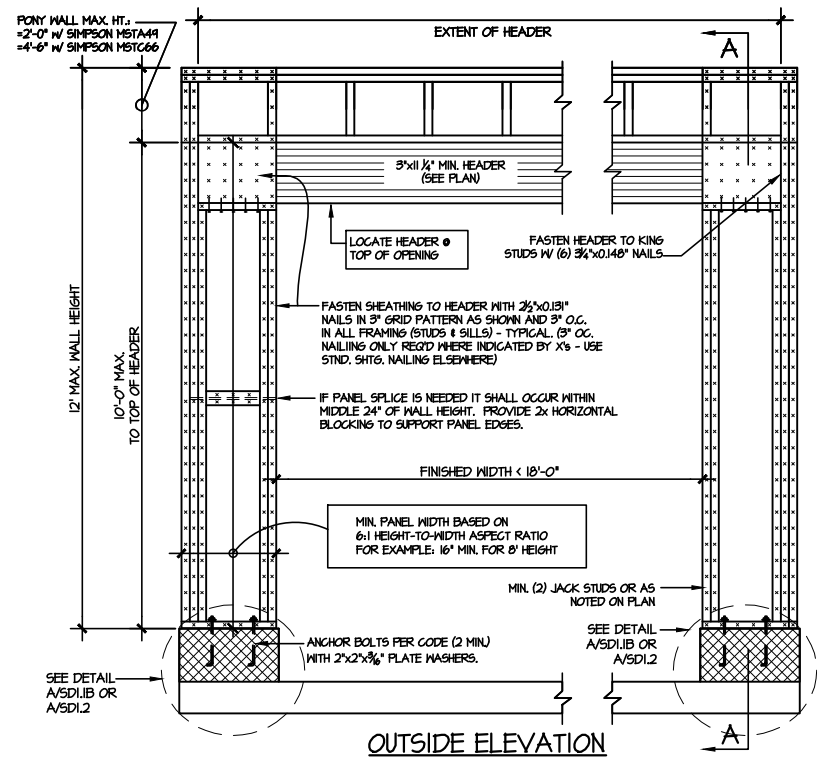

NOTE: ALL SHEATHABLE AREAS OF EXTERIOR WALL SHALL BE FULLY SHEATHED WITH 1/2" PLYWOOD OR 5/8" OSB

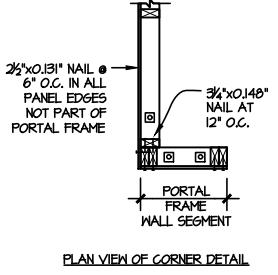

ALTERNATIVE TO 1/2" DIA. ANCHOR BOLT:
1) 1/2" DIA. THREADED ROD EPOXY SET
w/ 4 1/2" EMBED. (MIN) UTILIZING HILTI HY200
EPOXY ANCHORING SYSTEM (OR EQUAL)

② TWO SIDED GARAGE PORTAL FRAME BRACING
ELEVATION ON CMU STEM
SCALE: N.T.S.

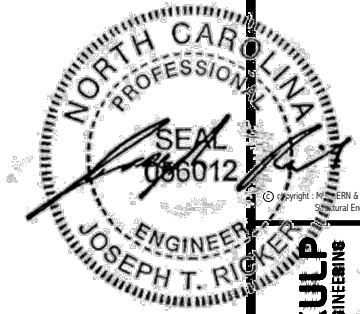

MULHERN+KULP
RESIDENTIAL STRUCTURAL ENGINEERING
300 Dismals Ave, Building 4 - Asheville, NC 28802
P: 252.698.8888 - mulhern+kulp.com
NC LICENSE #C-3825



M&K project number:
126-23047
project mgr: JTR
drawn by: JAD
issue date: 01-27-24

REVISIONS:
date: initial:



FRAMING DETAILS
HONEYCUTT HILLS
LOT 29 - DRAYTON 3
RALEIGH, NC

sheet:
SD3.0

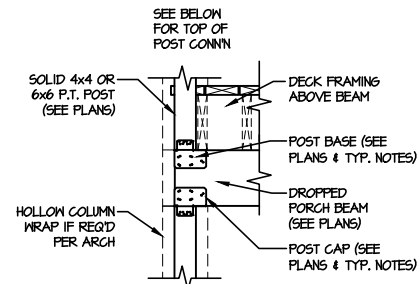

**TYPICAL CONNECTION
DETAIL @ 2nd FLOOR DECK**

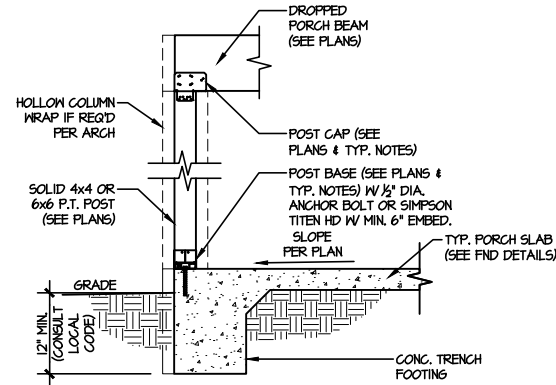

**TYPICAL PORCH
POST CONNECTION DETAIL**

3 SCALE: NONE SLAB ON GRADE SHOWN (RAISED SLAB SIM.)

EXTREME CARE MUST BE TAKEN
TO NOT SET ANY OF THESE
TRUSSES BACKWARDS

FLOOR DEPTH 14"

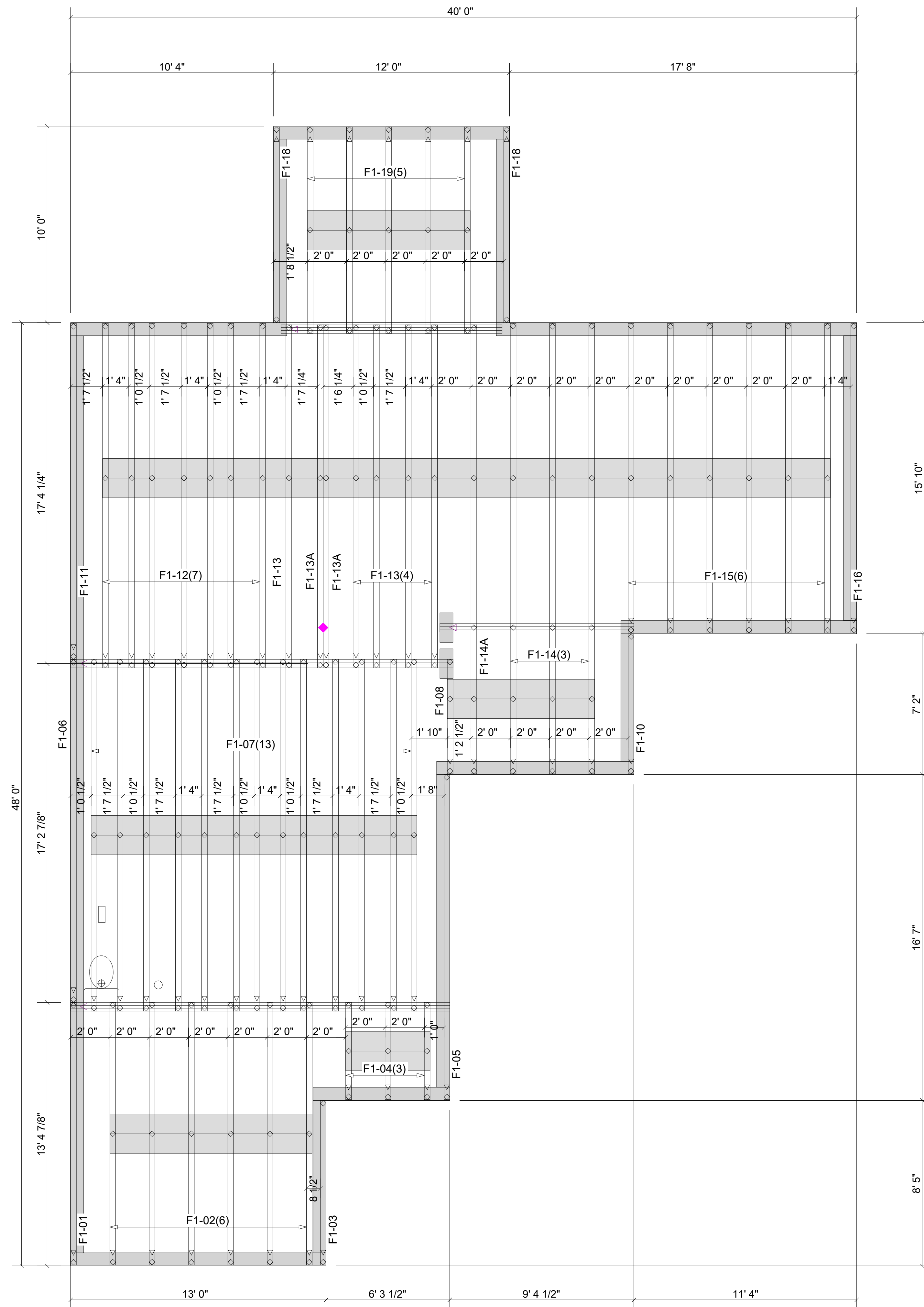

▲ = LEFT END OF TRUSS

FOR PERMIT

REVISIONS:



Moncks Corner/Easley, SC (800) 475-3999
Sparta, NC (336) 372-2226

Client: DRB GROUP-RALEIGH

Job: LOT 0.0029 HONEYCUTT HILL

Plan Information:

DRAYTON-3

NOT TO SCALE

Drawn By: CGT

Date: 01/15/25

Job #: 25-0669-F01

Sales Rep: KYLE GIBSON
Phone:

FLOOR

WARNING! Long span trusses, 60' or greater in length, require extreme care and experience for proper and safe handling and installation. For general handling and installation guidance, see the "Guide to Good Practice for Handling, Installing, Restraining & Bracing of Metal Plate Connected Wood Trusses ("BCSI"), JOINTLY PRODUCED BY SBCA and TPI. For project specific guidance, consult with a registered design professional. ATLANTIC assumes no responsibility for the handling, installation or bracing of trusses.

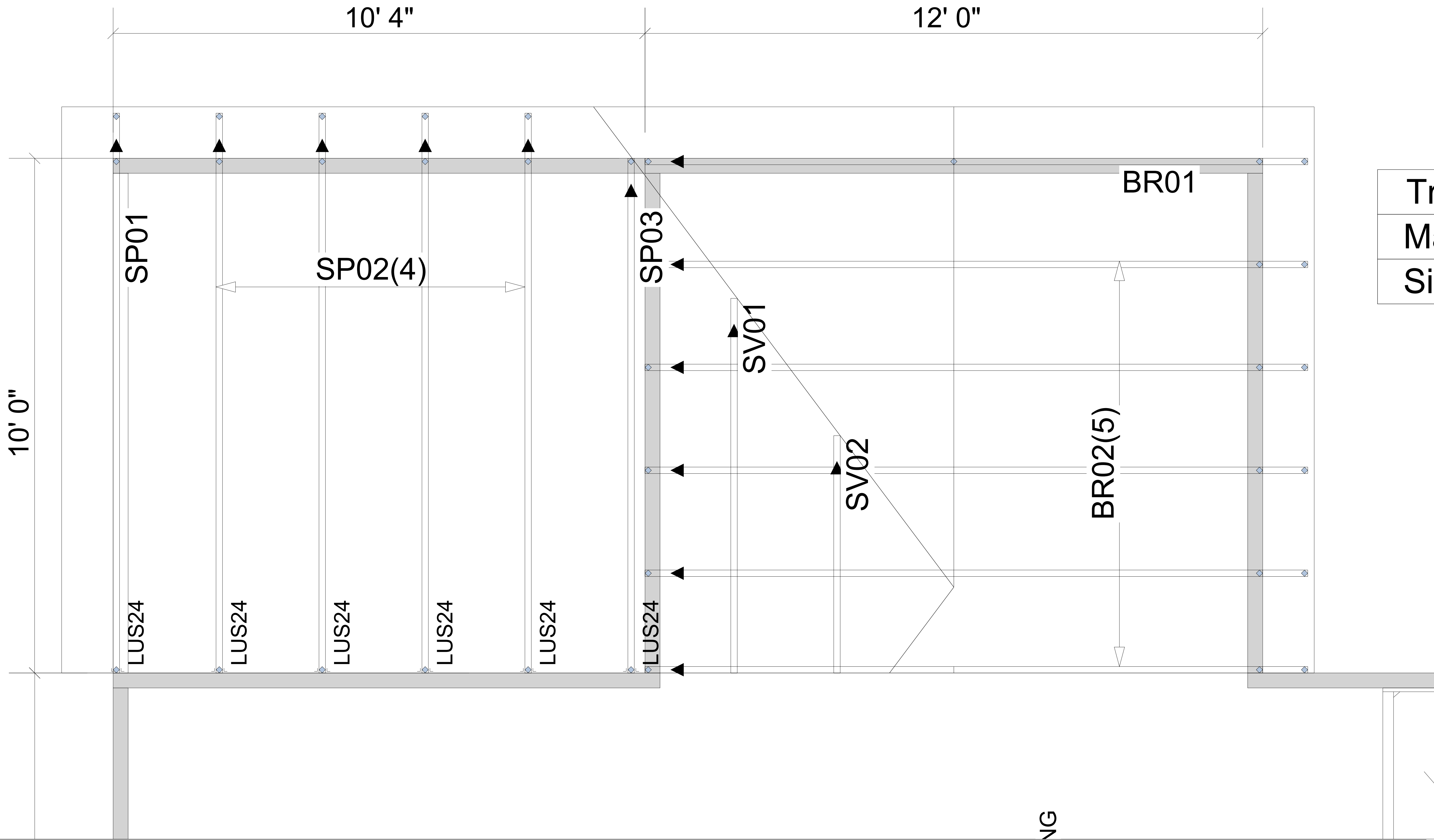

Tr
Ma
Si

▲ = LEFT END OF TRUSS

REVISIONS:



Moncks Corner/Easley, SC (800) 475-3999
Sparta, NC (336) 372-2226

FOR PERMIT

Client: DRB GROUP-RALEIGH	
Job: LOT 0.0029 HONEYCUTT HILL	
Plan Information: DRAYTON-3	
NOT TO SCALE	Date: 01/15/25
Drawn By: CGT	Sales Rep: KYLE GIBSON
	Phone: 25-0669-R01

ROOF

WARNING! Long span trusses, 60' or greater in length, require extreme care and experience for proper and safe handling and installation. For general handling and installation guidance, see the "Guide to Good Practice for Handling, Installing, Restraining & Bracing of Metal Plate Connected Wood Trusses ("BCSI"), JOINTLY PRODUCED BY SBCA and TPI. For project specific guidance, consult with a registered design professional. ATLANTIC assumes no responsibility for the handling, installation or bracing of trusses.

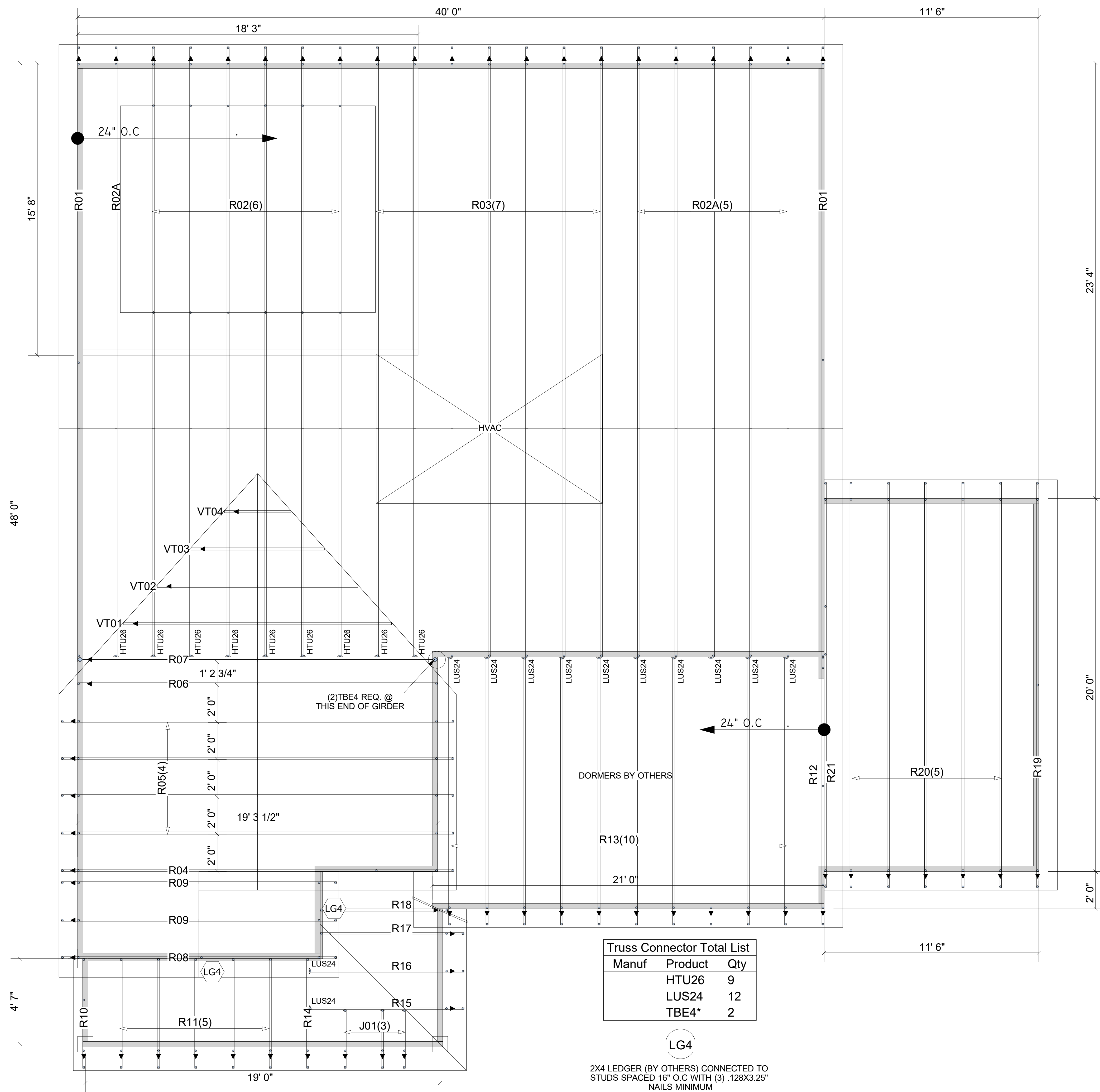

Truss Connector Total List		
Manuf	Product	Qty
	HTU26	9
	LUS24	12
	TBE4*	2

LG4

2X4 LEDGER (BY OTHERS) CONNECTED TO STUDS SPACED 16" O.C WITH (3) .128X3.25" NAILS MINIMUM

▲ = LEFT END OF TRUSS

FOR PERMIT

REVISIONS:



Moncks Corner/Easley, SC (800) 475-3999
Sparta, NC (336) 372-2226

Client: DRB GROUP-RALEIGH

Job: LOT 0.0029 HONEYCUTT HILL

Plan Information: DRAYTON-3

NOT TO SCALE

Drawn By: CGT

Date: 01/15/25

Job #: 25-0669-R01

Sales Rep: KYLE GIBSON
Phone:

ROOF

WARNING! Long span trusses, 60' or greater in length, require extreme care and experience for proper and safe handling and installation. For general handling and installation guidance, see the "Guide to Good Practice for Handling, Installing, Restraining & Bracing of Metal Plate Connected Wood Trusses ("BCSI"), JOINTLY PRODUCED BY SBCA and TPI. For project specific guidance, consult with a registered design professional. ATLANTIC assumes no responsibility for the handling, installation or bracing of trusses.

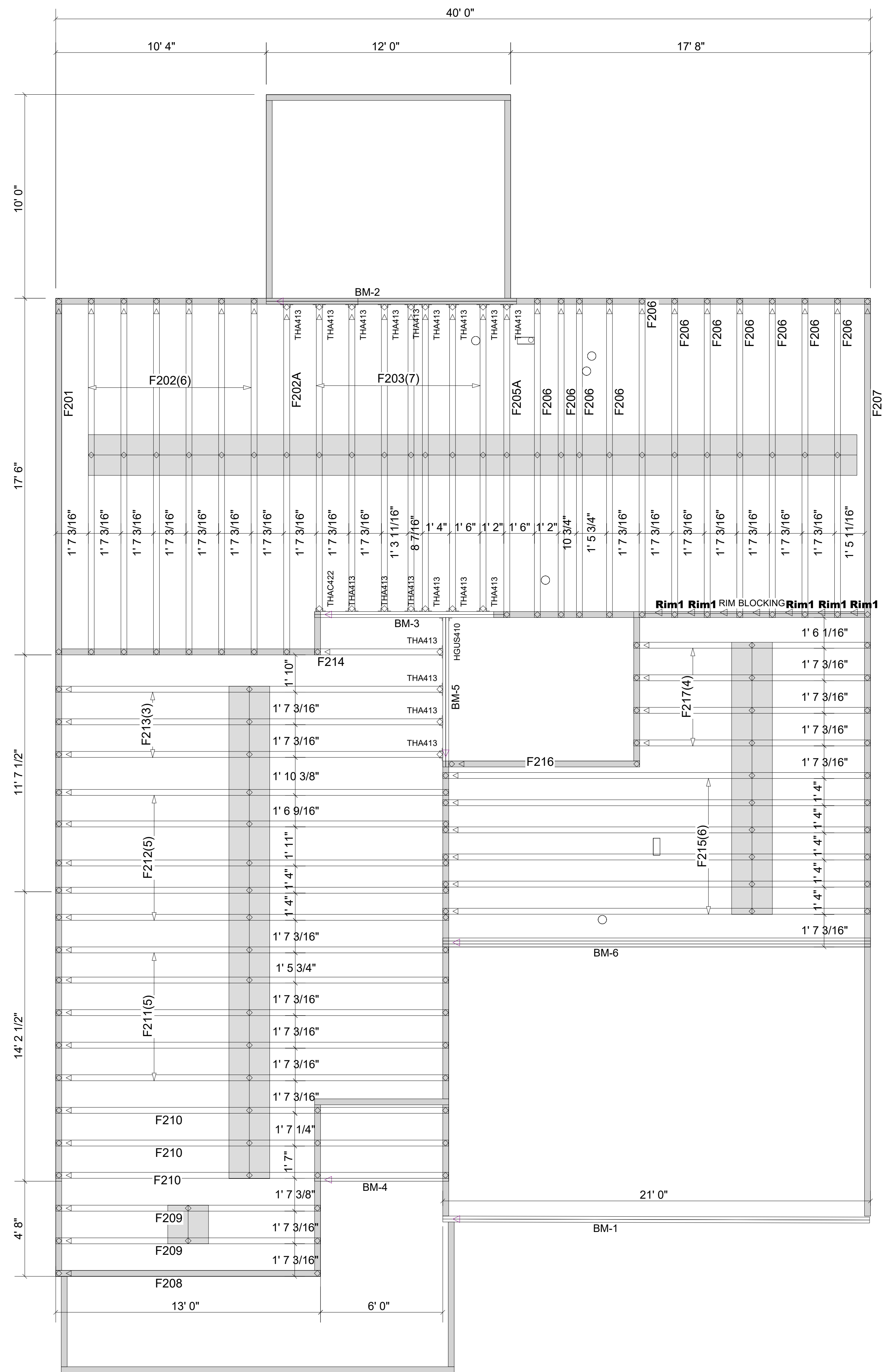

Products				
PlotID	Length	Product	Plies	Net Qty
BM-1	22' 0"	1-3/4" x 11-7/8" VERSA-LAM® 2.0 3100 SP	2	2
BM-2	14' 0"	1-3/4" x 14" VERSA-LAM® 2.0 3100 SP	2	2
BM-3	10' 0"	1-3/4" x 14" VERSA-LAM® 2.0 3100 SP	2	2
BM-4	8' 0"	1-3/4" x 14" VERSA-LAM® 2.0 3100 SP	1	1
BM-5	8' 0"	1-3/4" x 14" VERSA-LAM® 2.0 3100 SP	2	2
BM-6	22' 0"	1-3/4" x 18" VERSA-LAM® 2.0 3100 SP	3	3
Rim1	12' 0"	1-1/8" x 14" BC RIM BOARD OSB	1	1

Connector Summary			
Qty	Manuf	Product	Flange
1	Simpson	HGUS410	None

Truss Connector Total List		
Manuf	Product	Qty
Simpson	THA413	19
Simpson	THAC422	1

▲ = LEFT END OF TRUSS

REVISIONS:



Moncks Corner/Easley, SC (800) 475-3999
Sparta, NC (336) 372-2226

FOR PERMIT

Client: DRB GROUP-RALEIGH

Job: LOT 0.0029 HONEYCUTT HILL

Plan Information:

DRAYTON-3

NOT TO SCALE

Date: 01/15/25

Job #:

Sales Rep: KYLE GIBSON

Drawn By: CGT

Phone:

FLOOR

WARNING! Long span trusses, 60' or greater in length, require extreme care and experience for proper and safe handling and installation. For general handling and installation guidance, see the "Guide to Good Practice for Handling, Installing, Restraining & Bracing of Metal Plate Connected Wood Trusses ("BCSI"), JOINTLY PRODUCED BY SBCA and TPI. For project specific guidance, consult with a registered design professional. ATLANTIC assumes no responsibility for the handling, installation or bracing of trusses.