

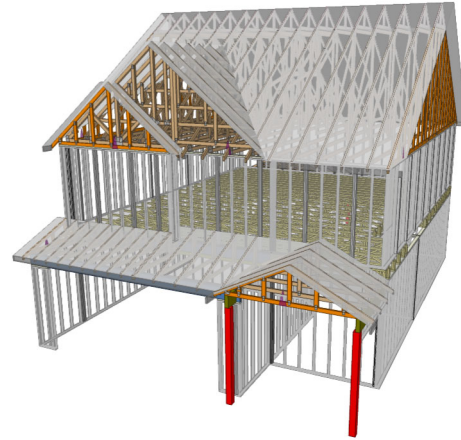

Carter Sanford Component Plant  
298 Harvey Faulk Rd  
Sanford, NC 27332

Phone #:919-775-1450



**Builder: Wellco Contractor**

**Model: 132 Hidden Lakes - Plan 10  
GLH**

**THE PLACEMENT PLAN NOTES:**

1. The Placement Plan is a diagram for truss installation. It is not an engineered drawing and has not been reviewed by an engineer. The Owner/Building Designer is responsible for obtaining an engineer's review if one is required by the local jurisdiction.
2. The responsibilities of the Owner, Contractor, Building Designer, Component Designer and Component Manufacturer shall be as set forth in ANSI/TPI 1. Capitalized terms shall be as defined in ANSI/TP 1 unless otherwise indicated.
3. Each Component is designed as an individual component utilizing information provided by others. The Owner/Building Designer is responsible for reviewing all Component Submittal Packages and individual Component Design Drawings for compliance with the Construction Documents and compatibility with the overall Building design.
4. Contractor will not proceed with component installation until the Owner/Building Designer has reviewed the Component Submittal Package. Questions on the suitability of any Component will be resolved by the Building Designer.
5. The Building Designer and Contractor are responsible for all temporary and permanent bracing.
6. The Placement Plan assumes the building is dimensionally correct, structurally sound, and in a suitable condition to support each Component during installation and thereafter, including but not limited to installation of all bearing points. Proper design and construction of all structural components, including foundations, headers, beams, walls and columns are the responsibility of the Owner, Building Designer and Contractor.
7. Do not cut, drill, or modify any Component without first consulting the Component Manufacturer or Building Designer. Damaged Components shall not be installed unless directed by the Building Designer or approved by the Component Manufacturer.
8. Components must be handled and installed following all applicable safety standards and best practices, including but not limited to BCSI, OSHA, TPI and local codes. Failure to properly handle, brace or otherwise install Component can result in serious injury or death.
9. All uplift connectors shown within these documents are recommendations only. Per ANSI/TPI 1, all uplift connectors are the responsibility of the building designer and or contractor.

**Approved By:** \_\_\_\_\_

**Date:** \_\_\_\_\_

\*\* FRAMER MUST REFER TO PLANS WHILE SETTING COMPONENTS. \*\* DAMAGED COMPONENTS SHOULD NOT BE INSTALLED UNLESS TOLD TO BY THE COMPONENT PLANT. \*\* ALL BEARING POINTS MUST BE INSTALLED PRIOR TO SETTING ANY COMPONENTS.

General Notes:

\*\* CUTTING OR DRILLING OF COMPONENTS SHOULD NOT BE DONE WITHOUT CONTRACTING COMPONENT SUPPLIER FIRST. CUSTOMER TAKES FULL RESPONSIBILITY FOR COMPONENTS IF CUT BEFORE AUTHORIZATION. \*\* ALL POINT LOADS FROM ABOVE MUST BE TRANSFERRED TO BEARING FROM UNDER SIDE OF SHEATHING.

TRIANGULAR SYMBOL NEAR END OF TRUSS INDICATES LEFT END OF TRUSS AS SHOWN ON INDIVIDUAL TRUSS DRAWINGS.

PLUMBING DROPS NOTED ARE IN THE APPROXIMATE LOCATIONS PER PLAN. BUILDER TO VERIFY LOCATIONS BEFORE SETTING TRUSSES.

REFER TO FINAL TRUSS ENGINEERING SHEETS FOR PLY TO PLY CONNECTIONS.

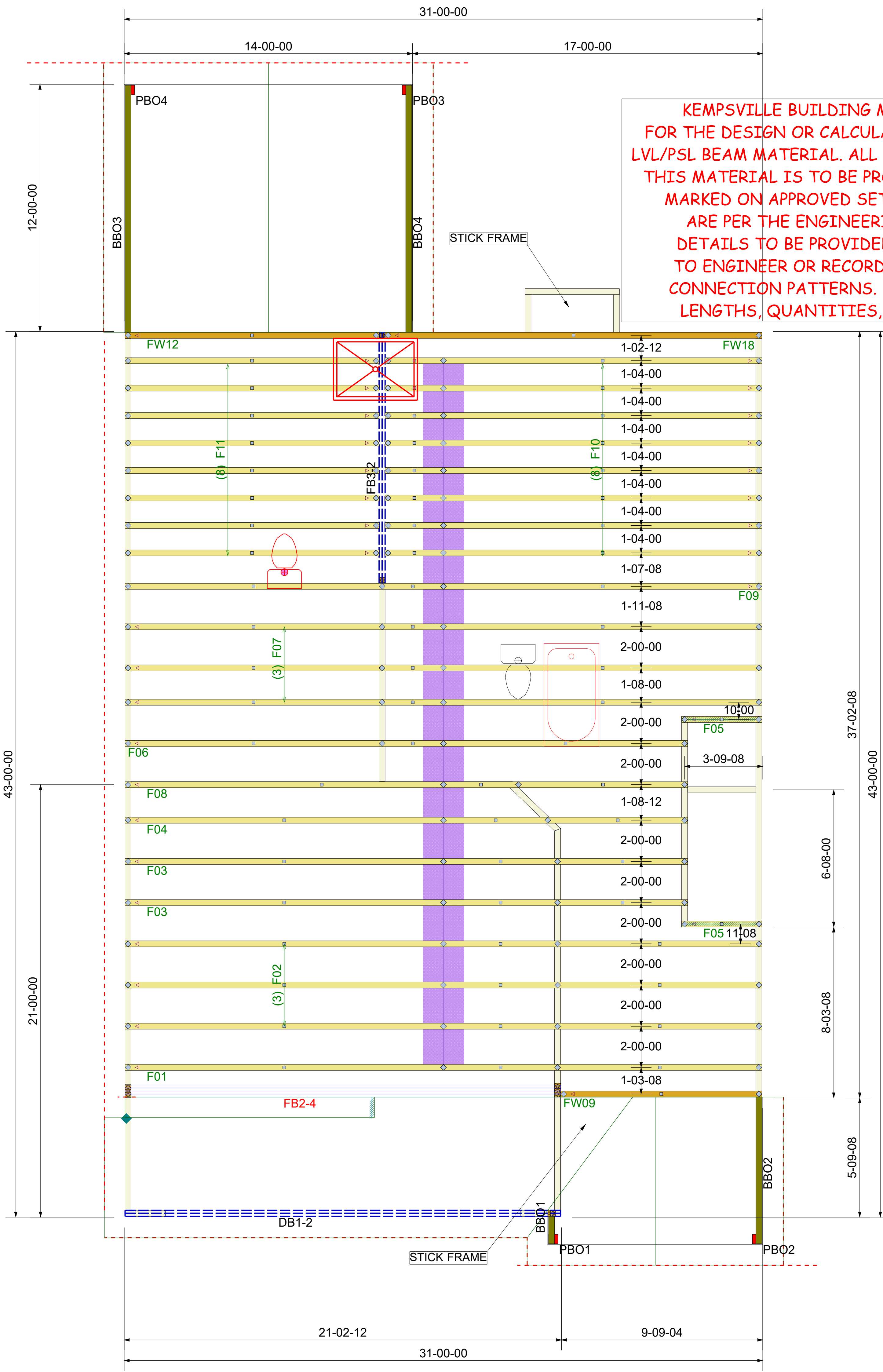

**KEMPSVILLE BUILDING MATERIALS IS NOT RESPONSIBLE FOR THE DESIGN OR CALCULATION OF ANY AND ALL I-JOIST AND LVL/PSL BEAM MATERIAL. ALL ENGINEERING AND INFORMATION FOR THIS MATERIAL IS TO BE PROVIDED BY THE ENGINEER OF RECORD MARKED ON APPROVED SET OF PLANS. ALL BEAM PLACEMENTS ARE PER THE ENGINEERING RECEIVED. ALL CONNECTION DETAILS TO BE PROVIDED BY ENGINEER OF RECORD. REFER TO ENGINEER OF RECORD FOR ALL MULTI-PLY LVL/ I-JOIST CONNECTION PATTERNS. BUILDER TO VERIFY ALL MATERIAL LENGTHS, QUANTITIES, AND SIZES PRIOR TO ORDERING.**

PlotID	Length	Product	Plies	Net Qty	Fab Type
FB3-2	14-00-00	2.0 RigidLam DF LVL 1-3/4 x 14	2	2	FF
DB1-2	22-00-00	2.1 RigidLam SP LVL 1-3/4 x 11-7/8	2	2	FF
FB2-4	22-00-00	2.1 RigidLam SP LVL 1-3/4 x 14	4	4	FF

Truss Connector Total List		
Manuf	Product	Qty
Simpson	One H2.5A	9

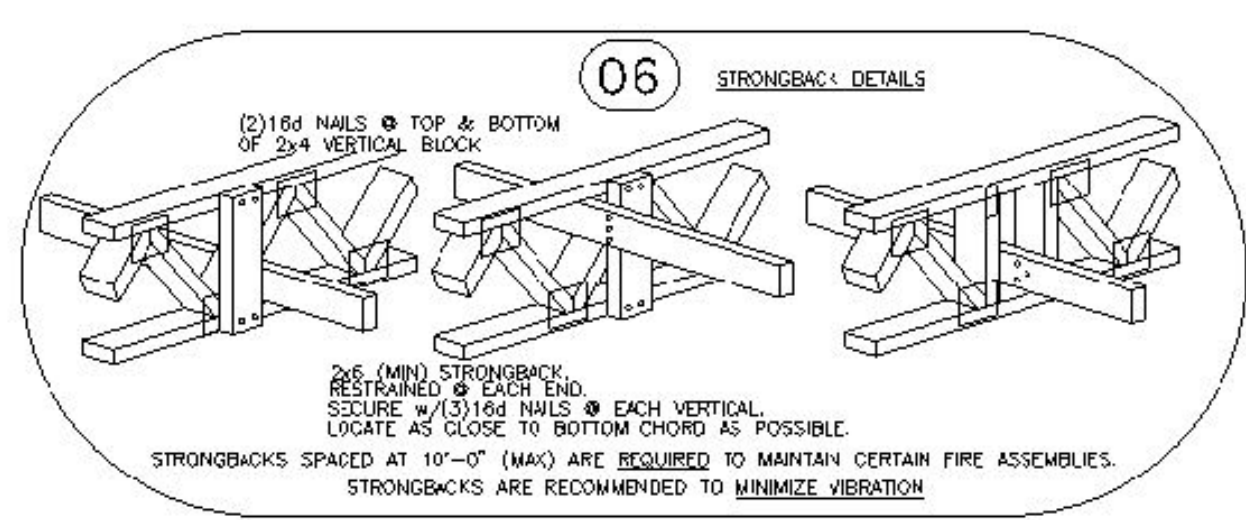
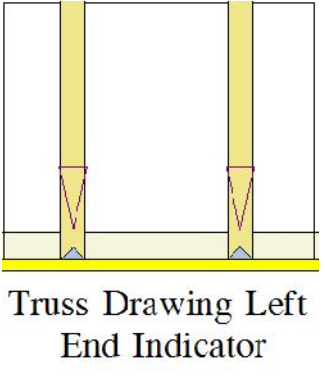

FB# - Flush Beam  
DB# - Dropped Beam  
BBO - Beam that is not supplied by the component plant

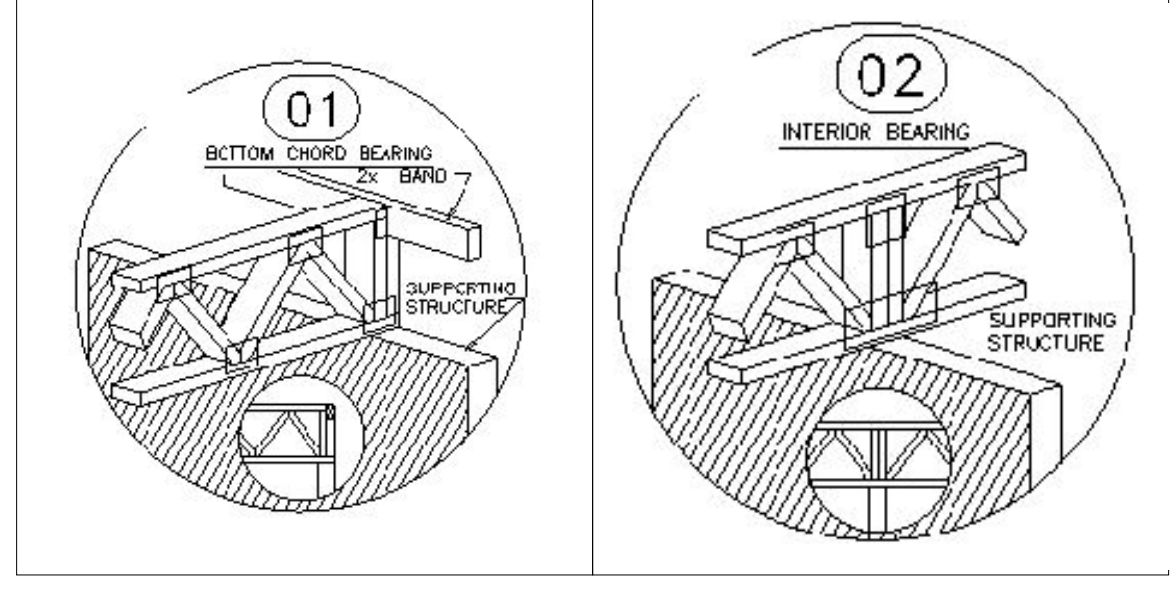

\*\* GIRDERS MUST BE FULLY CONNECTED TOGETHER PRIOR TO ADDING ANY LOADS. \*\* DIMENSIONS ARE READ AS: FOOT-INCH-SIXTEENTH. \*\* TRUSS TO TRUSS CONNECTIONS ARE TOE-NAILED, UNLESS NOTED OTHERWISE.

Scale: NTS  
Date: 1/12/2025  
Designer: Aaron Rogers  
Project Number: 25010024-A  
Sheet Number: 1/1

Wellco Contractor  
132 Hidden Lakes - 2nd Floor-Plan 10 GLH  
**FLOOR PLACEMENT PLAN**

**CARTER**  
Lumber

**THIS IS A TRUSS PLACEMENT DIAGRAM ONLY.** These trusses are designed as individual components to be incorporated into the building design at the specification of the building designer. See Individual design sheets for each truss design identified on the placement drawing. The building designer is responsible for temporary and permanent bracing of the roof and floor systems and for the overall structure. The design of the truss support structure including headers, beams, walls, and columns is the responsibility of the building designer. For general guidance regarding the bracing, consult "Bracing of Wood Truss" available from the Truss Plate Institute, 583 D'Onofrio Drive: Madison, WI 53179

Revisions
00/00/00 Name
00/00/00 Name
00/00/00 Name
00/00/00 Name
00/00/00 Name

**FB2-4 2.1E RigidLam LVL SP 1.750" X 14.000" 4-Ply - PASSED**

Level: Level

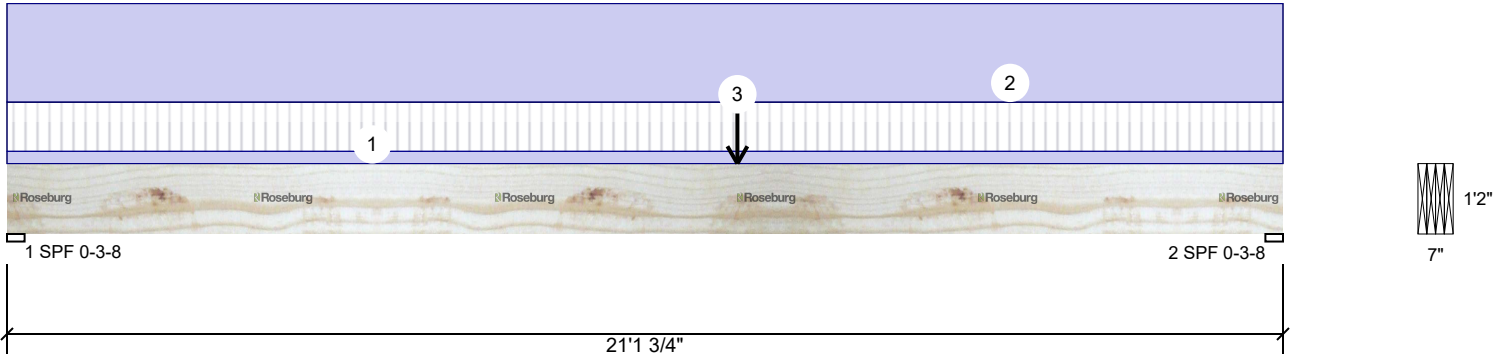

**Member Information**

Type:	Girder	Application:	Floor
Plies:	4	Design Method:	ASD
Moisture Condition:	Dry	Building Code:	IBC/IRC 2015
Deflection LL:	480	Load Sharing:	Yes
Deflection TL:	240	Deck:	Not Checked
Importance:	Normal - II		
Temperature:	Temp <= 100°F		

**Reactions UNPATTERNED lb (Uplift)**

Brg	Direction	Live	Dead	Snow	Wind	Const
1	Vertical	423	4236	0	0	0
2	Vertical	423	5272	0	0	0

**Bearings**

Bearing	Length	Dir.	Cap.	React D/L lb	Total	Ld. Case	Ld. Comb.
1 - SPF	3.500"	Vert	45%	4236 / 423	4659	L	D+L
2 - SPF	3.500"	Vert	55%	5272 / 423	5695	L	D+L

**Analysis Results**

Analysis	Actual	Location	Allowed	Capacity	Comb.	Case
Moment	41614 ft-lb	12' 1/4"	53613 ft-lb	78%	D	Uniform
Unbraced	43707 ft-lb	12' 1/4"	43947 ft-lb	99%	D+L	L
Shear	5111 lb	19' 8 1/4"	17052 lb	30%	D	Uniform
LL Defl inch	0.051 (L/4826)	10' 6 15/16"	0.517 (L/480)	10%	L	L
TL Defl inch	0.884 (L/281)	11' 1 1/8"	1.034 (L/240)	85%	D+L	L

**Design Notes**

- 1 Provide support to prevent lateral movement and rotation at the end bearings.
- 2 Girders are designed to be supported on the bottom edge only.
- 3 Multiple plies must be fastened together as per manufacturer's details.
- 4 Top loads must be supported equally by all plies.
- 5 Top must be laterally braced at a maximum of 4'3 7/8" o.c.
- 6 Bottom must be laterally braced at end bearings.
- 7 Lateral slenderness ratio based on single ply width.

ID	Load Type	Location	Trib Width	Side	Dead 0.9	Live 1	Snow 1.15	Wind 1.6	Const. 1.25	Comments
1	Uniform		1-0-0	Near Face	10 PSF	40 PSF	0 PSF	0 PSF	0 PSF	standard
2	Uniform			Top	80 PLF	0 PLF	0 PLF	0 PLF	0 PLF	wall
3	Point	12-1-4		Top	7000 lb	0 lb	0 lb	0 lb	0 lb	girder above
	Bearing Length	0-3-8								
	Self Weight				29 PLF					

<p><b>Notes</b></p> <p>Calculated Structured Designs is responsible only of the structural adequacy of this component based on the design criteria and loadings shown. It is the responsibility of the customer and/or the contractor to ensure the component suitability of the intended application, and to verify the dimensions and loads.</p> <p><b>Lumber</b></p> <ol style="list-style-type: none"> <li>1. Dry service conditions, unless noted otherwise</li> <li>2. LVL not to be treated with fire retardant or corrosive chemicals</li> </ol>	<p><b>Handling &amp; Installation</b></p> <ol style="list-style-type: none"> <li>1. LVL beams must not be cut or drilled</li> <li>2. Refer to manufacturer's product information regarding installation requirements, multi-ply fastening details, beam strength values, and code approvals</li> <li>3. Damaged Beams must not be used</li> <li>4. Design assumes top edge is laterally restrained</li> <li>5. Provide lateral support at bearing points to avoid lateral displacement and rotation</li> </ol>	<p>6. For flat roofs provide proper drainage to prevent ponding</p>	<p><b>Manufacturer Info</b></p> <p>Roseburg Forest Products 3661 Gateway Street Springfield, OR 97477 (541) 679-3311 www.roseburg.com APA: PR-L289, ICC-ES: ESR-1210</p>
			<p>This design is valid until 2/14/2027</p>

**FB3-2 2.1E RigidLam LVL SP 1.750" X 14.000" 2-Ply - PASSED**

Level: Level

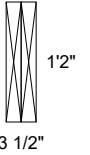
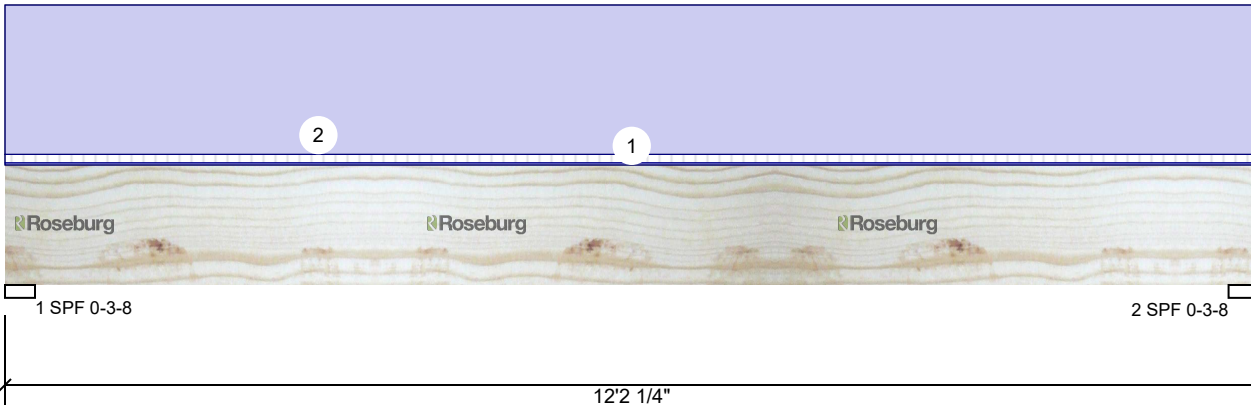

**Member Information**

Type:	Girder	Application:	Floor
Plies:	2	Design Method:	ASD
Moisture Condition:	Dry	Building Code:	IBC/IRC 2015
Deflection LL:	480	Load Sharing:	No
Deflection TL:	240	Deck:	Not Checked
Importance:	Normal - II		
Temperature:	Temp <= 100°F		

**Reactions UNPATTERNED Ib (Uplift)**

Brg	Direction	Live	Dead	Snow	Wind	Const
1	Vertical	244	4414	0	0	0
2	Vertical	244	4414	0	0	0

**Bearings**

Bearing	Length	Dir.	Cap.	React D/L lb	Total	Ld. Case	Ld. Comb.
1 - SPF	3.500"	Vert	89%	4414 / 244	4657	L	D+L
2 - SPF	3.500"	Vert	89%	4414 / 244	4657	L	D+L

**Analysis Results**

Analysis	Actual	Location	Allowed	Capacity	Comb.	Case
Moment	12455 ft-lb	6'1 1/8"	25775 ft-lb	48%	D	Uniform
Unbraced	13143 ft-lb	6'1 1/8"	13160 ft-lb	100%	D+L	L
Shear	3357 lb	10'8 3/4"	8526 lb	39%	D	Uniform
LL Defl inch (L/12056)	0.012	6'1 1/8"	0.293 (L/480)	4%	L	L
TL Defl inch (L/631)	0.223	6'1 1/8"	0.586 (L/240)	38%	D+L	L

**Design Notes**

- 1 Provide support to prevent lateral movement and rotation at the end bearings.
- 2 Girders are designed to be supported on the bottom edge only.
- 3 Multiple plies must be fastened together as per manufacturer's details.
- 4 Top loads must be supported equally by all plies.
- 5 Top must be laterally braced at a maximum of 7'9 3/4" o.c.
- 6 Bottom must be laterally braced at end bearings.
- 7 Lateral slenderness ratio based on single ply width.

ID	Load Type	Location	Trib Width	Side	Dead 0.9	Live 1	Snow 1.15	Wind 1.6	Const. 1.25	Comments
1	Uniform		1-0-0	Top	10 PSF	40 PSF	0 PSF	0 PSF	0 PSF	
2	Uniform			Top	700 PLF	0 PLF	0 PLF	0 PLF	0 PLF	
	Self Weight				14 PLF					

**Notes**

Calculated Structured Designs is responsible only of the structural adequacy of this component based on the design criteria and loadings shown. It is the responsibility of the customer and/or the contractor to ensure the component suitability of the intended application, and to verify the dimensions and loads.

**Lumber**

1. Dry service conditions, unless noted otherwise
2. LVL not to be treated with fire retardant or corrosive

**Handling & Installation**

1. LVL beams must not be cut or drilled
2. Refer to manufacturer's product information regarding installation requirements, multi-ply fastening details, beam strength values, and code approvals
3. Damaged Beams must not be used
4. Design assumes top edge is laterally restrained
5. Provide lateral support at bearing points to avoid lateral displacement and rotation

6. For flat roofs provide proper drainage to prevent ponding

This design is valid until 2/14/2027

**Manufacturer Info**

Roseburg Forest Products  
3661 Gateway Street  
Springfield, OR 97477  
(541) 679-3311  
www.roseburg.com  
APA: PR-L289, ICC-ES: ESR-1210

Trenco  
818 Soundside Rd  
Edenton, NC 27932

Re: 25010029-A  
132 Hidden Lakes North-2nd Floor-Plan 10 GRH

The truss drawing(s) referenced below have been prepared by Truss Engineering Co. under my direct supervision based on the parameters provided by Carter Components (Sanford, NC)).

Pages or sheets covered by this seal: I70703737 thru I70703750

My license renewal date for the state of North Carolina is December 31, 2025.

North Carolina COA: C-0844



January 13, 2025

Johnson, Andrew

**IMPORTANT NOTE:** The seal on these truss component designs is a certification that the engineer named is licensed in the jurisdiction(s) identified and that the designs comply with ANSI/TPI 1. These designs are based upon parameters shown (e.g., loads, supports, dimensions, shapes and design codes), which were given to MiTek or TRENCO. Any project specific information included is for MiTek's or TRENCO's customers file reference purpose only, and was not taken into account in the preparation of these designs. MiTek or TRENCO has not independently verified the applicability of the design parameters or the designs for any particular building. Before use, the building designer should verify applicability of design parameters and properly incorporate these designs into the overall building design per ANSI/TPI 1, Chapter 2.

Job 25010029-A	Truss FW18	Truss Type Floor Supported Gable	Qty 1	Ply 1	132 Hidden Lakes North-2nd Floor-Plan 10 GRH I70703737 Job Reference (optional)
-------------------	---------------	-------------------------------------	----------	----------	---

Carter Components (Sanford, NC), Sanford, NC - 27332,

Run: 8.73 S Dec 5 2024 Print: 8.730 S Dec 5 2024 MiTek Industries, Inc. Sun Jan 12 16:05:45  
ID:CWoH92gzU9aM?IXbRwCL7azwhrK-RfC?PsB70Hq3NSgPqnL8w3uITXbGKWrCdoi7J4zJC?f

Page: 1

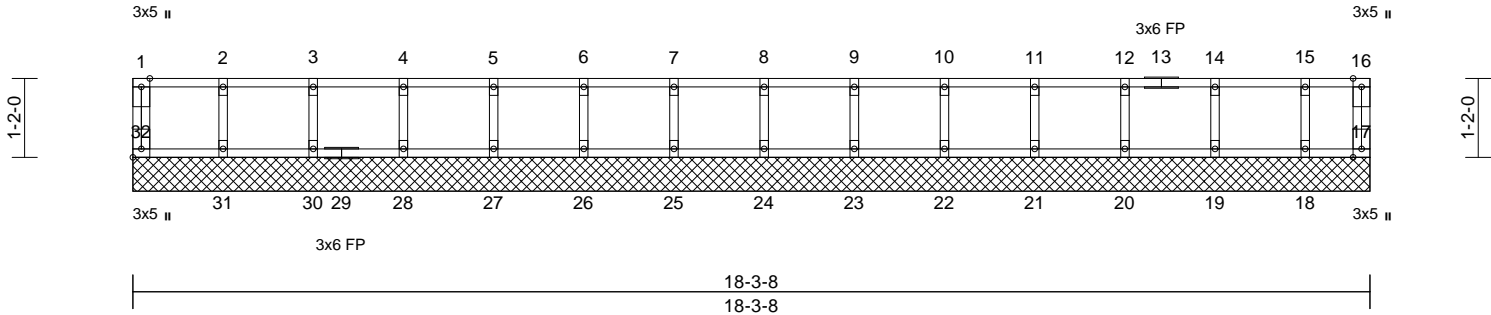

Scale = 1:34.1

Plate Offsets (X, Y): [32:Edge,0-1-8]

Loading	(psf)	Spacing	2-0-0	CSI	DEFL	in	(loc)	l/defl	L/d	PLATES	GRIP
TCLL	40.0	Plate Grip DOL	1.00	TC	Vert(LL)	n/a	-	n/a	999	MT20	244/190
TCDL	10.0	Lumber DOL	1.00	BC	Vert(TL)	n/a	-	n/a	999		
BCLL	0.0	Rep Stress Incr	YES	WB	Horiz(TL)	0.00	17	n/a	n/a		
BCDL	5.0	Code	IRC2021/TPI2014	Matrix-MR						Weight: 78 lb	FT = 20%F, 11%E

**LUMBER**

TOP CHORD 2x4 SP No.2(flat)  
BOT CHORD 2x4 SP No.2(flat)  
WEBS 2x4 SP No.3(flat)  
OTHERS 2x4 SP No.3(flat)

**BRACING**

TOP CHORD Structural wood sheathing directly applied or 6-0-0 oc purlins, except end verticals.  
BOT CHORD Rigid ceiling directly applied or 10-0-0 oc bracing.

**REACTIONS** (size) 17=18-3-8, 18=18-3-8, 19=18-3-8, 20=18-3-8, 21=18-3-8, 22=18-3-8, 23=18-3-8, 24=18-3-8, 25=18-3-8, 26=18-3-8, 27=18-3-8, 28=18-3-8, 30=18-3-8, 31=18-3-8, 32=18-3-8  
Max Grav 17=40 (LC 1), 18=120 (LC 1), 19=152 (LC 1), 20=145 (LC 1), 21=147 (LC 1), 22=147 (LC 1), 23=147 (LC 1), 24=147 (LC 1), 25=147 (LC 1), 26=147 (LC 1), 27=147 (LC 1), 28=147 (LC 1), 30=147 (LC 1), 31=147 (LC 1), 32=59 (LC 1)

**FORCES** (lb) - Maximum Compression/Maximum Tension

TOP CHORD 1-32=-55/0, 16-17=-34/0, 1-2=-7/0, 2-3=-7/0, 3-4=-7/0, 4-5=-7/0, 5-6=-7/0, 6-7=-7/0, 7-8=-7/0, 8-9=-7/0, 9-10=-7/0, 10-11=-7/0, 11-12=-7/0, 12-14=-7/0, 14-15=-7/0, 15-16=-7/0  
BOT CHORD 31-32=0/7, 30-31=0/7, 28-30=0/7, 27-28=0/7, 26-27=0/7, 25-26=0/7, 24-25=0/7, 23-24=0/7, 22-23=0/7, 21-22=0/7, 20-21=0/7, 19-20=0/7, 18-19=0/7, 17-18=0/7  
WEBS 2-31=-132/0, 3-30=-134/0, 4-28=-133/0, 5-27=-133/0, 6-26=-133/0, 7-25=-133/0, 8-24=-133/0, 9-23=-133/0, 10-22=-133/0, 11-21=-134/0, 12-20=-132/0, 14-19=-138/0, 15-18=-112/0

**NOTES**

- 1) All plates are 1.5x3 MT20 unless otherwise indicated.
- 2) Gable requires continuous bottom chord bearing.
- 3) Truss to be fully sheathed from one face or securely braced against lateral movement (i.e. diagonal web).
- 4) Gable studs spaced at 1-4-0 oc.
- 5) Recommend 2x6 strongbacks, on edge, spaced at 10-00-00 oc and fastened to each truss with 3-10d (0.131" X 3") nails. Strongbacks to be attached to walls at their outer ends or restrained by other means.

**LOAD CASE(S)** Standard



January 13, 2025

**WARNING - Verify design parameters and READ NOTES ON THIS AND INCLUDED MITEK REFERENCE PAGE MII-7473 rev. 1/2/2023 BEFORE USE.**

Design valid for use only with MiTek® connectors. This design is based only upon parameters shown, and is for an individual building component, not a truss system. Before use, the building designer must verify the applicability of design parameters and properly incorporate this design into the overall building design. Bracing indicated is to prevent buckling of individual truss web and/or chord members only. Additional temporary and permanent bracing is always required for stability and to prevent collapse with possible personal injury and property damage. For general guidance regarding the fabrication, storage, delivery, erection and bracing of trusses and truss systems, see **ANSI/TP1 Quality Criteria and DSB-22** available from Truss Plate Institute (www.tpinst.org) and **BCSI Building Component Safety Information** available from the Structural Building Component Association (www.sbcacomponents.com)



818 Soundside Road  
Edenton, NC 27932

Job 25010029-A	Truss FW12	Truss Type Floor Supported Gable	Qty 1	Ply 1	132 Hidden Lakes North-2nd Floor-Plan 10 GRH I70703738 Job Reference (optional)
-------------------	---------------	-------------------------------------	----------	----------	---

Carter Components (Sanford, NC), Sanford, NC - 27332,

Run: 8.73 S Dec 5 2024 Print: 8.730 S Dec 5 2024 MiTek Industries, Inc. Sun Jan 12 16:05:45  
ID:JlZmJgdSQw3xWhEqC48OzkzwhrO-RfC?PsB70Hq3NSgPqnL8w3uITXbGKWrCD0i7J4zJC?f

Page: 1

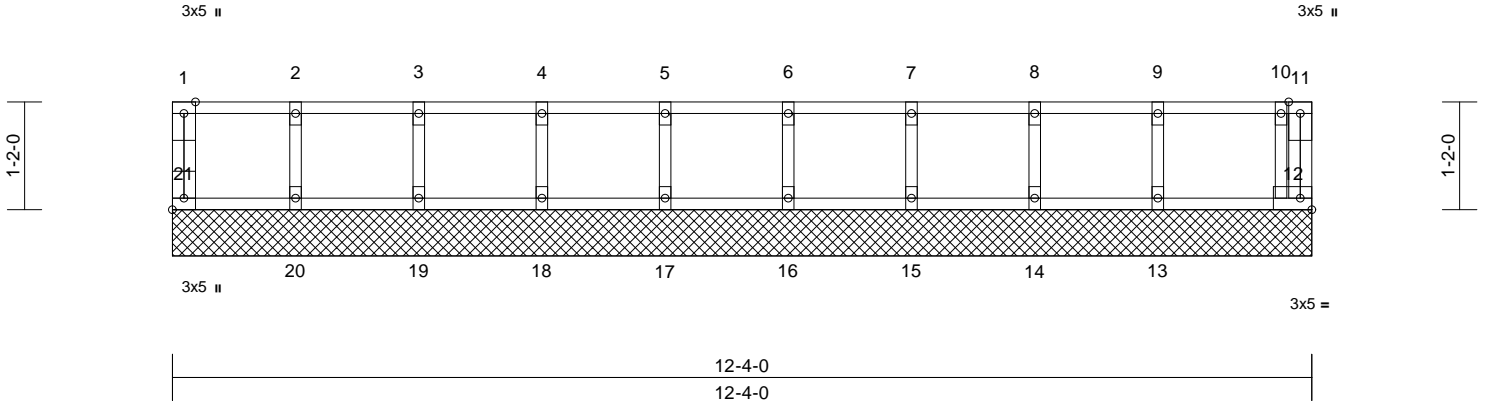

Scale = 1:24.9

Plate Offsets (X, Y): [21:Edge,0-1-8]

Loading	(psf)	Spacing	2-0-0	CSI	DEFL	in	(loc)	l/defl	L/d	PLATES	GRIP	
TCLL	40.0	Plate Grip DOL	1.00	TC	0.08	Vert(LL)	n/a	-	n/a	999	MT20	244/190
TCDL	10.0	Lumber DOL	1.00	BC	0.02	Vert(TL)	n/a	-	n/a	999		
BCLL	0.0	Rep Stress Incr	YES	WB	0.03	Horiz(TL)	0.00	12	n/a	n/a		
BCDL	5.0	Code	IRC2021/TPI2014	Matrix-MR							Weight: 54 lb	FT = 20%F, 11%E

**LUMBER**

TOP CHORD 2x4 SP No.2(flat)  
 BOT CHORD 2x4 SP No.2(flat)  
 WEBS 2x4 SP No.3(flat)  
 OTHERS 2x4 SP No.3(flat)

5) Recommend 2x6 strongbacks, on edge, spaced at 10-00-00 oc and fastened to each truss with 3-10d (0.131" X 3") nails. Strongbacks to be attached to walls at their outer ends or restrained by other means.

**LOAD CASE(S)** Standard

**BRACING**

TOP CHORD Structural wood sheathing directly applied or 6-0-0 oc purlins, except end verticals.  
 BOT CHORD Rigid ceiling directly applied or 10-0-0 oc bracing.

**REACTIONS** (size)

12=12-4-0, 13=12-4-0, 14=12-4-0,  
 15=12-4-0, 16=12-4-0, 17=12-4-0,  
 18=12-4-0, 19=12-4-0, 20=12-4-0,  
 21=12-4-0  
 Max Grav 12=86 (LC 1), 13=159 (LC 1),  
 14=143 (LC 1), 15=148 (LC 1),  
 16=146 (LC 1), 17=147 (LC 1),  
 18=146 (LC 1), 19=149 (LC 1),  
 20=136 (LC 1), 21=68 (LC 1)

**FORCES** (lb) - Maximum Compression/Maximum Tension

TOP CHORD 1-21=-59/0, 11-12=0/13, 1-2=-15/0,  
 2-3=-15/0, 3-4=-15/0, 4-5=-15/0, 5-6=-15/0,  
 6-7=-15/0, 7-8=-15/0, 8-9=-15/0, 9-10=-15/0,  
 10-11=-3/0  
 BOT CHORD 20-21=0/15, 19-20=0/15, 18-19=0/15,  
 17-18=0/15, 16-17=0/15, 15-16=0/15,  
 14-15=0/15, 13-14=0/15, 12-13=0/15  
 WEBS 2-20=-127/0, 3-19=-135/0, 4-18=-133/0,  
 5-17=-133/0, 6-16=-133/0, 7-15=-134/0,  
 8-14=-131/0, 9-13=-142/0, 10-12=-94/0

**NOTES**

- All plates are 1.5x3 MT20 unless otherwise indicated.
- Gable requires continuous bottom chord bearing.
- Truss to be fully sheathed from one face or securely braced against lateral movement (i.e. diagonal web).
- Gable studs spaced at 1-4-0 oc.

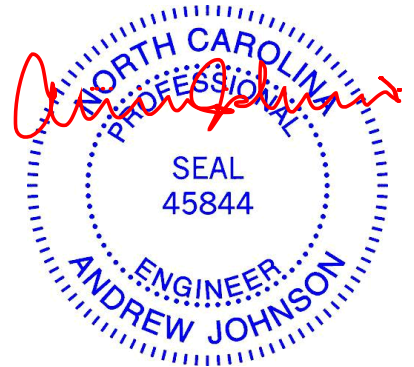

January 13, 2025

**WARNING - Verify design parameters and READ NOTES ON THIS AND INCLUDED MITEK REFERENCE PAGE MII-7473 rev. 1/2/2023 BEFORE USE.**

Design valid for use only with MiTek® connectors. This design is based only upon parameters shown, and is for an individual building component, not a truss system. Before use, the building designer must verify the applicability of design parameters and properly incorporate this design into the overall building design. Bracing indicated is to prevent buckling of individual truss web and/or chord members only. Additional temporary and permanent bracing is always required for stability and to prevent collapse with possible personal injury and property damage. For general guidance regarding the fabrication, storage, delivery, erection and bracing of trusses and truss systems, see **ANSI/TPH Quality Criteria and DSB-22** available from Truss Plate Institute (www.tpinst.org) and **BCSI Building Component Safety Information** available from the Structural Building Component Association (www.sbcacomponents.com)



818 Soundside Road  
 Edenton, NC 27932

Job 25010029-A	Truss FW09	Truss Type Floor Supported Gable	Qty 1	Ply 1	132 Hidden Lakes North-2nd Floor-Plan 10 GRH I70703739 Job Reference (optional)
-------------------	---------------	-------------------------------------	----------	----------	---

Carter Components (Sanford, NC), Sanford, NC - 27332,

Run: 8.73 S Dec 5 2024 Print: 8.730 S Dec 5 2024 MiTek Industries, Inc. Sun Jan 12 16:05:44  
ID:vAtehba7?hMFDVFXyahL5zwhrR-RfC?PsB70Hq3NSgPqnL8w3ulTXbGKWrcDoi7J4zJC?f

Page: 1

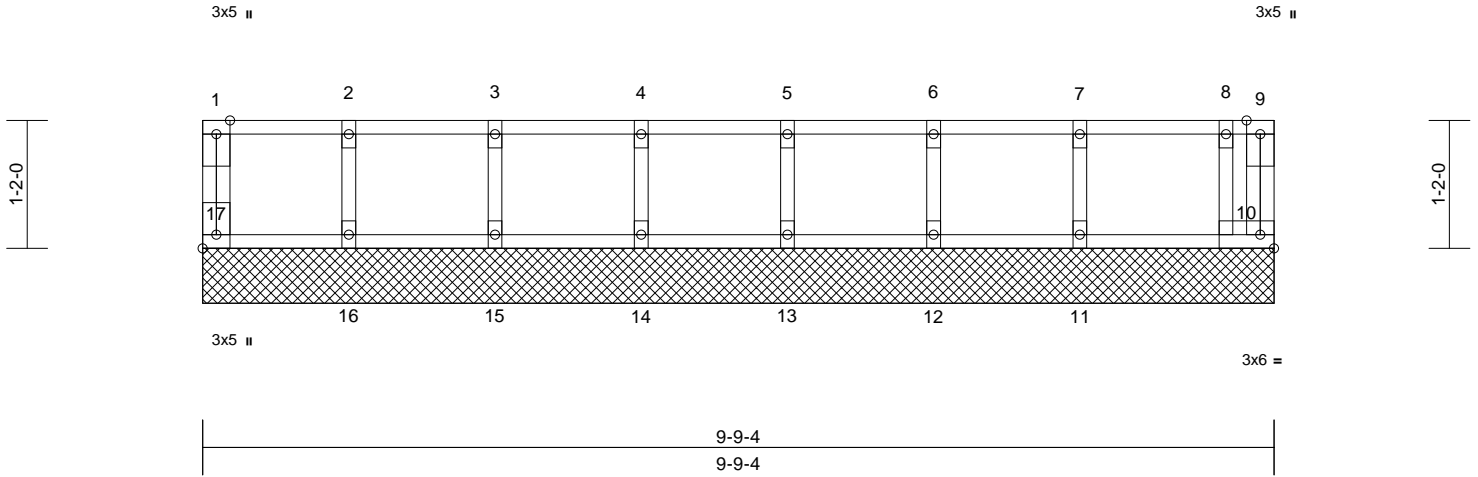

Scale = 1:21

Plate Offsets (X, Y): [17:Edge,0-1-8]

Loading	(psf)	Spacing	2-0-0	CSI	DEFL	in	(loc)	l/defl	L/d	PLATES	GRIP	
TCLL	40.0	Plate Grip DOL	1.00	TC	0.09	Vert(LL)	n/a	-	n/a	999	MT20	244/190
TCDL	10.0	Lumber DOL	1.00	BC	0.03	Vert(TL)	n/a	-	n/a	999		
BCLL	0.0	Rep Stress Incr	YES	WB	0.03	Horiz(TL)	0.00	10	n/a	n/a		
BCDL	5.0	Code	IRC2021/TPI2014	Matrix-MR							Weight: 44 lb	FT = 20%F, 11%E

**LUMBER**

TOP CHORD 2x4 SP No.2(flat)  
BOT CHORD 2x4 SP No.2(flat)  
WEBS 2x4 SP No.3(flat)  
OTHERS 2x4 SP No.3(flat)

**LOAD CASE(S)** Standard

**BRACING**

TOP CHORD Structural wood sheathing directly applied or 6-0-0 oc purlins, except end verticals.  
BOT CHORD Rigid ceiling directly applied or 10-0-0 oc bracing.

**REACTIONS** (size) 10=9-9-4, 11=9-9-4, 12=9-9-4, 13=9-9-4, 14=9-9-4, 15=9-9-4, 16=9-9-4, 17=9-9-4  
Max Grav 10=95 (LC 1), 11=161 (LC 1), 12=143 (LC 1), 13=148 (LC 1), 14=146 (LC 1), 15=150 (LC 1), 16=134 (LC 1), 17=70 (LC 1)

**FORCES** (lb) - Maximum Compression/Maximum Tension

TOP CHORD 1-17=-60/0, 9-10=0/4, 1-2=-17/0, 2-3=-17/0, 3-4=-17/0, 4-5=-17/0, 5-6=-17/0, 6-7=-17/0, 7-8=-17/0, 8-9=0/0  
BOT CHORD 16-17=0/17, 15-16=0/17, 14-15=0/17, 13-14=0/17, 12-13=0/17, 11-12=0/17, 10-11=0/17  
WEBS 2-16=-126/0, 3-15=-135/0, 4-14=-133/0, 5-13=-134/0, 6-12=-131/0, 7-11=-143/0, 8-10=-96/0

**NOTES**

- All plates are 1.5x3 MT20 unless otherwise indicated.
- Gable requires continuous bottom chord bearing.
- Truss to be fully sheathed from one face or securely braced against lateral movement (i.e. diagonal web).
- Gable studs spaced at 1-4-0 oc.
- Recommend 2x6 strongbacks, on edge, spaced at 10-00-00 oc and fastened to each truss with 3-10d (0.131" X 3") nails. Strongbacks to be attached to walls at their outer ends or restrained by other means.



January 13, 2025

**WARNING - Verify design parameters and READ NOTES ON THIS AND INCLUDED MITEK REFERENCE PAGE MII-7473 rev. 1/2/2023 BEFORE USE.**

Design valid for use only with MiTek® connectors. This design is based only upon parameters shown, and is for an individual building component, not a truss system. Before use, the building designer must verify the applicability of design parameters and properly incorporate this design into the overall building design. Bracing indicated is to prevent buckling of individual truss web and/or chord members only. Additional temporary and permanent bracing is always required for stability and to prevent collapse with possible personal injury and property damage. For general guidance regarding the fabrication, storage, delivery, erection and bracing of trusses and truss systems, see **ANSI/TPH Quality Criteria and DSB-22** available from Truss Plate Institute (www.tpinst.org) and **BCSI Building Component Safety Information** available from the Structural Building Component Association (www.sbcacomponents.com)



818 Soundside Road  
Edenton, NC 27932



Job 25010029-A	Truss F11	Truss Type Floor	Qty 8	Ply 1	132 Hidden Lakes North-2nd Floor-Plan 10 GRH I70703740 Job Reference (optional)
-------------------	--------------	---------------------	----------	----------	---

Carter Components (Sanford, NC), Sanford, NC - 27332,

Run: 8.73 S Dec 5 2024 Print: 8.730 S Dec 5 2024 MiTek Industries, Inc. Sun Jan 12 16:05:44  
ID:4Cx4j9vpZUWSJTelhU3KX4zwhsK-RfC?PsB70Hq3NSgPqnL8w3ulTXbGKWrCDoi7J4zJC?f

Page: 1

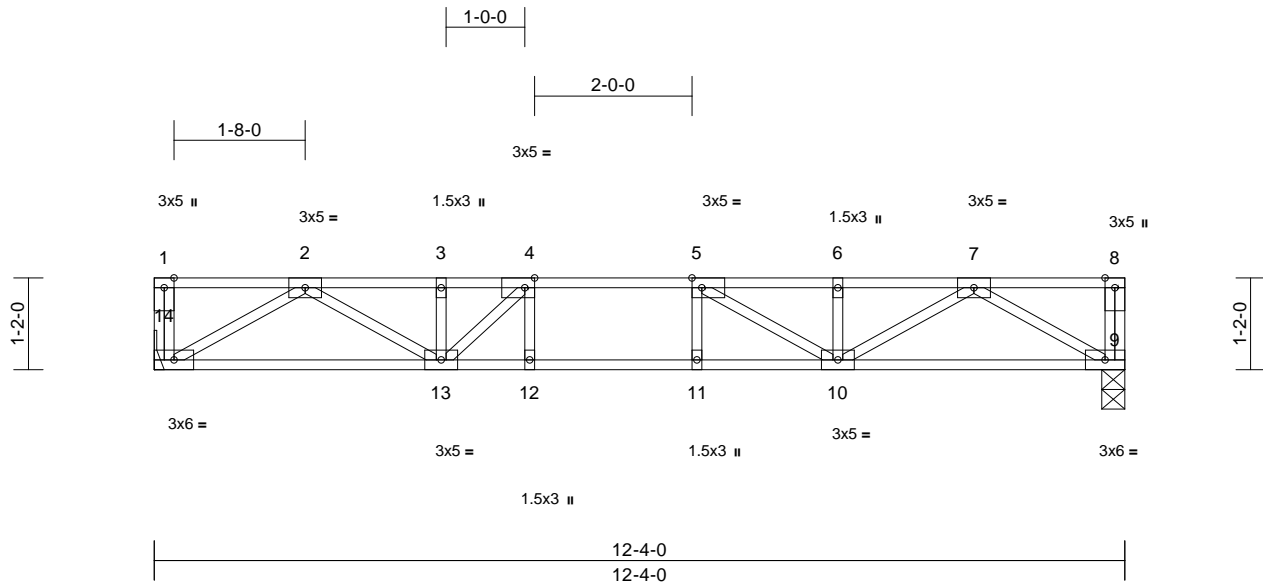

Scale = 1:29.3

Plate Offsets (X, Y): [4:0-1-8,Edge], [5:0-1-8,Edge]

Loading	(psf)	Spacing	1-4-0	CSI	DEFL	in	(loc)	l/defl	L/d	PLATES	GRIP	
TCLL	40.0	Plate Grip DOL	1.00	TC	0.34	Vert(LL)	-0.07	10-11	>999	480	MT20	244/190
TCDL	10.0	Lumber DOL	1.00	BC	0.52	Vert(CT)	-0.10	10-11	>999	360		
BCLL	0.0	Rep Stress Incr	YES	WB	0.23	Horz(CT)	0.02	9	n/a	n/a		
BCDL	5.0	Code	IRC2021/TPI2014	Matrix-MSH							Weight: 64 lb	FT = 20%F, 11%E

**LUMBER**

TOP CHORD 2x4 SP No.2(flat)  
BOT CHORD 2x4 SP No.2(flat)  
WEBS 2x4 SP No.3(flat)

**BRACING**

TOP CHORD Structural wood sheathing directly applied or 6-0-0 oc purlins, except end verticals.  
BOT CHORD Rigid ceiling directly applied or 10-0-0 oc bracing.

**REACTIONS** (size) 9=0-3-8, 14= Mechanical  
Max Grav 9=443 (LC 1), 14=443 (LC 1)

**FORCES** (lb) - Maximum Compression/Maximum Tension

TOP CHORD 1-14=-48/0, 8-9=-50/0, 1-2=0/0, 2-3=-1065/0, 3-4=-1065/0, 4-5=-1258/0, 5-6=-1081/0, 6-7=-1081/0, 7-8=0/0

BOT CHORD 13-14=0/662, 12-13=0/1258, 11-12=0/1258, 10-11=0/1258, 9-10=0/661

WEBS 7-9=-764/0, 2-14=-765/0, 7-10=0/491, 2-13=0/471, 6-10=-140/7, 3-13=-100/54, 5-10=-330/0, 4-13=-380/0, 4-12=-36/83, 5-11=-51/41

**NOTES**

- 1) Unbalanced floor live loads have been considered for this design.
- 2) All plates are 3x5 MT20 unless otherwise indicated.
- 3) Refer to girder(s) for truss to truss connections.
- 4) Recommend 2x6 strongbacks, on edge, spaced at 10-00-00 oc and fastened to each truss with 3-10d (0.131" X 3") nails. Strongbacks to be attached to walls at their outer ends or restrained by other means.

**LOAD CASE(S)** Standard



January 13, 2025

**WARNING - Verify design parameters and READ NOTES ON THIS AND INCLUDED MITEK REFERENCE PAGE MII-7473 rev. 1/2/2023 BEFORE USE.**

Design valid for use only with MiTek® connectors. This design is based only upon parameters shown, and is for an individual building component, not a truss system. Before use, the building designer must verify the applicability of design parameters and properly incorporate this design into the overall building design. Bracing indicated is to prevent buckling of individual truss web and/or chord members only. Additional temporary and permanent bracing is always required for stability and to prevent collapse with possible personal injury and property damage. For general guidance regarding the fabrication, storage, delivery, erection and bracing of trusses and truss systems, see **ANSI/TPI1 Quality Criteria and DSB-22** available from Truss Plate Institute ([www.tpinst.org](http://www.tpinst.org)) and **BCSI Building Component Safety Information** available from the Structural Building Component Association ([www.sbcacomponents.com](http://www.sbcacomponents.com))

ENGINEERING BY  
**TRENCO**  
A MiTek Affiliate

818 Soundside Road  
Edenton, NC 27932

Job 25010029-A	Truss F10	Truss Type Floor	Qty 8	Ply 1	132 Hidden Lakes North-2nd Floor-Plan 10 GRH 170703741 Job Reference (optional)
-------------------	--------------	---------------------	----------	----------	---

Carter Components (Sanford, NC), Sanford, NC - 27332,

Run: 8.73 S Dec 5 2024 Print: 8.730 S Dec 5 2024 MiTek Industries, Inc. Sun Jan 12 16:05:44  
ID:qaCisOMXi9NcyoshBbmJL5zwhuK-RfC?PsB70Hq3NSgPqnL8w3uITXbGKWrCDoi7J4zJC?f

Page: 1

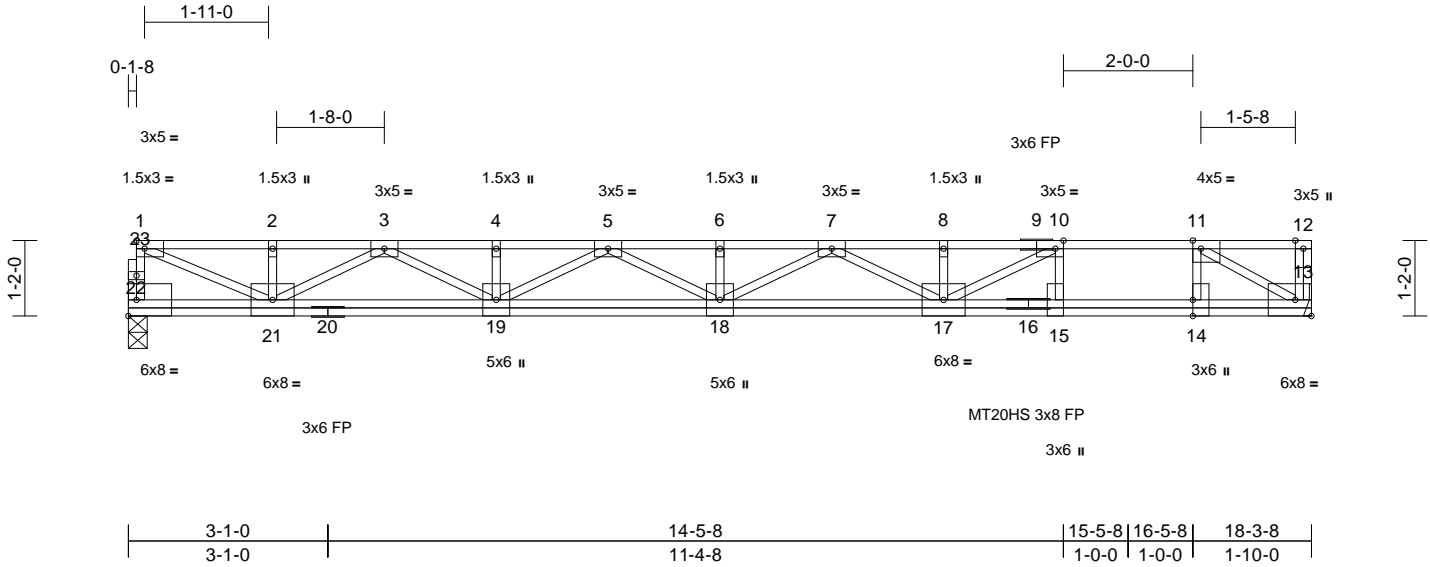

Scale = 1:35.6

Plate Offsets (X, Y): [10:0-1-8,Edge], [11:0-1-8,Edge], [14:0-3-0,Edge]

Loading	(psf)	Spacing	1-4-0	CSI	DEFL	in	(loc)	l/defl	L/d	PLATES	GRIP	
TCLL	40.0	Plate Grip DOL	1.00	TC	0.66	Vert(LL)	-0.28	17-18	>774	480	MT20	244/190
TCDL	10.0	Lumber DOL	1.00	BC	0.79	Vert(CT)	-0.38	17-18	>562	360	MT20HS	187/143
BCLL	0.0	Rep Stress Incr	YES	WB	0.64	Horz(CT)	0.03	13	n/a	n/a		
BCDL	5.0	Code	IRC2021/TPI2014	Matrix-MSH								
											Weight: 118 lb	FT = 20%F, 11%E

**LUMBER**

- TOP CHORD 2x4 SP No.2(flat)
- BOT CHORD 2x4 SP No.2(flat) \*Except\* 20-13,16-13:2x4 SP No.1(flat)
- WEBS 2x4 SP No.3(flat)
- OTHERS 2x4 SP No.3(flat)

**BRACING**

- TOP CHORD Structural wood sheathing directly applied or 6-0-0 oc purlins, except end verticals.
- BOT CHORD Rigid ceiling directly applied or 10-0-0 oc bracing.

**REACTIONS** (size) 13= Mechanical, 22=0-3-8  
Max Grav 13=662 (LC 1), 22=657 (LC 1)

- FORCES** (lb) - Maximum Compression/Maximum Tension
- TOP CHORD 1-22=-644/0, 12-13=-24/45, 1-2=-1260/0, 2-3=-1260/0, 3-4=-2588/0, 4-5=-2588/0, 5-6=-3009/0, 6-7=-3009/0, 7-8=-2660/0, 8-10=-2660/0, 10-11=-1523/0, 11-12=0/0
  - BOT CHORD 21-22=0/41, 19-21=0/2026, 18-19=0/2911, 17-18=0/2933, 15-17=0/1523, 14-15=0/1523, 13-14=0/1523
  - WEBS 10-15=-644/0, 11-14=0/659, 10-17=0/1313, 8-17=-170/0, 7-17=-321/0, 7-18=-14/95, 6-18=-105/0, 5-18=0/113, 5-19=-371/0, 4-19=-105/0, 3-19=0/645, 3-21=-881/0, 2-21=-139/0, 1-21=0/1352, 11-13=-1772/0

**NOTES**

- Unbalanced floor live loads have been considered for this design.
- All plates are MT20 plates unless otherwise indicated.
- Refer to girder(s) for truss to truss connections.
- Recommend 2x6 strongbacks, on edge, spaced at 10-00-00 oc and fastened to each truss with 3-10d (0.131" X 3") nails. Strongbacks to be attached to walls at their outer ends or restrained by other means.
- CAUTION, Do not erect truss backwards.

**LOAD CASE(S)** Standard



January 13, 2025

**WARNING - Verify design parameters and READ NOTES ON THIS AND INCLUDED MITEK REFERENCE PAGE MII-7473 rev. 1/2/2023 BEFORE USE.**

Design valid for use only with MiTek® connectors. This design is based only upon parameters shown, and is for an individual building component, not a truss system. Before use, the building designer must verify the applicability of design parameters and properly incorporate this design into the overall building design. Bracing indicated is to prevent buckling of individual truss web and/or chord members only. Additional temporary and permanent bracing is always required for stability and to prevent collapse with possible personal injury and property damage. For general guidance regarding the fabrication, storage, delivery, erection and bracing of trusses and truss systems, see **ANSI/TP1 Quality Criteria and DSB-22** available from Truss Plate Institute (www.tpinst.org) and **BCSI Building Component Safety Information** available from the Structural Building Component Association (www.sbccomponents.com)



818 Soundside Road  
Edenton, NC 27932

Job 25010029-A	Truss F09	Truss Type Floor	Qty 1	Ply 1	132 Hidden Lakes North-2nd Floor-Plan 10 GRH 170703742 Job Reference (optional)
-------------------	--------------	---------------------	----------	----------	---

Carter Components (Sanford, NC), Sanford, NC - 27332,

Run: 8.73 S Dec 5 2024 Print: 8.730 S Dec 5 2024 MiTek Industries, Inc. Sun Jan 12 16:05:44  
ID:twYwTv7cAK\_JAtv1a6ws44zhud-RfC?PsB70Hq3NSgPqnL8w3uTXbGKwRCDoi7J4zJC?f

Page: 1

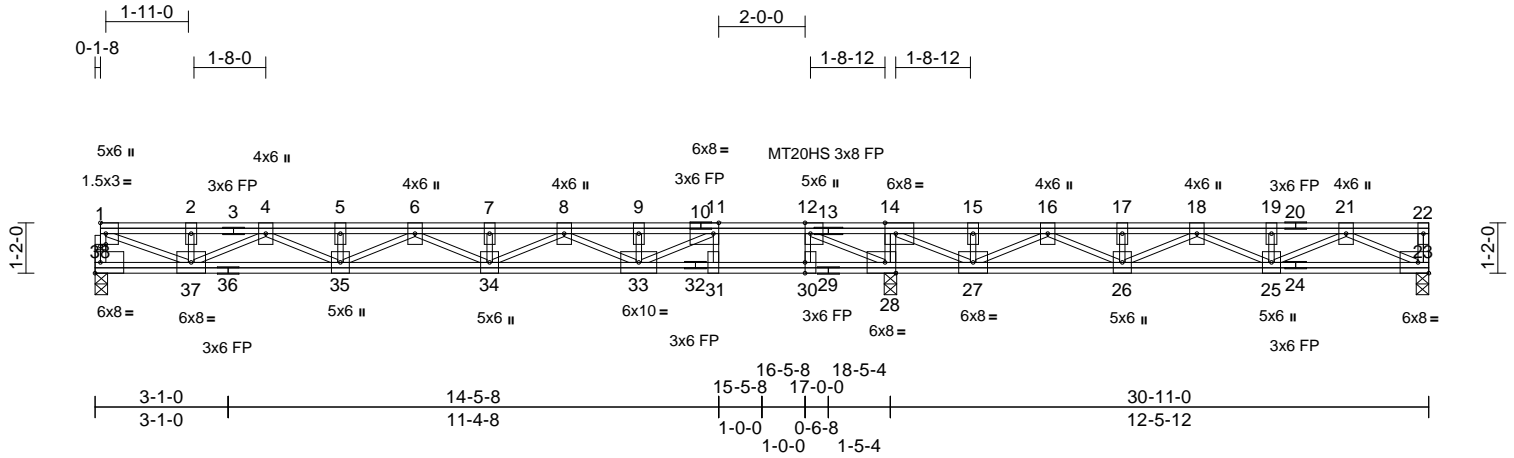

Scale = 1:53.4

Plate Offsets (X, Y): [1:0-1-8,0-0-8], [11:0-1-8,Edge], [12:0-3-0,Edge], [14:0-3-0,Edge], [28:0-3-0,Edge], [30:0-3-0,Edge]

Loading	(psf)	Spacing	1-4-0	CSI	DEFL	in	(loc)	l/defl	L/d	PLATES	GRIP	
TCLL	40.0	Plate Grip DOL	1.00	TC	0.80	Vert(LL)	-0.20	33-34	>999	480	MT20	244/190
TCDL	10.0	Lumber DOL	1.00	BC	0.67	Vert(CT)	-0.27	33-34	>827	360	MT20HS	187/143
BCLL	0.0	Rep Stress Incr	YES	WB	0.83	Horz(CT)	0.02	28	n/a	n/a		
BCDL	5.0	Code	IRC2021/TPI2014	Matrix-MSH								
											Weight: 242 lb	FT = 20%F, 11%E

**LUMBER**

- TOP CHORD 2x4 SP No.2(flat)
- BOT CHORD 2x4 SP No.2(flat)
- WEBS 2x4 SP No.3(flat)
- OTHERS 2x4 SP No.3(flat)

**BRACING**

- TOP CHORD Structural wood sheathing directly applied or 6-0-0 oc purlins, except end verticals.
- BOT CHORD Rigid ceiling directly applied or 6-0-0 oc bracing.

- REACTIONS** (size) 23=0-3-8, 28=0-3-8, 38=0-3-8  
Max Grav 23=384 (LC 4), 28=1367 (LC 1), 38=593 (LC 3)

**FORCES** (lb) - Maximum Compression/Maximum Tension

- TOP CHORD  
1-38=-581/0, 22-23=-52/0, 1-2=-1184/0,  
2-4=-1184/0, 4-5=-2350/0, 5-6=-2350/0,  
6-7=-2557/0, 7-8=-2557/0, 8-9=-1948/0,  
9-11=-1948/0, 11-12=-479/289,  
12-14=0/1936, 14-15=-27/1069,  
15-16=-27/1069, 16-17=-979/457,  
17-18=-979/457, 18-19=-981/93,  
19-21=-981/93, 21-22=0/0
- BOT CHORD  
37-38=0/0, 35-37=0/1874, 34-35=0/2562,  
33-34=0/2315, 31-33=-289/479,  
30-31=-289/479, 28-30=-289/479,  
27-28=-1936/0, 26-27=-742/615,  
25-26=-252/1093, 23-25=-22/625
- WEBS  
11-31=-450/0, 12-30=0/440, 14-28=-532/0,  
12-28=-2311/0, 21-23=-702/24,  
21-25=-81/403, 19-25=-107/0,  
18-25=-126/179, 18-26=-289/0, 17-26=-111/0,  
16-26=0/572, 16-27=-818/0, 15-27=-138/0,  
14-27=0/1249, 11-33=0/1738, 9-33=-357/0,  
8-33=-456/0, 8-34=0/320, 7-34=-123/0,  
6-34=-53/0, 6-35=-240/0, 5-35=-112/0,  
4-35=0/539, 4-37=-781/0, 2-37=-126/0,  
1-37=0/1286

**NOTES**

- 1) Unbalanced floor live loads have been considered for this design.
- 2) All plates are MT20 plates unless otherwise indicated.
- 3) All plates are 3x6 MT20 unless otherwise indicated.
- 4) Recommend 2x6 strongbacks, on edge, spaced at 10-00-00 oc and fastened to each truss with 3-10d (0.131" X 3") nails. Strongbacks to be attached to walls at their outer ends or restrained by other means.
- 5) CAUTION, Do not erect truss backwards.

**LOAD CASE(S)** Standard



January 13, 2025

**WARNING - Verify design parameters and READ NOTES ON THIS AND INCLUDED MITEK REFERENCE PAGE MII-7473 rev. 1/2/2023 BEFORE USE.**

Design valid for use only with MiTek® connectors. This design is based only upon parameters shown, and is for an individual building component, not a truss system. Before use, the building designer must verify the applicability of design parameters and properly incorporate this design into the overall building design. Bracing indicated is to prevent buckling of individual truss web and/or chord members only. Additional temporary and permanent bracing is always required for stability and to prevent collapse with possible personal injury and property damage. For general guidance regarding the fabrication, storage, delivery, erection and bracing of trusses and truss systems, see **ANSI/TPI Quality Criteria and DSB-22** available from Truss Plate Institute (www.tpinst.org) and **BCSI Building Component Safety Information** available from the Structural Building Component Association (www.sbcacomponents.com)



818 Soundside Road  
Edenton, NC 27932

Job 25010029-A	Truss F08	Truss Type Floor	Qty 1	Ply 1	132 Hidden Lakes North-2nd Floor-Plan 10 GRH 170703743 Job Reference (optional)
-------------------	--------------	---------------------	----------	----------	---

Carter Components (Sanford, NC), Sanford, NC - 27332,

Run: 8.73 S Dec 5 2024 Print: 8.730 S Dec 5 2024 MiTek Industries, Inc. Sun Jan 12 16:05:44  
ID:NVfkGjHBti75JVbzJuivzwhv9-RfC?PsB70Hq3NSgPqnL8w3uTXbGKWrCDoi7J4zJC?f

Page: 1

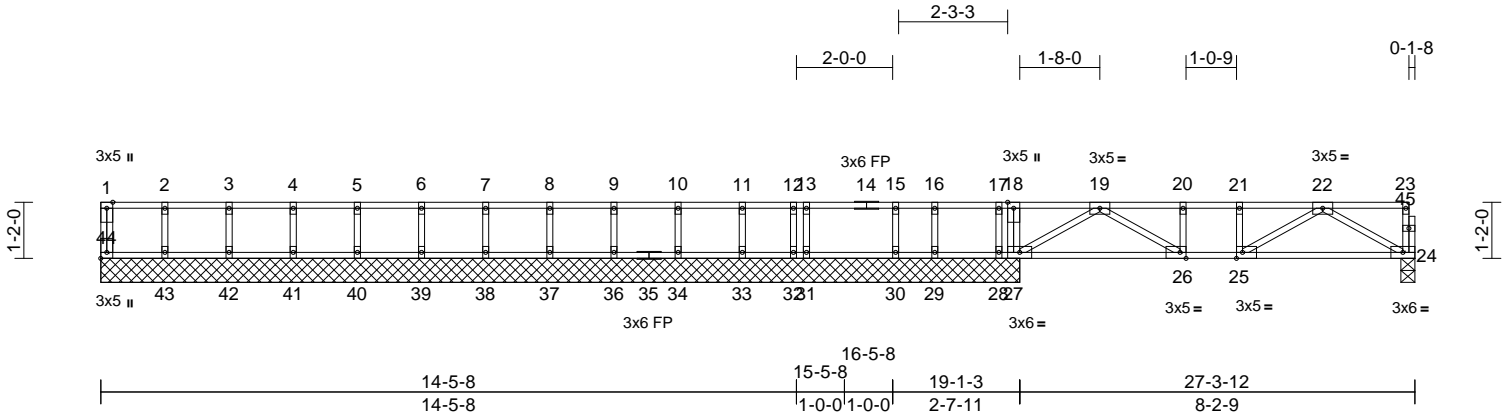

Scale = 1:47.9

Plate Offsets (X, Y): [25:0-1-8,Edge], [26:0-1-8,Edge], [44:Edge,0-1-8]

Loading	(psf)	Spacing	2-0-0	CSI	DEFL	in	(loc)	l/defl	L/d	PLATES	GRIP	
TCLL	40.0	Plate Grip DOL	1.00	TC	0.17	Vert(LL)	-0.02	25-26	>999	480	MT20	244/190
TCDL	10.0	Lumber DOL	1.00	BC	0.25	Vert(CT)	-0.04	24-25	>999	360		
BCLL	0.0	Rep Stress Incr	YES	WB	0.17	Horz(CT)	0.01	24	n/a	n/a		
BCDL	5.0	Code	IRC2021/TPI2014	Matrix-MSH								
											Weight: 123 lb	FT = 20%F, 11%E

LUMBER	
TOP CHORD	2x4 SP No.2(flat)
BOT CHORD	2x4 SP No.2(flat)
WEBS	2x4 SP No.3(flat)
OTHERS	2x4 SP No.3(flat)

BOT CHORD	
	43-44=0/0, 42-43=0/0, 41-42=0/0, 40-41=0/0, 39-40=0/0, 38-39=0/0, 37-38=0/0, 36-37=0/0, 34-36=0/0, 33-34=0/0, 32-33=0/0, 31-32=0/0, 30-31=0/0, 29-30=0/0, 28-29=0/0, 27-28=0/0, 26-27=0/585, 25-26=0/865, 24-25=0/615
WEBS	
	12-32=0/12, 15-30=147/0, 18-27=-205/0, 19-27=-677/0, 22-24=-707/0, 19-26=0/327, 22-25=0/292, 20-26=-152/0, 21-25=-123/0, 2-43=-142/0, 3-42=-131/0, 4-41=-134/0, 5-40=-133/0, 6-39=-133/0, 7-38=-133/0, 8-37=-134/0, 9-36=-133/0, 10-34=-136/0, 11-33=-124/0, 13-31=-181/0, 16-29=-89/0, 17-28=-103/89

BRACING	
TOP CHORD	Structural wood sheathing directly applied or 6-0-0 oc purlins, except end verticals.
BOT CHORD	Rigid ceiling directly applied or 10-0-0 oc bracing.

REACTIONS	(size)	
		24=0-3-8, 27=19-1-3, 28=19-1-3, 29=19-1-3, 30=19-1-3, 31=19-1-3, 32=19-1-3, 33=19-1-3, 34=19-1-3, 36=19-1-3, 37=19-1-3, 38=19-1-3, 39=19-1-3, 40=19-1-3, 41=19-1-3, 42=19-1-3, 43=19-1-3, 44=19-1-3
Max Uplift		28=-141 (LC 4), 32=-16 (LC 1)
Max Grav		24=439 (LC 4), 27=627 (LC 4), 28=70 (LC 3), 29=100 (LC 1), 30=161 (LC 3), 31=202 (LC 1), 32=-6 (LC 4), 33=137 (LC 1), 34=149 (LC 3), 36=146 (LC 1), 37=147 (LC 3), 38=147 (LC 1), 39=147 (LC 1), 40=147 (LC 1), 41=147 (LC 1), 42=145 (LC 1), 43=156 (LC 1), 44=52 (LC 1)

- NOTES**
- 1) Unbalanced floor live loads have been considered for this design.
  - 2) All plates are 1.5x3 MT20 unless otherwise indicated.
  - 3) Truss to be fully sheathed from one face or securely braced against lateral movement (i.e. diagonal web).
  - 4) Gable studs spaced at 1-4-0 oc.
  - 5) One H2.5A Simpson Strong-Tie connectors recommended to connect truss to bearing walls due to UPLIFT at jt(s) 32 and 28. This connection is for uplift only and does not consider lateral forces.
  - 6) Recommend 2x6 strongbacks, on edge, spaced at 10-00-00 oc and fastened to each truss with 3-10d (0.131" X 3") nails. Strongbacks to be attached to walls at their outer ends or restrained by other means.
  - 7) CAUTION, Do not erect truss backwards.
- LOAD CASE(S)** Standard

FORCES	(lb) - Maximum Compression/Maximum Tension
TOP CHORD	1-44=-47/0, 23-24=-68/0, 1-2=0/0, 2-3=0/0, 3-4=0/0, 4-5=0/0, 5-6=0/0, 6-7=0/0, 7-8=0/0, 8-9=0/0, 9-10=0/0, 10-11=0/0, 11-12=0/0, 12-13=0/0, 13-15=0/0, 15-16=0/0, 16-17=0/0, 17-18=0/0, 18-19=0/0, 19-20=-865/0, 20-21=-865/0, 21-22=-865/0, 22-23=-4/0



**WARNING - Verify design parameters and READ NOTES ON THIS AND INCLUDED MITEK REFERENCE PAGE MII-7473 rev. 1/2/2023 BEFORE USE.**  
Design valid for use only with MiTek® connectors. This design is based only upon parameters shown, and is for an individual building component, not a truss system. Before use, the building designer must verify the applicability of design parameters and properly incorporate this design into the overall building design. Bracing indicated is to prevent buckling of individual truss web and/or chord members only. Additional temporary and permanent bracing is always required for stability and to prevent collapse with possible personal injury and property damage. For general guidance regarding the fabrication, storage, delivery, erection and bracing of trusses and truss systems, see **ANSI/TP1 Quality Criteria and DSB-22** available from Truss Plate Institute (www.tpinst.org) and **BCSI Building Component Safety Information** available from the Structural Building Component Association (www.sbcacomponents.com)

ENGINEERING BY  
**TRENCO**  
A MiTek Affiliate  
818 Soundside Road  
Edenton, NC 27932

Job 25010029-A	Truss F07	Truss Type Floor	Qty 3	Ply 1	132 Hidden Lakes North-2nd Floor-Plan 10 GRH I70703744 Job Reference (optional)
-------------------	--------------	---------------------	----------	----------	---

Carter Components (Sanford, NC), Sanford, NC - 27332,

Run: 8.73 S Dec 5 2024 Print: 8.730 S Dec 5 2024 MiTek Industries, Inc. Sun Jan 12 16:05:44  
ID:ZPPSs?OvrOzxBuTYiasKrnwzwhws-RFC?PsB70Hq3NSgPqnL8w3uITXbGKWRcDoi7J4zJC?f

Page: 1

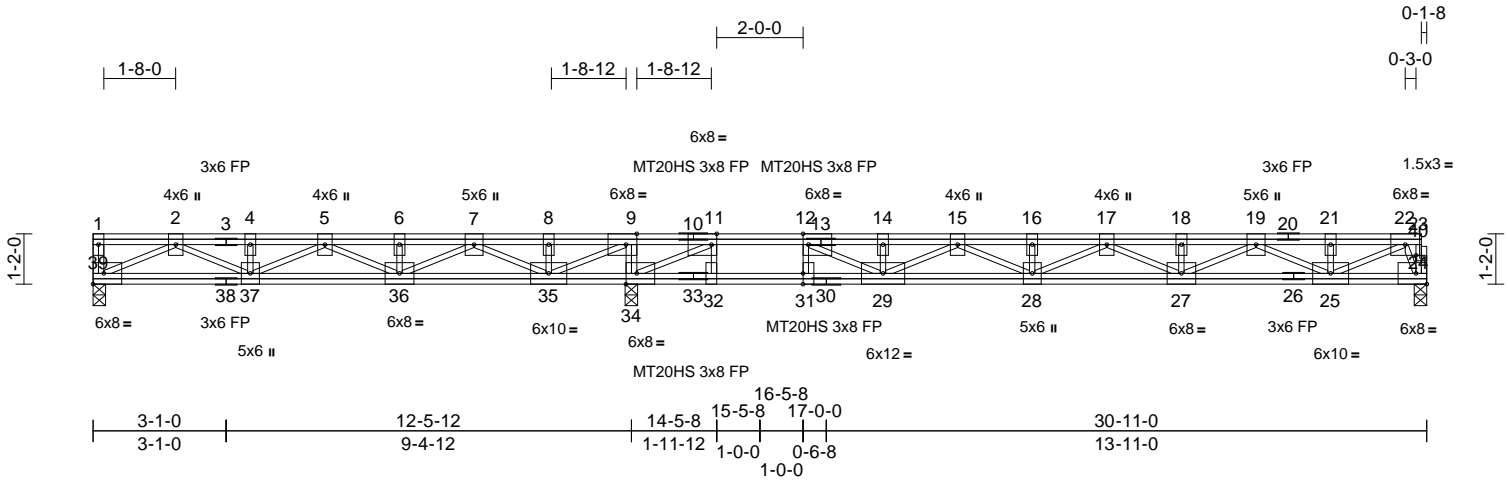

Scale = 1:53.4  
Plate Offsets (X, Y): [9:0-3-0,Edge], [11:0-1-8,Edge], [12:0-1-8,Edge], [31:0-3-0,Edge], [34:0-3-0,Edge], [40:0-1-8,0-0-8]

Loading	(psf)	Spacing	2-0-0	CSI	DEFL	in	(loc)	l/defl	L/d	PLATES	GRIP	
TCLL	40.0	Plate Grip DOL	1.00	TC	0.95	Vert(LL)	-0.28	28-29	>789	480	MT20	244/190
TCDL	10.0	Lumber DOL	1.00	BC	0.94	Vert(CT)	-0.38	28-29	>582	360	MT20HS	187/143
BCLL	0.0	Rep Stress Incr	YES	WB	0.89	Horz(CT)	0.03	24	n/a	n/a		
BCDL	5.0	Code	IRC2021/TPI2014	Matrix-MSH								Weight: 242 lb FT = 20%F, 11%E

**LUMBER**  
TOP CHORD 2x4 SP No.2(flat) \*Except\* 10-20,3-13:2x4 SP No.1(flat)  
BOT CHORD 2x4 SP No.2(flat)  
WEBS 2x4 SP No.3(flat) \*Except\* 29-12:2x4 SP No.2(flat)  
OTHERS 2x4 SP No.3(flat)  
**BRACING**  
TOP CHORD Structural wood sheathing directly applied or 6-0-0 oc purlins, except end verticals.  
BOT CHORD Rigid ceiling directly applied or 6-0-0 oc bracing.  
**REACTIONS** (size) 24=0-3-8, 34=0-3-8, 39=0-3-8  
Max Grav 24=888 (LC 4), 34=2045 (LC 1), 39=576 (LC 3)  
**FORCES** (lb) - Maximum Compression/Maximum Tension  
TOP CHORD 1-39=78/0, 23-24=0/83, 1-2=0/0, 2-4=-1473/133, 4-5=-1473/133, 5-6=-1471/670, 6-7=-1471/670, 7-8=-42/1583, 8-9=-42/1583, 9-11=0/2874, 11-12=-727/435, 12-14=-2926/0, 14-15=-2926/0, 15-16=-3821/0, 16-17=-3821/0, 17-18=-3491/0, 18-19=-3491/0, 19-21=-1722/0, 21-22=-1722/0, 22-23=0/0  
BOT CHORD 37-39=-29/938, 36-37=-366/1639, 35-36=-1094/923, 34-35=-2874/0, 32-34=-435/727, 31-32=-435/727, 29-31=-435/727, 28-29=0/3458, 27-28=0/3815, 25-27=0/2773, 24-25=0/326

**WEBS**  
9-34=-794/0, 11-32=0/616, 12-31=-633/0, 2-39=-1054/32, 2-37=-118/605, 4-37=-162/0, 5-37=-188/263, 5-36=-429/0, 6-36=-167/0, 7-36=0/855, 7-35=-1227/0, 8-35=-205/0, 9-35=0/1860, 11-34=-3441/0, 12-29=0/2604, 14-29=-560/0, 15-29=-664/0, 15-28=0/480, 16-28=-190/0, 17-28=-67/7, 17-27=-367/0, 18-27=-169/0, 19-27=0/813, 19-25=-1190/0, 21-25=-159/0, 22-25=0/1580, 22-24=-1010/0  
**NOTES**  
1) Unbalanced floor live loads have been considered for this design.  
2) All plates are MT20 plates unless otherwise indicated.  
3) All plates are 3x6 MT20 unless otherwise indicated.  
4) Recommend 2x6 strongbacks, on edge, spaced at 10-00-00 oc and fastened to each truss with 3-10d (0.131" X 3") nails. Strongbacks to be attached to walls at their outer ends or restrained by other means.  
5) CAUTION, Do not erect truss backwards.  
**LOAD CASE(S)** Standard



January 13, 2025

**WARNING - Verify design parameters and READ NOTES ON THIS AND INCLUDED MITEK REFERENCE PAGE MII-7473 rev. 1/2/2023 BEFORE USE.**  
Design valid for use only with MiTek® connectors. This design is based only upon parameters shown, and is for an individual building component, not a truss system. Before use, the building designer must verify the applicability of design parameters and properly incorporate this design into the overall building design. Bracing indicated is to prevent buckling of individual truss web and/or chord members only. Additional temporary and permanent bracing is always required for stability and to prevent collapse with possible personal injury and property damage. For general guidance regarding the fabrication, storage, delivery, erection and bracing of trusses and truss systems, see **ANSI/TP1 Quality Criteria and DSB-22** available from Truss Plate Institute (www.tpinst.org) and **BCSI Building Component Safety Information** available from the Structural Building Component Association (www.sbccomponents.com)

**ENGINEERING BY**  
**TRENCO**  
A MiTek Affiliate  
818 Soundside Road  
Edenton, NC 27932

Job 25010029-A	Truss F06	Truss Type Floor	Qty 1	Ply 1	132 Hidden Lakes North-2nd Floor-Plan 10 GRH I70703745 Job Reference (optional)
-------------------	--------------	---------------------	----------	----------	---

Carter Components (Sanford, NC), Sanford, NC - 27332,

Run: 8.73 S Dec 5 2024 Print: 8.730 S Dec 5 2024 MiTek Industries, Inc. Sun Jan 12 16:05:44  
ID:FisgYYHCW6NFUmRtJFCI2WzwhyI-RFC?PsB70Hq3NSgPqnL8w3uITXbGKWrcDoi7J4zJC?f

Page: 1

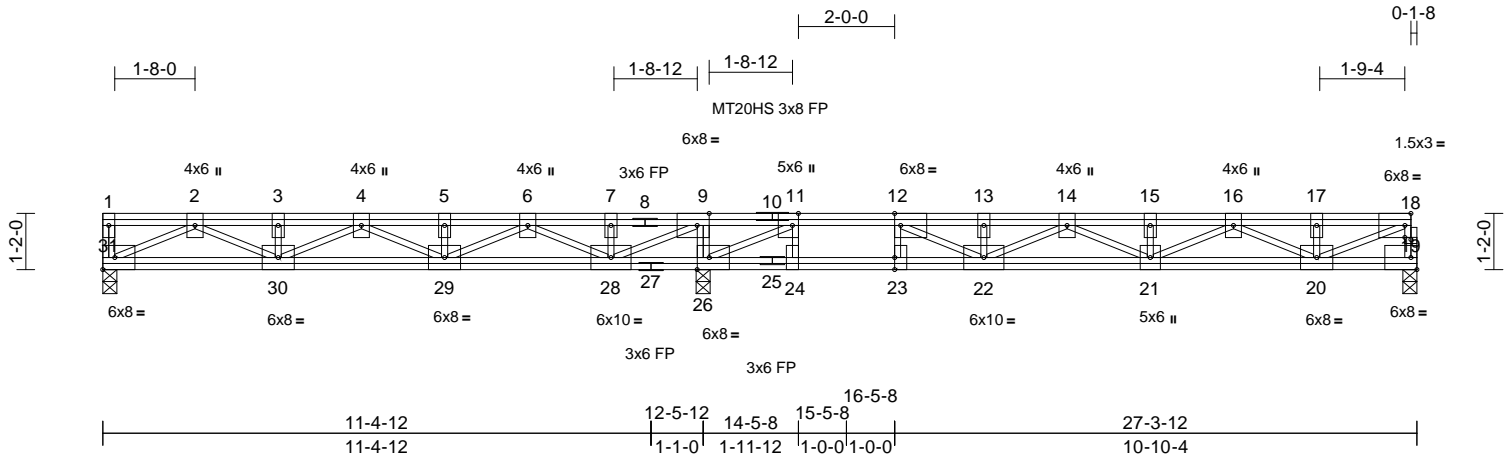

Scale = 1:47.9

Plate Offsets (X, Y): [9:0-3-0,Edge], [11:0-3-0,Edge], [12:0-1-8,Edge], [18:0-1-8,Edge], [18:0-1-8,0-0-8], [23:0-3-0,Edge], [26:0-3-0,Edge]

Loading	(psf)	Spacing	2-0-0	CSI	DEFL	in	(loc)	l/defl	L/d	PLATES	GRIP	
TCLL	40.0	Plate Grip DOL	1.00	TC	0.84	Vert(LL)	-0.17	22-23	>999	480	MT20	244/190
TCDL	10.0	Lumber DOL	1.00	BC	0.78	Vert(CT)	-0.24	22-23	>741	360	MT20HS	187/143
BCLL	0.0	Rep Stress Incr	YES	WB	0.84	Horz(CT)	0.02	19	n/a	n/a		
BCDL	5.0	Code	IRC2021/TPI2014	Matrix-MSH								Weight: 214 lb FT = 20%F, 11%E

**LUMBER**  
TOP CHORD 2x4 SP No.2(flat)  
BOT CHORD 2x4 SP No.2(flat)  
WEBS 2x4 SP No.3(flat)  
OTHERS 2x4 SP No.3(flat)

**BRACING**  
TOP CHORD Structural wood sheathing directly applied or 6-0-0 oc purlins, except end verticals.  
BOT CHORD Rigid ceiling directly applied or 6-0-0 oc bracing.

**REACTIONS** (size) 19=0-3-8, 26=0-3-8, 31=0-3-8  
Max Grav 19=734 (LC 4), 26=1739 (LC 1), 31=595 (LC 3)

**FORCES** (lb) - Maximum Compression/Maximum Tension  
TOP CHORD 1-31=-78/0, 18-19=-721/0, 1-2=0/0, 2-3=-1543/0, 3-4=-1543/0, 4-5=-1608/49, 5-6=-1608/49, 6-7=-248/658, 7-9=-248/658, 9-11=0/1795, 11-12=-1077/354, 12-13=-2487/0, 13-14=-2487/0, 14-15=-2562/0, 15-16=-2562/0, 16-17=-1350/0, 17-18=-1351/0  
BOT CHORD 30-31=0/974, 29-30=0/1744, 28-29=-320/1096, 26-28=-1795/0, 24-26=-354/1077, 23-24=-354/1077, 22-23=-354/1077, 21-22=0/2640, 20-21=0/2114, 19-20=0/0  
WEBS 9-26=-792/0, 11-24=0/481, 12-23=-487/0, 2-31=-1094/0, 2-30=0/644, 3-30=-161/0, 4-30=-228/90, 4-29=-262/0, 5-29=-166/0, 6-29=0/687, 6-28=-1063/0, 7-28=-196/0, 9-28=0/1650, 11-26=-2620/0, 12-22=0/1759, 13-22=-434/0, 14-22=-256/0, 14-21=-88/96, 15-21=-181/0, 16-21=0/507, 16-20=-865/0, 17-20=-186/0, 18-20=0/1484

**NOTES**  
1) Unbalanced floor live loads have been considered for this design.

- All plates are MT20 plates unless otherwise indicated.
- All plates are 3x6 MT20 unless otherwise indicated.
- Recommend 2x6 strongbacks, on edge, spaced at 10-00-00 oc and fastened to each truss with 3-10d (0.131" X 3") nails. Strongbacks to be attached to walls at their outer ends or restrained by other means.
- CAUTION, Do not erect truss backwards.

**LOAD CASE(S)** Standard

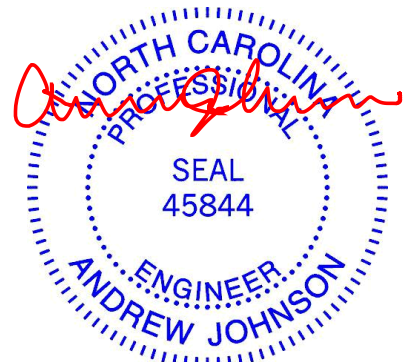

**WARNING - Verify design parameters and READ NOTES ON THIS AND INCLUDED MITEK REFERENCE PAGE MII-7473 rev. 1/2/2023 BEFORE USE.**

Design valid for use only with MiTek® connectors. This design is based only upon parameters shown, and is for an individual building component, not a truss system. Before use, the building designer must verify the applicability of design parameters and properly incorporate this design into the overall building design. Bracing indicated is to prevent buckling of individual truss web and/or chord members only. Additional temporary and permanent bracing is always required for stability and to prevent collapse with possible personal injury and property damage. For general guidance regarding the fabrication, storage, delivery, erection and bracing of trusses and truss systems, see **ANSI/TPI Quality Criteria and DSB-22** available from Truss Plate Institute (www.tpinst.org) and **BCSI Building Component Safety Information** available from the Structural Building Component Association (www.sbcacomponents.com)



818 Soundside Road  
Edenton, NC 27932

Job 25010029-A	Truss F05	Truss Type Floor	Qty 2	Ply 1	132 Hidden Lakes North-2nd Floor-Plan 10 GRH I70703746 Job Reference (optional)
-------------------	--------------	---------------------	----------	----------	---

Carter Components (Sanford, NC), Sanford, NC - 27332,

Run: 8.73 S Dec 5 2024 Print: 8.730 S Dec 5 2024 MiTek Industries, Inc. Sun Jan 12 16:05:44

Page: 1

ID:NPZJaYqMTRb2wwXZ4GXrWWzwhyu-RfC?PsB70Hq3NSgPqnL8w3uTXbGKWrCDoi7J4zJC?f

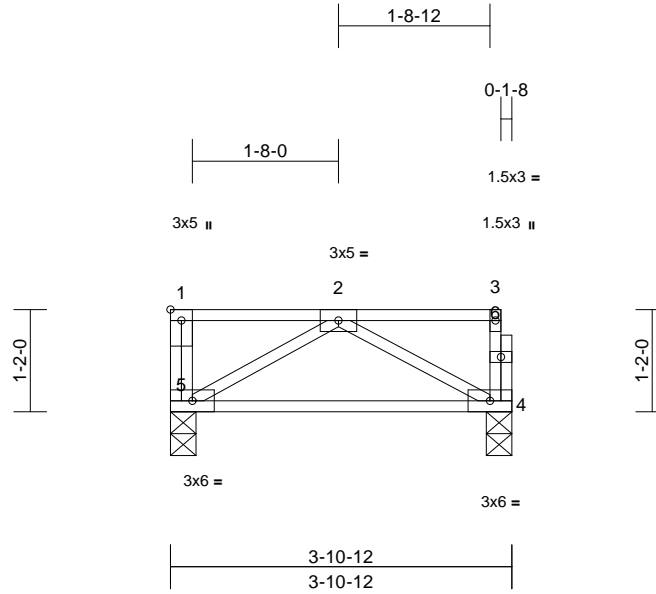

Scale = 1:26.3

Plate Offsets (X, Y): [1:Edge,0-1-8]

Loading	(psf)	Spacing	2-0-0	CSI	TC	0.55	DEFL	in	(loc)	l/defl	L/d	PLATES	GRIP
TCLL	40.0	Plate Grip DOL	1.00	TC	0.55	Vert(LL)	n/a	-	n/a	999	999	MT20	244/190
TCDL	10.0	Lumber DOL	1.00	BC	0.27	Vert(CT)	-0.03	4-5	>999	360	360		
BCLL	0.0	Rep Stress Incr	NO	WB	0.14	Horz(CT)	0.00	4	n/a	n/a	n/a		
BCDL	5.0	Code	IRC2021/TPI2014	Matrix-MP								Weight: 22 lb	FT = 20%F, 11%E

#### LUMBER

TOP CHORD 2x4 SP No.2(flat)  
 BOT CHORD 2x4 SP No.2(flat)  
 WEBS 2x4 SP No.3(flat)  
 OTHERS 2x4 SP No.3(flat)

#### BRACING

TOP CHORD Structural wood sheathing directly applied or 3-10-12 oc purlins, except end verticals.  
 BOT CHORD Rigid ceiling directly applied or 10-0-0 oc bracing.

**REACTIONS** (size) 4=0-3-8, 5=0-3-8  
 Max Grav 4=458 (LC 1), 5=474 (LC 1)

**FORCES** (lb) - Maximum Compression/Maximum Tension

TOP CHORD 1-5=-171/0, 3-4=-171/0, 1-2=0/0, 2-3=-10/0  
 BOT CHORD 4-5=0/490  
 WEBS 2-5=-567/0, 2-4=-550/0

#### NOTES

- 1) Recommend 2x6 strongbacks, on edge, spaced at 10-00-00 oc and fastened to each truss with 3-10d (0.131" X 3") nails. Strongbacks to be attached to walls at their outer ends or restrained by other means.
- 2) CAUTION, Do not erect truss backwards.
- 3) In the LOAD CASE(S) section, loads applied to the face of the truss are noted as front (F) or back (B).

#### LOAD CASE(S) Standard

- 1) Dead + Floor Live (balanced): Lumber Increase=1.00, Plate Increase=1.00  
 Uniform Loads (lb/ft)  
 Vert: 4-5=-10, 1-3=-250 (F=-150)

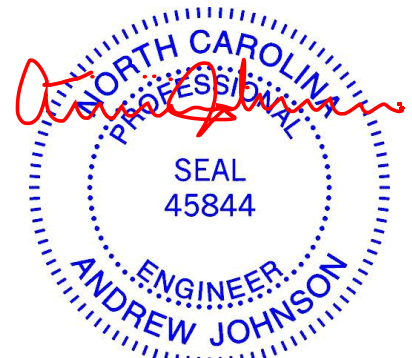

January 13, 2025

**WARNING - Verify design parameters and READ NOTES ON THIS AND INCLUDED MITEK REFERENCE PAGE MII-7473 rev. 1/2/2023 BEFORE USE.**

Design valid for use only with MiTek® connectors. This design is based only upon parameters shown, and is for an individual building component, not a truss system. Before use, the building designer must verify the applicability of design parameters and properly incorporate this design into the overall building design. Bracing indicated is to prevent buckling of individual truss web and/or chord members only. Additional temporary and permanent bracing is always required for stability and to prevent collapse with possible personal injury and property damage. For general guidance regarding the fabrication, storage, delivery, erection and bracing of trusses and truss systems, see **ANSI/TP1 Quality Criteria and DSB-22** available from Truss Plate Institute ([www.tpinst.org](http://www.tpinst.org)) and **BCSI Building Component Safety Information** available from the Structural Building Component Association ([www.sbcacomponents.com](http://www.sbcacomponents.com))

ENGINEERING BY  
**TRENCO**  
 A MiTek Affiliate

818 Soundside Road  
 Edenton, NC 27932

Job 25010029-A	Truss F04	Truss Type Floor	Qty 1	Ply 1	132 Hidden Lakes North-2nd Floor-Plan 10 GRH I70703747 Job Reference (optional)
-------------------	--------------	---------------------	----------	----------	---

Carter Components (Sanford, NC), Sanford, NC - 27332,

Run: 8.73 S Dec 5 2024 Print: 8.730 S Dec 5 2024 MiTek Industries, Inc. Sun Jan 12 16:05:44  
ID:JW9eQqey?qiAdcuhidJPLzwhz7-RfC?PsB70Hq3NSgPqnL8w3uITXbGKWRcDoi7J4zJC?f

Page: 1

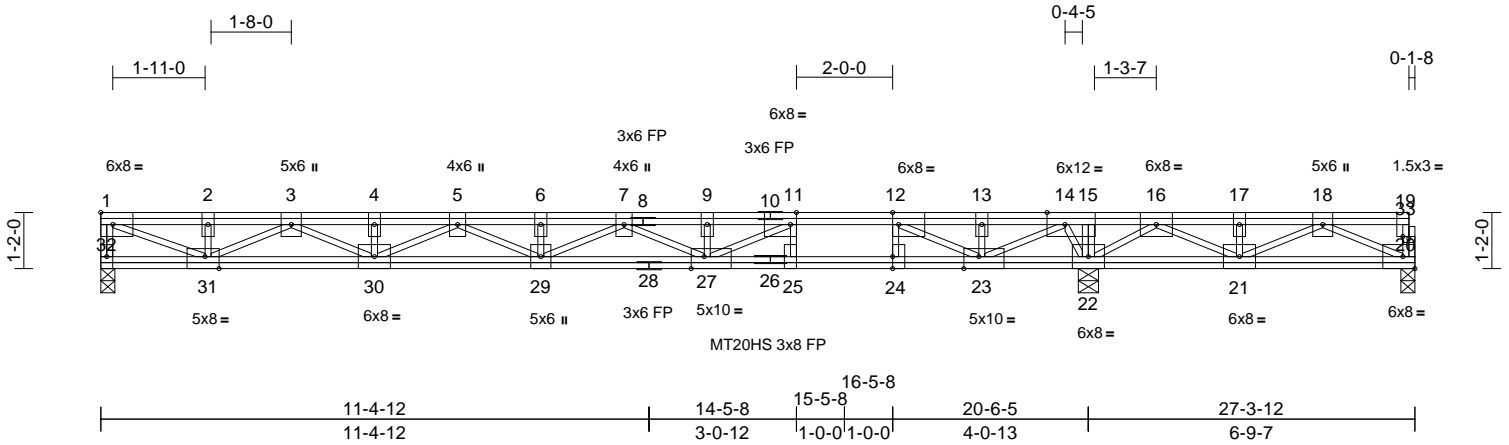

Scale = 1:47.9

Plate Offsets (X, Y): [11:0-1-8,Edge], [12:0-1-8,Edge], [15:0-4-8,Edge], [23:0-3-12,Edge], [24:0-3-0,Edge], [27:0-3-4,Edge], [31:0-3-8,Edge], [33:0-1-8,0-0-8]

Loading	(psf)	Spacing	2-0-0	CSI	DEFL	in	(loc)	l/defl	L/d	PLATES	GRIP	
TCLL	40.0	Plate Grip DOL	1.00	TC	0.94	Vert(LL)	-0.33	27-29	>739	480	MT20	244/190
TCDL	10.0	Lumber DOL	1.00	BC	0.81	Vert(CT)	-0.45	27-29	>538	360	MT20HS	187/143
BCLL	0.0	Rep Stress Incr	YES	WB	0.99	Horz(CT)	0.03	22	n/a	n/a		
BCDL	5.0	Code	IRC2021/TPI2014	Matrix-MSH								
											Weight: 214 lb	FT = 20%F, 11%E

**LUMBER**

TOP CHORD 2x4 SP No.2(flat)

BOT CHORD 2x4 SP No.2(flat) \*Except\* 28-20,26-20:2x4 SP No.1(flat)

WEBS 2x4 SP No.3(flat) \*Except\* 27-11,23-14:2x4 SP No.2(flat)

OTHERS 2x4 SP No.3(flat)

**BRACING**

TOP CHORD Structural wood sheathing directly applied or 6-0-0 oc purlins, except end verticals.

BOT CHORD Rigid ceiling directly applied or 10-0-0 oc bracing, Except: 6-0-0 oc bracing: 22-23,21-22,20-21.

**REACTIONS** (size) 20=0-3-8, 22=0-5-1, 32=0-3-8  
Max Uplift 20=428 (LC 3)  
Max Grav 20=200 (LC 4), 22=2201 (LC 1), 32=952 (LC 3)

**FORCES** (lb) - Maximum Compression/Maximum Tension

TOP CHORD 1-32=-932/0, 19-20=-72/0, 1-2=-1913/0, 2-3=-1913/0, 3-4=-3893/0, 4-5=-3893/0, 5-6=-4432/0, 6-7=-4432/0, 7-9=-3729/0, 9-11=-3729/0, 11-12=-1752/0, 12-13=0/1328, 13-14=0/1328, 14-15=0/3690, 15-16=0/3690, 16-17=-59/1775, 17-18=-59/1775, 18-19=0/0

BOT CHORD 31-32=0/0, 30-31=0/3064, 29-30=0/4327, 27-29=0/4185, 25-27=0/1752, 24-25=0/1752, 23-24=0/1752, 22-23=-3081/0, 21-22=-2802/0, 20-21=-854/211

WEBS 11-25=-642/0, 12-24=0/686, 15-22=-182/0, 11-27=0/2291, 9-27=-473/0, 7-27=-550/0, 7-29=0/316, 6-29=-181/0, 5-29=0/119, 5-30=-491/0, 4-30=-167/0, 3-30=0/938, 3-31=-1303/0, 2-31=-205/0, 1-31=0/2086, 12-23=-3217/0, 13-23=-58/301, 14-23=0/2139, 14-22=-1341/0, 18-20=-238/967, 18-21=-1043/0, 17-21=-176/0, 16-21=0/1357, 16-22=-1357/0

- NOTES**
- 1) Unbalanced floor live loads have been considered for this design.
  - 2) All plates are MT20 plates unless otherwise indicated.
  - 3) All plates are 3x6 MT20 unless otherwise indicated.
  - 4) Provide mechanical connection (by others) of truss to bearing plate capable of withstanding 428 lb uplift at joint 20.
  - 5) Recommend 2x6 strongbacks, on edge, spaced at 10-00-00 oc and fastened to each truss with 3-10d (0.131" X 3") nails. Strongbacks to be attached to walls at their outer ends or restrained by other means.
  - 6) CAUTION, Do not erect truss backwards.
- LOAD CASE(S)** Standard



**WARNING - Verify design parameters and READ NOTES ON THIS AND INCLUDED MITEK REFERENCE PAGE MII-7473 rev. 1/2/2023 BEFORE USE.**  
Design valid for use only with MiTek® connectors. This design is based only upon parameters shown, and is for an individual building component, not a truss system. Before use, the building designer must verify the applicability of design parameters and properly incorporate this design into the overall building design. Bracing indicated is to prevent buckling of individual truss web and/or chord members only. Additional temporary and permanent bracing is always required for stability and to prevent collapse with possible personal injury and property damage. For general guidance regarding the fabrication, storage, delivery, erection and bracing of trusses and truss systems, see **ANSI/TPI1 Quality Criteria and DSB-22** available from Truss Plate Institute (www.tpinst.org) and **BCSI Building Component Safety Information** available from the Structural Building Component Association (www.sbccomponents.com)





Job 25010029-A	Truss F03	Truss Type Floor	Qty 2	Ply 1	132 Hidden Lakes North-2nd Floor-Plan 10 GRH I70703748 Job Reference (optional)
-------------------	--------------	---------------------	----------	----------	---

Carter Components (Sanford, NC), Sanford, NC - 27332,

Run: 8.73 S Dec 5 2024 Print: 8.730 S Dec 5 2024 MiTek Industries, Inc. Sun Jan 12 16:05:43  
ID:BkLI79H83cwQ1?bwyKDHB0zwhzb-RfC?PsB70Hq3NSgPqnL8w3ulTXbGKwRcDoi7J4zJC?f

Page: 1

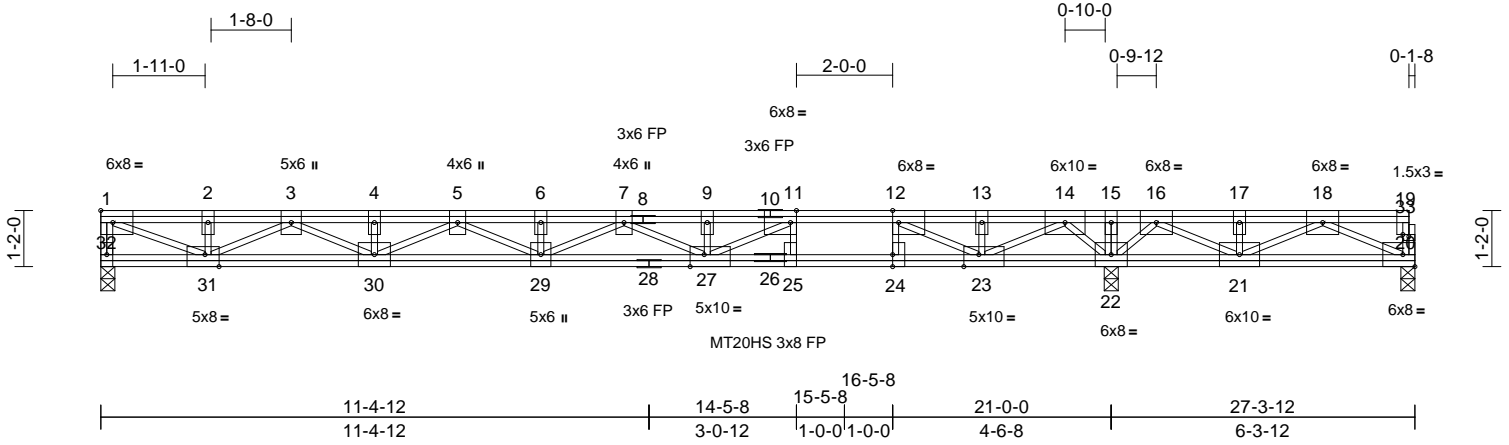

Scale = 1:47.9

Plate Offsets (X, Y): [11:0-1-8,Edge], [12:0-1-8,Edge], [23:0-3-12,Edge], [24:0-3-0,Edge], [27:0-3-8,Edge], [31:0-3-8,Edge], [33:0-1-8,0-0-8]

Loading	(psf)	Spacing	2-0-0	CSI	DEFL	in	(loc)	l/defl	L/d	PLATES	GRIP	
TCLL	40.0	Plate Grip DOL	1.00	TC	0.88	Vert(LL)	-0.35	27-29	>725	480	MT20	244/190
TCDL	10.0	Lumber DOL	1.00	BC	0.83	Vert(CT)	-0.47	27-29	>528	360	MT20HS	187/143
BCLL	0.0	Rep Stress Incr	YES	WB	0.76	Horz(CT)	0.04	22	n/a	n/a		
BCDL	5.0	Code	IRC2021/TPI2014	Matrix-MSH								
											Weight: 214 lb	FT = 20%F, 11%E

**LUMBER**

TOP CHORD 2x4 SP No.2(flat)

BOT CHORD 2x4 SP No.2(flat) \*Except\* 28-20,26-20:2x4 SP No.1(flat)

WEBS 2x4 SP No.3(flat) \*Except\* 27-11,31-1,23-14:2x4 SP No.2(flat)

OTHERS 2x4 SP No.3(flat)

**BRACING**

TOP CHORD Structural wood sheathing directly applied or 6-0-0 oc purlins, except end verticals.

BOT CHORD Rigid ceiling directly applied or 10-0-0 oc bracing, Except: 6-0-0 oc bracing: 22-23,21-22,20-21.

**REACTIONS** (size) 20=0-3-8, 22=0-3-8, 32=0-3-8  
Max Uplift 20=522 (LC 3)  
Max Grav 20=152 (LC 4), 22=2296 (LC 1), 32=968 (LC 3)

**FORCES** (lb) - Maximum Compression/Maximum Tension

TOP CHORD 1-32=-949/0, 19-20=-71/0, 1-2=-1953/0, 2-3=-1953/0, 3-4=-3990/0, 4-5=-3990/0, 5-6=-4590/0, 6-7=-4590/0, 7-9=-3944/0, 9-11=-3944/0, 11-12=-2019/0, 12-13=0/1038, 13-14=0/1038, 14-15=0/3997, 15-16=0/3997, 16-17=0/2128, 17-18=0/2128, 18-19=0/0

BOT CHORD 31-32=0/0, 30-31=0/3132, 29-30=0/4454, 27-29=0/4374, 25-27=0/2019, 24-25=0/2019, 23-24=0/2019, 22-23=-2754/0, 21-22=-3305/0, 20-21=-1029/121

WEBS 11-25=-630/0, 12-24=0/669, 15-22=-163/0, 11-27=0/2239, 9-27=-468/0, 7-27=-523/0, 7-29=-3/287, 6-29=-181/0, 5-29=0/154, 5-30=-525/0, 4-30=-167/0, 3-30=0/972, 3-31=-1334/0, 2-31=-207/0, 1-31=0/2131, 12-23=-3142/0, 13-23=-69/286, 14-23=0/2163, 14-22=-1730/0, 18-20=-137/1165, 18-21=-1244/0, 17-21=-166/0, 16-21=0/1562, 16-22=-1183/0

- NOTES**
- 1) Unbalanced floor live loads have been considered for this design.
  - 2) All plates are MT20 plates unless otherwise indicated.
  - 3) All plates are 3x6 MT20 unless otherwise indicated.
  - 4) Provide mechanical connection (by others) of truss to bearing plate capable of withstanding 522 lb uplift at joint 20.
  - 5) Recommend 2x6 strongbacks, on edge, spaced at 10-00-00 oc and fastened to each truss with 3-10d (0.131" X 3") nails. Strongbacks to be attached to walls at their outer ends or restrained by other means.
  - 6) CAUTION, Do not erect truss backwards.
- LOAD CASE(S)** Standard

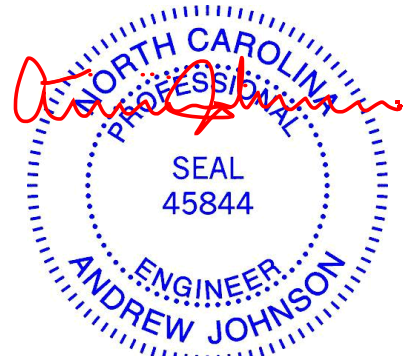

January 13, 2025

**WARNING - Verify design parameters and READ NOTES ON THIS AND INCLUDED MITEK REFERENCE PAGE MII-7473 rev. 1/2/2023 BEFORE USE.**

Design valid for use only with MiTek® connectors. This design is based only upon parameters shown, and is for an individual building component, not a truss system. Before use, the building designer must verify the applicability of design parameters and properly incorporate this design into the overall building design. Bracing indicated is to prevent buckling of individual truss web and/or chord members only. Additional temporary and permanent bracing is always required for stability and to prevent collapse with possible personal injury and property damage. For general guidance regarding the fabrication, storage, delivery, erection and bracing of trusses and truss systems, see **ANSI/TPI1 Quality Criteria and DSB-22** available from Truss Plate Institute (www.tpinst.org) and **BCSI Building Component Safety Information** available from the Structural Building Component Association (www.sbcacomponents.com)



818 Soundside Road  
Edenton, NC 27932



Job 25010029-A	Truss F01	Truss Type Floor	Qty 1	Ply 1	132 Hidden Lakes North-2nd Floor-Plan 10 GRH I70703750 Job Reference (optional)
-------------------	--------------	---------------------	----------	----------	---

Carter Components (Sanford, NC), Sanford, NC - 27332,

Run: 8.73 S Dec 5 2024 Print: 8.730 S Dec 5 2024 MiTek Industries, Inc. Sun Jan 12 16:05:42  
ID:LzpTTEzOVRJ4PL9deHypFzwi?H-RfC?PsB70Hq3NSgPqnL8w3uITXbGKWrCDoi7J4zJC?f

Page: 1

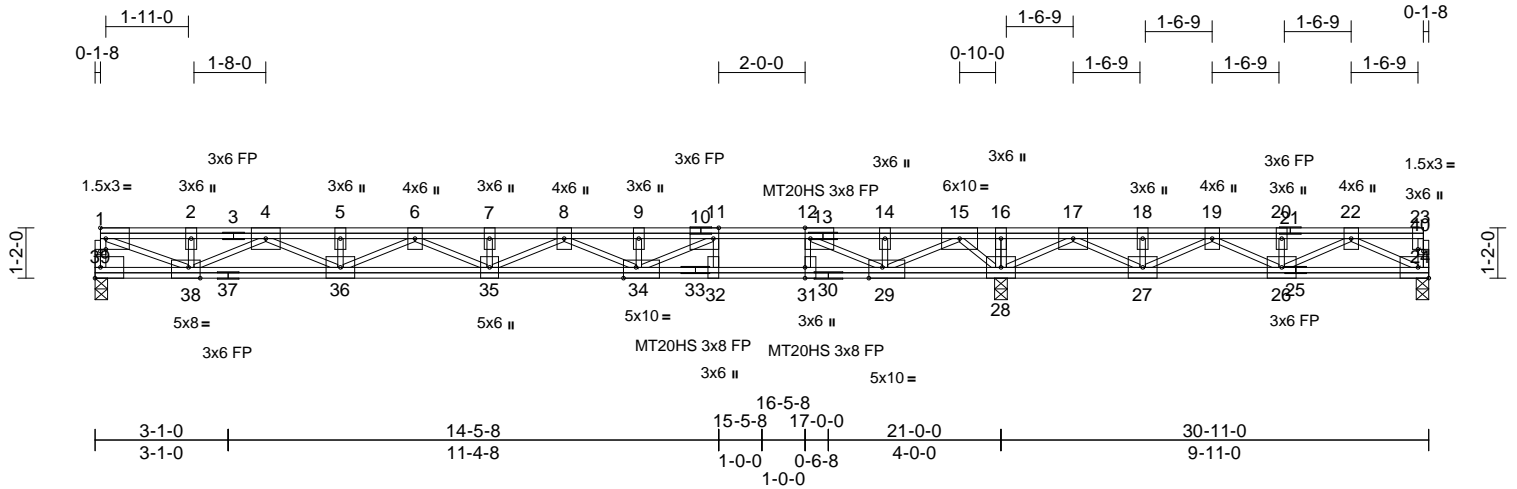

Scale = 1:53.4

Plate Offsets (X, Y): [1:0-1-8,0-0-8], [11:0-1-8,Edge], [12:0-1-8,Edge], [29:0-3-12,Edge], [31:0-3-0,Edge], [34:0-3-8,Edge], [38:0-3-4,Edge], [40:0-1-8,0-0-8]

Loading	(psf)	Spacing	2-0-0	CSI	DEFL	in	(loc)	l/defl	L/d	PLATES	GRIP	
TCLL	40.0	Plate Grip DOL	1.00	TC	0.82	Vert(LL)	-0.35	34-35	>711	480	MT20	244/190
TCDL	10.0	Lumber DOL	1.00	BC	0.85	Vert(CT)	-0.48	34-35	>520	360	MT20HS	187/143
BCLL	0.0	Rep Stress Incr	YES	WB	0.75	Horz(CT)	0.04	28	n/a	n/a		
BCDL	5.0	Code	IRC2021/TPI2014	Matrix-MSH								
											Weight: 242 lb	FT = 20%F, 11%E

LUMBER	WEBS
TOP CHORD 2x4 SP No.2(flat)	11-32=-627/0, 12-31=0/663, 16-28=-219/0,
BOT CHORD 2x4 SP No.2(flat) *Except* 37-30,33-25:2x4 SP No.1(flat)	11-34=0/2230, 9-34=-466/0, 8-34=-518/0,
WEBS 2x4 SP No.3(flat) *Except*	8-35=0/274, 7-35=-176/0, 6-35=0/178,
34-11,38-1,29-15:2x4 SP No.2(flat)	6-36=-561/0, 5-36=-163/0, 4-36=0/998,
OTHERS 2x4 SP No.3(flat)	4-38=-1365/0, 2-38=-188/0, 1-38=0/2159,
	12-29=-3120/0, 14-29=-69/285,
	15-29=0/2158, 15-28=-1724/0,
	17-28=-1550/0, 17-27=0/1279, 18-27=-170/0,
	19-27=-930/0, 19-26=0/683, 20-26=-151/0,
	22-26=-542/279, 22-24=-644/468

- NOTES**
- 1) Unbalanced floor live loads have been considered for this design.
  - 2) All plates are MT20 plates unless otherwise indicated.
  - 3) All plates are 3x6 MT20 unless otherwise indicated.
  - 4) n/a
  - 5) Recommend 2x6 strongbacks, on edge, spaced at 10-00-00 oc and fastened to each truss with 3-10d (0.131" X 3") nails. Strongbacks to be attached to walls at their outer ends or restrained by other means.
  - 6) CAUTION, Do not erect truss backwards.

REACTIONS	(size)	24=0-3-8, 28=0-3-8, 39=0-3-8
Max Uplift	24=-210 (LC 3)	
Max Grav	24=402 (LC 4), 28=2246 (LC 1), 39=982 (LC 3)	
FORCES	(lb) - Maximum Compression/Maximum Tension	
TOP CHORD	1-39=-964/0, 23-24=-68/0, 1-2=-1987/0, 2-4=-1986/0, 4-5=-4074/0, 5-6=-4074/0, 6-7=-4727/0, 7-8=-4727/0, 8-9=-4135/0, 9-11=-4135/0, 11-12=-2256/0, 12-14=0/974, 14-15=0/974, 15-16=0/3866, 16-17=0/3866, 17-18=-347/2119, 18-19=-347/2119, 19-20=-802/878, 20-22=-802/878, 22-23=0/0	
BOT CHORD	38-39=0/0, 36-38=0/3192, 35-36=0/4570, 34-35=0/4542, 32-34=0/2256, 31-32=0/2256, 29-31=0/2256, 28-29=-2644/0, 27-28=-2858/0, 26-27=-1471/721, 24-26=-407/560	

Standard

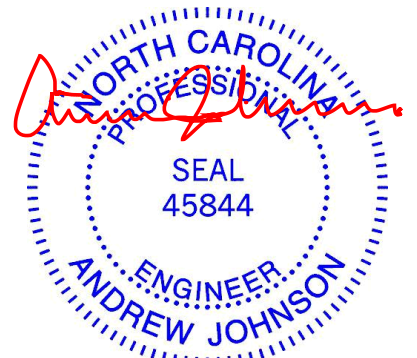

January 13, 2025

**WARNING - Verify design parameters and READ NOTES ON THIS AND INCLUDED MITEK REFERENCE PAGE MII-7473 rev. 1/2/2023 BEFORE USE.**

Design valid for use only with MiTek® connectors. This design is based only upon parameters shown, and is for an individual building component, not a truss system. Before use, the building designer must verify the applicability of design parameters and properly incorporate this design into the overall building design. Bracing indicated is to prevent buckling of individual truss web and/or chord members only. Additional temporary and permanent bracing is always required for stability and to prevent collapse with possible personal injury and property damage. For general guidance regarding the fabrication, storage, delivery, erection and bracing of trusses and truss systems, see **ANSI/TP1 Quality Criteria and DSB-22** available from Truss Plate Institute (www.tpinst.org) and **BCSI Building Component Safety Information** available from the Structural Building Component Association (www.sbcacomponents.com)



818 Soundside Road  
Edenton, NC 27932

# Symbols

## PLATE LOCATION AND ORIENTATION

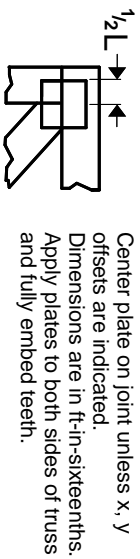

Center plate on joint unless x, y offsets are indicated. Dimensions are in ft-in-sixteenths. Apply plates to both sides of truss and fully embed teeth.

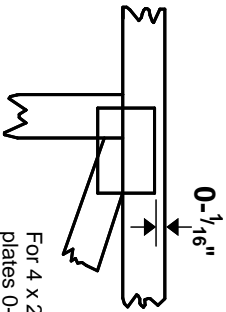

For 4 x 2 orientation, locate plates 0- 1/16\" from outside edge of truss.

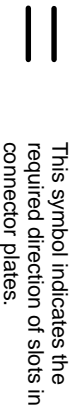

\* Plate location details available in MITek software or upon request.

## PLATE SIZE

**4 X 4**  
The first dimension is the plate width measured perpendicular to slots. Second dimension is the length parallel to slots.

## LATERAL BRACING LOCATION



Indicated by symbol shown and/or by text in the bracing section of the output. Use T or I bracing if indicated.

## BEARING

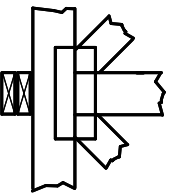

Indicates location where bearings (supports) occur. Icons vary but reaction section indicates joint number/letter where bearings occur. Min size shown is for crushing only.

## Industry Standards:

ANSI/TP1: National Design Specification for Metal Plate Connected Wood Truss Construction.  
DSB-22: Design Standard for Bracing.  
BCSI: Building Component Safety Information, Guide to Good Practice for Handling, Installing, Restraining & Bracing of Metal Plate Connected Wood Trusses.

# Numbering System

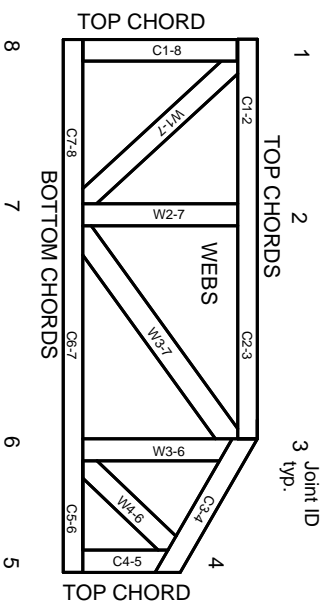

**JOINTS ARE GENERALLY NUMBERED/LETTERED CLOCKWISE AROUND THE TRUSS STARTING AT THE JOINT FARTHEST TO THE LEFT.**

**CHORDS AND WEBS ARE IDENTIFIED BY END JOINT NUMBERS/LETTERS.**

# Product Code Approvals

ICC-ES Reports:

ESR-1988, ESR-2362, ESR-2685, ESR-3282  
ESR-4722, ESL-1388

# Design General Notes

Trusses are designed for wind loads in the plane of the truss unless otherwise shown.

Lumber design values are in accordance with ANSI/TP1 section 6.3. These truss designs rely on Lumber values established by others.

© 2023 MITek® All Rights Reserved

**MITek**

ENGINEERING BY  
**TRENGO**  
A MITek Affiliate

MITek Engineering Reference Sheet: MIL-7473 rev. 1/2/2023

# General Safety Notes

## Failure to Follow Could Cause Property Damage or Personal Injury

1. Additional stability/bracing for truss system, e.g. diagonal or X-bracing, is always required. See BCSI.
2. Truss bracing must be designed by an engineer. For wide truss spacing, individual lateral braces themselves may require bracing, or alternative Tor I bracing should be considered.
3. Never exceed the design loading shown and never stack materials on inadequately braced trusses.
4. Provide copies of this truss design to the building designer, erection supervisor, property owner and all other interested parties.
5. Cut members to bear tightly against each other.
6. Place plates on each face of truss at each joint and embed fully. Knots and wane at joint locations are regulated by ANSI/TP1 1.
7. Design assumes trusses will be suitably protected from the environment in accord with ANSI/TP1 1.
8. Unless otherwise noted, moisture content of lumber shall not exceed 19% at time of fabrication.
9. Unless expressly noted, this design is not applicable for use with fire retardant, preservative treated, or green lumber.
10. Camber is a non-structural consideration and is the responsibility of truss fabricator. General practice is to camber for dead load deflection.
11. Plate type, size, orientation and location dimensions indicated are minimum plating requirements.
12. Lumber used shall be of the species and size, and in all respects, equal to or better than that specified.
13. Top chords must be sheathed or purlins provided at spacing indicated on design.
14. Bottom chords require lateral bracing at 10 ft. spacing, or less, if no ceiling is installed, unless otherwise noted.
15. Connections not shown are the responsibility of others.
16. Do not cut or alter truss member or plate without prior approval of an engineer.
17. Install and load vertically unless indicated otherwise.
18. Use of green or treated lumber may pose unacceptable environmental, health or performance risks. Consult with project engineer before use.
19. Review all portions of this design (front, back, words and pictures) before use. Reviewing pictures alone is not sufficient.
20. Design assumes manufacture in accordance with ANSI/TP1 Quality Criteria.
21. The design does not take into account any dynamic or other loads other than those expressly stated.