



**FRONT ELEVATION**

Scale: 1/4" = 1'0"

9'0" CEILING HEIGHT FIRST FLOOR  
(HEADER HEIGHT 7'6")  
8'0" CEILING HEIGHT SECOND FLOOR  
(FRAME HEADERS TO TOP PLATES ON 2ND FLOOR)

FRAME WINDOWS TO HEADER HEIGHT



**LEFT ELEVATION**

Scale: 1/8" = 1'0"



**REAR ELEVATION**

Scale: 1/8" = 1'0"



**RIGHT ELEVATION**

Scale: 1/8" = 1'0"

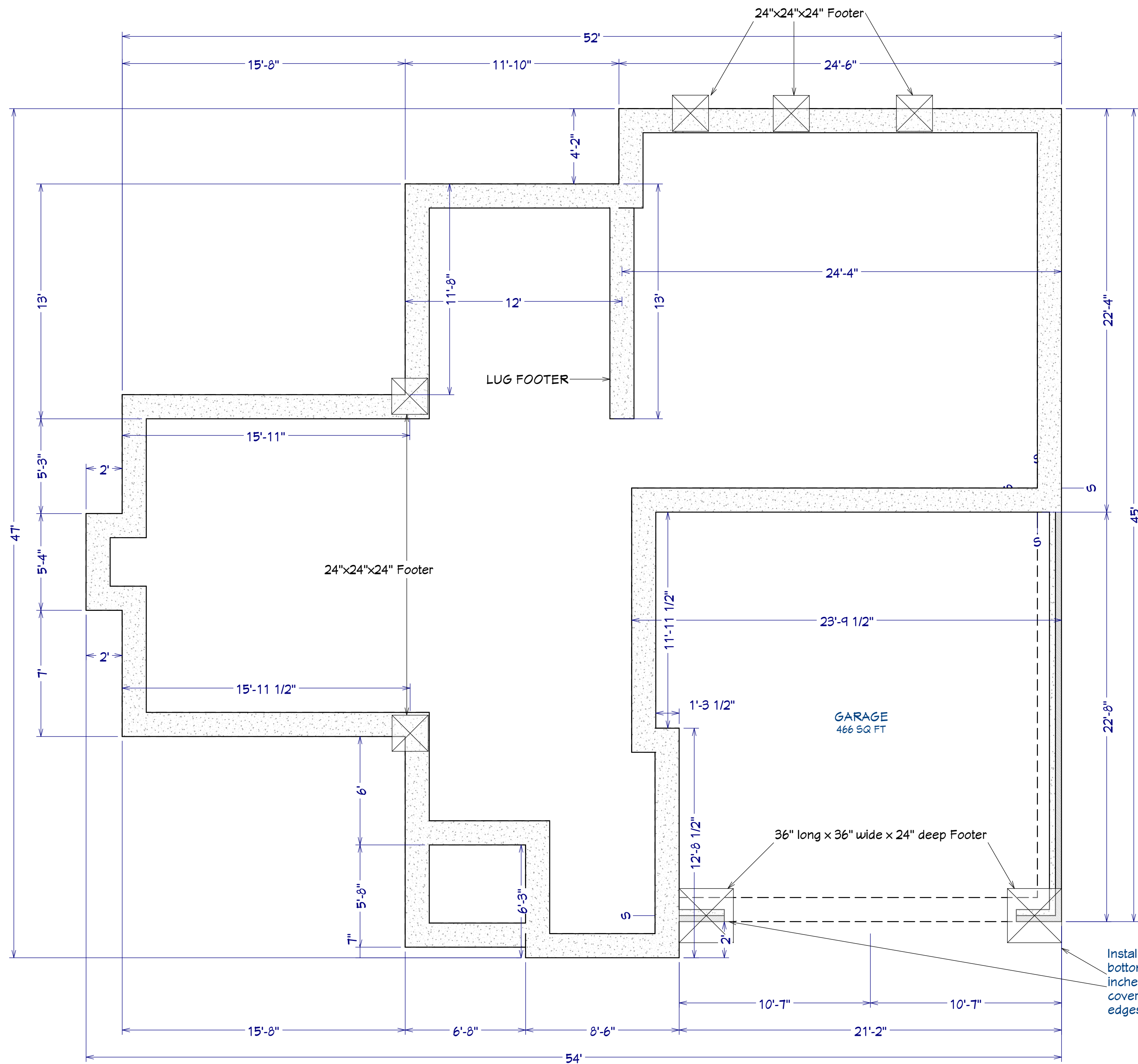

AREA SCHEDULE	
NAME	AREA
1st FLOOR	1,403 SF
2nd FLOOR	1,074 SF
<hr/>	
GARAGE	497 SF
FRONT PORCH	35 SF
COVERED PORCH	183 SF
<hr/>	
TOTAL HEATED	2,477 SF
<hr/>	
TOTAL UNDER ROOF	3,192 SF

Install bottom mat of #4 reinforcing steel (2- #4 bars ea way) in the bottom of the footing on rebar chairs providing a minimum of 3 inches of cover from the bottom of the footing. Ensure a minimum cover of 1 1/2" of cover between the sides of the footing and the edges of the rebar.

**FOUNDATION PLAN**  
Scale: 1/4" = 1'0"

SHEET TITLE:  
**FOUNDATION**

PROJECT ADDRESS:  
145 Mahogany Ct.  
Magnolia Hills Lot 26

DESIGNED BY:  
Precision Custom Homes  
Rae ford, NC  
Shaun@PrecisionCustomHomesNC.com

DATE:  
1/6/25

SCALE:  
1/4" = 1'

SHEET:  
**A-2**

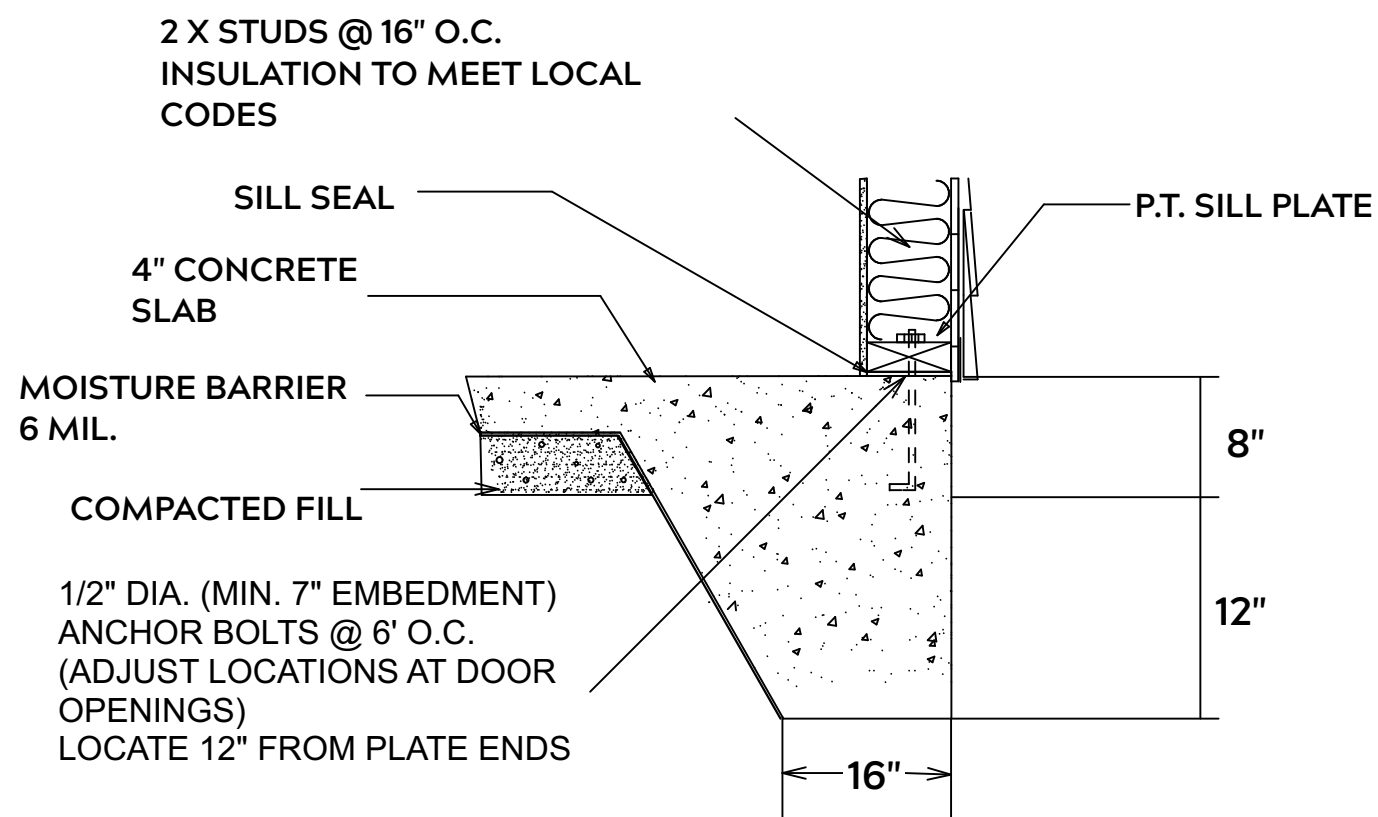

**MONOLITHIC SLAB**

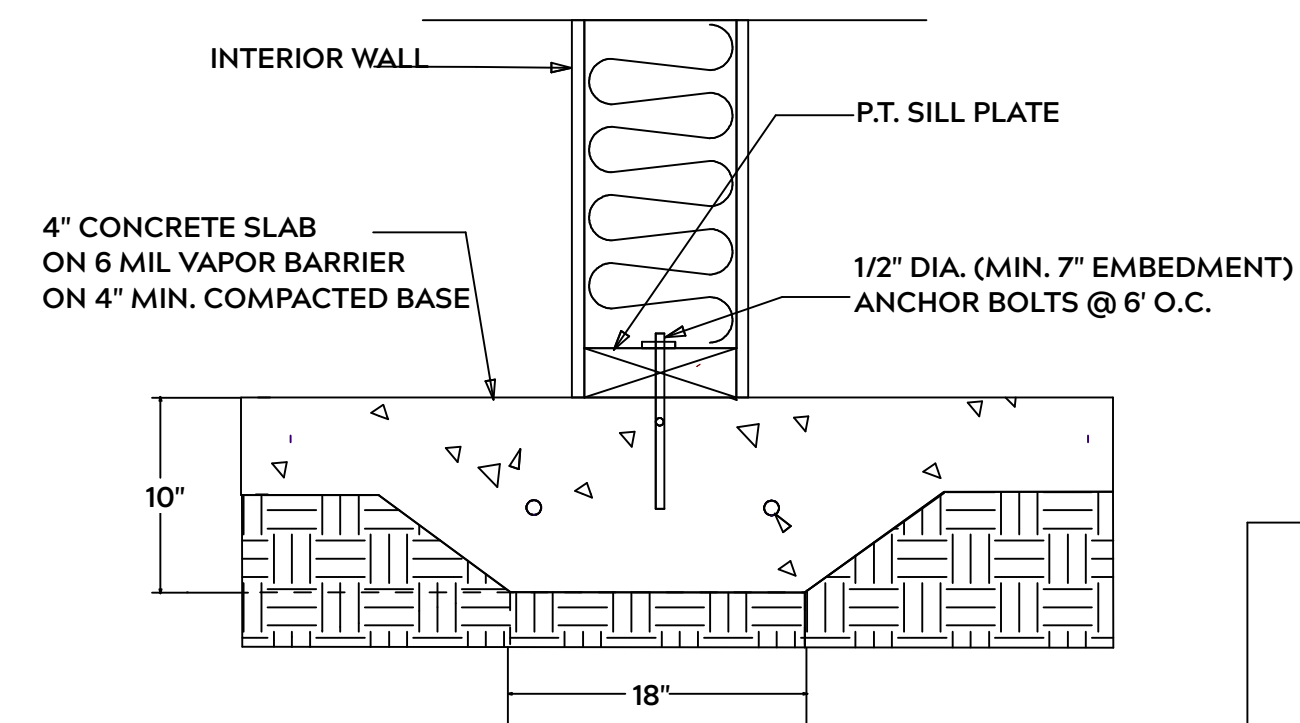

**LUG FOOTING**

**FOUNDATION NOTES:**

ALL FOOTINGS SHALL BEAR ON ORIGINAL UNDISTURBED SOIL  
THE 28 DAY COMPRESSIVE STRENGTH OF ALL FOOTINGS IS 3000 PSI

PROVIDE WATER PROOFING AND PERIMTER DRAINS AS REQUIRED

FOOTING WIDTHS ARE BASED ON A LOAD BEARING SOIL CAPACITY OF 2000 PSI

PROVIDE 6 MIL POLY VAPOR BARRIER TO COVER GROUND IN CRAWL SPACE AND GROUND UNDER POURED CONCRETE

ALL ANCHOR BOLTS TO BE 1/2" X 12" LONG. ANCHOR BOLTS SHALL BE SPACED AT A MAXIMUM OF 6' ON CENTER AND NO MORE THEN 1' FROM EACH CORNER

**GENERAL FRAMING NOTES:**

ALL LUMBER IN CONTACT WITH CONCRETE OR MASONRY SHALLE BE PRESSURE TREATED

FRAMING LUMBER SHALL BE SYP #2 GRADE AND / OR SPRUCE PINE FIR #1 AND / OR KILN DRIED

WHERE PRE-ENGINEERED JOISTS AND TRUSSES ARE USED, MANUFACTURER SHALL PROVIDE DRAWINGS / SCHEMATICS, WHICH SHALL BEAR OF A N.C. ENGINEER

STUDS AND JOISTS SHALL NOT BE CUT TO INSTALL PLUMBING OR WIRING WITHOUT ADDING METAL OR WOOD SIDE PANELS TO STRENGTHEN MEMBER TO ITS ORIGINAL CAPACITY

NAIL MULTIPLE MEMBERS WITH 2 ROWS OF 16d NAILS STAGGERED 32" O.C. AND USE 3 X 16d NAILS 2" IN AT EACH END.

NAIL FLOOR JOISTS TO SILL PLATE WITH WITH 8d TOE NAILS

ALL EXPOSED FRAMING ON PORCHES OR DECKS SHALL BE PRESSURE TREATED

PROVIDE WATERPROOFING AND DRAINS AS REQUIRED

ALL FRAMING TO BE 16" O.C. WALL FRAMING DIMENSIONS ARE BASED ON 2X4 OR 2X6 EXTERIOR WALLS AND 2X4 INTERIOR WALLS. DOULBE / TRIPLE JACK STUDS AS NECESSARY UNDER HEADERS AS REQUIRED

LVL'S TO BE SIZED BY OTHERS (TRUSS MANUFACTURER)

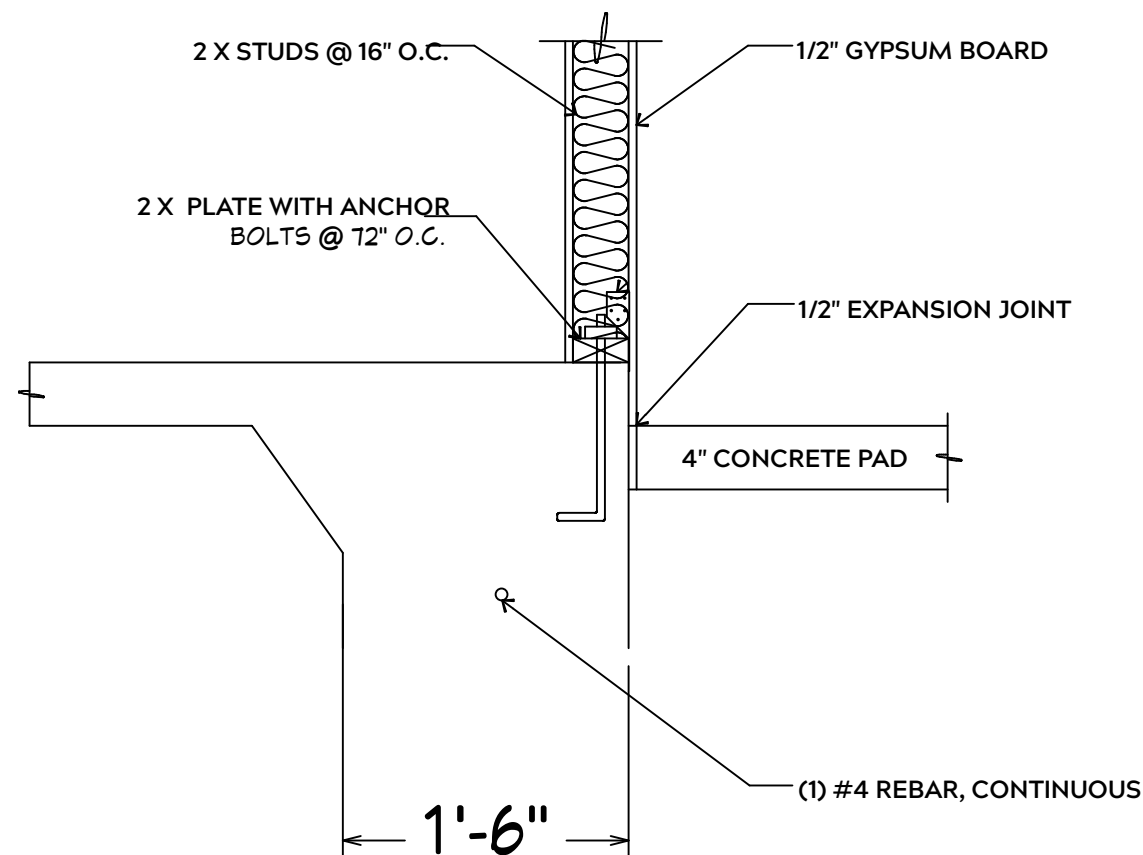

**INTERIOR WALL @ GARAGE STEP DOWN**

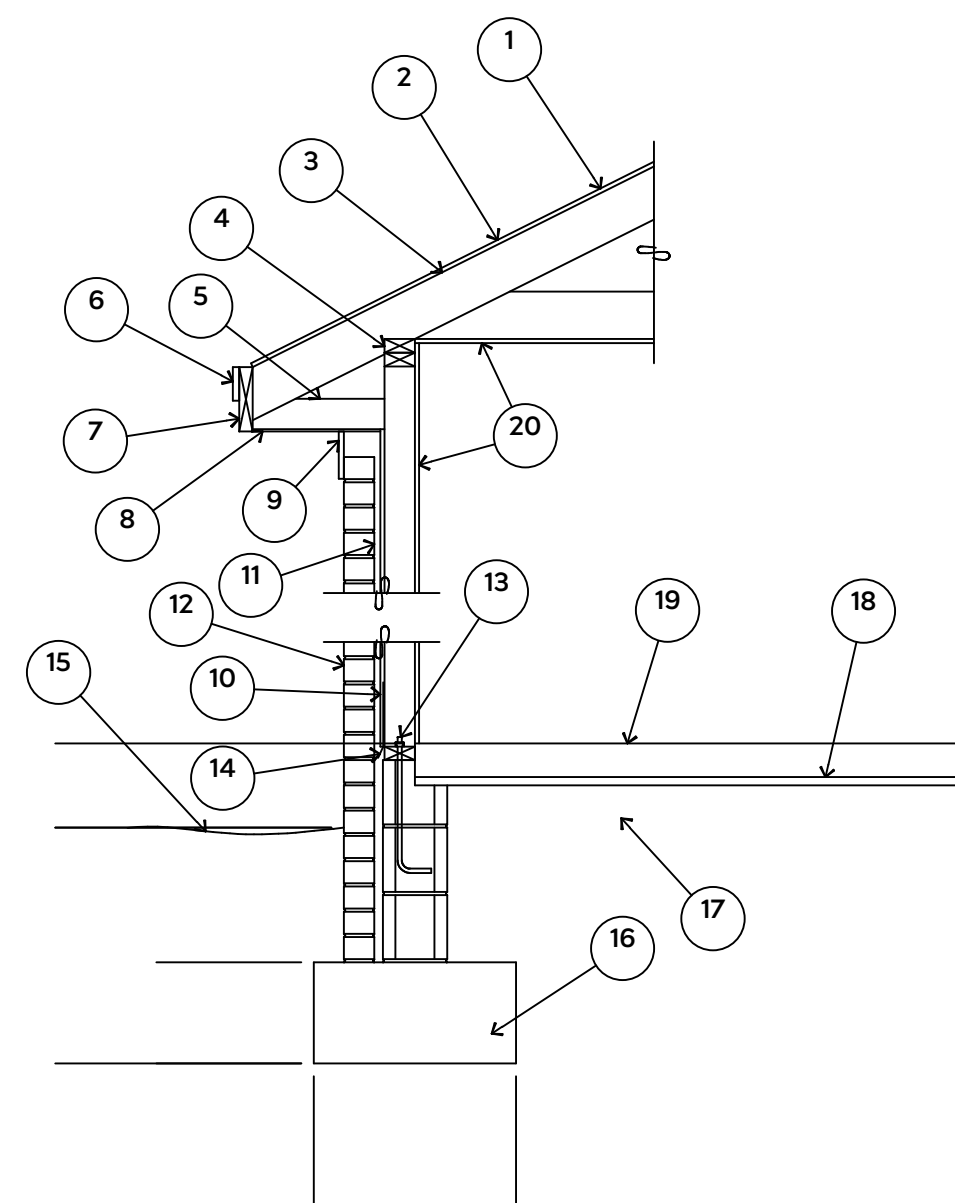

1. 15# FELT UNDERLAYMENT UNDER COMPOSITION SHINGLES.
2. ROOF DECKING.
3. 2 X RAFTERS / ENGINEERED TRUSSES
4. DOUBLE TOP PLATE.
5. 2 X 4 RETURN.
6. 3/4" FASCIA OR PVC TRIM COIL
7. 2 X FASCIA
8. 1/4" PLYWOOD OR VINYL SOFFIT
9. 1 X FREIZE BOARD (TO BE USED WITH BRICK VENEERS)
10. INSULATION BOARD OR HOUSE WRAP
11. AIR SPACE.
12. BRICK WITH BRICK TIES PER MANUFACTURER'S SPECIFICATIONS.
13. 1/2" X 12" ANCHOR BOLTS, 6'-0" O.C., 12" FROM CORNERS.
14. FLASHING WITH WEEP HOLES @ 48" O.C.
15. FINISHED GRADE.
16. FOOTING
17. COMPACTED EARTH FILL.
18. 6 MIL. VAPOR BARRIER
19. 4" CONCRETE SLAB, 3,000 P.S.I. WITH 6" X 6" 10 GA. X 10 GA. WELDED WIRE FABRIC.
20. 1/2" GYPSUM BOARD.

**EXTERIOR WALL SECTION**

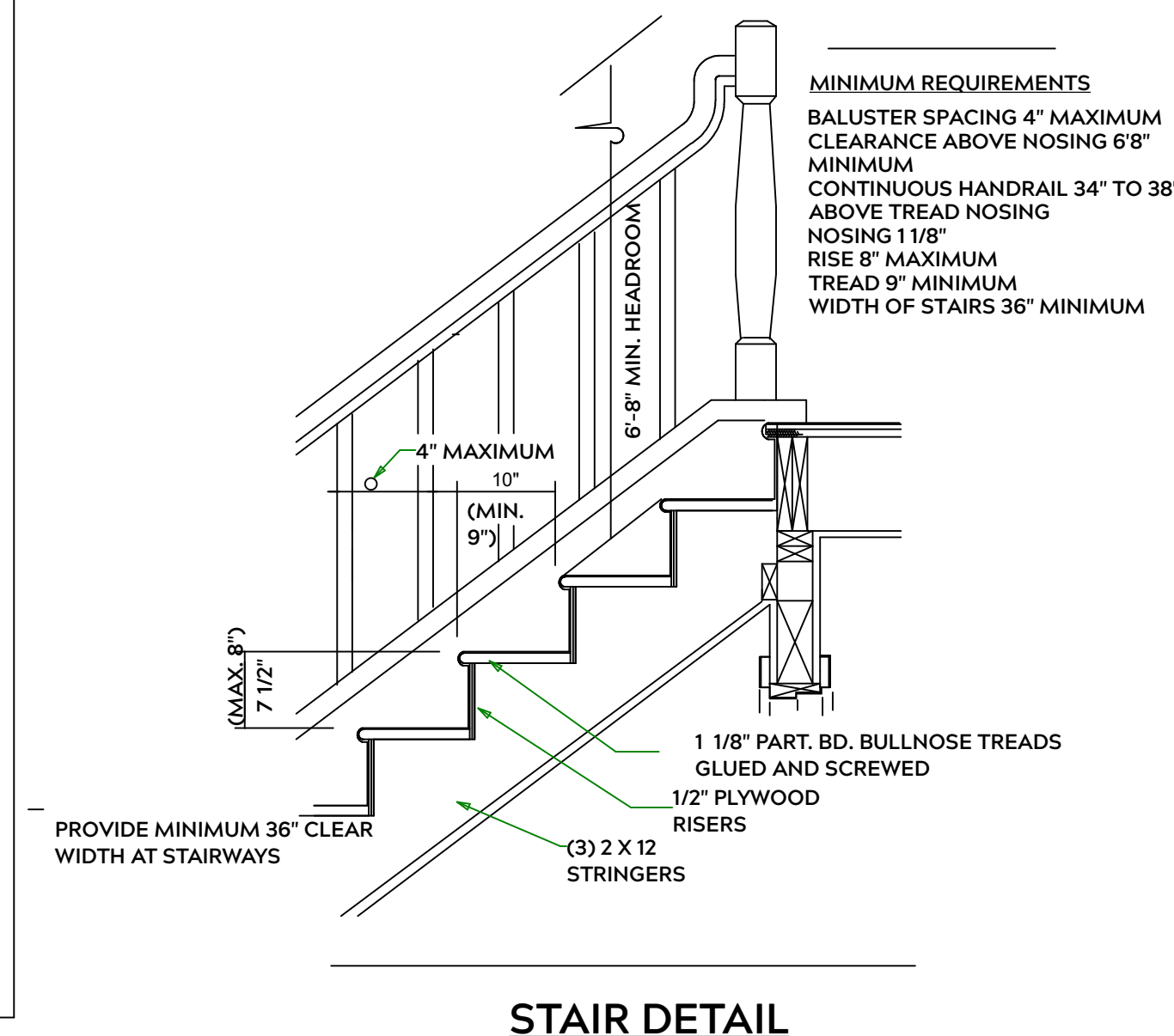

**STAIR DETAIL**



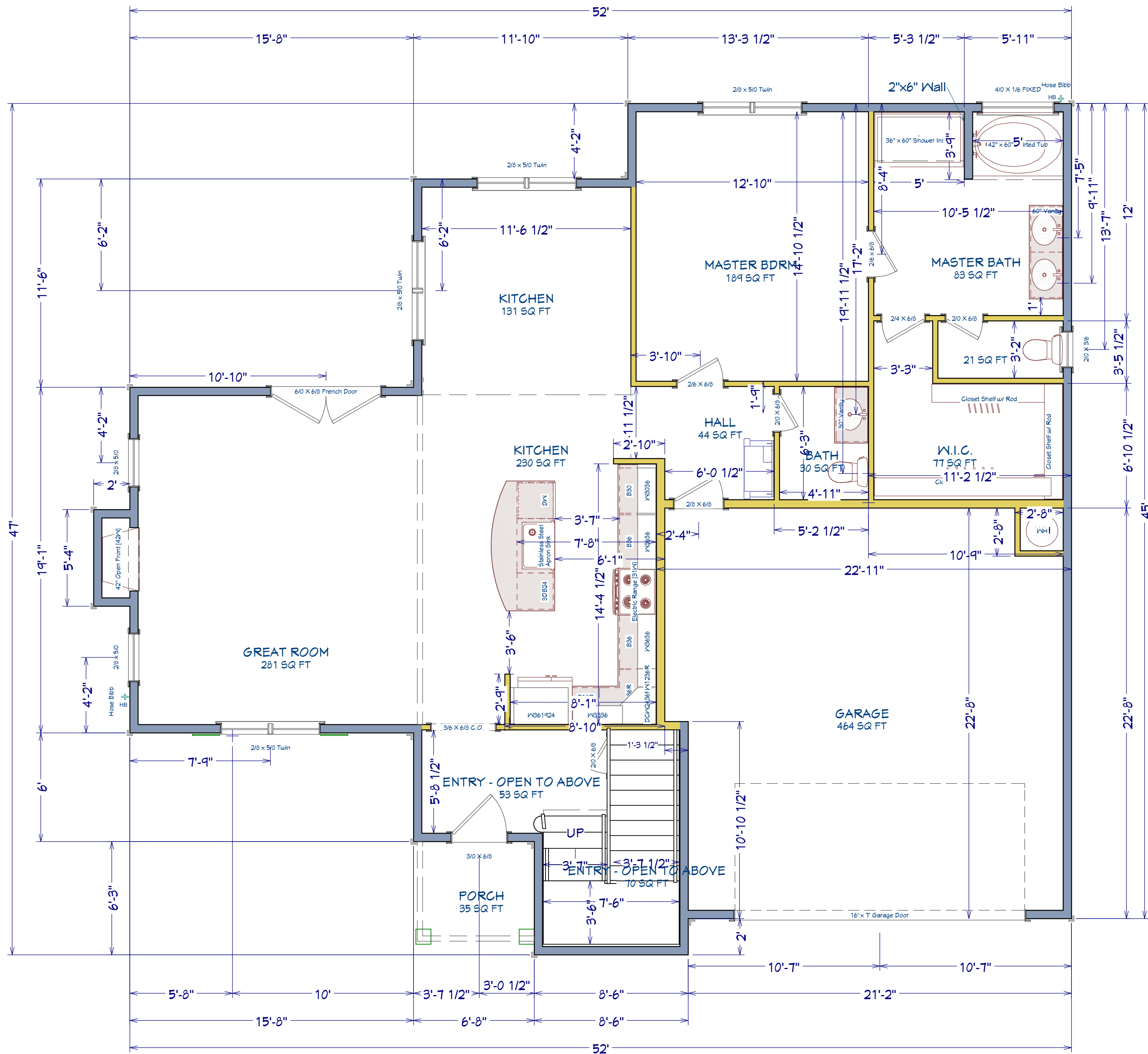

AREA SCHEDULE	
NAME	AREA
1st FLOOR	1,403 SF
2nd FLOOR	1,074 SF
<b>GARAGE</b>	
FRONT PORCH	35 SF
<b>TOTAL HEATED</b>	<b>2,477 SF</b>
<b>TOTAL UNDER ROOF</b>	<b>3,009 SF</b>

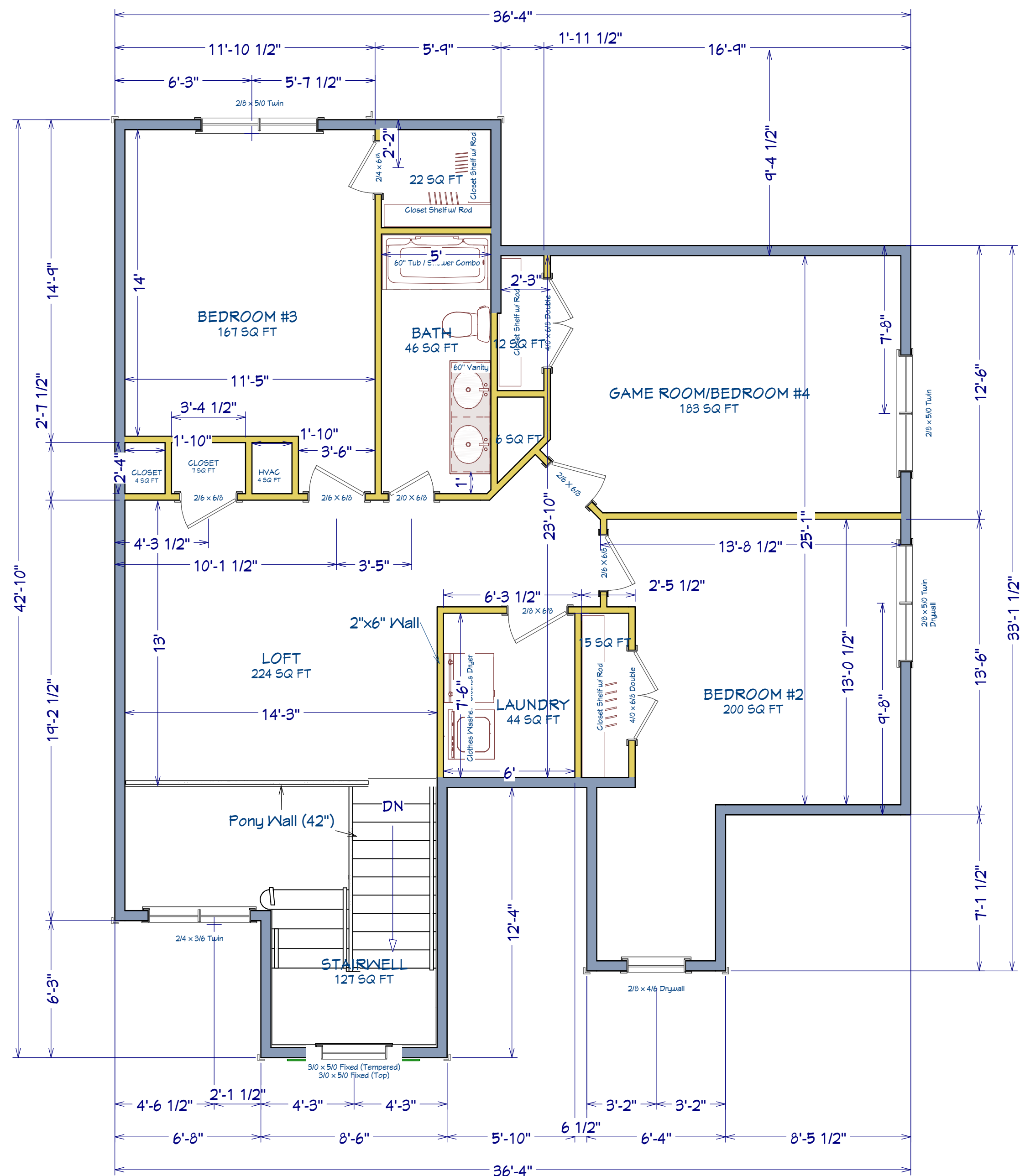

AREA SCHEDULE	
NAME	AREA
1st FLOOR	1,403 SF
2nd FLOOR	1,074 SF
<b>GARAGE</b>	
FRONT PORCH	35 SF
COVERED PORCH	183 SF
<b>TOTAL HEATED</b>	<b>2,477 SF</b>
<b>TOTAL UNDER ROOF</b>	<b>3,192 SF</b>

SHEET TITLE:

**2nd FLOOR**

**PROJECT ADDRESS:**  
145 Mahogany Ct.  
Magnolia Hills Lot 26

DESIGNED BY:  
Precision Custom Homes  
Raeferd, NC  
Shaun@PrecisionCustomHomesNC.com

DATE:

1/6/25

SCALE:

1/4" = 1'

SHEET:

**A-5**



# ROOF & FLOOR TRUSSES & BEAMS

Reilly Road Industrial Park  
Fayetteville, N.C. 28309  
Phone: (910) 864-8787  
Fax: (910) 864-4444

Bearing reactions less than or equal to 3000# are deemed to comply with the prescriptive Code requirements. The contractor shall refer to the attached Tables ( derived from the prescriptive Code requirements ) to determine the minimum foundation size and number of wood studs required to support reactions greater than 3000# but not greater than 15000#. A registered design professional shall be retained to design the support system for any reaction that exceeds those specified in the attached Tables. A registered design professional shall be retained to design the support system for all reactions that exceed 15000#.

Signature Neil Baggett

Neil Baggett

### LOAD CHART FOR JACK STUDS

(BASED ON TABLES R502.5(1) & (b))

NUMBER OF JACK STUDS REQUIRED @ EA END OF HEADER/GIRDER

END REACTION (UP TO)	REQ. STUDS FOR (1) FLY HEADER	END REACTION (UP TO)	REQ. STUDS FOR (1) FLY HEADER	END REACTION (UP TO)	REQ. STUDS FOR (1) FLY HEADER
1700	1	2550	1	3400	1
3400	2	5100	2	6800	2
5100	3	7650	3	10200	3
6800	4	10200	4	13600	4
8500	5	12750	5	17000	5
10200	6	15300	6		
11900	7				
13600	8				
15300	9				

**Dimension Notes**

- All exterior wall to wall dimensions are to face of sheathing unless noted otherwise
- All interior wall dimensions are to face of frame wall unless noted otherwise
- All exterior wall to truss dimensions are to face of frame wall unless noted otherwise

All Walls Shown Are Considered Load Bearing

**Plumbing Drop Notes**

- Plumbing drop locations shown are NOT exact.
- Contractor to verify ALL plumbing drop locations prior to setting Floor Trusses.
- Adjust spacing as needed not to exceed 24"oc.

Connector Information					Nail Information	
Sym	Product	Manuf	Qty	Supported Member	Header	Truss
●	HUS410	USP	28	NA	16d/3-1/2"	16d/3-1/2"

Products - Field Framed					
PlotID	Length	Product	Plies	Net Qty	
BM1	19' 0"	1-3/4"x 18" LVL Kerto-S	2	2	
BM2	5' 0"	1-3/4"x 14" LVL Kerto-S	2	2	
BM3	7' 0"	1-3/4"x 9-1/4" LVL Kerto-S	2	2	
GDH	22' 0"	1-3/4"x 18" LVL Kerto-S	2	2	

1 Truss Placement Plan  
Scale: 1/4"=1'

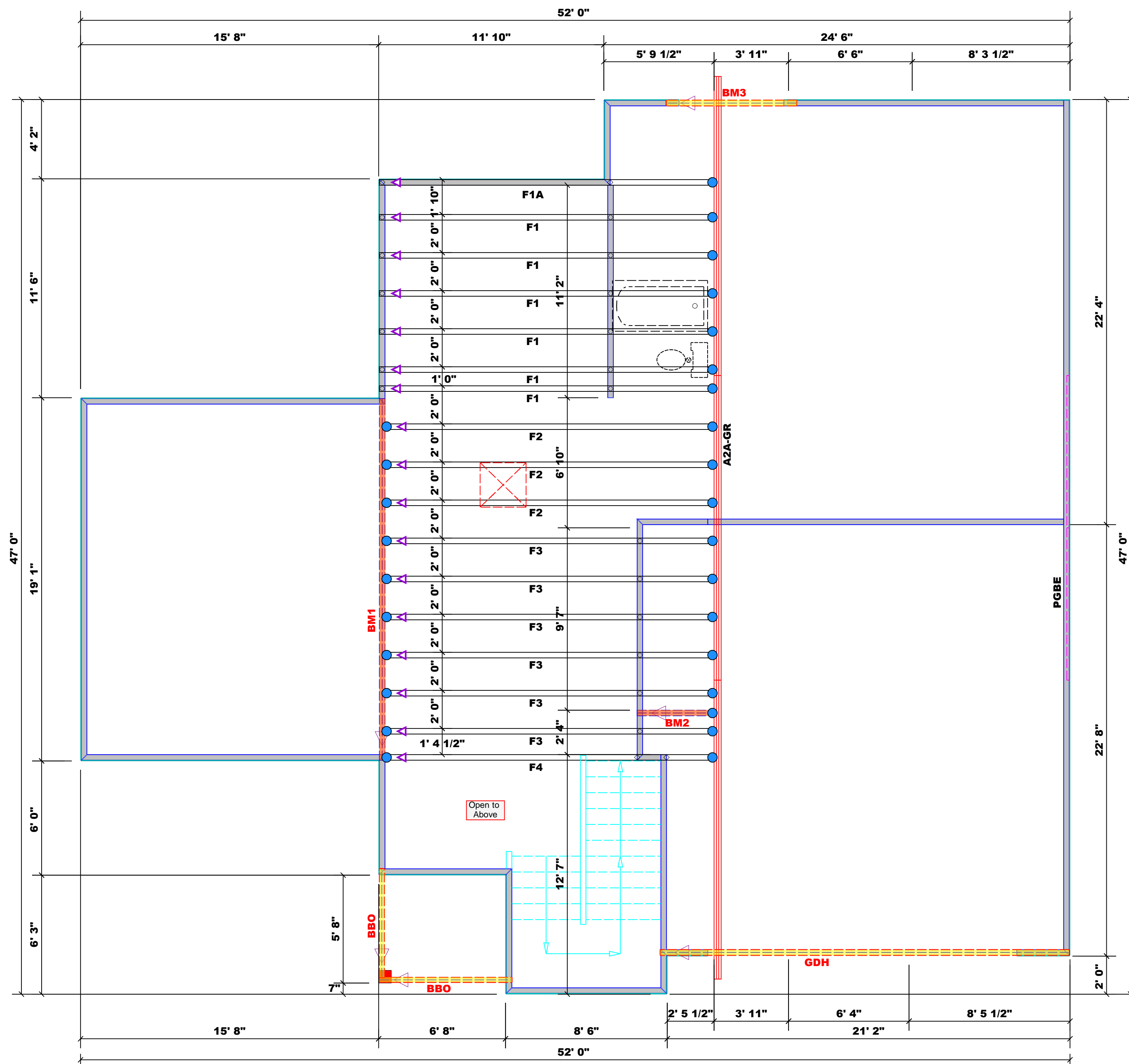

BUILDER	JOB NAME	PLAN	SEAL DATE	QUOTE #	JOB #
Precision Custom Homes and Renovations	Lot 26 Magnolia Hills	Anconia	Seal Date	Quote #	J1224-6955
CITY / CO.	ADDRESS	MODEL	DATE REV.	DRAWN BY	SALES REP.
Cameron / Harnett	Lot 26 Magnolia Hills	Floor	01/13/25	Neil Baggett	Neil Baggett

**▲ = Indicates Left End of Truss**  
**( Reference Engineered Truss Drawing )**  
**Do NOT Erect Truss Backwards**

THIS IS A TRUSS PLACEMENT DIAGRAM ONLY. These trusses are designed as individual building components to be incorporated into the building design at the specification of the building designer. See individual design sheets for each truss design identified on the placement drawing. The building designer is responsible for temporary and permanent bracing of the roof and floor system and for the overall structure. The design of the truss support structure including headers, beams, walls, and columns is the responsibility of the building designer. For general guidance regarding bracing, consult BCSI-B1 and BCSI-B3 provided with the truss delivery package or online @ sbcindustry.com





# North Carolina 2018 - R402.1.5 Total UA



**Property**

32 Brewster Ct  
Cameron, NC 28326  
Model: Anconia  
Community: Liberty Meadows

**Organization**

Southern Energy Manager  
Justin Smith

**Inspection Status**

Results are projected

**Builder**

SMG Precision Properties

Template - SMG Precision - Liberty  
Meadows Lot 33 - CZ 4 slab -  
Liberty Meadows Lot 33

**This report is based on a proposed design and does not confirm field enforcement of design elements.**

## Building UA

Elements	NC Reference	As Designed
Ceilings	52.2	49.6
Above-Grade Walls	219.5	163.0
Windows, Doors and Skylights	122.3	110.4
Slab Floor:	95.1	123.3
Framed Floors	15.8	17.2
Foundation Walls	0.0	0.0
Rim Joists	7.4	6.0
<b>Overall UA (Design must be equal or lower):</b>	<b>512.3</b>	<b>469.5</b>

## Requirements

✓	R402.1.5	Total UA alternative compliance passes by 8.4%. The proposed home meets the UA requirement by 8.4%
✓	402.3.2	Average SHGC: 0.28 Max SHGC: 0.30 Average SHGC of 0.28 is greater than the maximum of 0.30.
✓	R402.4.2.2	Air Leakage Testing Air sealing is 0.27 CFM50 / ft² Shell Area. It must not exceed 0.30 CFM50 / ft² Shell Area.
✓	R402.5	Area-weighted average fenestration SHGC Area-weighted average fenestration SHGC is 0.28. The maximum allowed value is [No Limit].
✓	R402.5	Area-weighted average fenestration U-Factor
✓	R404.1	Lighting Equipment At least 75.0% of fixtures shall be high-efficacy lamps, currently 100.0% are high-efficacy.
✓	Mandatory Checklist	Mandatory code requirements that are not checked by Ekotrope must be met. 2015 IECC Mandatory Checklist must be checked as complete.
✓	R403.3.1	Duct Insulation Duct insulation meets the requirements specified in North Carolina 2018 Code Section 403.3.1.
✓	403.3.3	Duct Testing

**Design exceeds requirements for North Carolina 2018 Prescriptive compliance by 8.4%.**

Name: Justin Smith  
Organization: Southern Energy Management

Signature: Justin Smith  
Digitally signed: 2/1/23 at 10:15 AM

Ekotrope RATER - Version 4.0.2.3086

North Carolina 2018 Prescriptive compliance results calculated using Ekotrope RATER's energy and code compliance algorithm, including appropriate amendments. Ekotrope RATER is a RESNET Accredited HERS Rating Tool. All results are based on data entered by Ekotrope users. Ekotrope disclaims all liability for the information shown on this report.



# Building Summary



**SOUTHERN ENERGY**  
MANAGEMENT  
ENERGY EFFICIENCY & SOLAR POWER

## Property

32 Brewster Ct  
Cameron, NC 28326  
Model: Anconia  
Community: Liberty Meadows

## Organization

Southern Energy Management  
Justin Smith

## Inspection Status

Results are projected

## Builder

SMG Precision Properties

Template - SMG Precision - Liberty Meadows Lot 33  
- CZ 4 slab - ecoSelect  
Liberty Meadows Lot 33

## General Building Information

Number Of Bedrooms	4
Number Of Floors	2
Conditioned Floor Area [sq. ft.]	2,477
Has Electric Vehicle Ready Space	No
Unconditioned, attached garage?	Yes
Conditioned Volume [cu. ft.]	22,622
Total Units in Building	1
Residence Type	Single family detached
Number of Floors in Building	-
Floor Number	-
Model	Anconia
Community	Liberty Meadows
RESNET/IECC 2006-2018 Climate Zone	4A
IECC 2021 Climate Zone	3A

## Foundation Wall

None Present

## Foundation Wall Library List

None Present

## Slab

Name	Library Type	Perimeter	Floor Grade	Carpet R	Exposed Masonry Area	Surface Area	Location	Enclosing
slab	Uninsulated	200	On Grade	1	0	1,403.0 ft²	Exposed Exterior	Conditioned Space

## Slab Library List

Name	Wall Construction Type	Slab Completely Insulated?	Underslab Insulation Width [ft]	Perimeter Insulation Depth [ft]	Perimeter Insulation R Value	Thermal Break	Effective R-value
Uninsulated	Wood Frame / Other	No	0	0	0	No	0.00

# Building Summary



**Property**  
 32 Brewster Ct  
 Cameron, NC 28326  
 Model: Anconia  
 Community: Liberty Meadows

**Organization**  
 Southern Energy Management  
 Justin Smith

**Inspection Status**  
 Results are projected

**SOUTHERN ENERGY MANAGEMENT**  
 ENERGY EFFICIENCY & SOLAR POWER

Template - SMG Precision - Liberty Meadows Lot 33  
 - CZ 4 slab - ecoSelect  
 Liberty Meadows Lot 33

Framed Floor					
Name	Library Type	Carpet R	Floor Grade	Surface Area	Location
over garage	R 19, 16"OC G1 Carpet	0	Above Grade	337.0 ft <sup>2</sup>	Unconditioned, attached garage

Framed Floor Library List	
Name	Effective R-value
R 19, 16"OC G1 Carpet	19.566

Rim Joist			
Name	Library Type	Surface Area	Location
1st floor ambient	R 19 G1, 16"OC	87.0 ft <sup>2</sup>	Exposed Exterior
1st floor garage	R 19 G1, 16"OC	47.0 ft <sup>2</sup>	Unconditioned, attached garage

Rim Joist Library List	
Name	Effective Insulation R-value
R 19 G1, 16"OC	17.30

Wall				
Name	Library Type	Surface Color	Surface Area	Location
1st floor ambient	R 19 Adv. Framing G1 16" O.C	Medium	1,381.0 ft <sup>2</sup>	Exposed Exterior
1st floor garage	R 19 Adv. Framing G1 16" O.C	Medium	419.0 ft <sup>2</sup>	Unconditioned, attached garage
2nd floor ambient	R 19 Adv. Framing G1 16" O.C	Medium	694.0 ft <sup>2</sup>	Exposed Exterior
2nd floor attic	R 19 Adv. Framing G1 16" O.C	Medium	706.0 ft <sup>2</sup>	Attic

# Building Summary



**Property**  
 32 Brewster Ct  
 Cameron, NC 28326  
 Model: Anconia  
 Community: Liberty Meadows

**Organization**  
 Southern Energy Management  
 Justin Smith

**Inspection Status**  
 Results are projected

**SOUTHERN ENERGY MANAGEMENT**  
 ENERGY EFFICIENCY & SOLAR POWER

Template - SMG Precision - Liberty Meadows Lot 33  
 - CZ 4 slab - ecoSelect  
 Liberty Meadows Lot 33

**Builder**  
 SMG Precision Properties

## Wall Library List

Name	Effective R-value
R 19 Adv. Framing G1 16" O.C	17.492

## Glazing

Name	Library Type	Wall Assignment	Foundation Wall Assignment	Is Operable	Overhang Depth	Overhang Ft To Top	Overhang Ft To Bottom	Orientation	Surface Area
front 2nd unshaded	33/28	2nd floor ambient		Yes	0	0	0	Southeast	42.2 ft²
front unshaded	33/28	1st floor ambient		Yes	0	0	0	Southeast	27.0 ft²
left shaded	33/28	1st floor ambient		Yes	15	1	6	Southwest	27.0 ft²
left unshaded	33/28	1st floor ambient		Yes	0	0	0	Southwest	27.0 ft²
rear 2nd unshaded	33/28	2nd floor ambient		Yes	0	0	0	Northwest	27.0 ft²
rear shaded	33/28	1st floor ambient		Yes	12	2	9	Northwest	40.2 ft²
rear unshaded	33/28	1st floor ambient		Yes	0	0	0	Northwest	60.0 ft²
right 2nd unshaded	33/28	2nd floor ambient		Yes	0	0	0	Northeast	54.0 ft²
right unshaded	33/28	1st floor ambient		Yes	0	0	0	Northeast	7.0 ft²

## Glazing Library List

Name	Shgc	U-factor
33/28	0.28	0.330

## Skylight

None Present

# Building Summary



**Property**  
 32 Brewster Ct  
 Cameron, NC 28326  
 Model: Anconia  
 Community: Liberty Meadows

**Organization**  
 Southern Energy Management  
 Justin Smith

**Inspection Status**  
 Results are projected

**SOUTHERN ENERGY MANAGEMENT**  
 ENERGY EFFICIENCY & SOLAR POWER

Template - SMG Precision - Liberty Meadows Lot 33  
 - CZ 4 slab - ecoSelect  
 Liberty Meadows Lot 33

## Skylight Library List

None Present

## Opaque Door

Name	Library Type	Wall Assignment	Foundation Wall Assignment	Emittance	Solar Absorptance	Surface Color	Surface Area	Location
front entry	Fiberglass R-5	1st floor ambient		0.9	0.75	Medium	20.0 ft²	Exposed Exterior
garage entry	Fiberglass R-5	1st floor garage		0.9	0.75	Medium	18.0 ft²	Unconditioned, attached garage

## Opaque Door Library List

Name	Effective U-factor
Fiberglass R-5	0.200

## Roof Insulation

Name	Library Type	Attic Exterior Area [ft²]	Clay or Concrete Roof Tiles	Surface Color	Surface Area	Location
attic	R 38 Attic BLOWN FG G1 2x10 24"OC NO Radiant Barrier	2,557.8	No	Dark	1,740.0 ft²	Attic

## Roof Insulation Library List

Name	Has Radiant Barrier	Effective R-value
R 38 Attic BLOWN FG G1 2x10 24"OC NO Radiant Barrier	No	35.115

## Whole House Infiltration

Infiltration	Measurement Type	Shelter Class
1809 CFM at 50 Pa	Blower-door tested	4



# Building Summary



**Property**  
32 Brewster Ct  
Cameron, NC 28326  
Model: Anconia  
Community: Liberty Meadows

**Organization**  
Southern Energy Management  
Justin Smith

**Inspection Status**  
Results are projected

**Builder**  
SMG Precision Properties

Template - SMG Precision - Liberty Meadows Lot 33  
- CZ 4 slab - ecoSelect  
Liberty Meadows Lot 33

## Mechanical Ventilation

None Present

## Lighting

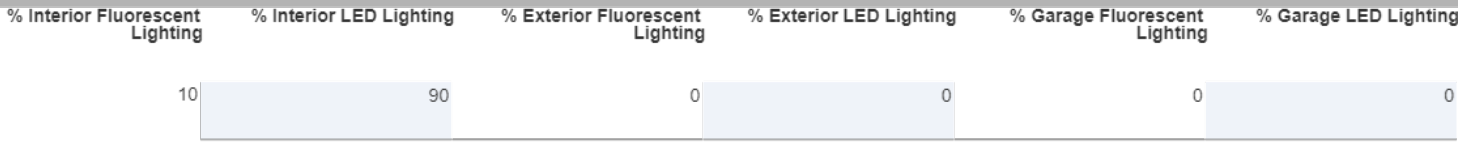

## Onsite Generation

None Present

## Onsite Generation Library List

None Present

## Solar Generation

None Present

## Dehumidifier

None Present

## Dehumidifier Library List

None Present

# Building Summary



**Property**  
 32 Brewster Ct  
 Cameron, NC 28326  
 Model: Anconia  
 Community: Liberty Meadows

**Organization**  
 Southern Energy Management  
 Justin Smith

**Inspection Status**  
 Results are projected

**Builder**  
 SMG Precision Properties

Template - SMG Precision - Liberty Meadows Lot 33  
 - CZ 4 slab - ecoSelect  
 Liberty Meadows Lot 33

## Whole House Fan

None Present

## Whole House Fan Library List

None Present

## Conditioning Equipment

Name	Library Type	Serial Number	Heating Percent Load	Cooling Percent Load	Hot Water Percent Load	Location
1st floor heat pump	z 24k 14 SEER 8.2hspf		57%	57%	0%	Attic
2nd floor heat pump	z 30k 14 SEER 8.2hspf		43%	43%	0%	Attic
Water Heating	z 50 gal. 0.95 EF Elec		0%	0%	100%	Unconditioned Garage

## Equipment Type: z 24k 14 SEER 8.2hspf

Equipment Type	Air Source Heat Pump
Fuel Type	Electric
Distribution Type	Forced Air
Motor Type	PSC (Single Speed)
Heating Efficiency	8.2 HSPF
Heating Capacity [kBtu/h]	24
Backup Fuel Type	Electric
Switchover Temperature [°F]	0
Backup Heating Efficiency	1 COP
Use default Supplemental Heat	Yes
Cooling Efficiency	14 SEER
Cooling Capacity [kBtu/h]	24

# Building Summary



**Property**  
32 Brewster Ct  
Cameron, NC 28326  
Model: Anconia  
Community: Liberty Meadows

**Organization**  
Southern Energy Management  
Justin Smith

**Inspection Status**  
Results are projected

Template - SMG Precision - Liberty Meadows Lot 33  
- CZ 4 slab - ecoSelect  
Liberty Meadows Lot 33

**Builder**  
SMG Precision Properties

## Equipment Type: z 30k 14 SEER 8.2hspf

Equipment Type	Air Source Heat Pump
Fuel Type	Electric
Distribution Type	Forced Air
Motor Type	PSC (Single Speed)
Heating Efficiency	8.2 HSPF
Heating Capacity [kBtu/h]	30
Backup Fuel Type	Electric
Switchover Temperature [°F]	0
Backup Heating Efficiency	1 COP
Use default Supplemental Heat	Yes
Cooling Efficiency	14 SEER
Cooling Capacity [kBtu/h]	30

## Equipment Type: z 50 gal. 0.95 EF Elec

Equipment Type	Residential Water Heater
Fuel Type	Electric
Distribution Type	Hydronic Delivery (Radiant)
Hot Water Efficiency	0.95 Energy Factor
Tank Capacity (gal.)	50
Hot Water Capacity [kBtu/h]	40
Recovery Efficiency	0.98

# Building Summary



**Property**  
 32 Brewster Ct  
 Cameron, NC 28326  
 Model: Anconia  
 Community: Liberty Meadows

**Organization**  
 Southern Energy Management  
 Justin Smith

**Inspection Status**  
 Results are projected

**Builder**  
 SMG Precision Properties

Template - SMG Precision - Liberty Meadows Lot 33  
 - CZ 4 slab - ecoSelect  
 Liberty Meadows Lot 33

## Distribution System

Distribution Type	Forced Air
Heating Equipment	1st floor heat pump
Cooling Equipment	1st floor heat pump
Sq. Feet Served	1,403
# Return Grilles	2
Supply Duct R Value	8
Return Duct R Value	8
Supply Duct Area [ft <sup>2</sup> ]	378.81
Return Duct Area [ft <sup>2</sup> ]	140.3
Leakage to Outdoors	56 CFM @ 25Pa (3.99 / 100 ft <sup>2</sup> )
Total Leakage	56 CFM25
Total Leakage Duct Test Conditions	Post-Construction
Use Default Flow Rate	Yes
Duct 1	
Duct Location	Attic (well vented)
Percent Supply Area	100
Percent Return Area	100
Duct 2	
Duct Location	Conditioned Space
Percent Supply Area	0
Percent Return Area	0
Duct 3	
Duct Location	Conditioned Space
Percent Supply Area	0
Percent Return Area	0
Duct 4	
Duct Location	Conditioned Space
Percent Supply Area	0
Percent Return Area	0
Duct 5	
Duct Location	Conditioned Space
Percent Supply Area	0
Percent Return Area	0
Duct 6	
Duct Location	Conditioned Space
Percent Supply Area	0
Percent Return Area	0



# Building Summary



**SOUTHERN ENERGY**  
MANAGEMENT  
ENERGY EFFICIENCY & SOLAR POWER

**Property**

32 Brewster Ct  
Cameron, NC 28326  
Model: Anconia  
Community: Liberty Meadows

**Organization**

Southern Energy Management  
Justin Smith

**Inspection Status**

Results are projected

**Builder**

SMG Precision Properties

Template - SMG Precision - Liberty Meadows Lot 33  
- CZ 4 slab - ecoSelect  
Liberty Meadows Lot 33

## Distribution System

Distribution Type	Forced Air
Heating Equipment	2nd floor heat pump
Cooling Equipment	2nd floor heat pump
Sq. Feet Served	1,074
# Return Grilles	2
Supply Duct R Value	8
Return Duct R Value	8
Supply Duct Area [ft <sup>2</sup> ]	289.98
Return Duct Area [ft <sup>2</sup> ]	107.4
Leakage to Outdoors	42 CFM @ 25Pa (3.91 / 100 ft <sup>2</sup> )
Total Leakage	42 CFM25
Total Leakage Duct Test Conditions	Post-Construction
Use Default Flow Rate	Yes
Duct 1	
Duct Location	Attic (well vented)
Percent Supply Area	100
Percent Return Area	100
Duct 2	
Duct Location	Conditioned Space
Percent Supply Area	0
Percent Return Area	0
Duct 3	
Duct Location	Conditioned Space
Percent Supply Area	0
Percent Return Area	0
Duct 4	
Duct Location	Conditioned Space
Percent Supply Area	0
Percent Return Area	0
Duct 5	
Duct Location	Conditioned Space
Percent Supply Area	0
Percent Return Area	0
Duct 6	
Duct Location	Conditioned Space
Percent Supply Area	0
Percent Return Area	0

## HVAC Grading

HVAC Grading Not Conducted

## Ceiling Fan

Has Ceiling Fan	No
Cfm Per Watt	100

# Building Summary



## Property

32 Brewster Ct  
Cameron, NC 28326  
Model: Anconia  
Community: Liberty Meadows

## Organization

Southern Energy Management  
Justin Smith

## Inspection Status

Results are projected

Template - SMG Precision - Liberty Meadows Lot 33  
- CZ 4 slab - ecoSelect  
Liberty Meadows Lot 33

## Builder

SMG Precision Properties

## Water Distribution

Water Fixture Type	Low-flow
Use Default Hot Water Pipe Length	No
Hot Water Pipe Length [ft]	100
At Least R3 Pipe Insulation?	No
Hot Water Recirculation System?	No
Recirculation System Pipe Loop Length [ft]	20
Drain Water Heat Recovery?	No

## Clothes Dryer

Cef	3.01
Fuel Type	Electric
Field Utilization	Timer Controls
Is Outside Conditioned Space	No
Clothes Dryer Available	Yes
Defaults Type	HERS Reference

## Clothes Washer

Label Energy Rating	153 kWh/Year
Annual Gas Cost	\$12.00
Electric Rate	\$0.11/kWh
Gas Rate	\$1.22/Therm
Capacity	3.31
Imef	2.1547
Defaults Type	Custom
Load Type	Front-load
Loads Per Week	6
Is Outside Conditioned Space	No
Clothes Washer Available	Yes

## Dishwasher

Dishwasher Efficiency	270 kWh
Dishwasher Size	Standard
Annual Gas Cost	\$22.23
Electric Rate	\$0.12/kWh
Gas Rate	\$1.09/Therm
Is Outside Conditioned Space	No

# Building Summary



**Property**  
32 Brewster Ct  
Cameron, NC 28326  
Model: Anconia  
Community: Liberty Meadows

**Organization**  
Southern Energy Management  
Justin Smith

**Inspection Status**  
Results are projected

Template - SMG Precision - Liberty Meadows Lot 33  
- CZ 4 slab - ecoSelect  
Liberty Meadows Lot 33

**Builder**  
SMG Precision Properties

## Appliances and Controls

Thermostat Cooling Setpoint	*** 75.0
Thermostat Heating Setpoint	*** 70.0
Range/Oven Fuel	Electric
Convection Oven?	No
Induction Range?	No
Range/Oven Outside Conditioned Space?	No
Refrigerator Consumption	538 kWh/Year
Refrigerator Outside Conditioned Space?	No

## Notes

Initial Inputs \_\_\_\_\_ JS 02/01/22\_\_\_\_\_

- confirm HVAC specs
- confirm water heater specs
- confirm ventilation entry
- modeled to worst case orientation
- confirm cfl lighting %