



FRONT ELEVATION

Scale: 1/4" = 1'0"

9'0" CEILING HEIGHT FIRST FLOOR
(HEADER HEIGHT 7'6")
8'0" CEILING HEIGHT SECOND FLOOR
(Frame Headers to Top Plates)

FRAME WINDOWS TO HEADER HEIGHT



LEFT ELEVATION

Scale: 1/8" = 1'0"

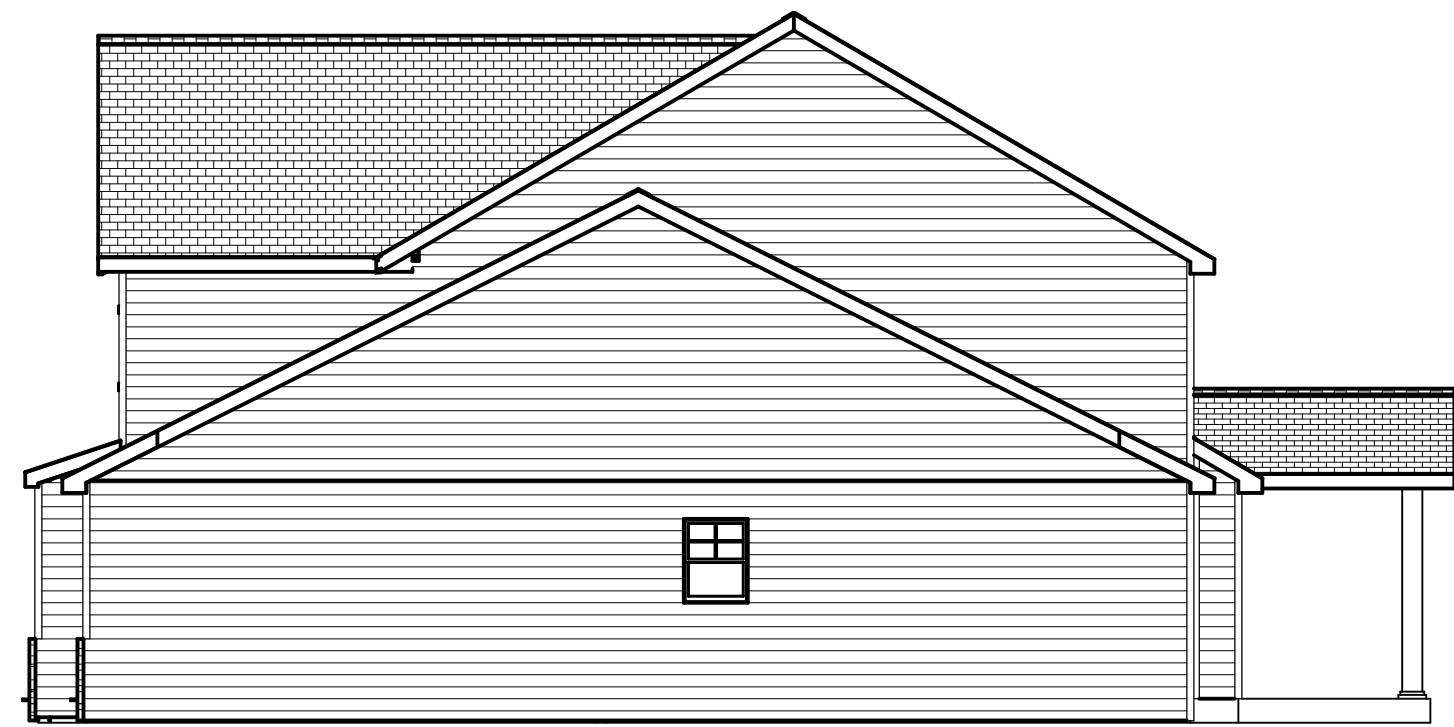

RIGHT ELEVATION

Scale: 1/8" = 1'0"



REAR ELEVATION

Scale: 1/8" = 1'0"

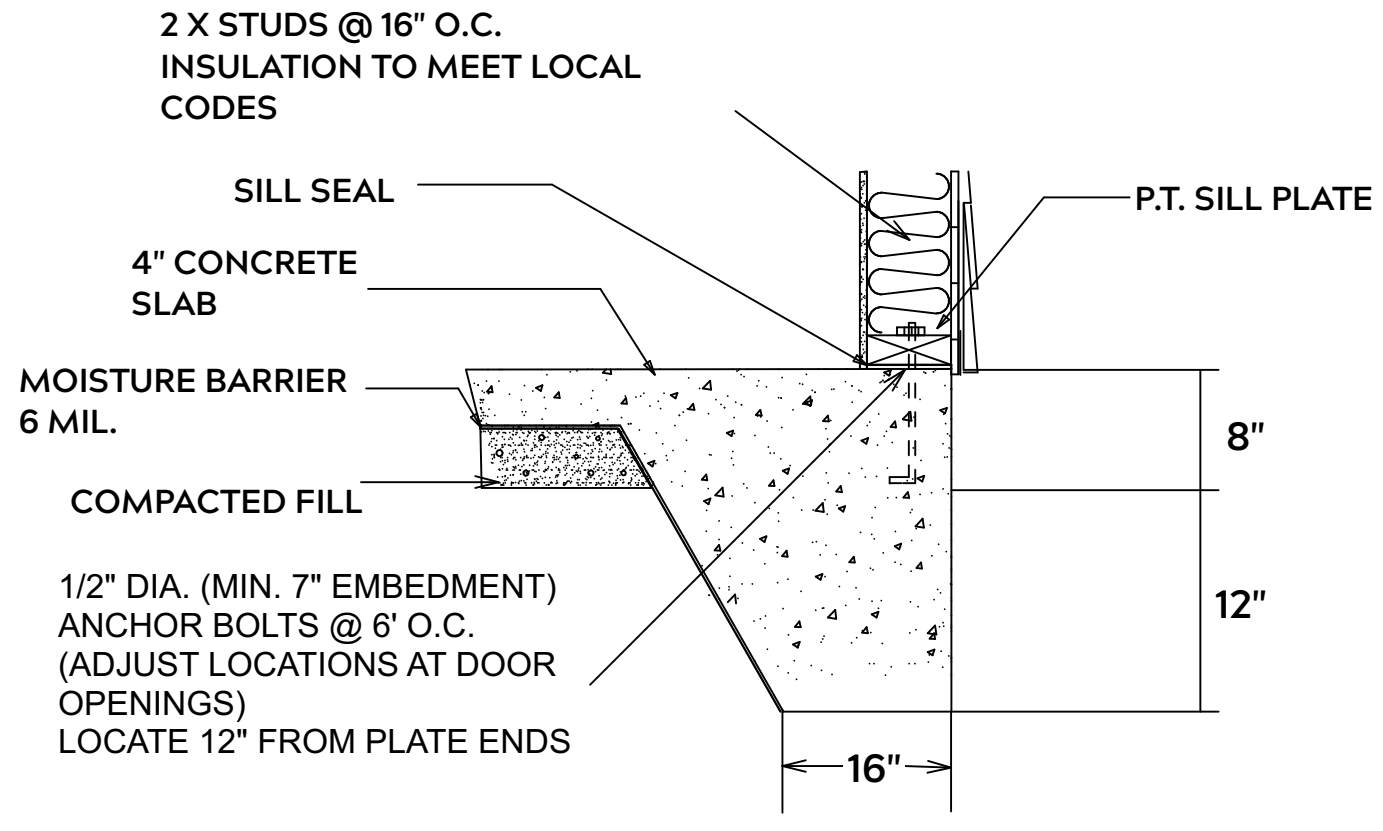

MONOLITHIC SLAB

FOUNDATION NOTES:

ALL FOOTINGS SHALL BEAR ON ORIGINAL UNDISTURBED SOIL
THE 28 DAY COMPRESSIVE STRENGTH OF ALL FOOTINGS IS 3000 PSI

PROVIDE WATER PROOFING AND PERIMTER DRAINS AS REQUIRED

FOOTING WIDTHS ARE BASED ON A LOAD BEARING SOIL CAPACITY OF 2000 PSI

PROVIDE 6 MIL POLY VAPOR BARRIER TO COVER GROUND IN CRAWL SPACE AND GROUND UNDER POURED CONCRETE

ALL ANCHOR BOLTS TO BE 1/2" X 12" LONG. ANCHOR BOLTS SHALL BE SPACED AT A MAXIMUM OF 6' ON CENTER AND NO MORE THEN 1' FROM EACH CORNER

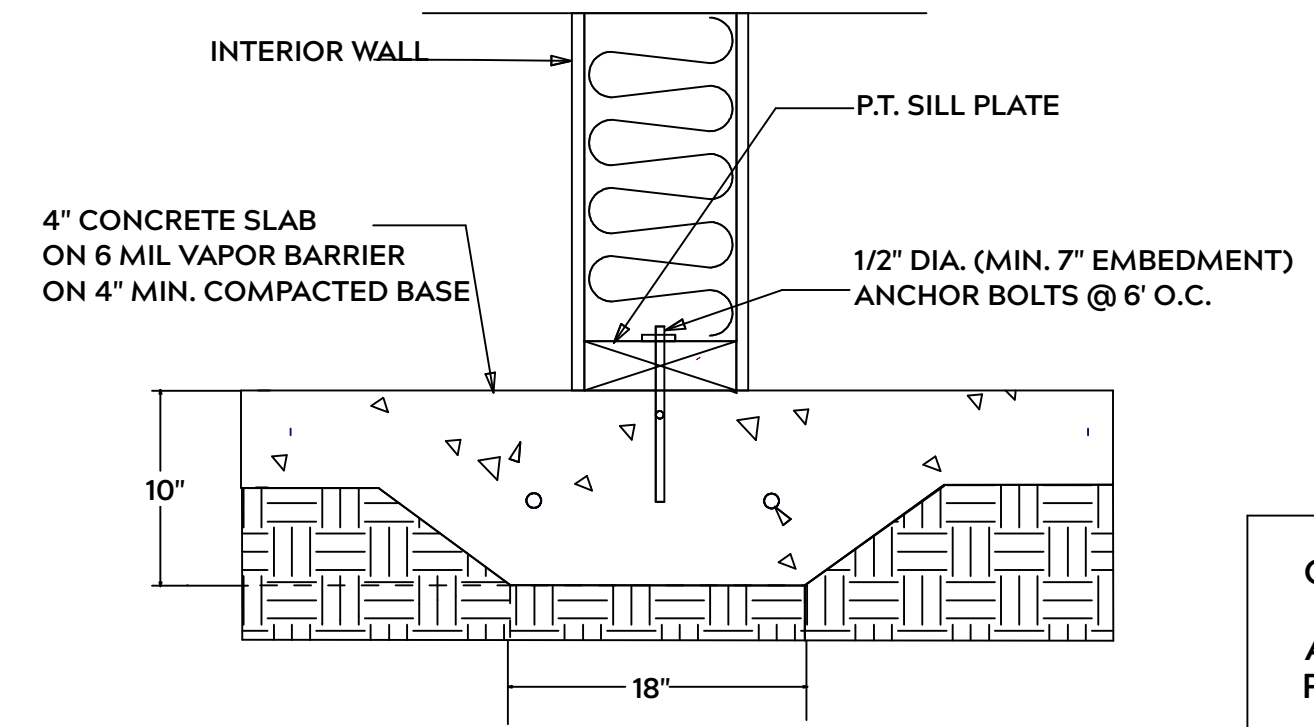

LUG FOOTING

GENERAL FRAMING NOTES:

ALL LUMBER IN CONTACT WITH CONCRETE OR MASONRY SHALLE BE PRESSURE TREATED

FRAMING LUMBER SHALL BE SYP #2 GRADE AND / OR SPRUCE PINE FIR #1 AND / OR KILN DRIED

WHERE PRE-ENGINEERED JOISTS AND TRUSSES ARE USED, MANUFACTURER SHALL PROVIDE DRAWINGS / SCHEMATICS, WHICH SHALL BEAR OF A N.C. ENGINEER

STUDS AND JOISTS SHALL NOT BE CUT TO INSTALL PLUMBING OR WIRING WITHOUT ADDING METAL OR WOOD SIDE PANELS TO STRENGTHEN MEMBER TO ITS ORIGINAL CAPACITY

NAIL MULTIPLE MEMBERS WITH 2 ROWS OF 16d NAILS STAGGERED 32" O.C. AND USE 3 X 16d NAILS 2" IN AT EACH END.

NAIL FLOOR JOISTS TO SILL PLATE WITH WITH 8d TOE NAILS

ALL EXPOSED FRAMING ON PORCHES OR DECKS SHALL BE PRESSURE TREATED

PROVIDE WATERPROOFING AND DRAINS AS REQUIRED

ALL FRAMING TO BE 16" O.C. WALL FRAMING DIMENSIONS ARE BASED ON 2X4 OR 2X6 EXTERIOR WALLS AND 2X4 INTERIOR WALLS. DOULBE / TRIPLE JACK STUDS AS NECESSARY UNDER HEADERS AS REQUIRED

LVL'S TO BE SIZED BY OTHERS (TRUSS MANUFACTURER)

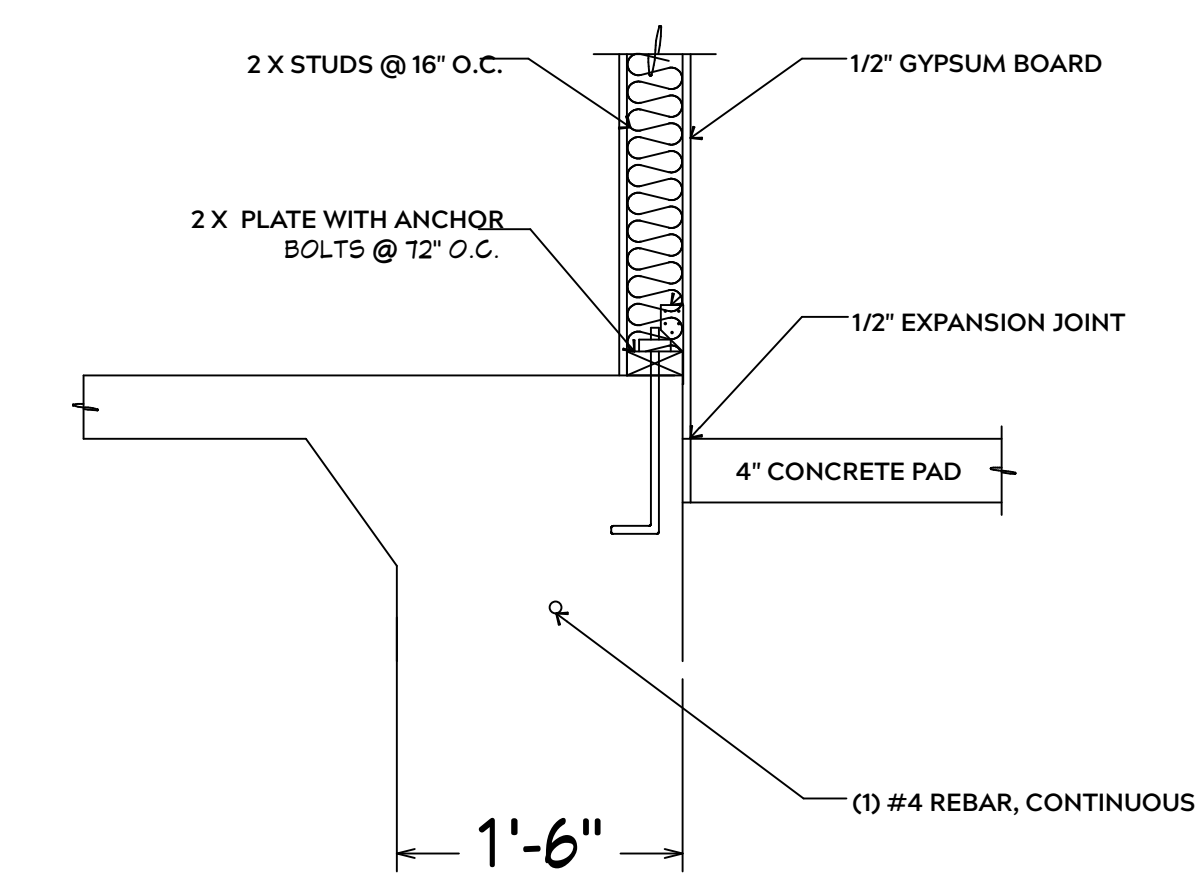

INTERIOR WALL @ GARAGE STEP DOWN

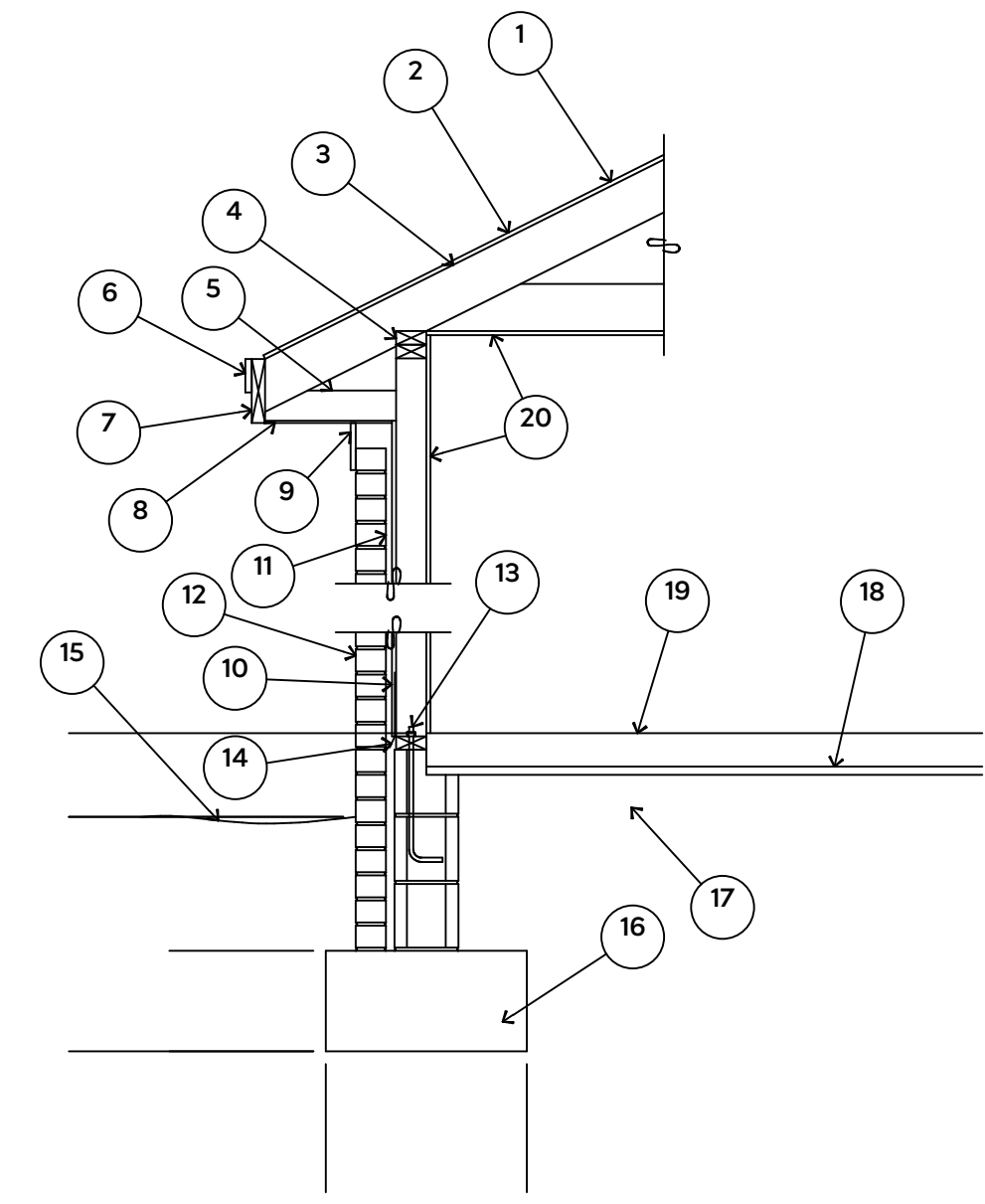

1. 15# FELT UNDERLAYMENT UNDER COMPOSITION SHINGLES.
2. ROOF DECKING.
3. 2 X RAFTERS / ENGINEERED TRUSSES
4. DOUBLE TOP PLATE.
5. 2 X 4 RETURN.
6. 3/4" FASCIA OR PVC TRIM COIL
7. 2 X FASCIA
8. 1/4" PLYWOOD OR VINYL SOFFIT
9. 1 X FREIZE BOARD (TO BE USED WITH BRICK VENEERS)
10. INSULATION BOARD OR HOUSE WRAP
11. AIR SPACE.
12. BRICK WITH BRICK TIES PER MANUFACTURER'S SPECIFICATIONS.
13. 1/2" X 12" ANCHOR BOLTS, 6'-0" O.C., 12" FROM CORNERS.
14. FLASHING WITH WEEP HOLES @ 48" O.C.
15. FINISHED GRADE.
16. FOOTING
17. COMPACTED EARTH FILL.
18. 6 MIL. VAPOR BARRIER
19. 4" CONCRETE SLAB, 3,000 P.S.I. WITH 6" X 6" 10 GA. X 10 GA. WELDED WIRE FABRIC.
20. 1/2" GYPSUM BOARD.

EXTERIOR WALL SECTION

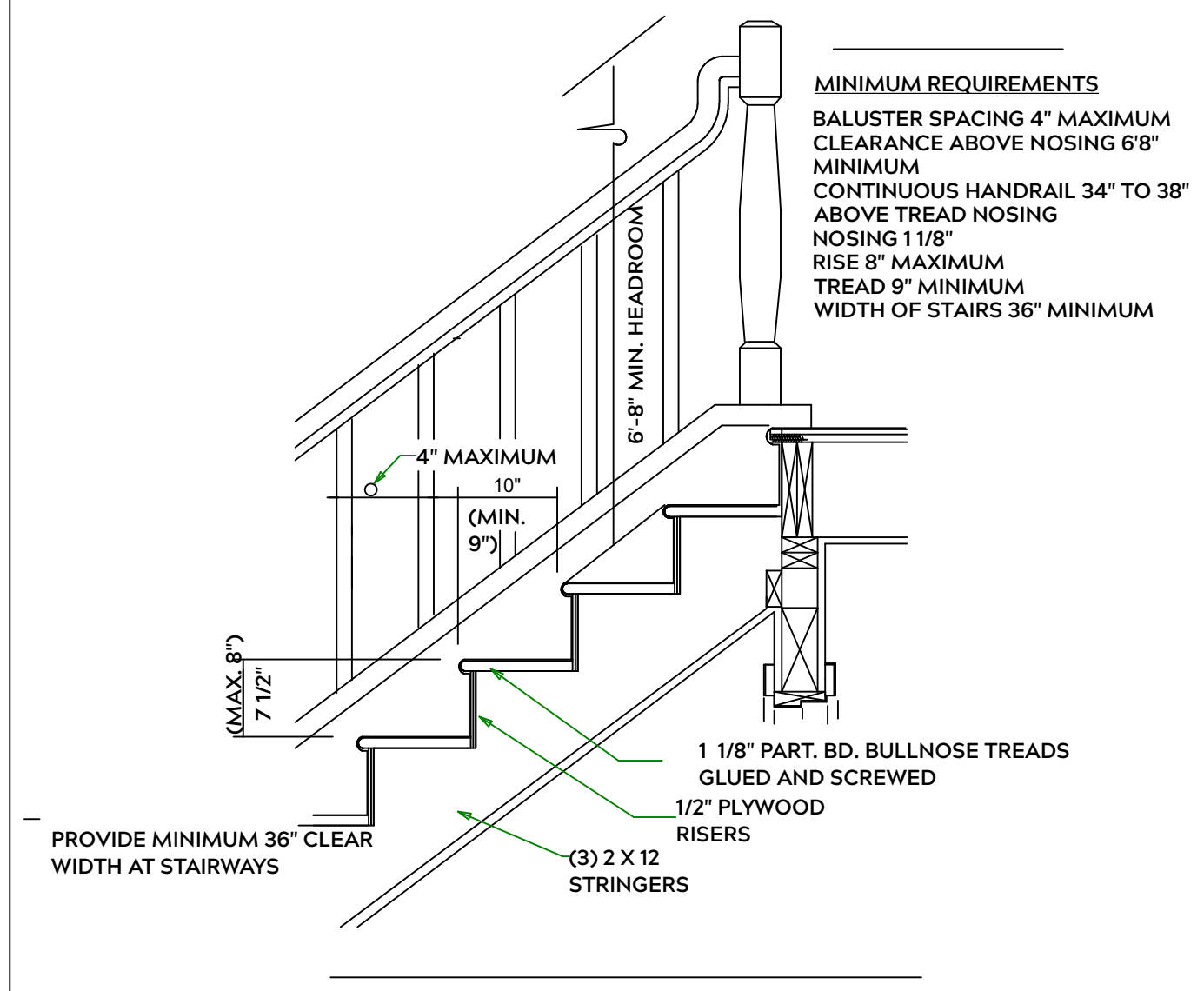

STAIR DETAIL

SHEET TITLE:
DETAIL SHEETS

PROJECT ADDRESS:
Magnolia Hills Lot 61

DESIGNED BY:
Precision Custom Homes
Rae ford, NC
Shaun@PrecisionCustomHomesNC.com

DATE:

1/2/25

SCALE:

1/4" = 1'

SHEET:

A-3

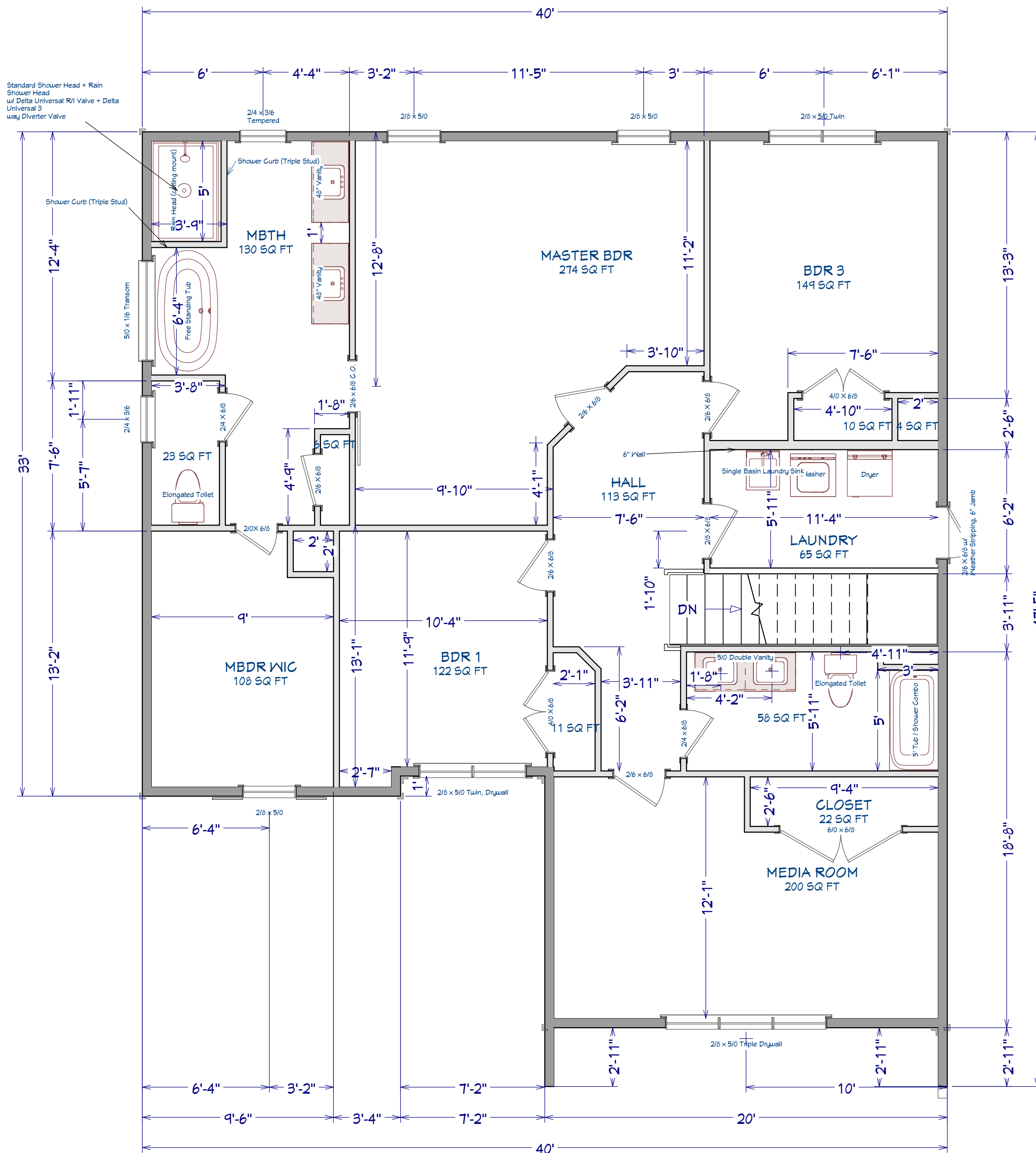

AREA SCHEDULE NAME	AREA
1st FLOOR AREA	1,522 SF
2nd FLOOR AREA	1,492 SF
GARAGE	736 SF
FRONT PORCH	110 SF
BACK PORCH	120 SF
TOTAL HEATED	3,014 SF
TOTAL UNDER ROOF	3,980 SF

SHEET TITLE:
2nd FLOOR

PROJECT ADDRESS:
Magnolia Hills Lot 61

DESIGNED BY:
Precision Custom Homes
RaeFord, NC
Shaun@PrecisionCustomHomesNC.com

DATE:
1/2/25

SCALE:
1/4" = 1'

SHEET:
A-5