

FIONA #2

FOR: SERENITY BUILT HOMES

PERMIT:

DATE: 02-02-22

REVISED:

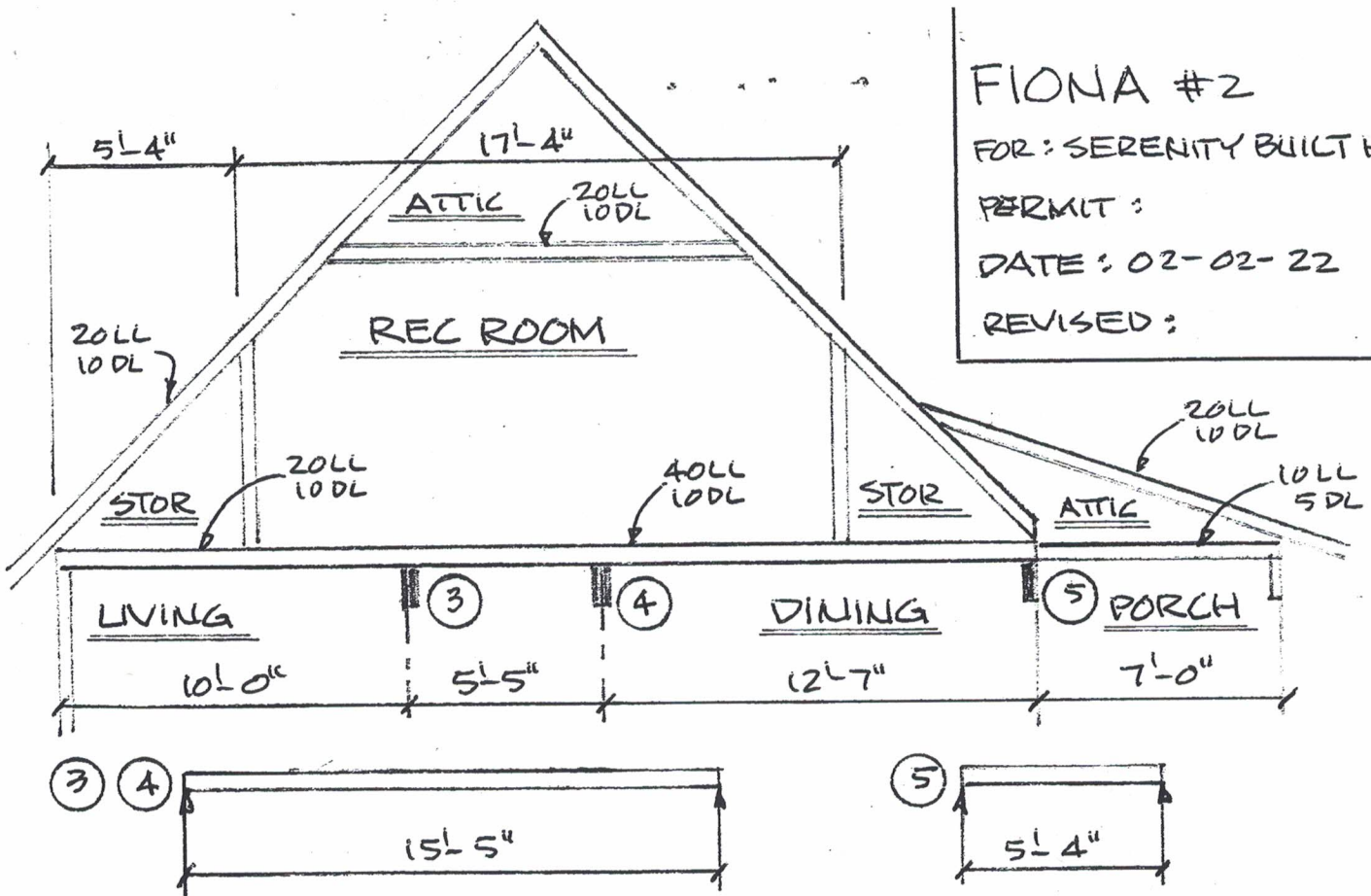

$$\textcircled{3} w = \begin{matrix} \text{[STOR]} \\ (2'-8") \end{matrix} (30 \text{ PSF}) + \begin{matrix} \text{[REC FLOOR]} \\ (5'-1") \end{matrix} (50 \text{ PSF})$$

$$w = 334 \text{ PLF}$$

Choose (3) 1 3/4" x 9 1/4" LVL (see attached)

$$\textcircled{4} w = \begin{matrix} \text{[STOR]} \\ (2'-8") \end{matrix} (30 \text{ PSF}) + \begin{matrix} \text{[REC FLOOR]} \\ (6'-4") \end{matrix} (50 \text{ PSF})$$

$$w = 397 \text{ PLF}$$

Choose (3) 1 3/4" x 11 1/4" LVL (see attached)

$$\textcircled{5} w = \begin{matrix} \text{[ROOF]} \\ (17'-6") \end{matrix} (30 \text{ PSF}) + \begin{matrix} \text{[REC CEIL]} \\ (8'-8") \end{matrix} (30 \text{ PSF}) + \begin{matrix} \text{[REC FLOOR]} \\ (3'-8") \end{matrix} (50 \text{ PSF}) + \begin{matrix} \text{[STOR]} \\ (2'-8") \end{matrix} (30 \text{ PSF}) + \begin{matrix} \text{[PORCH CEIL]} \\ (3'-6") \end{matrix} (15 \text{ PSF})$$

$$w = 1100 \text{ PLF}$$

Choose (2) 1 3/4" x 9 1/4" LVL (see attached)

GANG LAM LVL BY LOUISIANA PACIFIC Z950 FB-2.0E

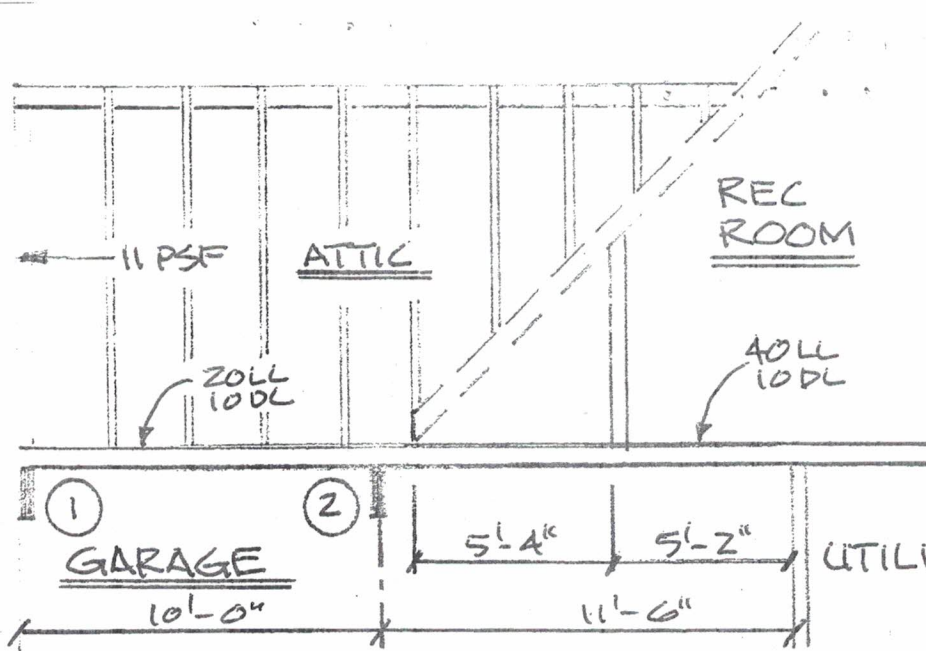

FIONA # 2
 FOR: SERENITY BUILT HOME
 PERMIT:
 DATE: 02-02-22
 REVISED:

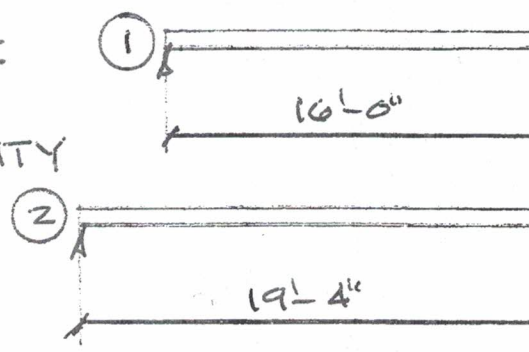

[FLOOR] [GABLE WALL]

① $w = (5'-0") (30 \text{ PSF}) + (8'-0") (11 \text{ PSF})$
 $w = 238 \text{ PLF}$
 Choose (2) $1\frac{3}{4}" \times 11\frac{1}{4}" \text{ LVL (see attached)}$

[ATTIC FLOOR]

② $w = (8'-2") (30 \text{ PSF}) + (2'-7") (50 \text{ PSF})$
 $w = 374 \text{ PLF}$
 Choose (2) $1\frac{3}{4}" \times 16" \text{ LVL (see attached)}$

GANG LAM LVL BY LOUISIANA PACIFIC 2950 FB-2.0E

GANG-LAM LVL 2950 Fb 2.0E MAXIMUM UNIFORM LOAD (PLF)

ALLOWABLE FLOOR LOADS (PLF) 100%

Beam Span (ft)	1 Ply 1 3/4 x 7 1/4			1 Ply 1 3/4 x 9 1/4			1 Ply 1 3/4 x 9 1/2			1 Ply 1 3/4 x 11 1/4			1 Ply 1 3/4 x 11 3/8			1 Ply 1 3/4 x 14			1 Ply 1 3/4 x 16 * Refer To Note 4			1 Ply 1 3/4 x 18 * Refer To Note 4		
	Live Load Deflection		Total Load	Live Load Deflection		Total Load	Live Load Deflection		Total Load	Live Load Deflection		Total Load	Live Load Deflection		Total Load	Live Load Deflection		Total Load	Live Load Deflection		Total Load	Live Load Deflection		Total Load
	L/360	L/480	L/240	L/360	L/480	L/240	L/360	L/480	L/240	L/360	L/480	L/240	L/360	L/480	L/240	L/360	L/480	L/240	L/360	L/480	L/240	L/360	L/480	L/240
	6	681	522	777	1046	1016	1046	1082	1082	1082	1348	1348	1348	1450	1450	1450	1827	1827	1827	2233	2233	2233	2698	2698
7	443	337	639	864	669	864	893	720	893	1102	1102	1102	1181	1181	1181	1470	1470	1470	1772	1772	1772	2110	2110	2110
8	303	229	441	603	461	736	649	497	760	932	794	932	996	918	996	1229	1229	1229	1469	1469	1469	1732	1732	1732
9	215	163	315	434	330	607	467	356	637	748	574	807	861	667	861	1056	1041	1056	1254	1254	1254	1468	1468	1468
10	158	120	231	321	244	467	347	263	504	559	427	704	649	497	758	925	784	925	1094	1094	1094	1274	1274	1274
11	120	90	174	244	185	355	263	199	384	428	325	584	498	380	644	785	603	823	969	870	1094	1274	1274	1274
12	93	70	134	189	143	276	205	155	298	334	253	484	389	296	543	618	473	732	870	686	870	1007	945	1007
13	73	55	105	150	113	218	162	122	235	265	201	385	310	235	449	495	377	625	717	550	790	911	761	911
14	59	44	84	121	91	175	130	96	189	214	162	310	250	189	363	401	305	541	584	446	689	807	621	832
15	48	36	68	98	74	142	106	80	154	175	132	253	205	155	297	329	250	472	481	367	601	668	512	744
16	40	-	55	81	61	117	88	66	126	145	109	209	170	128	245	274	207	396	401	305	529	559	427	656
17	33	-	46	68	51	97	74	55	105	121	91	174	142	107	205	230	174	332	337	256	469	472	359	582
18	-	-	38	58	43	81	62	47	88	102	77	147	120	91	172	194	147	281	286	217	413	401	305	520
19	-	-	32	49	37	68	53	40	74	87	66	124	102	77	146	166	125	239	245	185	353	344	261	467
20	-	-	-	42	32	58	46	34	63	75	57	106	88	66	125	143	108	205	211	160	304	297	225	421
21	-	-	-	37	-	50	39	-	54	65	49	91	76	57	108	124	93	177	183	138	263	258	195	371
22	-	-	-	32	-	43	34	-	47	57	43	79	66	50	93	108	81	154	160	121	229	225	170	324
23	-	-	-	-	-	37	-	-	40	50	37	68	58	44	81	95	71	134	140	106	200	198	150	284
24	-	-	-	-	-	32	-	-	35	44	33	60	51	39	71	84	63	117	124	93	176	175	132	250
25	-	-	-	-	-	-	-	-	-	39	-	52	46	34	62	74	56	103	110	83	155	155	117	221
26	-	-	-	-	-	-	-	-	-	35	-	46	41	31	55	66	50	91	98	74	138	138	104	196
27	-	-	-	-	-	-	-	-	-	31	-	41	36	-	48	59	45	81	88	66	122	124	93	175
28	-	-	-	-	-	-	-	-	-	-	-	36	33	-	43	53	40	72	79	59	109	111	84	156
29	-	-	-	-	-	-	-	-	-	-	-	32	-	-	38	48	36	64	71	53	98	100	76	140
30	-	-	-	-	-	-	-	-	-	-	-	-	-	-	34	43	33	57	64	48	88	91	68	126

How to use maximum uniform load tables:

- Select the correct table for the beam application you need.
- Choose the required beam span in the left column.
- Select a beam depth from the tables that satisfies BOTH the live and total load PLF on the beam.
- Check the bearing requirements as shown on page 8.

Example: Floor live load 480 PLF, L/360 deflection limit.
Floor total load 660 PLF, L/240 deflection limit.
Beam span 14' - 0"

Solution: Try 2 plies 1 3/4" x 11 3/8", which can carry:
• Live load 2 x 250 = 500 > 480 PLF ✓OK
• Total load 2 x 363 = 726 > 660 PLF ✓OK

Notes (for page 6 and 7)

- Beam spans are defined as follows: Simple span dimensions are measured from inside face of supports. Multiple span dimensions are measured from inside face of exterior supports to center line of interior supports.
- These tables are for simple spans (with a support at each end) or for continuous (multiple span) beams if spans are equal.
- PLF values are for a single ply of 1 3/4" Gang-Lam LVL.
 - Double the values for two plies or 3 1/2" thickness.
 - Triple the values for three plies or 5 1/4" thickness.
- For 1 3/4" x 16" beams and deeper, two plies (minimum) are required.
- More than three plies may require special design. Contact your L-P engineered products distributor.

CONNECTION OF MULTIPLE PLY BEAMS

10A TOP LOADED (3 PLYS MAXIMUM)

Framing is applied on top of the beam so that each ply carries an equal load.

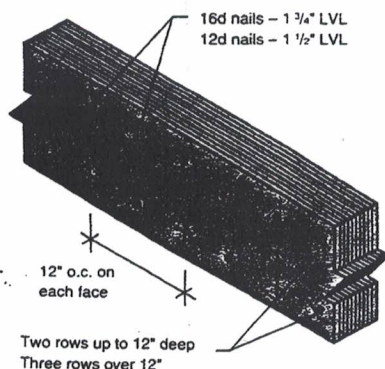

10B TOP LOADED 4 PLYS

Framing is applied on top of the beam so that each ply carries an equal load.

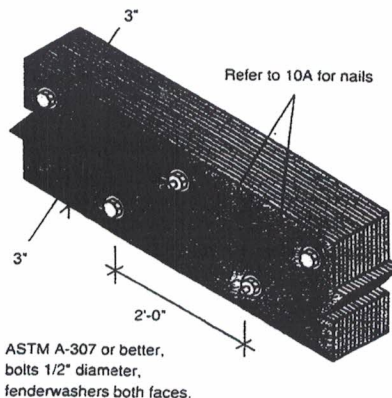

10C SIDE LOADED

The same framing is used on each side of the beam so the same load is carried on each face.

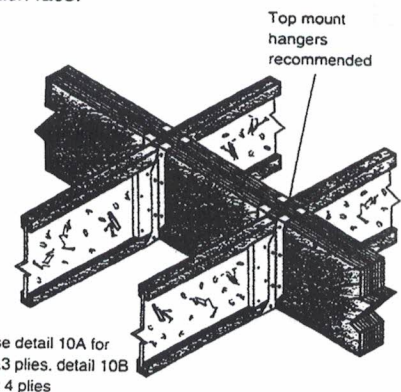

GANG-LAM LVL 2950 Fb 2.0E MAXIMUM UNIFORM LOAD (PLF)

ALLOWABLE FLOOR LOADS (PLF) 100%

Beam Span (ft)	1 Ply 1 1/4 x 7 1/4			1 Ply 1 1/4 x 9 1/4			1 Ply 1 1/4 x 9 1/2			1 Ply 1 1/4 x 11 1/4			1 Ply 1 1/4 x 11 3/8			1 Ply 1 1/4 x 14			1 Ply 1 1/4 x 16 * Refer To Note 4			1 Ply 1 1/4 x 18 * Refer To Note 4		
	Live Load Deflection		Total Load	Live Load Deflection		Total Load	Live Load Deflection		Total Load	Live Load Deflection		Total Load	Live Load Deflection		Total Load	Live Load Deflection		Total Load	Live Load Deflection		Total Load	Live Load Deflection		Total Load
	L/360	L/480	L/240	L/360	L/480	L/240	L/360	L/480	L/240	L/360	L/480	L/240	L/360	L/480	L/240	L/360	L/480	L/240	L/360	L/480	L/240	L/360	L/480	L/240
6	681	522	777	1046	1016	1046	1082	1082	1082	1348	1348	1348	1450	1450	1450	1827	1827	1827	2233	2233	2233	2698	2698	2698
7	443	337	639	864	669	864	893	720	893	1102	1102	1102	1181	1181	1181	1470	1470	1470	1772	1772	1772	2110	2110	2110
8	303	229	441	603	461	736	649	497	760	932	794	932	996	918	996	1229	1229	1229	1469	1469	1469	1732	1732	1732
9	215	163	315	434	330	607	467	356	637	748	574	807	861	667	861	1056	1041	1056	1254	1254	1254	1468	1468	1468
10	158	120	231	321	244	467	347	263	504	559	427	704	649	497	758	925	784	925	1094	1094	1094	1274	1274	1274
11	120	90	174	244	185	355	263	199	384	428	325	584	498	380	644	785	603	823	969	870	969	1125	1125	1125
12	93	70	134	189	143	276	205	155	298	334	253	484	389	296	543	618	473	732	870	686	870	1007	945	1007
13	73	55	105	150	113	218	162	122	235	265	201	385	310	235	449	495	377	625	717	550	790	911	761	911
14	59	44	84	121	91	175	130	96	189	214	162	310	250	189	363	401	305	541	584	446	689	807	621	832
15	48	36	68	98	74	142	106	80	154	175	132	253	205	155	297	329	250	472	481	367	601	668	512	744
16	40	-	55	81	61	117	88	66	126	145	109	209	170	128	245	274	207	396	401	305	529	559	427	656
17	33	-	46	68	51	97	74	55	105	121	91	174	142	107	205	230	174	332	337	256	469	472	359	582
18	-	-	38	58	43	81	62	47	88	102	77	147	120	91	172	194	147	281	286	217	413	401	305	520
19	-	-	32	49	37	68	53	40	74	87	66	124	102	77	146	166	125	239	245	185	353	344	261	467
20	-	-	-	42	32	58	46	34	63	75	57	106	88	66	125	143	108	205	211	160	304	297	225	421
21	-	-	-	37	-	50	39	-	54	65	49	91	76	57	108	124	93	177	183	138	263	258	195	371
22	-	-	-	32	-	43	34	-	47	57	43	79	66	50	93	108	81	154	160	121	229	225	170	324
23	-	-	-	-	-	37	-	-	40	50	37	68	58	44	81	95	71	134	140	106	200	198	150	284
24	-	-	-	-	-	32	-	-	35	44	33	60	51	39	71	84	63	117	124	93	176	175	132	250
25	-	-	-	-	-	-	-	-	39	-	52	46	34	62	74	56	103	110	83	155	155	117	221	
26	-	-	-	-	-	-	-	-	35	-	46	41	31	55	66	50	91	98	74	138	138	104	196	
27	-	-	-	-	-	-	-	-	31	-	41	36	-	48	59	45	81	88	66	122	124	93	175	
28	-	-	-	-	-	-	-	-	-	-	36	33	-	43	53	40	72	79	59	109	111	84	156	
29	-	-	-	-	-	-	-	-	-	-	32	-	-	38	48	36	64	71	53	98	100	76	140	
30	-	-	-	-	-	-	-	-	-	-	-	-	-	34	43	33	57	64	48	88	91	68	126	

How to use maximum uniform load tables:

- Select the correct table for the beam application you need.
- Choose the required beam span in the left column.
- Select a beam depth from the tables that satisfies BOTH the live and total load PLF on the beam.
- Check the bearing requirements as shown on page 8.

Example: Floor live load 480 PLF, L/360 deflection limit.
 Floor total load 660 PLF, L/240 deflection limit.
 Beam span 14' - 0"

Solution: Try 2 plies 1 1/4" x 11 3/8", which can carry:

- Live load $2 \times 250 = 500 > 480$ PLF ✓OK
- Total load $2 \times 363 = 726 > 660$ PLF ✓OK

Notes (for page 6 and 7)

- Beam spans are defined as follows: Simple span dimensions are measured from inside face of supports. Multiple span dimensions are measured from inside face of exterior supports to center line of interior supports.
- These tables are for simple spans (with a support at each end) or for continuous (multiple span) beams if spans are equal.
- PLF values are for a single ply of 1 1/4" Gang-Lam LVL.
 - Double the values for two plies or 3 1/2" thickness.
 - Triple the values for three plies or 5 1/4" thickness.
- * For 1 1/4" x 16" beams and deeper, two plies (minimum) are required.
- More than three plies may require special design. Contact your L-P engineered products distributor.

CONNECTION OF MULTIPLE PLY BEAMS

10 TOP LOADED (3 PLYS MAXIMUM)

Framing is applied on top of the beam so that each ply carries an equal load.

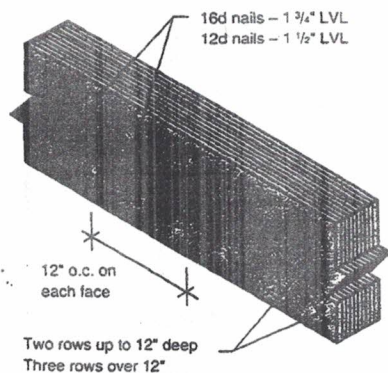

10 TOP LOADED 4 PLYS

Framing is applied on top of the beam so that each ply carries an equal load.

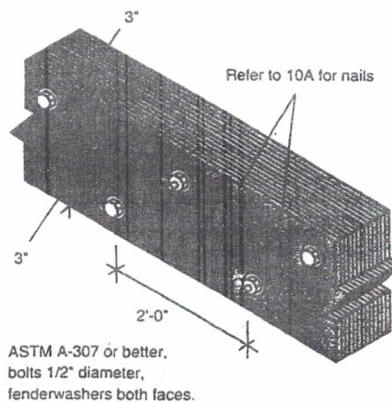

100 SIDE LOADED

The same framing is used on each side of the beam so the same load is carried on each face.

