

TELFAIR

BRIARWOOD BLUFF
LOT 0006



PLAN ID 050620

110 VILLAGE TRAIL SUITE 215
WOODSTOCK, GA. 30188

DRAWING INDEX	
A0.0	COVER SHEET
A1.1	FRONT ELEVATIONS
A2.1	SIDE & REAR ELEVATIONS
A3.1	SLAB FOUNDATIONS
A5.1	FIRST FLOOR PLAN
A5.2	SECOND FLOOR
A6.1	ROOF PLANS
A7.2-A7.3	ELECTRICAL PLANS

AREA TABULATION	
FIRST FLOOR	1803
SECOND FLOOR	570
TOTAL	2373
GARAGE	403
FRONT PORCH ELEVATION A D G (COVERED)	24
REAR PATIO	120

PLAN REVISIONS			
DATE	BY	REVISION	PAGE #
7/19/2019	AW	Added elevations K & L	A1.11-A1.12
7/25/2019	AW	Relocated water heater to increase sq. ft. from 1795 to 1803	A3.1, A5.1, A7.2, A7.2.1, A8.1
8/29/2019	AW	PROTOTYPE WALK CHANGES - SEE REVISION SHEET	ALL
11/18/2019	AW	For 2-story version made wall between stairs and Owner's 2x6 and coat closet wall 2x6	A5.1.1
11/18/2019	AW	Flipped location of HVAC platform for 2-story version to rear of house which relocated B-5 W.I.C. and window	A5.3.2, A6.1-A6.3, A7.3.2
2/12/2020	AW	Added note for LVL at rear 3050 twin for plans without 2nd floor per truss/engineering	A5.1
5/1/2020	AW	PCR #3744 Changed hall bath 3068 door to 2868 to clear cabinet knobs	A5.1
5/6/2020	AW	PCR #3777 Removed small piece of foyer chair rail/shadow box between living rm opng & kitchen	A8.1
8/11/2020	AW	Elevations K & L - changed front porch cedar columns to std. box column and removed decorative brackets on front porch of Elev L and added 1x10 at fin. flr. level where B&B shown	A1.11, A1.12
11/1/2021	AW	PCR #4579 Adjust location of opt. pendants & opt. LED Kitchen lights for better placement	A7.3

GOVERNMENTAL CODES & STANDARDS
HOME TO BE BUILT TO CONFORM TO ALL APPLICABLE LOCAL CODES, PRACTICES AND STANDARDS
BUILDING CODE ANALYSIS / DESIGN CRITERIA
HOME TO BE BUILT TO MEET OR EXCEED ALL LOCAL CODES AND DESIGN CRITERIA

BRIARWOOD BLUFF LOT 0006

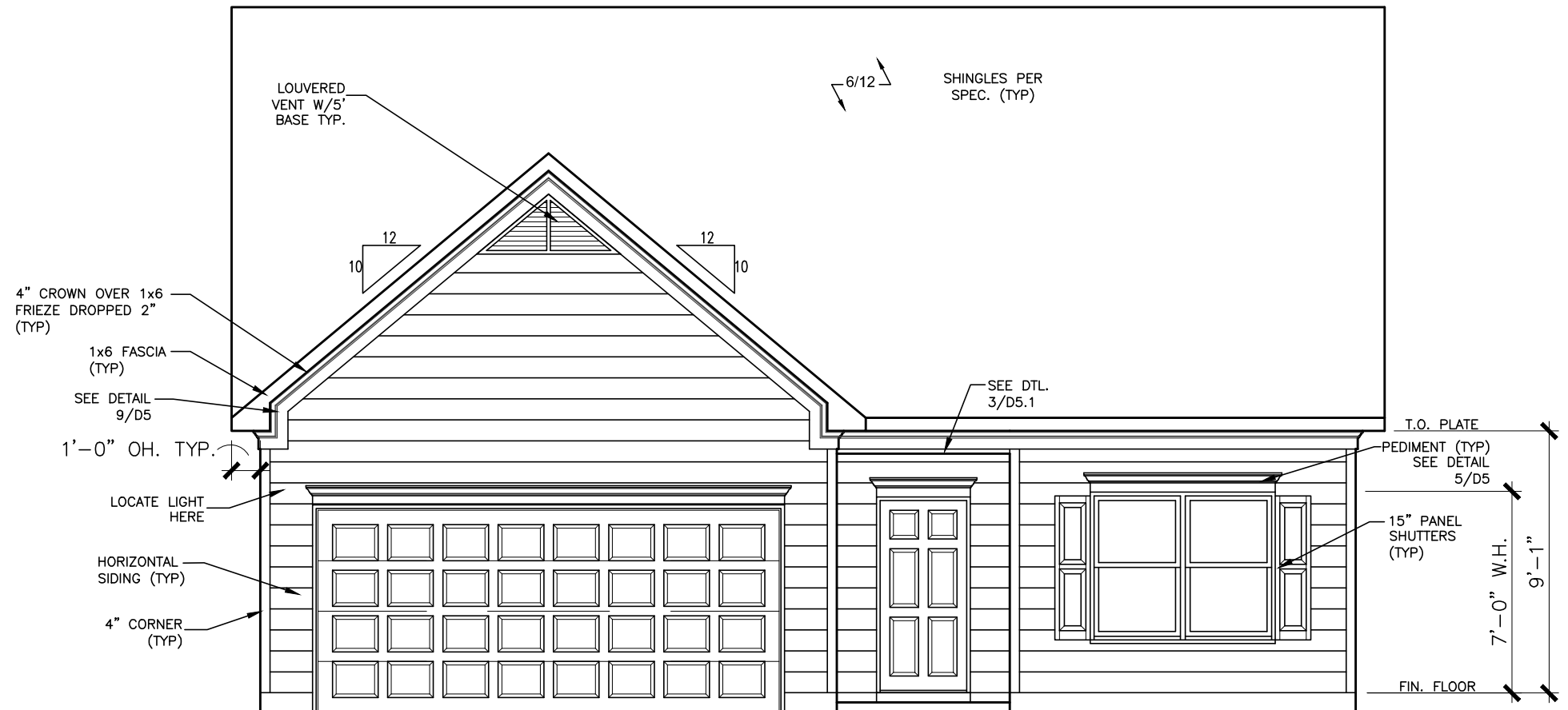

FRONT ELEVATION "A"

SCALE : 3/16" = 1'-0"

ALL NON-MASONRY RETURNS TO
BE HORIZONTAL SIDING

SEE SHEET D3 OF SDH TYPICAL
DETAILS FOR SOFFIT DETAILS PER
SOFFIT MATERIAL

DATE	REVISION	BY
#	#	#
#	#	#
#	#	#
#	#	#
#	#	#



ELEVATIONS
FRONT ELEVATION
TELFAIR

SMITH DOUGLAS HOMES
110 VILLAGE TRAIL
SUITE 115
WOODSTOCK, GA 30188
www.smithdouglas.com

SMITH DOUGLAS HOMES
expressly reserves its
property rights in these
plans and drawings.
These plans and related
drawings are not to be
reproduced without written
consent from SMITH
DOUGLAS HOMES.

BY: TJJ	CH: AW
DATE: 10/14/2024	
FACADE OPT: A	
PLAN ID:	
FND: ALL	ELEV: A
PAGE NO: A1.1	

BRIARWOOD BLUFF LOT 0006

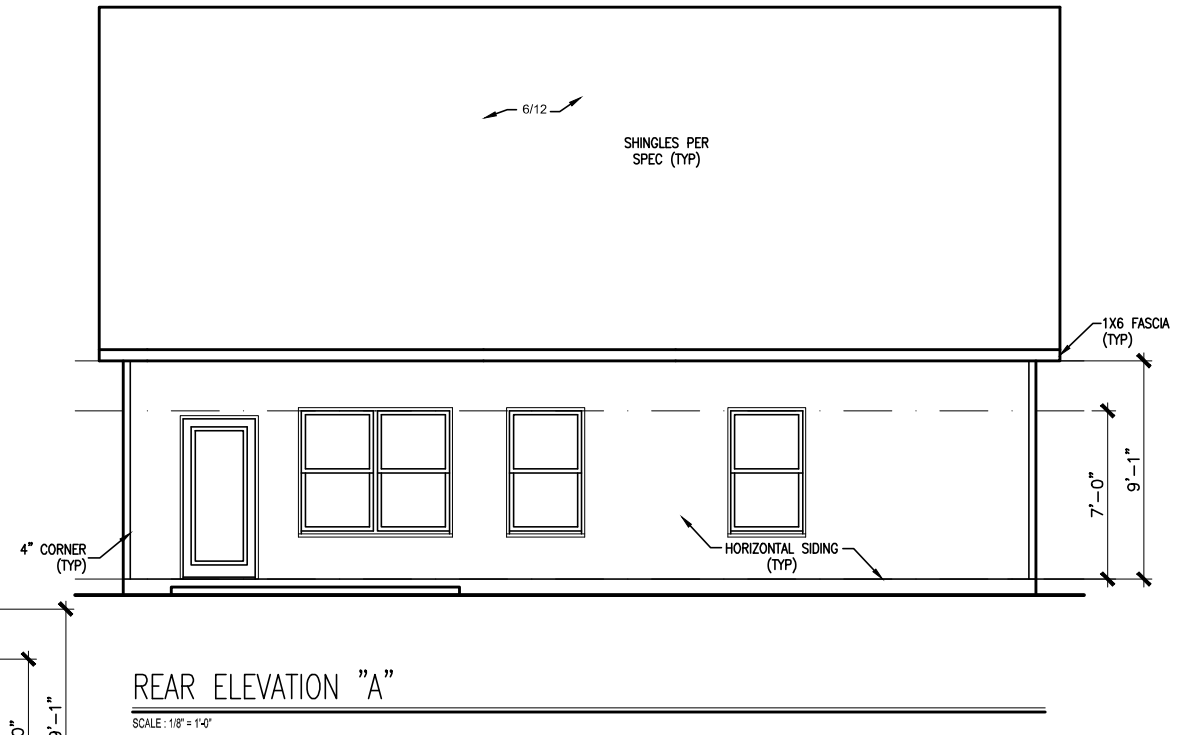
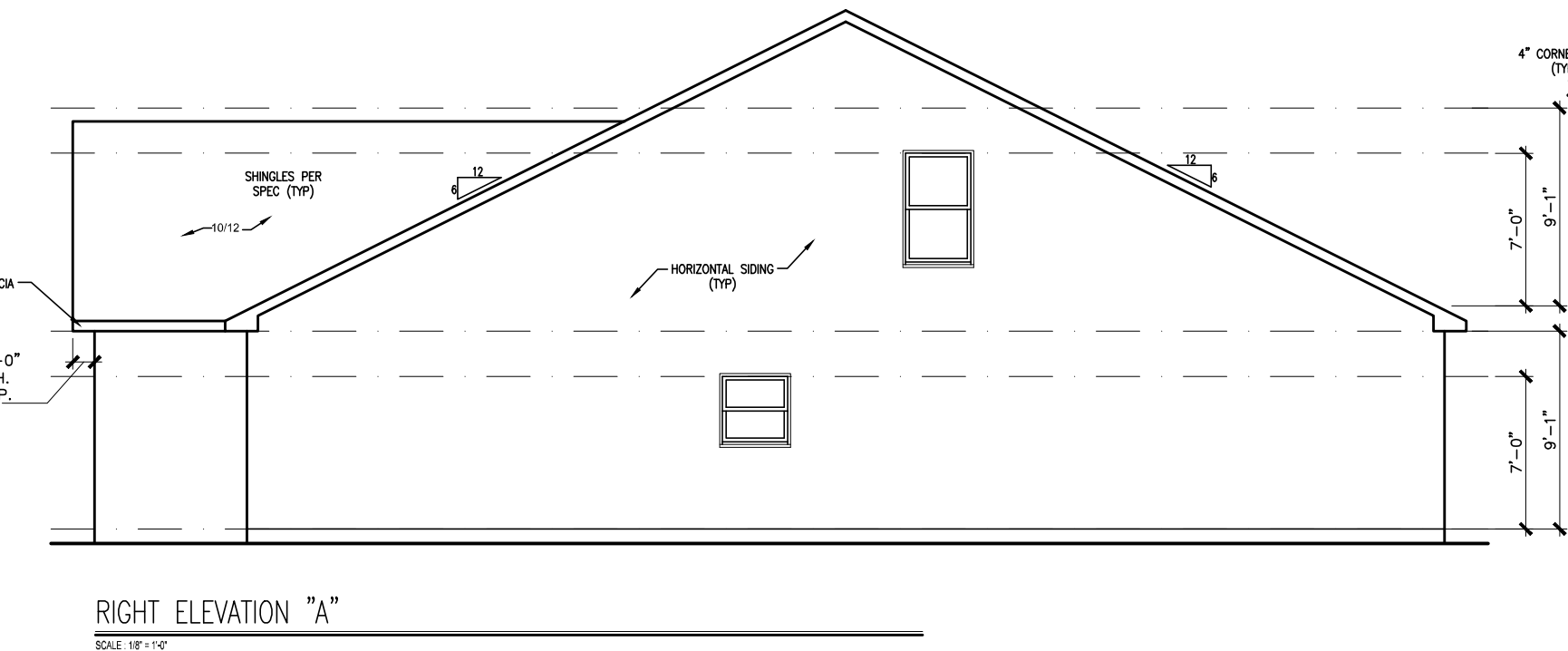
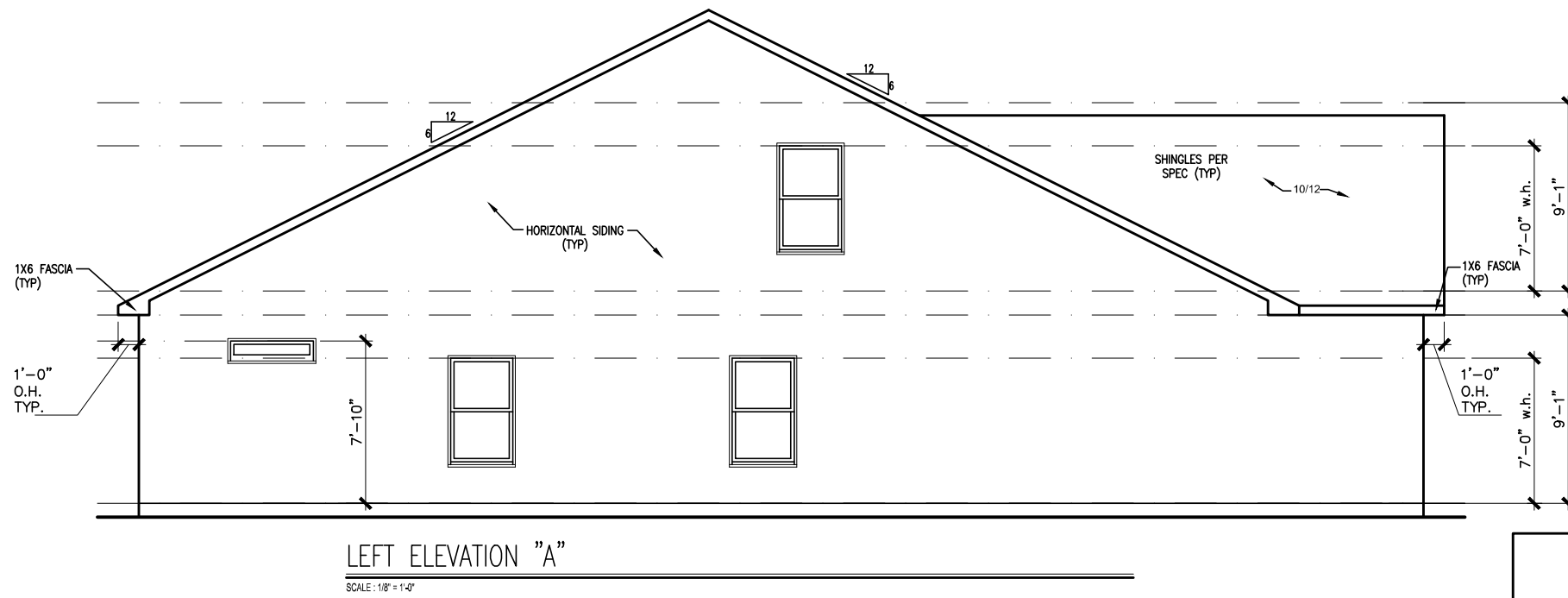

DATE	REVISION	BY



ELEVATIONS
SIDES AND REAR
TELFAIR

SMITH DOUGLAS HOMES
110 VILLAGE TRAIL
SUITE 115
WOODSTOCK, GA 30188
www.smithdouglas.com

SMITH DOUGLAS HOMES expressly reserves its property rights in these plans and drawings. These plans and related drawings are not to be reproduced without written consent from SMITH DOUGLAS HOMES.

BY: TJJ	CH: AW
DATE: 10/14/2024	
FACADE OPT: A	
PLAN ID:	
PND: ALL	ELEV: A
PAGE NO: A2.1	

BRIARWOOD BLUFF LOT 0006

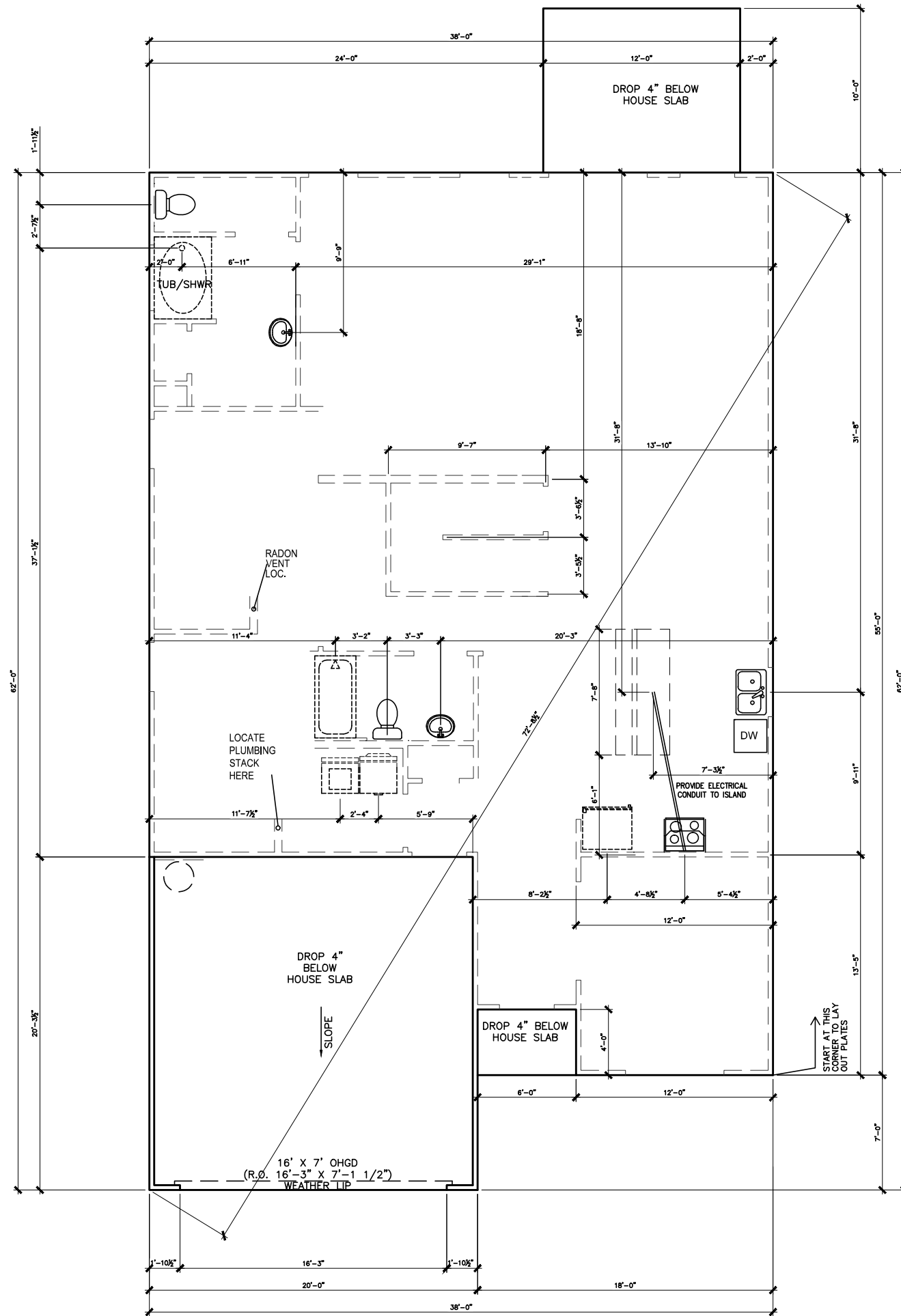

*RADON VENT
PROVIDED PER
LOCAL CODE

REFER TO DETAIL 3/D1 FOR
BRICK LEDGE DETAIL WHEN
BRICK VENEER IS CHOSEN

SLAB PLAN OPTIONAL SECOND FLOOR

BY	REVISION	DATE
#	#	#
#	#	#
#	#	#
#	#	#
#	#	#
#	#	#



FOUNDATION PLAN
SLAB PLAN
TELFAIR

SMITH DOUGLAS HOMES
110 VILLAGE TRAIL
SUITE 115
WOODSTOCK, GA 30188
www.smithdouglashomes.com

SMITH DOUGLAS HOMES
expressly reserves its
property rights in these
plans and drawings.
These plans and related
drawings are not to be
reproduced without written
consent from SMITH
DOUGLAS HOMES.

BY: TJJ	CH: AW
DATE: 10/14/2024	
FACADE OPT: A	
PLAN ID:	
FRONT: ALL	ELEV: A
PAGE NO: A3.1	

BRIARWOOD BLUFF LOT 0006

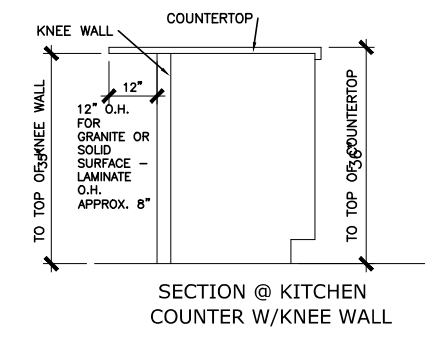
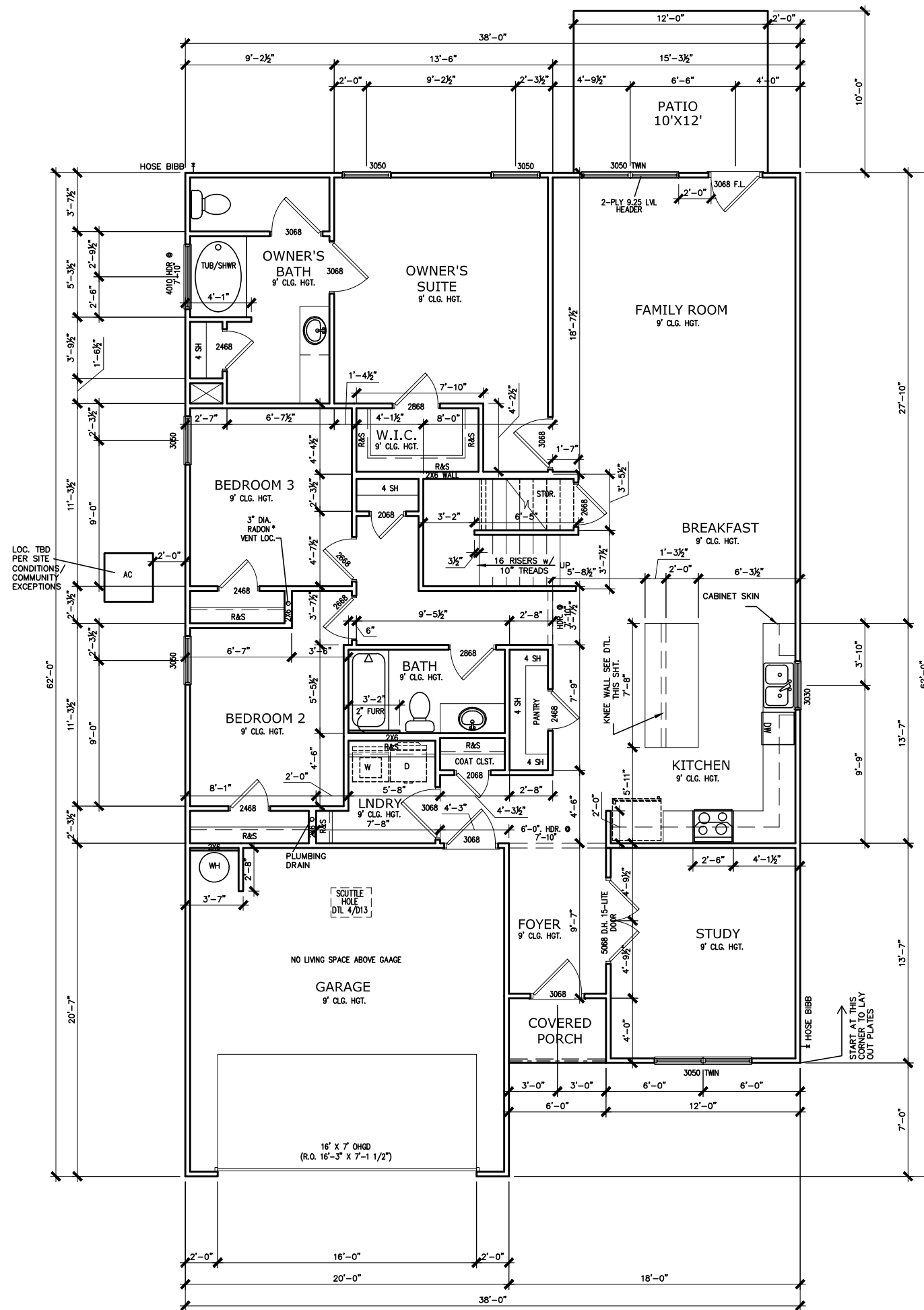

REFER TO MANUFACTURER'S
SPECS. FOR DRAIN LOCATIONS
ON DETAIL SHEETS
D12, D12.1, D12.2 & D12.3

*RADON VENT PROVIDED
PER LOCAL CODE

DATE	REVISION	BY	#

SMITH DOUGLAS HOMES
QUALITY | INTEGRITY | VALUE

FLOOR PLAN
FIRST FLOOR
TELFAIR

SMITH DOUGLAS HOMES
110 VILLAGE TRAIL
SUITE 115
WOODSTOCK, GA 30188
www.smithdouglashomes.com

SMITH DOUGLAS HOMES
expressly reserves its
property rights in these
plans and drawings.
These plans and related
drawings are not to be
reproduced without written
consent from SMITH
DOUGLAS HOMES.

BY: TJJ	CH: AW
DATE: 10/14/2024	
FACADE OPT: A	
PLAN ID:	
FND: ALL	ELEV: A
PAGE NO: A5.1	

FIRST FLOOR PLAN

BRIARWOOD BLUFF LOT 0006

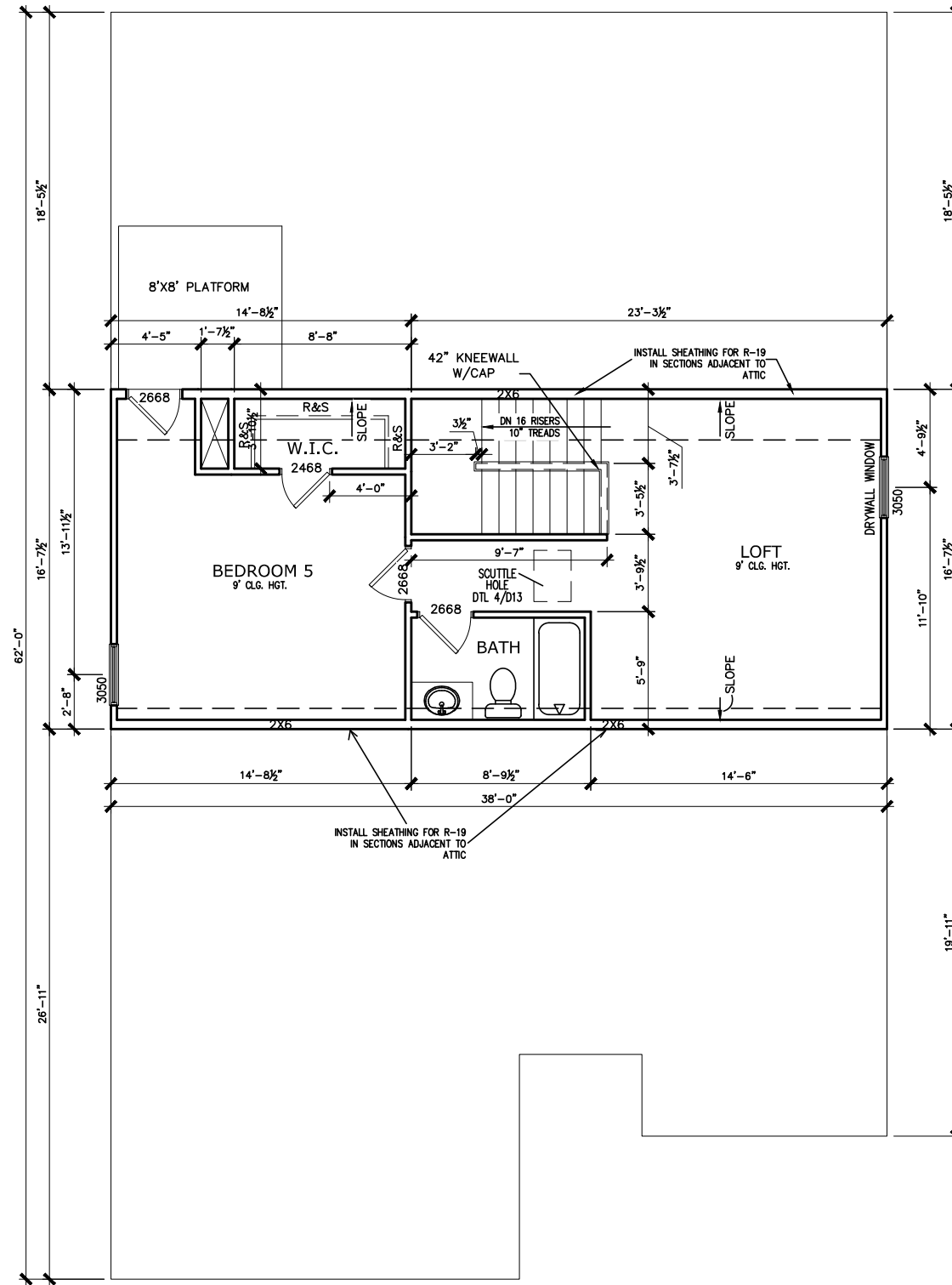

SECOND FLOOR PLAN

SCALE: 1/8" = 1'-0"

DATE	REVISION	BY	#



FLOOR PLAN
SECOND FLOOR
TELFAIR

SMITH DOUGLAS HOMES
110 VILLAGE TRAIL
SUITE 115
WOODSTOCK, GA 30188
www.smithdouglas.com

SMITH DOUGLAS HOMES expressly reserves its property rights in these plans and drawings. These plans and related drawings are not to be reproduced without written consent from SMITH DOUGLAS HOMES.

BY: TJJ	CH: AW
DATE: 10/14/2024	
FACADE OPT: A	
PLAN ID:	
FND: ALL	ELEV: A
PAGE NO: A5.2	

BRIARWOOD BLUFF LOT 0006

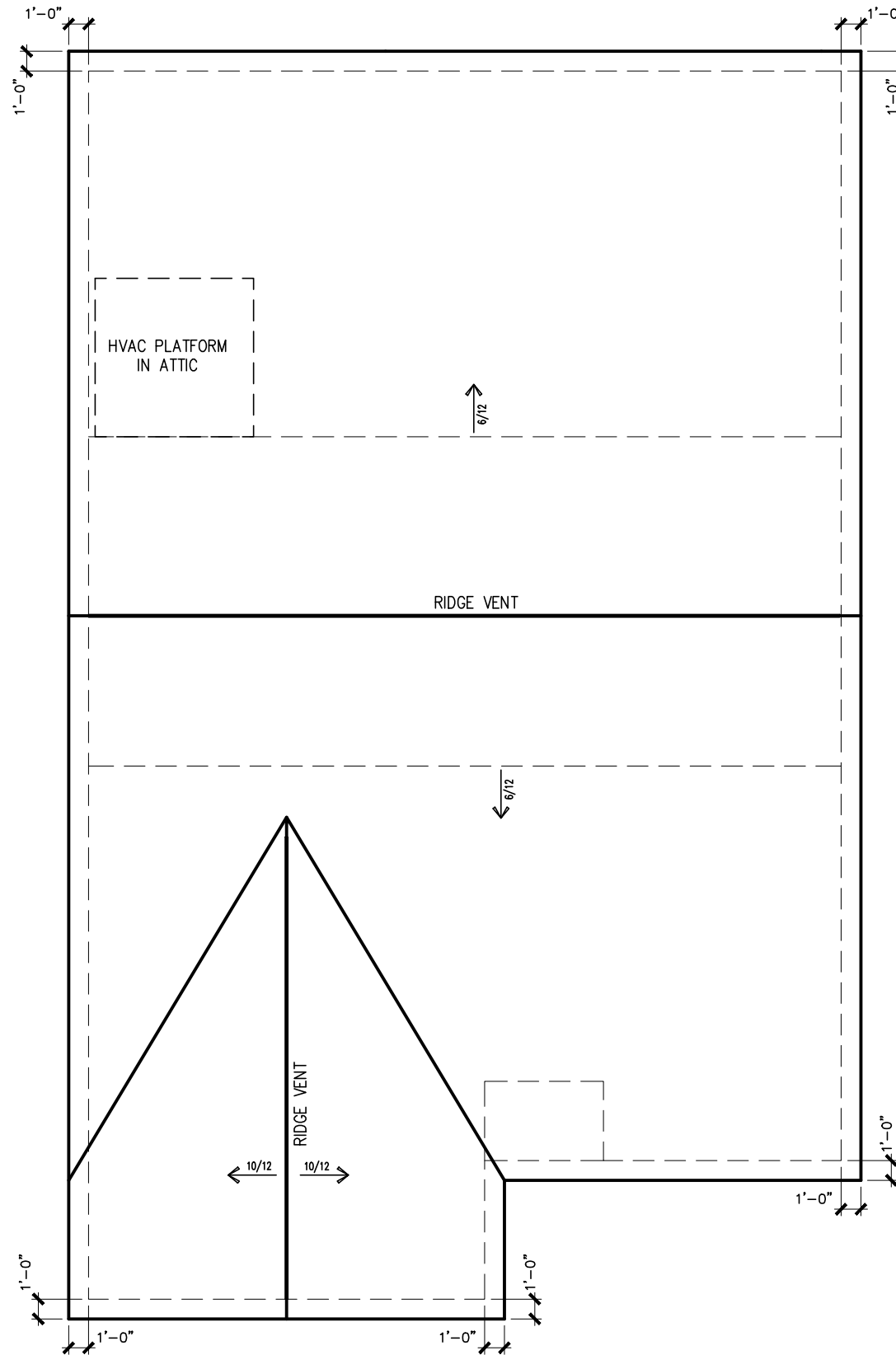

ROOF PLAN "A" W/ 2ND FLOOR

SCALE : 1/8" = 1'-0"

DATE	REVISION	BY
#	#	#
#	#	#
#	#	#
#	#	#
#	#	#



ROOF PLAN
ROOF PLAN
TELFAIR

SMITH DOUGLAS HOMES
110 VILLAGE TRAIL
SUITE 115
WOODSTOCK, GA 30188
www.smithdouglas.com

SMITH DOUGLAS HOMES
expressly reserves its
property rights in these
plans and drawings.
These plans and related
drawings are not to be
reproduced without written
consent from SMITH
DOUGLAS HOMES.

BY: TJJ	CH: AW
DATE: 10/14/2024	
FACADE OPT: A	
PLAN ID:	
FND: ALL	ELEV: A
PAGE NO: A6.1	

BRIARWOOD BLUFF LOT 0006

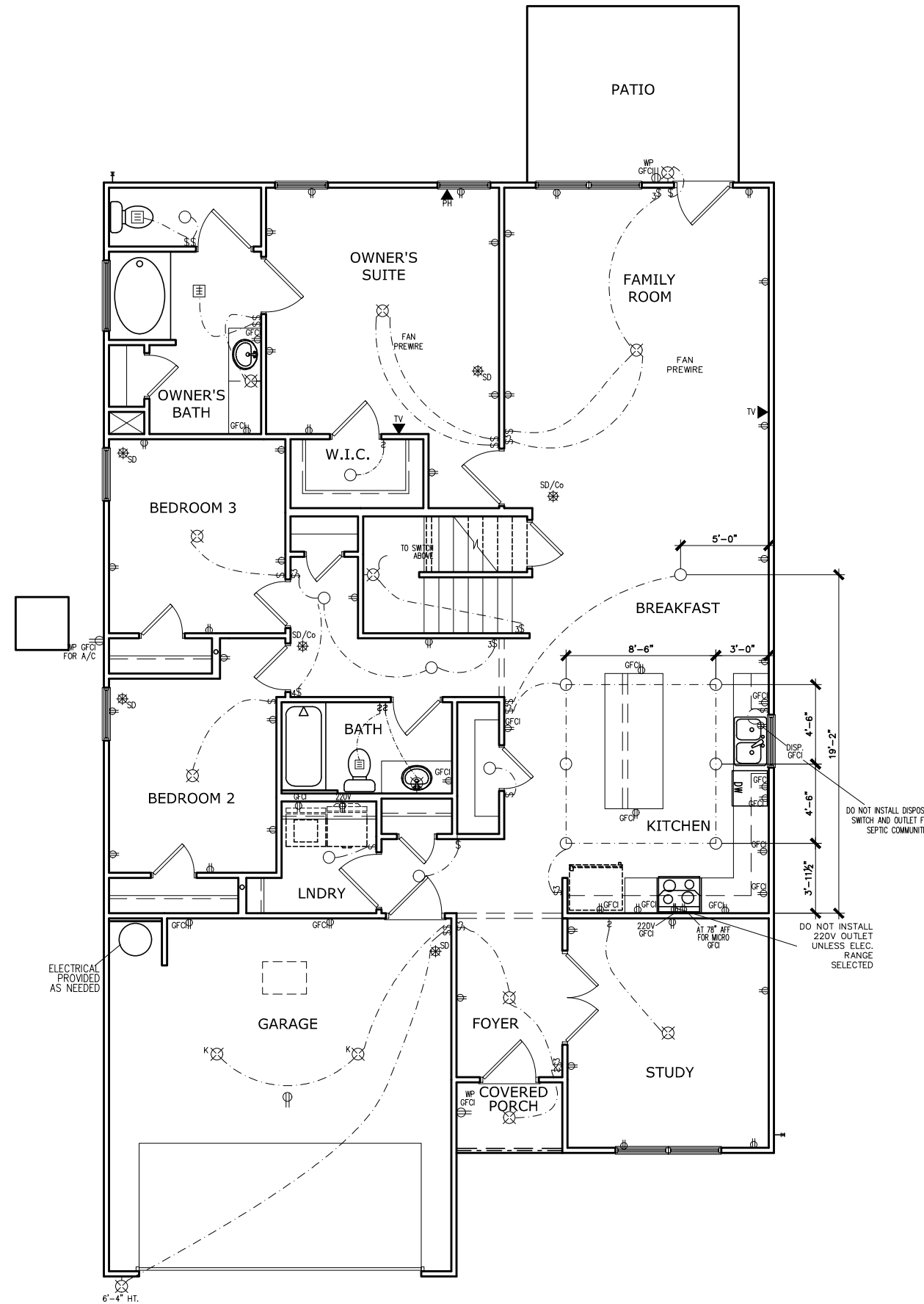

ELECTRICAL LEGEND

\$	SWITCH	TV	TV
\$3	3 WAY SWITCH	⊕	120V RECEPTACLE
\$4	4 WAY SWITCH	⊕	120V SWITCHED RECEPTACLE
⊗	CEILING FIXTURE	⊕	220V RECEPTACLE
⊕	KEYLESS	⊕	GFCI OUTLET
⊗	WALL MOUNT FIXTURE	⊕	ARCH FAULT CIRCUIT INTERRUPTER
○	CEILING FIXTURE	†	GAS LINE
●	FLEX CONDUIT	†	WATER LINE
CH	CHIMES	⊥	HOSE BIBB
PH	TELEPHONE	⊕	FLOOD LIGHT
SD/Co	SMOKE DETECTOR & CARBON MONOXIDE	⊕	1x4 LUMINOUS FIXTURE
SO	SECURITY OUTLET	⊗	CEILING FAN
□	GARAGE DOOR OPENER	—	ELECTRICAL WIRING
⊕	EXHAUST FAN	⊕	CEILING FIXTURE
⊕	FAN/LIGHT		

ELECTRICAL PLANS TO FOLLOW ALL LOCAL CODES

APPROX. FIXTURE HGTS (MEASURED FROM BOTTOM OF FIXTURE)

BREAKFAST/DINING ROOM	63" ABOVE FINISHED FLOOR
KITCHEN PENDANT LIGHTS	33" ABOVE COUNTER TOP
TWO STORY FOYER FIXTURE	96" ABOVE FINISHED FLOOR
CEILING FAN	96" ABOVE FINISHED FLOOR

NOTE: FINAL PLACEMENT OF PHONE/CABLE T.B.D. ON SITE BY THE BUILDER

BY	REVISION	#	#	#	#	#

DATE

SMITH DOUGLAS HOMES
QUALITY | INTEGRITY | VALUE

ELECTRICAL PLAN
FIRST FLOOR
TELFAIR

SMITH DOUGLAS HOMES
110 VILLAGE TRAIL
SUITE 115
WOODSTOCK, GA 30188
www.smithdouglas.com

SMITH DOUGLAS HOMES expressly reserves its property rights in these plans and drawings. These plans and related drawings are not to be reproduced without written consent from SMITH DOUGLAS HOMES.

BY: TJJ	CH: AW
DATE: 10/14/2024	
FACADE OPT: A	
PLAN ID:	
FND: ALL	ELEV: A
PAGE NO: A7.2	

BRIARWOOD BLUFF LOT 0006

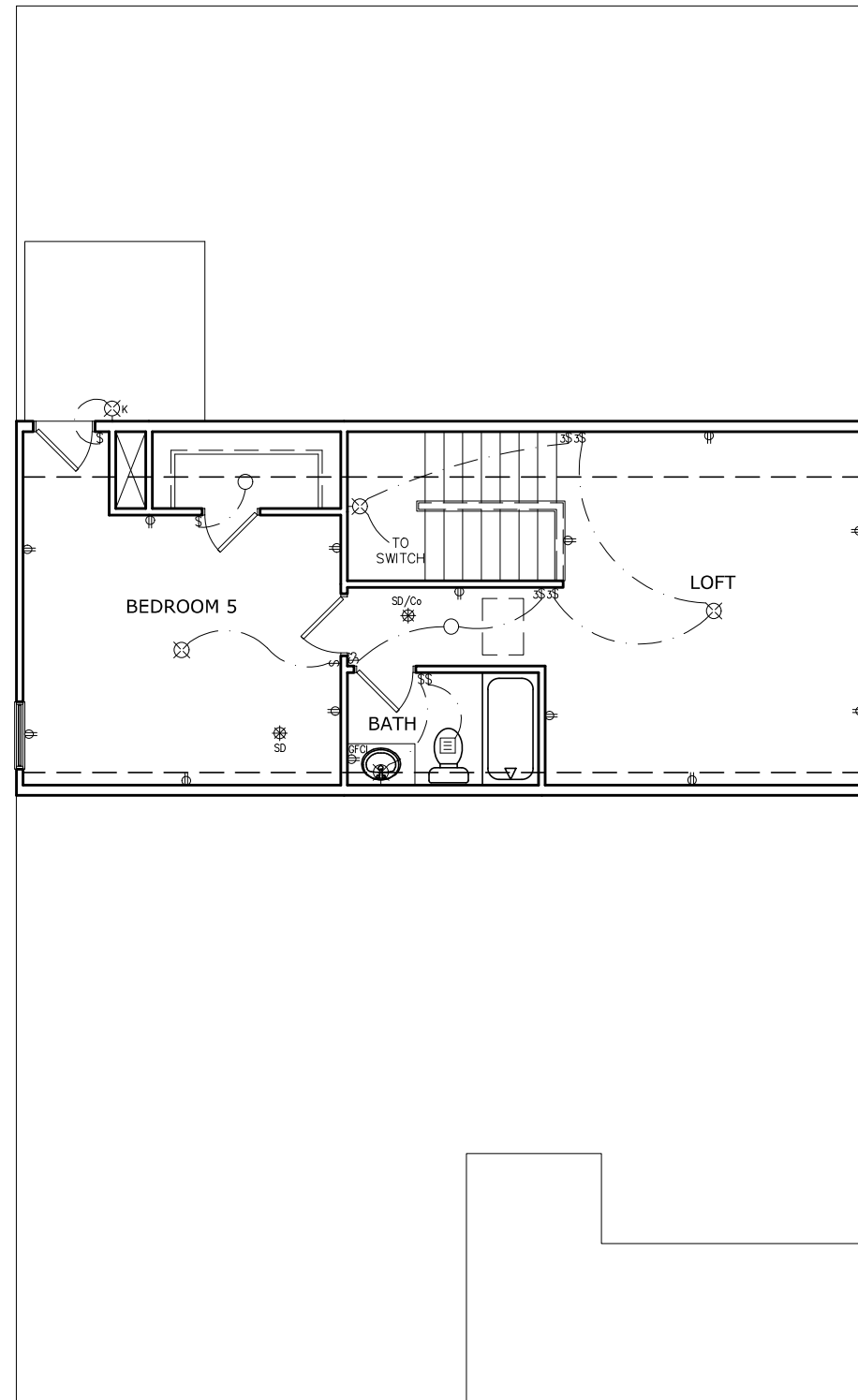

ELECTRICAL LEGEND

\$	SWITCH	TV	TV
\$3	3 WAY SWITCH	⊕	120V RECEPTACLE
\$4	4 WAY SWITCH	⊕	120V SWITCHED RECEPTACLE
⊗	CEILING FIXTURE	⊕	220V RECEPTACLE
⊕K	KEYLESS	⊕GFCI	GFCI OUTLET
⊗K	WALL MOUNT FIXTURE	⊕AFCI	ARCH FAULT CIRCUIT INTERRUPTER
○	CEILING FIXTURE	†GL	GAS LINE
●	FLEX CONDUIT	†WL	WATER LINE
CH	CHIMES	⊥	HOSE BIBB
PH	TELEPHONE	⊕	FLOOD LIGHT
SD/Co	SMOKE DETECTOR & CARBON MONOXIDE	⊕	1x4 LUMINOUS FIXTURE
SO	SECURITY OUTLET	⊗	CEILING FAN
□	GARAGE DOOR OPENER	—	ELECTRICAL WIRING
⊕	EXHAUST FAN	⊕	CEILING FIXTURE
⊕	FAN/LIGHT		

ELECTRICAL PLANS TO FOLLOW ALL LOCAL CODES

APPROX. FIXTURE HGTS (MEASURED FROM BOTTOM OF FIXTURE)

BREAKFAST/DINING ROOM	63" ABOVE FINISHED FLOOR
KITCHEN PENDANT LIGHTS	33" ABOVE COUNTER TOP
TWO STORY FOYER FIXTURE	96" ABOVE FINISHED FLOOR
CEILING FAN	96" ABOVE FINISHED FLOOR

NOTE: FINAL PLACEMENT OF PHONE/CABLE T.B.D. ON SITE BY THE BUILDER

SECOND ELECTRICAL PLAN

SCALE: 1/8" = 1'-0"

BY	REVISION	#	#	#	#	#	#



ELECTRICAL PLAN
SECOND FLOOR
TELFAIR

SMITH DOUGLAS HOMES
110 VILLAGE TRAIL
SUITE 115
WOODSTOCK, GA 30188
www.smithdouglas.com

SMITH DOUGLAS HOMES expressly reserves its property rights in these plans and drawings. These plans and related drawings are not to be reproduced without written consent from SMITH DOUGLAS HOMES.

BY:	TJJ	CH:	AW
DATE:	10/14/2024		
FACADE OPT:	A		
PLAN ID:			
FND:	ALL	ELEV:	A
PAGE NO:	A7.3		

REFER TO LOT SPECIFIC PLAN TO DETERMINE WHICH DETAILS APPLY

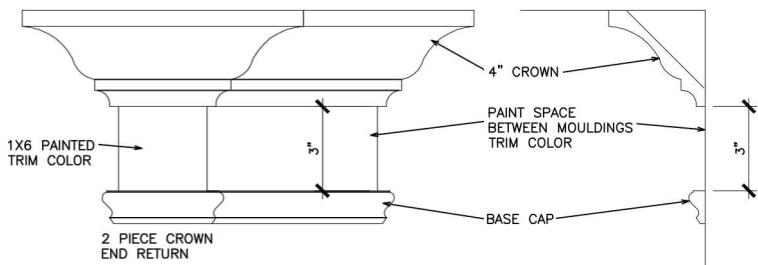

TYPICAL TWO PIECE CROWN

N.T.S.

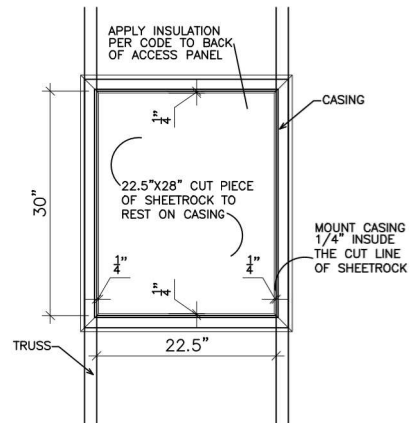

SCUTTLE HOLE DETAIL

N.T.S.

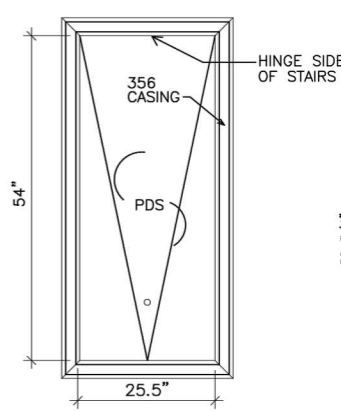

PDS TRIM DETAIL

N.T.S.

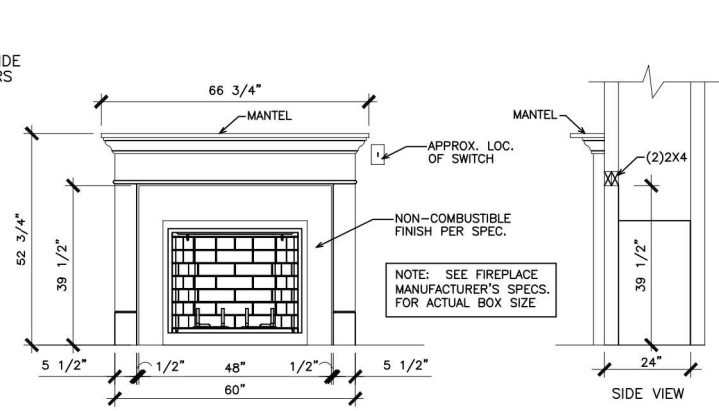

GAS/ELECTRIC FIREPLACE DETAIL WITH WESCOTT WOOD MANTEL

N.T.S.

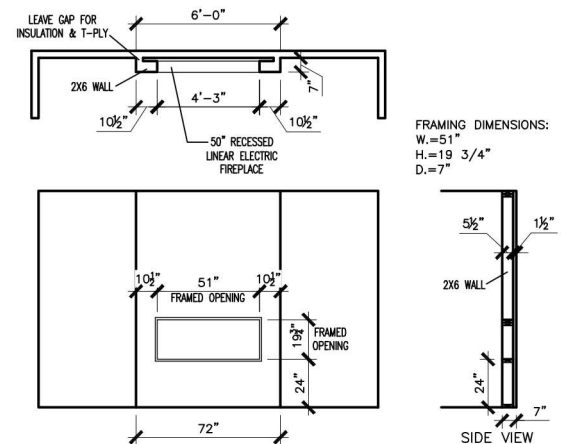

LINEAR ELECTRIC FIREPLACE DETAIL

N.T.S.

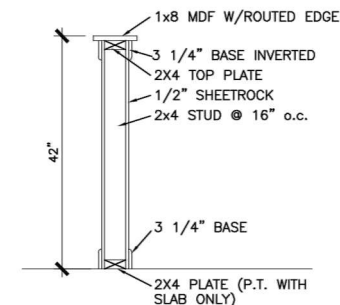

TYP. KNEEWALL SECTION

N.T.S.

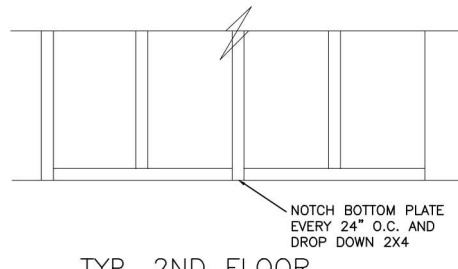

TYP. 2ND FLOOR KNEEWALL STABILITY

N.T.S.

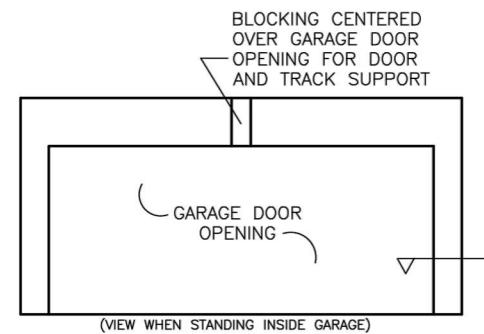

TYP. GARAGE WRAP & BLOCKING

N.T.S.

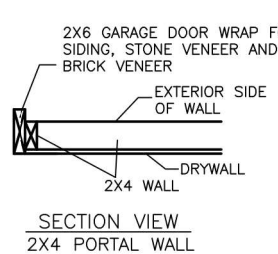

SECTION VIEW 2X4 PORTAL WALL

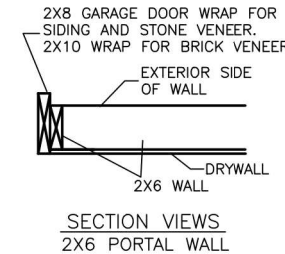

SECTION VIEWS 2X6 PORTAL WALL

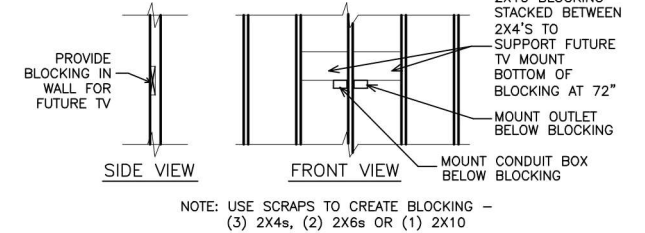

TYP. TV WALL PREP

N.T.S.

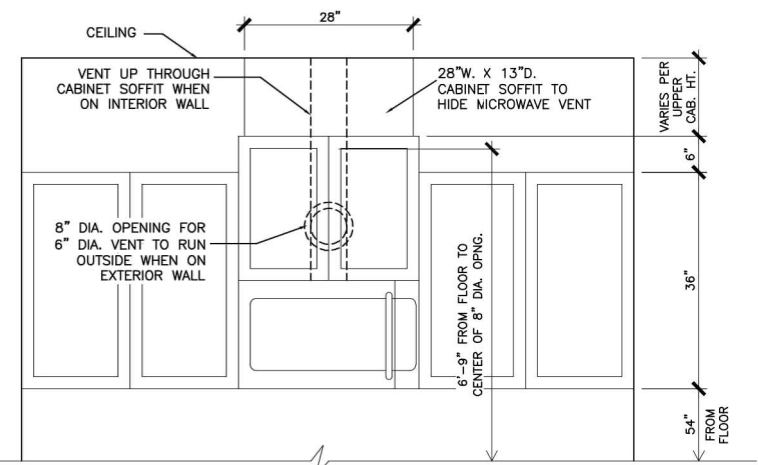

CABINET SOFFIT DETAIL ABOVE VENTED MICROWAVE W/CABINET ABOVE RANGE BUMPED UP & OUT

N.T.S.

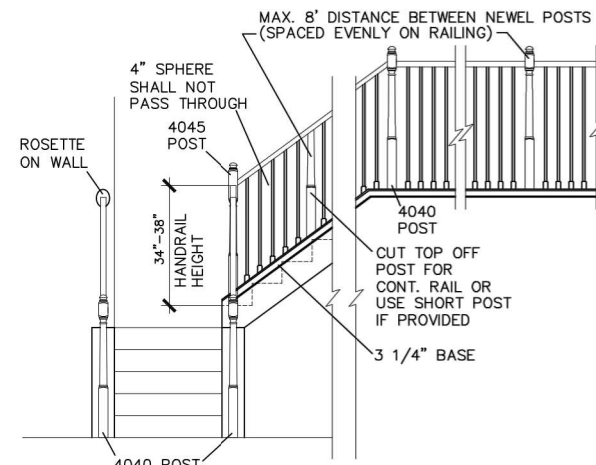

HANDRAIL/POST DETAIL @ STAIRS

N.T.S.

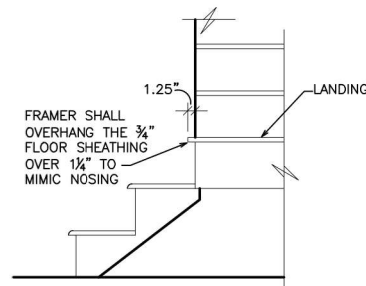

BOX STEP OVERHANG

N.T.S.

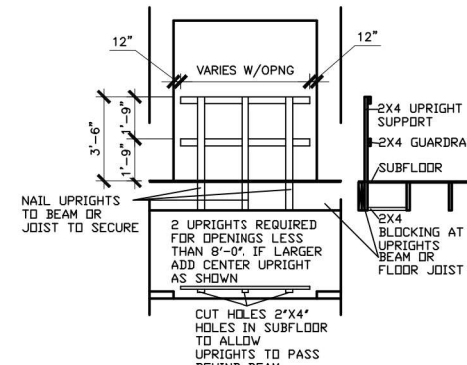

GUARD RAIL DTL. AS REQ'D

N.T.S.

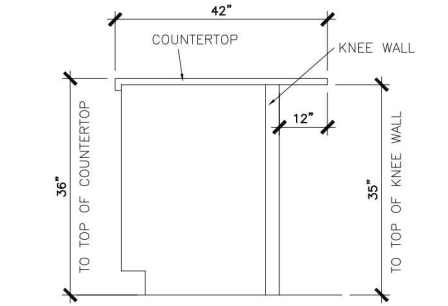

SECTION @ ISLAND KNEEWALL

N.T.S.

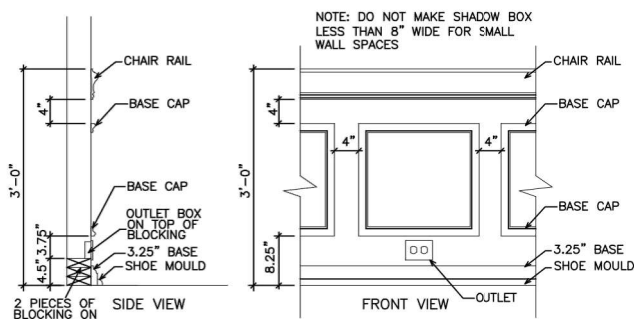

TYPICAL CHAIR RAIL & SHADOW BOX DETAIL

N.T.S.

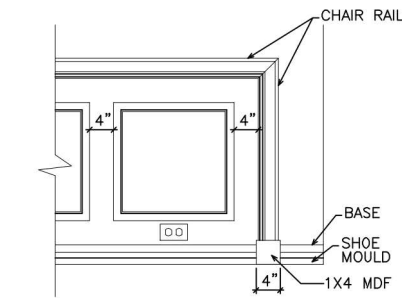

CHAIR RAIL END TRIM DETAIL

N.T.S.

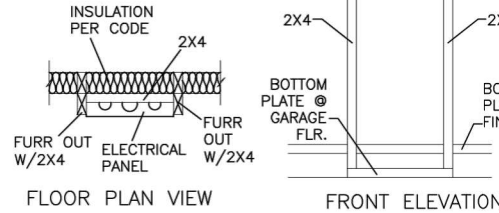

ELECTRICAL PANEL DETAIL

N.T.S.

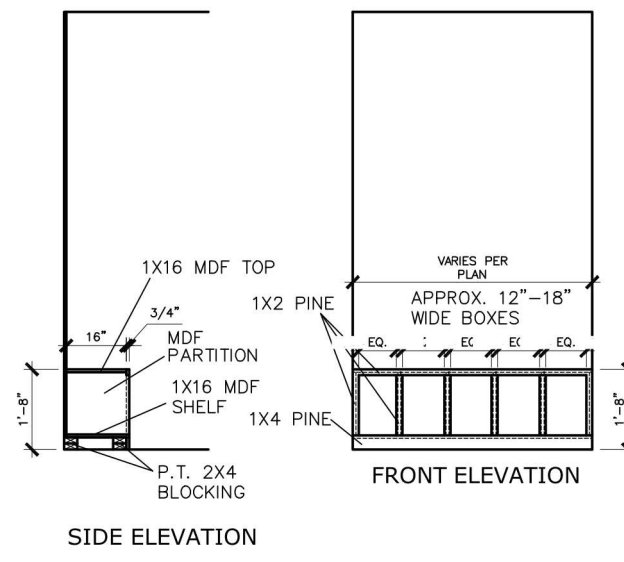

MUD ROOM BENCH SEAT DETAIL

N.T.S.

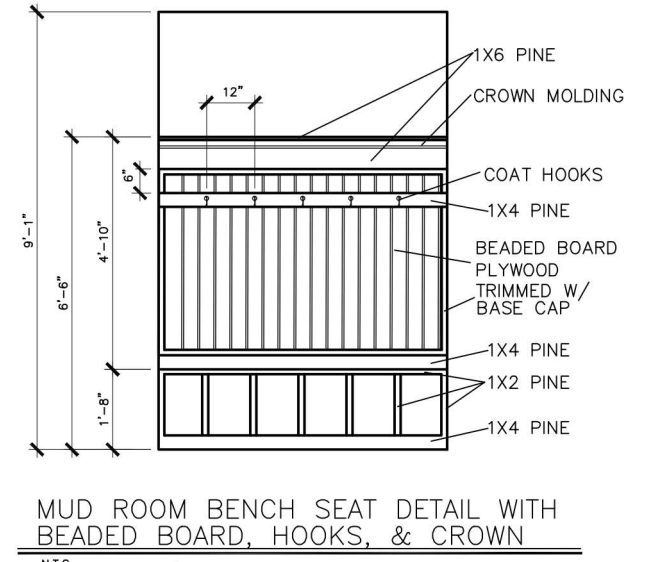

MUD ROOM BENCH SEAT DETAIL WITH BEADED BOARD, HOOKS, & CROWN

N.T.S.

(IF TRIM CHOSEN WITHOUT BENCH CONTINUE TO FLOOR)

© SMITH DOUGLAS HOMES 2023

BY	REVISION	DATE

SMITH DOUGLAS HOMES
QUALITY | INTEGRITY | VALUE

INTERIOR TRIM
DETAILS

SMITH DOUGLAS HOMES
110 VILLAGE TRAIL
SUITE 215
WOODSTOCK, GA 30188
www.smithdouglas.com

SMITH DOUGLAS HOMES expressly reserves its property rights in these plans and drawings. These plans and related drawings are not to be reproduced without written consent from SMITH DOUGLAS HOMES.

BY:	CH:
DATE:	6/13/23
PACKAGE OPT:	
PLAN ID:	
FND:	ELEV:
PAGE NO:	D1.1

DESIGN SPECIFICATIONS:

Construction Type: Commercial Residential

Applicable Building Codes:

- 2018 North Carolina Residential Building Code
- ASCE 7-10: Minimum Design Loads for Buildings and Other Structures

Design Loads:

- Roof
 - Live..... 20 PSF
 - Dead..... 10 PSF
 - Snow..... 15 PSF
 - Importance Factor..... 1.0
- Floor Live Loads
 - Typ. Dwelling..... 40 PSF
 - Sleeping Areas..... 30 PSF
 - Balconies (exterior) and Decks..... 40 PSF
 - Garage Parking..... 50 PSF
- Floor Dead Loads
 - Conventional 2x..... 10 PSF
 - 1-Joist..... 15 PSF
 - Floor Truss..... 15 PSF
- Ultimate Wind Speed (3 sec. gust)..... 130 MPH
 - Exposure..... B
 - Importance Factor..... 1.0
 - Wind Base Shear
 - V_x =
 - V_y =
- Component and Cladding (in PSF)

MEAN ROOF HT.	UP TO 30'	30'1"-35'	35'1"-40'	40'1"-45'
ZONE 1	16.7-18.0	17.5-18.9	18.2-19.6	18.7-20.2
ZONE 2	16.7-21.0	17.5-22.1	18.2-22.9	18.7-23.5
ZONE 3	16.7-21.0	17.5-22.1	18.2-22.9	18.7-23.5
ZONE 4	18.2-19.0	19.2-20.0	19.9-20.7	20.4-21.3
ZONE 5	18.2-24.0	19.2-25.2	19.9-26.1	20.4-26.9

6. Seismic

- Site Class..... D
- Design Category..... C
- Importance Factor..... 1.0
- Seismic Use Group..... 1
- Spectral Response Acceleration
 - S_{ms} = %g
 - S_{m1} = %g
- Seismic Base Shear
 - V_x =
 - V_y =
- Basic Structural System (check one)
 - Bearing Wall
 - Building Frame
 - Moment Frame
 - Dual w/ Special Moment Frame
 - Dual w/ Intermediate R/C or Special Steel
 - Inverted Pendulum
- Arch/Mech Components Anchored?..... No
- Lateral Design Control: Seismic Wind
- Assumed Soil Bearing Capacity..... 2000psf

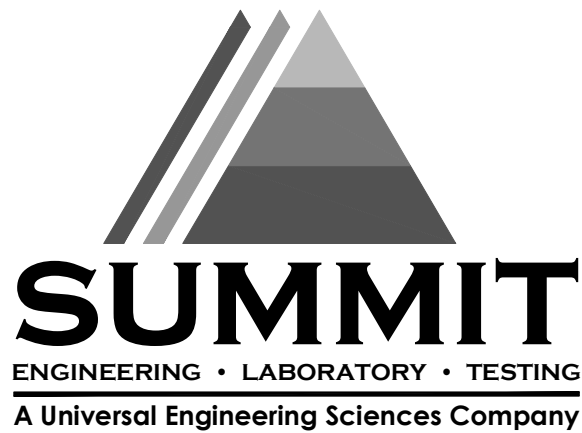

STRUCTURAL PLANS PREPARED FOR:

TELFAIR

PROJECT ADDRESS:

TBD

OWNER:

Smith Douglas Homes - Raleigh
2520 Reliance Ave
Apex, NC 27539

ARCHITECT/DESIGNER:

Smith Douglas Homes
110 Village Trail, Suite 215
Woodstock, GA 30188

These drawings are to be coordinated with the architectural, mechanical, plumbing, electrical, and civil drawings. This coordination is not the responsibility of the structural engineer of record (SER). Should any discrepancies become apparent, the contractor shall notify SUMMIT Engineering, Laboratory & Testing, INC. before construction begins.

PLAN ABBREVIATIONS:

AB	ANCHOR BOLT	PT	PRESSURE TREATED
AFF	ABOVE FINISHED FLOOR	RS	ROOF SUPPORT
CJ	CEILING JOIST	SC	STUD COLUMN
CLR	CLEAR	SJ	SINGLE JOIST
DJ	DOUBLE JOIST	SFF	SPRUCE PINE FIR
DSP	DOUBLE STUD POCKET	SST	SIMPSON STRONG-TIE
EE	EACH END	SYP	SOUTHERN YELLOW PINE
EW	EACH WAY	TJ	TRIPLE JOIST
NTS	NOT TO SCALE	TSP	TRIPLE STUD POCKET
OC	ON CENTER	TYP	TYPICAL
PSF	POUNDS PER SQUARE FOOT	UNO	UNLESS NOTED OTHERWISE
PSI	POUNDS PER SQUARE INCH	WUF	WELDED WIRE FABRIC

Roof truss and floor joist layouts, and their corresponding loading details, were not provided to SUMMIT Engineering, Laboratory & Testing, INC. (SUMMIT) prior to the initial design. Therefore, truss and joist directions were assumed based on the information provided by SMITH DOUGLAS HOMES. Subsequent plan revisions based on roof truss and floor joist layouts shall be noted in the revision list, indicating the date the layouts were provided. Should any discrepancies become apparent, the contractor shall notify SUMMIT immediately.

SHEET LIST:

Sheet No.	Description
CS1	Cover Sheet, Specifications, Revisions
CS2	Specifications Continued
SI.0m	Monolithic Slab Foundation
SI.0s	Stem Wall Foundation
SI.0c	Crawl Space Foundation
SI.0b	Basement Foundation
S2.0	Basement Framing Plan
S3.0	First Floor Framing Plan
S4.0	Second Floor Framing Plan
S5.0	Roof Framing Plan
S6.0	Basement Bracing Plan
S7.0	First Floor Bracing Plan
S8.0	Second Floor Bracing Plan

REVISION LIST:

Revision No.	Date	Project No.	Description
0	9.24.19	303	Original Drawing
1	9.30.19	303R	Revised per brick loading
2	1.28.20	318	Added optional 2nd floor
3	1.31.20	318R	Added load-bearing wall in basement
4	2.7.20	318R2	Updated per new truss drawings
5	6.29.21	3832.T0034	Added LIB Bracing Options
6	8.23.22	3832.T0034	Revised Garage Header Sizes
7	11.15.22	3832.T0041	Updated Garage opening on Bracing Plans

BRIARWOOD
Lot 6

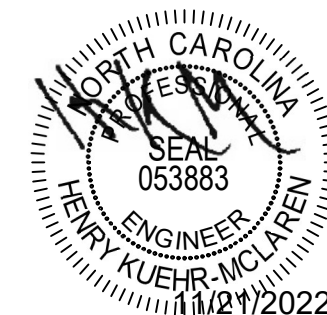

STRUCTURAL MEMBERS ONLY

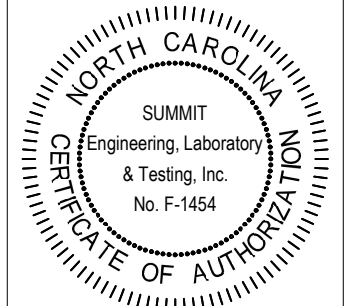

PROJECT
Telfair RH
Coversheet
CLIENT
Smith Douglas Homes - Raleigh
2520 Reliance Ave
Apex, NC 27539

CURRENT DRAWING

DATE: 11/15/2022

SCALE: 1/8"=1'-0"

PROJECT #: 3832.T0041

DRAWN BY: EO

CHECKED BY: HKM

ORIGINAL DRAWING

DATE PROJECT #

09/24/2019 3832.303

REFER TO COVER SHEET FOR A COMPLETE LIST OF REVISIONS

SHEET

CS1

GENERAL STRUCTURAL NOTES:

- The design professional whose seal appears on these drawings is the structural engineer of record (SER) for this project. The SER bears the responsibility of the primary structural elements and the performance of this structure. No other party may revise, alter, or delete any structural aspects of these construction documents without written permission of SUMMIT Engineering, Laboratory & Testing, INC. (SUMMIT) or the SER. For the purposes of these construction documents the SER and SUMMIT shall be considered the same entity.
- The structure is only stable in its completed form. The contractor shall provide all required temporary bracing during construction to stabilize the structure.
- The SER is not responsible for construction sequences, methods, or techniques in connection with the construction of this structure. The SER will not be held responsible for the contractor's failure to conform to the contract documents, should any non-conformities occur.
- Any structural elements or details not fully developed on the construction drawings shall be completed under the direction of a licensed professional engineer. These shop drawings shall be submitted to SUMMIT for review before any construction begins. The shop drawings will be reviewed for overall compliance as it relates to the structural design of this project. Verification of the shop drawings for dimensions, or for actual field conditions, is not the responsibility of the SER or SUMMIT.
- Verification of assumed field conditions is not the responsibility of the SER. The contractor shall verify the field conditions for accuracy and report any discrepancies to SUMMIT before construction begins.
- The SER is not responsible for any secondary structural elements or non-structural elements, except for the elements specifically noted on the structural drawings.
- This structure and all construction shall conform to all applicable sections of the international residential code.
- This structure and all construction shall conform to all applicable sections of the 2018 North Carolina Residential Code (NCRC) and any local codes or restrictions.

FOUNDATIONS:

- Foundations shall be constructed in accordance with chapter 4 of the 2018 NC Residential Building Code (Special consideration shall be given to Chapter 45 in wind zones above 130mph)
- Footings sizes based on a presumptive soil bearing capacity of 2000 PSF. Contractor is solely responsible for verifying the suitability of the site soil conditions at the time of construction
- Maximum depth of unbalanced fill against masonry walls to be as specified in section R404.1 of the 2018 NCRC
- The structural engineer has not performed a subsurface investigation. Verification of this assumed value is the responsibility of the owner or the contractor. Should any adverse soil condition be encountered the SER must be contacted before proceeding.
- The bottom of all footings shall extend below the frost line for the region in which the structure is to be constructed. However, the bottom of all footings shall be a minimum of 12" below grade.
- Any fill shall be placed under the direction or recommendation of a licensed professional engineer. The resulting soil shall be compacted to a minimum of 95% maximum dry density.
- Excavations of footings shall be lined temporarily with a 6 mil polyethylene membrane if placement of concrete does not occur within 24 hours of excavation.
- No concrete shall be placed against any subgrade containing water, ice, frost, or loose material.
- Each crawl space pier shall bear in the middle third of its respective footing and each girder shall bearing in the middle third of the piers. Pilasters to be bonded to perimeter foundation wall
- Crawl spaced to be graded level and clear of all debris
- Provide foundation waterproofing and drain with positive slope to outlet as required by site conditions
- Energy efficiency compliance and insulation of the structure to be in accordance with chapter 11 of the 2018 NCRC

CONCRETE:

- Concrete shall have a normal weight aggregate and a minimum compressive strength (f'c) at 28 days of 3000 psi, unless otherwise noted on the plan.
- Concrete shall be proportioned, mixed, and placed in accordance with the latest editions of ACI 318: "Building Code Requirements for Reinforced Concrete" and ACI 301: "Specifications for Structural Concrete for Buildings".
- Air entrained concrete must be used for all structural elements exposed to freeze/thaw cycles and deicing chemicals. Air entrainment amounts (in percent) shall be within -1% to +2% of target values as follows:
 - Footings: 5%
 - Exterior Slabs: 5%
- No admixtures shall be added to any structural concrete without written permission of the SER
- Concrete slabs-on-grade shall be constructed in accordance with ACI 302.1R-96: "Guide for Concrete Slab and Slab Construction".
- The concrete slab-on-grade has been designed using a subgrade modulus of k=250 pci and a design loading of 200 psf. The SER is not responsible for differential settlement, slab cracking or other future defects resulting from unreported conditions not in accordance with the above assumptions.
- Control or saw cut joints shall be spaced in interior slabs-on-grade at a maximum of 15'-0" O.C. and in exterior slabs-on-grade at a maximum of 10'-0" unless otherwise noted.
- Control or saw cut joints shall be produced using conventional process within 4 to 12 hours after the slab has been finished
- Reinforcing steel may not extend through a control joint. Reinforcing steel may extend through a saw cut joint.
- All welded wire fabric (WWF) for concrete slabs-on-grade shall be placed at mid-depth of slab. The WWF shall be securely supported during the concrete pour. Fibermesh may be used in lieu of WWF.

CONCRETE REINFORCEMENT:

- Fibrous concrete reinforcement, or fibermesh, specified in concrete slabs-on-grade may be used for control of cracking due to shrinkage and thermal expansion/contraction, lowered water migration, an increase in impact capacity, increased abrasion resistance, and residual strength.
- Fibermesh reinforcing to be 100% virgin polypropylene fibers containing no reprocessed olefin materials and specifically manufactured for use as concrete secondary reinforcement.
- Application of fibermesh per cubic yard of concrete shall equal a minimum of 0.1% by volume (15 pounds per cubic yard)
- Fibermesh shall comply with ASTM C1116, any local building code requirements, and shall meet or exceed the current industry standard.
- Steel Reinforcing bars shall be new billet steel conforming to ASTM A615, grade 60.
- Detailing, fabrication, and placement of reinforcing steel shall be in accordance with the latest edition of ACI 315: "Manual of Standard Practice for Detailing Concrete Structures"
- Horizontal footing and wall reinforcement shall be continuous and shall have 90° bends, or corner bars with the same size/spacing as the horizontal reinforcement with a class B tension splice.
- Lap reinforcement as required, a minimum of 40 bar diameters for tension or compression unless otherwise noted. Splices in masonry shall be a minimum of 48 bar diameters.
- Where reinforcing dowels are required, they shall be equivalent in size and spacing to the vertical reinforcement. The dowel shall extend 48 bar diameters vertically and 20 bar diameters into the footing.
- Where reinforcing steel is required vertically, dowels shall be provided unless otherwise noted.

WOOD FRAMING:

- Solid sawn wood framing members shall conform to the specifications listed in the latest edition of the "National Design Specification for Wood Construction" (NDS). Unless otherwise noted, all wood framing members are designed to be Spruce-Pine-Fir (SPF) #2.
- LVL or PSL engineered wood shall have the following minimum design values:
 - E = 1,900,000 psi
 - Fb = 2600 psi
 - Fv = 285 psi
 - Fc = 100 psi
- Wood in contact with concrete, masonry, or earth shall be pressure treated in accordance with AWPA standard C-15. All other moisture exposed wood shall be treated in accordance with AWPA standard C-2
- Nails shall be common wire nails unless otherwise noted.
- Lag screws shall conform to ANSI/ASME standard B18.21-1981. Lead holes for lag screws shall be in accordance with NDS specifications.
- All beams shall have full bearing on supporting framing members unless otherwise noted.
- Exterior and load bearing stud walls are to be 2x4 SPF#2 @16" O.C. unless otherwise noted. Studs shall be continuous from the sole plate to the double top plate. Studs shall only be discontinuous at headers for window/door openings. A minimum of one king stud shall be placed at each end of the header. King studs shall be continuous.
- Individual studs forming a column shall be attached with one 10d nail @6" O.C. staggered. The stud column shall be fully blocked to the foundation or beam. The column shall be fully blocked at all floor levels to ensure proper load transfer.
- Multi-ply beams shall have each ply attached with (3)10d nails @ 24" O.C.
- Fitch beams and four and five ply beams shall be bolted together with (2) rows of 1/2" dia. through bolts staggered @24" O.C. w/ 2" edge distance and (2) bolts located at 6" from each end, unless noted otherwise.

WOOD TRUSSES:

- The wood truss manufacturer/fabricator is responsible for the design of the wood trusses. Submit sealed shop drawings and supporting calculations to the SER for review prior to fabrication. The SER shall have a minimum of five (5) days for review. The review by the SER shall review for overall compliance with the design documents. The SER shall assume no responsibility for the correctness for the structural design for the wood trusses.
- The wood trusses shall be designed for all required loadings as specified in the local building code, the ASCE Standard "Minimum Design Loads for Buildings and Other Structures." (ASCE 7-10), and the loading requirements shown on these specifications. The truss drawings shall be coordinated with all other construction documents and provisions provided for loads shown on these drawings including but not limited to HVAC equipment, piping, and architectural fixtures attached to the trusses.
- The trusses shall be designed, fabricated, and erected in accordance with the latest edition of the "National Design Specification for Wood Construction." (NDS) and "Design Specification for Metal Plate Connected Wood Trusses."
- The truss manufacturer shall provide adequate bracing information in accordance with "Commentary and Recommendations for Handling, Installing, and Bracing Metal Plate Connected Wood Trusses" (HIB-91). This bracing, both temporary and permanent, shall be shown on the shop drawings. Also, the shop drawings shall show the required attachments for the trusses.
- Any chords or truss webs shown on these drawings have been shown as a reference only. The final design of the trusses shall be per the manufacturer.

WOOD STRUCTURAL PANELS:

- Fabrication and placement of structural wood sheathing shall be in accordance with the APA Design/Construction Guide "Residential and Commercial," and all other applicable APA standards.
- All structurally required wood sheathing shall bear the mark of the APA.
- Wood wall sheathing shall comply with the requirements of local building codes for the appropriate state as indicated on these drawings. Refer to wall bracing notes in plan set for more information. Sheathing shall be applied with the long direction perpendicular to framing, unless noted otherwise.
- Roof sheathing shall be APA rated sheathing exposure 1 or 2. Roof sheathing shall be continuous over two supports and attached to its supporting roof framing with (1)-8d CC nail at 6"o/c at panel edges and at 12"o/c in panel field unless otherwise noted on the plans. Sheathing shall be applied with the long direction perpendicular to framing. Sheathing shall have a span rating consistent with the framing spacing. Use suitable edge support by use of plywood clips or lumber blocking unless otherwise noted. Panel end joints shall occur over framing. Apply building paper over the sheathing as required by the state Building Code.
- Wood floor sheathing shall be APA rated sheathing exposure 1 or 2. Attach sheathing to its supporting framing with (1)-8d CC ringshank nail at 6"o/c at panel edges and at 12"o/c in panel field unless otherwise noted on the plans. Sheathing shall be applied perpendicular to framing. Sheathing shall have a span rating consistent with the framing spacing. Use suitable edge support by use of T4G plywood or lumber blocking unless otherwise noted. Panel end joints shall occur over framing. Apply building paper over the sheathing as required by the state Building Code.
- Sheathing shall have a 1/8" gap at panel ends and edges as recommended in accordance with the APA.

STRUCTURAL FIBERBOARD PANELS:

- Fabrication and placement of structural fiberboard sheathing shall be in accordance with the applicable AFA standards.
- Fiberboard wall sheathing shall comply with the requirements of local building codes for the appropriate state as indicated on these drawings. Refer to wall bracing notes in plan set for more information.
- Sheathing shall have a 1/8" gap at panel ends and edges as recommended in accordance with the AFA.

EXTERIOR WOOD FRAMED DECKS:

- Decks are to be framed in accordance with local building codes and as referenced on the structural plans, either through code references or construction details.

STRUCTURAL STEEL:

- Structural steel shall be fabricated and erected in accordance with the American Institute of Steel Construction "Code of Standard Practice for Steel Buildings and Bridges" and of the manual of Steel Construction "Load Resistance Factor Design" latest editions.
- All steel shall have a minimum yield stress (Fy) of 36 ksi unless otherwise noted.
- Welding shall conform to the latest edition of the American Welding Society's Structural Welding Code AWS D11. Electrodes for shop and field welding shall be class E70XX. All welding shall be performed by a certified welder per the above standards.

**BRIARWOOD
Lot 6**

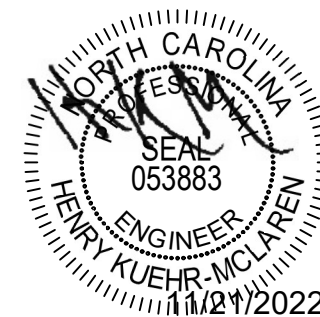

STRUCTURAL MEMBERS ONLY

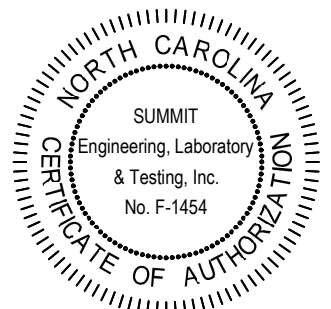

PROJECT
Telfair RH
Coversheet
CLIENT
Smith Douglas Homes - Raleigh
2520 Reliance Ave
Apex, NC 27539

CURRENT DRAWING

DATE: 11/15/2022
SCALE: 1/8"=1'-0"
PROJECT #: 3832.10041
DRAWN BY: EO
CHECKED BY: HKM

ORIGINAL DRAWING

DATE PROJECT #
09/24/2019 3832.303

REFER TO COVER SHEET FOR A COMPLETE LIST OF REVISIONS

SHEET

CS2

- FOUNDATION NOTES:**
- FOUNDATIONS TO BE CONSTRUCTED IN ACCORDANCE WITH CHAPTER 4 OF THE 2018 NORTH CAROLINA RESIDENTIAL BUILDING CODE WITH ALL LOCAL AMENDMENTS.
 - STRUCTURAL CONCRETE TO BE Fc = 3000 PSI, PREPARED AND PLACED IN ACCORDANCE WITH ACI STANDARD 318.
 - FOOTINGS TO BE PLACED ON UNDISTURBED EARTH, BEARING A MINIMUM OF 12" BELOW ADJACENT FINISHED GRADE, OR AS OTHERWISE DIRECTED BY THE CODE ENFORCEMENT OFFICIAL.
 - FOOTING SIZES BASED ON A PRESUMPTIVE SOIL BEARING CAPACITY OF 1000 PSF. CONTRACTOR IS SOLELY RESPONSIBLE FOR VERIFYING THE SUITABILITY OF THE SITE SOIL CONDITIONS AT THE TIME OF CONSTRUCTION.
 - FOOTINGS AND PIERS SHALL BE CENTERED UNDER THEIR RESPECTIVE ELEMENTS. PROVIDE 2" MINIMUM FOOTING PROJECTION FROM THE FACE OF MASONRY.
 - MAXIMUM DEPTH OF UNBALANCED FILL AGAINST MASONRY WALLS TO BE AS SPECIFIED IN SECTION R404.1 OF THE 2018 NORTH CAROLINA RESIDENTIAL BUILDING CODE.
 - PILASTERS TO BE BONDED TO PERIMETER FOUNDATION WALL.
 - PROVIDE FOUNDATION WATERPROOFING, AND DRAIN WITH POSITIVE SLOPE TO OUTLET AS REQUIRED BY SITE CONDITIONS.
 - PROVIDED PERIMETER INSULATION FOR ALL FOUNDATIONS PER 2018 NORTH CAROLINA RESIDENTIAL BUILDING CODE.
 - CORBEL FOUNDATION WALL AS REQUIRED TO ACCOMMODATE BRICK VENEERS.
 - CRAILL SPACE TO BE GRADED LEVEL, AND CLEARED OF ALL DEBRIS.
 - FOUNDATION ANCHORAGE SHALL BE CONSTRUCTED PER THE 2018 NORTH CAROLINA RESIDENTIAL BUILDING CODE SECTION R403.1.6, MINIMUM 1/2" DIA. BOLTS SPACED AT 6'-0" ON CENTER WITH A 1" MINIMUM EMBEDMENT INTO MASONRY OR CONCRETE. ANCHOR BOLTS SHALL BE 1" FROM THE END OF EACH PLATE SECTION. MINIMUM (2) ANCHOR BOLTS PER PLATE SECTION. ANCHOR BOLTS SHALL BE LOCATED IN THE CENTER THIRD OF THE PLATE.
 - ABBREVIATIONS:

DJ = DOUBLE JOIST	SJ = SINGLE JOIST
GT = GIRDER TRUSS	FT = FLOOR TRUSS
SC = STUD COLUMN	DR = DOUBLE RAFTER
EE = EACH END	TR = TRIPLE RAFTER
TJ = TRIPLE JOIST	OC = ON CENTER
CL = CENTER LINE	PL = POINT LOAD
 - ALL PIERS TO BE 16"x16" MASONRY AND ALL PILASTERS TO BE 8"x16" MASONRY, TYPICAL (UNO).
 - WALL FOOTINGS TO BE CONTINUOUS CONCRETE, SIZES PER STRUCTURAL PLAN.
 - A FOUNDATION EXCAVATION OBSERVATION SHOULD BE CONDUCTED BY A PROFESSIONAL GEOTECHNICAL ENGINEER OR HIS QUALIFIED REPRESENTATIVE. IF ISOLATED AREAS OF YIELDING MATERIALS AND/OR POTENTIALLY EXPANSIVE SOILS ARE OBSERVED IN THE FOOTING EXCAVATIONS AT THE TIME OF CONSTRUCTION, SUMMIT ENGINEERING, LABORATORY & TESTING, INC. MUST BE PROVIDED THE OPPORTUNITY TO REVIEW THE FOOTING DESIGN PRIOR TO CONCRETE PLACEMENT.
 - ALL FOOTINGS & SLABS ARE TO BEAR ON UNDISTURBED SOIL OR 95% COMPACTED FILL, VERIFIED BY ENGINEER OR CODE OFFICIAL.

REFER TO BRACED WALL PLAN FOR PANEL LOCATIONS AND ANY REQUIRED HOLDDOWNS. ADDITIONAL INFO. PER SECTION R602.10.4 AND FIGURE R602.10.3(4) OF THE 2018 NCR. C.

NOTE: ALL EXTERIOR FOUNDATION DIMENSIONS ARE TO FRAMING AND NOT BRICK VENEER, UNO

THESE PLANS ARE DESIGNED IN ACCORDANCE WITH ARCHITECTURAL PLANS PROVIDED BY SMITH DOUGLAS HOMES. COMPLETED/REVISED ON 8/10/2022. IT IS THE RESPONSIBILITY OF THE CLIENT TO NOTIFY SUMMIT ENGINEERING, LABORATORY & TESTING, INC. IF ANY CHANGES ARE MADE TO THE ARCHITECTURAL PLANS PRIOR TO CONSTRUCTION. SUMMIT ENGINEERING, LABORATORY & TESTING, INC. CANNOT GUARANTEE THE ADEQUACY OF THESE STRUCTURAL PLANS WHEN USED WITH ARCHITECTURAL PLANS DATED DIFFERENTLY THAN THE DATE LISTED ABOVE.

NOTE: A 4" CRUSHED STONE BASE COURSE IS NOT REQUIRED WHEN SLAB IS INSTALLED ON WELL-DRAINED OR SAND-GRAVEL MIXTURE SOILS CLASSIFIED AS GROUP 1 PER TABLE R409.

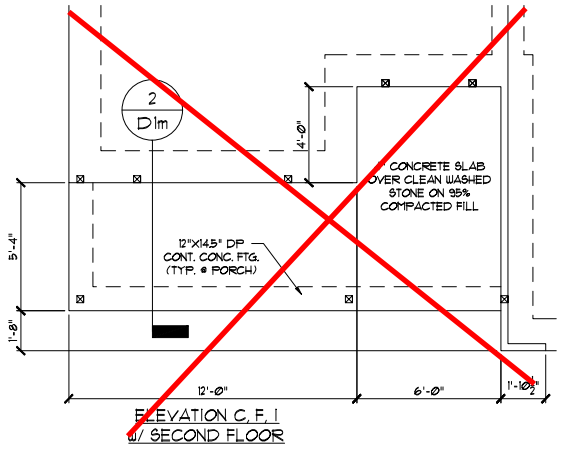
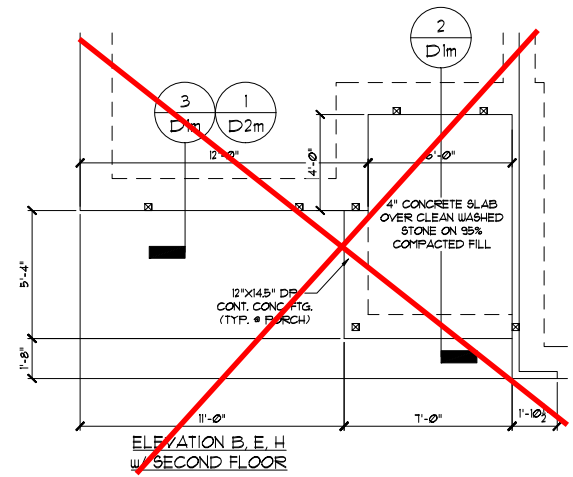
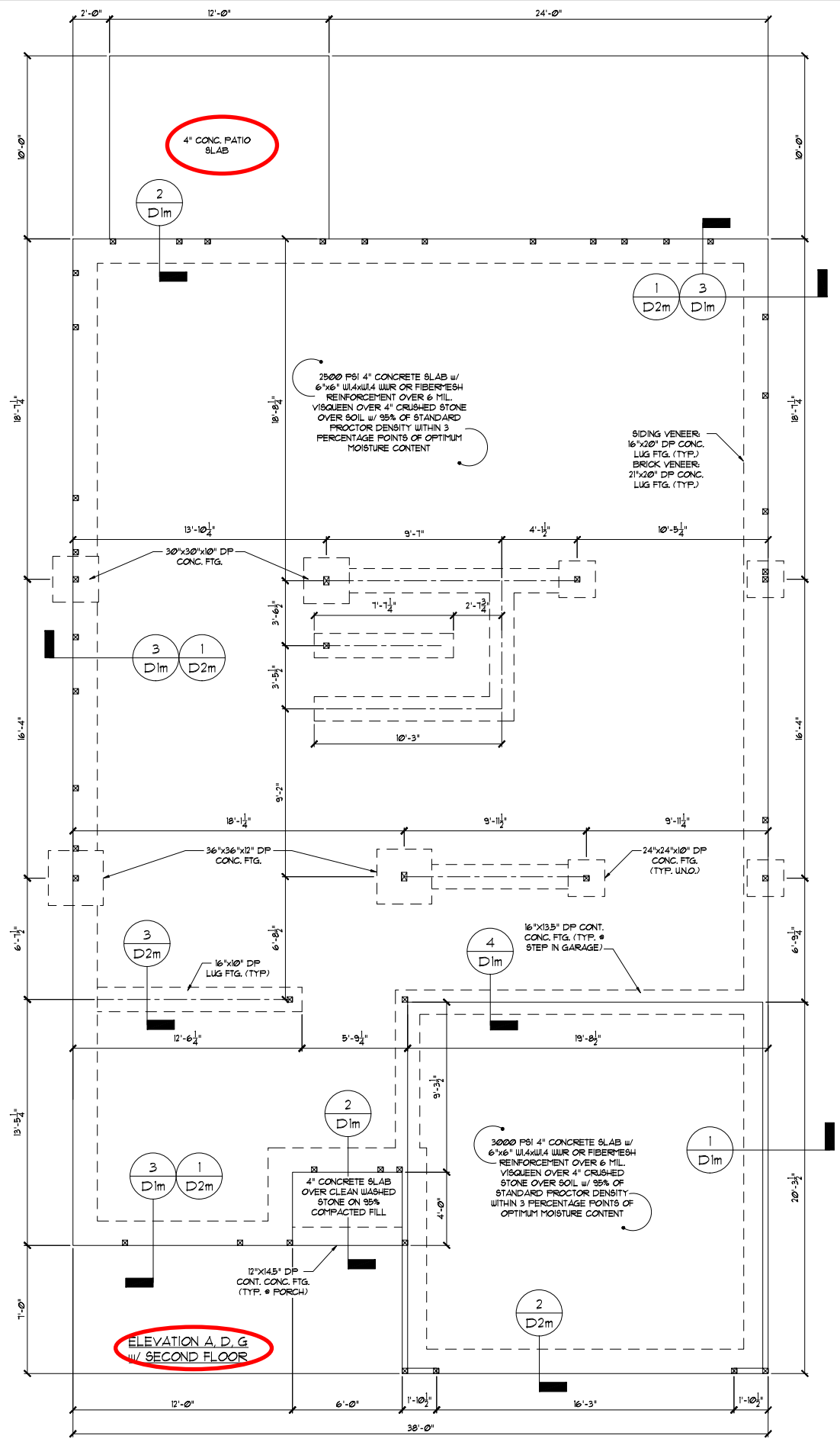

STRUCTURAL MEMBERS ONLY
 ENGINEERING SEAL APPLIES ONLY TO STRUCTURAL COMPONENTS ON THIS DOCUMENT. SEAL DOES NOT INCLUDE CONSTRUCTION MEANS, METHODS, TECHNIQUES, SEQUENCES, PROCEDURES OR SAFETY PRECAUTIONS. ANY DEVIATIONS OR DISCREPANCIES ON PLANS ARE TO BE BROUGHT TO THE IMMEDIATE ATTENTION OF SUMMIT ENGINEERING, LABORATORY & TESTING, INC. FAILURE TO DO SO WILL VOID SUMMIT LIABILITY.

STRUCTURAL ANALYSIS BASED ON 2018 NCR. C.

MONOLITHIC SLAB FOUNDATION
 SCALE: 1/8"=1'-0"

BRIARWOOD
 Lot 6

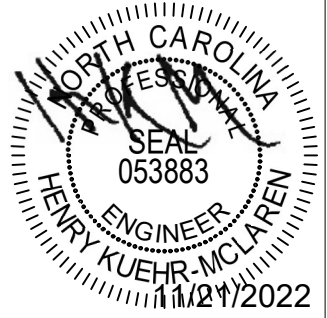

STRUCTURAL MEMBERS ONLY

SUMMIT
 ENGINEERING • LABORATORY • TESTING
 A Universal Engineering Sciences Company
 2520 Whitehall Park Dr, Suite 250
 Charlotte, NC 28273
 Office: 704.504.1717
 Fax: 704.504.1125
 www.summit-companies.com

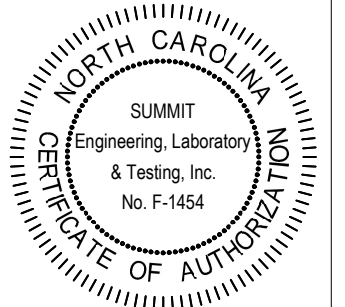

PROJECT
Telfair RH
Monolithic Slab Fnd.
 CLIENT
Smith Douglas Homes - Raleigh
2520 Reliance Ave
Apex, NC 27539

CURRENT DRAWING
 DATE: 11/15/2022
 SCALE: 1/8"=1'-0"
 PROJECT #: 3832.10041
 DRAWN BY: EO
 CHECKED BY: HKM

ORIGINAL DRAWING
 DATE PROJECT #
 09/24/2019 3832.303

REFER TO COVER SHEET FOR A COMPLETE LIST OF REVISIONS

SHEET
S1.2m

GENERAL STRUCTURAL NOTES:

- CONSTRUCTION SHALL CONFORM TO 2018 NORTH CAROLINA RESIDENTIAL BUILDING CODE WITH ALL LOCAL AMENDMENTS.
- CONTRACTOR SHALL VERIFY ALL DIMENSIONS. CONTRACTOR SHALL COMPLY WITH THE CONTENTS OF THE DRAWING FOR THIS SPECIFIC PROJECT. ENGINEER IS NOT RESPONSIBLE FOR ANY DEVIATIONS FROM THIS PLAN.
- CONTRACTOR IS RESPONSIBLE FOR PROVIDING TEMPORARY BRACING REQUIRED TO RESIST ALL FORCES ENCOUNTERED DURING ERECTION.
- PROPERTIES USED IN THE DESIGN ARE AS FOLLOWS:
MICRO-LAM (LVL): $F_b = 2600$ PSI, $F_v = 285$ PSI, $E = 1.9 \times 10^6$ PSI
PARALLAM (PSL): $F_b = 2300$ PSI, $F_v = 290$ PSI, $E = 1.25 \times 10^6$ PSI
- ALL WOOD MEMBERS SHALL BE #2 SFR UNLESS NOTED ON PLAN. ALL STUD COLUMNS AND JOISTS SHALL BE #2 SFR (UNO).
- ALL BEAMS SHALL BE SUPPORTED WITH A (2) 2x4 #2 SFR STUD COLUMN AT EACH END UNLESS NOTED OTHERWISE.
- ALL REINFORCING STEEL SHALL BE GRADE 60 BARS CONFORMING TO ASTM A615 AND SHALL HAVE A MINIMUM COVER OF 3".
- FOUNDATION ANCHORAGE SHALL BE CONSTRUCTED PER THE 2018 NORTH CAROLINA RESIDENTIAL CODE SECTION R403.1.6. MINIMUM 1/2" DIA. BOLTS SPACED AT 6'-0" ON CENTER WITH A 1" MINIMUM EMBEDMENT INTO MASONRY OR CONCRETE. ANCHOR BOLTS SHALL BE 12" FROM THE END OF EACH PLATE SECTION. MINIMUM (2) ANCHOR BOLTS PER PLATE SECTION. ANCHOR BOLTS SHALL BE LOCATED IN THE CENTER THIRD OF THE PLATE.
- CONTRACTOR TO PROVIDED LOOKOUTS WHEN CEILING JOISTS SPAN PERPENDICULAR TO RAFTERS.
- FLITCH BEAMS, 4-PLY LVL'S AND 3-PLY SIDE LOADED LVL'S SHALL BE BOLTED TOGETHER WITH 1/2" DIA. THRU BOLTS SPACED AT 24" O.C. STAGGERED OR EQUIVALENT CONNECTIONS PER DETAIL 2/D/T. MIN. EDGE DISTANCE SHALL BE 2" AND (2) BOLTS SHALL BE LOCATED MINIMUM 6" FROM EACH END OF THE BEAM.
- ALL NON-LOAD BEARING HEADERS SHALL BE (1) FLAT 2x4 SFR #2, DROPPED. FOR NON-LOAD BEARING HEADERS EXCEEDING 8'-0" IN WIDTH AND/OR WITH MORE THAN 2'-0" OF CRIPPLE WALL ABOVE, SHALL BE (2) FLAT 2x4 SFR #2, DROPPED. (UNLESS NOTED OTHERWISE)
- ABBREVIATIONS:

- | | |
|-------------------|--------------------|
| DJ = DOUBLE JOIST | SJ = SINGLE JOIST |
| GT = GIRDER TRUSS | FT = FLOOR TRUSS |
| SC = STUD COLUMN | DR = DOUBLE RAFTER |
| EE = EACH END | TR = TRIPLE RAFTER |
| TJ = TRIPLE JOIST | OC = ON CENTER |
| CL = CENTER LINE | PL = POINT LOAD |

NOTE: DESIGNATES JOIST SUPPORTED LOAD BEARING WALL ABOVE. PROVIDE BLOCKING UNDER JOIST SUPPORTED LOAD BEARING WALL.

NOTE: SHADED WALLS INDICATE LOAD BEARING WALLS

JOIST & BEAM SIZES SHOWN ARE MINIMUMS. BUILDER MAY INCREASE DEPTH FOR EASE OF CONSTRUCTION.

NOTE: REDUCE JOIST SPACING UNDER TILE FLOORS, GRANITE COUNTERTOPS AND/OR ISLANDS.

THESE PLANS ARE DESIGNED IN ACCORDANCE WITH ARCHITECTURAL PLANS PROVIDED BY SMITH DOUGLAS HOMES COMPLETED/REVISED ON 8/20/2022. IT IS THE RESPONSIBILITY OF THE CLIENT TO NOTIFY SUMMIT ENGINEERING, LABORATORY & TESTING, INC. IF ANY CHANGES ARE MADE TO THE ARCHITECTURAL PLANS PRIOR TO CONSTRUCTION. SUMMIT ENGINEERING, LABORATORY & TESTING, INC. CANNOT GUARANTEE THE ADEQUACY OF THESE STRUCTURAL PLANS WHEN USED WITH ARCHITECTURAL PLANS DATED DIFFERENTLY THAN THE DATE LISTED ABOVE.

STRUCTURAL MEMBERS ONLY

ENGINEERING SEAL APPLIES ONLY TO STRUCTURAL COMPONENTS ON THIS DOCUMENT. SEAL DOES NOT INCLUDE CONSTRUCTION MEANS, METHODS, TECHNIQUES, SEQUENCES, PROCEDURES OR SAFETY PRECAUTIONS. ANY DEVIATIONS OR DISCREPANCIES ON PLANS ARE TO BE BROUGHT TO THE IMMEDIATE ATTENTION OF SUMMIT ENGINEERING, LABORATORY & TESTING, INC. FAILURE TO DO SO WILL VOID SUMMIT LIABILITY.

STRUCTURAL ANALYSIS BASED ON 2018 NCRC.

FIRST FLOOR FRAMING PLAN

SCALE: 1/8"=1'

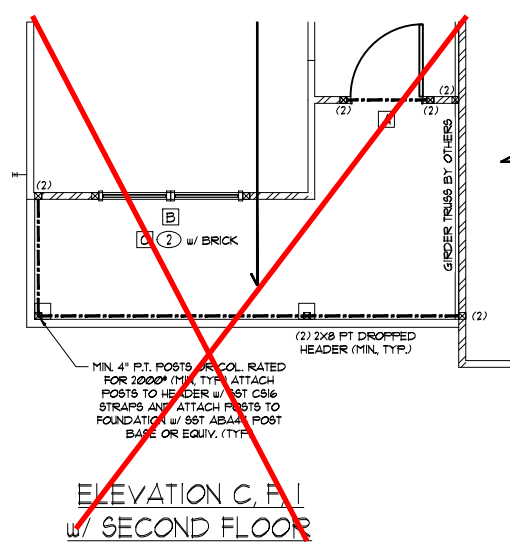
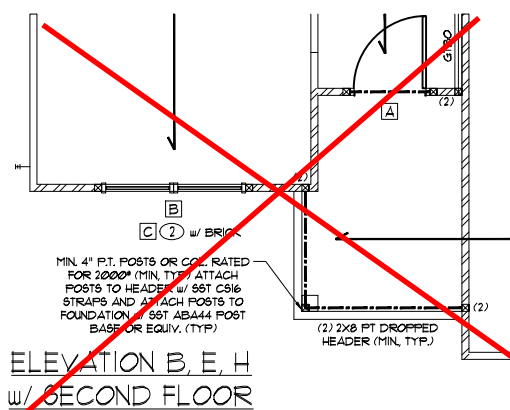
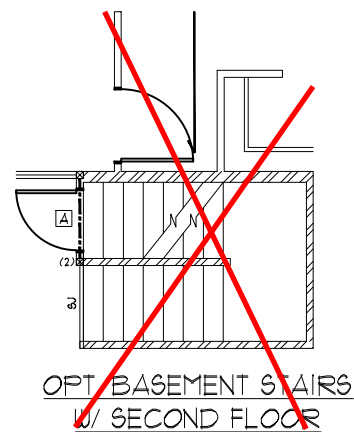
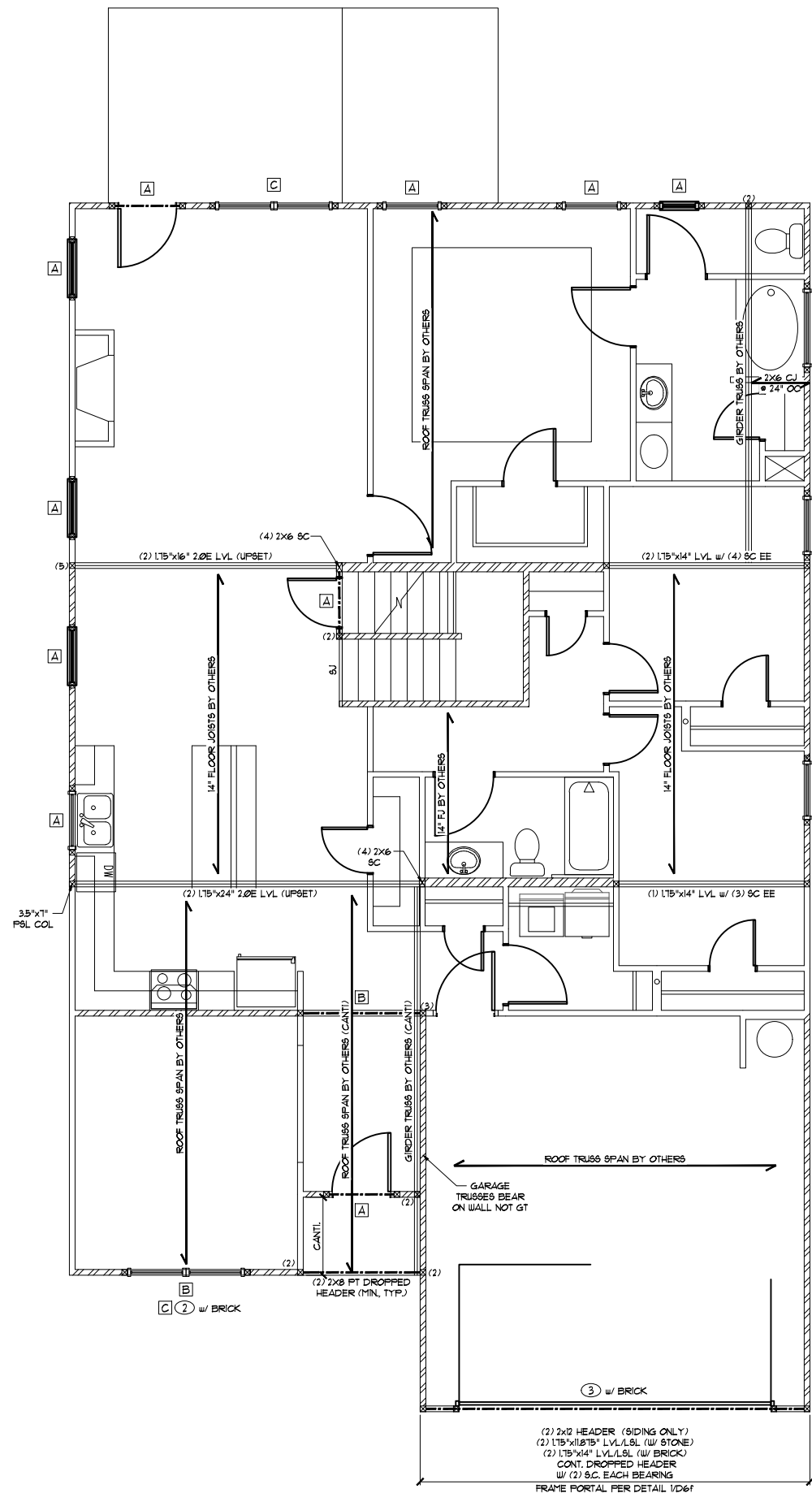

HEADER/BREAM SCHEDULE			
HEADER TAG	BEAM TAG	SIZE	JACKS (EACH END)
-	B1	(1) 14" FLOOR JOIST	(2)
-	B2	(2) 14" FLOOR JOIST	(2)
A	B3	(2) 2x6	(1)
B	B4	(2) 2x6	(2)
C	B5	(2) 2x6	(2)
D	B6	(2) 2x2	(2)
E	B7	(2) 9-1/4" LVL	(3)
F	B8	(2) 11-7/8" LVL	(3)
G	B9	(2) 14" LVL	(3)
H	B10	(2) 16" LVL	(3)
I	B11	(2) 18" LVL	(3)
J	B12	(2) 24" LVL	(4)
K	B13	(3) 9-1/4" LVL	(3)
L	B14	(3) 11-7/8" LVL	(3)
M	B16	(3) 14" LVL	(3)
N	B17	(3) 16" LVL	(3)
O	B18	(3) 18" LVL	(3)
P	B19	(3) 24" LVL	(4)

HEADER/BEAM SIZES SHOWN ON PLANS ARE MINIMUMS. GREATER HEADER/BEAM SIZES MAY BE USED FOR EASE OF CONSTRUCTION. ALL HEADERS TO BE DROPPED UNLESS NOTED OTHERWISE. ALL BEAMS TO BE FLUSH UNLESS NOTED OTHERWISE.

LINTEL SCHEDULE		
TAG	SIZE	OPENING SIZE
①	L3x3x1/4"	LESS THAN 6'-0"
②	L5x3x1/4"	6'-0" TO 10'-0"
③	L5x3-1/2"x5/16"	GREATER THAN 10'-0"
④	L5x3-1/2"x5/16" ROLLED OR EQUIV.	ALL ARCHED OPENINGS

SECURE LINTEL TO HEADER w/ (2) 1/2" DIAMETER LAG SCREWS STAGGERED @ 16" O.C. (TYP FOR ③)

ALL HEADERS WITH BRICK ABOVE: ① (UNO)

WALL STUD SCHEDULE

1ST & 2ND FLOOR LOAD BEARING WALLS:
2x6 STUDS @ 24" O.C. OR 2x4 STUDS @ 16" O.C.

1ST FLOOR LOAD BEARING WALLS SUPPORTING 2ND FLOOR + WALK-UP ATTIC:
2x6 STUDS @ 16" O.C. OR 2x4 STUDS @ 12" O.C.

BASEMENT LOAD BEARING WALLS:
2x6 STUDS @ 16" O.C. OR 2x4 STUDS @ 12" O.C.

NON-LOAD BEARING WALLS (ALL FLOORS):
2x4 STUDS @ 24" O.C.

TWO STORY WALLS:
2x4 STUDS @ 12" O.C. OR 2x6 STUDS @ 16" O.C. w/ 2x BRACKS @ 6'-0" O.C. VERTICALLY (AKA "BALLOON FRAMING")

OPENING WIDTH (FT)	KINGS (EACH END)	
	16" O.C.	24" O.C.
LESS THAN 3'-0"	(1)	(1)
3'-0" TO 4'-0"	(2)	(1)
4'-0" TO 8'-0"	(3)	(2)
8'-0" TO 12'-0"	(5)	(3)
12'-0" TO 16'-0"	(6)	(4)

KING STUD REQUIREMENTS ABOVE DO NOT APPLY TO PORTAL FRAMED OPENINGS

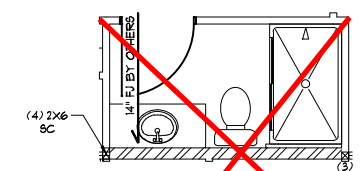

OPT. HALL BATH W/ SECOND FLOOR

BRIARWOOD Lot 6

SUMMIT
ENGINEERING • LABORATORY • TESTING
A Universal Engineering Sciences Company
2520 Whitehall Park Dr, Suite 250
Charlotte, NC 28273
Office: 704.504.1177
Fax: 704.504.1125
www.summit-companies.com

PROJECT
Telfair RH
First Floor Framing
CLIENT
Smith Douglas Homes - Raleigh
2520 Reliance Ave
Apex, NC 27539

CURRENT DRAWING
DATE: 11/15/2022
SCALE: 1/8"=1'-0"
PROJECT #: 3832.10041
DRAWN BY: EO
CHECKED BY: HKM

ORIGINAL DRAWING
DATE PROJECT #
09/24/2019 3832.303

REFER TO COVER SHEET FOR A COMPLETE LIST OF REVISIONS

SHEET
S3.2

SEE SHEET S3.2 FOR NOTES AND MORE INFORMATION

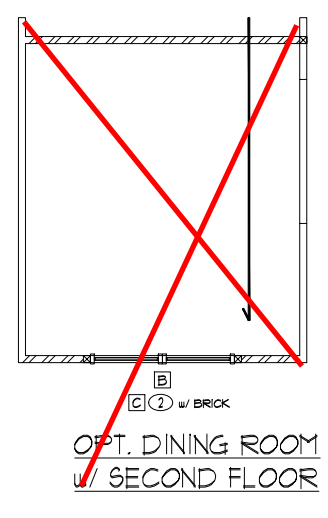
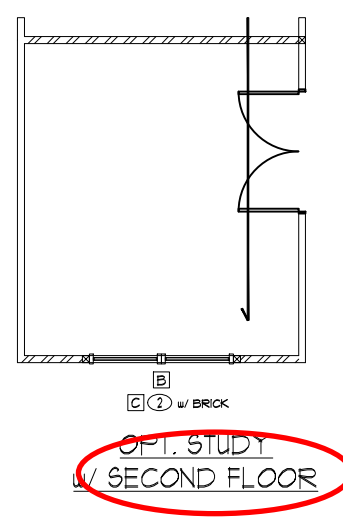
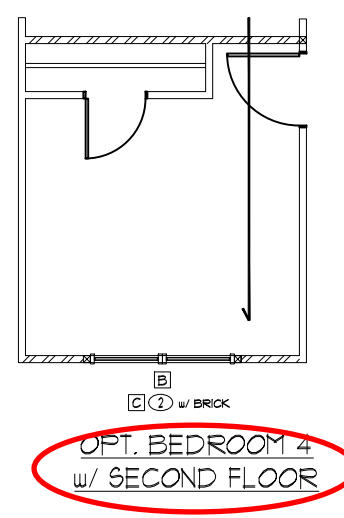
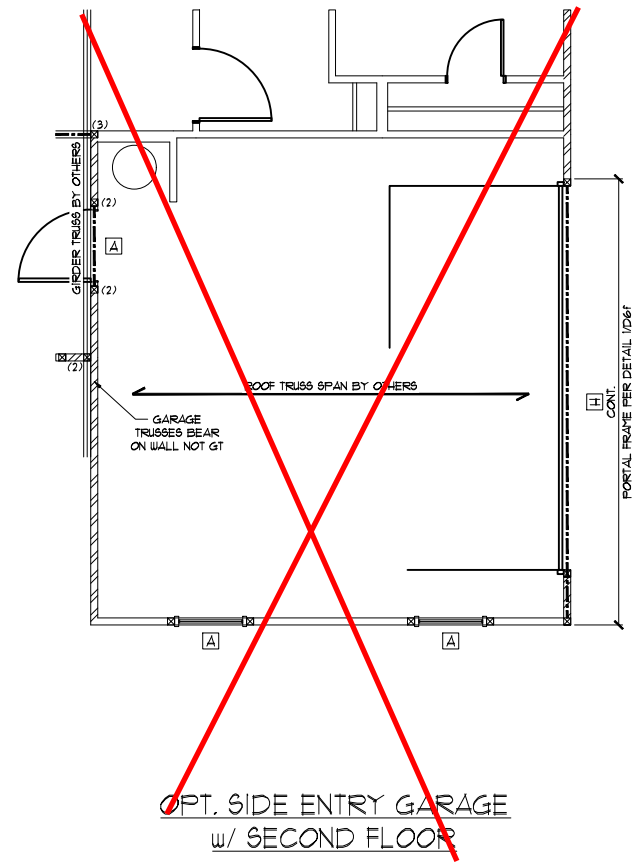
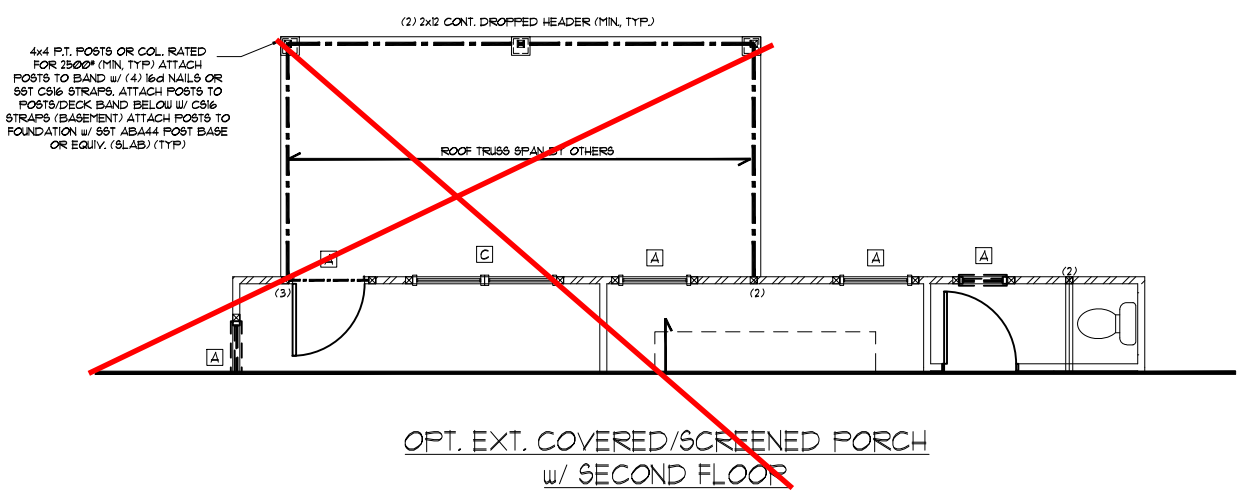
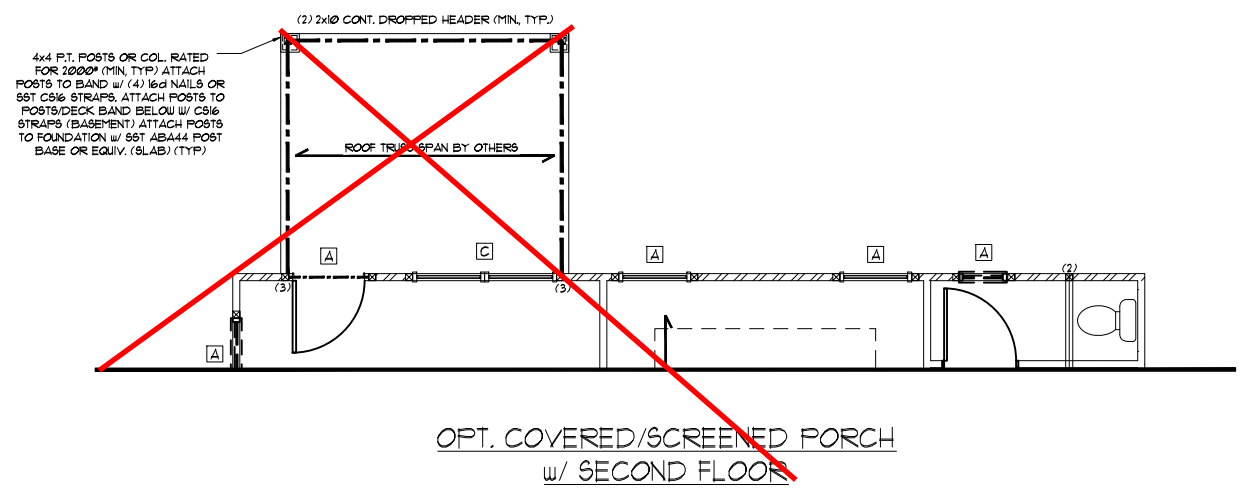

STRUCTURAL MEMBERS ONLY

ENGINEERING SEAL APPLIES ONLY TO STRUCTURAL COMPONENTS ON THIS DOCUMENT. SEAL DOES NOT INCLUDE CONSTRUCTION MEANS, METHODS, TECHNIQUES, SEQUENCES, PROCEDURES OR SAFETY PRECAUTIONS. ANY DEVIATIONS OR DISCREPANCIES ON PLANS ARE TO BE BROUGHT TO THE IMMEDIATE ATTENTION OF SUMMIT ENGINEERING, LABORATORY & TESTING, INC. FAILURE TO DO SO WILL VOID SUMMIT LIABILITY.

STRUCTURAL ANALYSIS BASED ON 2018 NCRC.

FIRST FLOOR FRAMING PLAN

SCALE: 1/8"=1'

BRIARWOOD
Lot 6

NORTH CAROLINA
PROFESSOR
SEAL
HENRY KUEHR-MCLAREN
ENGINEER
053883
11/21/2022

STRUCTURAL MEMBERS ONLY

SUMMIT
ENGINEERING • LABORATORY • TESTING
A Universal Engineering Sciences Company
2520 Whitehall Park Dr, Suite 250
Charlotte, NC 28273
Office: 704.504.1717
Fax: 704.504.1125
www.summit-companies.com

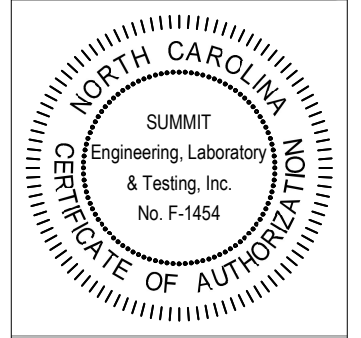

PROJECT
Telfair RH
First Floor Framing
CLIENT
Smith Douglas Homes - Raleigh
2520 Reliance Ave
Apex, NC 27539

CURRENT DRAWING
DATE: 11/15/2022
SCALE: 1/8"=1'-0"
PROJECT #: 3832.10041
DRAWN BY: EO
CHECKED BY: HKM

ORIGINAL DRAWING
DATE PROJECT #
09/24/2019 3832.303

REFER TO COVER SHEET FOR A COMPLETE LIST OF REVISIONS

SHEET
S3.3

HEADER/BEAM SCHEDULE			
HEADER TAG	BEAM TAG	SIZE	JACKS (EACH END)
-	B1	(1) 14" FLOOR JOIST	(2)
-	B2	(2) 14" FLOOR JOIST	(2)
A	B3	(2) 2x6	(1)
B	B4	(2) 2x6	(2)
C	B5	(2) 2x6	(2)
D	B6	(2) 2x2	(2)
E	B7	(2) 9-1/4" LVL	(3)
F	B8	(2) 11-1/8" LVL	(3)
G	B9	(2) 14" LVL	(3)
H	B10	(2) 16" LVL	(3)
I	B11	(2) 18" LVL	(3)
J	B12	(2) 24" LVL	(4)
K	B13	(3) 9-1/4" LVL	(3)
L	B14	(3) 11-1/8" LVL	(3)
M	B16	(3) 14" LVL	(3)
N	B17	(3) 16" LVL	(3)
O	B18	(3) 18" LVL	(3)
P	B19	(3) 24" LVL	(4)

HEADER/BEAM SIZES SHOWN ON PLANS ARE MINIMUMS. GREATER HEADER/BEAM SIZES MAY BE USED FOR EASE OF CONSTRUCTION. ALL HEADERS TO BE DROPPED UNLESS NOTED OTHERWISE. ALL BEAMS TO BE FLUSH UNLESS NOTED OTHERWISE.

LINTEL SCHEDULE		
TAG	SIZE	OPENING SIZE
①	L3x3x1/4"	LESS THAN 6'-0"
②	L5x3x1/4"	6'-0" TO 10'-0"
③	L5x3-1/2"x5/16"	GREATER THAN 10'-0"
④	L5x3-1/2"x5/16" ROLLED OR EQUIV.	ALL ARCHED OPENINGS

SECURE LINTEL TO HEADER w/ (2) 1/2" DIAMETER LAG SCREWS STAGGERED @ 16" O.C. (TYP FOR ③)

ALL HEADERS WITH BRICK ABOVE: ① (UNO)

WALL STUD SCHEDULE	
1ST & 2ND FLOOR LOAD BEARING WALLS	2x6 STUDS @ 24" O.C. OR 2x4 STUDS @ 16" O.C.
1ST FLOOR LOAD BEARING WALLS SUPPORTING 2ND FLOOR WALK-UP ATTIC	2x6 STUDS @ 16" O.C. OR 2x4 STUDS @ 12" O.C.
BASEMENT LOAD BEARING WALLS	2x6 STUDS @ 16" O.C. OR 2x4 STUDS @ 12" O.C.
NONLOAD BEARING WALLS (ALL FLOORS)	2x4 STUDS @ 24" O.C.
TWO STORY WALLS	2x4 STUDS @ 12" O.C. OR 2x6 STUDS @ 16" O.C. w/ 2X BRACING @ 6'-0" O.C. VERTICALLY (AKA "BALLOON FRAMING")

KING STUD REQUIREMENTS		
OPENING WIDTH (FT)	KINGS (EACH END)	
	16" O.C.	24" O.C.
LESS THAN 3'-0"	(1)	(1)
3'-0" TO 4'-0"	(2)	(1)
4'-0" TO 8'-0"	(3)	(2)
8'-0" TO 12'-0"	(5)	(3)
12'-0" TO 16'-0"	(6)	(4)

KING STUD REQUIREMENTS ABOVE DO NOT APPLY TO PORTAL FRAMED OPENINGS

THESE PLANS ARE DESIGNED IN ACCORDANCE WITH ARCHITECTURAL PLANS PROVIDED BY SMITH DOUGLAS HOMES COMPLETED/REVISED ON 8/20/2022. IT IS THE RESPONSIBILITY OF THE CLIENT TO NOTIFY SUMMIT ENGINEERING, LABORATORY & TESTING, INC. IF ANY CHANGES ARE MADE TO THE ARCHITECTURAL PLANS PRIOR TO CONSTRUCTION. SUMMIT ENGINEERING, LABORATORY & TESTING, INC. CANNOT GUARANTEE THE ADEQUACY OF THESE STRUCTURAL PLANS WHEN USED WITH ARCHITECTURAL PLANS DATED DIFFERENTLY THAN THE DATE LISTED ABOVE.

STRUCTURAL MEMBERS ONLY
 ENGINEERING SEAL APPLIES ONLY TO STRUCTURAL COMPONENTS ON THIS DOCUMENT. SEAL DOES NOT INCLUDE CONSTRUCTION MEANS, METHODS, TECHNIQUES, SEQUENCES, PROCEDURES OR SAFETY PRECAUTIONS. ANY DEVIATIONS OR DISCREPANCIES ON PLANS ARE TO BE BROUGHT TO THE IMMEDIATE ATTENTION OF SUMMIT ENGINEERING, LABORATORY & TESTING, INC. FAILURE TO DO SO WILL VOID SUMMIT LIABILITY.

STRUCTURAL ANALYSIS BASED ON 2018 NCRC.

SECOND FLOOR FRAMING PLAN
 SCALE: 1/8"=1'

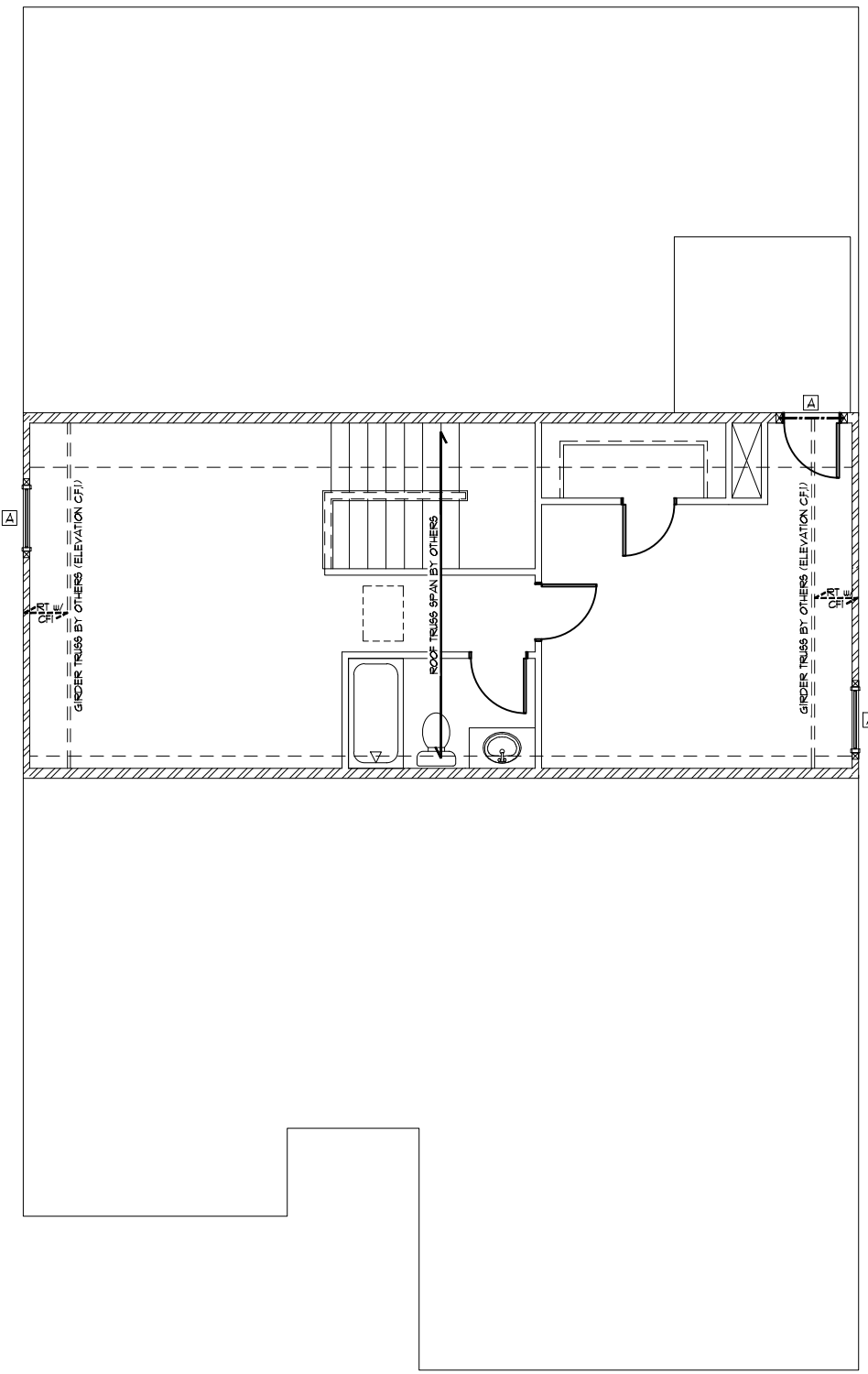

ALL ELEVATIONS

BRIARWOOD
 Lot 6

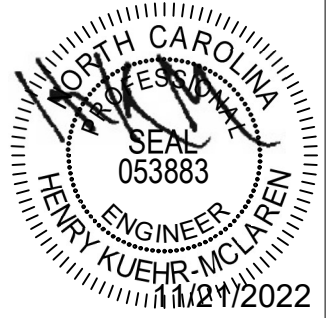

STRUCTURAL MEMBERS ONLY

SUMMIT
 ENGINEERING • LABORATORY • TESTING
 A Universal Engineering Sciences Company
 2520 Whitehall Park Dr, Suite 250
 Charlotte, NC 28273
 Office: 704.504.1717
 Fax: 704.504.1125
 www.summit-companies.com

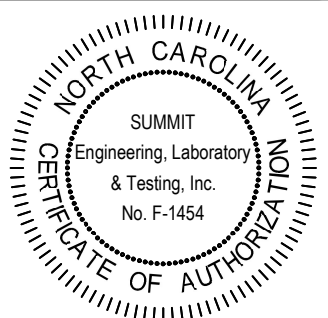

PROJECT
 Telfair RH
 Second Floor Framing
 CLIENT
 Smith Douglas Homes - Raleigh
 2520 Reliance Ave
 Apex, NC 27539

CURRENT DRAWING
 DATE: 11/15/2022
 SCALE: 1/8"=1'-0"
 PROJECT #: 3832.10041
 DRAWN BY: EO
 CHECKED BY: HKM

ORIGINAL DRAWING
 DATE PROJECT #
 09/24/2019 3832.303

REFER TO COVER SHEET FOR A COMPLETE LIST OF REVISIONS

SHEET
S4.0

TRUSS UPLIFT CONNECTOR SCHEDULE

MAX. UPLIFT	ROOF TO WALL	FLOOR TO FLOOR	FLOOR TO END
935 LBS	H2.5A	PER WALL SHEATHING & FASTENERS	
1070 LBS	(2) H2.5A	C516 (END + 13')	DTTZZ
1245 LBS	HT620	C516 (END + 13')	DTTZZ
1720 LBS	(2) HT620	(2) C516 (END + 13')	DTTZZ
2490 LBS	(2) HT520	(2) C516 (END + 13')	HTT4
2365 LBS	LGT3-9D525	(2) C516 (END + 13')	HTT4

1. ALL PRODUCTS LISTED ARE SIMPSON STRONG-TIE EQUIVALENT PRODUCTS MAY BE USED PER MANUFACTURER'S SPECIFICATIONS.
2. UPLIFT VALUES LISTED ARE FOR SFF 2 GRADE MEMBERS.
3. REFER TO TRUSS LAYOUT PER MANUF. FOR UPLIFT VALUES AND TRUSS TO TRUSS CONNECTIONS. CONNECTORS SPECIFIED BY TRUSS MANUFACTURER OVERRIDE THOSE LISTED ABOVE.
4. CONTACT SUMMIT FOR REQUIRED CONNECTORS WHEN LOADS EXCEED THOSE LISTED ABOVE.

NOTE: 1ST PLY OF ALL SHOWN GIRDER TRUSSES TO ALIGN WITH INSIDE FACE OF WALL (TYP, UNO)

NOTE: ROOF TRUSSES SHALL BE SPACED TO SUPPORT FALSE FRAMED DORMER WALLS (TYP, UNO)

NOTE: TRUSS UPLIFT LOADS SHALL BE DETERMINED PER TRUSS MANUFACTURER IN ACCORDANCE WITH SECTION R602.3.11.1 WALL SHEATHING AND FASTENERS HAVE BEEN DESIGNED TO RESIST THE WIND UPLIFT LOAD PATH IN ACCORDANCE WITH METHOD 3 OF SECTION R602.3.5 OF THE 2018 NCRC. REFER TO BRACED WALL PLANS FOR SHEATHING AND FASTENER REQUIREMENTS.

~~OPT. COVERED RATIO~~ ~~OPT. EXT. COVERED RATIO~~

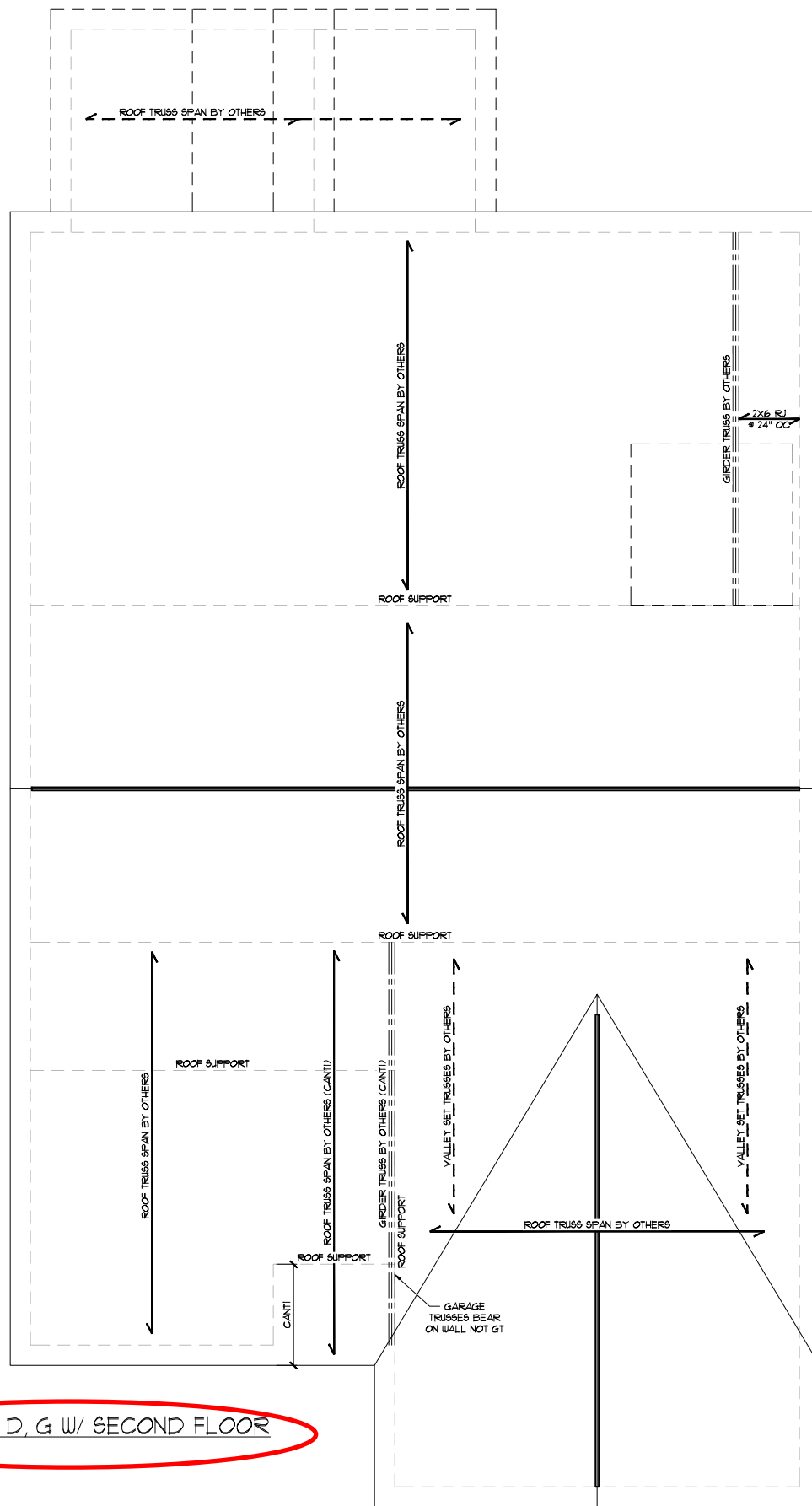

THESE PLANS ARE DESIGNED IN ACCORDANCE WITH ARCHITECTURAL PLANS PROVIDED BY SMITH DOUGLAS HOMES COMPLETED/REVISED ON 8/10/2022. IT IS THE RESPONSIBILITY OF THE CLIENT TO NOTIFY SUMMIT ENGINEERING, LABORATORY & TESTING, INC. IF ANY CHANGES ARE MADE TO THE ARCHITECTURAL PLANS PRIOR TO CONSTRUCTION. SUMMIT ENGINEERING, LABORATORY & TESTING, INC. CANNOT GUARANTEE THE ADEQUACY OF THESE STRUCTURAL PLANS WHEN USED WITH ARCHITECTURAL PLANS DATED DIFFERENTLY THAN THE DATE LISTED ABOVE.

STRUCTURAL MEMBERS ONLY
 ENGINEERING SEAL APPLIES ONLY TO STRUCTURAL COMPONENTS ON THIS DOCUMENT. SEAL DOES NOT INCLUDE CONSTRUCTION MEANS, METHODS, TECHNIQUES, SEQUENCES, PROCEDURES OR SAFETY PRECAUTIONS. ANY DEVIATIONS OR DISCREPANCIES ON PLANS ARE TO BE BROUGHT TO THE IMMEDIATE ATTENTION OF SUMMIT ENGINEERING, LABORATORY & TESTING, INC. FAILURE TO DO SO WILL VOID SUMMIT LIABILITY.

STRUCTURAL ANALYSIS BASED ON 2018 NCRC.

ROOF FRAMING PLAN
 SCALE: 1/8"=1'

BRIARWOOD
 Lot 6

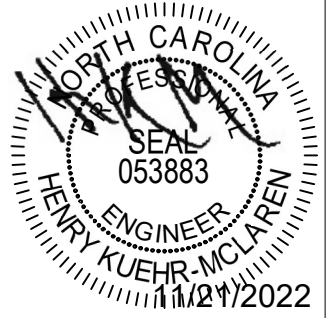

STRUCTURAL MEMBERS ONLY

SUMMIT
 ENGINEERING • LABORATORY • TESTING
 A Universal Engineering Sciences Company
 2520 Whitehall Park Dr, Suite 250
 Charlotte, NC 28273
 Office: 704.504.1717
 Fax: 704.504.1125
 www.summit-companies.com

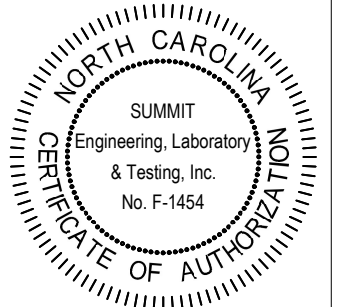

PROJECT
 Telfair RH
 Roof Framing Plan
 CLIENT
 Smith Douglas Homes - Raleigh
 2520 Reliance Ave
 Apex, NC 27539

CURRENT DRAWING
 DATE: 11/15/2022
 SCALE: 1/8"=1'-0"
 PROJECT #: 3832.10041
 DRAWN BY: EO
 CHECKED BY: HKM

ORIGINAL DRAWING
 DATE PROJECT #
 09/24/2019 3832.303

REFER TO COVER SHEET FOR A COMPLETE LIST OF REVISIONS

SHEET
S5.3

REQUIRED BRACED WALL PANEL CONNECTIONS				
METHOD	MATERIAL	MIN. THICKNESS	REQUIRED CONNECTION	
			# PANEL EDGES	# INTERMEDIATE SUPPORTS
CS-USP	WOOD STRUCTURAL PANEL	3/8"	6d COMMON NAILS* # 6" O.C.	6d COMMON NAILS* # 12" O.C.
GB	GYP-SUM BOARD	1/2"	5d COOLER NAILS** # 1" O.C.	5d COOLER NAILS** # 1" O.C.
USP	WOOD STRUCTURAL PANEL	3/8"	6d COMMON NAILS* # 6" O.C.	6d COMMON NAILS* # 12" O.C.
FF	WOOD STRUCTURAL PANEL	1/4"	PER FIGURE R6-02.10.6.4	PER FIGURE R6-02.10.6.4

*BASED ON 16" O.C. STUD SPACING **OR EQUIVALENT PER TABLE R102.3.5

- BRACED WALL NOTES:**
- WALLS SHALL BE DESIGNED IN ACCORDANCE WITH SECTION R6-02.10 FROM THE 2015 INTERNATIONAL RESIDENTIAL CODE AS ALLOWED PER SECTION R6-02.10 OF THE 2018 NC RESIDENTIAL CODE.
 - WALLS ARE DESIGNED FOR SEISMIC ZONES A-C AND MAXIMUM WIND SPEEDS OF 120 MPH.
 - BRACING MATERIALS, METHODS AND FASTENERS SHALL BE IN ACCORDANCE WITH IRC TABLE R6-02.10.4.
 - REFER TO ARCHITECTURAL PLAN FOR DOOR/WINDOW OPENING SIZES.
 - ALL BRACED WALL PANELS SHALL BE FULL WALL HEIGHT AND SHALL NOT EXCEED 10 FEET FOR ISOLATED PANEL METHOD AND 12 FEET FOR CONTINUOUS SHEATHING METHOD WITHOUT ADDITIONAL ENGINEERING CALCULATIONS.
 - MINIMUM PANEL LENGTH SHALL BE PER TABLE R6-02.10.5.
 - THE INTERIOR SIDE OF EXTERIOR WALLS AND BOTH SIDES OF INTERIOR WALLS SHALL BE SHEATHED CONTINUOUSLY WITH MINIMUM 1/2" GYP-SUM BOARD (UNO).
 - FOR CONTINUOUS SHEATHING METHOD, EXTERIOR WALLS SHALL BE SHEATHED ON ALL SHEATHABLE SURFACES INCLUDING INFILL AREAS BETWEEN BRACED WALL PANELS, ABOVE AND BELOW WALL OPENINGS, AND ON GABLE END WALLS.
 - FLOORS SHALL NOT BE CANTILEVERED MORE THAN 24" BEYOND THE FOUNDATION OR BEARING WALL BELOW WITHOUT ADDITIONAL ENGINEERING CALCULATIONS.
 - A BRACED WALL PANEL SHALL BEGIN WITHIN 10 FEET FROM EACH END OF A BRACED WALL LINE.
 - THE DISTANCE BETWEEN ADJACENT EDGES OF BRACED WALL PANELS ALONG A BRACED WALL LINE SHALL BE NO GREATER THAN 20 FEET.
 - ADQUATE CONTINUOUS LOAD PATHS FOR TRANSFER OF BRACING LOADS AND UPLIFT LOADS SHALL COMPLY WITH IRC SECTION R6-02.3.5.
 - MASONRY OR CONCRETE STEM WALLS WITH A LENGTH OF 48" OR LESS SUPPORTING A BRACED WALL PANEL SHALL BE DESIGNED IN ACCORDANCE WITH FIGURE R6-02.10.3.
 - BRACED WALL PANEL CONNECTIONS TO FLOOR/CEILING SHALL BE CONSTRUCTED IN ACCORDANCE WITH SECTION R6-02.10.8 (SEE SHEET D13 FROM DETAIL PACKAGE).
 - BRACED WALL PANEL CONNECTIONS TO ROOF SHALL BE CONSTRUCTED IN ACCORDANCE WITH SECTION R6-02.10.8.2 AND FIGURES R6-02.10.8.1(A)(7)(1,3).
 - CRIPPLE WALLS AND WALK OUT BASEMENT WALLS SHALL BE DESIGNED IN ACCORDANCE WITH SECTION R6-02.10.3.
 - PORTAL WALLS SHALL BE DESIGNED IN ACCORDANCE WITH FIGURE R6-02.10.6.4 (UNO).
 - ON SCHEMATIC, SHADED WALLS INDICATE BRACED WALL PANELS.
- ABBREVIATIONS:**
 GB = GYP-SUM BOARD USP = WOOD STRUCTURAL PANEL
 CS-XXX = CONT. SHEATHED ENG = ENGINEERED SOLUTION
 FF = PORTAL FRAME ENG-FF = ENGINEERED PORTAL FRAME

THESE PLANS ARE DESIGNED IN ACCORDANCE WITH ARCHITECTURAL PLANS PROVIDED BY SMITH DOUGLAS HOMES COMPLETED/REVISED ON 8/10/2022. IT IS THE RESPONSIBILITY OF THE CLIENT TO NOTIFY SUMMIT ENGINEERING LABORATORY & TESTING, INC. IF ANY CHANGES ARE MADE TO THE ARCHITECTURAL PLANS PRIOR TO CONSTRUCTION. SUMMIT ENGINEERING LABORATORY & TESTING, INC. CANNOT GUARANTEE THE ADEQUACY OF THESE STRUCTURAL PLANS WHEN USED WITH ARCHITECTURAL PLANS DATED DIFFERENTLY THAN THE DATE LISTED ABOVE.

FIRST FLOOR BRACING (FT)		
CONTINUOUS SHEATHING METHOD		
	REQUIRED	PROVIDED
BUIL 1-1	10.4	16.8
BUIL 1-2	10.4	11.9
BUIL 1-3	6.6	11.6
BUIL 1-A	7.4	41
BUIL 1-B	7.4	52.0

INSTALL ANY REQUIRED HOLDINGS PER SECTION R6-02.10.8 AND FIGURE R6-02.10.1 OF THE 2015 IRC

STRUCTURAL MEMBERS ONLY
 ENGINEERING SEAL APPLIES ONLY TO STRUCTURAL COMPONENTS ON THIS DOCUMENT. SEAL DOES NOT INCLUDE CONSTRUCTION MEANS, METHODS, TECHNIQUES, SEQUENCES, PROCEDURES OR SAFETY PRECAUTIONS. ANY DEVIATIONS OR DISCREPANCIES ON PLANS ARE TO BE BROUGHT TO THE IMMEDIATE ATTENTION OF SUMMIT ENGINEERING, LABORATORY & TESTING, INC. FAILURE TO DO SO WILL VOID SUMMIT ELT LIABILITY.

STRUCTURAL ANALYSIS BASED ON 2015 IRC.

FIRST FLOOR BRACING PLAN
 SCALE: 1/8"=1'

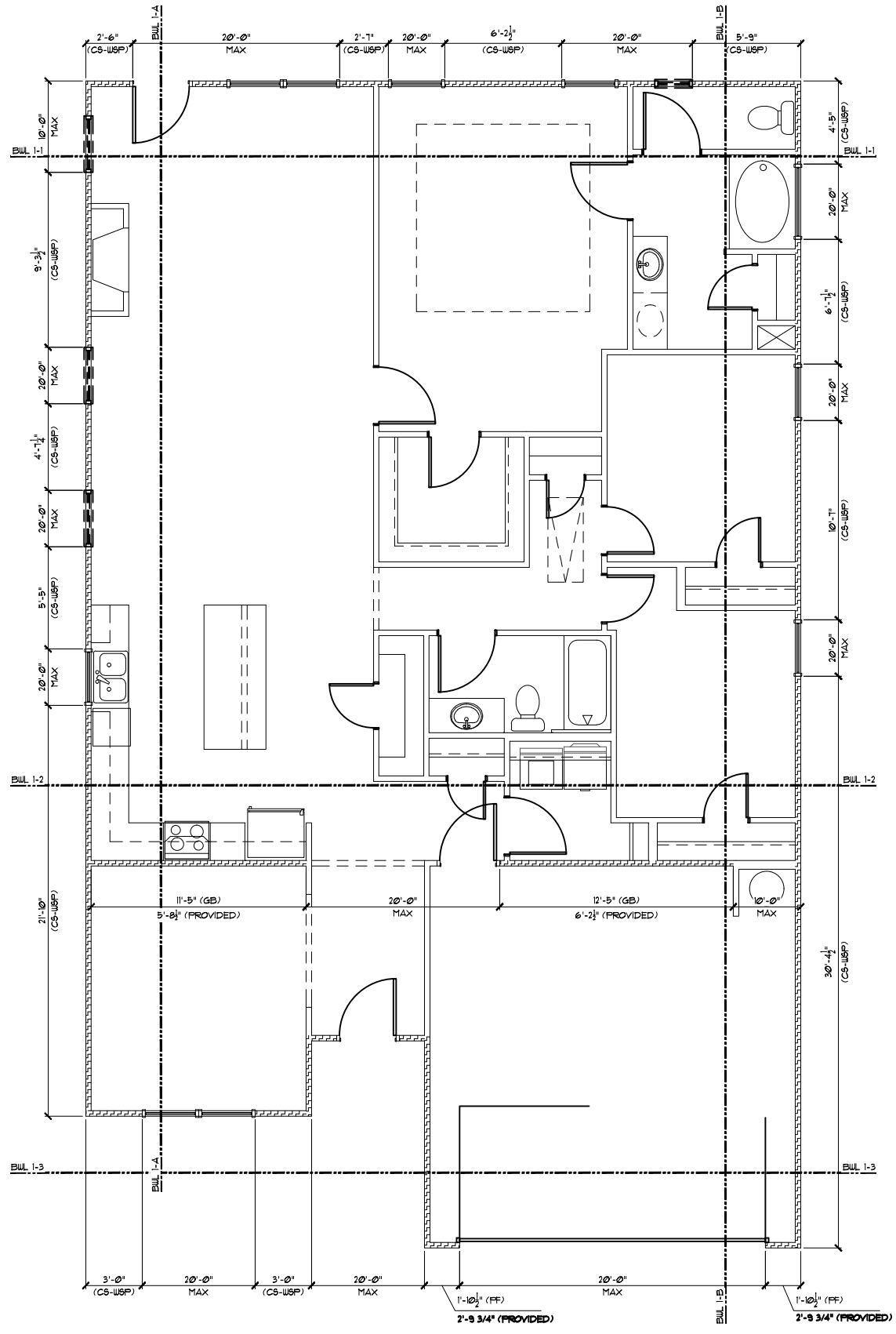

ALL ELEVATIONS

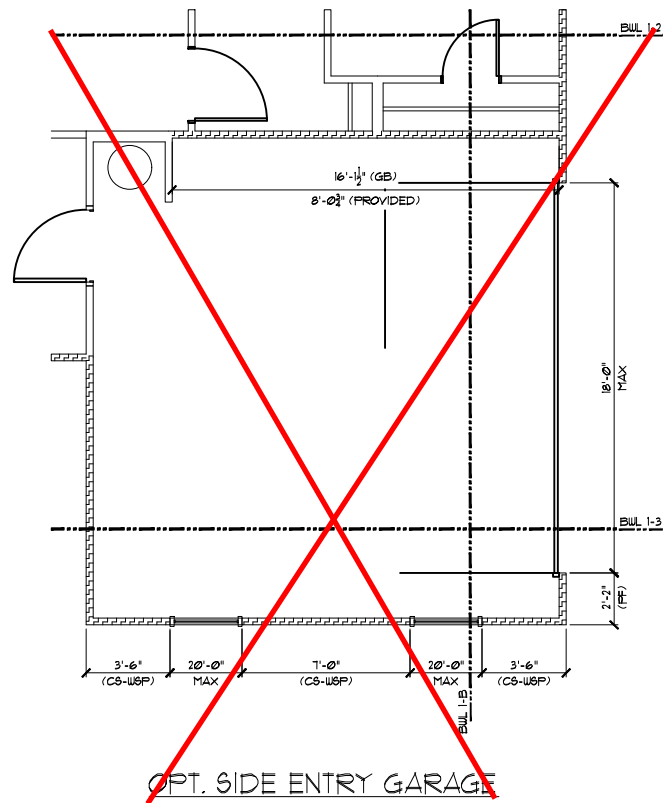

FIRST FLOOR BRACING (FT)		
CONTINUOUS SHEATHING METHOD		
	REQUIRED	PROVIDED
BUIL 1-1	10.4	16.8
BUIL 1-2	10.4	11.7
BUIL 1-3	6.6	20.0
BUIL 1-A	7.4	41
BUIL 1-B	7.4	36.3

BRIARWOOD
 Lot 6

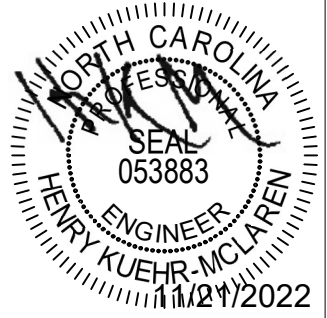

STRUCTURAL MEMBERS ONLY

SUMMIT
 ENGINEERING • LABORATORY • TESTING
 A Universal Engineering Sciences Company
 2520 Whitehall Park Dr, Suite 250
 Charlotte, NC 28273
 Office: 704.504.1717
 Fax: 704.504.1125
 www.summit-companies.com

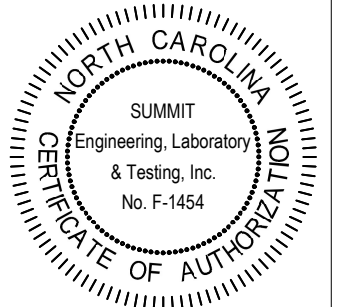

PROJECT
 Telfair RH
 First Floor Bracing
CLIENT
 Smith Douglas Homes - Raleigh
 2520 Reliance Ave
 Apex, NC 27539

CURRENT DRAWING
 DATE: 11/15/2022
 SCALE: 1/8"=1'-0"
 PROJECT #: 3832.10041
 DRAWN BY: EO
 CHECKED BY: HKM

ORIGINAL DRAWING
 DATE PROJECT #
 09/24/2019 3832.303

REFER TO COVER SHEET FOR A COMPLETE LIST OF REVISIONS

SHEET
 S7.0

REQUIRED BRACED WALL PANEL CONNECTIONS				
METHOD	MATERIAL	MIN. THICKNESS	REQUIRED CONNECTION	
			# PANEL EDGES	# INTERMEDIATE SUPPORTS
CS-WSP	WOOD STRUCTURAL PANEL	3/8"	6d COMMON NAILS* # 6" O.C.	6d COMMON NAILS* # 12" O.C.
GB	GYPSPUM BOARD	1/2"	5d COOLER NAILS** # 1" O.C.	5d COOLER NAILS** # 1" O.C.
WSP	WOOD STRUCTURAL PANEL	3/8"	6d COMMON NAILS* # 6" O.C.	6d COMMON NAILS* # 12" O.C.
FF	WOOD STRUCTURAL PANEL	1/4"	PER FIGURE R602.10.6.4	PER FIGURE R602.10.6.4

*BASED ON 16" O.C. STUD SPACING **OR EQUIVALENT PER TABLE R102.3.5

- BRACED WALL NOTES:**
- WALLS SHALL BE DESIGNED IN ACCORDANCE WITH SECTION R602.10 FROM THE 2018 INTERNATIONAL RESIDENTIAL CODE AS ALLOWED PER SECTION R602.10 OF THE 2018 NC RESIDENTIAL CODE.
 - WALLS ARE DESIGNED FOR SEISMIC ZONES A-C AND MAXIMUM WIND SPEEDS OF 130 MPH.
 - BRACING MATERIALS, METHODS AND FASTENERS SHALL BE IN ACCORDANCE WITH IRC TABLE R602.10.4.
 - REFER TO ARCHITECTURAL PLAN FOR DOOR/WINDOW OPENING SIZES.
 - ALL BRACED WALL PANELS SHALL BE FULL WALL HEIGHT AND SHALL NOT EXCEED 10 FEET FOR ISOLATED PANEL METHOD AND 12 FEET FOR CONTINUOUS SHEATHING METHOD WITHOUT ADDITIONAL ENGINEERING CALCULATIONS.
 - MINIMUM PANEL LENGTH SHALL BE PER TABLE R602.10.5.
 - THE INTERIOR SIDE OF EXTERIOR WALLS AND BOTH SIDES OF INTERIOR WALLS SHALL BE SHEATHED CONTINUOUSLY WITH MINIMUM 1/2" GYPSPUM BOARD (UNO).
 - FOR CONTINUOUS SHEATHING METHOD, EXTERIOR WALLS SHALL BE SHEATHED ON ALL SHEATHABLE SURFACES INCLUDING INFILL AREAS BETWEEN BRACED WALL PANELS, ABOVE AND BELOW WALL OPENINGS, AND ON GABLE END WALLS.
 - FLOORS SHALL NOT BE CANTILEVERED MORE THAN 24" BEYOND THE FOUNDATION OR BEARING WALL BELOW WITHOUT ADDITIONAL ENGINEERING CALCULATIONS.
 - A BRACED WALL PANEL SHALL BEGIN WITHIN 10 FEET FROM EACH END OF A BRACED WALL LINE.
 - THE DISTANCE BETWEEN ADJACENT EDGES OF BRACED WALL PANELS ALONG A BRACED WALL LINE SHALL BE NO GREATER THAN 20 FEET.
 - ADAPTED CONTINUOUS LOAD PATHS FOR TRANSFER OF BRACING LOADS AND UPLIFT LOADS SHALL COMPLY WITH IRC SECTION R602.3.5.
 - MASONRY OR CONCRETE STEM WALLS WITH A LENGTH OF 48' OR LESS SUPPORTING A BRACED WALL PANEL SHALL BE DESIGNED IN ACCORDANCE WITH FIGURE R602.10.3.
 - BRACED WALL PANEL CONNECTIONS TO FLOOR/CEILING SHALL BE CONSTRUCTED IN ACCORDANCE WITH SECTION R602.10.8 (SEE SHEET D13 FROM DETAIL PACKAGE).
 - BRACED WALL PANEL CONNECTIONS TO ROOF SHALL BE CONSTRUCTED IN ACCORDANCE WITH SECTION R602.10.8.2 AND FIGURES R602.10.8.1(1/2)/1.3.
 - CRIPPLE WALLS AND WALK OUT BASEMENT WALLS SHALL BE DESIGNED IN ACCORDANCE WITH SECTION R602.10.1.
 - PORTAL WALLS SHALL BE DESIGNED IN ACCORDANCE WITH FIGURE R602.10.6.4 (UNO).
 - ON SCHEMATIC, SHADED WALLS INDICATE BRACED WALL PANELS.
- 19) ABBREVIATIONS:
 GB = GYPSPUM BOARD WSP = WOOD STRUCTURAL PANEL
 CS-XXX = CONT. SHEATHED ENG = ENGINEERED SOLUTION
 FF = PORTAL FRAME ENG-FF = ENGINEERED PORTAL FRAME

THESE PLANS ARE DESIGNED IN ACCORDANCE WITH ARCHITECTURAL PLANS PROVIDED BY SMITH DOUGLAS HOMES COMPLETED/REVISED ON 8/10/2022. IT IS THE RESPONSIBILITY OF THE CLIENT TO NOTIFY SUMMIT ENGINEERING, LABORATORY & TESTING, INC. IF ANY CHANGES ARE MADE TO THE ARCHITECTURAL PLANS PRIOR TO CONSTRUCTION. SUMMIT ENGINEERING, LABORATORY & TESTING, INC. CANNOT GUARANTEE THE ADEQUACY OF THESE STRUCTURAL PLANS WHEN USED WITH ARCHITECTURAL PLANS DATED DIFFERENTLY THAN THE DATE LISTED ABOVE.

FIRST FLOOR BRACING (FT)		
	CONTINUOUS SHEATHING METHOD	
	REQUIRED	PROVIDED
BUIL 1-1	10.4	16.8
BUIL 1-2	10.4	11.9
BUIL 1-3	6.6	11.6
BUIL 1-A	7.4	16.8
BUIL 1-B	7.4	11.2

INSTALL ANY REQUIRED HOLDINGS PER SECTION R602.10.8 AND FIGURE R602.10.1 OF THE 2018 IRC

STRUCTURAL MEMBERS ONLY
 ENGINEERING SEAL APPLIES ONLY TO STRUCTURAL COMPONENTS ON THIS DOCUMENT. SEAL DOES NOT INCLUDE CONSTRUCTION MEANS, METHODS, TECHNIQUES, SEQUENCES, PROCEDURES OR SAFETY PRECAUTIONS. ANY DEVIATIONS OR DISCREPANCIES ON PLANS ARE TO BE BROUGHT TO THE IMMEDIATE ATTENTION OF SUMMIT ENGINEERING, LABORATORY & TESTING, INC. FAILURE TO DO SO WILL VOID SUMMIT LIABILITY.

STRUCTURAL ANALYSIS BASED ON 2018 NCRC.

FIRST FLOOR BRACING PLAN
 SCALE: 1/8"=1'

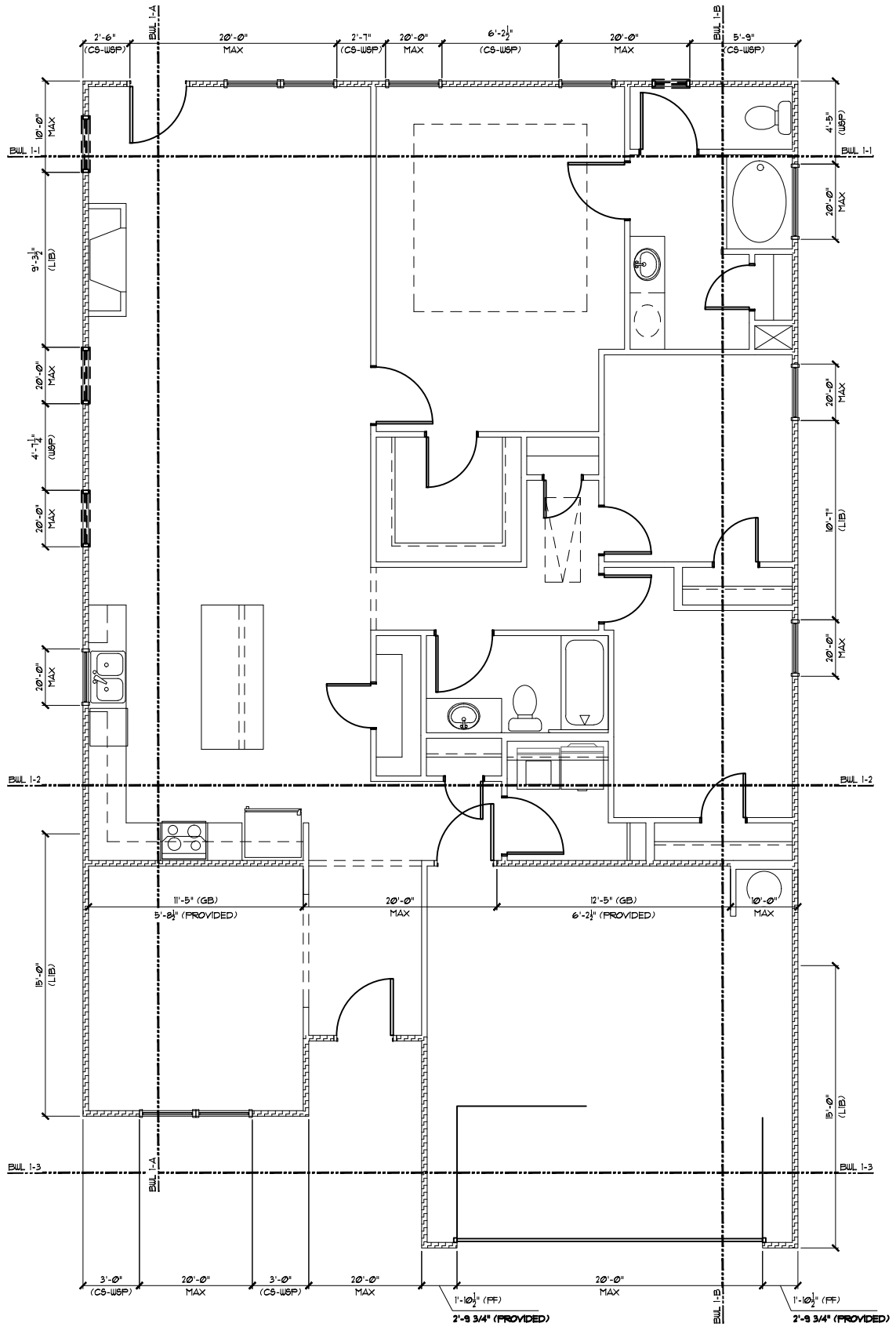
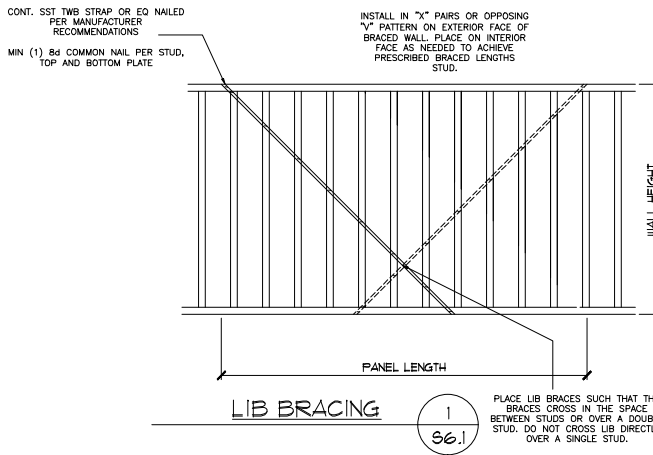

ALL ELEVATIONS
 BRACING OPTION 2

SEE SHEET S7.0 FOR NOTES AND MORE INFORMATION

BRIARWOOD
 Lot 6

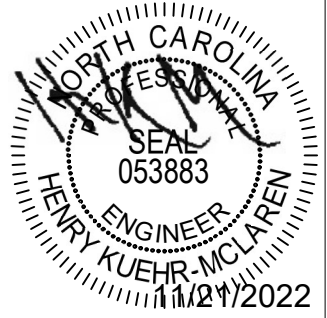

STRUCTURAL MEMBERS ONLY

SUMMIT
 ENGINEERING • LABORATORY • TESTING
 A Universal Engineering Sciences Company
 2520 Whitehall Park Dr, Suite 250
 Charlotte, NC 28273
 Office: 704.504.1717
 Fax: 704.504.1125
 www.summit-companies.com

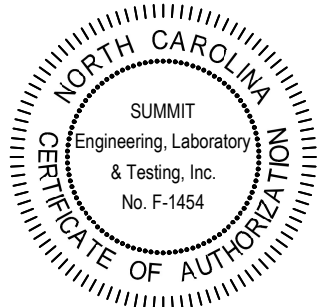

PROJECT
 Telfair RH
 First Floor Bracing
 CLIENT
 Smith Douglas Homes - Raleigh
 2520 Reliance Ave
 Apex, NC 27539

CURRENT DRAWING
 DATE: 11/15/2022
 SCALE: 1/8"=1'-0"
 PROJECT #: 3832.10041
 DRAWN BY: EO
 CHECKED BY: HKM

ORIGINAL DRAWING
 DATE PROJECT #
 09/24/2019 3832.303

REFER TO COVER SHEET FOR A COMPLETE LIST OF REVISIONS

SHEET
S7.1

GENERAL STRUCTURAL NOTES:

- The design professional whose seal appears on these drawings is the structural engineer of record (SER) for this project. The SER bears the responsibility of the primary structural elements and the performance of this structure. No other party may revise, alter, or delete any structural aspects of these construction documents without written permission of SUMMIT Engineering, Laboratory & Testing, P.C. (SUMMIT) or the SER. For the purposes of these construction documents the SER and SUMMIT shall be considered the same entity.
- The structure is only stable in its completed form. The contractor shall provide all required temporary bracing during construction to stabilize the structure.
- The SER is not responsible for construction sequences, methods, or techniques in connection with the construction of this structure. The SER will not be held responsible for the contractor's failure to conform to the contract documents, should any non-conformities occur.
- Any structural elements or details not fully developed on the construction drawings shall be completed under the direction of a licensed professional engineer. These shop drawings shall be submitted to SUMMIT for review before any construction begins. The shop drawings will be reviewed for overall compliance as it relates to the structural design of this project. Verification of the shop drawings for dimensions, or for actual field conditions, is not the responsibility of the SER or SUMMIT.
- Verification of assumed field conditions is not the responsibility of the SER. The contractor shall verify the field conditions for accuracy and report any discrepancies to SUMMIT before construction begins.
- The SER is not responsible for any secondary structural elements or non-structural elements, except for the elements specifically noted on the structural drawings.
- This structure and all construction shall conform to all applicable sections of the international residential code.
- This structure and all construction shall conform to all applicable sections of the 2018 North Carolina Residential Code (NCRC) and any local codes or restrictions

FOUNDATIONS:

- Foundations shall be constructed in accordance with chapter 4 of the 2018 NC Residential Building Code (Special consideration shall be given to Chapter 45 in wind zones above 130mph)
- Footing sizes based on a presumptive soil bearing capacity of 2000 PSF. Contractor is solely responsible for verifying the suitability of the site soil conditions at the time of construction
- Maximum depth of unbalanced fill against masonry walls to be as specified in section R404.1 of the 2018 NCRC
- The structural engineer has not performed a subsurface investigation. Verification of this assumed value is the responsibility of the owner or the contractor. Should any adverse soil condition be encountered the SER must be contacted before proceeding.
- The bottom of all footings shall extend below the frost line for the region in which the structure is to be constructed. However, the bottom of all footings shall be a minimum of 12" below grade.
- Any fill shall be placed under the direction or recommendation of a licensed professional engineer. The resulting soil shall be compacted to a minimum of 95% maximum dry density.
- Excavations of footings shall be lined temporarily with a 6 mil polyethylene membrane if placement of concrete does not occur within 24 hours of excavation.
- No concrete shall be placed against any subgrade containing water, ice, frost, or loose material.
- Each crawl space pier shall bear in the middle third of its respective footing and each girder shall bearing in the middle third of the piers. Pilasters to be bonded to perimeter foundation wall
- Crawl spaced to be graded level and clear of all debris
- Provide foundation waterproofing and drain with positive slope to outlet as required by site conditions
- Energy efficiency compliance and insulation of the structure to be in accordance with chapter 11 of the 2018 NCRC

CONCRETE:

- Concrete shall have a normal weight aggregate and a minimum compressive strength (f'c) at 28 days of 3000 psi, unless otherwise noted on the plan.
- Concrete shall be proportioned, mixed, and placed in accordance with the latest editions of ACI 318: "Building Code Requirements for Reinforced Concrete" and ACI 301: "Specifications for Structural Concrete for Buildings".
- Air entrained concrete must be used for all structural elements exposed to freeze/thaw cycles and deicing chemicals. Air entrainment amounts (in percent) shall be within -1% to +2% of target values as follows:
 - Footings: 5%
 - Exterior Slabs: 5%
- No admixtures shall be added to any structural concrete without written permission of the SER
- Concrete slabs-on-grade shall be constructed in accordance with ACI 302.1R-96: "Guide for Concrete Slab and Slab Construction".
- The concrete slab-on-grade has been designed using a subgrade modulus of k=250 pci and a design loading of 200 psf. The SER is not responsible for differential settlement, slab cracking or other future defects resulting from unreported conditions not in accordance with the above assumptions.
- Control or saw cut joints shall be spaced in interior slabs-on-grade at a maximum of 15'-0" O.C. and in exterior slabs-on-grade at a maximum of 10'-0" unless otherwise noted.
- Control or saw cut joints shall be produced using conventional process within 4 to 12 hours after the slab has been finished
- Reinforcing steel may not extend through a control joint. Reinforcing steel may extend through a saw cut joint.
- All welded wire fabric (W.W.F.) for concrete slabs-on-grade shall be placed at mid-depth of slab. The W.W.F. shall be securely supported during the concrete pour. Fibermesh may be used in lieu of W.W.F.

CONCRETE REINFORCEMENT:

- Fibrous concrete reinforcement, or fibermesh, specified in concrete slabs-on-grade may be used for control of cracking due to shrinkage and thermal expansion/contraction, lowered water migration, an increase in impact capacity, increased abrasion resistance, and residual strength.
- Fibermesh reinforcing to be 100% virgin polypropylene fibers containing no reprocessed olefin materials and specifically manufactured for use as concrete secondary reinforcement.
- Application of fibermesh per cubic yard of concrete shall equal a minimum of 0.1% by volume (1.5 pounds per cubic yard)
- Fibermesh shall comply with ASTM C1116, any local building code requirements, and shall meet or exceed the current industry standard.
- Steel Reinforcing bars shall be new billet steel conforming to ASTM A615, grade 60.
- Detailing, fabrication, and placement of reinforcing steel shall be in accordance with the latest edition of ACI 315: "Manual of Standard Practice for Detailing Concrete Structures"
- Horizontal footing and wall reinforcement shall be continuous and shall have 90° bends, or corner bars with the same size/spacing as the horizontal reinforcement with a class B tension splice.
- Lap reinforcement as required, a minimum of 40 bar diameters for tension or compression unless otherwise noted. Splices in masonry shall be a minimum of 48 bar diameters.
- Where reinforcing dowels are required, they shall be equivalent in size and spacing to the vertical reinforcement. The dowel shall extend 48 bar diameters vertically and 20 bar diameters into the footing.
- Where reinforcing steel is required vertically, dowels shall be provided unless otherwise noted.

WOOD FRAMING:

- Solid sawn wood framing members shall conform to the specifications listed in the latest edition of the "National Design Specification for Wood Construction" (NDS). Unless otherwise noted, all wood framing members are designed to be Spruce-Pine-Fir (SPF) #2.
- LVL or PSL engineered wood shall have the following minimum design values:
 - E = 1,900,000 psi
 - Fb = 2600 psi
 - Fv = 285 psi
 - Fc = 700 psi
- Wood in contact with concrete, masonry, or earth shall be pressure treated in accordance with AWPA standard C-15. All other moisture exposed wood shall be treated in accordance with AWPA standard C-2
- Nails shall be common wire nails unless otherwise noted.
- Lag screws shall conform to ANSI/ASME standard B18.2.1-1981. Lead holes for lag screws shall be in accordance with NDS specifications.
- All beams shall have full bearing on supporting framing members unless otherwise noted.
- Exterior and load bearing stud walls are to be 2x4 SPF#2 @16" O.C. unless otherwise noted. Studs shall be continuous from the sole plate to the double top plate. Studs shall only be discontinuous at headers for window/door openings. A minimum of one king stud shall be placed at each end of the header. King studs shall be continuous.
- Individual studs forming a column shall be attached with one 10d nail @6" O.C. staggered. The stud column shall be continuous to the foundation or beam. The column shall be fully blocked at all floor levels to ensure proper load transfer.
- Multi-ply beams shall have each ply attached with (3)10d nails @ 24" O.C.
- Fitch beams and four and five ply beams shall be bolted together with (2) rows of 1/2" dia. through bolts staggered @24" O.C. w/ 2" edge distance and (2) bolts located at 6" from each end, unless noted otherwise.

WOOD TRUSSES:

- The wood truss manufacturer/fabricator is responsible for the design of the wood trusses. Submit sealed shop drawings and supporting calculations to the SER for review prior to fabrication. The SER shall have a minimum of five (5) days for review. The review by the SER shall review for overall compliance with the design documents. The SER shall assume no responsibility for the correctness for the structural design for the wood trusses.
- The wood trusses shall be designed for all required loadings as specified in the local building code, the ASCE Standard "Minimum Design Loads for Buildings and Other Structures." (ASCE 7-10), and the loading requirements shown on these specifications. The truss drawings shall be coordinated with all other construction documents and provisions provided for loads shown on these drawings including but not limited to HVAC equipment, piping, and architectural fixtures attached to the trusses.
- The trusses shall be designed, fabricated, and erected in accordance with the latest edition of the "National Design Specification for Wood Construction." (NDS) and "Design Specification for Metal Plate Connected Wood Trusses."
- The truss manufacturer shall provide adequate bracing information in accordance with "Commentary and Recommendations for Handling, Installing, and Bracing Metal Plate Connected Wood Trusses" (HIB-91). This bracing, both temporary and permanent, shall be shown on the shop drawings. Also, the shop drawings shall show the required attachments for the trusses.
- Any chords or truss webs shown on these drawings have been shown as a reference only. The final design of the trusses shall be per the manufacturer.

WOOD STRUCTURAL PANELS:

- Fabrication and placement of structural wood sheathing shall be in accordance with the APA Design/Construction Guide "Residential and Commercial," and all other applicable APA standards.
- All structurally required wood sheathing shall bear the mark of the APA.
- Wood wall sheathing shall comply with the requirements of local building codes for the appropriate state as indicated on these drawings. Refer to wall bracing notes in plan set for more information. Sheathing shall be applied with the long direction perpendicular to framing, unless noted otherwise.
- Roof sheathing shall be APA rated sheathing exposure 1 or 2. Roof sheathing shall be continuous over two supports and attached to its supporting roof framing with (1)-8d CC nail at 6"o/c at panel edges and at 12"o/c in panel field unless otherwise noted on the plans. Sheathing shall be applied with the long direction perpendicular to framing. Sheathing shall have a span rating consistent with the framing spacing. Use suitable edge support by use of plywood clips or lumber blocking unless otherwise noted. Panel end joints shall occur over framing. Apply building paper over the sheathing as required by the state Building Code.
- Wood floor sheathing shall be APA rated sheathing exposure 1 or 2. Attach sheathing to its supporting framing with (1)-8d CC ringshank nail at 6"o/c at panel edges and at 12"o/c in panel field unless otherwise noted on the plans. Sheathing shall be applied perpendicular to framing. Sheathing shall have a span rating consistent with the framing spacing. Use suitable edge support by use of T&G plywood or lumber blocking unless otherwise noted. Panel end joints shall occur over framing. Apply building paper over the sheathing as required by the state Building Code.
- Sheathing shall have a 1/8" gap at panel ends and edges as recommended in accordance with the APA.

STRUCTURAL FIBERBOARD PANELS:

- Fabrication and placement of structural fiberboard sheathing shall be in accordance with the applicable AFA standards.
- Fiberboard wall sheathing shall comply with the requirements of local building codes for the appropriate state as indicated on these drawings. Refer to wall bracing notes in plan set for more information.
- Sheathing shall have a 1/8" gap at panel ends and edges are recommended in accordance with the AFA.

EXTERIOR WOOD FRAMED DECKS:

- Decks are to be framed in accordance with local building codes and as referenced on the structural plans, either through code references or construction details.

STRUCTURAL STEEL:

- Structural steel shall be fabricated and erected in accordance with the American Institute of Steel Construction "Code of Standard Practice for Steel Buildings and Bridges" and of the manual of Steel Construction "Load Resistance Factor Design" latest editions.
- All steel shall have a minimum yield stress (Fy) of 36 ksi unless otherwise noted.
- Welding shall conform to the latest edition of the American Welding Society's Structural Welding Code AWS D1.1. Electrodes for shop and field welding shall be class E70XX. All welding shall be performed by a certified welder per the above standards.

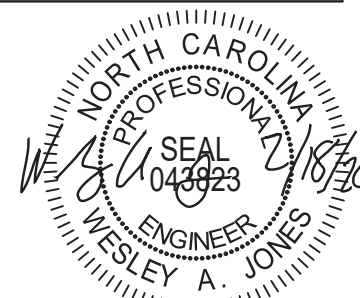

STRUCTURAL MEMBERS ONLY

SUMMIT
ENGINEERING LABORATORY TESTING
3070 HAMMOND BUSINESS PLACE,
SUITE 171, RALEIGH, NC 27603
OFFICE: 919.380.9991
FAX: 919.380.9993
WWW.SUMMIT-COMPANIES.COM

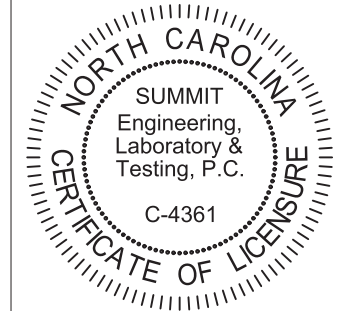

PROJECT
Standard Details
Notes and Specifications
CLIENT
Smith Douglas Homes
110 Village Trail, Suite 215
Woodstock, GA 30188

CURRENT DRAWING

DATE: 2/18/20
SCALE: NTS
PROJECT #: 3832
DRAWN BY: LBV
CHECKED BY: WAJ

ORIGINAL DRAWING

NO.	DATE	PROJECT #
0	1/7/16	3832

REFER TO COVER SHEET FOR A COMPLETE LIST OF REVISIONS

SHEET

CS2

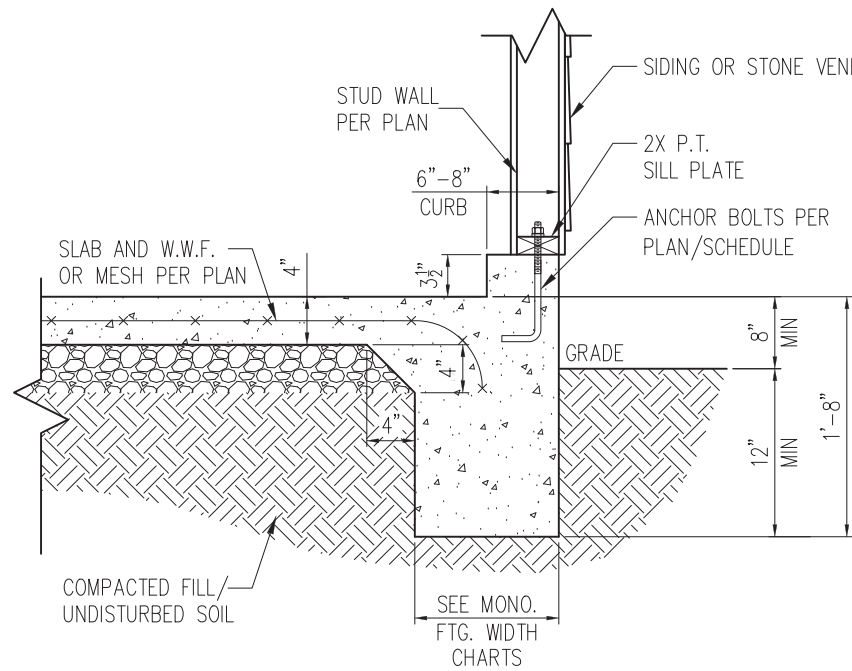

STANDARD - SIDING/STONE

1 TYP. GARAGE CURB DETAIL
D1m 3/4" = 1'-0"

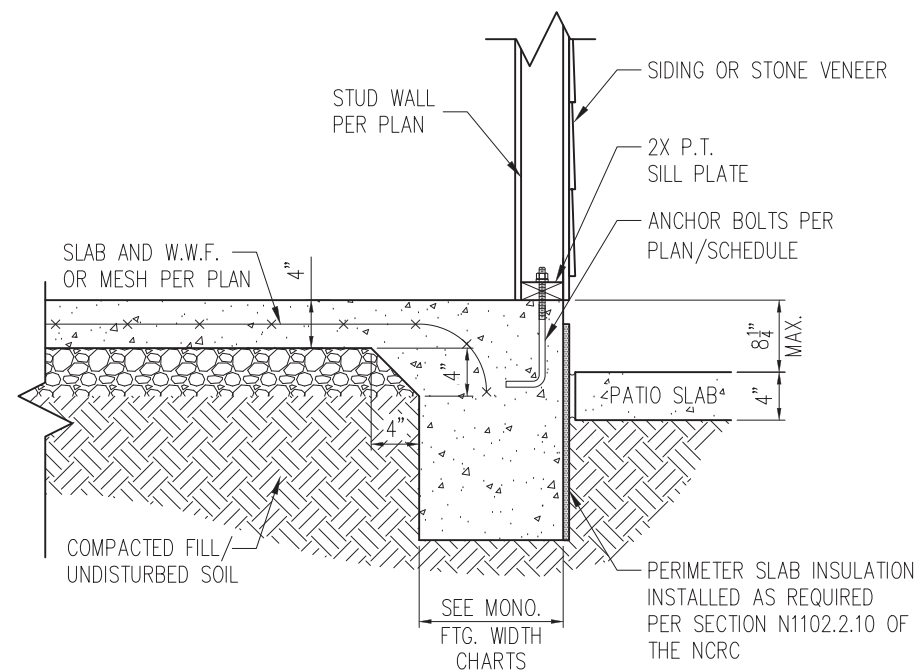

STANDARD - SIDING/STONE

2 PATIO SLAB DETAIL
D1m 3/4" = 1'-0"

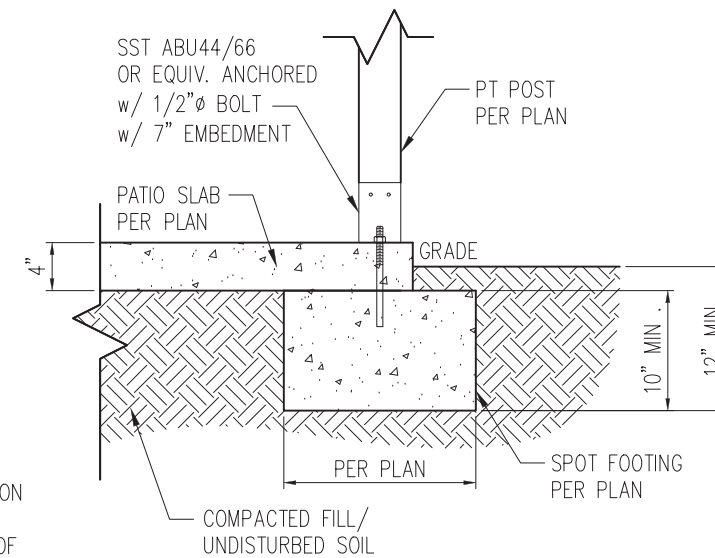

2A COVERED PATIO DETAIL
D1m 3/4" = 1'-0"

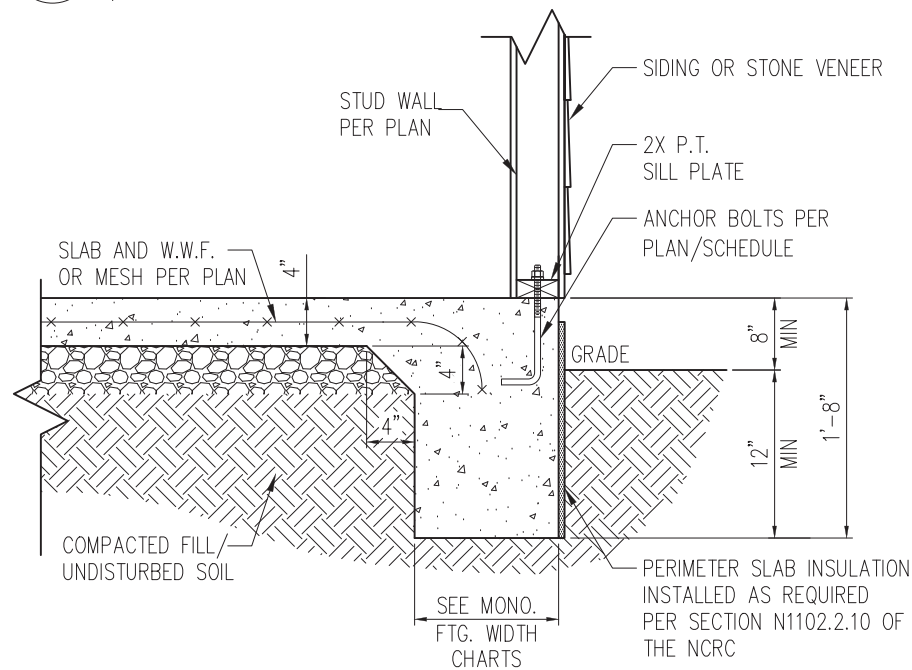

STANDARD - SIDING/STONE

3 TYP. SLAB DETAIL
D1m 3/4" = 1'-0"

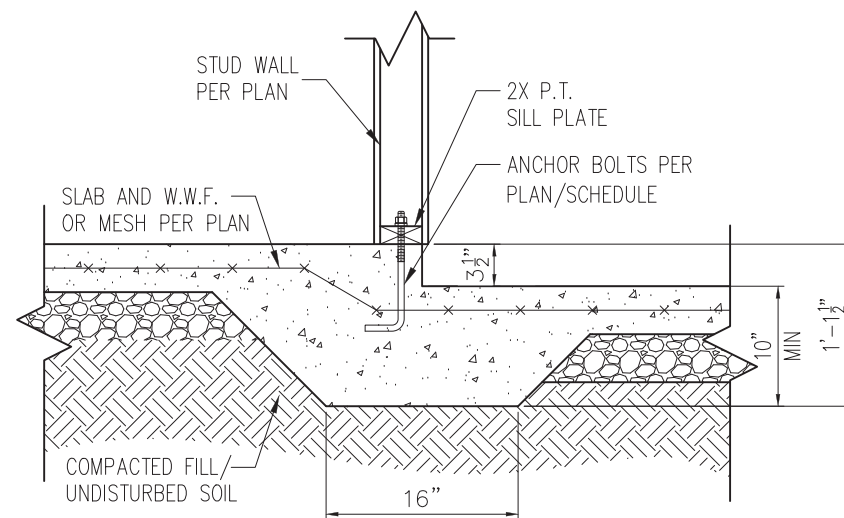

4 STEP IN GARAGE
D1m 3/4" = 1'-0"

WALL ANCHOR SCHEDULE

TYPE OF ANCHOR	MIN. CONC. EMBEDMENT	SPACING EMBEDMENT	INTERIOR WALL	EXTERIOR WALL
1/2" Ø A307 BOLTS w/ STD. 90° BEND	7"	6'-0"	YES	YES
SST - MAS	4"	5'-0"	NO	YES
HILTI KWIK BOLT KBI 1/2-2-3/4	2-1/4"	6'-0"	YES	NO
1/2" Ø HILTI THREADED ROD w/ HIT HY150 ADHESIVE	7"	6'-0"	YES	YES

NOTE: INSTALL ALL ANCHORS 12" MAX. FROM ALL BOTTOM PLATE ENDS AND JOINTS.

MONOLITHIC FOOTING WIDTH

# OF STORIES	WIDTH BASED ON SOIL BEARING CAPACITY		
	1500 PSF	2000 PSF	2500 PSF
1 STORY - STD.	16"	16"	16"
1 STORY - BRICK VENEER	21"	21"	21"
2 STORY - STD.	20"	16"	16"
2 STORY - BRICK VENEER	25"	21"	21"

*5" BRICK LEDGE HAS BEEN ADDED TO THE MONOLITHIC FOOTING WIDTH FOR BRICK SUPPORT

- NOTES:
- REFER TO GENERAL NOTES & SPECIFICATIONS ON SHEET CS2 FOR ADDITIONAL INFORMATION.
 - PROVIDE 6 MIL VAPOR BARRIER UNDER ALL SLABS-ON-GRADE.
 - SEE ARCH. DWGS. FOR ALL TOP OF THE SLAB ELEVATIONS, SLOPES AND DEPRESSIONS.

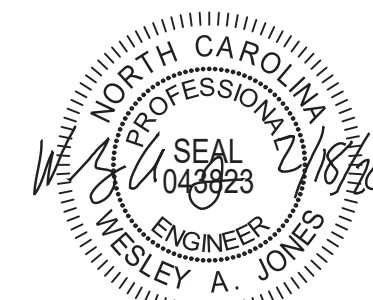

STRUCTURAL MEMBERS ONLY

SUMMIT
ENGINEERING LABORATORY TESTING
3070 HAMMOND BUSINESS PLACE,
SUITE 171, RALEIGH, NC 27603
OFFICE: 919.380.9991
FAX: 919.380.9993
WWW.SUMMIT-COMPANIES.COM

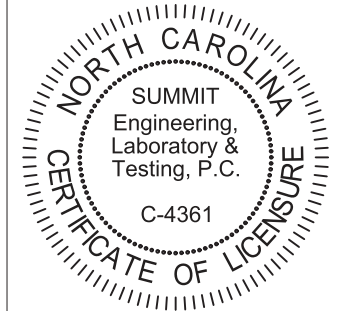

PROJECT
Standard Details
Monolithic Slab Details
CLIENT
Smith Douglas Homes
110 Village Trail, Suite 215
Woodstock, GA 30188

CURRENT DRAWING
DATE: 2/18/20
SCALE: NTS
PROJECT #: 3832
DRAWN BY: LBV
CHECKED BY: WAJ

ORIGINAL DRAWING
NO. DATE PROJECT #
0 1/7/16 3832

REFER TO COVER SHEET FOR A COMPLETE LIST OF REVISIONS

SHEET

D1m

*BRICK TIES SPACED @ 16" O.C. HORIZ. & 24" O.C. VERT. AND 3/16" Ø WEEP HOLES @ 33" O.C.

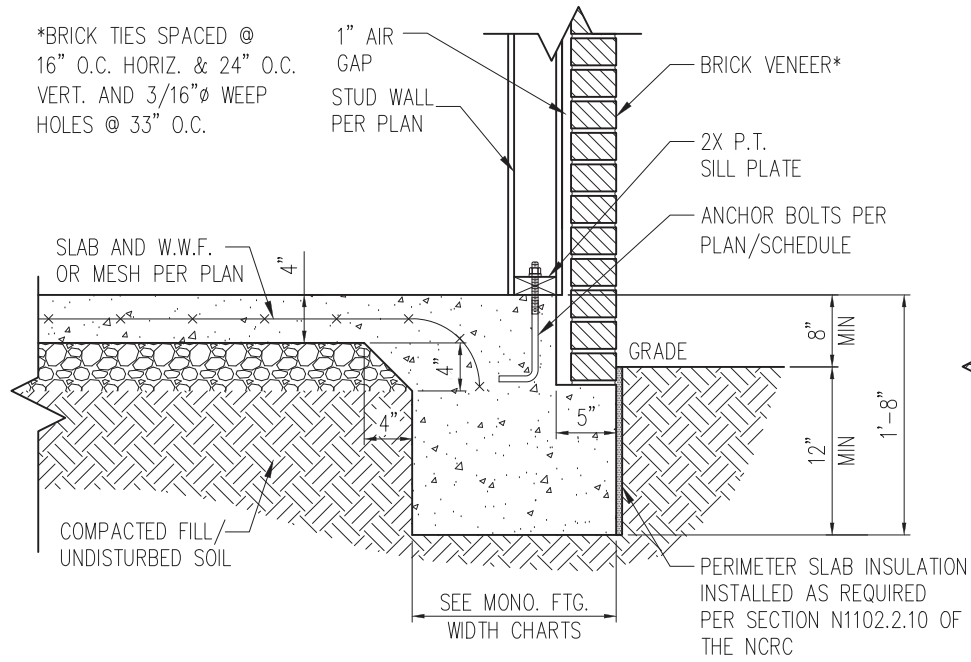

STANDARD - BRICK

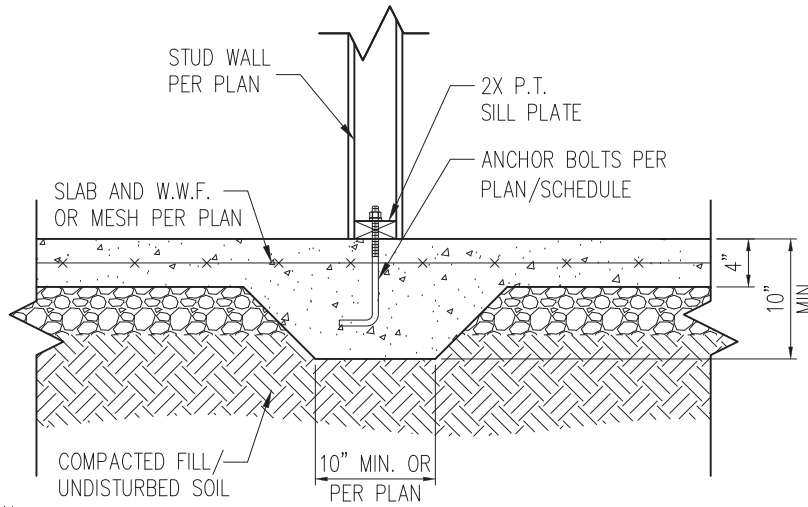

3 TYP. THICKENED SLAB DETAIL
D2m 3/4" = 1'-0"

*BRICK TIES SPACED @ 16" O.C. HORIZ. & 24" O.C. VERT. AND 3/16" Ø WEEP HOLES @ 33" O.C.

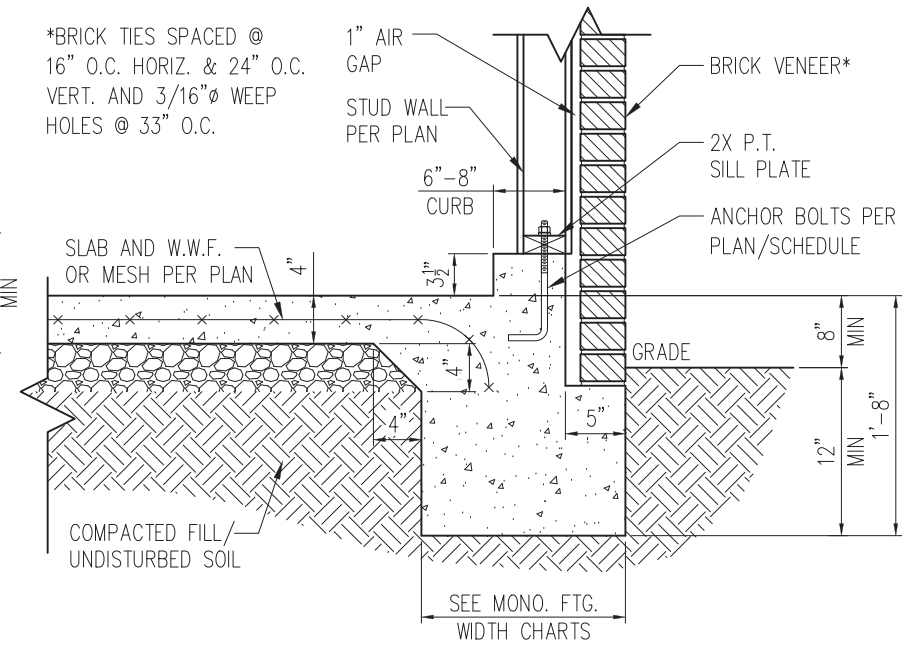

STANDARD - BRICK

5 TYP. GARAGE CURB DETAIL W/ BRICK VENEER
D2m 3/4" = 1'-0"

1 TYP. SLAB DETAIL W/ BRICK VENEER
D2m 3/4" = 1'-0"

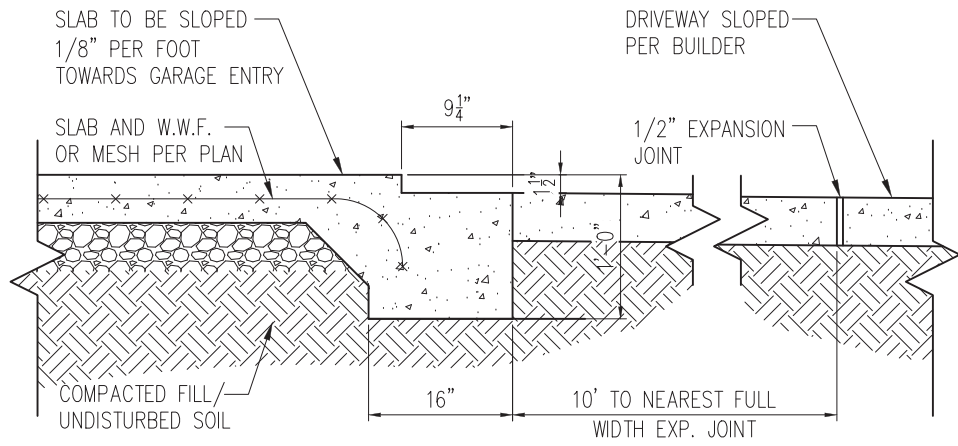

2 SLAB AT GARAGE DOOR
D2m 3/4" = 1'-0"

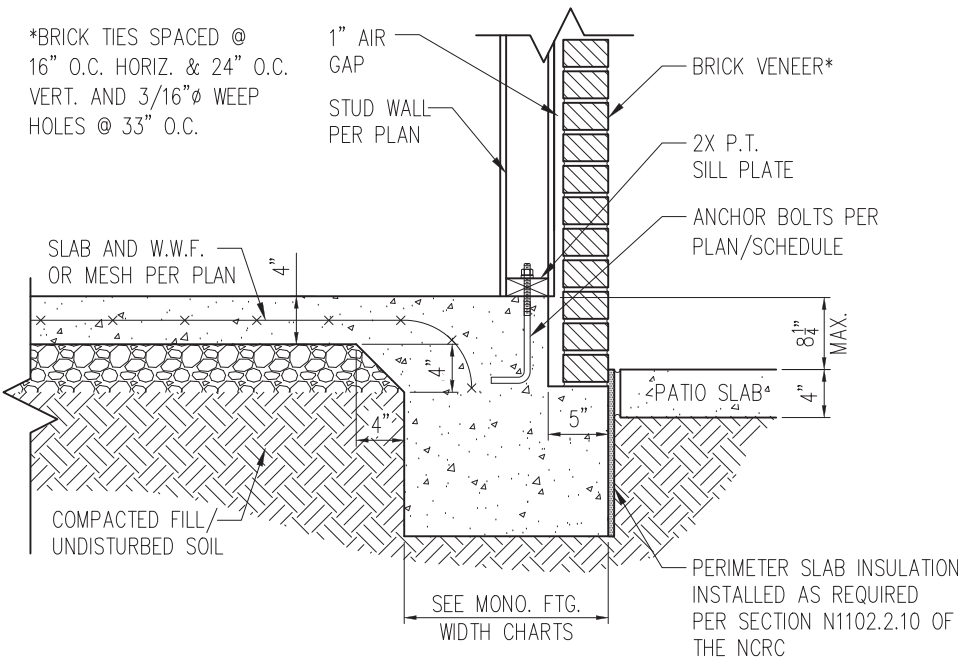

STANDARD - BRICK

4 PATIO SLAB DETAIL W/ BRICK VENEER
D2m 3/4" = 1'-0"

NOTES:

1. REFER TO GENERAL NOTES & SPECIFICATIONS ON SHEET CS2 FOR ADDITIONAL INFORMATION.
2. PROVIDE 6 MIL VAPOR BARRIER UNDER ALL SLABS-ON-GRADE.
3. SEE ARCH. DWGS. FOR ALL TOP OF THE SLAB ELEVATIONS, SLOPES AND DEPRESSIONS.



STRUCTURAL MEMBERS ONLY

SUMMIT
ENGINEERING LABORATORY TESTING
3070 HAMMOND BUSINESS PLACE,
SUITE 171, RALEIGH, NC 27603
OFFICE: 919.380.9991
FAX: 919.380.9993
WWW.SUMMIT-COMPANIES.COM

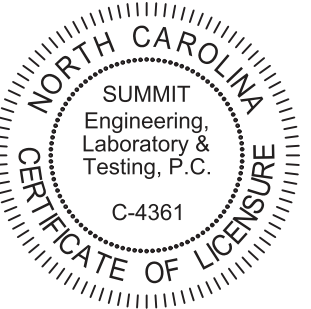

PROJECT
Standard Details
Monolithic Slab Details
CLIENT
Smith Douglas Homes
110 Village Trail, Suite 215
Woodstock, GA 30188

CURRENT DRAWING
DATE: 2/18/20
SCALE: NTS
PROJECT #: 3832
DRAWN BY: LBV
CHECKED BY: WAJ

ORIGINAL DRAWING
NO. DATE PROJECT #
0 1/7/16 3832

REFER TO COVER SHEET FOR A COMPLETE LIST OF REVISIONS

SHEET
D2m

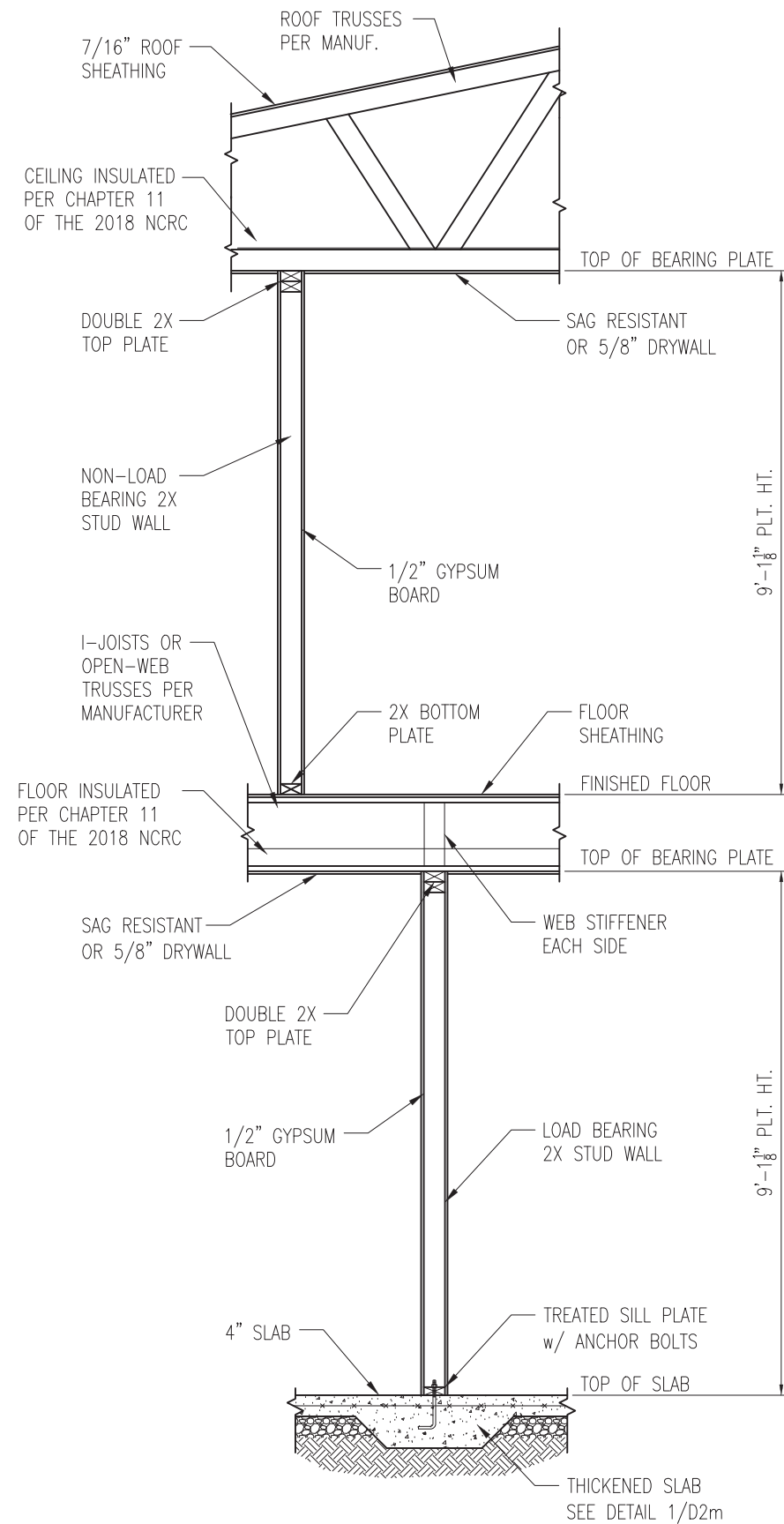

1 TYP. INTERIOR LOAD BEARING WALL SECTION
 D3m 3/4" = 1'-0"

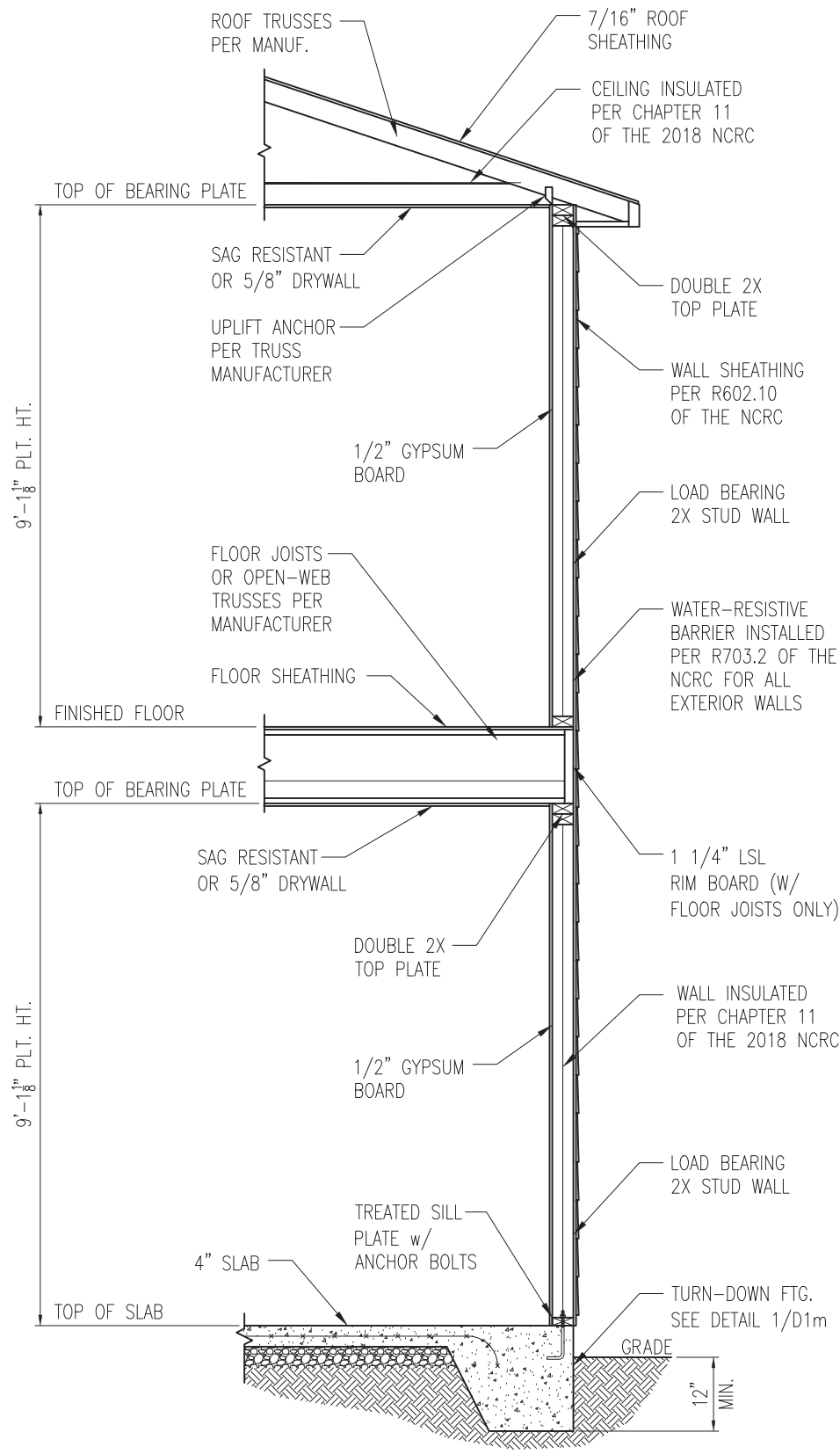

2 TYP. EXTERIOR LOAD BEARING WALL SECTION
 D3m 3/4" = 1'-0"
 -SIMILAR w/ BRICK AND STONE
 -BRICK TIES SPACED @ 16" O.C. HORIZ. & 24" O.C. VERT.
 -MIN. 3/16" Ø WEEP HOLES @ 33" O.C.

- NOTES:
1. REFER TO GENERAL NOTES & SPECIFICATIONS ON SHEET CS2 FOR ADDITIONAL INFORMATION.
 2. PROVIDE 6 MIL VAPOR BARRIER UNDER ALL SLABS-ON-GRADE.
 3. SEE ARCH. DWGS. FOR ALL TOP OF THE SLAB ELEVATIONS, SLOPES AND DEPRESSIONS.



STRUCTURAL MEMBERS ONLY

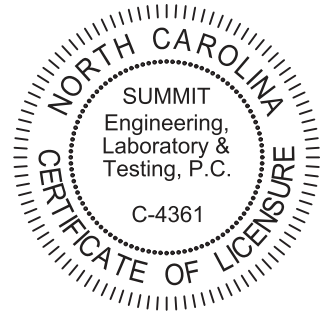

PROJECT
Standard Details
Monolithic Slab Details
 CLIENT
Smith Douglas Homes
 110 Village Trail, Suite 215
 Woodstock, GA 30188

CURRENT DRAWING
 DATE: 2/18/20
 SCALE: NTS
 PROJECT #: 3832
 DRAWN BY: LBV
 CHECKED BY: WAJ

ORIGINAL DRAWING
 NO. DATE PROJECT #
 0 1/7/16 3832

REFER TO COVER SHEET FOR A COMPLETE LIST OF REVISIONS

SHEET
D3m

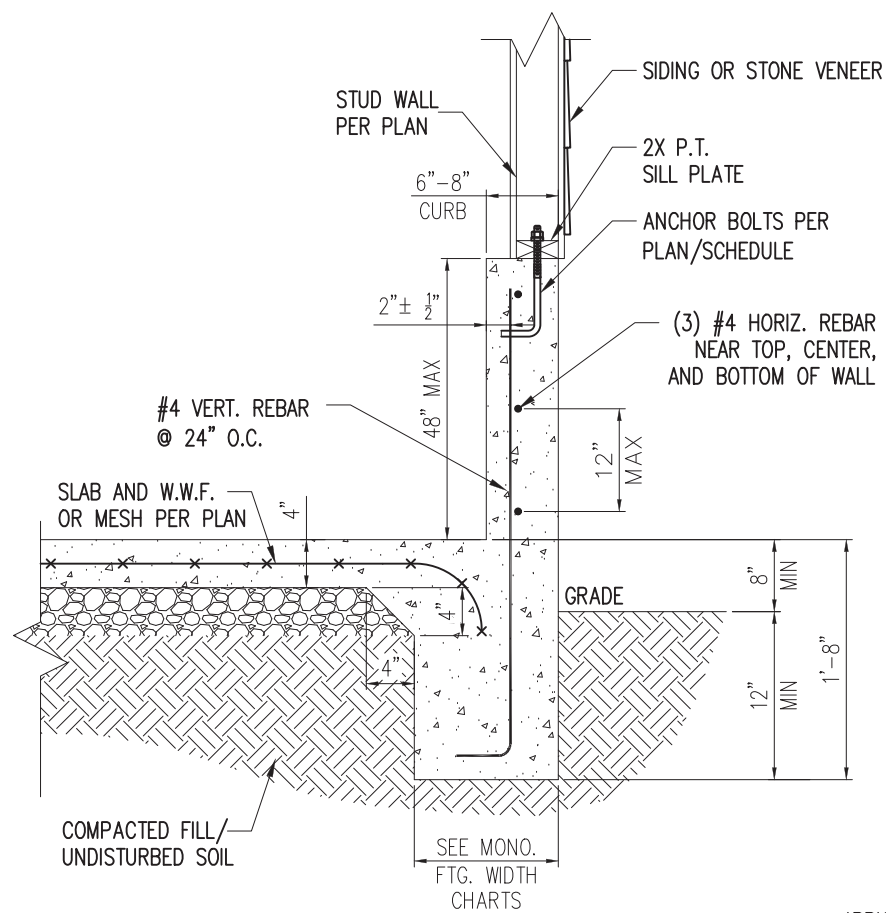

STANDARD - SIDING/STONE

1 EXTENDED GARAGE CURB DETAIL
D4m NTS

*BRICK TIES SPACED @
16" O.C. HORIZ. & 24" O.C.
VERT. AND 3/16" Ø WEEP
HOLES @ 33" O.C.

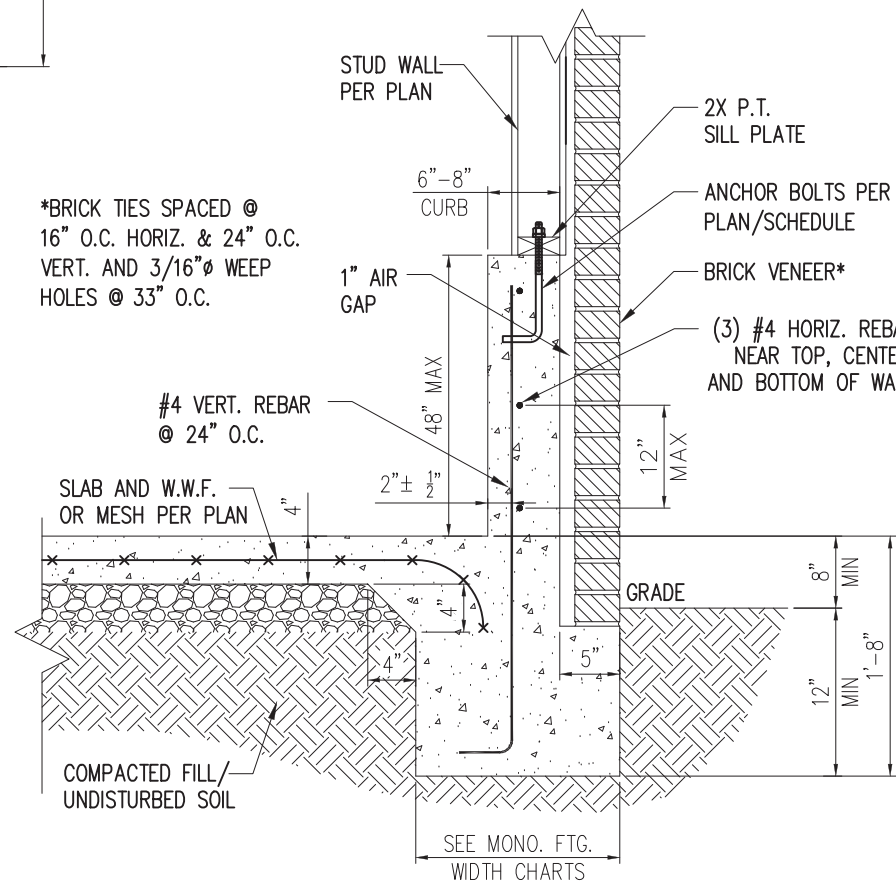

STANDARD - BRICK

3 EXTENDED GARAGE CURB DETAIL
W/ BRICK VENEER
D4m NTS

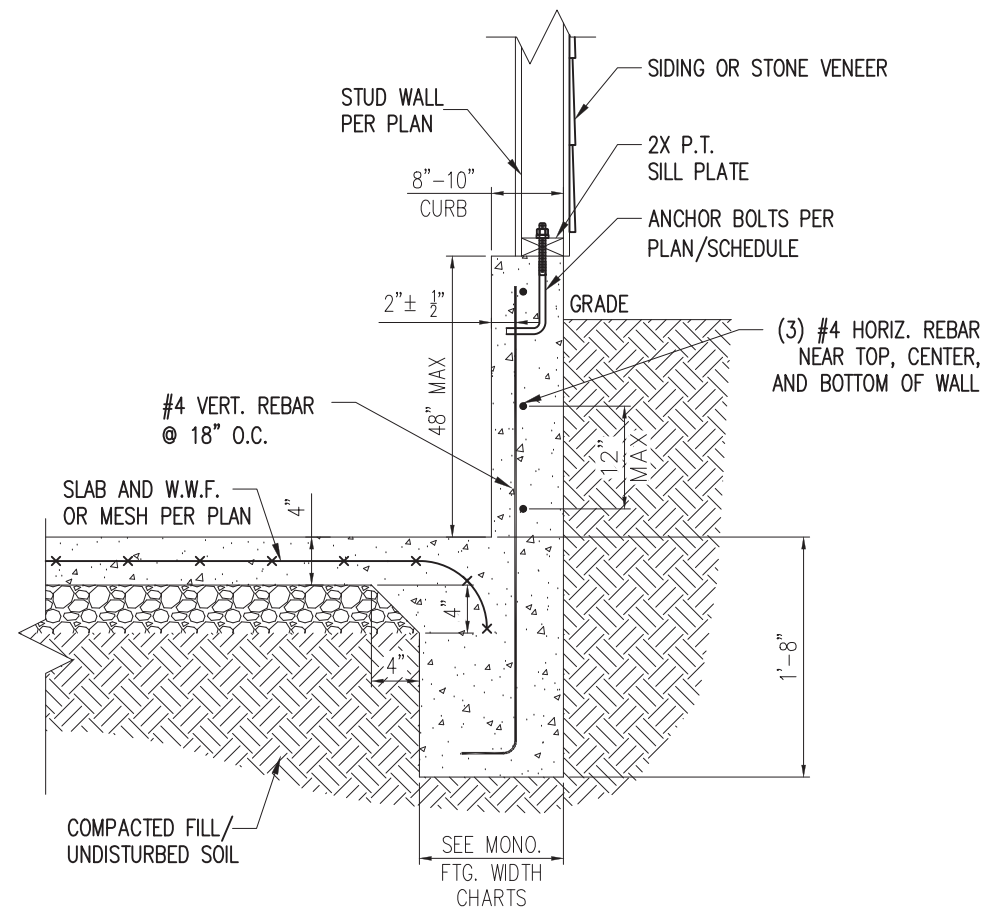

STANDARD - SIDING/STONE

2 EXTENDED GARAGE CURB DETAIL
W/ UNBALANCED FILL
D4m NTS

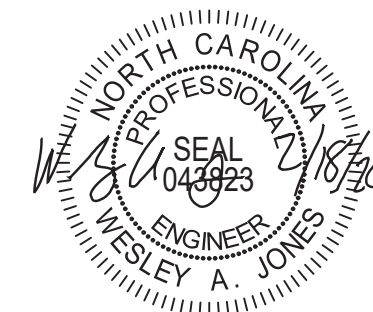

STRUCTURAL MEMBERS ONLY

SUMMIT
ENGINEERING LABORATORY TESTING
3070 HAMMOND BUSINESS PLACE,
SUITE 171, RALEIGH, NC 27603
OFFICE: 919.380.9991
FAX: 919.380.9993
WWW.SUMMIT-COMPANIES.COM

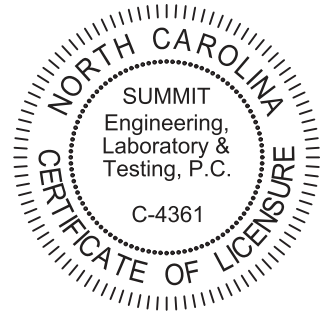

PROJECT
Standard Details
Monolithic Slab Details
CLIENT
Smith Douglas Homes
110 Village Trail, Suite 215
Woodstock, GA 30188

CURRENT DRAWING
DATE: 2/18/20

SCALE: NTS
PROJECT #: 3832

DRAWN BY: LBV
CHECKED BY: WAJ

ORIGINAL DRAWING
NO. DATE PROJECT #
0 1/7/16 3832

REFER TO COVER SHEET FOR A
COMPLETE LIST OF REVISIONS

SHEET

D4m

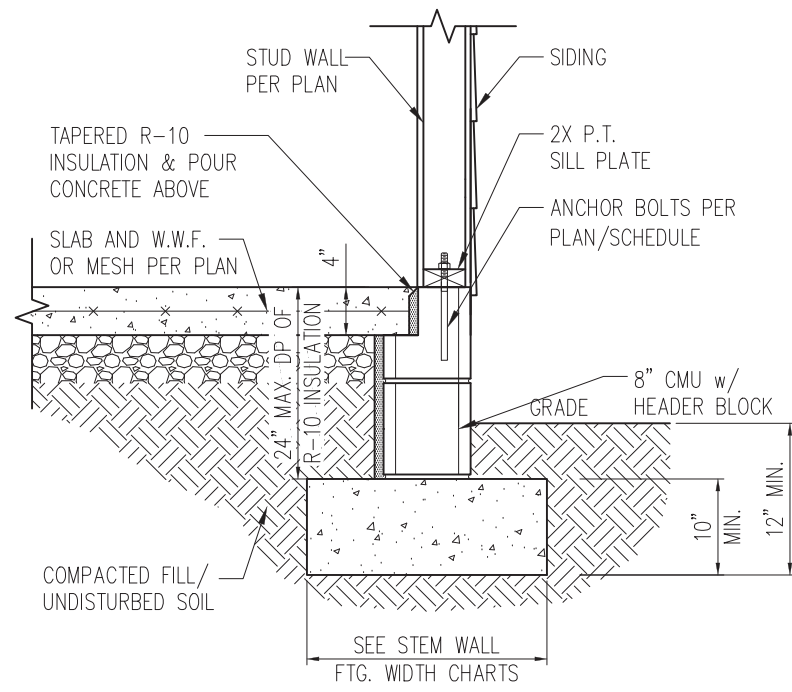

STANDARD - SIDING

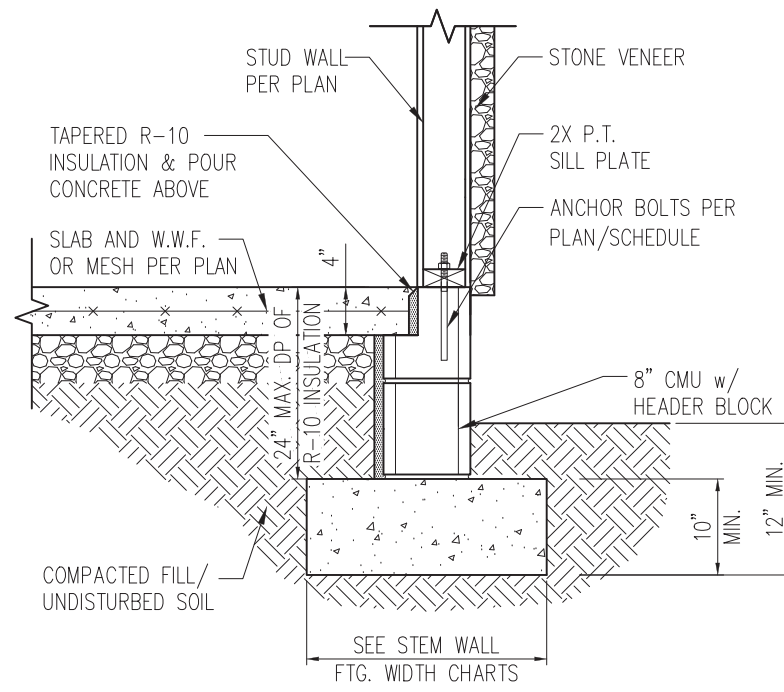

STANDARD - STONE

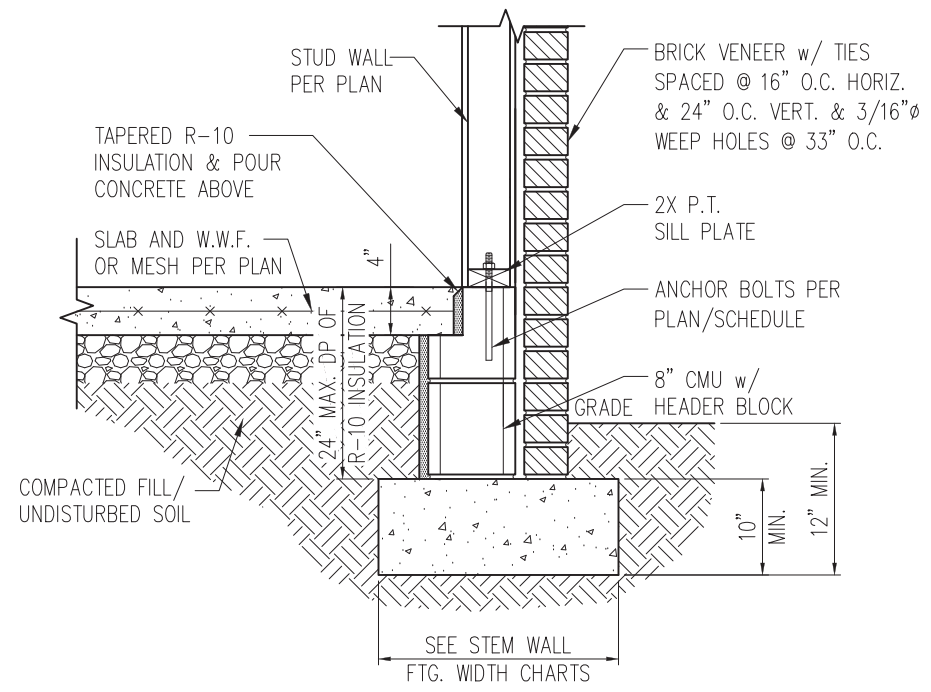

STANDARD - BRICK

1 TYP. STEM WALL DETAIL
D1s 3/4" = 1'-0"

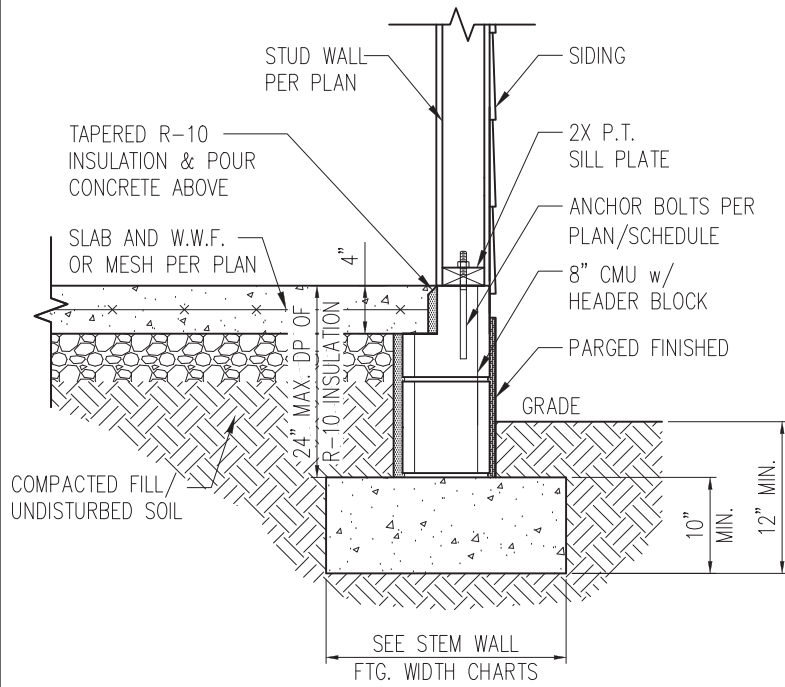

STANDARD - SIDING

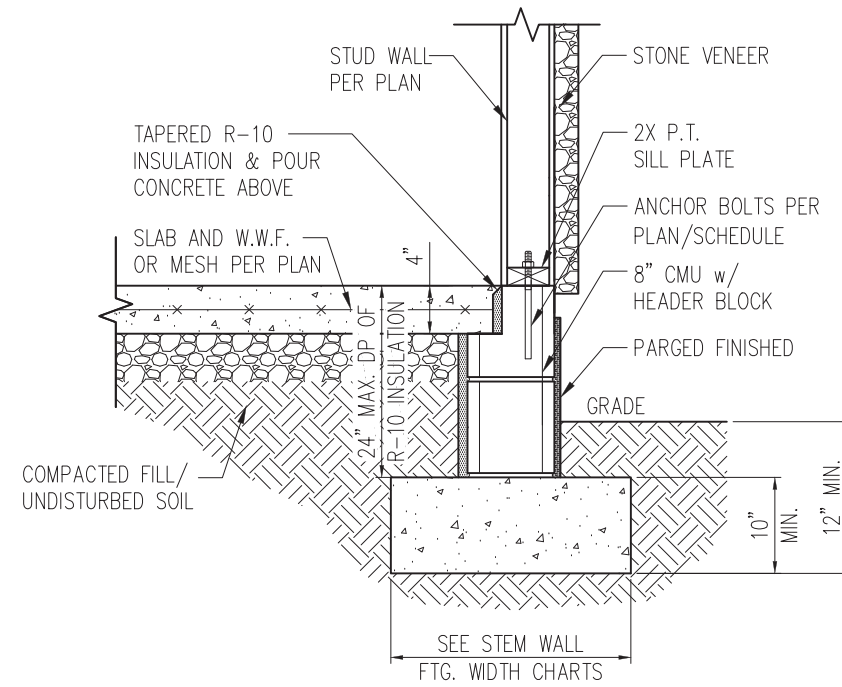

STANDARD - STONE

1a STEM WALL DETAIL w/ PARGED FINISH
D1s 3/4" = 1'-0"

STEM WALL FOOTING WIDTH

# OF STORIES	WIDTH BASED ON SOIL BEARING CAPACITY		
	1500 PSF	2000 PSF	2500 PSF
1 STORY - STD.	16"	16"	16"
1 STORY - BRICK VENEER	21"*	21"*	21"*
2 STORY - STD.	20"	16"	16"
2 STORY - BRICK VENEER	25"*	21"*	21"*

*5" BRICK LEDGE HAS BEEN ADDED TO THE STEM WALL FOOTING WIDTH FOR BRICK SUPPORT

WALL ANCHOR SCHEDULE

TYPE OF ANCHOR	MIN. CONC. EMBEDMENT	SPACING EMBEDMENT	INTERIOR WALL	EXTERIOR WALL
1/2" A307 BOLTS w/ STD. 90° BEND	7"	6'-0"	YES	YES
SST - MAS	4"	5'-0"	NO	YES
HILTI KWIK BOLT KBI 1/2-2-3/4	2-1/4"	6'-0"	YES	NO
1/2" HILTI THREADED ROD w/ HIT HY150 ADHESIVE	7"	6'-0"	YES	YES

NOTE: INSTALL ALL ANCHORS 12" MAX. FROM ALL BOTTOM PLATE ENDS AND JOINTS.

NOTES:

- REFER TO GENERAL NOTES & SPECIFICATIONS ON SHEET CS2 FOR ADDITIONAL INFORMATION.
- PROVIDE 6 MIL VAPOR BARRIER UNDER ALL SLABS-ON-GRADE.
- SEE ARCH. DWGS. FOR ALL TOP OF THE SLAB ELEVATIONS, SLOPS AND DEPRESSIONS.

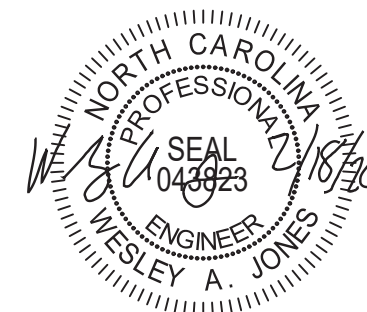

STRUCTURAL MEMBERS ONLY

SUMMIT
ENGINEERING LABORATORY TESTING
3070 HAMMOND BUSINESS PLACE,
SUITE 171, RALEIGH, NC 27603
OFFICE: 919.380.9991
FAX: 919.380.9993
WWW.SUMMIT-COMPANIES.COM

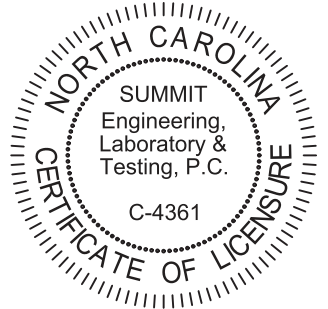

PROJECT
Standard Details
Stemwall Details
CLIENT
Smith Douglas Homes
110 Village Trail, Suite 215
Woodstock, GA 30188

CURRENT DRAWING
DATE: 2/18/20
SCALE: NTS
PROJECT #: 3832
DRAWN BY: LBV
CHECKED BY: WAJ

ORIGINAL DRAWING
NO. DATE PROJECT #
0 1/7/16 3832

REFER TO COVER SHEET FOR A COMPLETE LIST OF REVISIONS

SHEET
D1s

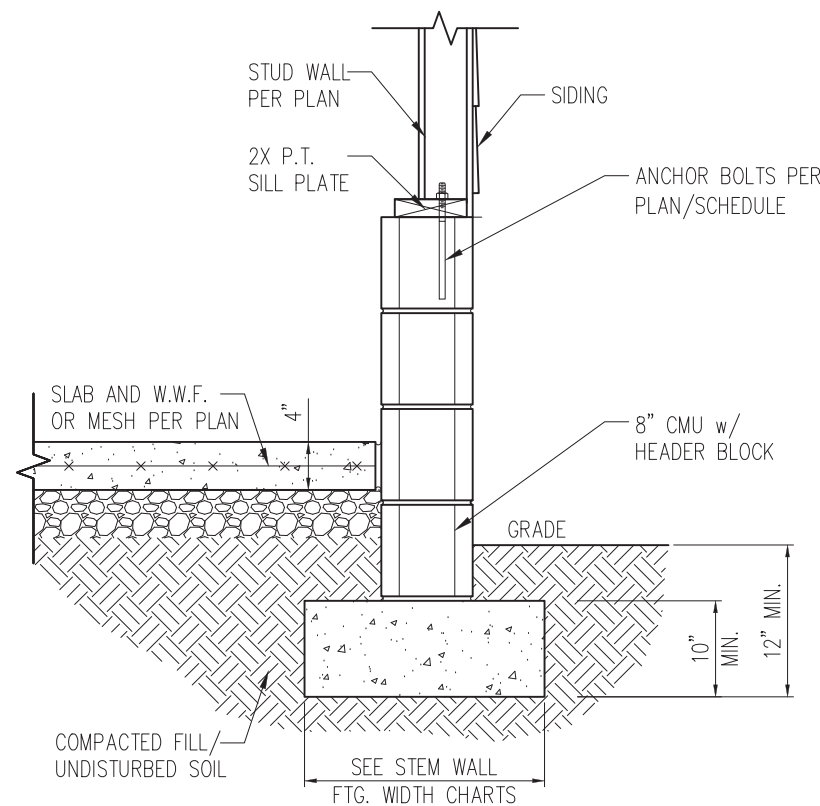

STANDARD - SIDING

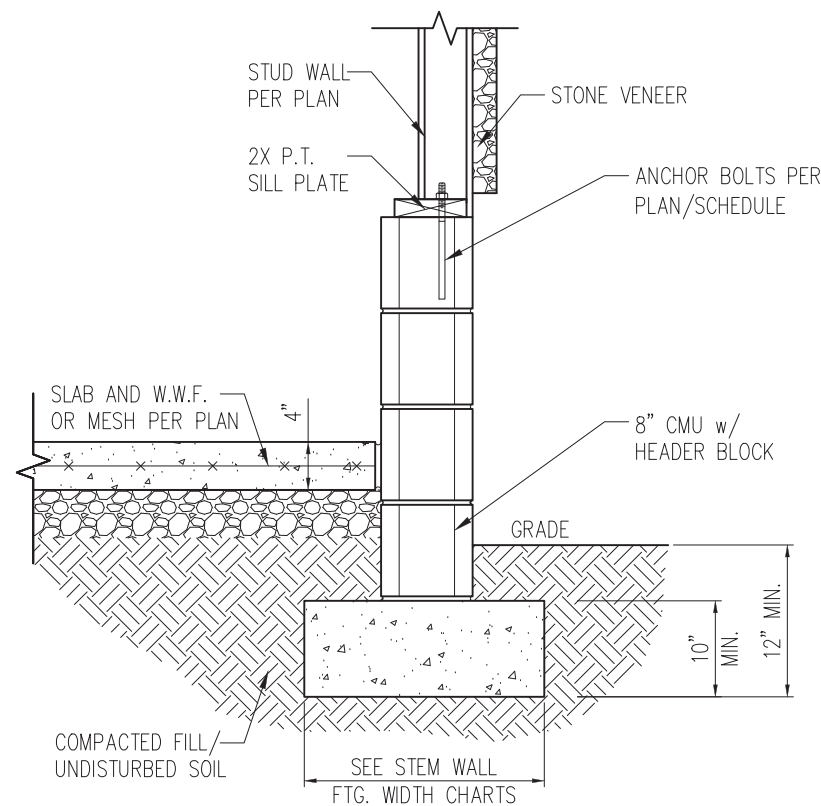

STANDARD - STONE

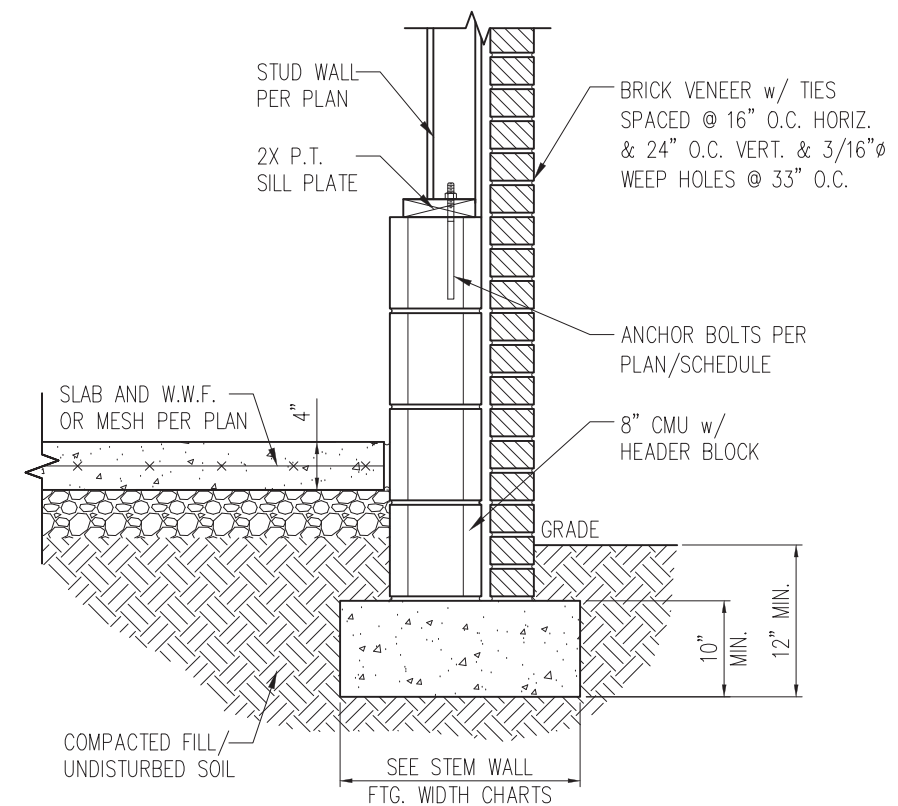

STANDARD - BRICK

1 TYP. GARAGE CURB DETAIL
D2s 3/4" = 1'-0"

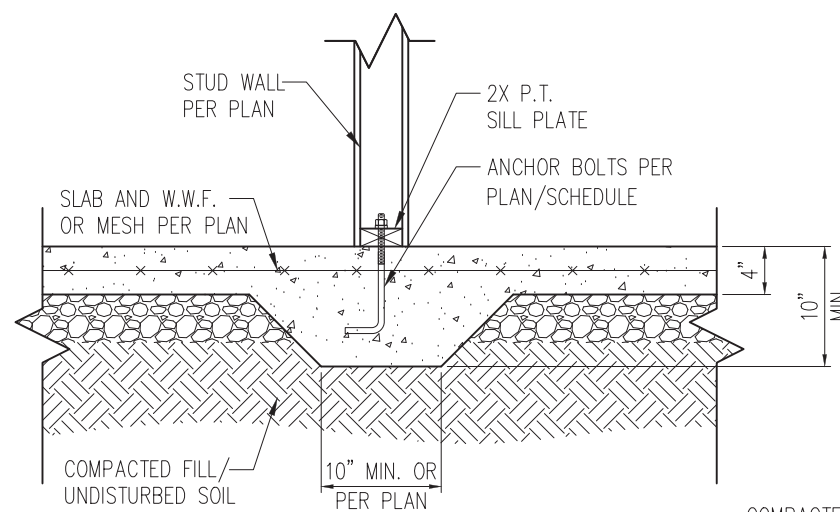

2 TYP. THICKENED SLAB DETAIL
D2s 3/4" = 1'-0"

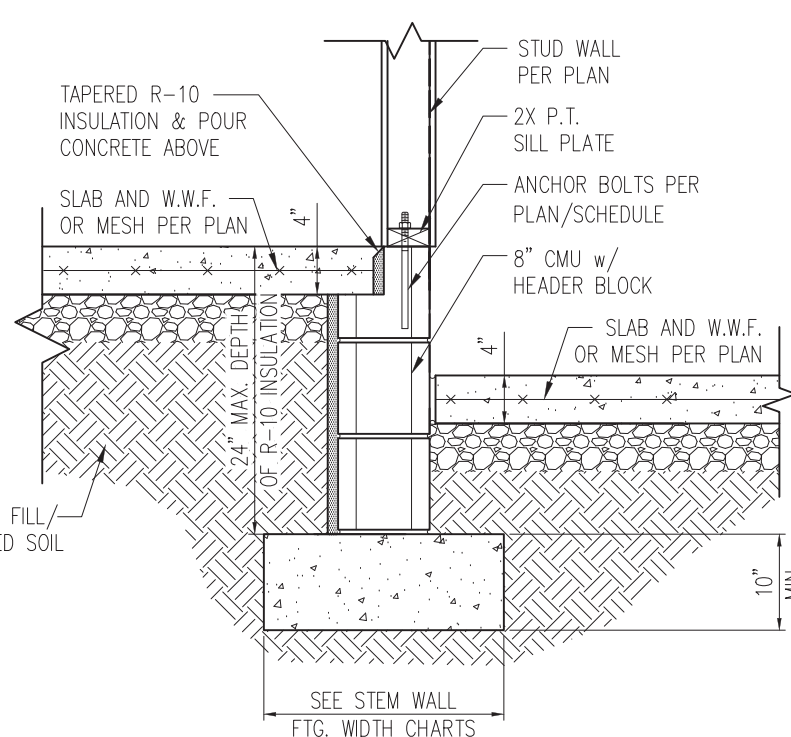

3 HOUSE/GARAGE WALL DETAIL
D2s 3/4" = 1'-0"

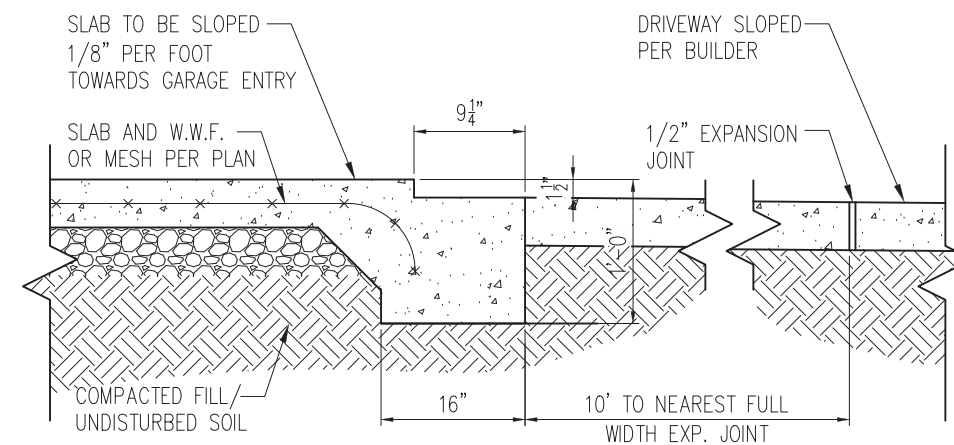

4 SLAB AT GARAGE DOOR
D2s 3/4" = 1'-0"

- NOTES:
- REFER TO GENERAL NOTES & SPECIFICATIONS ON SHEET CS2 FOR ADDITIONAL INFORMATION.
 - PROVIDE 6 MIL VAPOR BARRIER UNDER ALL SLABS-ON-GRADE.
 - SEE ARCH. DWGS. FOR ALL TOP OF THE SLAB ELEVATIONS, SLOPES AND DEPRESSIONS.

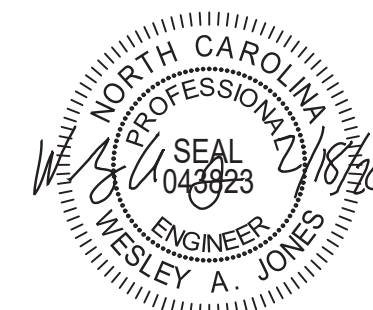

STRUCTURAL MEMBERS ONLY

SUMMIT
ENGINEERING LABORATORY TESTING
3070 HAMMOND BUSINESS PLACE,
SUITE 171, RALEIGH, NC 27603
OFFICE: 919.380.9991
FAX: 919.380.9993
WWW.SUMMIT-COMPANIES.COM

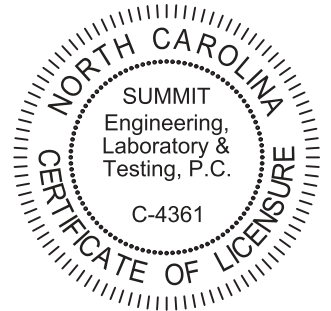

PROJECT
Standard Details
Stemwall Details
CLIENT
Smith Douglas Homes
110 Village Trail, Suite 215
Woodstock, GA 30188

CURRENT DRAWING		
DATE: 2/18/20		
SCALE: NTS		
PROJECT #: 3832		
DRAWN BY: LBV		
CHECKED BY: WAJ		
ORIGINAL DRAWING		
NO.	DATE	PROJECT #
0	1/7/16	3832

REFER TO COVER SHEET FOR A COMPLETE LIST OF REVISIONS

SHEET
D2s

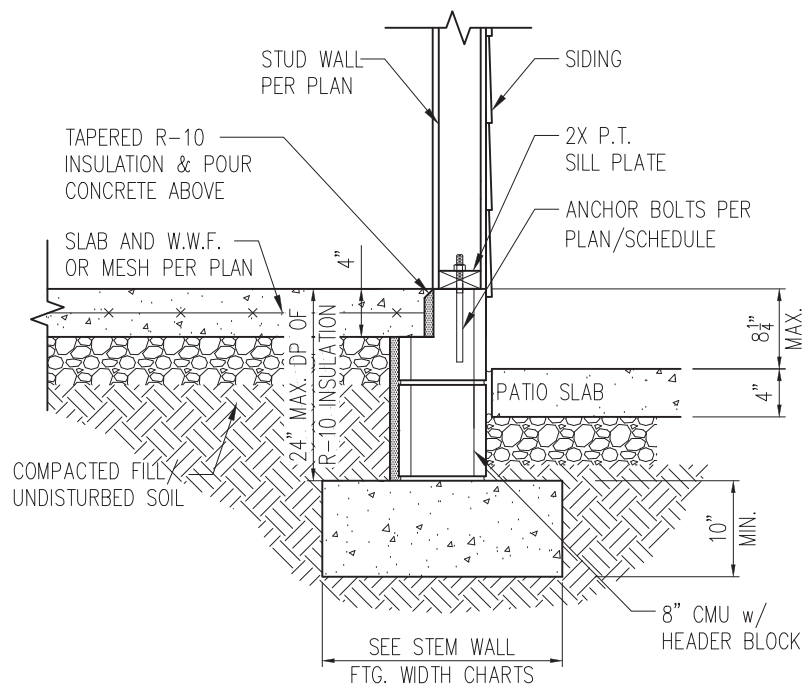

STANDARD - SIDING

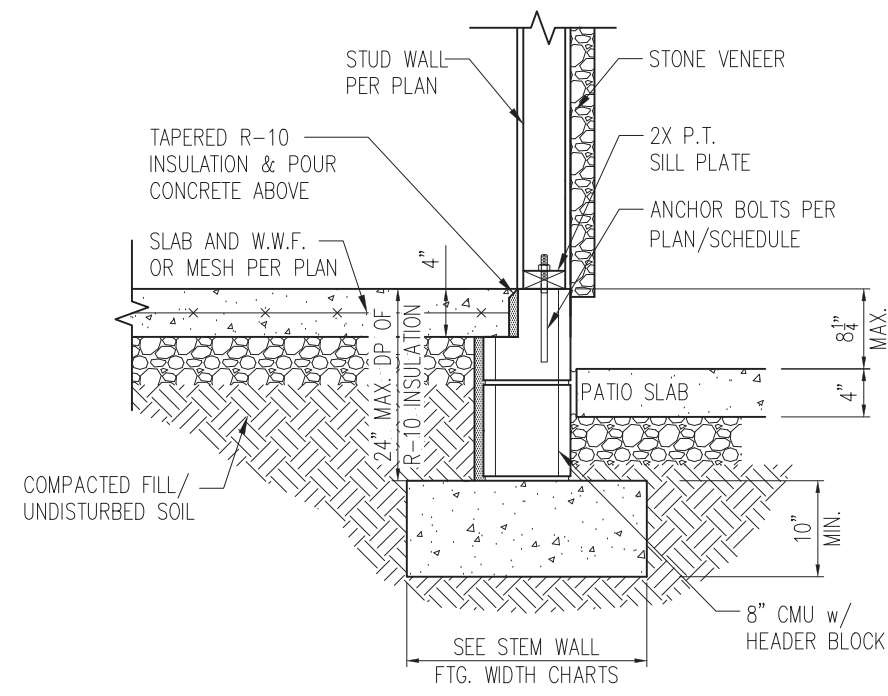

STANDARD - STONE

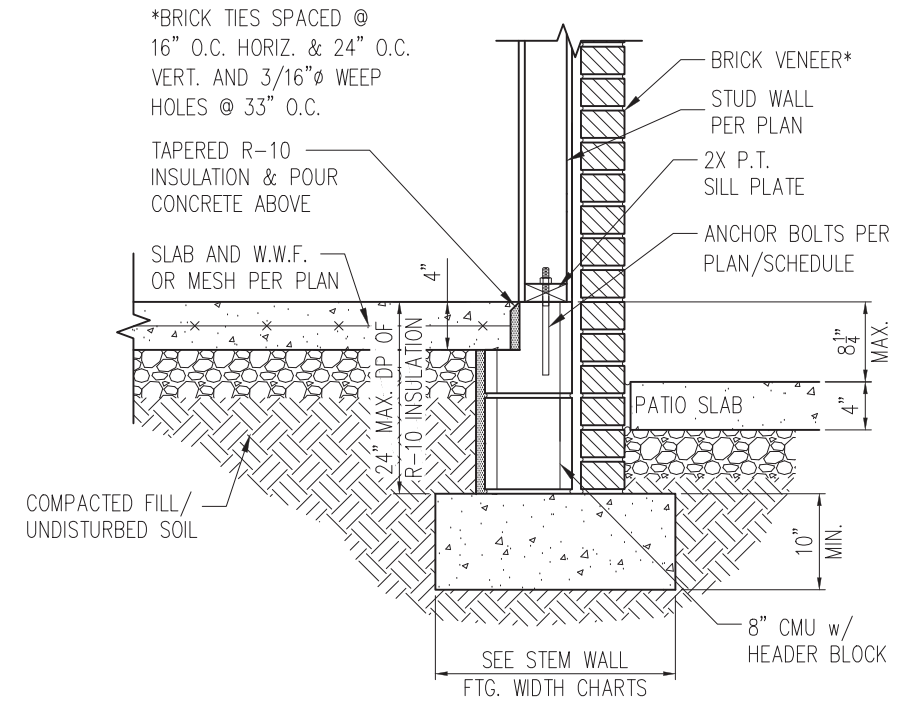

STANDARD - BRICK

1 PORCH SLAB DETAIL
D3s 3/4" = 1'-0"

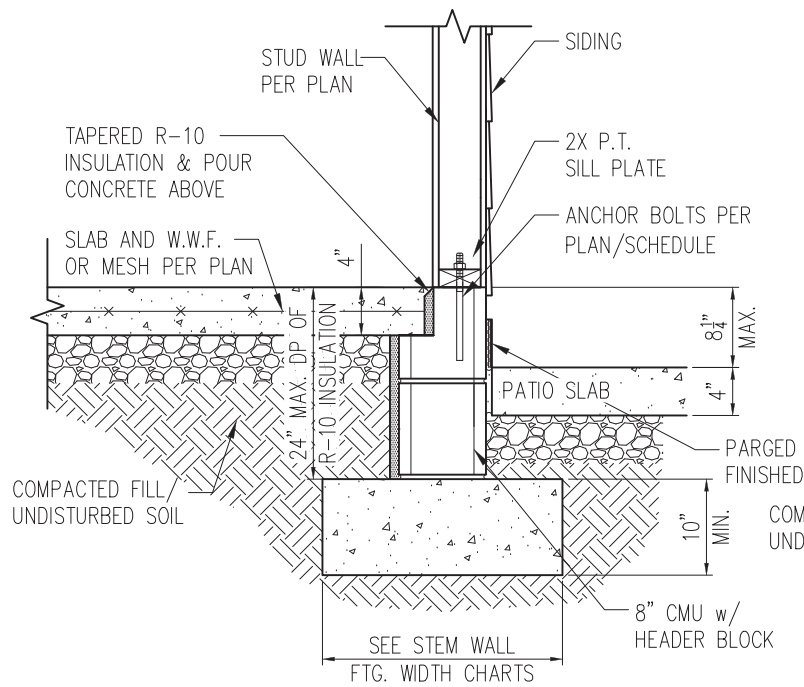

STANDARD - SIDING

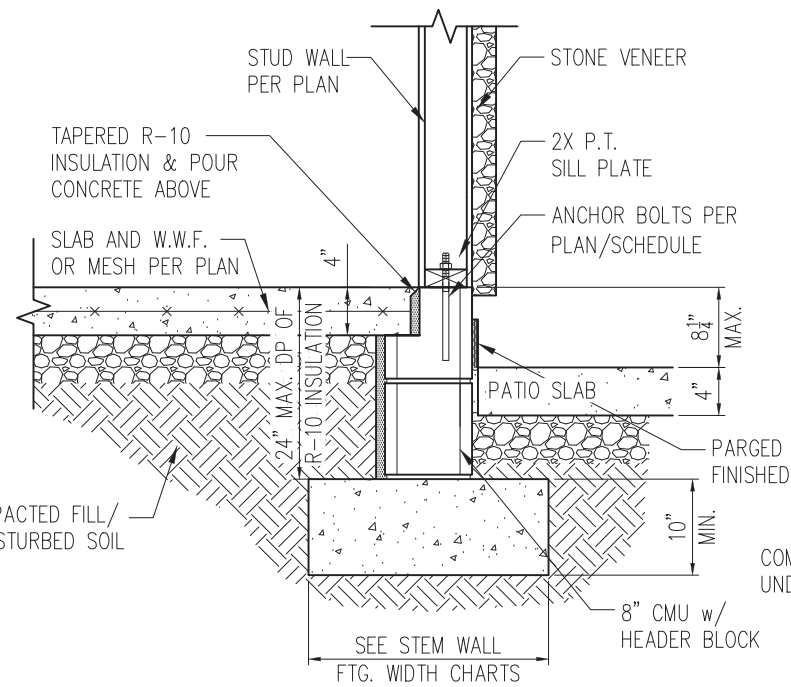

STANDARD - STONE

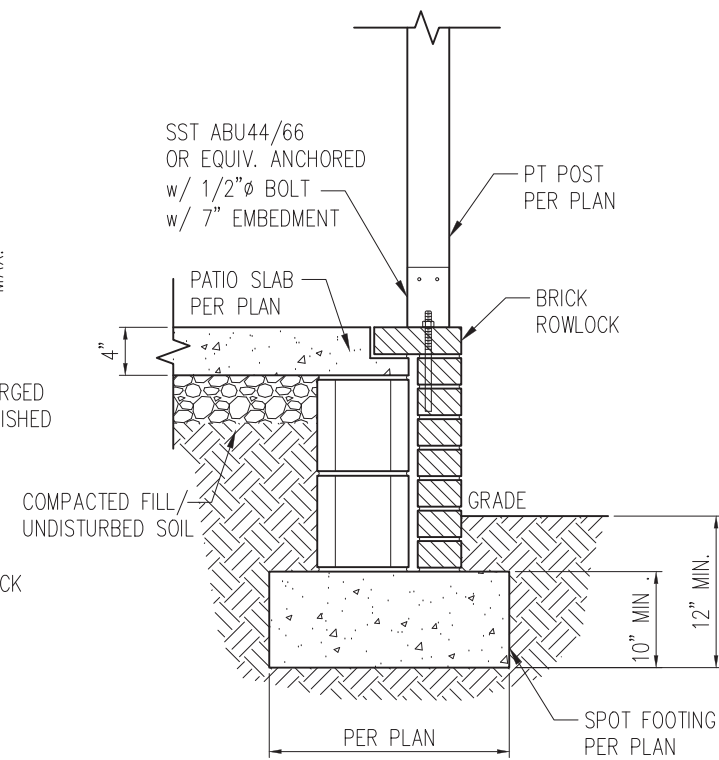

2 COVERED PORCH DETAIL
D3s 3/4" = 1'-0"

- NOTES:
1. REFER TO GENERAL NOTES & SPECIFICATIONS ON SHEET CS2 FOR ADDITIONAL INFORMATION.
 2. PROVIDE 6 MIL VAPOR BARRIER UNDER ALL SLABS-ON-GRADE.
 3. SEE ARCH. DWGS. FOR ALL TOP OF THE SLAB ELEVATIONS, SLOPES AND DEPRESSIONS.

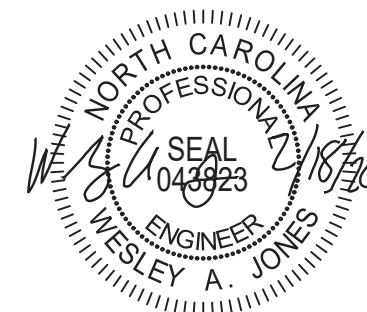

STRUCTURAL MEMBERS ONLY

SUMMIT
ENGINEERING LABORATORY TESTING
3070 HAMMOND BUSINESS PLACE,
SUITE 171, RALEIGH, NC 27603
OFFICE: 919.380.9991
FAX: 919.380.9993
WWW.SUMMIT-COMPANIES.COM

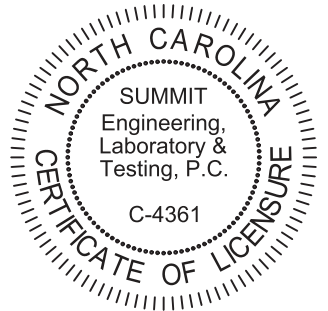

PROJECT
Standard Details
Stemwall Details
CLIENT
Smith Douglas Homes
110 Village Trail, Suite 215
Woodstock, GA 30188

CURRENT DRAWING
DATE: 2/18/20
SCALE: NTS
PROJECT #: 3832
DRAWN BY: LBV
CHECKED BY: WAJ

ORIGINAL DRAWING
NO. DATE PROJECT #
0 1/7/16 3832

REFER TO COVER SHEET FOR A COMPLETE LIST OF REVISIONS

SHEET
D3s

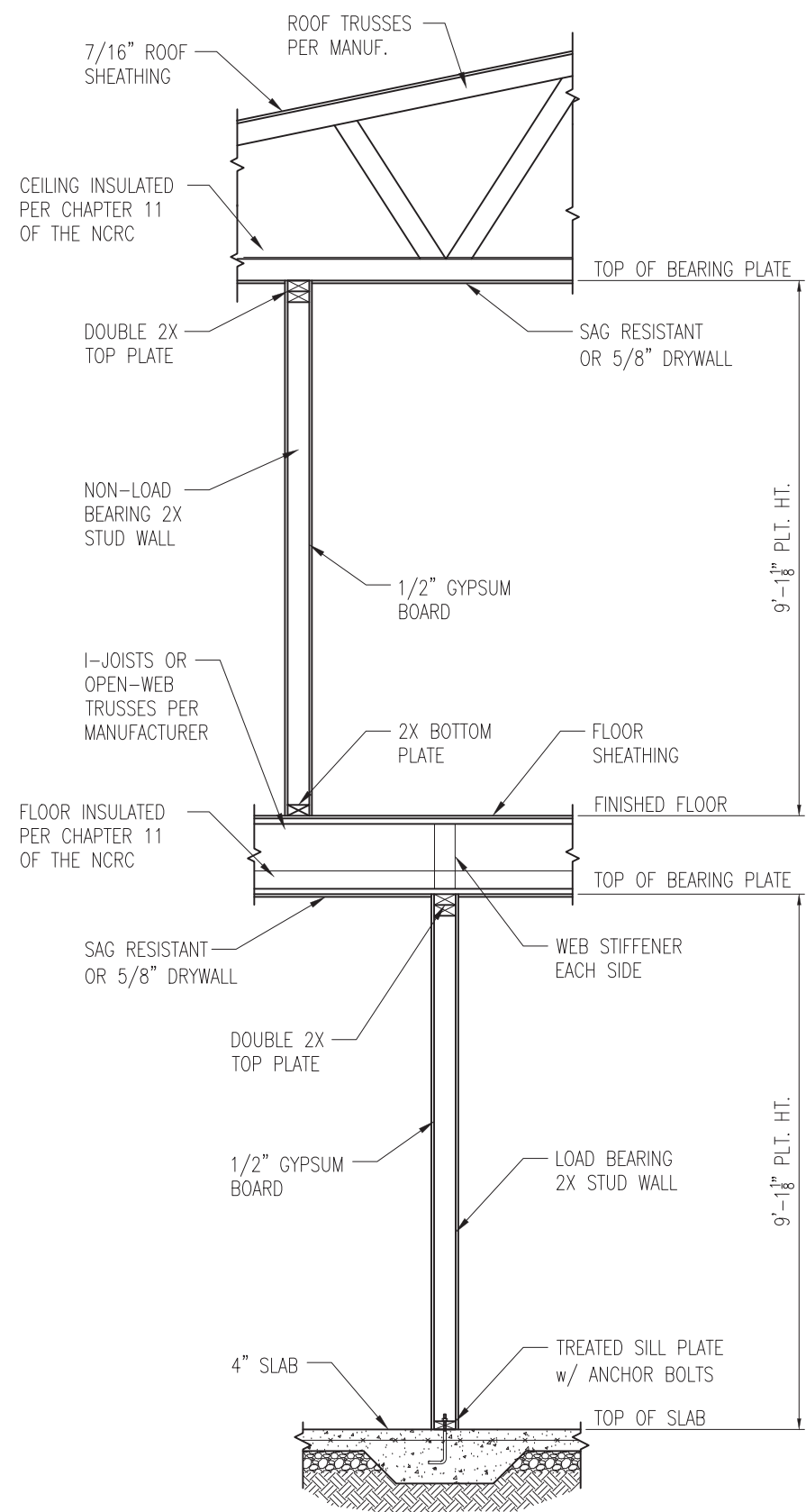

1 TYP. INTERIOR LOAD BEARING WALL SECTION
 D4s 3/4" = 1'-0"

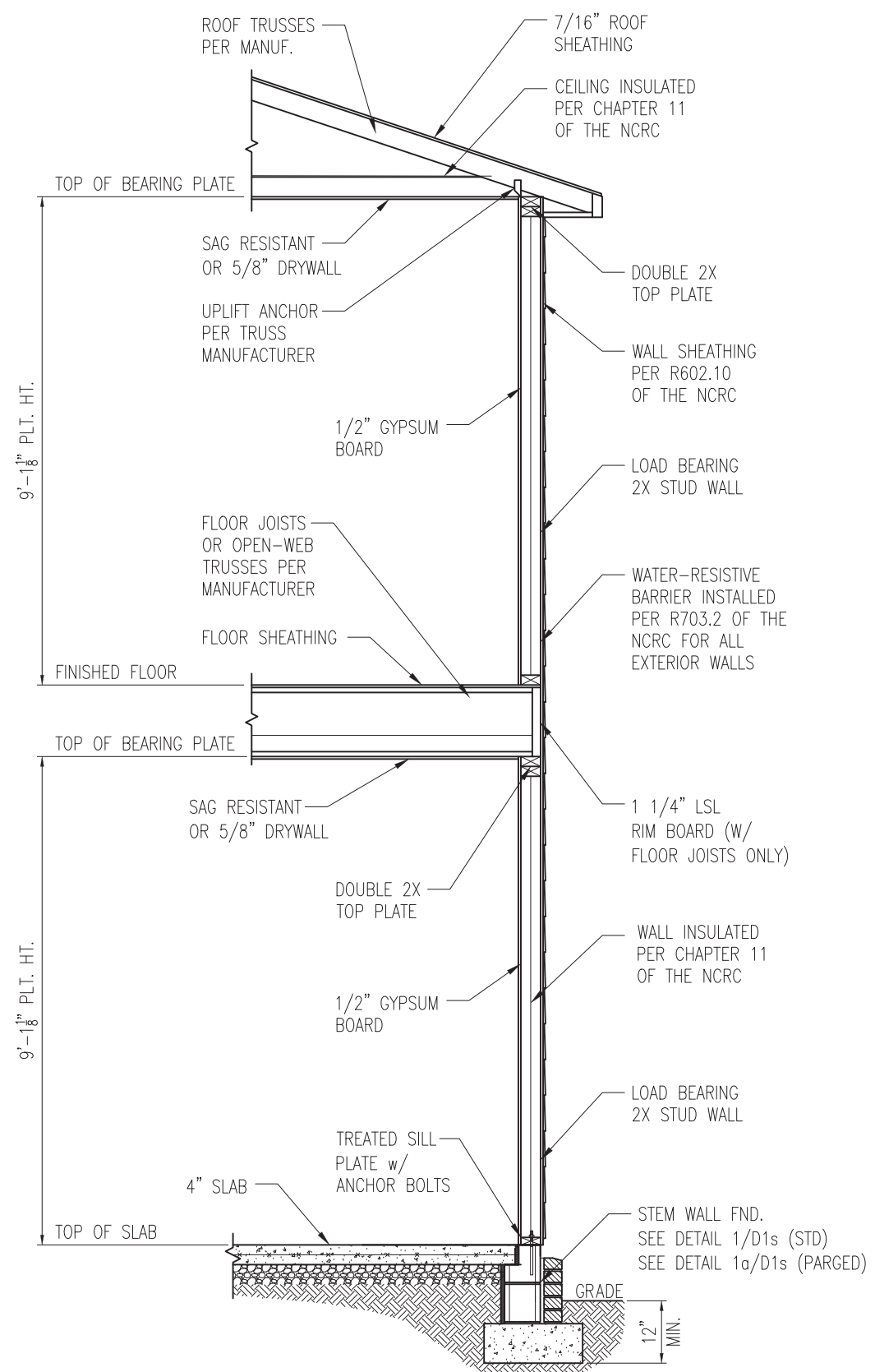

2 TYP. EXTERIOR LOAD BEARING WALL SECTION
 D4s 3/4" = 1'-0"
 -SIMILAR w/ BRICK AND STONE
 -BRICK TIES SPACED @ 16" O.C. HORIZ. & 24" O.C. VERT.
 -MIN. 3/16" WEEP HOLES @ 33" O.C.

- NOTES:
1. REFER TO GENERAL NOTES & SPECIFICATIONS ON SHEET CS2 FOR ADDITIONAL INFORMATION.
 2. PROVIDE 6 MIL VAPOR BARRIER UNDER ALL SLABS-ON-GRADE.
 3. SEE ARCH. DWGS. FOR ALL TOP OF THE SLAB ELEVATIONS, SLOPES AND DEPRESSIONS.



STRUCTURAL MEMBERS ONLY

SUMMIT
 ENGINEERING LABORATORY TESTING
 3070 HAMMOND BUSINESS PLACE,
 SUITE 171, RALEIGH, NC 27603
 OFFICE: 919.380.9991
 FAX: 919.380.9993
 WWW.SUMMIT-COMPANIES.COM

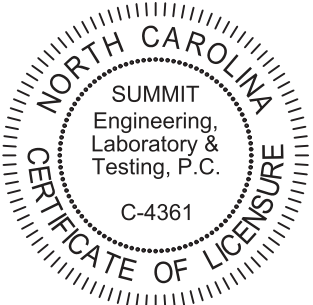

PROJECT
Standard Details
Stemwall Details
 CLIENT
Smith Douglas Homes
 110 Village Trail, Suite 215
 Woodstock, GA 30188

CURRENT DRAWING
 DATE: 2/18/20
 SCALE: NTS
 PROJECT #: 3832
 DRAWN BY: LBV
 CHECKED BY: WAJ

ORIGINAL DRAWING
 NO. DATE PROJECT #
 0 1/7/16 3832

REFER TO COVER SHEET FOR A COMPLETE LIST OF REVISIONS

SHEET
D4s

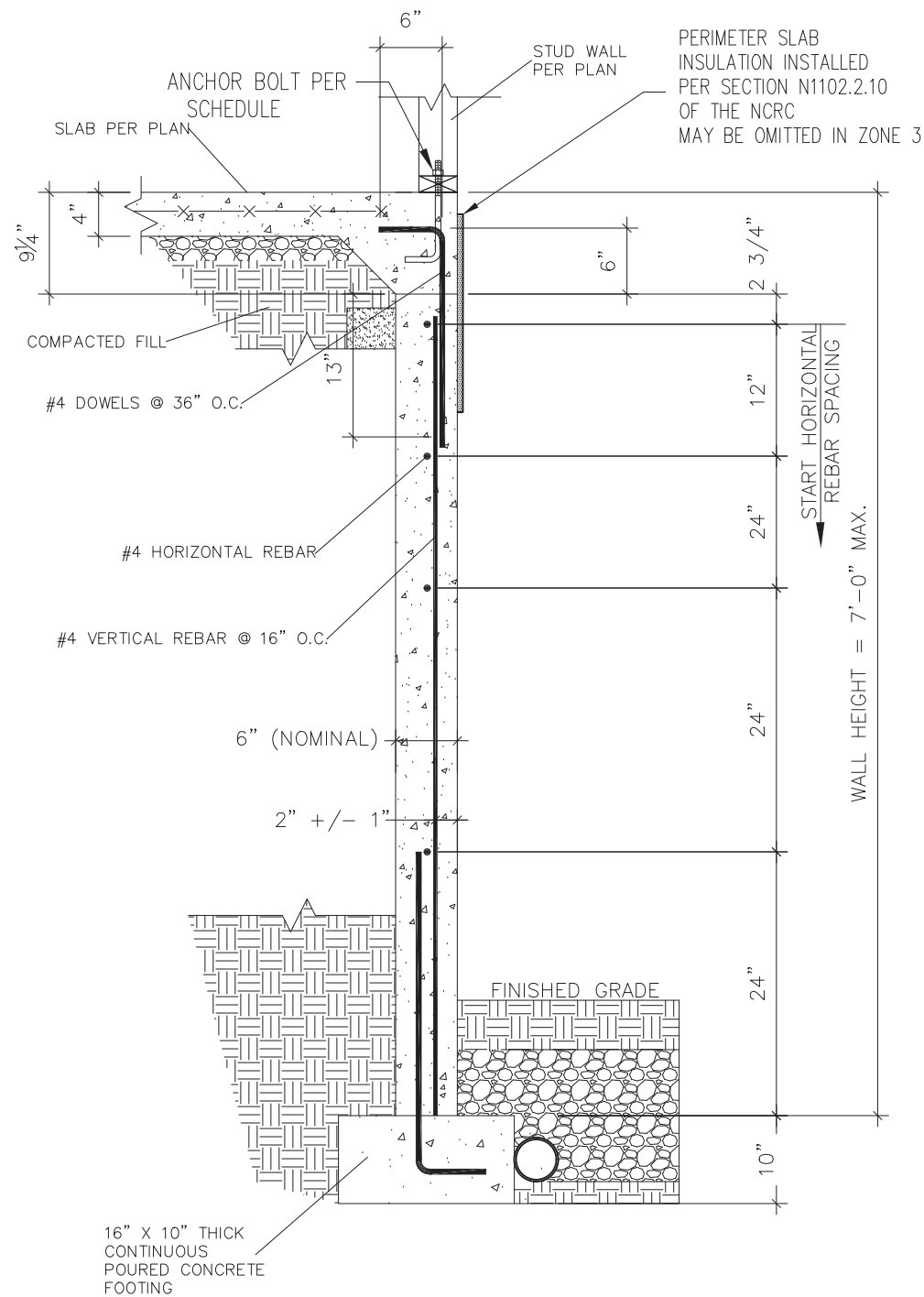

1 SUBWALL FOUNDATION
 D5s 3/4" = 1'-0"

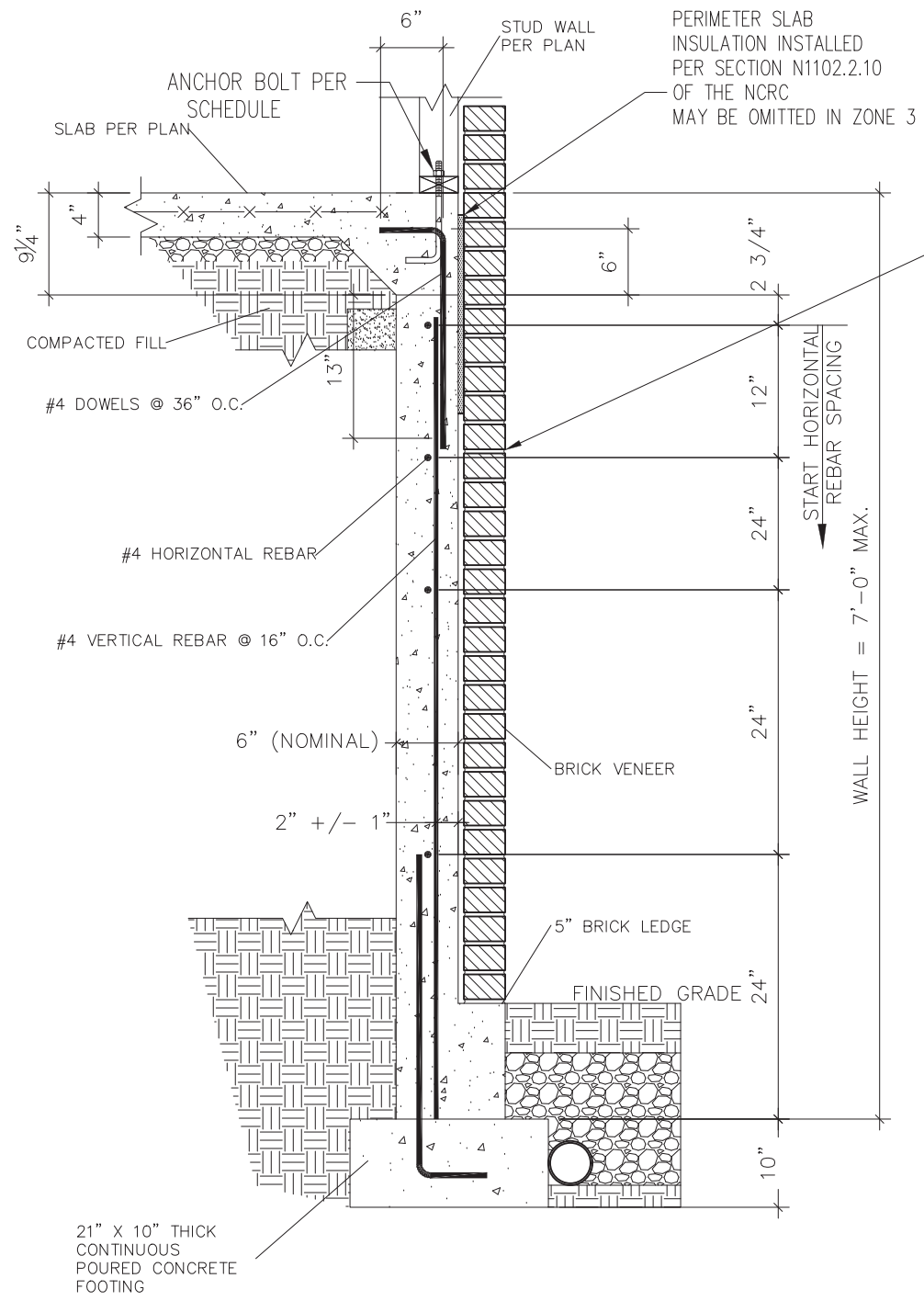

2 SUBWALL FOUNDATION W/ BRICK VENEER
 D5s 3/4" = 1'-0"

PROVIDE LADDER WIRE OR METAL TIES, INSTALLED PER R608.1.2 OF THE 2012 NCRC, AND FULLY GROUT BETWEEN BRICK AND CONCRETE.



STRUCTURAL MEMBERS ONLY

SUMMIT
 ENGINEERING LABORATORY TESTING
 3070 HAMMOND BUSINESS PLACE,
 SUITE 171, RALEIGH, NC 27603
 OFFICE: 919.380.9991
 FAX: 919.380.9993
 WWW.SUMMIT-COMPANIES.COM

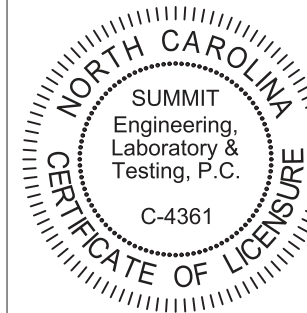

PROJECT
Standard Details
Stemwall Details
 CLIENT
 Smith Douglas Homes
 110 Village Trail, Suite 215
 Woodstock, GA 30188

CURRENT DRAWING
 DATE: 2/18/20
 SCALE: NTS
 PROJECT #: 3832
 DRAWN BY: LBV
 CHECKED BY: WAJ

ORIGINAL DRAWING
 NO. DATE PROJECT #
 0 1/7/16 3832

REFER TO COVER SHEET FOR A COMPLETE LIST OF REVISIONS

SHEET

D5s

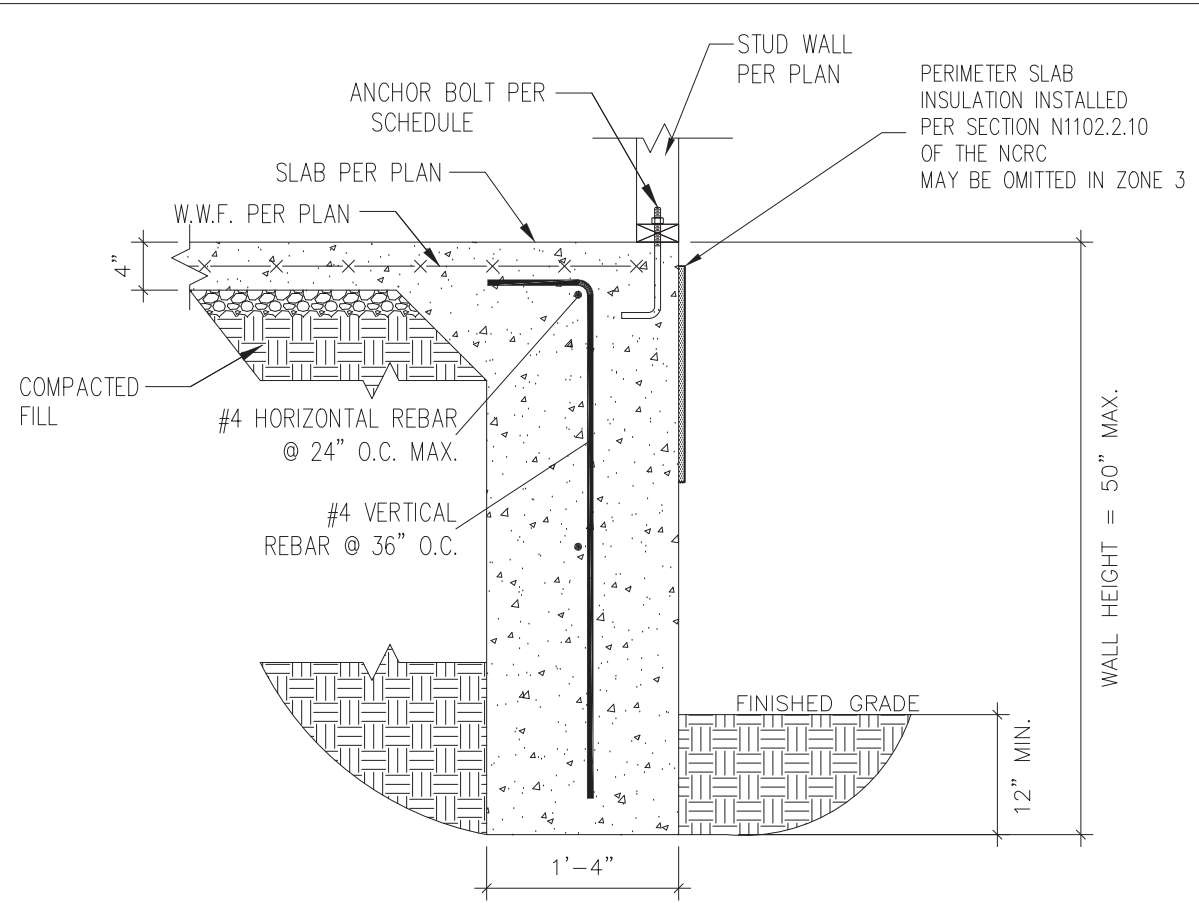

1 TURNDOWN FOUNDATION
 D6s 3/4" = 1'-0"

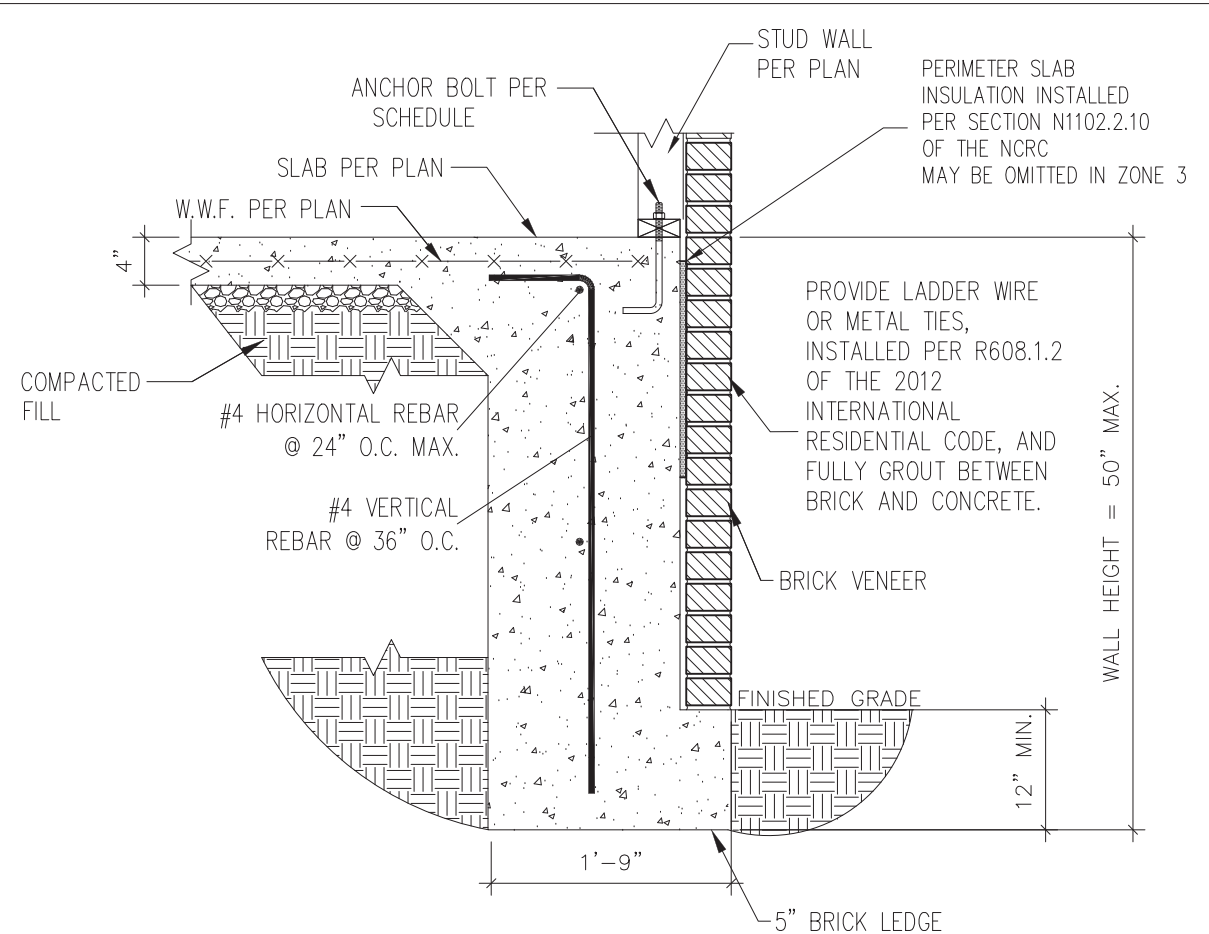

2 TURNDOWN FOUNDATION W/ BRICK VENEER
 D6s 3/4" = 1'-0"

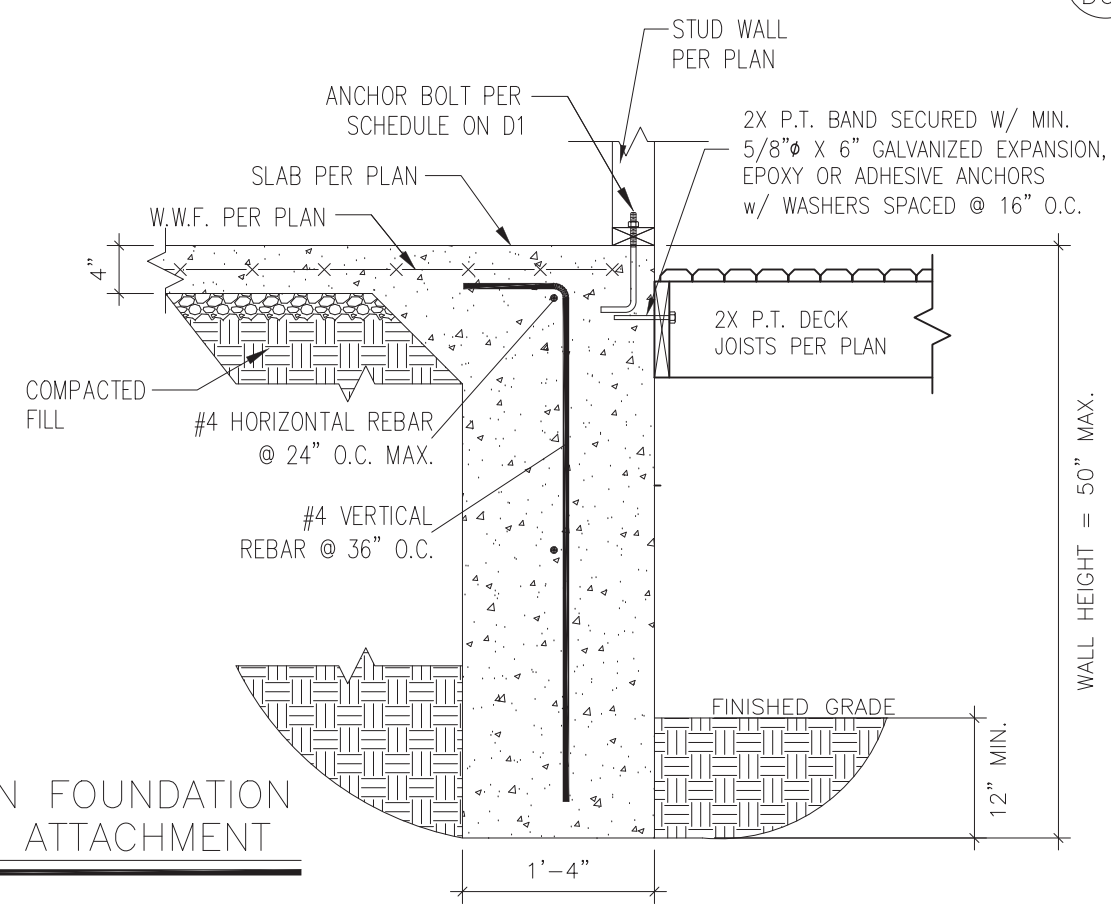

3 TURNDOWN FOUNDATION W/ DECK ATTACHMENT
 D6s 3/4" = 1'-0"



STRUCTURAL MEMBERS ONLY

SUMMIT
 ENGINEERING LABORATORY TESTING
 3070 HAMMOND BUSINESS PLACE,
 SUITE 171, RALEIGH, NC 27603
 OFFICE: 919.380.9991
 FAX: 919.380.9993
 WWW.SUMMIT-COMPANIES.COM

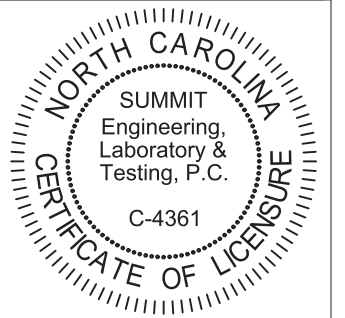

PROJECT
Standard Details
Stemwall Details
 CLIENT
Smith Douglas Homes
 110 Village Trail, Suite 215
 Woodstock, GA 30188

CURRENT DRAWING
 DATE: 2/18/20
 SCALE: NTS
 PROJECT #: 3832
 DRAWN BY: LBV
 CHECKED BY: WAJ

NO.	DATE	PROJECT #
0	1/7/16	3832

REFER TO COVER SHEET FOR A COMPLETE LIST OF REVISIONS

SHEET
D6s

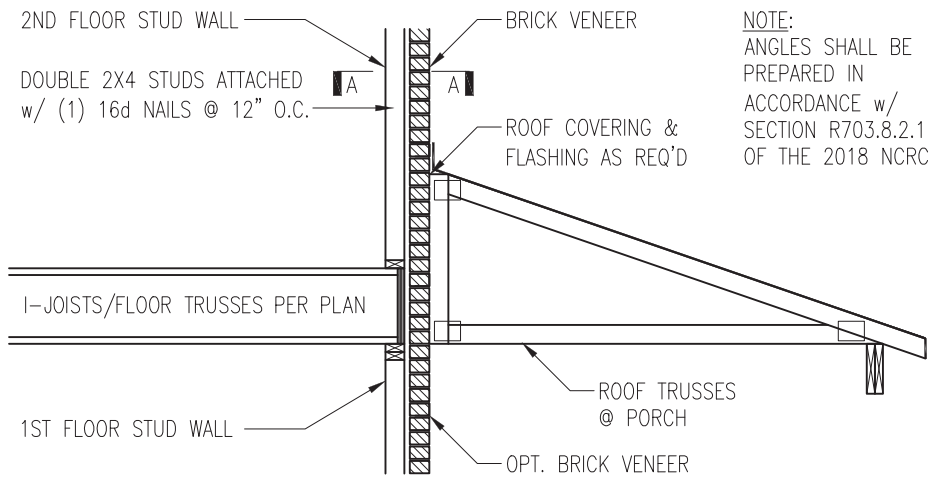

NOTE:
ANGLES SHALL BE
PREPARED IN
ACCORDANCE w/
SECTION R703.8.2.1
OF THE 2018 NCR

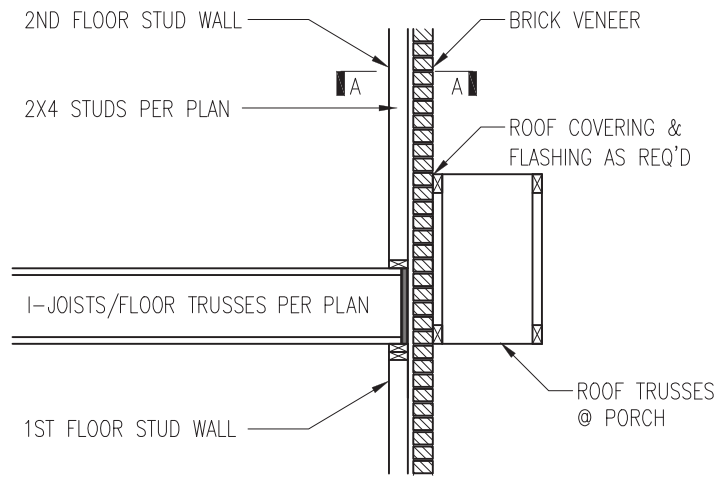

TRUSSES PERPENDICULAR TO STUD WALL

TRUSSES PARALLEL TO STUD WALL
w/ CONTINUOUS BRICK VENEER

1 BRICK SUPPORT ABOVE STORAGE/PORCH ROOF DETAIL
D5f NTS

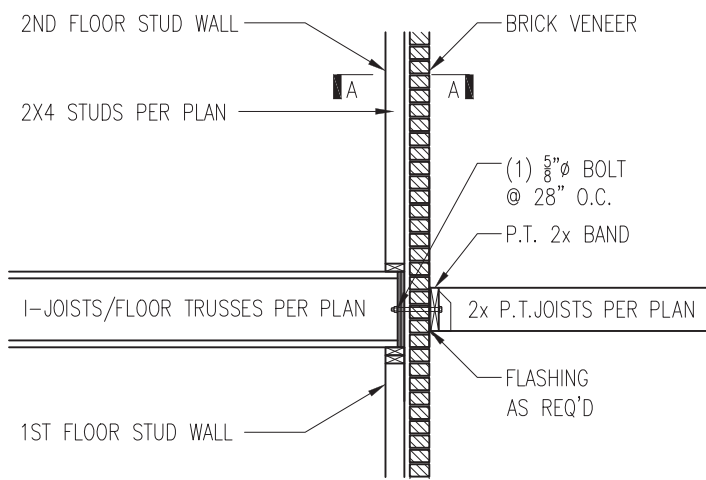

3 BALCONY JOIST ATTACHMENT
D5f NTS

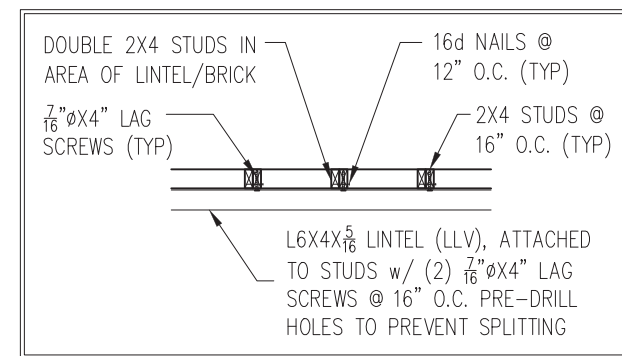

SECTION A-A
NTS

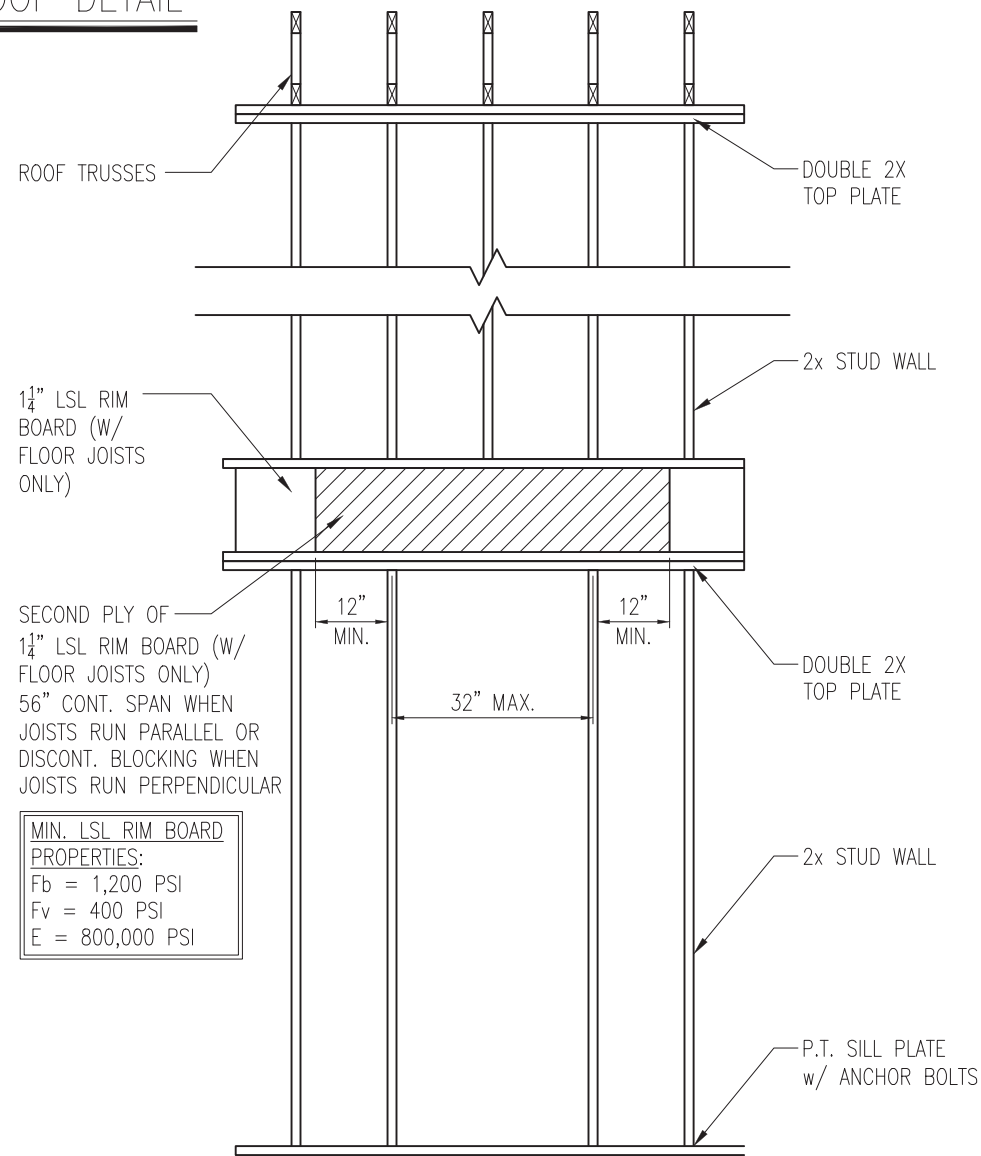

SECOND PLY OF
1 1/4\"/>

MIN. LSL RIM BOARD
PROPERTIES:
Fb = 1,200 PSI
Fv = 400 PSI
E = 800,000 PSI

4 TYP. RANGE VENT FRAMING
D5f VENTED TO EXTERIOR WALL



STRUCTURAL MEMBERS ONLY

SUMMIT
ENGINEERING LABORATORY TESTING
3070 HAMMOND BUSINESS PLACE,
SUITE 171, RALEIGH, NC 27603
OFFICE: 919.380.9991
FAX: 919.380.9993
WWW.SUMMIT-COMPANIES.COM

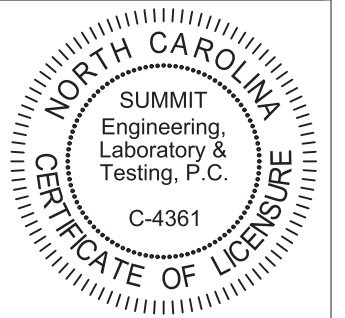

PROJECT
Standard Details
Framing Details
CLIENT
Smith Douglas Homes
110 Village Trail, Suite 215
Woodstock, GA 30188

CURRENT DRAWING
DATE: 2/18/20
SCALE: NTS
PROJECT #: 3832
DRAWN BY: LBV
CHECKED BY: WAJ

ORIGINAL DRAWING
NO. DATE PROJECT #
0 1/7/16 3832

REFER TO COVER SHEET FOR A
COMPLETE LIST OF REVISIONS

SHEET
D5f

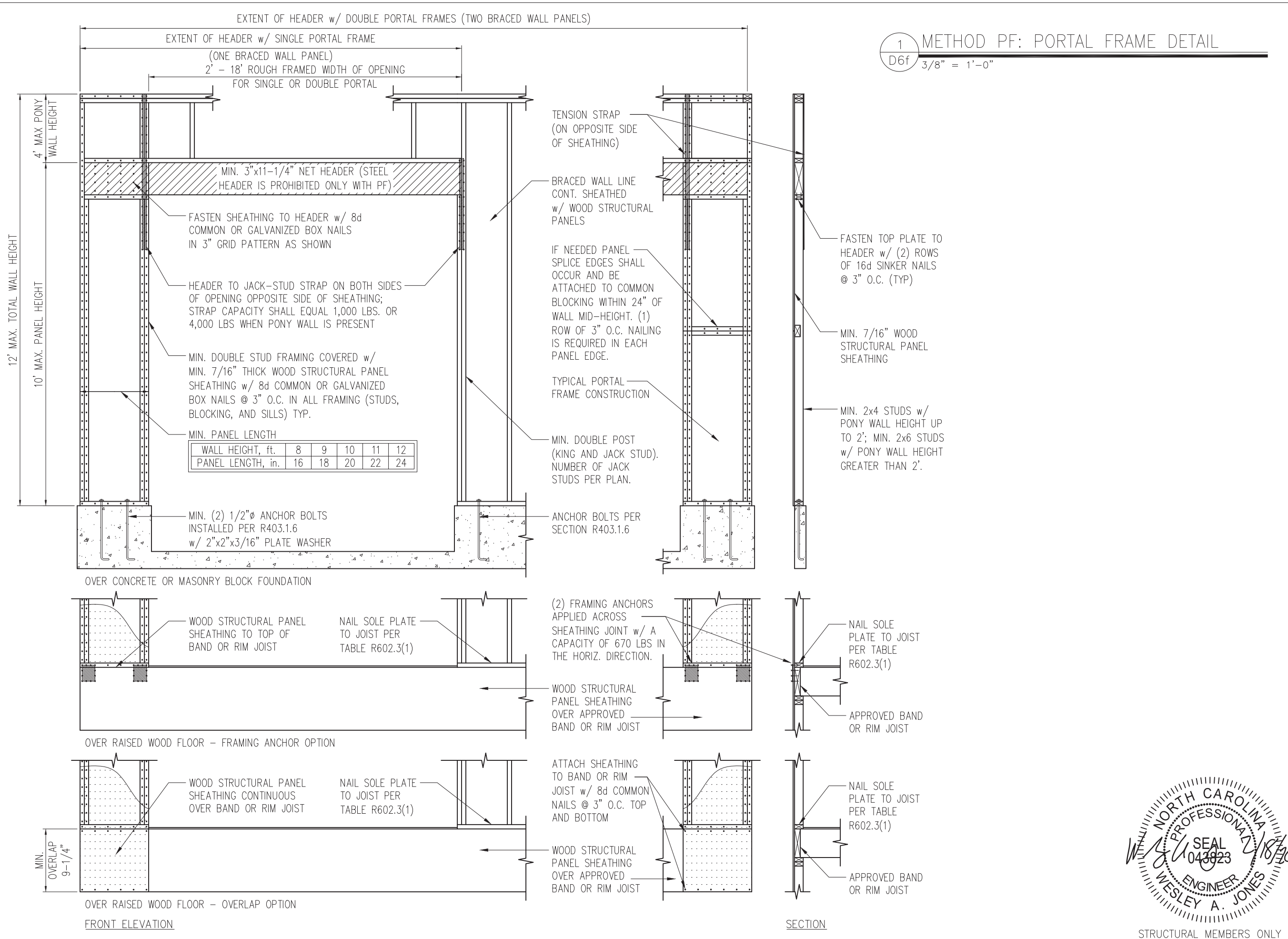

1 METHOD PF: PORTAL FRAME DETAIL
 D6f 3/8" = 1'-0"

SUMMIT
 ENGINEERING LABORATORY TESTING
 3070 HAMMOND BUSINESS PLACE,
 SUITE 171, RALEIGH, NC 27603
 OFFICE: 919.380.9991
 FAX: 919.380.9993
 WWW.SUMMIT-COMPANIES.COM

NORTH CAROLINA
 SUMMIT
 Engineering,
 Laboratory &
 Testing, P.C.
 C-4361
 CERTIFICATE OF LICENSURE

PROJECT
Standard Details
Framing Details - Bracing

CLIENT
Smith Douglas Homes
110 Village Trail, Suite 215
Woodstock, GA 30188

CURRENT DRAWING
 DATE: 2/18/20
 SCALE: NTS
 PROJECT #: 3832
 DRAWN BY: LBV
 CHECKED BY: WAJ

ORIGINAL DRAWING
 NO. DATE PROJECT #
 0 1/7/16 3832

REFER TO COVER SHEET FOR A COMPLETE LIST OF REVISIONS

NORTH CAROLINA
 PROFESSIONAL ENGINEER
 SEAL
 043823
 WESLEY A. JONES

SHEET
D6f
 STRUCTURAL MEMBERS ONLY

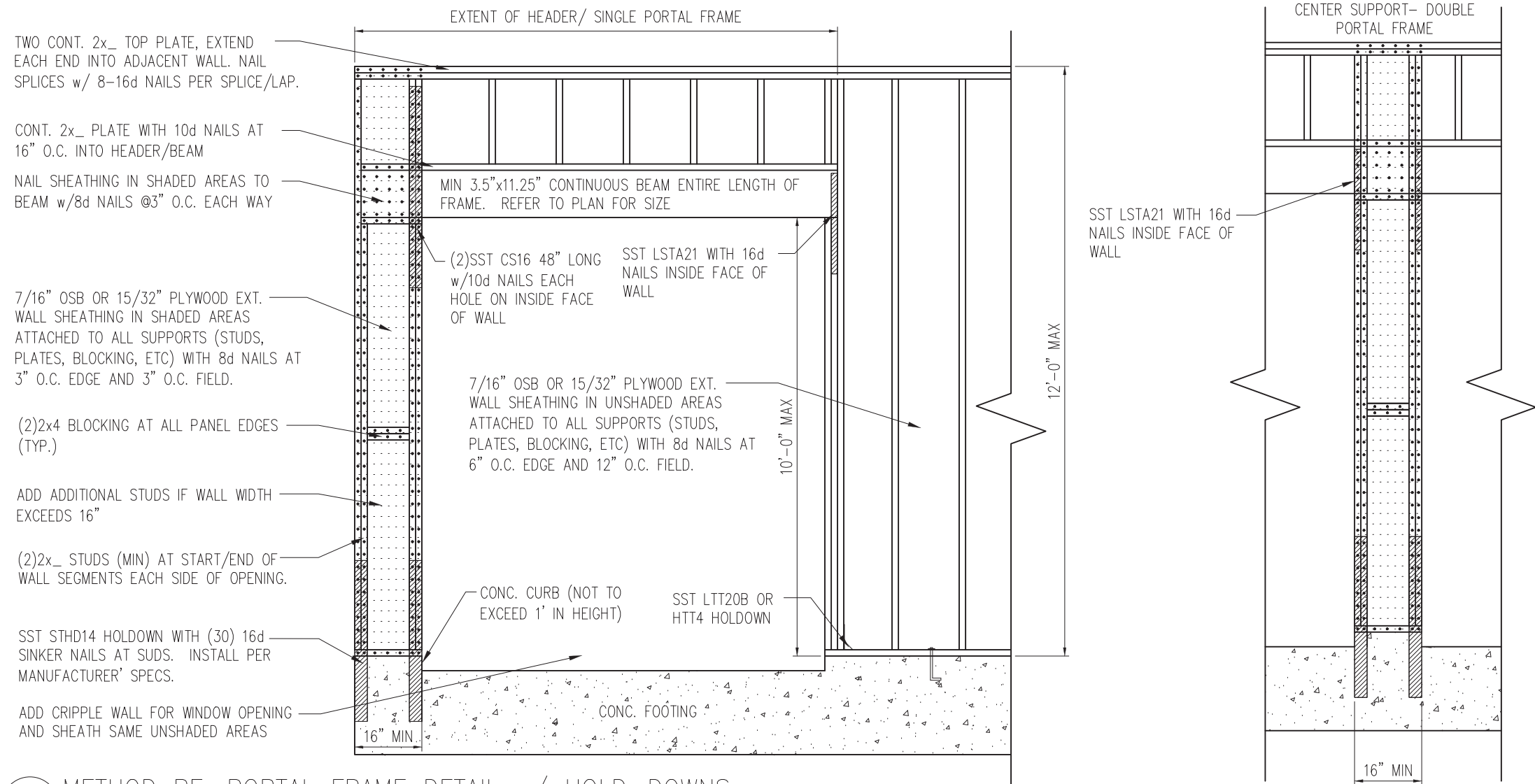

1 METHOD PF: PORTAL FRAME DETAIL w/ HOLD-DOWNS
 D7f 3/4" = 1'-0"

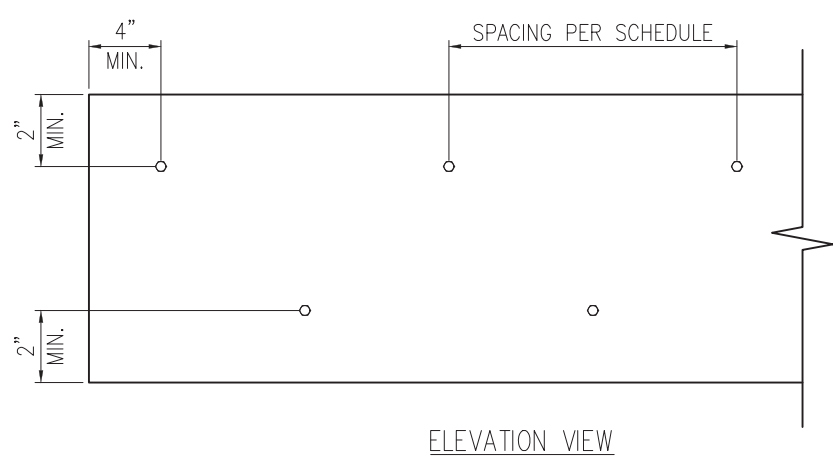

2 MULTI-PLY BEAM CONNECTION DETAIL
 D7f N.T.S

MINIMUM FASTENING REQUIREMENTS FOR TOP- AND SIDE-LOADED MEMBERS

FASTENER TYPE	LVL DEPTH	3/4" WIDE		5/4" WIDE		7" WIDE	
		2-Ply 1 3/4"	3-Ply 1 3/4"	1 3/4" + 3 1/2"	4-Ply 1 3/4"	2-Ply 1 3/4" + 3 1/2"	2-Ply 3 1/2"
10d (0.128" x 3") Nails	7 1/4" ≤ d < 14"	3 rows @ 12" o.c.	3 rows @ 12" o.c. (ES)	3 rows @ 12" o.c.	-	3 rows @ 12" o.c. (ES)	-
	d ≥ 14"	4 rows @ 12" o.c.	4 rows @ 12" o.c. (ES)	4 rows @ 12" o.c.	-	4 rows @ 12" o.c. (ES)	-
16d (0.162" x 3 1/2") Nails	7 1/4" ≤ d < 14"	2 rows @ 12" o.c.	2 rows @ 12" o.c. (ES)	2 rows @ 12" o.c.	-	2 rows @ 12" o.c. (ES)	-
	d ≥ 14"	3 rows @ 12" o.c.	3 rows @ 12" o.c. (ES)	3 rows @ 12" o.c.	-	3 rows @ 12" o.c. (ES)	-
1/2" Through Bolts	d ≥ 7 1/4"	2 rows @ 24" o.c.	2 rows @ 24" o.c.		2 rows @ 24" o.c.		-
SDS 1/4" x 3 1/2", WS35, 3 3/8" TrussLok		2 rows @ 24" o.c.	2 rows @ 24" o.c. (ES)	2 rows @ 24" o.c.	-	2 rows @ 24" o.c. (ES)	-
SDS 1/4" x 6", WS6		-	-	-	2 rows @ 24" o.c. (ES)		-
5" TrussLok		-	2 rows @ 24" o.c.		-		-
6 3/4" TrussLok		-	-	-	2 rows @ 24" o.c.		-

NOTES:

- All fasteners must meet the minimum requirements in the table above. Side-loaded multiple-ply members must meet the minimum fastening and side-loading capacity requirements given on page 48.
- Minimum fastening requirements for depths less than 7 1/4" require special consideration. Please contact your technical representative.
- Three general rules for staggering or offsetting for a certain fastener schedule:
 - If staggering or offsetting is not referenced, then none is required;
 - If staggering is referenced, then fasteners installed in adjacent rows on the front side are to be staggered up to one-half the o.c. spacing, but maintaining the fastener clearances above; and
 - If "ES" is referenced, then the fastener schedule must be repeated on each side, with the fasteners on the back side offset up to one-half the o.c. spacing of the front side (whether or not it is staggered).

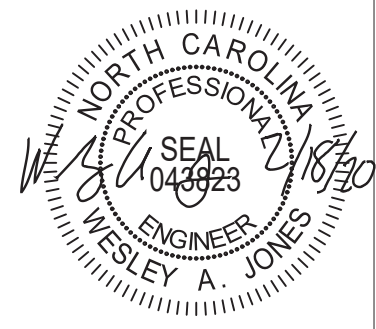

STRUCTURAL MEMBERS ONLY

SUMMIT
 ENGINEERING LABORATORY TESTING
 3070 HAMMOND BUSINESS PLACE,
 SUITE 171, RALEIGH, NC 27603
 OFFICE: 919.380.9991
 FAX: 919.380.9993
 WWW.SUMMIT-COMPANIES.COM

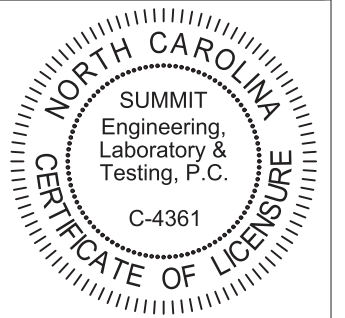

PROJECT
 Standard Details
 Framing Details - Bracing
 CLIENT
 Smith Douglas Homes
 110 Village Trail, Suite 215
 Woodstock, GA 30188

CURRENT DRAWING
 DATE: 2/18/20
 SCALE: NTS
 PROJECT #: 3832
 DRAWN BY: LBV
 CHECKED BY: WAJ
 ORIGINAL DRAWING
 NO. DATE PROJECT #
 0 1/7/16 3832

REFER TO COVER SHEET FOR A COMPLETE LIST OF REVISIONS

SHEET
D7f

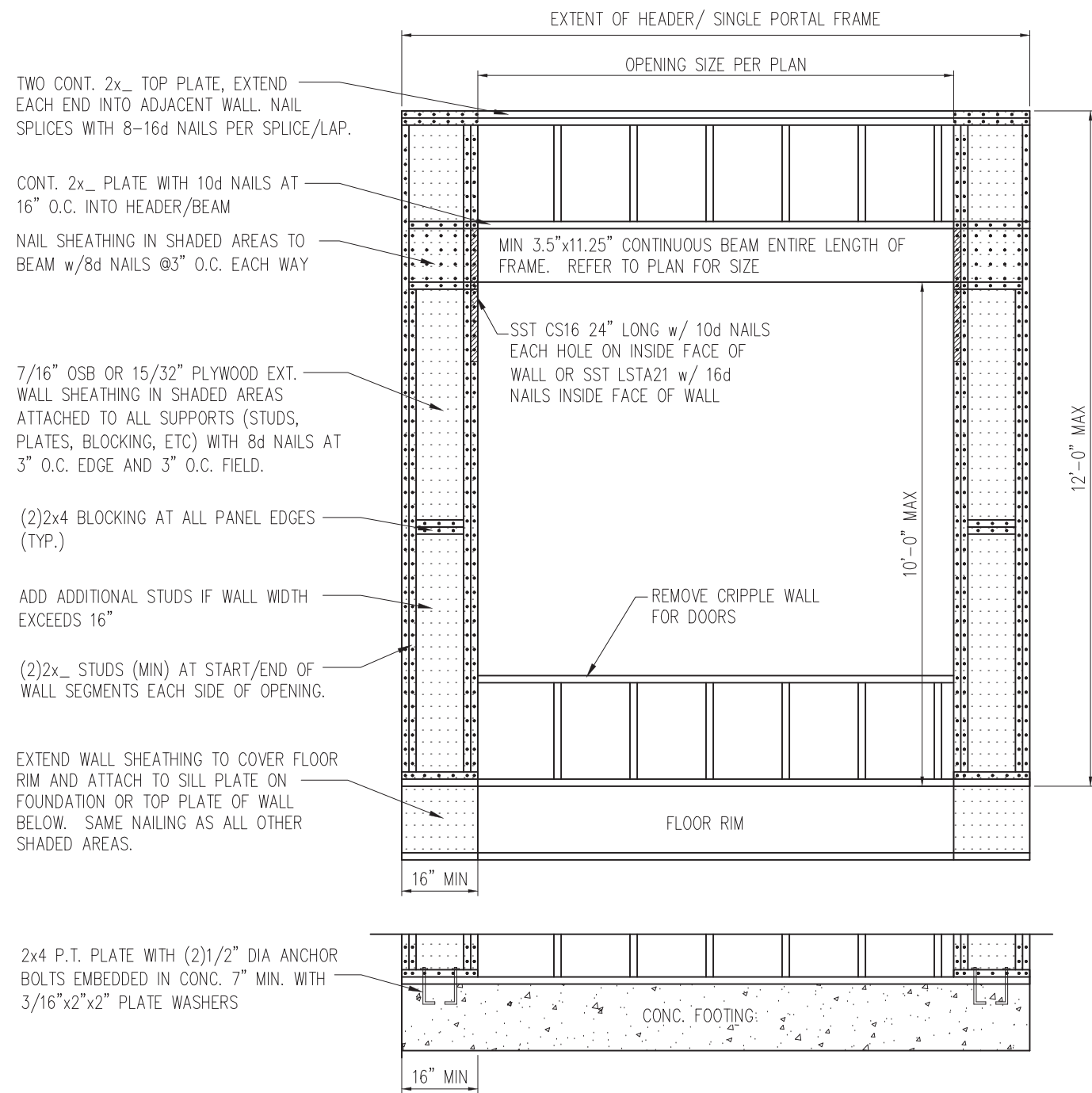

1 METHOD PF: PORTAL FRAME DETAIL
 D8f 3/4" = 1'-0" OPENINGS UNDER 8'-0"

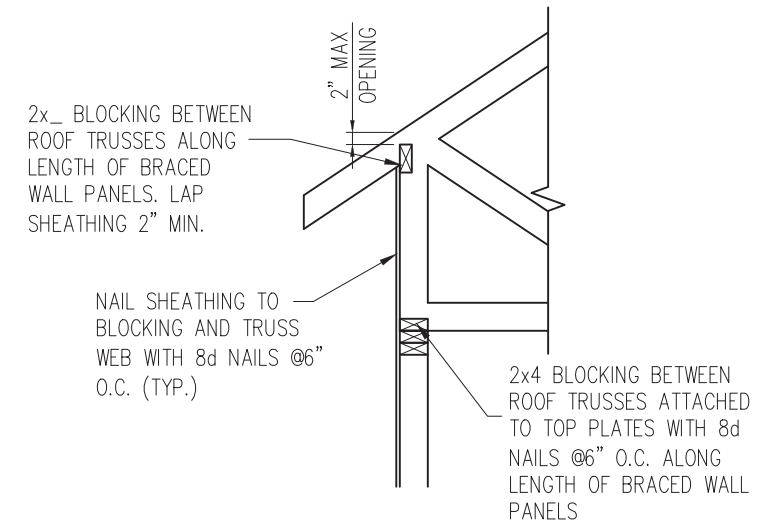

HEEL HEIGHT GREATER THAN 15.25"

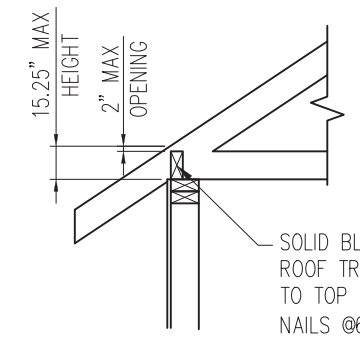

HEEL HEIGHT LESS THAN 15.25" *

*BLOCKING IS NOT REQUIRED WITH HEEL HEIGHTS LESS THAN 9.25"

2 TYP. WALL PANEL TO ROOF TRUSS CONNECTION
 D8f 1" = 1'-0"



STRUCTURAL MEMBERS ONLY

SUMMIT
 ENGINEERING LABORATORY TESTING
 3070 HAMMOND BUSINESS PLACE,
 SUITE 171, RALEIGH, NC 27603
 OFFICE: 919.380.9991
 FAX: 919.380.9993
 WWW.SUMMIT-COMPANIES.COM

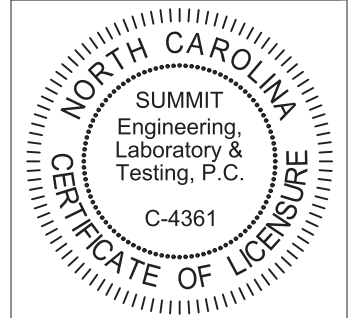

PROJECT
Standard Details - Bracing
Framing Details - Bracing
 CLIENT
Smith Douglas Homes
110 Village Trail, Suite 215
Woodstock, GA 30188

CURRENT DRAWING
 DATE: 2/18/20
 SCALE: NTS
 PROJECT #: 3832
 DRAWN BY: LBV
 CHECKED BY: WAJ

ORIGINAL DRAWING
 NO. DATE PROJECT #
 0 1/7/16 3832

REFER TO COVER SHEET FOR A COMPLETE LIST OF REVISIONS

SHEET
D8f

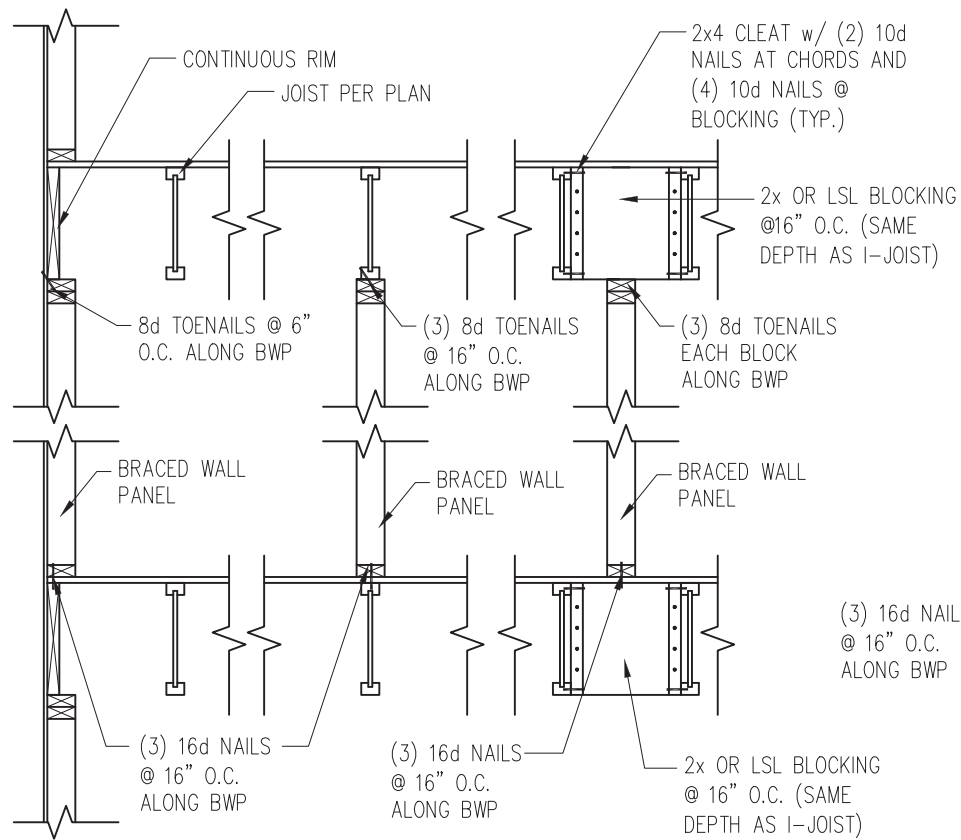

JOISTS PARALLEL TO BRACED WALLS

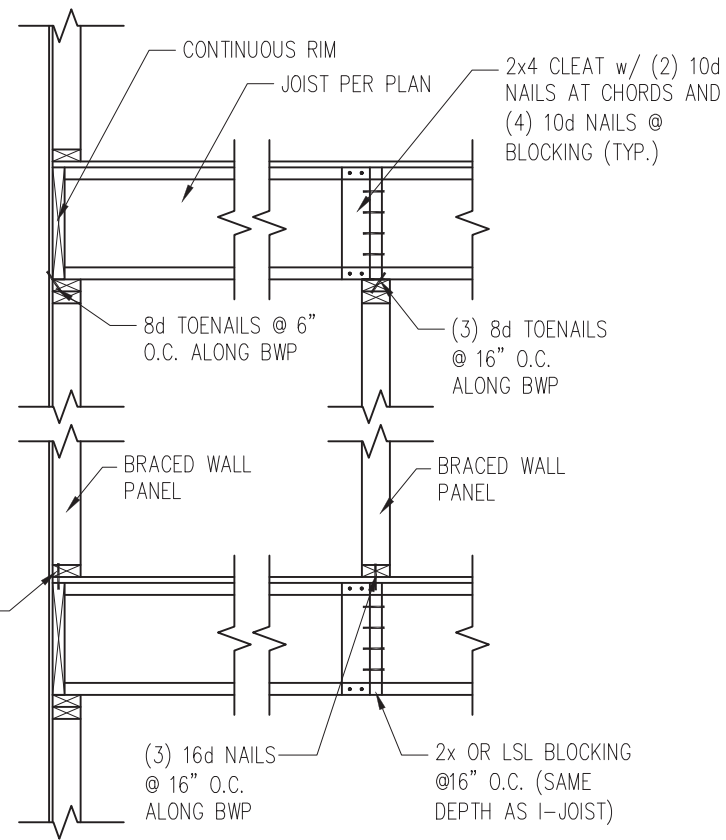

JOISTS PERPENDICULAR TO BRACED WALLS

1 TYP. WALL PANEL TO FLOOR/CEILING CONNECTION
D9f 1" = 1'-0"

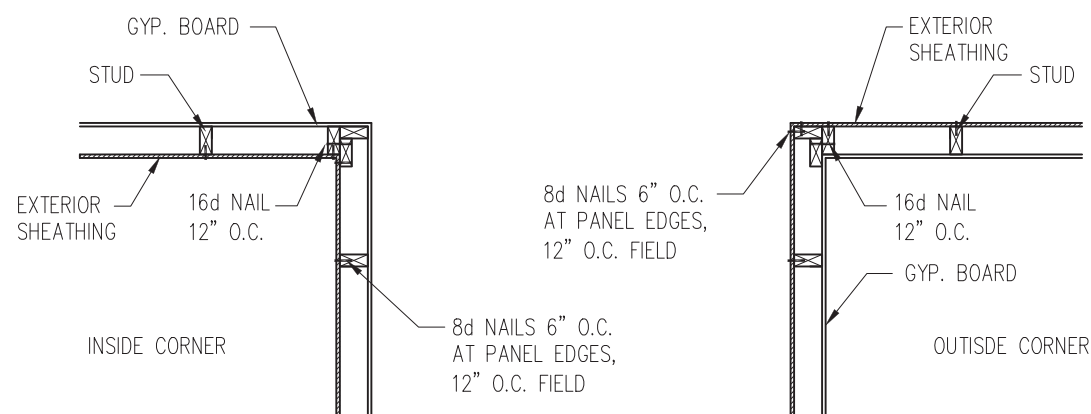

2 TYP. EXTERIOR CORNER FRAMING
D9f 1" = 1'-0"

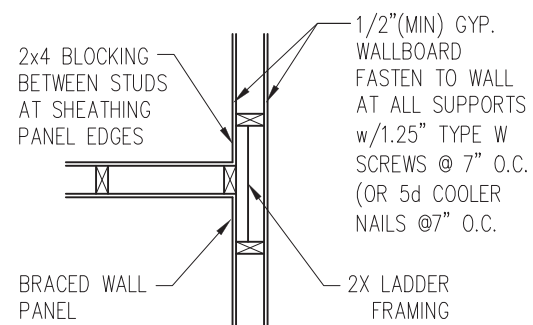

3 INTERIOR 3-STUD WALL INTERSECTION
D9f 1" = 1'-0"

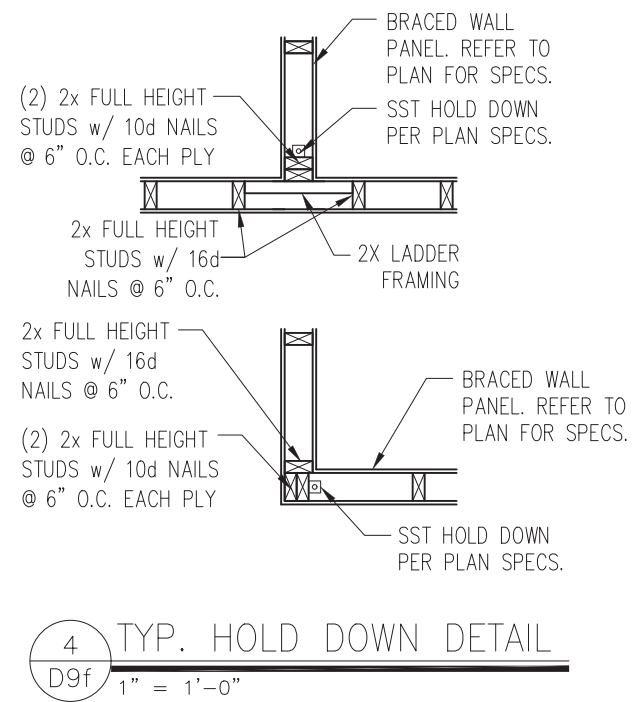

4 TYP. HOLD DOWN DETAIL
D9f 1" = 1'-0"



STRUCTURAL MEMBERS ONLY

SUMMIT
ENGINEERING LABORATORY TESTING
3070 HAMMOND BUSINESS PLACE,
SUITE 171, RALEIGH, NC 27603
OFFICE: 919.380.9991
FAX: 919.380.9993
WWW.SUMMIT-COMPANIES.COM

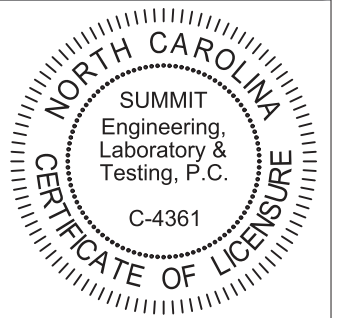

PROJECT
Standard Details
Framing Details - Bracing
CLIENT
Smith Douglas Homes
110 Village Trail, Suite 215
Woodstock, GA 30188

CURRENT DRAWING
DATE: 2/18/20
SCALE: NTS
PROJECT #: 3832
DRAWN BY: LBV
CHECKED BY: WAJ

ORIGINAL DRAWING
NO. DATE PROJECT #
0 1/7/16 3832

REFER TO COVER SHEET FOR A COMPLETE LIST OF REVISIONS

SHEET
D9f

TRUSS TO WALL CONNECTIONS, IF SHOWN, ARE FOR UPLIFT ONLY AND DO NOT CONSIDER LATERAL LOADS. ALL CONNECTORS ON THIS PROJECT ARE TO BE INSTALLED PER THE CONNECTOR MANUFACTURER'S SPECIFICATIONS. ALL CONNECTORS SHOWN THAT ARE NOT "TRUSS TO TRUSS" ARE SUGGESTIONS ONLY AND ARE TO BE VERIFIED BY THE BUILDING DESIGNER OR ENGINEER OF RECORD FOR SUITABILITY TO THIS PARTICULAR PROJECT. UFP MID-ATLANTIC, LLC. ACCEPTS NO RESPONSIBILITY FOR THE SPECIFIC APPLICATION OR SUITABILITY OF ANY CONNECTOR THAT IS NOT "TRUSS TO TRUSS" AS THEY APPLY TO THIS SPECIFIC STRUCTURE.

TELFAIR ADG W/2nd FLOOR

37	FACE MOUNT HANGER	HUS26	A
----	-------------------	-------	---

Wall Height 8' 6 5/8"

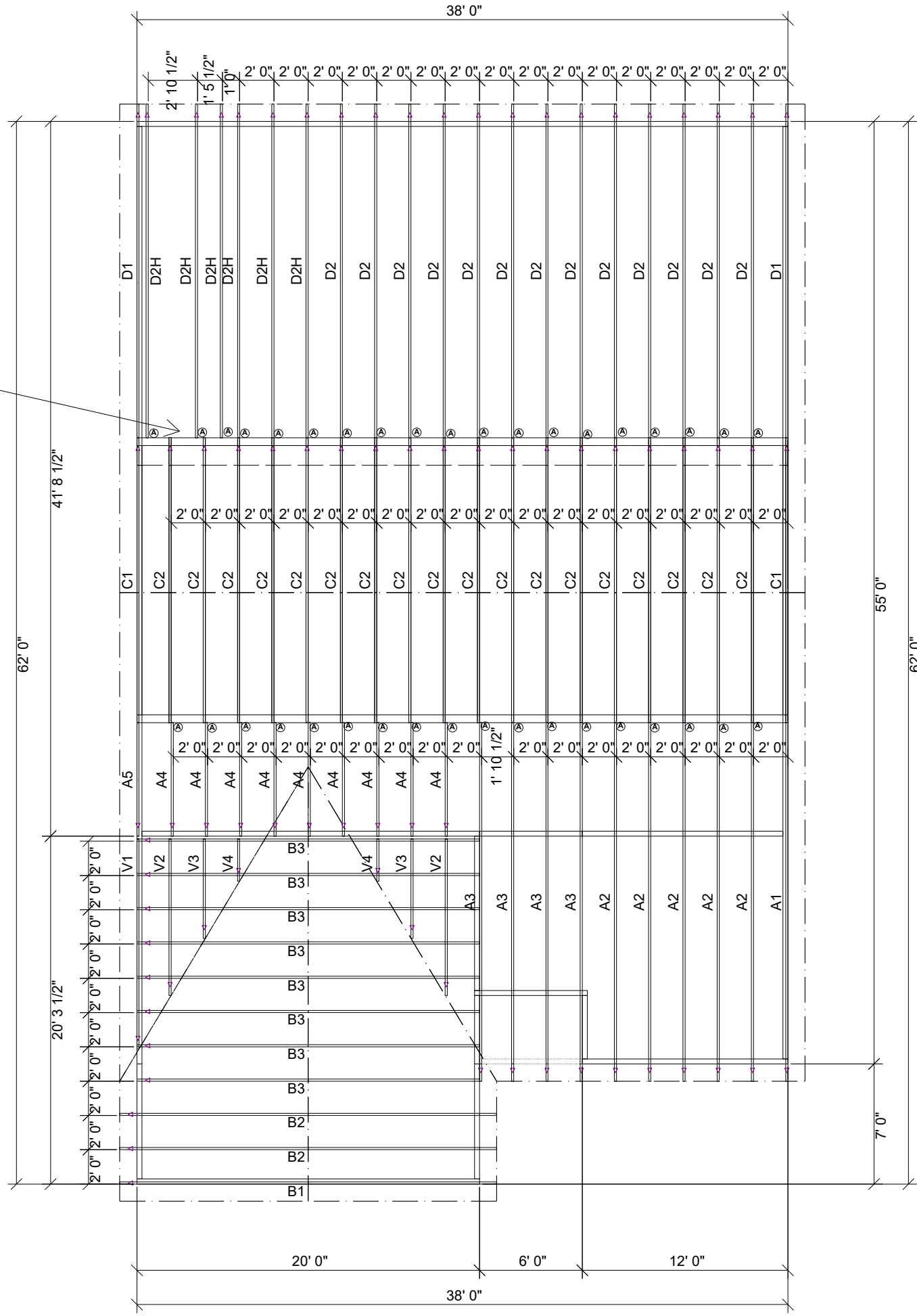

ROOF AREA: 2786.62 ft² _ RIDGE LINE: 65.33 ft _ VALLEY LINES: 46.52 _ HIP LINES: 0 _ Indicates Left End of Truss

CUSTOMER	
SMITH DOUGLAS	
Job Name	TELFAIR ADG
Drawn By: BSC	Quality Products for Quality Builders
Date: 12-19-19	Scale: NTS
Revision Date1:	Revision Date2:
Quote Number	
MASTER	

NOTES: THIS DRAWING IS THE PROPERTY OF UFP MID-ATLANTIC, LLC. IT IS TO BE USED ONLY FOR THE PROJECT AND SITE SPECIFICALLY IDENTIFIED TO THE INTEREST OF UFP MID-ATLANTIC, LLC. THIS DRAWING MUST BE USED IN CONJUNCTION WITH ALL OTHER TECHNICAL DRAWINGS SUPPLIED BY UFP MID-ATLANTIC, LLC AND BRACING WOOD TRUSSES, COMMENTARY AND RECOMMENDATIONS AS PUBLISHED BY THE MANUFACTURER'S LITERATURE. TRUSSES (FPI) IS LOCATED AT 683 D CONFRID DR. SUITE 200 MADISON, VA 155719 (603) 833-5600

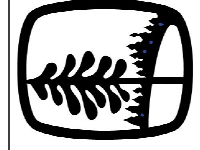

UFP MID-ATLANTIC, LLC
A UNIVERSAL FOREST PRODUCTS COMPANY
BURLINGTON, NC PHONE (800) 476-9356
CHESAPEAKE, VA PHONE (800) 476-3190
CONWAY, SC PHONE (800) 397-9572
JEFFERSON GA PHONE (800) 648-4038
PEARISBURG, VA PHONE (800) 397-9571

1. TEMPORARY BRACING TO BE INSTALLED w/T.P.I. STANDARD BC51-B1.
2. SEE ENGINEERED DRAWING FOR PERMANENT BRACING MINIMUM REQUIREMENTS.
3. FRAMER TO VERIFY ALL DIMENSIONS, DROP, & TRUSS PLACEMENT PRIOR TO TRUSS PLACEMENT.
4. BLDG/FRAMER RESPONSIBLE FOR ADJUSTMENT OF TRUSS SPACING TO MISS PLUMBING DROPS, UNLESS NOTED OTHERWISE.
This layout is not an engineered drawing. This drawing was created to establish truss placement only. It is the responsibility of the builder to provide adequate support for all the elements shown in this drawing.

THIS IS AN ENGINEERED WOOD PRODUCT (EWP) MEMBER PLACEMENT DIAGRAM ONLY; NOT AN ENGINEERED DOCUMENT. EWP members are designed as individual building components to be incorporated into the building design at the specification of the building designer. The Contractor is responsible for the temporary bracing of the floor system, and the building designer is responsible for the permanent bracing and blocking of the floor system and the overall structure. The design of the support structure including but not limited to headers, beams, walls, and columns is also the responsibility of the building designer. It is the responsibility of the General Contractor to verify that the provided layout matches the final intended construction plans, loading conditions, and use. If they do not, it is the responsibility of the General Contractor to notify UFP and provide plans containing the latest specifications and designs. UFP will not be responsible for plan changes by others after final approval of shop drawings, or for errors or modifications made on-site during construction. DO NOT CUT, NOTCH, DRILL, OR OTHERWISE "REPAIR" EWP MEMBERS IN ANY WAY WITHOUT PRIOR WRITTEN AUTHORIZATION BY A LICENSED PROFESSIONAL DESIGNATED BY UFP. The Framers are responsible to verify all dimensions, including adjusting member spacing within tolerances to allow for the drop and rise of plumbing/HVAC, unless noted otherwise. All connectors on this project are to be installed per the connector manufacturer's specifications. All connectors shown that are not joist to joist are suggestions only and are to be verified by the Building Designer or Engineer of Record for suitability to this particular project. UFP accepts no responsibility for the specific application or suitability of any connector that is not joist to joist as they apply to this specific structure.

2ND FLOOR PLACEMENT PLAN

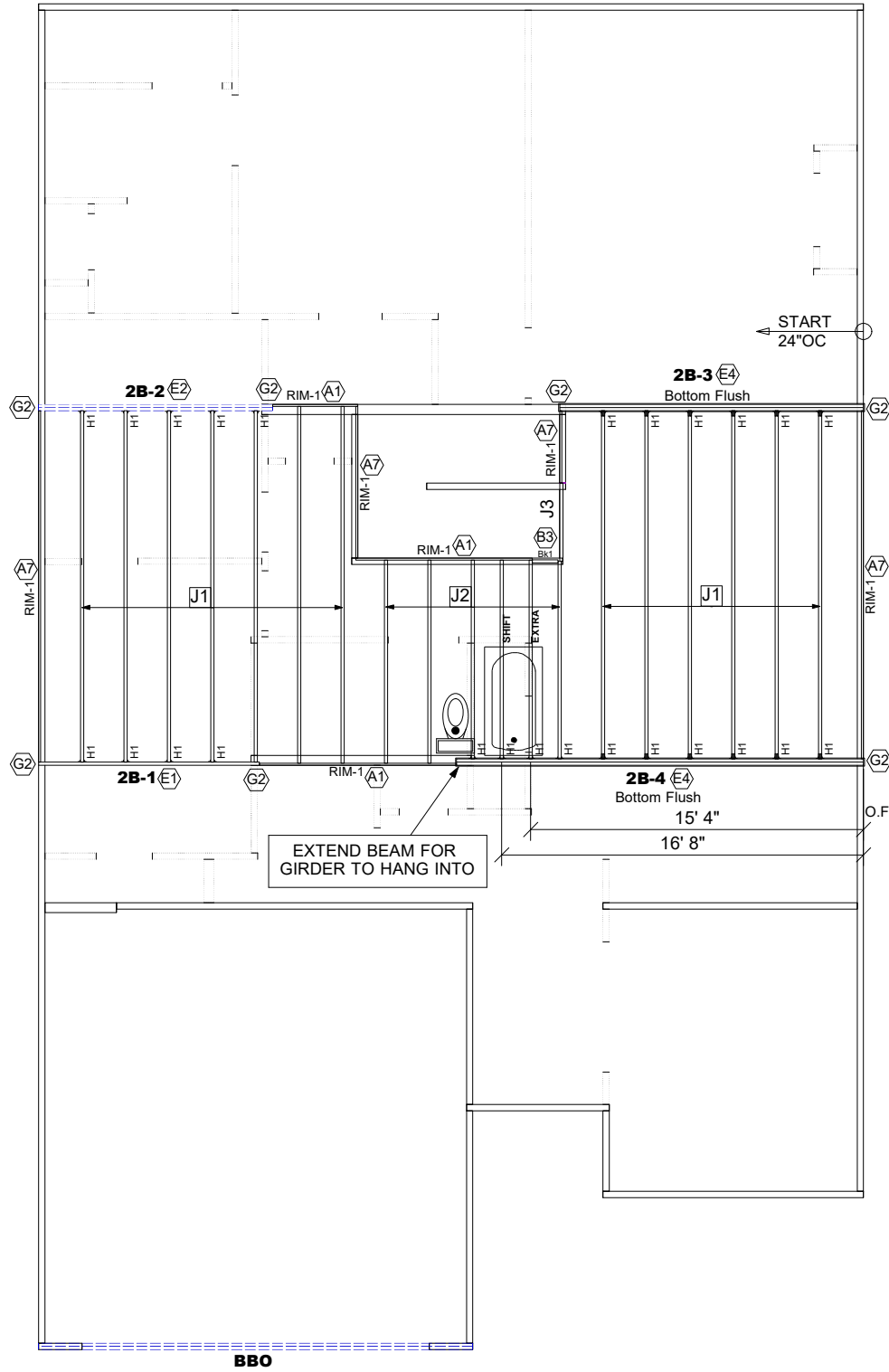
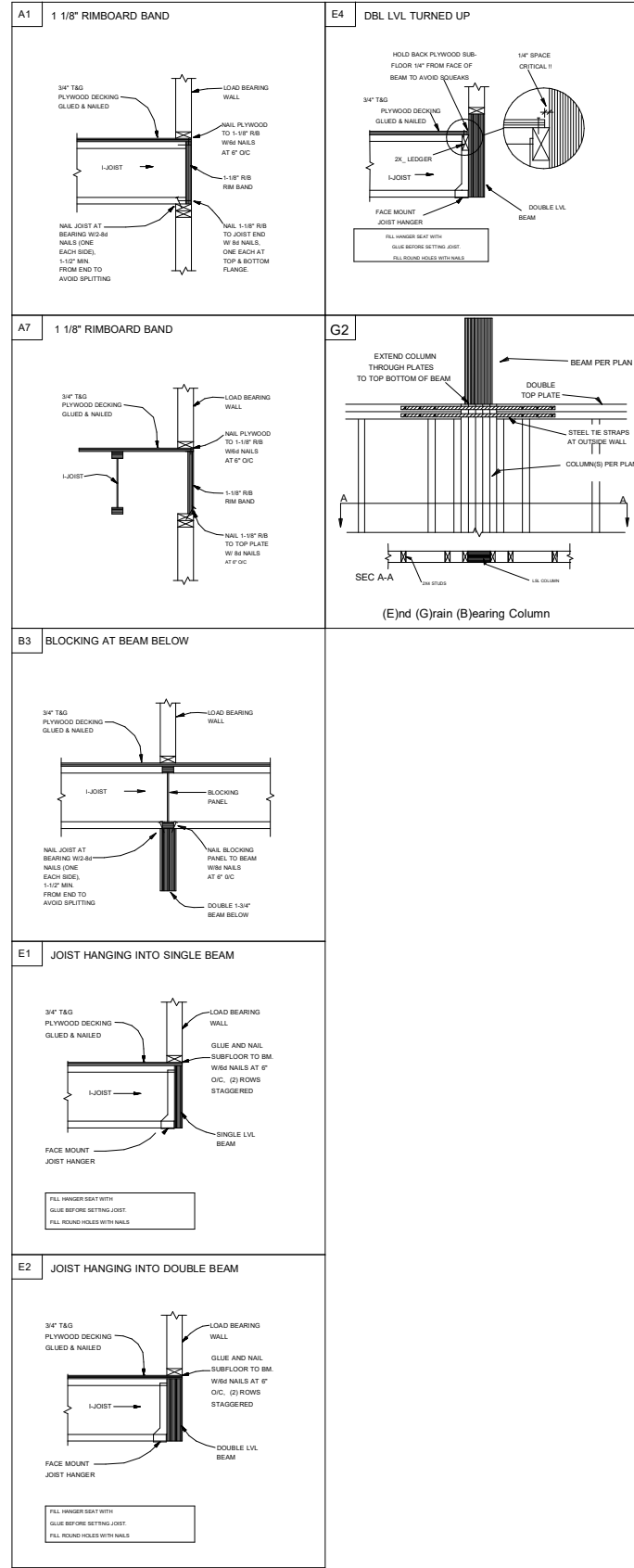

Products					
PlotID	Length	Product	Plies	Net Qty	Fab Type
J1	17' 0"	14" TJI@ 110	1	13	MFD
J2	10' 0"	14" TJI@ 110	1	6	MFD
J3	4' 0"	14" TJI@ 110	1	1	MFD
2B-1	11' 0"	1 3/4" x 14" 2.0E Microllam@ LVL	1	1	MFD
2B-2	11' 0"	1 3/4" x 14" 2.0E Microllam@ LVL	2	2	MFD
2B-3	14' 0"	1 3/4" x 16" 2.0E Microllam@ LVL	2	2	MFD
2B-4	19' 0"	1 3/4" x 24" 2.0E Microllam@ LVL	2	2	MFD
RIM-1	16' 0"	1 1/8" x 14" TJ@ Rim Board	1	4	FF
Bk1	2' 0"	14" TJI@ 110	1	1	MFD

Connector Summary			
PlotID	Qty	Manuf	Product
H1	25	MiTek	IHFL1714

• Avoid Plumbing Drops

FIELD LOCATE PLUMBING DROPS/CAN LIGHTS, ETC... PRIOR TO JOIST SECUREMENT TO AVOID INTERFERENCE.

LAYOUT FOR 19.2" O/C

1= 19-3/16"	9= 172-13/16"
2= 38-3/8"	10= 192"
3=57-5/8"	11= 211-3/16"
4= 76-13/16"	12= 230-3/8"
5= 96"	13= 249-13/16"
6= 115-3/16"	14= 268-13/16"
7= 134-3/8"	15= 288"
8= 153-5/8"	

FRAMER NOTE
 1. GLUE AND NAIL PLYWOOD SUBFLOOR TO BEAMS AND GIRDERS AT 6" O/C WHERE NO WALL IS ABOVE.
 2. FILL HANGER SEAT WITH GLUE BEFORE SETTING JOIST IN HANGER. FILL ROUND HOLES WITH NAILS.

CRITICAL !!
 INSTALL 2X4 SQUASH BLOCKS IN FLOOR TRUSS SPACE BELOW ALL EXTERIOR DOOR HEADER JACKS. CUT 1/16" TALLER THAN TRUSS.

FIELD VERIFY DIMENSIONS TO JOISTS LOCATED UNDER WALLS!!

2ND FLOOR LAYOUT

GENERAL NOTES:
 1.) TOP CHORD OF JOISTS ARE PAINTED RED AT NUMBERED END. PLACE PAINTED END AS NOTED ON PLAN.
 2.) FOLLOW SPECIAL SPACING AND LOCATION DIMENSIONS FOR EXTRAS OR SHIFTED JOISTS AS SHOWN ON PLAN.
 3.) ALL INTERIOR WALL PLATES MUST BE LEVEL WITH OUTSIDE WALL TOP PLATES.
 4.) DO NOT STACK CONSTRUCTION LOADS ON UN-BRACED JOISTS.
 5.) PROVIDE SOLID SUPPORT BELOW ALL BEAM AND HEADER BEARING POINTS IN WALL AND JOIST SPACES CONTINUOUS DOWN TO THE FOUNDATION.
 6.) LOCATE CRIPPLE STUDS IN JOIST SPACE DIRECTLY BELOW HEADER JACKS AT ALL FIRST FLOOR EXTERIOR DOOR LOCATIONS.
 7.) INSTALL NAILS IN ALL HOLES PROVIDED IN JOIST HANGERS EXCEPT AT BOTTOM CHORD SEAT. PLACE A DAB OF GLUE IN THE HANGER SEAT BEFORE SETTING JOISTS.
 8.) IMPORTANT NOTE! NO STRUCTURAL ANALYSIS OF CONVENTIONAL HEADERS HAS BEEN CONDUCTED IF NOT NOTED. THEY ARE CONSIDERED TO BE ADEQUATE TO SUPPORT THE APPLIED LOADS.

PLAN LEGEND

1B-, 2B-	*INDICATES BEAM ABOVE TOP PLATE (FLUSH WITH FLOOR SYSTEM)
H-, 1H-, GDH-	*INDICATES BEAM BELOW TOP PLATE (DROPPED BELOW FLOOR SYSTEM)
SHIFT	*BEAMS MAY PROTRUDE ABOVE OR BELOW DECKING OR TOP PLATE RESPECTIVELY. REFER TO DETAIL IF BEAM IS A DIFFERENT DEPTH THAN FLOOR SYSTEM
EXTRA	SINGLE PLY BEAM (ADD LINE FOR EACH ADDITIONAL PLY)
DOUBLE	SHIFTED JOIST TO MISS PLUMBING, ALIGN WALL OR SUPPORT FURNITURE
	A JOIST ADDED TO THE LAYOUT IN ADDITION TO THE ON-CENTER JOISTS
	TWO JOISTS SIDE BY SIDE (ONLY ASSEMBLED IF NOTED)

ALL DIMENSIONS TO CENTERLINE UNLESS OTHERWISE NOTED

REVISIONS	DESCRIPTION	DSN

DESIGNER PB2
 LAYOUT DATE 10/7/2024
 ARCH DATE 10/9/2023
 STRUC DATE 11/21/2022
 JOB #: 24100399F2

SCALE: 1/8"=1'

UFP SITE BUILT
 A UFP INDUSTRIES COMPANY

Burlington, NC
 Locust, NC
 Chesapeake, VA
 Liberty, NC
 Clinton, NC
 Ooltewah, TN
 Conway, SC
 Pearisburg, VA
 Jefferson, GA
 Stanfield, NC

Customer Service (800) 476-9356

This drawing is property of UFP Site Built, LLC. Any unauthorized use of this document without written permission is prohibited. UFP relinquishes ownership of delivered product upon delivery. Owner of product must obtain UFP's authorization prior to any alteration or modification of product. UFP will not be held responsible for any unauthorized modifications done or costs incurred without prior written authorization from UFP.

TRUSSTRAX
 UFP CONSTRUCTION

Smith Douglas Homes

Telfair 2nd Floor