

THIS IS AN ENGINEERED WOOD PRODUCT (EWP) MEMBER PLACEMENT DIAGRAM ONLY; NOT AN ENGINEERED DOCUMENT. EWP members are designed as individual building components to be incorporated into the building design at the specification of the building designer. The Contractor is responsible for the temporary bracing of the floor system, and the building designer is responsible for the permanent bracing and blocking of the floor system and the overall structure. The design of the support structure including but not limited to headers, beams, walls, and columns is also the responsibility of the building designer. It is the responsibility of the General Contractor to verify that the provided layout matches the final intended construction plans, loading conditions, and use. If they do not, it is the responsibility of the General Contractor to notify UFP and provide plans containing the latest specifications and designs. UFP will not be responsible for plan changes by others after final approval of shop drawings, or for errors or modifications made on-site during construction. DO NOT CUT, NOTCH, DRILL, OR OTHERWISE "REPAIR" EWP MEMBERS IN ANY WAY WITHOUT PRIOR WRITTEN AUTHORIZATION BY A LICENSED PROFESSIONAL DESIGNATED BY UFP. The Framing is responsible to verify all dimensions, including adjusting member spacing within tolerances to allow for the drop and rise of plumbing/HVAC, unless noted otherwise. All connectors on this project are to be installed per the connector manufacturer's specifications. All connectors shown that are not joist to joist are suggestions only and are to be verified by the Building Designer or Engineer of Record for suitability to this particular project. UFP accepts no responsibility for the specific application or suitability of any connector that is not joist to joist as they apply to this specific structure.

Products					
Fab Type	Net Qty	Plies	Product	Length	PlotID
MFD	19	1	11 7/8" TJI@ 210	28' 0"	J1
MFD	2	1	11 7/8" TJI@ 210	16' 0"	J2
MFD	3	1	11 7/8" TJI@ 210	13' 0"	J3
MFD	7	1	11 7/8" TJI@ 210	12' 0"	J4
MFD	12	1	11 7/8" TJI@ 210	9' 0"	J5
MFD	2	2	1 3/4" x 11 7/8" 2.OE Microllam@ LVL	19' 0"	1B-1
FF	12	1	1 1/8" x 11 7/8" TJI@ Rim Board	16' 0"	RIM-1
MFD	14	1	11 7/8" TJI@ 210	2' 0"	Bk1

GENERAL NOTES:

- 1.) TOP CHORD OF JOISTS ARE PAINTED RED AT NUMBERED END. PLACE PAINTED END AS NOTED ON PLAN.
- 2.) FOLLOW SPECIAL SPACING AND LOCATION DIMENSIONS FOR EXTRAS OR SHIFTED JOISTS AS SHOWN ON PLAN.
- 3.) ALL INTERIOR WALL PLATES MUST BE LEVEL WITH OUTSIDE WALL TOP PLATES.
- 4.) DO NOT STACK CONSTRUCTION LOADS ON UN-BRACED JOISTS.
- 5.) PROVIDE SOLID SUPPORT BELOW ALL BEAM AND HEADER BEARING POINTS IN WALL AND JOIST SPACES CONTINUOUS DOWN TO THE FOUNDATION.
- 6.) LOCATE CRIPPLE STUDS IN JOIST SPACE DIRECTLY BELOW HEADER JACKS AT ALL FIRST FLOOR EXTERIOR DOOR LOCATIONS.
- 7.) INSTALL NAILS IN ALL HOLES PROVIDED IN JOIST HANGERS EXCEPT AT BOTTOM CHORD SEAT. PLACE A DAB OF GLUE IN THE HANGER SEAT BEFORE SETTING JOISTS.
- 8.) IMPORTANT NOTE! NO STRUCTURAL ANALYSIS OF CONVENTIONAL HEADERS HAS BEEN CONDUCTED IF NOT NOTED. THEY ARE CONSIDERED TO BE ADEQUATE TO SUPPORT THE APPLIED LOADS.

PLAN LEGEND

- INDICATES BEAM ABOVE TOP PLATE (FLUSH WITH FLOOR SYSTEM)
- INDICATES BEAM BELOW TOP PLATE (CROPPED BELOW FLOOR SYSTEM)
- BEAMS MAY PROTRUDE ABOVE OR BELOW DECKING OR TOP PLATE RESPECTIVELY, REFER TO DETAIL IF BEAM IS A DIFFERENT DEPTH THAN FLOOR SYSTEM
- SINGLE PLY BEAM ADD LINE FOR EACH ADDITIONAL PLY
- SHIFT JOIST TO MISS PLUMBING, ALIGN WITH WALL OR SUPPORT FURNITURE
- JOIST ADDED TO THE LAYOUT IN ADDITION TO THE ON-CENTER JOISTS
- TWO JOISTS SIDE BY SIDE (ONLY ASSEMBLED IF NOTED)

FRAMER NOTE

1. GLUE AND NAIL PLYWOOD SUBFLOOR TO BEAMS AND GIRDERS AT 6" O/C WHERE NO WALL IS ABOVE.
2. FILL HANGER SEAT WITH GLUE BEFORE SETTING JOIST IN HANGER. FILL ROUND HOLES WITH NAILS.

CRITICAL !!

- INSTALL 2X4 SQUASH BLOCKS IN FLOOR TRUSS SPACE BELOW ALL EXTERIOR DOOR HEADER JACKS. CUT 1/16" TALLER THAN TRUSS.

FIELD VERIFY DIMENSIONS TO JOISTS LOCATED UNDER WALLS!!

Avoid Plumbing Drops •

FIELD LOCATE PLUMBING DROPS/CAN LIGHTS, ETC... PRIOR TO JOIST SECUREMENT TO AVOID INTERFERENCE.

LAYOUT FOR 19.2" O/C

9= 172-13/16"	1= 19-3/16"
10= 192"	2= 38-3/8"
11= 211-3/16"	3= 57-5/8"
12= 230-3/8"	4= 76-13/16"
13= 249-13/16"	5= 96"
14= 268-13/16"	6= 115-3/16"
15= 288"	7= 134-3/8"
	8= 153-5/8"

1ST FLOOR LAYOUT

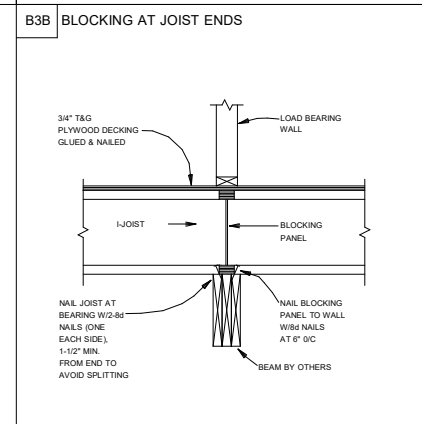
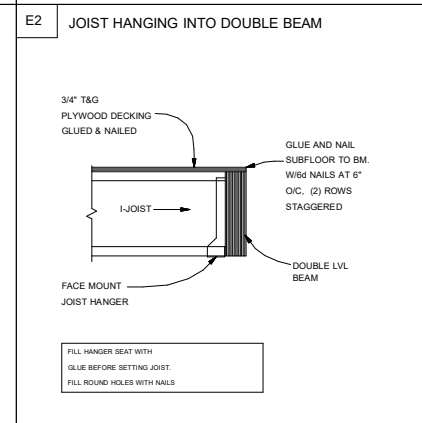
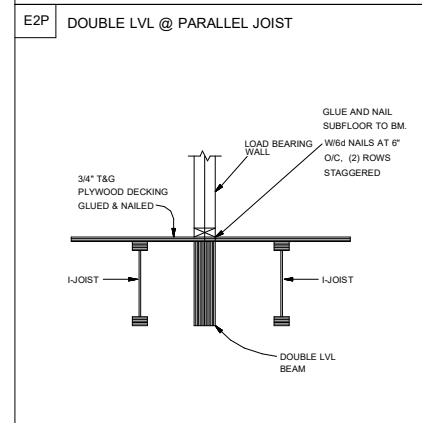
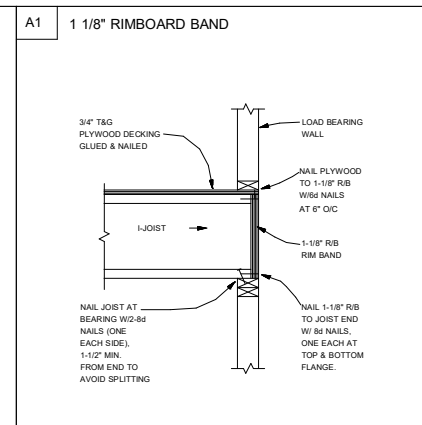
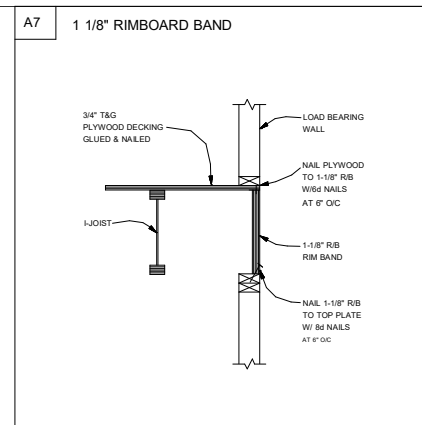
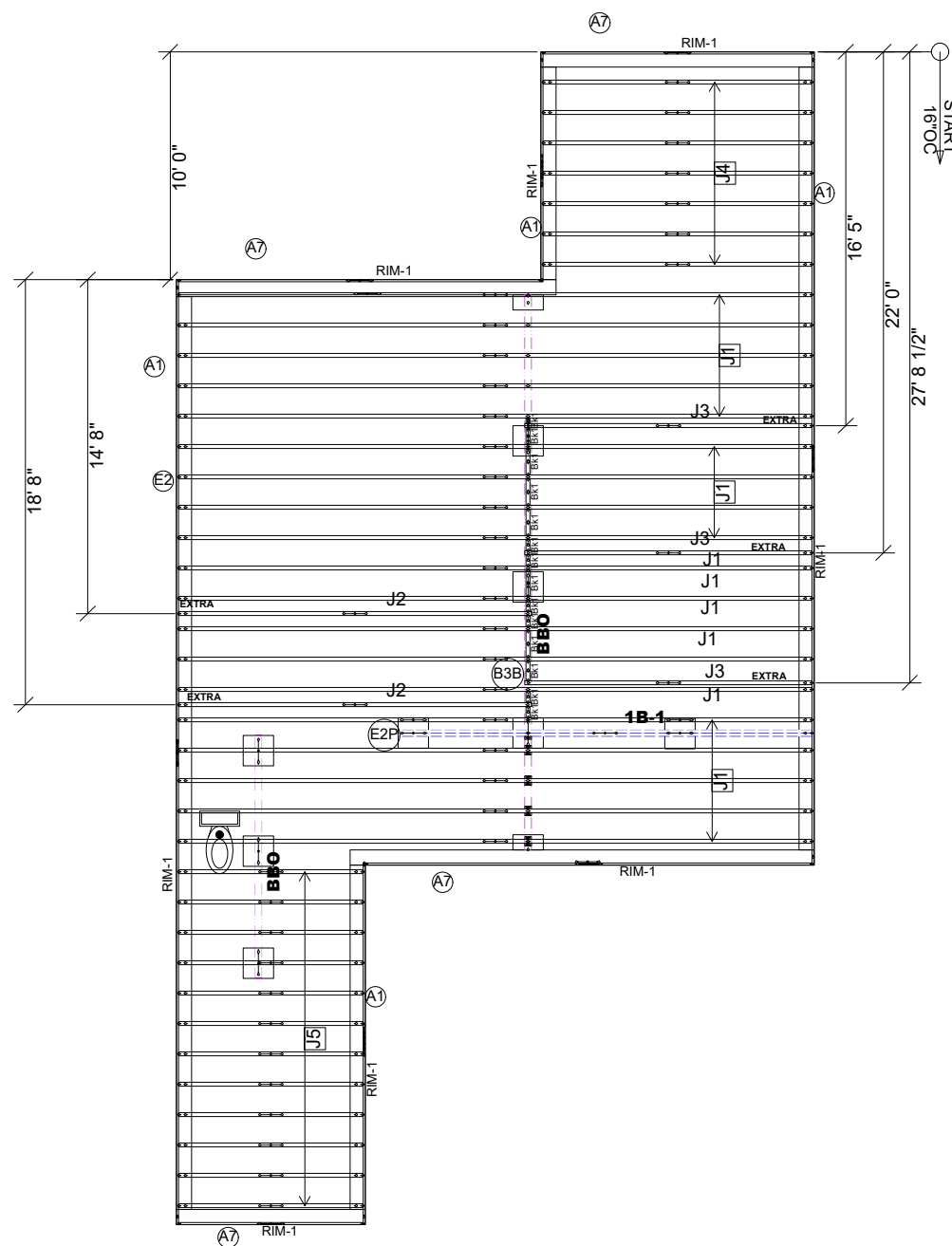

FLOOR PLACEMENT PLAN

SCALE: 1/8"=1'



This drawing is property of UFP Site Built, LLC. Any unauthorized use of this document without written permission is prohibited. UFP relinquishes ownership of delivered product upon delivery. Owner of product must obtain UFP's authorization prior to any alteration or modification of product. UFP will not be held responsible for any unauthorized modifications done or costs incurred without prior written authorization from UFP.

PBS NEW HOMES
DUNCANS CREEK 154

SMITHFIELD FC
490 DUNCANS CREEK ROAD
ILLINGTON, NC, 27546

REVISIONS	DATE	DESCRIPTION	DSN

DESIGNER DV
LAYOUT DATE 09/20/2024
ARCH DATE -
STRUC DATE -
JOB #: 24091325F1

UFP SITE BUILT
A UFP INDUSTRIES COMPANY

Burlington, NC
Chesapeake, VA
Clinton, NC
Conway, SC
Jefferson, GA
Locust, NC
Liberty, NC
Ooltewah, TN
Pearisburg, VA
Stanfield, NC

Customer Service (800) 476-9356