

2018 APPENDIX B
BUILDING CODE SUMMARY
FOR ALL COMMERCIAL PROJECTS
(EXCEPT 1 AND 2 FAMILY DWELLINGS AND TOWNHOUSES)

NAME OF PROJECT: AMPLE STORAGE APARTMENT
ADDRESS: JACKSON BLVD-US HWY 421 ERWIN, NORTH CAROLINA ZIP CODE: 28339
OWNER/AUTHORIZED AGENT: BRADLEY GARNER PHONE #: (919) 625-8751 EMAIL: BRADLEY@CLAMPMANAGEMENT.COM
OWNED BY: CITY/COUNTY PRIVATE STATE
CODE ENFORCEMENT JURISDICTION: CITY ERWIN COUNTY STATE

DESIGNER	FIRM	NAME	LICENSE #	TELEPHONE NO.	E-MAIL
ARCHITECTURAL	CRUSE & ASSOCIATES, P.A.	RANDY CRUSE, PE	18909	(910) 892-4429	RCRUSE@CRUSEASSOCIATES.COM
BUILDING	CRUSE & ASSOCIATES, P.A.	RANDY CRUSE, PE	18909	(910) 892-4429	RCRUSE@CRUSEASSOCIATES.COM
CIVIL	CRUSE & ASSOCIATES, P.A.	RANDY CRUSE, PE	18909	(910) 892-4429	RCRUSE@CRUSEASSOCIATES.COM
ELECTRICAL	CRUSE & ASSOCIATES, P.A.	RANDY CRUSE, PE	18909	(910) 892-4429	RCRUSE@CRUSEASSOCIATES.COM
FIRE ALARM	CRUSE & ASSOCIATES, P.A.	RANDY CRUSE, PE	18909	(910) 892-4429	RCRUSE@CRUSEASSOCIATES.COM
PLUMBING	CRUSE & ASSOCIATES, P.A.	RANDY CRUSE, PE	18909	(910) 892-4429	RCRUSE@CRUSEASSOCIATES.COM
MECHANICAL	CRUSE & ASSOCIATES, P.A.	RANDY CRUSE, PE	18909	(910) 892-4429	RCRUSE@CRUSEASSOCIATES.COM
SPRINKLER-STANDPIPE	CRUSE & ASSOCIATES, P.A.	RANDY CRUSE, PE	18909	(910) 892-4429	RCRUSE@CRUSEASSOCIATES.COM
STRUCTURAL	CRUSE & ASSOCIATES, P.A.	RANDY CRUSE, PE	18909	(910) 892-4429	RCRUSE@CRUSEASSOCIATES.COM

2018 EDITION NC BUILDING CODE: NEW BUILDING ADDITION RENOVATION
 1ST TIME INTERIOR COMPLETIONS
 SHELL/CORE-CONTACT THE LEAD INSPECTION JURISDICTION FOR POSSIBLE ADDITIONAL PROCEDURES & REQUIREMENTS
 PHASED CONSTRUCTION-SHELL/CORE-CONTACT THE LEAD INSPECTION JURISDICTION FOR POSSIBLE ADDITIONAL PROCEDURES & REQUIREMENTS

2018 NC EXISTING BUILDING CODE: PRESCRIPTIVE REPAIR CHAPTER 14
ALTERATION: LEVEL I LEVEL II LEVEL III
 HISTORIC PROPERTY CHANGE OF USE

CONSTRUCTED: (DATE) _____ CURRENT OCCUPANCY(S): (CH. 3) _____
RENOVATED: (DATE) _____ PROPOSED OCCUPANCY(S) (CH. 3): _____
OCCUPANCY CATEGORY (TABLE 1604.5): CURRENT: I II III IV
PROPOSED: I II III IV

BASIC BUILDING DATA:
CONSTRUCTION TYPE: I-A II-A III-A IV V-A I-B II-B III-B V-B
SPRINKLERS: NO PARTIAL YES NFPA 13 NFPA 13R NFPA 13D
STANDPIPES: NO YES CLASS I II III WET DRY
PRIMARY FIRE DISTRICT: NO YES FLOOD HAZARD AREA: NO YES
SPECIAL INSPECTIONS REQUIRED: NO YES (CONTACT THE LOCAL INSPECTION JURISDICTION FOR ADDITIONAL PROCEDURES & REQUIREMENTS)

NOTE:
THIS CODE SUMMARY IS PROVIDED FOR A STAND ALONE (R-2) APARTMENT. IT IS SEPARATED FROM THE PRIMARY OCCUPANCY (S-1) BY A 4-HOUR FIRE WALL. SEE THE CODE SUMMARY FOR THE S-1 OCCUPANCY FOR THOSE DETAILS.

NEW (SQ. FT.)
S-1 2,400
R-2 1,200
TOTAL 3,600

GROSS BUILDING AREA: (RENOVATED AREA ONLY)		
FLOOR	EXISTING (SQ FT)	NEW (SQ FT)
3RD FLOOR		
2ND FLOOR		
MEZZANINE		
1ST FLOOR	1,200	1,200
BASEMENT		
TOTAL GROSS AREA:		1,200

ALLOWABLE AREA
PRIMARY OCCUPANCY CLASSIFICATION(S):
ASSEMBLY A-1 A-2 A-3 A-4 A-5
BUSINESS
EDUCATIONAL
FACTORY F-1 MODERATE F-2 LOW
HAZARDOUS H-1 DETONATE H-2 DEFLAGRATE H-3 COMBUST H-4 HEALTH H-5 HPM
INSTITUTIONAL I-1 CONDITION 1 2
 I-2 CONDITION 1 2
 I-3 CONDITION 1 2 3 4 5
 I-4
MERCANTILE
RESIDENTIAL R-1 R-2 R-3 R-4
STORAGE S-1 MODERATE S-2 LOW HIGH-PILED
 PARKING GARAGE OPEN ENCLOSED REPAIR GARAGE
 UTILITY AND MISCELLANEOUS

ACCESSORY OCCUPANCY CLASSIFICATION(S): _____
INCIDENTAL USES (TABLE 509): _____
SPECIAL USES (CHAPTER 4-LIST CODE SECTIONS): _____
SPECIAL PROVISIONS (CHAPTER 5-LIST CODE SECTIONS): _____
MIXED OCCUPANCY: NO YES SEPARATION: _____ HR. EXCEPTION: _____

NON-SEPARATED USE (508.3) THE REQUIRED TYPE OF CONSTRUCTION FOR THE BUILDING SHALL BE DETERMINED BY APPLYING THE HEIGHT AND AREA LIMITATIONS FOR EACH OF THE APPLICABLE OCCUPANCIES TO THE ENTIRE BUILDING. THE MOST RESTRICTIVE TYPE OF CONSTRUCTION, SO DETERMINED, SHALL APPLY TO THE ENTIRE BUILDING.
 SEPARATED USE (508.4) SEE BELOW FOR AREA CALCULATIONS FOR EACH STORY, THE AREA OF THE OCCUPANCY SHALL BE SUCH THAT THE SUM OF THE RATIOS OF THE ACTUAL FLOOR AREA OF EACH USE DIVIDED BY THE ALLOWABLE FLOOR AREA FOR EACH USE SHALL NOT EXCEED 1.

$$\frac{\text{ACTUAL AREA OF OCCUPANCY A}}{\text{ALLOWABLE AREA OF OCCUPANCY A}} + \frac{\text{ACTUAL AREA OF OCCUPANCY B}}{\text{ALLOWABLE AREA OF OCCUPANCY B}} \leq 1$$

STORY NO.	DESCRIPTION AND USE	(A) BLDG AREA PER STORY (ACTUAL)	(B) TABLE 506.2 AREA	(C) AREA FOR FRONTAGE INCREASE ^{1,5}	(D) ALLOWABLE AREA PER STORY OR UNLIMITED ^{2,3}
1	APARTMENT	1200	7000	-	7000

¹FRONTAGE AREA INCREASES FROM SECTION 506.2 ARE COMPUTED THUS:

- A. PERIMETER WHICH FRONTS A PUBLIC WAY OR OPEN SPACE HAVING 20 FEET MINIMUM WIDTH = _____(F)
B. TOTAL BUILDING PERIMETER = _____(P)
C. RATIO (F/P) = _____(F/P)
D. W = MINIMUM WIDTH OF PUBLIC WAY = _____(W)
E. PERCENT OF FRONTAGE INCREASE $I_f = 100[F/P - 0.25] \times W/30 = \text{_____}(\%)$

²UNLIMITED AREA APPLICABLE UNDER CONDITIONS OF SECTION 507.

³MAXIMUM BUILDING AREA = TOTAL NUMBER OF STORIES IN THE BUILDING x D (MAXIMUM 3 STORIES) (506.2).

⁴THE MAXIMUM AREA OF OPEN PARKING GARAGES MUST COMPLY WITH 406.5.4.

⁵FRONTAGE INCREASE IS BASED ON THE UNSPRINKLERED AREA VALUE IN TABLE 506.2.

ALLOWABLE HEIGHT

	ALLOWABLE	SHOWN ON PLANS	CODE REFERENCE ¹
BUILDING HEIGHT IN FEET (TABLE 504.3) ²	FEET <u>40</u>	13'-9"	
BUILDING HEIGHT IN STORIES (TABLE 504.4) ³	STORIES <u>1</u>	STORIES <u>1</u>	

1. PROVIDE CODE REFERENCE IF THE "SHOWN ON PLANS" QUANTITY IS NOT BASED ON TABLE 504.3 OR 504.4.
2. THE MAXIMUM HEIGHT OF AIR TRAFFIC CONTROL TOWERS MUST COMPLY WITH TABLE 412.3.1.
3. THE MAXIMUM HEIGHT OF OPEN PARKING GARAGES MUST COMPLY WITH TABLE 406.5.4.

FIRE PROTECTION REQUIREMENTS

BUILDING ELEMENT	FIRE SEPARATION REQUIRED (FEET)	RATING PROVIDED (W/ REDUCTION)	DETAIL AND SHEET #	DESIGN # FOR RATED ASSEMBLY	DESIGN # FOR RATED PENETRATION	DESIGN # FOR RATED JOINTS
STRUCTURAL FRAME, INCLUDING COLUMNS, GIRDERS, TRUSSES	-	0	-	-	-	-
BEARING WALLS	-	-	-	-	-	-
EXTERIOR	-	-	-	-	-	-
NORTH	0	-	-	-	-	-
EAST	0	-	-	-	-	-
WEST	0	-	-	-	-	-
SOUTH	0	-	-	-	-	-
INTERIOR	-	-	-	-	-	-
NONBEARING WALLS & PARTITIONS	-	-	-	-	-	-
EXTERIOR	-	-	-	-	-	-
NORTH	0	-	-	-	-	-
EAST	0	-	-	-	-	-
WEST	0	-	-	-	-	-
SOUTH	0	-	-	-	-	-
INTERIOR	-	-	-	-	-	-
FLOOR CONSTRUCTION INCLUDING SUPPORTING BEAMS AND JOISTS	-	0	-	-	-	-
FLOOR CEILING ASSEMBLY	-	-	-	-	-	-
COLUMNS SUPPORTING FLOORS	-	-	-	-	-	-
ROOF CONSTRUCTION INCLUDING SUPPORTING BEAMS AND JOISTS	-	0	-	-	-	-
ROOF CEILING ASSEMBLY	-	-	-	-	-	-
COLUMNS SUPPORTING ROOF	-	-	-	-	-	-
SHAFT ENCLOSURES-EXIT	-	-	-	-	-	-
SHAFT ENCLOSURES-OTHER	-	-	-	-	-	-
CORRIDOR SEPARATION	-	0	-	-	-	-
OCCUPANCY SEPARATION	-	-	-	-	-	-
PARTY/FIRE WALL SEPARATION	-	4 HR	-	-	-	-
SMOKE BARRIER SEPARATION	-	-	-	-	-	-
TENANT/DWELLING UNIT/SLEEPING UNIT SEPARATION	-	-	-	-	-	-
INCIDENTAL USE SEPARATION	-	-	-	-	-	-

*INDICATE SECTION NUMBER PERMITTING REDUCTION

PERCENTAGE OF WALL OPENING CALCULATIONS

FIRE SEPARATION DISTANCE (FEET) FROM PROPERTY LINES	DEGREE OF OPENINGS PROTECTION (TABLE 705.8)	ALLOWABLE AREA (%)	ACTUAL SHOWN ON PLANS (%)
>10'	UP/S	45%	18.5%

LIFE SAFETY SYSTEM REQUIREMENTS:

EMERGENCY LIGHTING: NO YES
EXIT SIGNS: NO YES
FIRE ALARM: NO YES
SMOKE DETECTION SYSTEMS: NO YES PARTIAL
CARBON MONOXIDE DETECTION: NO YES

LIFE SAFETY PLAN REQUIREMENTS:

LIFE SAFETY PLAN SHEET #, IF PROVIDED LS-1 OF 1

ACCESSIBLE DWELLING UNITS N/A (SECTION 1107)

TOTAL UNITS	ACCESSIBLE UNITS REQUIRED	ACCESSIBLE UNITS PROVIDED	TYPE A UNITS REQUIRED	TYPE A UNITS PROVIDED	TYPE B UNITS REQUIRED	TYPE B UNITS PROVIDED	TOTAL ACCESSIBLE UNITS PROVIDED

ACCESSIBLE PARKING-SEE SITE PLAN (SECTION 1106)

LOT OR PARKING AREA	TOTAL # OF PARKING SPACES		# OF ACCESSIBLE SPACES PROVIDED			TOTAL # ACCESSIBLE PROVIDED
	REQUIRED	PROVIDED	REGULAR WITH 5' ACCESS AISLE	VAN SPACES WITH 132" ACCESS AISLE	8' ACCESS AISLE	

PLUMBING FIXTURE REQUIREMENTS (TABLE 2902.1)

SPACE USE	WATERCLOSETS	LAVATORIES		SHOWERS/TUBS	DRINKING FOUNTAINS		KITCHEN SINK	CLOTHES WASHER
		MALE	FEMALE		REGULAR	ACCESS.		
APARTMENT	REQUIRED	(1) UNISEX	(1) UNISEX	1	N/A	N/A	1	1
	PROVIDED	(1) UNISEX	(1) UNISEX	1	-	-	1	1

SPECIAL APPROVALS

SPECIAL APPROVAL: (LOCAL JURISDICTION, DEPARTMENT OF INSURANCE, OSC, DPI, DHHS, ICC, ETC., DESCRIBE BELOW)

DESIGN LOADS: STRUCTURAL DESIGN

SNOW (I_s) 1.0
SEISMIC (I_e) 1.0
LIVE LOADS: ROOF 20.0 PSF
MEZZANINE N/A PSF
FLOOR 100 PSF
GROUND SNOW LOAD: 10 PSF
WIND LOAD: BASIC WIND SPEED 119 MPH (ASCE-7)
EXPOSURE CATEGORY C

SEISMIC DESIGN CATEGORY A B C D

PROVIDE THE FOLLOWING SEISMIC DESIGN PARAMETERS:
OCCUPANCY CATEGORY (TABLE 1604.5) I II III IV
SPECTRAL RESPONSE ACCELERATION S_s 13.5 %g S₁ 6.6 %g
SITE CLASSIFICATION (ASCE 7): A B C D E F
DATA SOURCE: FIELD TEST PRESUMPTIVE HISTORICAL DATA
BASIC STRUCTURAL SYSTEM (CHECK ONE)
 BEARING WALL DUAL W/SPECIAL MOMENT FRAME
 BUILDING FRAME DUAL W/INTERMEDIATE R/C OR SPECIAL STEEL
 MOMENT FRAME INVERTED PENDULUM

ANALYSIS PROCEDURE SIMPLIFIED EQUIVALENT LATERAL FORCE DYNAMIC
ARCHITECTURAL, MECHANICAL, COMPONENTS ANCHORED? YES NO

LATERAL DESIGN CONTROL: EARTHQUAKE WIND
SOIL BEARING CAPACITIES:
FIELD TEST (PROVIDE COPY OF TEST REPORT) _____ PSF
PRESUMPTIVE BEARING CAPACITY 2,000 PSF
PILE SIZE, TYPE, AND CAPACITY _____

ENERGY REQUIREMENTS: (ADDITION ONLY)

THE FOLLOWING DATA SHALL BE CONSIDERED MINIMUM AND ANY SPECIAL ATTRIBUTE REQUIRED TO MEET THE ENERGY CODE SHALL ALSO BE PROVIDED. EACH DESIGNER SHALL FURNISH THE REQUIRED PORTIONS OF THE PROJECT INFORMATION FOR THE PLAN DATA SHEET. IF PERFORMANCE METHOD, STATE THE ANNUAL ENERGY COST FOR THE STANDARD REFERENCE DESIGN VS THE ANNUAL ENERGY COST FOR THE PROPOSED DESIGN.

EXISTING BUILDING ENVELOPE COMPLIES WITH CODE: NO YES (THE REMAINDER OF THIS SECTION IS NOT APPLICABLE)

EXEMPT BUILDING NO YES PROVIDE CODE OR STATUTORY REFERENCE: _____
CLIMATE ZONE: 3A 4A 5A

METHOD OF COMPLIANCE: ENERGY CODE PERFORMANCE PRESCRIPTIVE
ASHRAE 90.1 PERFORMANCE PRESCRIPTIVE

OTHER: PERFORMANCE (SPECIFY SOURCE) _____

THERMAL ENVELOPE (PRESCRIPTIVE METHOD ONLY)

ROOF/CEILING ASSEMBLY (EACH ASSEMBLY):
DESCRIPTION OF ASSEMBLY: PRE-FABRICATED WOOD TRUSS/ASPHALT SHINGLE
U-VALUE OF TOTAL ASSEMBLY: 0.024
R-VALUE OF INSULATION: R-42
SKYLIGHTS IN EACH ASSEMBLY: ROOF
U-VALUE OF SKYLIGHT: 0.60
TOTAL SQUARE FOOTAGE OF SKYLIGHTS IN EACH ASSEMBLY: N/A

EXTERIOR WALLS (EACH ASSEMBLY):
DESCRIPTION OF ASSEMBLY: WOOD STUD, BATT INSULATION, BRICK VENEER OR HARDI-PLANK SIDING
U-VALUE OF TOTAL ASSEMBLY: 0.05
R-VALUE OF INSULATION: R-20
OPENINGS (WINDOWS OR DOORS WITH GLAZING): DOUBLE PANE, METAL FRAME
U-VALUE OF ASSEMBLY: 0.9 SOLAR HEAT GAIN COEFFICIENT: N/A
PROJECTION FACTOR: N/A DOOR R-VALUES: R-1.7 MIN.

WALLS BELOW GRADE (EACH ASSEMBLY):
DESCRIPTION OF ASSEMBLY: N/A
U-VALUE OF TOTAL ASSEMBLY: N/A R-VALUE OF INSULATION: N/A

FLOORS OVER UNCONDITIONED SPACE (EACH ASSEMBLY):
DESCRIPTION OF ASSEMBLY: N/A
U-VALUE OF TOTAL ASSEMBLY: N/A R-VALUE OF INSULATION: N/A

FLOOR SLAB ON GRADE:
DESCRIPTION OF ASSEMBLY: SLAB-ON-GRADE
R-VALUE OF INSULATION: R-10
U-VALUE OF TOTAL ASSEMBLY: 0.10
HORIZONTAL / VERTICAL REQUIREMENT: N/A
SLAB HEATED? NO

SUMMARY:

ENERGY CODE: 2018 NORTH CAROLINA STATE BUILDING CODE: ENERGY CONSERVATION CODE
BUILDING CODE: 2018 NORTH CAROLINA STATE BUILDING CODE: BUILDING CODE
MECHANICAL CODE: 2018 NORTH CAROLINA STATE BUILDING CODE: MECHANICAL CODE
PLUMBING CODE: 2018 NORTH CAROLINA STATE BUILDING CODE: PLUMBING CODE
ELECTRICAL CODE: 2020 NATIONAL ELECTRIC CODE
ACCESSIBILITY CODE: ICC/ANSI 117.1-2009 AMERICAN NATIONAL STANDARD ACCESSIBLE AND USABLE BUILDINGS AND FACILITIES
CONSTRUCTION: V-B
OCCUPANCY: R-2

ELECTRICAL SUMMARY - SEE SHEET E-2 OF 2

MECHANICAL SUMMARY - SEE SHEET M-1 OF 1

PLUMBING SUMMARY - SEE SHEET P-1 OF 1

SHEET INDEX

BD-1 OF 1 APPENDIX B
LS-1 OF 1 LIFE SAFETY PLAN
F-1 OF 3 PROPOSED FLOOR & FOUNDATION PLAN
F-2 OF 3 ROOF FRAMING TRUSS DRAWINGS & WALL SECTION
F-3 OF 3 ELEVATIONS
P-1 OF 1 SUPPLY & WASTE PIPING PLAN
M-1 OF 1 MECHANICAL HVAC PLAN
E-1 OF 2 ELECTRICAL LIGHTING & POWER PLAN
E-2 OF 2 ELECTRICAL NOTES RISER DIAGRAM & PANEL SCHEDULE

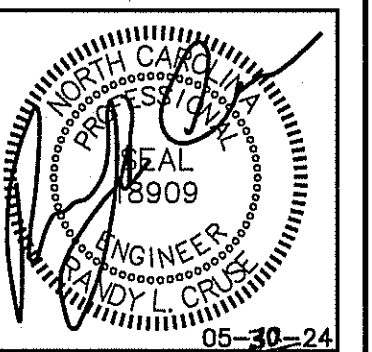

PLANS FOR:
AMPLE STORAGE APARTMENT
JACKSON BOULEVARD-U.S. HIGHWAY 421
ERWIN, NORTH CAROLINA 28339

REVISIONS

NO.	DESCRIPTION

414 E. Robertson St.
Erwin, NC 28339
Phone: (910) 892-4429
Fax: (910) 892-0102

Cruse
And
Associates, P.A.

THESE DOCUMENTS ARE INSTRUMENTS OF SERVICE AND AS SUCH THESE DRAWINGS, DESIGNS, AND DESIGN CONCEPTS PRESENTED REMAIN THE PROPERTY OF THE ENGINEER. PUBLISH OR DUPLICATE THE DRAWINGS OR DESIGNS ONLY WITH THE WRITTEN PERMISSION OF THE ENGINEER.
© COPY RIGHT

DATE 05-30-24
DRAWN BY BAM
JOB NO. 24-28

SHEET NO.
BD-1 OF 1

LIFE SAFETY PLAN REQUIREMENTS:

- ☒ FIRE AND/OR SMOKE RATED WALL LOCATIONS (CHAPTER 7) - SEE NOTE 1
- ☒ ASSUMED AND REAL PROPERTY LINE LOCATIONS - SEE NOTE 2
- ☒ EXTERIOR WALL OPENING AREA WITH RESPECT TO DISTANCE TO ASSUMED PROPERTY LINES (705.8) - SEE NOTE 3
- ☒ OCCUPANCY TYPES FOR EACH AREA AS IT RELATES TO OCCUPANT LOAD CALCULATION (TABLE 1004.1.2)
- ☒ OCCUPANT LOADS FOR EACH AREA
- ☒ EXIT ACCESS TRAVEL DISTANCES (1017)
- ☒ COMMON PATH OF TRAVEL DISTANCES (1008.2.1 & 1006.3.2(1))
- ☒ DEAD END LENGTHS (1020.4) - SEE NOTE 4
- ☒ CLEAR EXIT WIDTHS FOR EACH EXIT DOOR
- ☒ MAXIMUM CALCULATED OCCUPANT LOAD CAPACITY EACH EXIT DOOR CAN ACCOMMODATE BASED ON EGRESS WIDTH (1005.3)
- ☒ ACTUAL OCCUPANT LOAD FOR EACH EXIT DOOR
- ☒ A SEPARATE SCHEMATIC PLAN INDICATING WHERE FIRE RATED FLOOR/CEILING AND/OR ROOF STRUCTURE IS PROVIDED FOR PURPOSES OF OCCUPANCY SEPARATION. SEE NOTE 5
- ☒ LOCATION OF DOORS WITH PANIC HARDWARE (1008.1.10) - SEE NOTE 6
- ☒ LOCATION OF DOORS WITH DELAYED EGRESS LOCKS AND THE AMOUNT OF DELAY (1008.1.9.7) - SEE NOTE 7
- ☒ LOCATION OF DOORS WITH ELECTROMAGNETIC EGRESS LOCKS (1008.1.9.8) - SEE NOTE 7
- ☒ LOCATION OF DOORS EQUIPPED WITH HOLD-OPEN DEVICES - SEE NOTE 7
- ☒ LOCATION OF EMERGENCY ESCAPE WINDOWS (1029) - SEE NOTE 7
- ☒ THE SQUARE FOOTAGE OF EACH FIRE AREA (802) - SEE NOTE 8
- ☒ THE SQUARE FOOTAGE OF EACH SMOKE COMPARTMENT (407.5) - SEE NOTE 9
- ☐ NOTE ANY CODE EXCEPTIONS OR TABLE NOTES THAT MAY HAVE BEEN UTILIZED REGARDING THE ITEMS ABOVE

LIFE SAFETY PLAN NOTES:

1. SEE LEGEND FOR RATED WALLS.
2. ALL ASSUMED AND REAL PROPERTY LINES $\geq 10'$
3. ALLOWED; APARTMENT UP/S = 45%
ACTUAL; 11.0% < ALLOWED 45%
4. NO DEAD ENDS; 20' ALLOWED
5. NO RATING REQUIRED FOR THIS STRUCTURE.
6. PANIC HARDWARE NOT REQUIRED.
7. NO DELAYED EGRESS LOCKS, ELECTROMAGNETIC LOCKS, HOLD OPEN DEVICES, OR EMERGENCY ESCAPE WINDOWS
8. BUILDING LESS THAN 12,000 SQ. FT. AREAS DO NOT EXCEED CODE ALLOWANCE.
9. BUILDING MEETS CODE REQUIREMENTS WITHOUT SUBDIVISION INTO SMOKE COMPARTMENTS; NO SMOKE COMPARTMENTS

EXIT WIDTH

USE GROUP OR SPACE DESCRIPTION	(a)		(b)		(c)		EXIT WIDTH (in)				
	AREA ¹ SQ. FT.	AREA ¹ PER OCCUPANT (TABLE 1004.1.2)	CALCULATED OCCUPANT LOAD (a/b)	EGRESS WIDTH PER OCCUPANT (TABLE 1005.1)	STAIR	LEVEL	REQUIRED WIDTH (SECTION 1005.1) (a/b) x c	ACTUAL WIDTH SHOWN ON PLANS			
APARTMENT	1200	200 GROSS	6	N/A	.2	N/A	1.2"	N/A	47"		
TOTAL											

1. SEE TABLE 1004.1.2 TO DETERMINE WHETHER NET OR GROSS AREA IS APPLICABLE. SEE DEFINITION "AREA, GROSS" AND "AREA, NET" (SECTION 1002, DEFINED IN CHAPTER 2)
2. MINIMUM STAIRWAY WIDTH (SECTION 1011.2); MIN. CORRIDOR WIDTH (SECTION 1020.2); MIN. DOOR WIDTH (SECTION 1010.1.1)
3. MINIMUM WIDTH OF EXIT PASSAGEWAY (SECTION 1024)
4. SEE SECTION 1005.6 FOR CONVERGING EXITS.
5. THE LOSS OF ONE MEANS OF EGRESS SHALL NOT REDUCE THE AVAILABLE CAPACITY TO LESS THAN 50% OF THE TOTAL REQUIRED (SECTION 1005.5)
6. ASSEMBLY OCCUPANCIES (SECTION 1029)

**EXIT REQUIREMENTS:
NUMBER AND ARRANGEMENTS OF EXITS**

FLOOR, ROOM OR SPACE DESIGNATION	MINIMUM NO. OF EXITS		TRAVEL DISTANCE		ARRANGEMENT MEANS OF EGRESS 1,2 (SECTION 1016-1021)	
	REQ'D.	SHOWN ON PLANS	ALLOWABLE TRAVEL DISTANCE (TABLE 1017.2)	ACTUAL TRAVEL DISTANCE SHOWN ON PLANS	REQUIRED DISTANCE BETWEEN EXIT DOORS	ACTUAL DISTANCE SHOWN ON PLANS
APARTMENT	1	1	75'	56'-11"	N/A	-

1. CORRIDOR DEAD ENDS (SECTION 1020.4)
2. BUILDINGS W/SINGLE EXITS (TABLE 1006.3.2(2)), SPACES W/ONE EXIT OR EXIT ACCESS DOORWAY (TABLE 1006.2.1)
3. COMMON PATH OF TRAVEL (SECTION 1029.8)

MAXIMUM CALCULATED OCCUPANT LOAD CAPACITY EACH EXIT DOOR CAN ACCOMMODATE BASED ON EGRESS WIDTH (1005.1)

▲ 35" CLEAR WIDTH DIVIDED BY .2" = 175 OCCUPANTS
CALCULATED OCCUPANCY PER EXIT = 6 PEOPLE
CALCULATED OCCUPANCY DOES NOT EXCEED MAXIMUM CAPACITY OF EXIT.

NOTE:
AREA/ROOM/SPACE DESIGNATIONS USED ON LIFE SAFETY PLANS ARE EXCLUSIVE TO LIFE SAFETY PLAN ONLY, AND ARE NOT INDICATIVE OF ANY ACTUAL SPACE DESIGNATIONS USED ELSEWHERE.

LEGEND

☒ F.E. FIRE EXTINGUISHER AND CABINET CLASS ABC 10 POUNDS

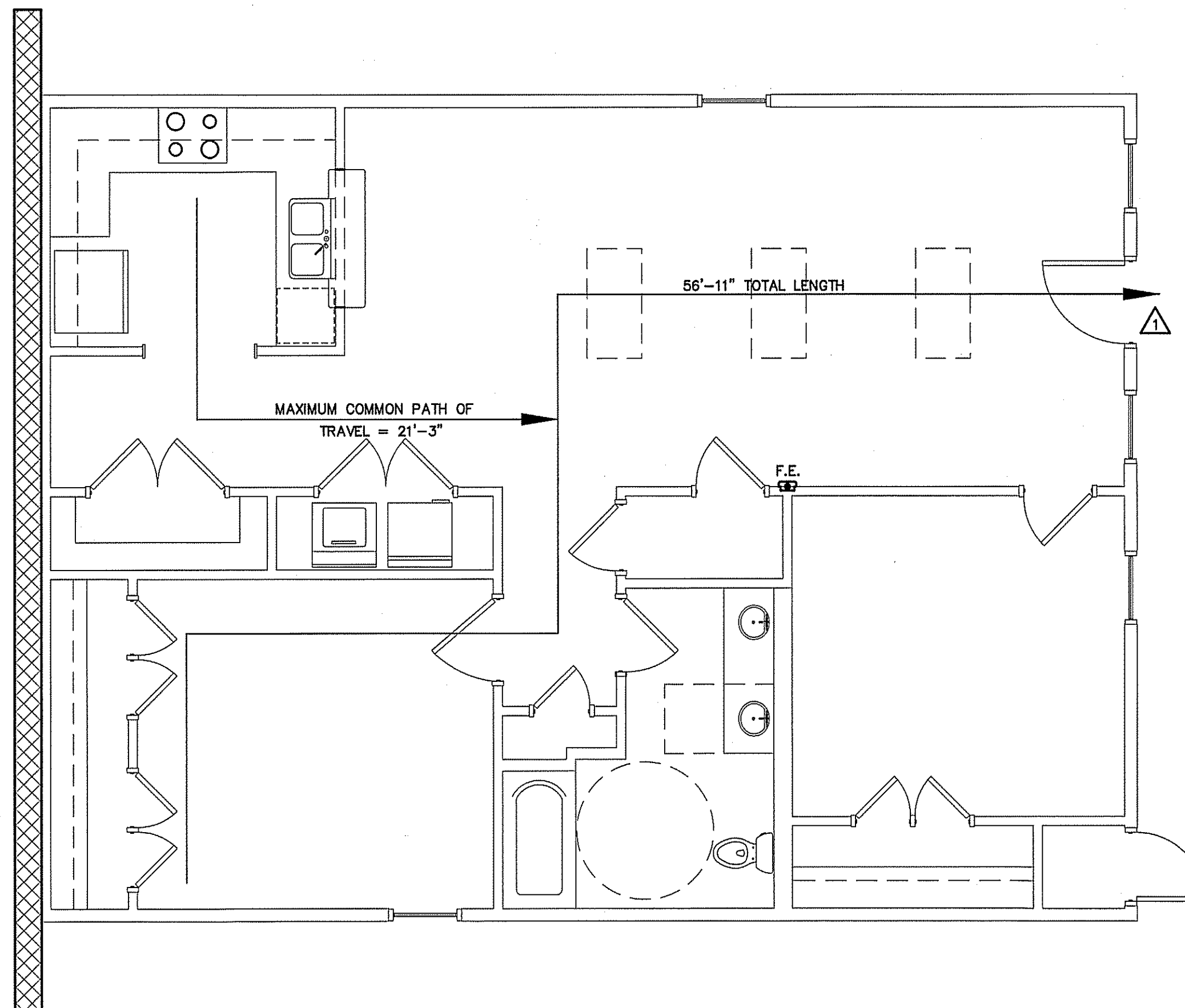

LIFE SAFETY PLAN-APARTMENT
SCALE: 1/4" = 1'-0"

LEGEND

☒ 4 HOUR RATED FIRE BARRIER WALL U907

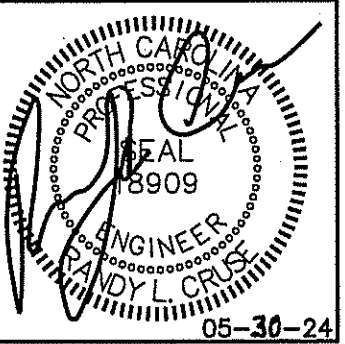

PLANS FOR:
AMPLE STORAGE APARTMENT
JACKSON BOULEVARD-U.S. HIGHWAY 421
ERWIN, NORTH CAROLINA 28339

REVISIONS

NO.	

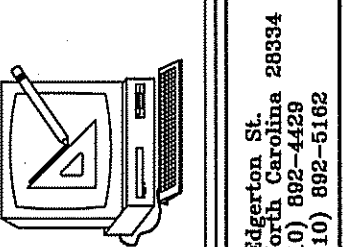

**Cruse
And
Associates, P.A.**

414 E. Edgerton St.
Raleigh, NC 27601
Phone: (919) 885-0100
Fax: (919) 885-0105

THESE DOCUMENTS ARE INSTRUMENTS OF SERVICE AND AS SUCH THESE DRAWINGS, DESIGNS, AND DESIGN CONCEPTS PRESENTED REMAIN THE PROPERTY OF THE ENGINEER. PUBLISH OR DUPLICATE THE DRAWINGS OR DESIGNS ONLY WITH THE WRITTEN PERMISSION OF THE ENGINEER.
© COPY RIGHT

DATE 05-30-24
DRAWN BY BAM
JOB NO. 24-28

SHEET NO.
LS-1 OF 1

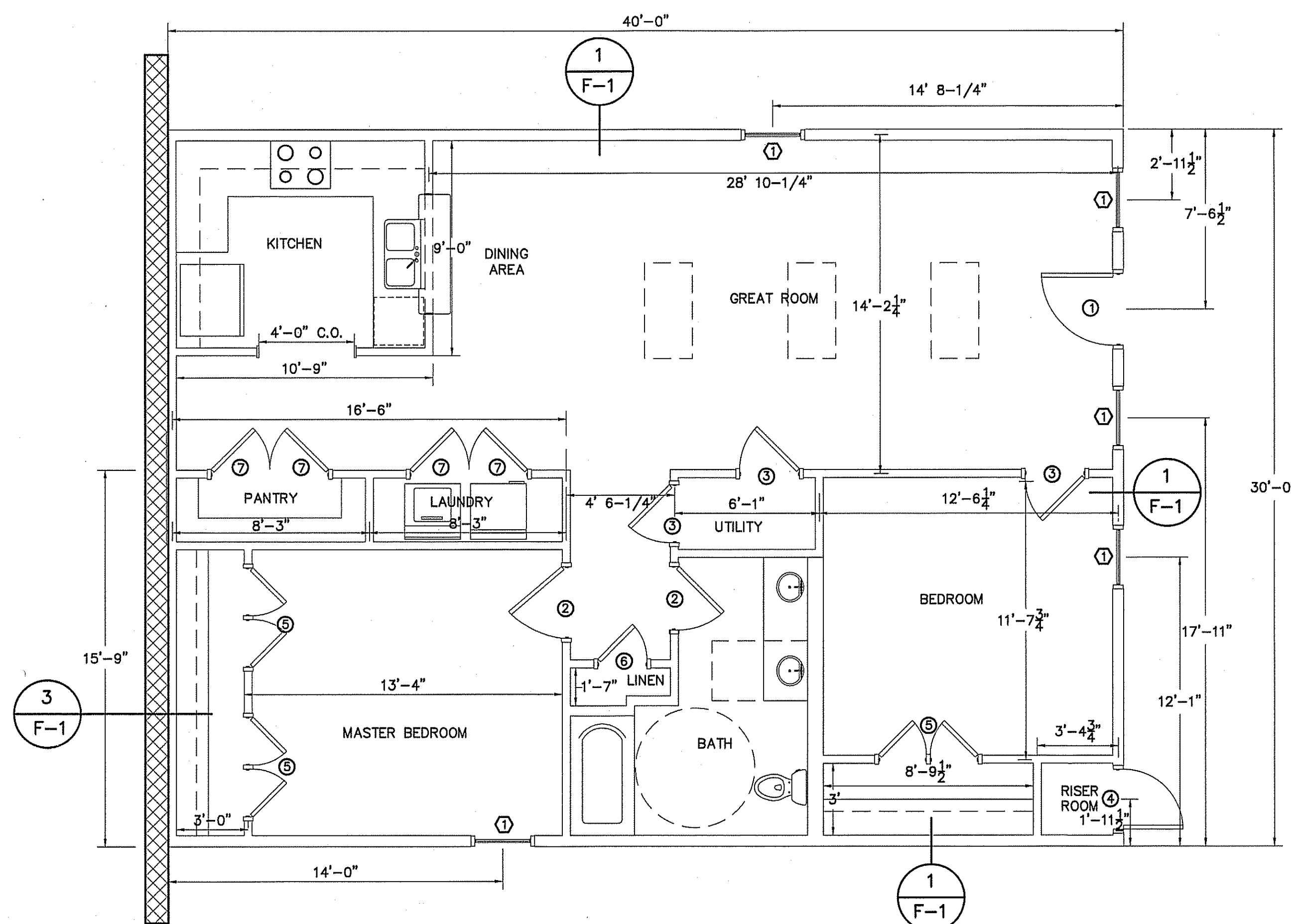

FLOOR PLAN
SCALE: 1/4" = 1'-0"

DOOR SCHEDULE				
MARK	DOOR SIZE			REMARKS
	WIDE	HIGH	THICK.	
①	3'-0"	6'-8"	1 5/8"	EXTERIOR DOOR
②	3'-0"	6'-8"	1 5/8"	INTERIOR WOOD DOOR
③	2'-6"	6'-8"	1 5/8"	INTERIOR WOOD DOOR
④	2'-6"	6'-8"	1 5/8"	EXTERIOR DOOR
⑤	(2) 2'-0"	6'-8"	1 5/8"	DOUBLE INTERIOR WOOD DOORS
⑥	2'-0"	6'-8"	1 5/8"	INTERIOR WOOD DOOR
⑦	2'-6"	6'-8"	1 5/8"	INTERIOR WOOD DOOR

WINDOW SCHEDULE				
MARK	WINDOW SIZE		REMARKS	
	WIDE	HIGH		
①	2'-8"	4'-10"	MINIMUM 22" A.F.F.	

VERIFY DOOR AND WINDOW SELECTION WITH OWNER BEFORE BEGINNING CONSTRUCTION.

LEGEND
 4 HOUR RATED FIRE BARRIER WALL U907

- FOUNDATION & CONCRETE NOTES:**
- FOUNDATION DESIGN BASED ON 2000 LBS/SF ALLOWABLE SOIL BEARING CAPACITY. CONTACT ENGINEER IF POOR SOIL CONDITIONS ARE ENCOUNTERED IN THE FOUNDATION EXCAVATION.
 - ALL CONCRETE SHALL BE 3000 PSI AT 28 DAYS.
 - REINFORCING STEEL SHALL BE GRADE 60.
 - WIRE REINFORCEMENT SHALL BE 6X6, 10/10.
 - VAPOR BARRIER: ALL SLABS ON GRADE SHALL BE REPLACED ON 6 MIL POLY VAPOR BARRIER.
 - SAW CUT CONTROL JOINTS AS INDICATED ON PLAN.
 - CURING COMPOUND SHALL BE APPLIED UNLESS OTHERWISE NOTED.
 - SURFACE SHALL BE BROOM FINISHED UNLESS OTHERWISE NOTED.
 - INSTALL ISOLATION JOINTS AS INDICATED ON PLANS.
 - SLOPE CONCRETE SURFACE TO DRAIN.

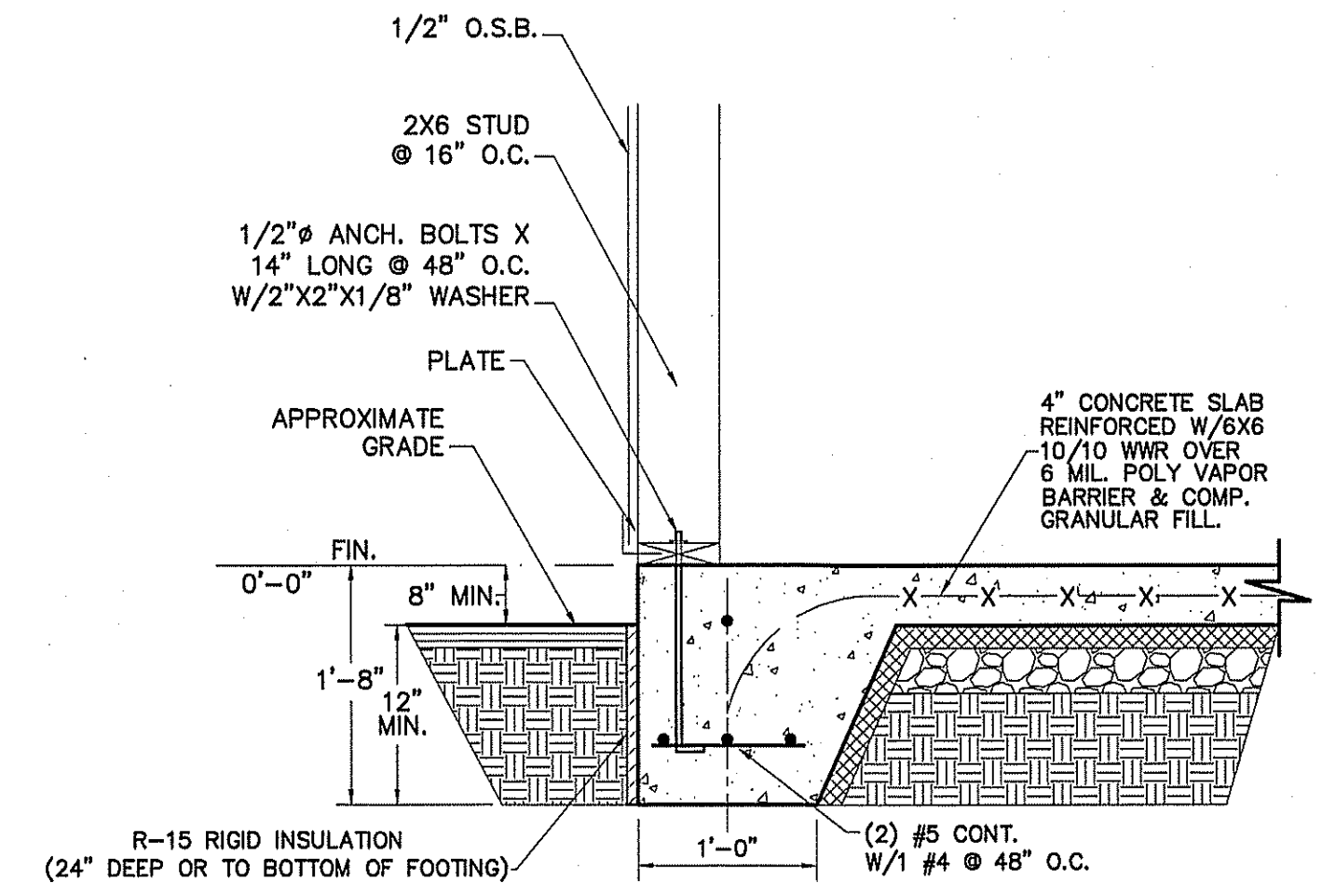

SECTION
SCALE: 1" = 1'-0"

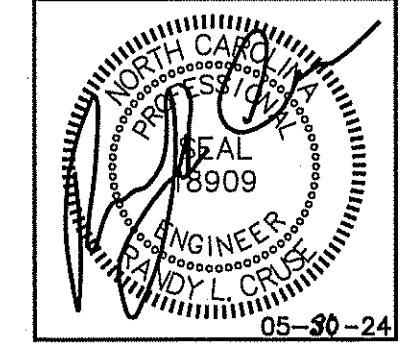

PLANS FOR:
AMPLE STORAGE APARTMENT
 JACKSON BOULEVARD-U.S. HIGHWAY 421
 ERWIN, NORTH CAROLINA 28339

REVISIONS	
NO.	

Cruse And Associates, P.A.
 414 E. Robertson St.
 Raleigh, NC 27604
 P.O. Box 1100
 Raleigh, NC 27602
 TEL: (919) 882-4429
 FAX: (919) 882-5102

THESE DOCUMENTS ARE INSTRUMENTS OF SERVICE AND AS SUCH THESE DRAWINGS, DESIGNS, AND DESIGN CONCEPTS PRESENTED REMAIN THE PROPERTY OF THE ENGINEER. PUBLISH OR DUPLICATE THE DRAWINGS OR DESIGNS ONLY WITH THE WRITTEN PERMISSION OF THE ENGINEER.
 © COPY RIGHT

DATE 05-30-24
 DRAWN BY BAM
 JOB NO. 24-28

SHEET NO.
F-1 OF 3

- STRUCTURAL MASONRY NOTES:**
- STRUCTURAL MASONRY INCLUDES ALL LOAD BEARING MASONRY PIERS, LOAD BEARING WALLS, FOUNDATION WALLS, WALLS DESIGNATED ON DRAWING AS SHEAR WALLS AND OTHER MASONRY SO DESIGNATED ON DRAWINGS.
 - MORTAR SHALL BE TYPE S ASTM C270.
 - COMPRESSIVE STRENGTH OF MASONRY UNITS*
 CONCRETE UNITS 2000 PSI NET AREA
 SOLID CLAY UNITS 8000 PSI
 - GROUT FOR REINFORCED MASONRY:
 FOR GROUT SPACE 3" BY 4" OR LARGER USE 9" TO 11" SLUMP 3/8" MAXIMUM SIZE FOR PEA GRAVEL CONCRETE.
 FOR GROUT SPACE 2" BY 4" TO 3" BY 4" USE 5" SLUMP FINE GROUT ASTM C476. MINIMUM COMPRESSIVE STRENGTH 3000 PSI.
 - MAXIMUM MASONRY FILL HEIGHT FOR PEA GRAVEL IS 8 FEET.
 MAXIMUM MASONRY FILL HEIGHT FOR GROUT IS 2 FEET.
 - PROVIDE CLEANOUT OPENING AT THE BOTTOM OF EACH GROUT LIFT. CLEANOUT OPENING SHALL BE PROVIDED AT EACH CELL TO BE FILLED WITH GROUT.
 - REINFORCING STEEL SHALL BE GRADE 60. TIES SHALL BE GRADE 40. TIE REINFORCING IN POSITION AND POUR GROUT AROUND THE STEEL. STEEL SHALL NOT BE PUSHED INTO POURED GROUT.
 - TIE ALL WYTHES WITH HORIZONTAL REINF. AS SPECIFIED.

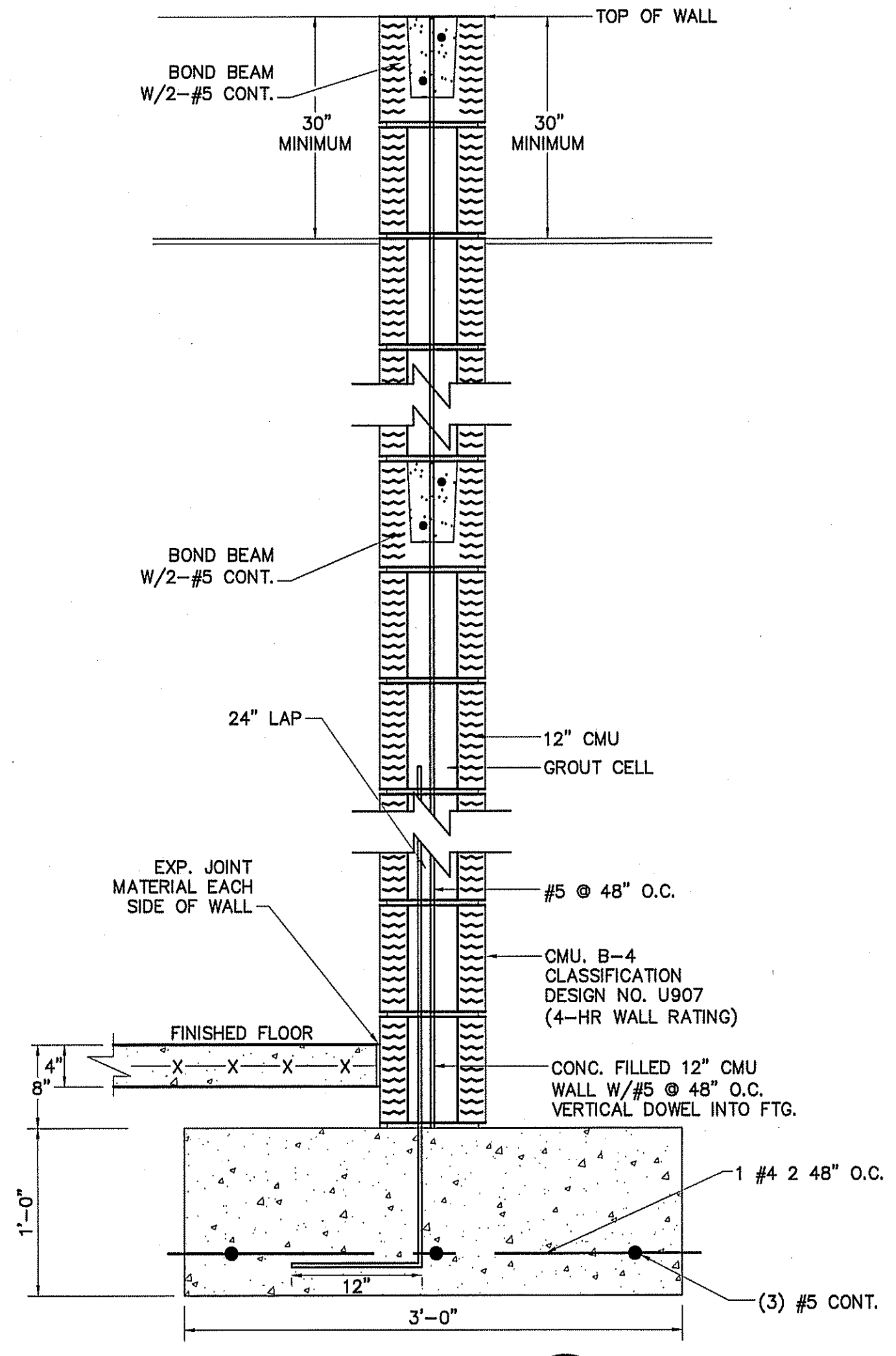

SECTION
SCALE: 1" = 1'-0"

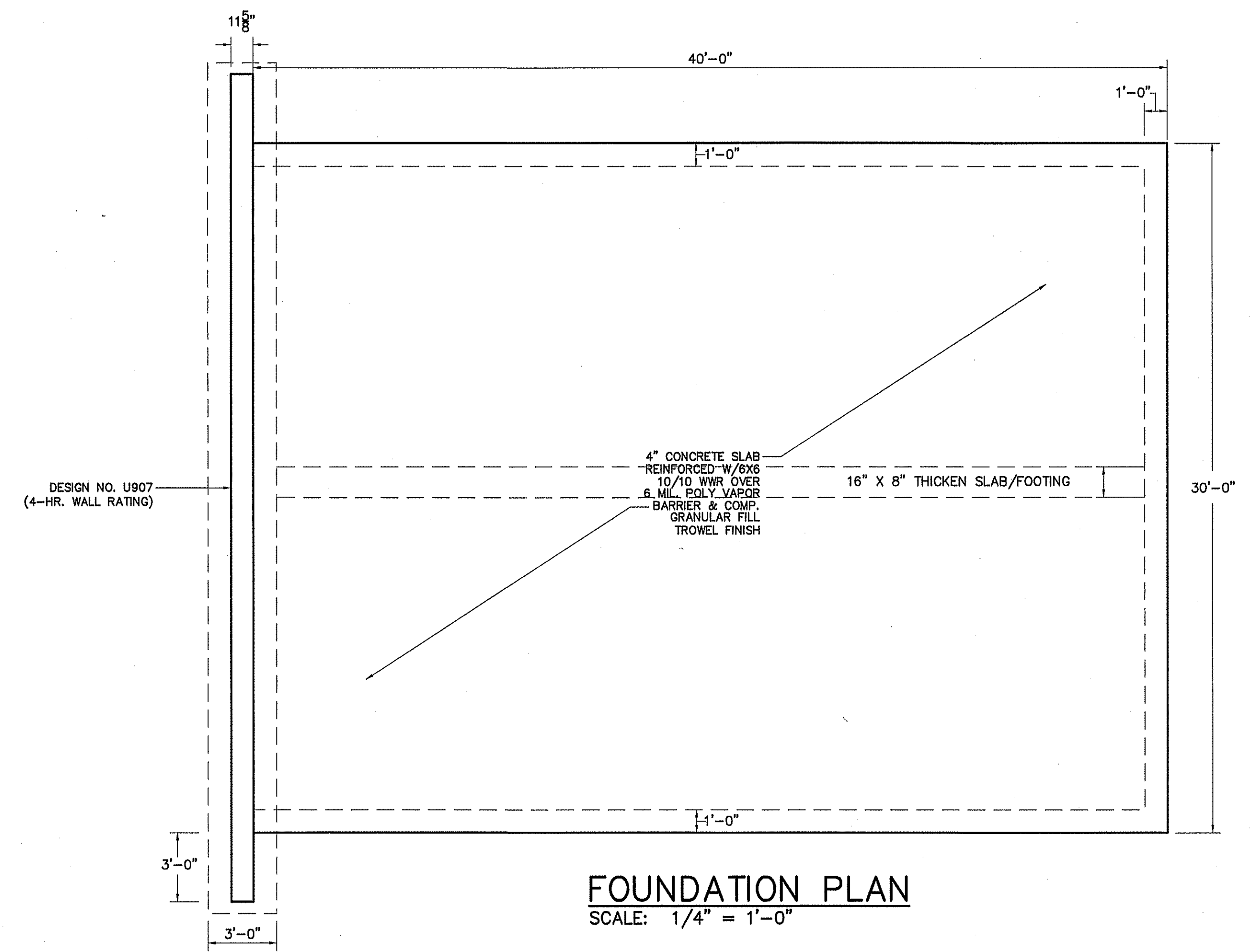

FOUNDATION PLAN
SCALE: 1/4" = 1'-0"

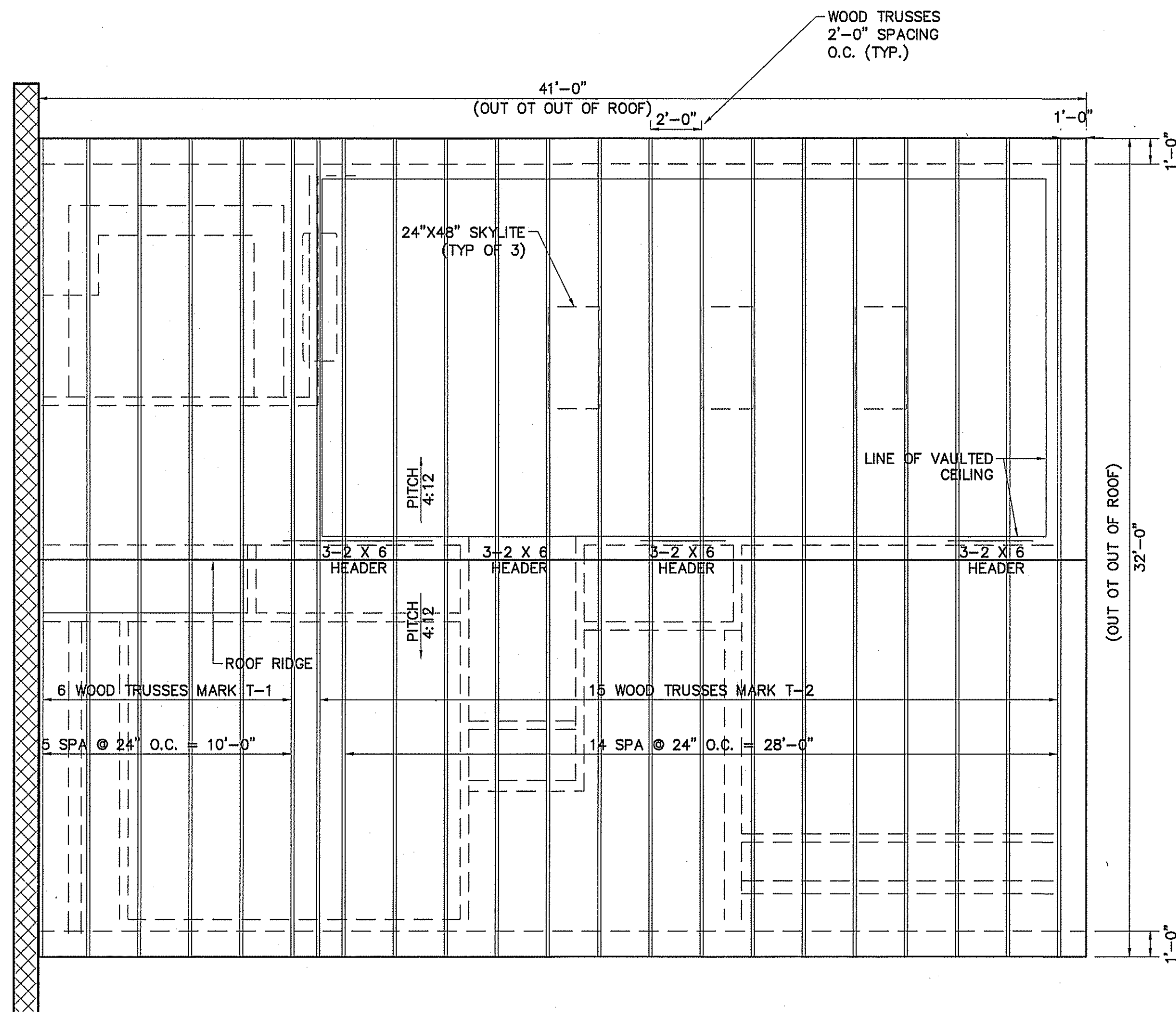

ROOF FRAMING PLAN
SCALE: 1/4" = 1'-0"

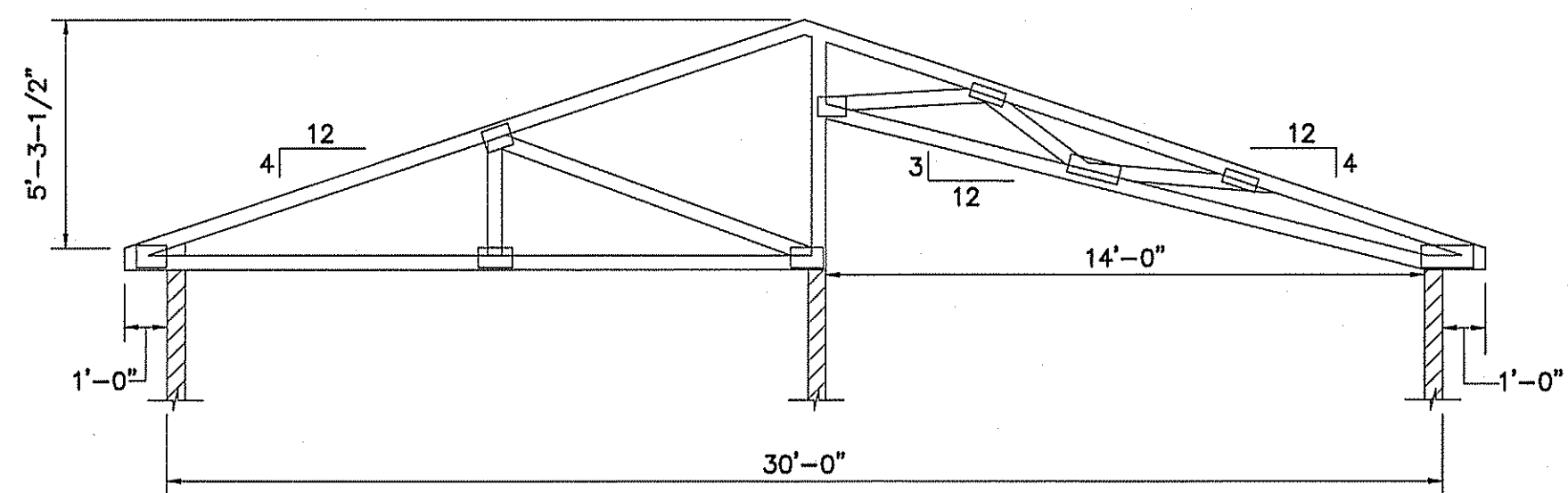

3 ELEVATION TRUSS "T-2"
F-2 SCALE: 1/4" = 1'-0"

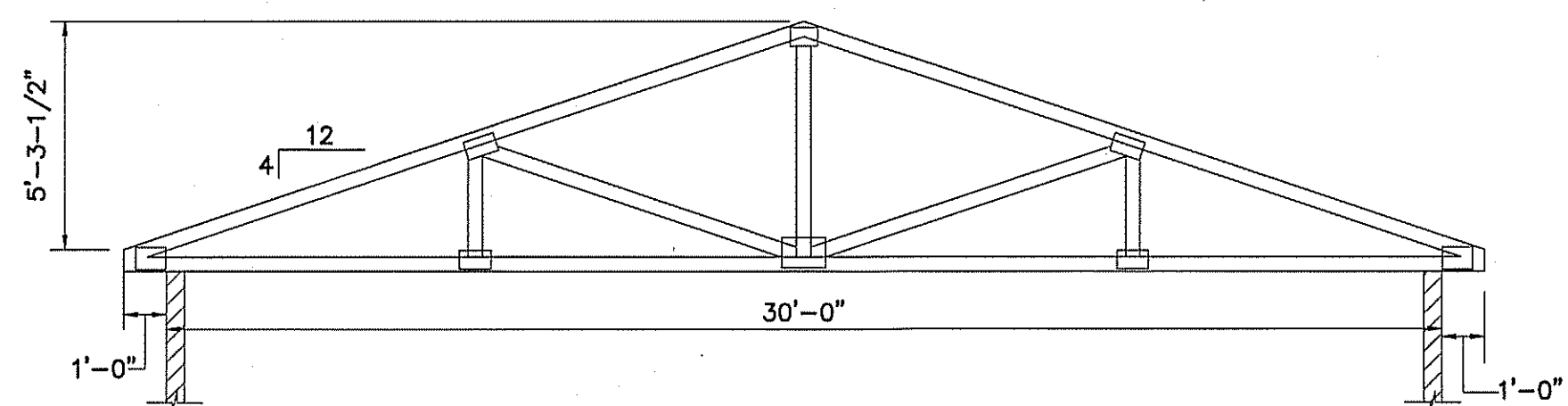

2 ELEVATION TRUSS "T-1"
F-2 SCALE: 1/4" = 1'-0"

ROUGH CARPENTRY NOTES:

- ROUGH CARPENTRY SHALL BE INSTALLED IN ACCORDANCE WITH THE NATIONAL FOREST PRODUCTS ASSOCIATION (NFPA) "NATIONAL DESIGN SPECIFICATIONS FOR WOOD CONSTRUCTION."
- WOOD FRAMING MEMBERS PERMANENTLY EXPOSED TO THE WEATHER AND ALL SILL PLATES AROUND THE BUILDING PERIMETER SHALL BE PRESERVATIVE-TREATED IN ACCORDANCE WITH THE SPECIFICATION.
- UNLESS OTHERWISE NOTED, ALL NAILING FASTENERS SHALL CONFORM TO "FASTENING SCHEDULE" OF THE NORTH CAROLINA STATE BUILDING CODE, LATEST EDITION.
- CONSTRUCTION PANELS SHALL COMPLY WITH PS 1 "U.S. PRODUCT STANDARD FOR CONSTRUCTION AND INDUSTRIAL PLYWOOD" FOR PLYWOOD CONSTRUCTION PANELS AND THE FOLLOWING REQUIREMENTS:
A) EXTERIOR WALL AND SHEARWALL WALL SHEATHING: 1/2" APA RATED SHEATHING, EXTERIOR EXPOSURE I EXPOSURE DURABILITY CLASSIFICATION.
B) ROOF SHEATHING: 1/2" APA RATED SHEATHING, EXTERIOR EXPOSURE DURABILITY CLASSIFICATION.
- WOOD FRAMING SHALL COMPLY WITH THE FOLLOWING REQUIREMENTS:
A) MOISTURE CONTENT - SEASONED, WITH 19 PERCENT MAXIMUM MOISTURE CONTENT.
B) GRADE - NO. 2 SPF
- PROVIDE DOUBLE JOISTS UNDER ALL PARTITIONS WHICH RUN PARALLEL WITH JOISTS. PROVIDE MULTIPLE STUDS AS INDICATED ON THE PLANS.
- PROVIDE HEADERS OF THE SAME CROSS SECTION AS JOISTS OR RAFTERS TO FRAME AROUND ALL OPENINGS TO SUPPORT SHEATHING.
- ATTACH BLOCKING AND NAILERS TO FRAMING USING 3/8" DIAMETER POWDER ACTUATED FASTENERS AT 24" ON CENTER OR 1/2" DIAMETER BOLTS AT 48" ON CENTER STAGGER FASTENERS TO ALTERNATE SIDES OF BEAM WEB.

PREFABRICATED WOOD TRUSS NOTES:

- PREFABRICATED METAL-PLATE-CONNECTED WOOD TRUSSES SHALL BE DESIGNED IN ACCORDANCE WITH THE NATIONAL FOREST PRODUCTS ASSOCIATION (NFPA) "NATIONAL DESIGN SPECIFICATION FOR WOOD CONSTRUCTION" AND THE TRUSS PLATE INSTITUTE (TPI) "DESIGN SPECIFICATIONS FOR METAL-PLATE-CONNECTED WOOD TRUSSES."
- WOOD TRUSS DESIGN LOADS SHALL BE AS FOLLOWS:
A) TOP CHORD LOADING:
LIVE LOAD = 20 PSF
DEAD LOAD = 10 PSF (PLUS ADDITIONAL 5 PSF AT SUPERIMPOSED ROOF FRAMING AREAS).
WIND LOAD = NET UPLIFT REACTIONS, USE MAXIMUM RESISTING DEAD LOAD = 9 PSF TOTAL.
B) BOTTOM CHORD LOADING:
LIVE LOAD = AS REQUIRED BY NORTH CAROLINA STATE BUILDING CODE, LATEST EDITION.
DEAD LOAD = 10 PSF
TRUSS DESIGN BASED ON BOTTOM CHORD IS NOT BRACED BY THE CEILING.
- SUBMIT SHOP DRAWINGS AND CALCULATIONS PREPARED AND SEALED BY A PROFESSIONAL ENGINEER REGISTERED IN THE STATE OF NORTH CAROLINA FOR THE DESIGN OF PREFABRICATED METAL-PLATE-CONNECTED WOOD TRUSSES. DESIGN INFORMATION SHALL INCLUDE DESIGN LOADINGS AND REACTIONS APPLIED TO THE SUPPORTION STRUCTURE. PROVIDE TRUSS UPLIFT REACTIONS FOR WIND FORCES SECONDARY BENDING STRESSES IN TRUSS TOP AND BOTTOM CHORDS DUE TO LOADS SHALL BE CONSIDERED IN THE DESIGN. THE CONTRACTOR SHALL PROVIDE TRUSS LAYOUT DRAWINGS SEALED BY A PROFESSIONAL ENGINEER FOR REVIEW AND APPROVAL. INCLUDE ALL TRUSS SPLICE DETAILS AND TRUSS TO TRUSS CONNECTION DETAILS.
- WOOD TRUSS FRAMING MEMBERS SHALL COMPLY WITH PS 20 "AMERICAN SOFTWOOD LUMBER STANDARD" AND THE FOLLOWING REQUIREMENTS:
A) SPECIES - SOUTHERN PINE GRADED UNDER SPIB RULES.
B) GRADE - NO. 2 MIN.
C) MOISTURE CONTENT - SEASONED, WITH 19 PERCENT MAXIMUM MOISTURE CONTENT.
D) SIZE - TOP AND BOTTOM CHORDS MINIMUM 2X6 WEBS - SIZE AS REQUIRED.
- WHERE MULTIPLE TRUSSES ARE INDICATED, SCAB TRUSS MEMBERS TOGETHER WITH 16d NAILS AT 12" ON CENTER, OR AS INDICATED ON TRUSS SHOP DRAWINGS. PROVIDE SAME NUMBER OF SUPPORT STUDS AS NUMBER OF MULTIPLE TRUSS PLIES.
- TRUSS MANUFACTURER MAY USE ALTERNATIVE TRUSS WEB CONFIGURATIONS SUBJECT TO APPROVAL OF THE ENGINEER.
- THE CONTRACTOR SHALL PROVIDE ALL TEMPORARY AND PERMANENT BRACING AS REQUIRED FOR SAFE ERECTION OF THE TRUSSES, OR AS RECOMMENDED BY THE MANUFACTURER. THE GUIDELINES SET FORTH IN THE TRUSS PLATE INSTITUTE PUBLICATION "BRACING WOOD TRUSSES, COMMENTARY AND RECOMMENDATIONS" SHALL BE CONSIDERED AS MINIMUM REQUIREMENTS.
- METAL CONNECTOR PLATES SHALL COMPLY WITH ASTM A 446, GRADE A WITH COATING AS SPECIFIED.
- METAL FRAMING ANCHORS SHALL COMPLY WITH ASTM A 448 GRADE A (STRUCTURE QUALITY), OR MANUFACTURER'S PUBLISHED LOADS FOR REFERENCED ITEMS.

FIELD VERIFY ALL DIMENSIONS BEFORE ORDERING TRUSSES.

PRE-ENGINEERED AND MANUFACTURED WOOD ROOF TRUSSES, 24" O.C., DESIGNED IAW CURRENT NC BUILDING CODES AND SEALED BY NC LICENSED ENGINEER.

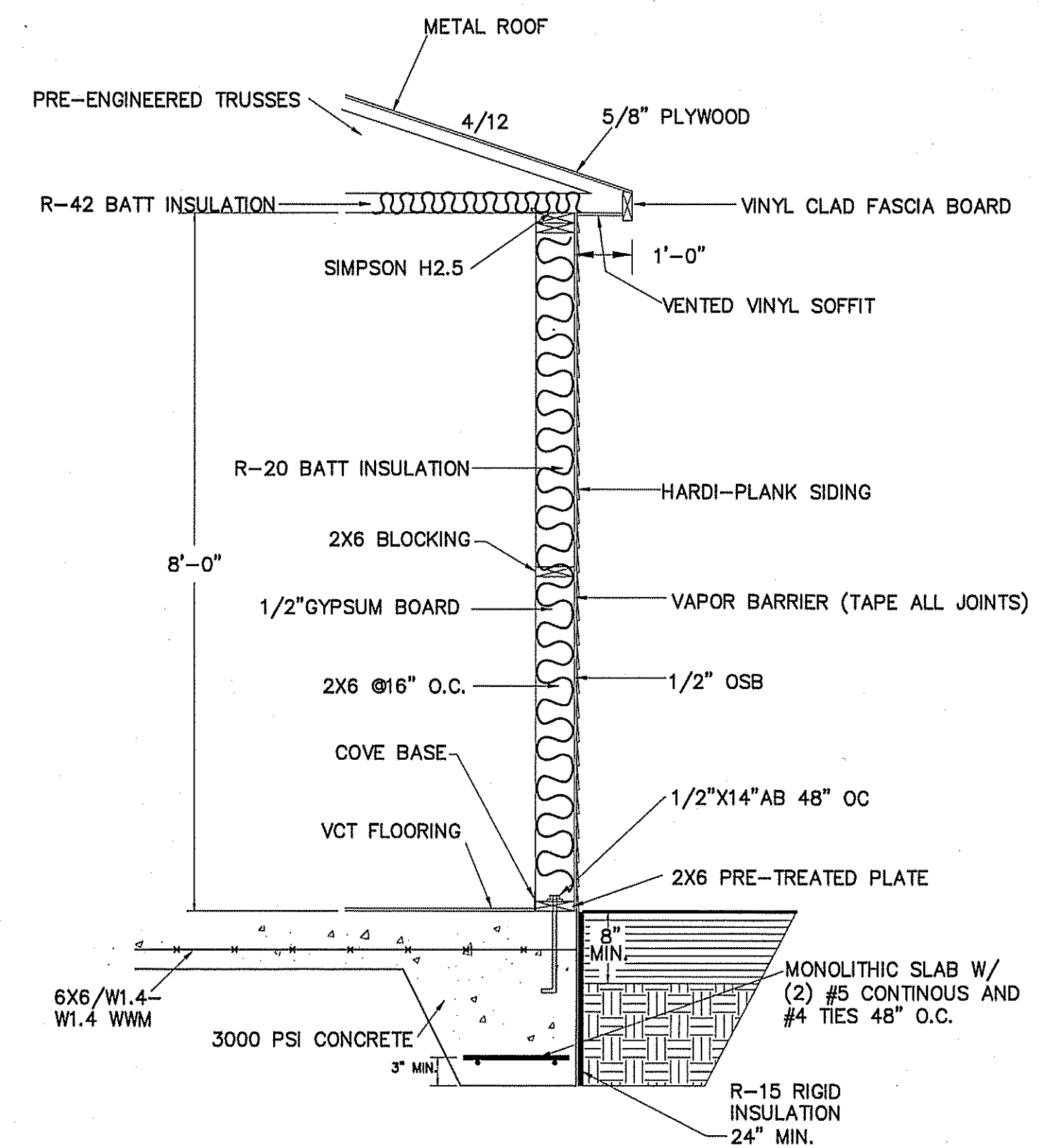

1 EXTERIOR WALL SECTION
F-2 NOT TO SCALE

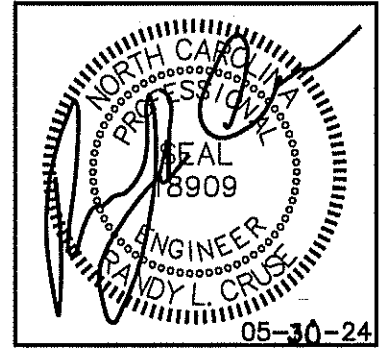

PLANS FOR:
AMPLE STORAGE APARTMENT
JACKSON BOULEVARD-U.S. HIGHWAY 421
ERWIN, NORTH CAROLINA 28339

NO.	REVISIONS

414 E. Edgerton St.
Durham, NC 27604
Phone: (919) 882-3162
Fax: (919) 882-3162

Cruse And Associates, P.A.

THESE DOCUMENTS ARE INSTRUMENTS OF SERVICE AND AS SUCH THESE DRAWINGS, DESIGN, AND DESIGN CONCEPTS PRESENTED REMAIN THE PROPERTY OF THE ENGINEER. PUBLISH OR DUPLICATE THE DRAWINGS OR DESIGN ONLY WITH THE WRITTEN PERMISSION OF THE ENGINEER.
© COPY RIGHT

DATE 05-30-24
DRAWN BY BAM
JOB NO. 24-28

SHEET NO.
F-2 OF 3

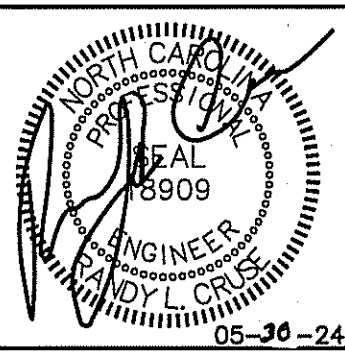

VERIFY ALL EXTERIOR COLORS AND FINISHES WITH OWNER BEFORE BEGINNING CONSTRUCTION.



SIDE ELEVATION
SCALE: 1/4" = 1'-0"

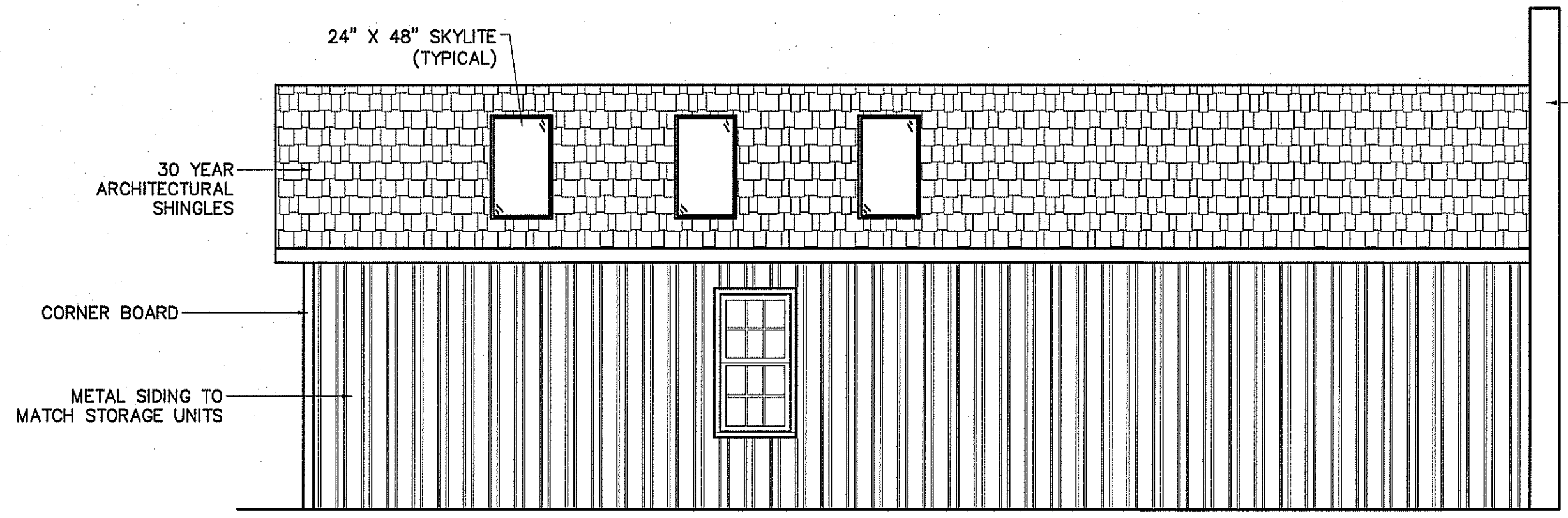

REAR ELEVATION
SCALE: 1/4" = 1'-0"

4 HOUR MASONRY WALL (U907)

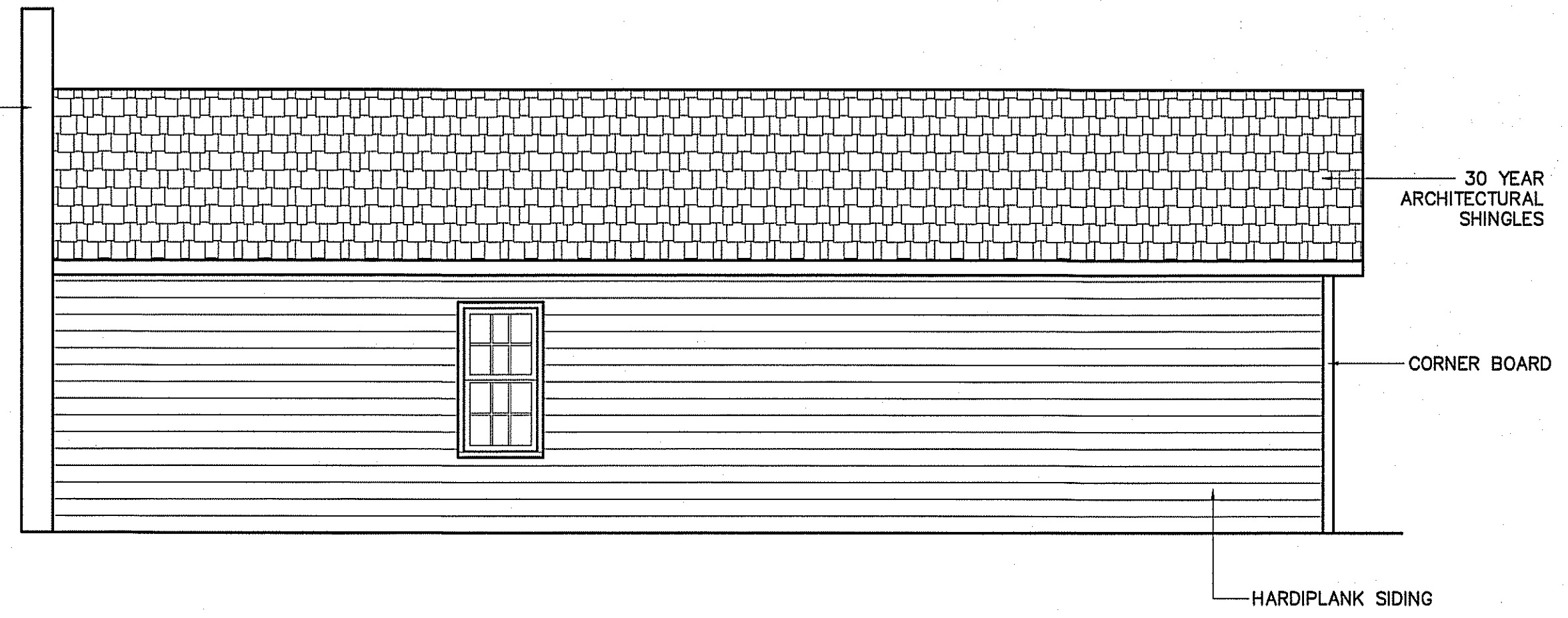

FRONT ELEVATION
SCALE: 1/4" = 1'-0"

PLANS FOR:
AMPLE STORAGE APARTMENT
JACKSON BOULEVARD-U.S. HIGHWAY 421
ERWIN, NORTH CAROLINA 28339

REVISIONS	
NO.	

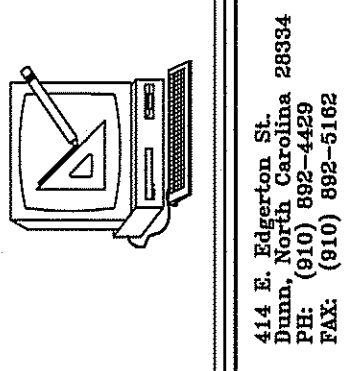

Cruse and Associates, P.A.
144 E. Robertson St.
Durham, North Carolina 28334
TEL: (919) 862-5182
FAX: (919) 862-5182

THESE DOCUMENTS ARE INSTRUMENTS OF SERVICE AND AS SUCH THESE DRAWINGS, DESIGNS, AND DESIGN CONCEPTS PRESENTED REMAIN THE PROPERTY OF THE ENGINEER. PUBLISH OR DUPLICATE THE DRAWINGS OR DESIGNS ONLY WITH THE WRITTEN PERMISSION OF THE ENGINEER.
© COPY RIGHT

DATE 05-30-24
DRAWN BY BAM
JOB NO. 24-28

SHEET NO.
F-3 OF 3

PLUMBING FIXTURE SCHEDULE

MARK	MAKE	MODEL	DESCRIPTION	NOTES
P-1	AMERICAN STANDARD	CADET 207AA.104	EL. 1.6/PA 16.5" HC ELONGATED WATER CLOSET HC ACCESSIBLE, TANK TYPE	WHITE 5214.210 SEAT
P-2	AMERICAN STANDARD	AQUALYN 0476.028.021	SELF-RIMMING COUNTERTOP LAVATORY	AMERICAN STANDARD 1340M.105 SINGLE CONTROL METERING FAUCET W/POP-UP DRAIN
P-3	TUB/SHOWER	TUB & SURROUND BY G.C.	SHOWER & TUB FILLER WITH DIVERTER, DRAIN & PRESSURE BALANCE MIXING VALVE BY PLUMBING CONTRACTOR	
P-4	STAINLESS STEEL DOUBLE BOWL SINK; SINGLE LEVER SWING SPOUT FAUCET, ADA COMPLIANT			
P-5	WASHING MACHINE SUPPLIED BY G.C. AND INSTALLED BY PLUMBER			
P-6	4500 WATT ELECTRIC 50 GALLON WATER HEATER			
P-7	DISHWASHER SELECTED AND PURCHASED BY G.C. AND INSTALLED BY PLUMBER			
P-8	WOODFORD	MOD-65	HOSE BIB FREEZE PROOF	ANTI-SIPHONING WITH VACUUM BREAKER, SELF DRAINING.

* VERIFY ALL FIXTURES WITH OWNER BEFORE PURCHASE OR INSTALLATION

PLUMBING CALCULATIONS

ITEM	# OF	FIXTURE UNITS (EACH)			FIXTURE UNITS (TOTAL)			FIXTURE UNITS (WASTE)
		COLD	HOT	TOTAL	COLD	HOT	TOTAL	
FLUSH TANK WATER CLOSET	1	5.0	-	5.0	5.0	-	5.0	6/6
BATH/SHOWER	1	1.0	1.0	1.4	1.0	1.0	1.4	2/2
LAVATORY	2	1.5	1.5	2.0	3.0	3.0	6.0	2/4
WASHING MACHINE	1	2.25	2.25	3.0	2.25	2.25	3.0	2/2
2 COMP. SINK	1	3.0	3.0	4.0	3.0	3.0	4.0	5/5
N.F.H.B.	1	1.5	-	1.5	1.5	-	1.5	-
TOTAL					15.75	9.25	20.9	19.0

GPM = 19.8
MINIMUM OF 3/4" WATER LINE

→ COME DOWN IN WALL OUTSIDE OF OPENING

PLUMBING CONNECTION SCHEDULE

FIXTURE	C.W.	H.W.	WASTE	VENT
FLUSH VALVE WATER CLOSET	3/8	-	3"	2"
WASHING MACHINE	1/2"	1/2"	2"	2"
LAVATORY	1/2"	1/2"	2"	1 1/2"
FLOOR DRAIN			3"	2"
BATH/SHOWER	1/2"	1/2"	2"	2"
HOSE BIBBS	1/2"	1/2"		
KITCHEN SINKS	1/2"	1/2"	3"	2"

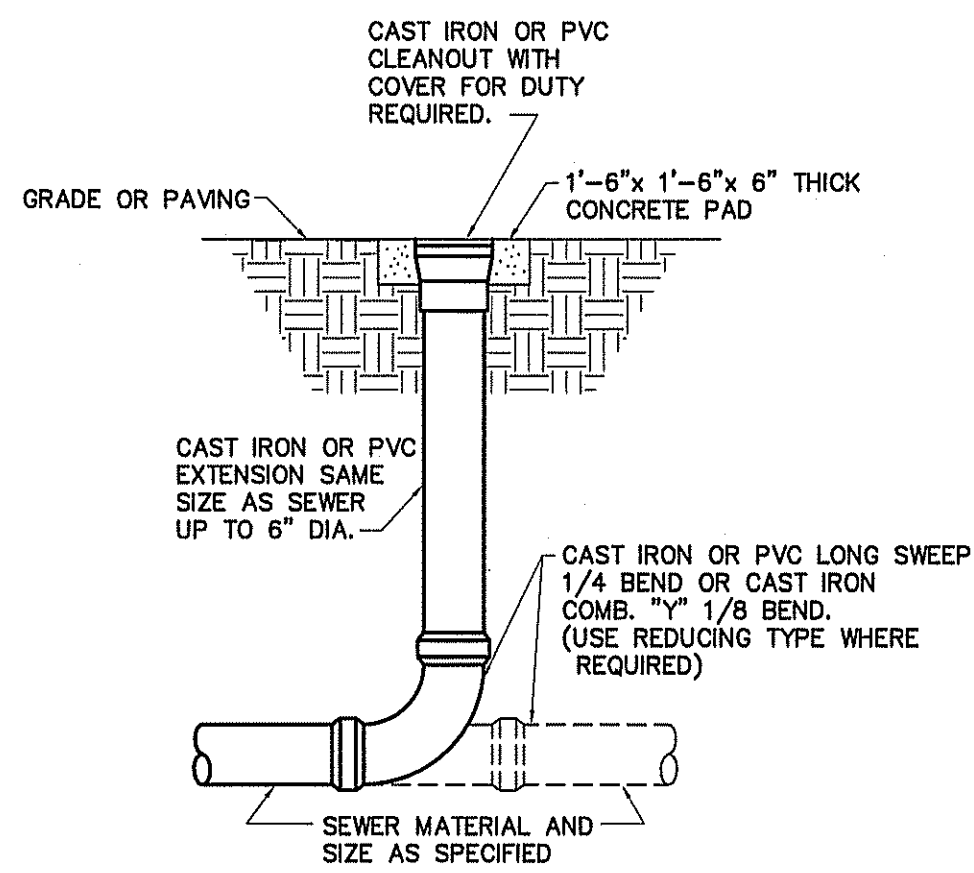

DETAIL-CLEAN OUT AT GRADE

NOT TO SCALE

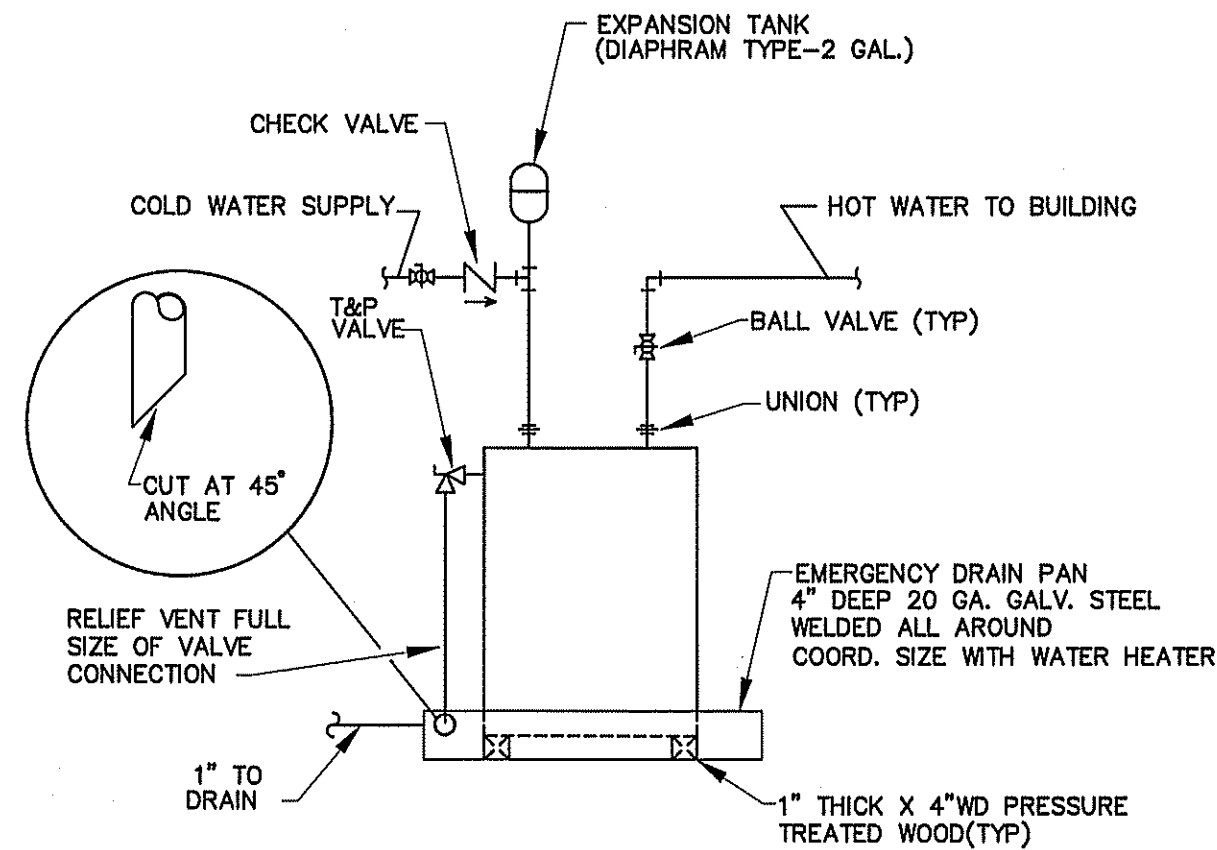

DETAIL-WATER HEATER

NOT TO SCALE

GENERAL PLUMBING NOTES

- ALL WORK SHALL BE IN COMPLIANCE WITH APPLICABLE LOCAL, STATE, AND NATIONAL CODES.
- CONTRACTORS SHALL COORDINATE PIPING WITH ALL OTHER TRADES.
- CONTRACTOR SHALL REFER TO ARCHITECTURAL/STRUCTURAL DRAWINGS FOR DIMENSIONS.
- CONTRACTOR SHALL FURNISH AND INSTALL DIELECTRIC UNIONS AT ALL CONNECTIONS BETWEEN DISSIMILAR METALS.
- CONTRACTOR SHALL FURNISH AND INSTALL ESCUTCHEONS AND COVER PLATES AT ALL FINISHED WALLS, CEILINGS AND FLOOR OPENINGS.
- PIPING SHALL BE DISINFECTED IN ACCORDANCE WITH STATE AND LOCAL CODE. (REFER TO SPECIFICATIONS.)
- ALL PIPING SHALL BE TESTED FOR LEAKS. IF ANY LEAKS ARE DETECTED THE PIPING SHALL BE REPAIRED, RESOLDERED OR REPLACED AND RETESTED.
- ALL SOLDER SHALL BE OF THE LEAD FREE TYPE.
- WATER HEATER SHALL BE SUPPLIED WITH FACTORY INSTALLED T&P VALVES AND SHALL HAVE UNIONS AND ISOLATION VALVES.
- DOMESTIC WATER SUPPLY PIPING SHALL BE CPVC.
- WASTE AND VENT PIPING SHALL BE SCH. 40 PVC OR HEAVY DUTY CAST IRON UNDER TRAFFIC AREAS.
- INSTALL THERMOSTATICALLY CONTROLLED MIXING VALVES AS NEEDED TO ENSURE HOT WATER TEMPERATURE TO ALL HAND WASHING LOCATIONS DOES NOT EXCEED 110°F.
- ALL FLOOR DRAINS & HUB DRAINS SHALL BE PROVIDED WITH TRAP PRIMER EXCEPT FLOOR DRAINS IN TOILETS WHERE HOSE BIBBS ARE PROVIDED.
- HOT WATER PIPING SHALL BE INSULATED WITH 1" THICK FIBROUS GLASS INSULATION. COLD WATER PIPING SHALL BE INSULATED WITH 1/2" FIBROUS GLASS INSULATION. VAPOR BARRIER SHALL BE APPLIED TO EACH.

PLUMBING LEGEND

DESCRIPTION	SYMBOL
COLD WATER	— CW
HOT WATER	— HW
COLD WATER (FILTERED)	— L
RECIRCULATED WATER	— HWR
VENT PIPING	— V
WASTE PIPING	— NEW — EXISTING — W
CLEAN OUT IN GRADE	□ C.O.I.G.
FLOOR CLEAN OUT	○ F.C.O.
NON FREEZE HOSE BIBB	— NFHB
FLOOR DRAIN	○ F.D.
CHECK VALVE	—
BALL VALVE	—
GATE VALVE	—
SHUT-OFF VALVE	—
BACKFLOW PREVENTER	—
FIXTURE DESIGNATION	P---
MOUNTING HEIGHT	MH
POINT OF CONNECTION NEW TO EXISTING	—
FLOOR SINK	—
SHOCK ABSORBER W/BALL VALVE SHUT-OFF	— SA SIZE PER MANUF. RECOMMENDATIONS
CHANGE IN PIPE SIZE	—

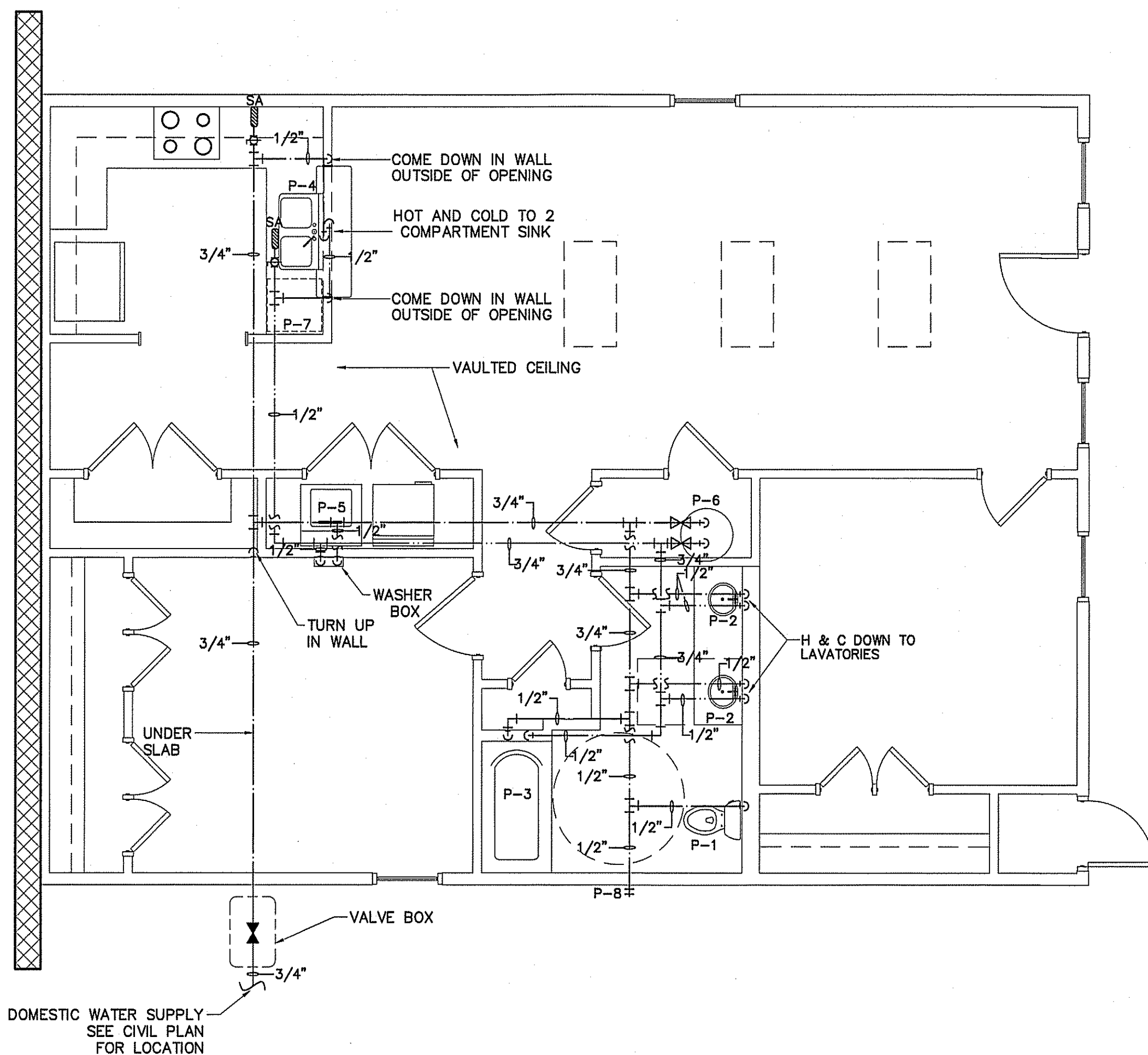

PLUMBING SUPPLY PIPING PLAN

SCALE: 1/4" = 1'-0"

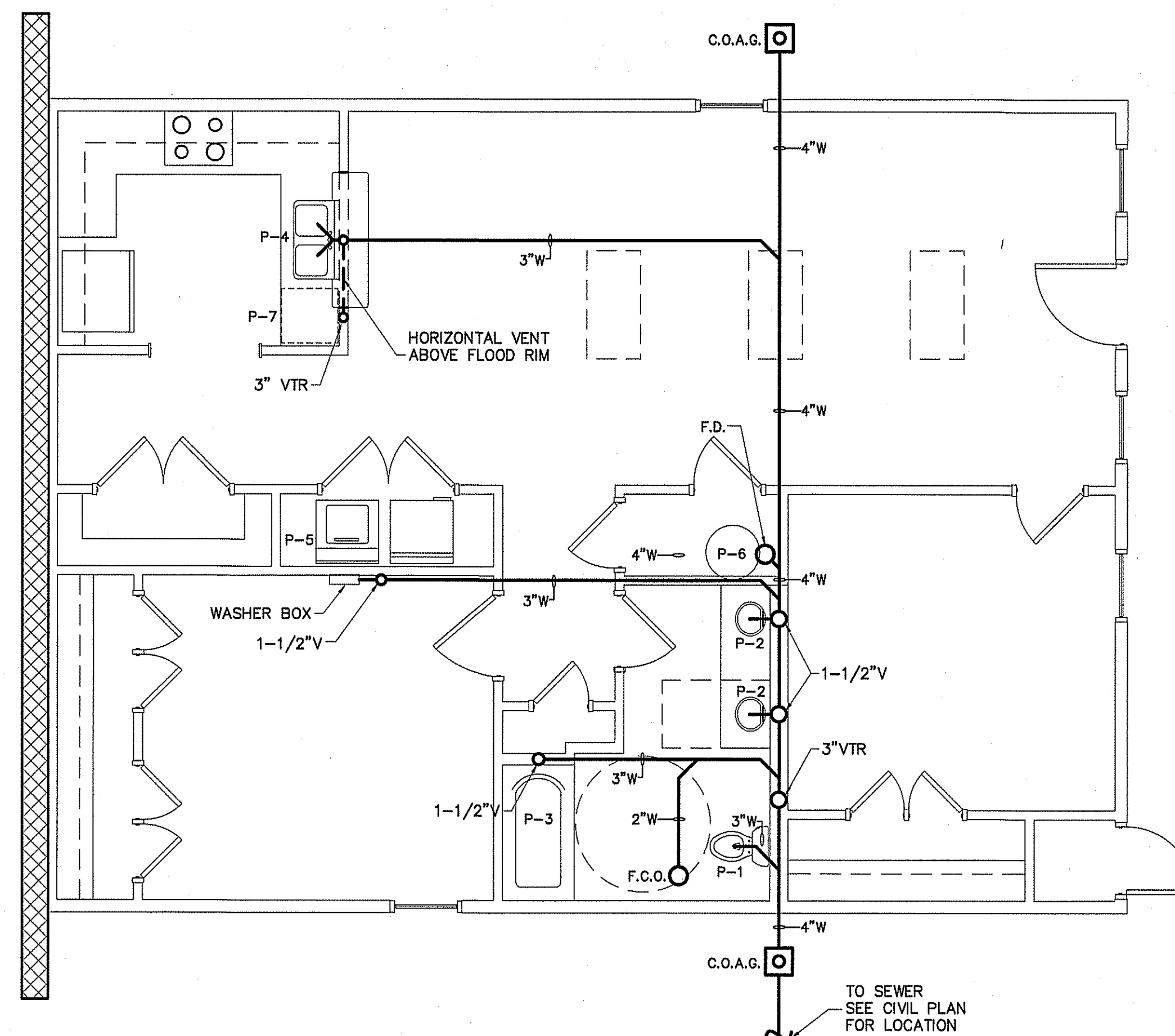

PLUMBING WASTE & VENT PIPING PLAN

SCALE: 1/4" = 1'-0"

LEGEND

4 HOUR RATED FIRE BARRIER WALL U907

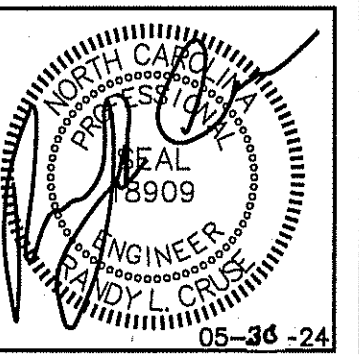

PLANS FOR:
AMPLE STORAGE APARTMENT
JACKSON BOULEVARD-U.S. HIGHWAY 421
ERWIN, NORTH CAROLINA 28339

REVISIONS

NO.	

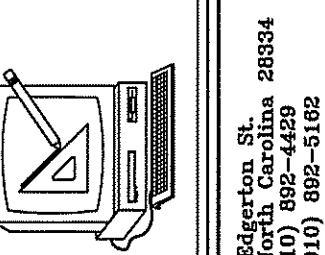

Cruse and Associates, P.A.
144 E. Robertson St.
Durham, North Carolina 27604
Phone: (919) 286-5188
Fax: (919) 286-5188

THESE DOCUMENTS ARE INSTRUMENTS OF SERVICE AND AS SUCH THESE DRAWINGS, DESIGNS, AND DESIGN CONCEPTS PRESENTED REMAIN THE PROPERTY OF THE ENGINEER. PUBLISH OR DUPLICATE THE DRAWINGS OR DESIGNS ONLY WITH THE WRITTEN PERMISSION OF THE ENGINEER.
© COPY RIGHT

DATE 05-30-24

DRAWN BY BAM

JOB NO. 24-28

SHEET NO.

P-1 OF 1

MECHANICAL SYMBOL LEGEND

SINGLE LINE	DOUBLE LINE	DESCRIPTION	SINGLE LINE	DOUBLE LINE	DESCRIPTION	SINGLE LINE	DOUBLE LINE	DESCRIPTION
		TAKE OFF TO SUPPLY AIR REGISTER WITH EXT. INSUL. DUCTWORK			VOLUME CONTROL DAMPER (TYP) FLEXIBLE DUCTWORK (14' MAX.)			SUPPLY AIR CEILING DIFFUSER, ARROW INDICATES DIRECTION OF BLOW & ACTIVE DIFFUSER SIDES
		END CAP DUCT SMOKE DETECTOR			ONE SIDED REDUCING TRANSITION F.D.—FIRE DAMPER (1-1/2)=RATED FOR 1-1/2 HRS.			RETURN AIR OR EXHAUST GRILLE MANUAL VOLUME CONTROL DAMPER W/ QUADRANT LOCKING DEVICE
		ACCESS DOOR DOOR SIZE DUCT HEIGHT 8x8 10" 10x10 12" 12x12 14" & LARGER			TWO SIDED TRANSITION			EXHAUST FAN

NOTE:
VERIFY THERMOSTAT LOCATION WITH OWNER PRIOR TO INSTALLING.

GENERAL NOTE:
MAINTAIN MANUFACTURER'S REQUIRED CLEARANCES FOR ALL HVAC EQUIPMENT.

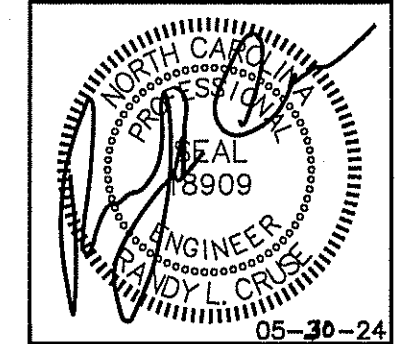

AIR HANDLER UNIT													SPLIT SYSTEM HEAT PUMP UNITS													
AHU NO.	MANUFACTURER	MODEL	VOLTAGE	E.S.P.	OUTSIDE AIR (CFM)	CFM	UNIT FLA	REF LINES		SEER	HTR KW (240)	COOLING CAPACITY (MBH)		HEATING CAPACITY (MBH)		HSPF	MIN. CIRC. AMPACITY	M.O.C.P.	MARK	MANUF.	MODEL	VOLTAGE	# COMP.	MIN. CIRC. AMPACITY	M.O.C.P.	UNIT FLA.
								GAS	LIQ.			TOTAL	SENS.	HIGH	LOW											
AHU-1	TRANE	TEM6A0B24H21	240/1ϕ/60	.46	100	800	32.0	3/4"	3/8"	16.0	7.68	24.2	18.1	22.0	-	9.0	43	45	HP-1	TRANE	4TWR6024N1000A	240/1/60	1	15	25	12.4

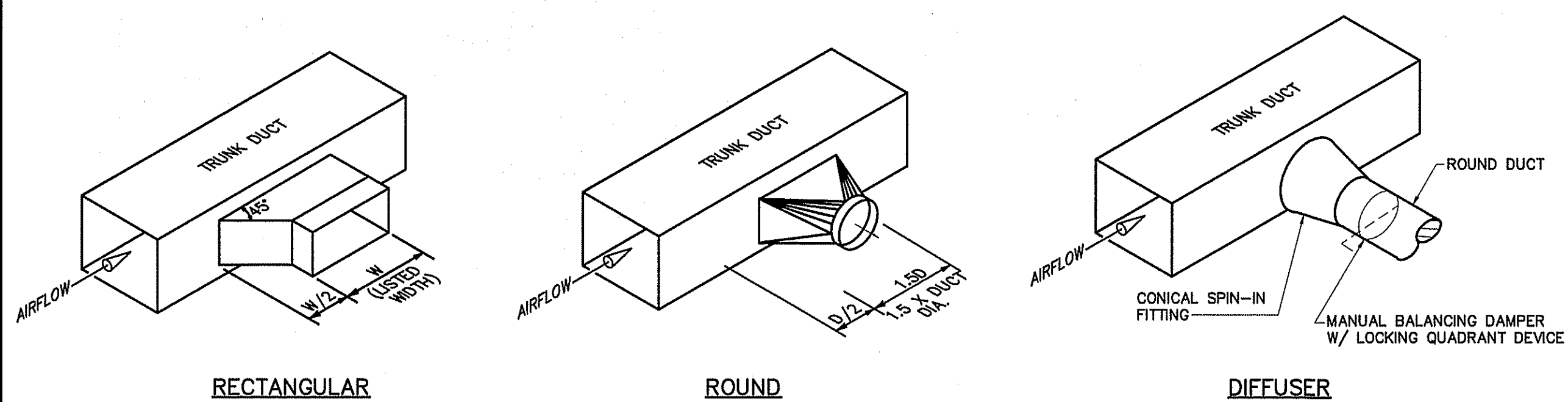

TYPICAL LATERAL TO REGISTER OR BRANCH DUCT
NOT TO SCALE

REGISTER, GRILLE, & DIFFUSER SCHEDULE***										
MARK	DESCRIPTION	MAX. NC	SIZE	MODULE SIZE	BORDER TYPE	MATERIAL	FINISH	MANUFACTURER	MODEL NUMBER	ACCESSORIES / NOTES
A	SUPPLY	30	10X8	NA	SURFACE MOUNT	STEEL	WHITE	HART & COOLEY	631	
B	SUPPLY	30	12X16	NA	SURFACE MOUNT	STEEL	WHITE	HART & COOLEY	821	
R1	RETURN GRILLE	30	18X18	NA	SURFACE MOUNT	STEEL	WHITE	HART & COOLEY	RH45	PROVIDE THROW-AWAY FILTER

*** FIELD VERIFY ALL CAVITY SIZES TO DETERMINE IF TOP MOUNT OR SIDE MOUNT PLENUMS ARE REQUIRED. CUSTOM PLENUMS REQUIRED WHERE FRAMING LIMITS SPACE.

KEYNOTE:

- 1 PROVIDE 6" O.A. DUCT WITH MANUAL VOLUME DAMPER UP TO ROOF CAP.

METHOD OF COMPLIANCE:

PRESCRIPTIVE ENERGY COST BUDGET

THERMAL ZONE 4A - HARNETT COUNTY, NC

EXTERIOR DESIGN CONDITIONS

WINTER DRY BULB 16 DEG. F.
SUMMER DRY BULB 93 DEG. F.

INTERIOR DESIGN CONDITIONS

WINTER DRY BULB 70 DEG. F.
SUMMER DRY BULB 75 DEG. F.

RELATIVE HUMIDITY 60%

BUILDING HEATING LOAD 3 MBH

BUILDING COOLING LOAD 2 TONS

MECHANICAL SPACE CONDITIONING SYSTEM

UNITARY—COOLING — 16.0 SEER
HEATING — 9.0 HSPF

BOILER—NOT APPLICABLE IN THIS PROJECT

CHILLER—NOT APPLICABLE IN THIS PROJECT

LIST EQUIPMENT EFFICIENCIES

EQUIPMENT SCHEDULES WITH MOTORS (MECHANICAL SYSTEMS)

MOTORS USED ON THIS PROJECT ARE INCLUDED IN THE EFFICIENCY RATING OF THE UNIT. SEE PLANS FOR EFFICIENCIES.

MECHANICAL NOTES (GENERAL)

1. DUCTWORK LAYOUTS ARE SCHEMATIC. ALL RISES, DROPS, OFFSETS, AND TRANSITIONS REQUIRED BUT ARE NOT SHOWN SHALL BE PROVIDED AND INSTALLED BY THE CONTRACTOR AT NO ADDITIONAL EXPENSE TO THE OWNER.
2. DUCTWORK SHALL BE GALVANIZED STEEL AND SHALL BE CONSTRUCTED IN COMPLIANCE WITH SMACNA STANDARDS FOR LOW VELOCITY DUCTWORK. DUCT SIZES SHOWN ARE INSIDE CLEAR DIMENSIONS. FLEXIBLE RUNOUTS SHALL NOT EXCEED 15' AND SHALL NOT BE USED TO FORM ELBOWS. CONNECTIONS FROM RECTANGULAR TO ROUND DUCT SHALL BE MADE WITH MANUFACTURED 45 DEG. LATERAL TAPS.
3. SUPPLY AND RETURN DUCTWORK SHALL BE INSULATED WITH FIBERGLASS INSULATION WITH A MINIMUM THERMAL RESISTANCE OF R-8.0 (IN UNCONDITIONED AREAS) AND AN "FSK" VAPOR BARRIER. DIFFUSERS SHALL BE INSULATED WITH FIBERGLASS INSULATION WITH VAPOR BARRIER. ALL JOINTS SHALL BE TAPED WITH A FOIL BACKED TAPE TO PROVIDE A CONTINUOUS VAPOR BARRIER.
4. THE ELECT. CONTRACTOR SHALL SUPPLY, AND MECH. CONTRACTOR SHALL INSTALL A SMOKE DETECTOR IN THE RETURN AIR DUCTWORK, THE EVAPORATOR FAN AND THE COMPRESSOR SHALL BE INTERLOCKED WITH THE SMOKE DETECTORS SO THAT THE COMPRESSOR AND THE EVAPORATOR FAN ARE DE-ENERGIZED WHEN SMOKE IS DETECTED. THE SMOKE DETECTORS SHALL HAVE A SUFFICIENT NUMBER OF CONTACTS TO INTERFACE WITH THE BUILDING FIRE ALARM SYSTEM.
5. ALL DUCTWORK SHALL BE SEALED AIR TIGHT WITH SEALING COMPOUND.
6. THIS CONTRACTOR SHALL COORDINATE HIS WORK WITH THAT OF OTHER TRADES PRIOR TO INSTALLATION OF ANY OF HIS PIPING, DUCTWORK, OR EQUIPMENT.
7. THE MECHANICAL CONTRACTOR SHALL MAKE A COMPLETE REVIEW OF THE MECHANICAL PLANS, SCHEDULES, AND DETAILS PRIOR TO INSTALLATION OF THE MECHANICAL SYSTEMS AND REVIEW ANY CONFLICTS THAT ARE NOTED WITH THE ENGINEER.
8. IT WILL BE THE RESPONSIBILITY OF THE MECHANICAL CONTRACTOR TO ENSURE THAT ITEMS TO BE FURNISHED UNDER HIS CONTRACT WILL FIT THE SPACE AVAILABLE. HE SHALL MAKE NECESSARY FIELD MEASUREMENTS TO ASCERTAIN SPACE REQUIREMENTS, INCLUDING THOSE FOR CONNECTIONS AND SHALL FURNISH AND INSTALL SUCH SIZES AND SHAPES OF EQUIPMENT THAT ARE THE TRUE AND INTENT MEANING OF THE PLANS AND SPECIFICATIONS. HE SHALL PROVIDE THE ENGINEER SCALED DRAWINGS OF ALL MECHANICAL DRAWINGS.
9. ALL EQUIPMENT SHALL BE LOCATED AND INSTALLED TO PROVIDE MAXIMUM SPACE FOR MAINTENANCE AND SERVICE.
10. ALL ELBOWS IN DUCTWORK SHALL BE RADIUS ELBOWS, UNLESS NOTED OTHERWISE. WHERE SQUARE ELBOWS ARE SHOWN, INSTALL TURNING VANES.
11. MECHANICAL CONTRACTOR TO FIELD COORDINATE LOCATION OF MECHANICAL SYSTEMS WITH ELECTRICAL AND PLUMBING SYSTEMS. COORDINATE WITH ALL OTHER SYSTEMS AS NECESSARY.
12. MECHANICAL WORK INCLUDES DEMOLITION, RELOCATION, IN EXISTING & NEW WORK AS APPLICABLE. MECHANICAL CONTRACTOR TO SUPPLY A COMPLETE SYSTEM IN EACH AREA.

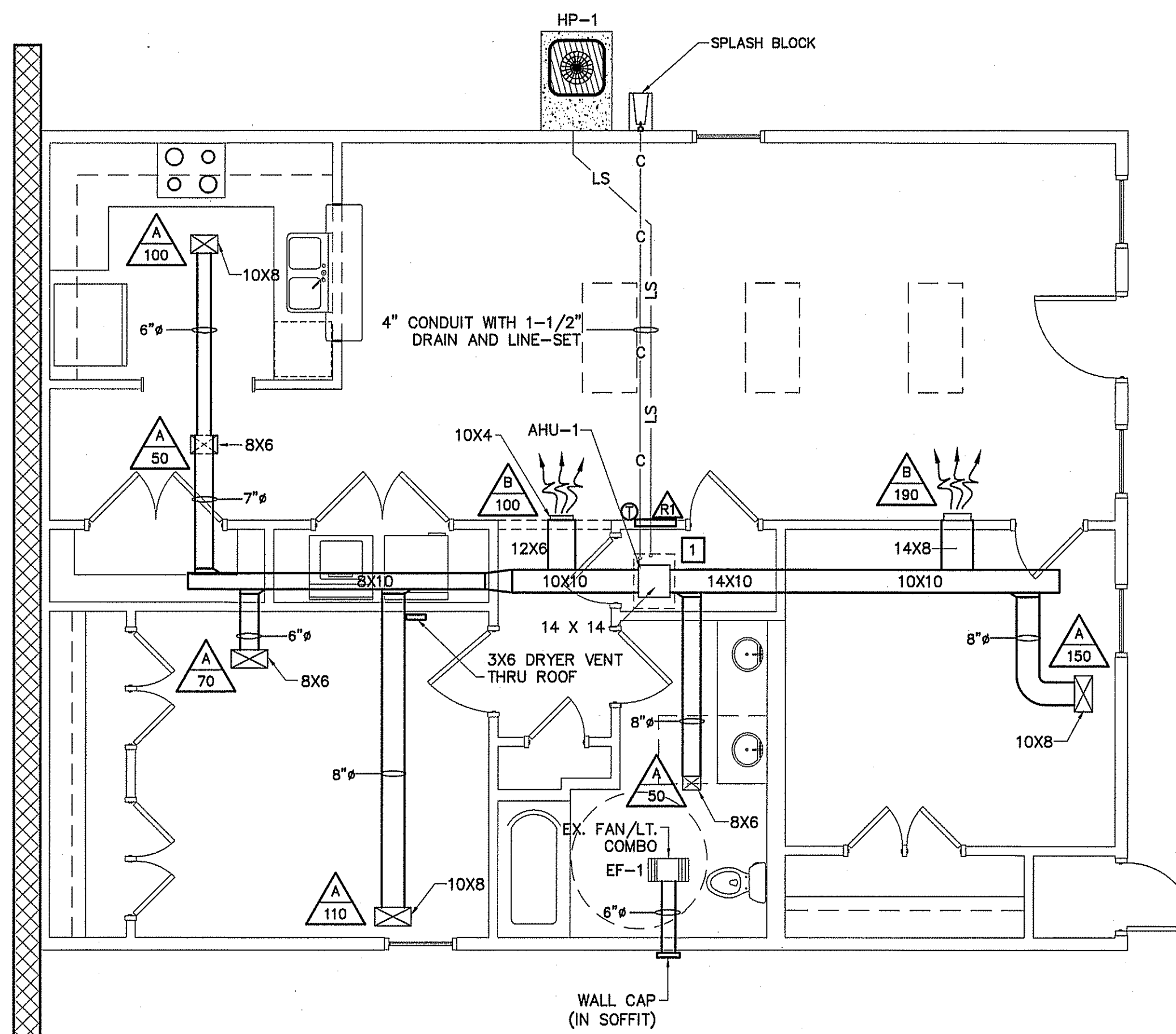

HVAC MECHANICAL HVAC PLAN
SCALE: 1/4" = 1'-0"

CONNECTION SCHEDULE

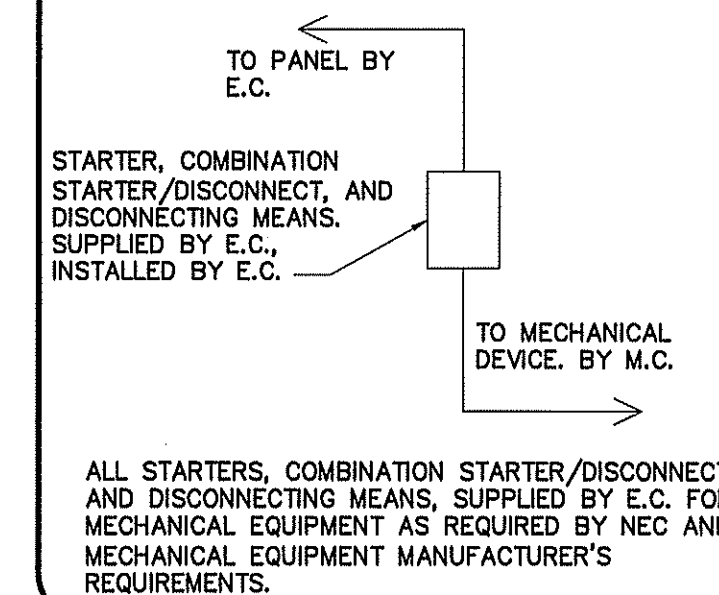

LEGEND

4 HOUR RATED FIRE BARRIER WALL U67

PLANS FOR:
AMPLE STORAGE APARTMENT
JACKSON BOULEVARD—U.S. HIGHWAY 421
ERWIN, NORTH CAROLINA 28339

REVISIONS

NO.	DESCRIPTION

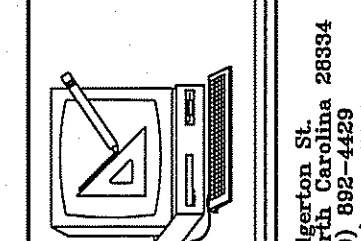

Cruse and Associates, P.A.
 414 E. Edgerton St.
 Raleigh, North Carolina 27601
 Phone: (919) 882-5100
 Fax: (919) 882-5108

THESE DOCUMENTS ARE INSTRUMENTS OF SERVICE AND AS SUCH THESE DRAWINGS, DESIGNS, AND DESIGN CONCEPTS PRESENTED REMAIN THE PROPERTY OF THE ENGINEER. PUBLISH OR DUPLICATE THE DRAWINGS OR DESIGNS ONLY WITH THE WRITTEN PERMISSION OF THE ENGINEER.
 © COPY RIGHT

DATE 05-30-24

DRAWN BY BAM

JOB NO. 24-28

SHEET NO.
M-1 OF 1

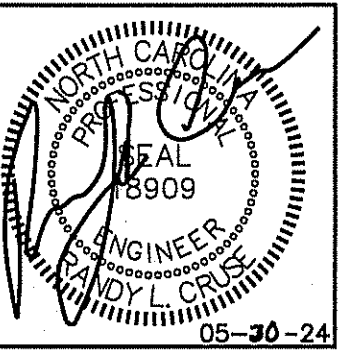

LIGHT FIXTURE SCHEDULE (APARTMENT)							
MARK	DESCRIPTION	MANUFACTURER	CATALOG NUMBER	LAMPS	BALLASTS	WATTAGE	REMARKS
A	WRAPAROUND DIFFUSER	LITHONIA	11852	2-17W T8	1	34	VANITY LIGHT
B	CEILING MOUNTED TASKLIGHT	LITHONIA	11890RE	2-17W T8	1	34	
C	52" WHITE CEILING FAN/LT.	HARBOR BREEZE	E BDB52MWW5BC4	4-FLE11		44	WITH LIGHT KIT
D	4' 2 LAMP FLUORESCENT	PORTFOLIO	APW-GPW232	2-32 T8	1	56	
E	LED CAN LIGHT	HALO	HALO 498W, 6" TRIM BAFFLE SLOPE CEILING TRIM W/WHITE COILEX BAFFLE	LED		15	H47ICAT HOUSING
F	EXHAUST FAN LIGHT COMBO	HARBOR BREEZE	80206	2-60W A15		120	INCLUDE 1 C7W NIGHT LIGHT BULB
G	NORMA SMALL 9" BLACK INCANDESCENT OUTDOOR WALL LIGHT	HUNTER	M11741	1-60 INC.		60	
H	LED WALLPACK	LITHONIA	TWR1 LED 3 50K MVOLT ON TIMER	18 LEDS	LED	58.4	SEE SITE LIGHTING PLAN FOR OPTIONS & EXACT LOCATIONS

* ALL FIXTURE SELECTIONS TO BE VERIFIED BY OWNER BEFORE PURCHASE. *

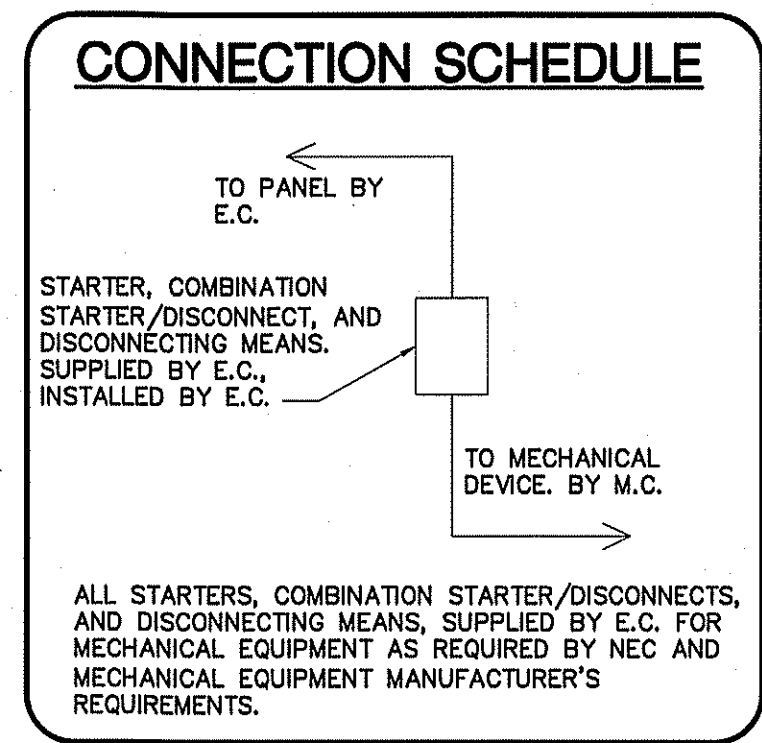

PLANS FOR:
AMPLE STORAGE APARTMENT
 JACKSON BOULEVARD-U.S. HIGHWAY 421
 ERWIN, NORTH CAROLINA 28339

REVISIONS	
NO.	

Cruse And Associates, P.A.
 414 E. Ragsdale St., 28384
 Erwin, N.C. 28339
 TEL: (910) 882-4489
 FAX: (910) 882-5168

THESE DOCUMENTS ARE INSTRUMENTS OF SERVICE AND AS SUCH THESE DRAWINGS, DESIGNS, AND DESIGN CONCEPTS PRESENTED REMAIN THE PROPERTY OF THE ENGINEER. PUBLISH OR DUPLICATE THE DRAWINGS OR DESIGNS ONLY WITH THE WRITTEN PERMISSION OF THE ENGINEER.
 © COPY RIGHT

DATE 05-30-24
 DRAWN BY BAM
 JOB NO. 28-28

SHEET NO.
E-1 OF 2

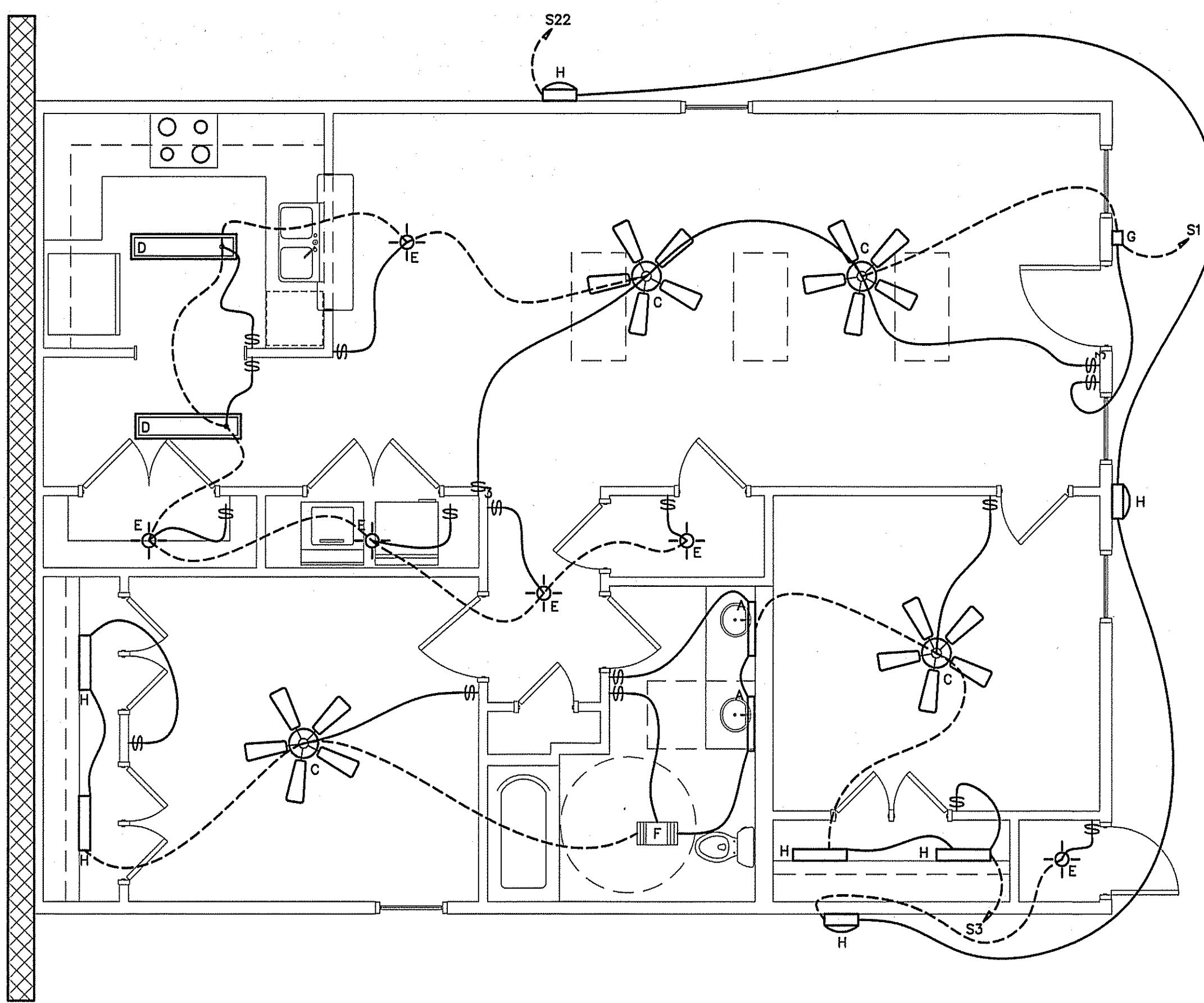

ELECTRICAL LIGHTING PLAN (APARTMENT)
 SCALE: 1/4" = 1'-0"

ELECTRICAL LEGEND	
MARK	DESCRIPTION
⊕	QUAD RECEPTACLE
⊕	DUPLEX RECEPTACLE
⊕	SINGLE POLE SWITCH OR TIMER AS APPLICABLE
⊕	HIGH WALL MOUNTED DUPLEX RECEPTACLE APPROXIMATELY 12" BELOW CEILING
⊕	FLUORESCENT FIXTURE
↔	SWITCHED BRANCH CIRCUIT
↔	UNSWITCHED BRANCH CIRCUIT
↔	120/208 VOLT CIRCUIT
⊕	MOTION DETECTING SINGLE-POLE SWITCH ON TIMER
⊕	'EXIT' LIGHT FIXTURE, TYPE 'EX'
⊕	BATTERY OPERATED EMERG. LT. (2-HEAD, WALL MTD.)
⊕	MOTION DETECTING 3-WAY SWITCH (4-WAY SWITCH) WITH TIMER
⊕	FUSED DISCONNECT SWITCH
⊕	CEILING MOUNTED FUSED DISCONNECT SWITCH
⊕	TELEPHONE
⊕	JUNCTION BOX
⊕	SINGLE POLE SWITCH OR TIMER AS APPLICABLE
⊕	UNSWITCHED FIXTURE
⊕	OCCUPANCY SENSING SINGLE-POLE SWITCH NOT ON TIMER
⊕	280V RECEPTACLE
⊕	EMERGENCY LIGHT REMOTE WEATHERHEAD(S)

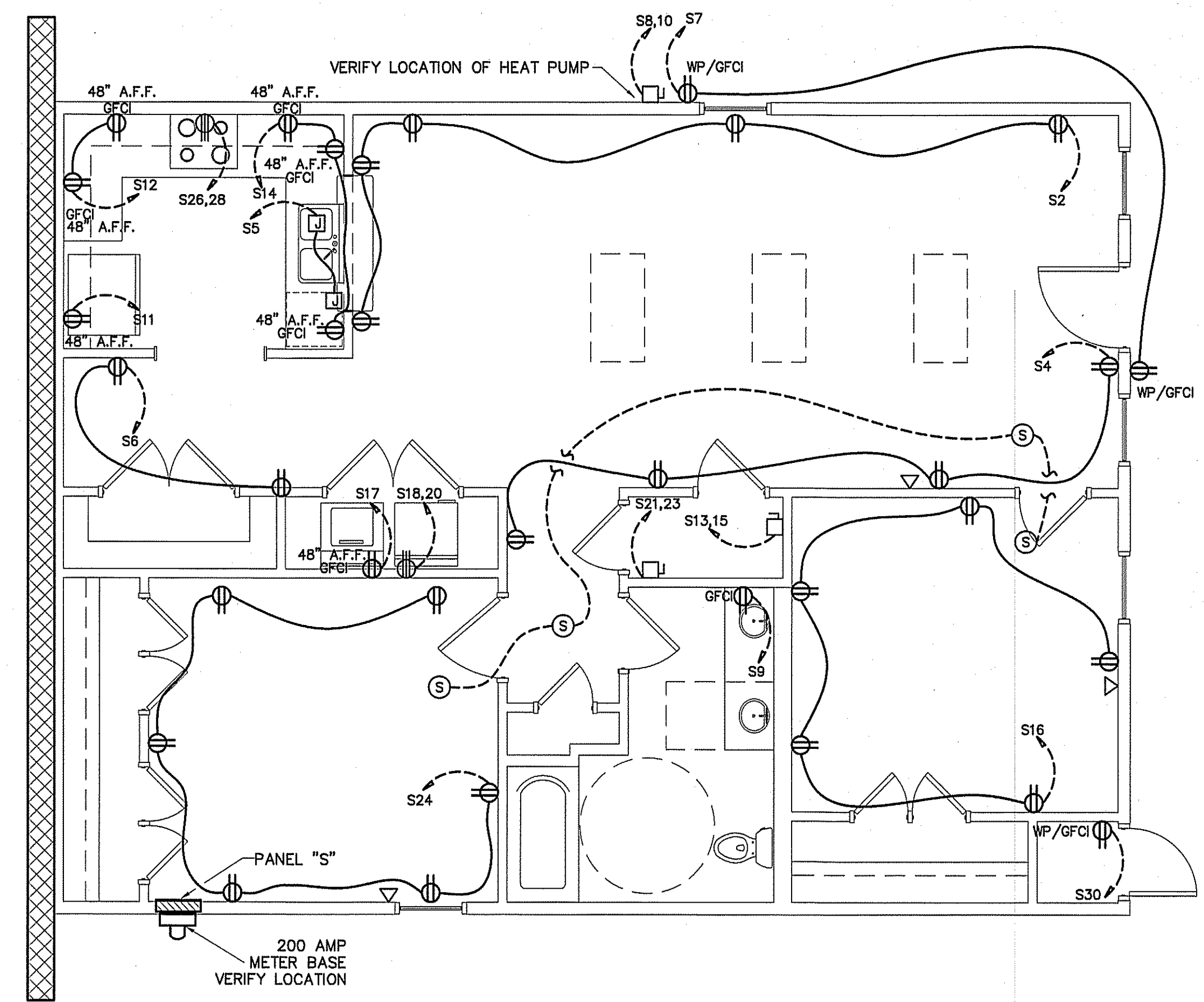
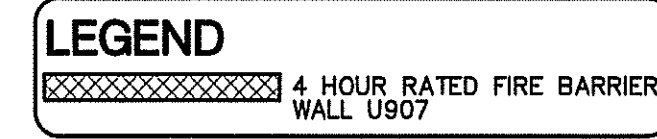

ELECTRICAL POWER PLAN (APARTMENT)
 SCALE: 1/4" = 1'-0"

ELECTRICAL LOAD CALCULATIONS

1200 SQ. FT. @ 3VA =	3600
31 RECEPTACLES AT 180 VA	5580
(2) 20A SMALL APPLIANCE CIRCUITS @ 1500VA EACH	3000
LAUNDRY CIRCUIT	1500
RANGE (NAMEPLATE RATING)	7900
WATER HEATER	4500
DISHWASHER	1200
DRYER	4320
TOTAL	31600
FIRST 10kVA @ 100%	10000
REMAINDER OF LOAD @ 40%	
(21600VA X 0.4)	8640
	18640
HEAT PUMP & SUPPLEMENTARY HEAT	
240V X 12.4A	
7.68kW ELECTRIC HEAT	
2976 + (7700VA X 65%) = 8.0 kVA	
2976+5005 VA = 7981VA X (1 UNIT) =	7981
TOTALS:	
NET GENERAL LOAD	18640
HEAT PUMP & SUPPLEMENTARY HEAT	7981
TOTAL	26621
CALCULATED LOAD FOR SERVICE	
26405 VA / 240V = 111 AMPS	

APARTMENT

PANEL: S SCHEDULE: _____ MANUFACTURER: SQ. D NO. OF SPACES: 42
 VOLTS: 120/240 AMPS: 200 TYPE: "NQOD" MOUNTING: FLUSH
 ENCLOSURE: NEMA 1 Ø: 1 SHORT CIRCUIT RATING: 10000
 MARKS: TOP FEED BOTTOM FEED COPPER BUS GROUND BAR KIT: NEUTRAL BAR KIT:

L1	L2	CIRCUIT	POLES	TRIP	ASSIGNMENT	PHASE	ASSIGNMENT	TRIP	POLES	CIRCUIT	L1	L2
X	X	3.7	1	20	APARTMENT LIGHTING	o	LIVING/DINING ROOM RECS.	20	1	2	7.5	
X	X	3.4	3	1	BEDROOM/BATHROOM LIGHTING	o	LIVING ROOM RECEPTACLES	20	1	4		6.0
X	X	12.0	5	1	DISHWASHER/GARBAGE DISP.	o	CONVENIENCE RECEPTACLES	20	1	6	3.0	
X	X	3.0	7	1	EXTERIOR GFCI RECEPTACLES	o	HEAT PUMP 1	25	2	8		12.4
X	X	1.5	9	1	BATHROOM GFCI RECEPTACLE	o				10	12.4	
X	X	8.0	11	1	REFRIGERATOR	o	SMALL APPLIANCE REC.	20	1	12		3.0
X	X	18.8	13	2	WATER HEATER	o	SMALL APPLIANCE REC.	20	1	14	4.5	
X	X	18.8	15				BEDROOM RECEPTACLES	20	1	16		7.5
X	X	5.0	17	1	WASHING MACHINE	o	DRYER	30	2	18	18.0	
X	X	X	19	1	SPARE	o				20		18.0
X	X	32.0	21	2	AIR HANDLER UNIT # 1	o	WALLPACKS/RISER ROOM LT.	20	1	22	1.6	
X	X	32.0	23				MASTER BEDROOM RECEPT.	20	1	24		9.0
X	X	X	25	2	SPARE	o	RANGE	50	2	26	33.0	
X	X	X	27	1	SPARE	o				28		33.0
X	X	X	29	1	SPARE	o	SPRINKLER RISER ROOM REC.	20	1	30	1.5	
X	X	X	31	1	SPARE	o				20	1	32
X	X	X	33	1	SPARE	o				20	1	34
X	X	X	35	1	SPARE	o				20	1	36
X	X	X	37	1	SPARE	o				20	1	38
X	X	X	39	1	SPARE	o				20	1	40
X	X	X	41	1	SPARE	o				20	1	42

L1 = 154.5 A
L2 = 154.1 A

NOTE:
VERIFY AIC RATING & LUG SPACE WITH UTILITY COMPANY BEFORE ORDERING PANELS.

NOTE:
COORDINATE LOCATION OF SECURITY, CATV, INTERNET, PHONE, OR OTHER SYSTEMS OUTLETS WITH OWNER BEFORE BEGINNING CONSTRUCTION.

ELECTRICAL SYSTEM AND EQUIPMENT METHOD OF COMPLIANCE:
 ENERGY CODE: PRESCRIPTIVE PERFORMANCE
 ASHRAE 90.1: PRESCRIPTIVE PERFORMANCE

REFER TO DRAWINGS FOR RISER DIAGRAM AND PANEL SCHEDULES
LIGHTING SCHEDULE
 LAMP TYPE REQUIRED IN FIXTURE: SEE SCHEDULE

NUMBER OF LAMPS IN FIXTURE:
 BALLASTS TYPE USED IN FIXTURE:
 NUMBER OF BALLASTS IN FIXTURE:
 TOTAL WATTAGE PER FIXTURE:
 TOTAL INTERIOR WATTAGE SPECIFIED VS. ALLOWED:
 TOTAL EXTERIOR WATTAGE SPECIFIED VS. ALLOWED:
ADDITIONAL PRESCRIPTIVE COMPLIANCE
 506.2.1 MORE EFFICIENT MECHANICAL EQUIPMENT
 506.2.2 REDUCED LIGHTING POWER DENSITY
 506.2.3 ENERGY RECOVERY VENTILATION SYSTEMS
 506.2.4 HIGHER EFFICIENCY SERVICE WATER HEATING
 506.2.5 ON-SITE SUPPLY OF RENEWABLE ENERGY
 506.2.6 AUTOMATIC DAYLIGHTING CONTROL SYSTEMS

FEEDER SCHEDULE

UNIT	FEEDERS	FUSED DISCONNECT	CONDUIT
AIR HANDLER 1	2#BCU,1#10CU GND	60	3/4"
HEAT PUMP 1	2#10CU,1#12CU GND	30	3/4"
WATER HEATERS	2#10CU,1#12CU GND	30	3/4"
RANGE	2#BCU,1#8CU GND	60	3/4"

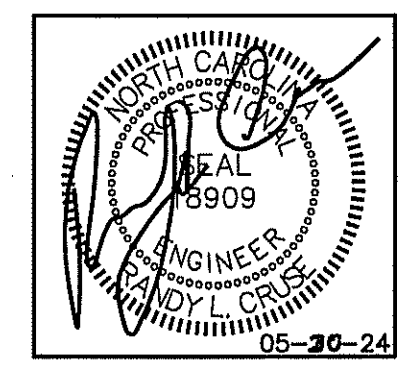

PLANS FOR:
 AMPLE STORAGE APARTMENT
 JACKSON BOULEVARD-U.S. HIGHWAY 421
 ERWIN, NORTH CAROLINA 28339

REVISIONS

NO.	

Cruse And Associates, P.A.
 514 E. Walnut Street, Suite 28304
 Raleigh, NC 27601
 TEL: (919) 882-4429
 FAX: (919) 882-5122

THESE DOCUMENTS ARE INSTRUMENTS OF SERVICE AND AS SUCH THESE DRAWINGS, DESIGNS, AND DESIGN CONCEPTS PRESENTED REMAIN THE PROPERTY OF THE ENGINEER. PUBLISHED OR DUPLICATED DRAWINGS OR DESIGNS ONLY WITH THE WRITTEN PERMISSION OF THE ENGINEER.
 © COPY RIGHT

DATE: 05-30-24
 DRAWN BY: BAM
 JOB NO.: 24-28
 SHEET NO.: E-2 OF 2

- ELECTRICAL NOTES (GENERAL)**
- THE ELECTRICAL INSTALLATION, EQUIPMENT, MATERIALS, AND WORKMANSHIP SHALL, AS A MINIMUM, BE IN ACCORDANCE WITH THE REQUIREMENTS OF THE NATIONAL ELECTRICAL CODE (NEC), OCCUPATIONAL SAFETY AND HEALTH ACT (OSHA), ALL APPLICABLE FEDERAL, STATE, COUNTY, AND LOCAL CODES, LAWS, AND ORDINANCES, AND RULINGS OF THE INSPECTION AUTHORITIES HAVING JURISDICTION. ALL FEES, PERMITS, ETC., ASSOCIATED WITH THE ELECTRICAL WORK SHALL BE THE RESPONSIBILITY OF THE ELECTRICAL CONTRACTOR.
 - THE DRAWINGS GENERALLY INDICATE THE WORK TO BE INSTALLED, BUT DO NOT SHOW ALL BENDS, BOXES, FITTINGS, AND SPECIALTIES WHICH MAY BE REQUIRED FOR A COMPLETE INSTALLATION. ALL SUCH ITEMS REQUIRED TO COMPLETE THE INSTALLATION ACCORDING TO INDUSTRY ACCEPTED PRACTICES SHALL BE INCLUDED IN THE BID.
 - ALL EQUIPMENT AND MATERIALS SHALL BE NEW AND LISTED AND LABELED BY UNDERWRITERS LABORATORIES, INC.
 - THE ELECTRICAL CONTRACTOR SHALL COORDINATE ALL WORK WITH OTHER TRADES TO AVOID INTERFERENCES AND CONFLICTS. APPARENT INTERFERENCES OR CONFLICTS SHALL BE REPORTED TO THE PRIME CONTRACTOR AND RESOLVED PRIOR TO PROCEEDING WITH THE WORK IN QUESTION.
 - THE ELECTRICAL CONTRACTOR SHALL CONNECT BRANCH CIRCUITS TO THE MAIN LINE TERMINALS OF EQUIPMENT FURNISHED BY OTHER CONTRACTORS. THE ELECTRICAL CONTRACTOR SHALL BE RESPONSIBLE FOR PROVIDING AND INSTALLING ANY NECESSARY SWITCHES, DISCONNECTS, OR OVERCURRENT PROTECTION AHEAD OF SUCH EQUIPMENT.
 - RACEWAYS ARE SHOWN SCHEMATICALLY AND MAY BE REROUTED IN THE FIELD. THEY SHALL BE INSTALLED AT RIGHT ANGLES TO OR PARALLEL WITH BUILDING LINES. THEY SHALL BE RUN CONCEALED WITHIN WALLS OR BUILDING STRUCTURES WHEREVER POSSIBLE.
 - THE MINIMUM ALLOWABLE SIZE FOR ANY CONDUIT, IMC, OR EMT SHALL BE 3/4"; 1/2" MAY BE USED FOR SWITCH LEGS.
 - FULL WEIGHT GALVANIZED RIGID STEEL CONDUIT SHALL BE USED IN THE FOLLOWING AREAS:
 - ON THE EXTERIOR OF THE BUILDING OR ROOF.
 - VERTICAL DROPS WHERE THE CONDUIT CANNOT BE ANCHORED TO WALLS OR OTHER SUPPORT STRUCTURES.
 - WHERE SUBJECT TO MECHANICAL DAMAGE.
 - UNDER FLOOR INSTALLATIONS
 - ALL WIRE AND CABLE SHALL BE ALUMINUM OR COPPER AND HAVE 600 VOLT THHN-THWN INSULATION.
 - THE MINIMUM WIRE SIZE SHALL BE #12 AWG EXCEPT FOR CONTROL WIRING, WHICH MAY BE #16 AWG. CONTROL WIRING SHALL USE STRANDED CONDUCTORS UNLESS OTHERWISE NOTED.
 - ALL METAL RACEWAY SYSTEMS SHALL BE MADE ELECTRICALLY CONTINUOUS. THE RACEWAY SYSTEM SHALL NOT BE THE SOLE GROUNDING METHOD. AN INSULATED COPPER GROUNDING CONDUCTOR SHALL BE INSTALLED FOR ALL FEEDERS AND BRANCH CIRCUITS. AT RECEPTACLES, A GREEN GROUND CONDUCTOR SHALL BE CONNECTED TO THE GROUND TERMINAL OF THE RECEPTACLE.
 - ALL CONDUCTORS TO BE INSTALLED IN CONDUIT.
 - ALL PENETRATIONS OF FIRE WALLS SHALL BE SEALED WITH APPROVED SEALING MATERIALS TO MAINTAIN THE FIRE RATING OF THE WALLS IN ACCORDANCE WITH UL PENETRATION DETAIL W-J-1042.
 - NO. 10 CU TO 10 AWG CONDUCTORS SHALL BE USED FOR 20 AMP BRANCH CIRCUIT HOMERUNS EXCEEDING 50 FT. TO THE JUNCTION POINT. 20 AMP BRANCH CIRCUIT WIRING SHALL BE NO. 10 CU AWG THROUGHOUT IF THE CIRCUIT IS LONGER THAN 100 FEET TOTAL LENGTH. 20 AMP BRANCH CIRCUIT WIRING SHALL BE NO. 8 CU AWG THROUGHOUT IF THE CIRCUIT IS LONGER THAN 200 FEET TOTAL LENGTH. 20 AMP BRANCH CIRCUIT WIRING SHALL BE NO. 6 CU AWG THROUGHOUT IF THE CIRCUIT IS LONGER THAN 400 FEET TOTAL LENGTH. 20 AMP BRANCH CIRCUIT SHALL BE NOT EXCEED 500' FEET IN TOTAL LENGTH.

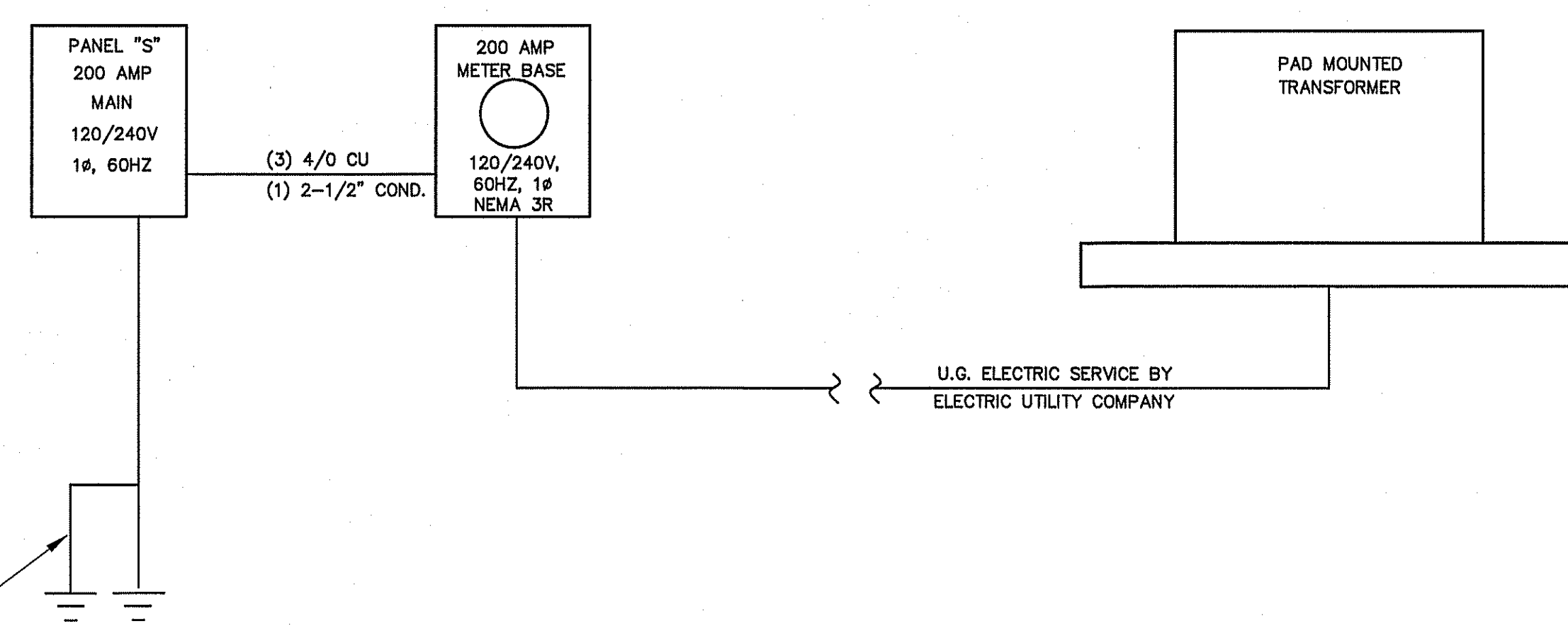

GROUNDING PER NEC 250. #6 CU TO COLD WATER MAIN, BUILDING STEEL, ETC. AS REQUIRED. #6 AWG TO (2) DRIVEN GROUND RODS, MINIMUM OF 6' APART. BOND ALL SERVICE GROUNDING ELECTRODES PER NEC 250 WITH (1) #6 CU GND

ELECTRICAL RISER DIAGRAM
NOT TO SCALE