

SCALE NOTE:  
LARGE FORMAT PRINTS ARE TO SCALE AS NOTED.  
11" x 17" PRINTS ARE ONE HALF THE NOTED SCALE

FOR OPTIONAL BRICK:  
12" FDN. ON 20" WIDE BY 8" DEEP CONT.  
CONC. FTG. (TYP. FOR BRICK VENEER),  
OR FOR "HIGH WIND ZONES" 12" FDN. ON  
24" WIDE BY 8" DEEP CONT. CONC. FTG.  
REINFORCED WITH THREE #4 REBAR (OR  
TWO #5 BARS) AT 3" ABOVE THE BOTTOM  
OF THE FTG. SPLICES MUST BE OVERLAPPED  
25" MIN. (TYP.)

8" FDN. ON 16" WIDE BY 8" DEEP CONT.  
CONC. FTG. (TYP.), OR FOR "HIGH WIND ZONES"  
8" FDN. ON 24" WIDE BY 8" DEEP CONT.  
CONC. FTG. REINFORCED W/ THREE #4  
REBAR (OR TWO #5 BARS) AT 3" ABOVE  
THE BOTTOM OF THE FTG. SPLICES MUST  
BE OVERLAPPED 25" MIN. (TYP.)

120 MPH ULTIMATE DESIGN WIND SPEED  
NOTES FOR LESS THAN  
30' MEAN ROOF HEIGHT:

- ENGINEER'S SEAL APPLIES ONLY TO STRUCTURAL COMPONENTS. ENGINEER'S SEAL DOES NOT CERTIFY DIMENSIONAL ACCURACY OR ARCHITECTURAL LAYOUT INCLUDING ROOF SYSTEM.
- STRUCTURAL DESIGN PER NORTH CAROLINA RESIDENTIAL CODE, 2018 EDITION.
- INSTALL 1/2" ANCHOR BOLTS 6'-0" O.C. AND WITHIN 1'-0" FROM END OF EACH CORNER. ANCHOR BOLTS MUST EXTEND A MINIMUM OF 7" INTO MASONRY OR CONCRETE. LOCATE BOLT WITHIN MIDDLE THIRD OF PLATE WIDTH.
- MEAN ROOF HEIGHT IS LESS THAN 30 FEET.
- EXTERIOR WALLS DESIGNED FOR 120 MPH WINDS.
- WALL CLADDING DESIGNED FOR +15.5 PSF AND -20 PSF (+/- INDICATE POSITIVE / NEGATIVE PRESSURE (TYP.)).
- ROOF CLADDING DESIGNED FOR +14.2 PSF AND -18 PSF FOR ROOF PITCHES 7/12 TO 12/12 AND +10 PSF AND -36 PSF FOR ROOF PITCHED 2.25/12 TO 7/12.
- INSTALL 7/16" OSB SHEATHING ON ALL EXTERIOR WALLS OF ALL STORES IN ACCORDANCE WITH SECTION R602.10.3 OF THE NRCR, 2018 EDITION. SEE THE WALL BRACING NOTES AND DETAILS SHEET FOR MORE INFORMATION.
- ENERGY EFFICIENCY COMPLIANCE AND INSULATION VALUES OF THE BUILDING TO BE IN ACCORDANCE WITH CHAPTER 11 OF THE NRCR, 2018 EDITION.
- REFER TO NOTES AND DETAIL SHEETS FOR ADDITIONAL STRUCTURAL INFORMATION.

150 MPH ULTIMATE DESIGN WIND SPEED  
NOTES FOR LESS THAN  
30' MEAN ROOF HEIGHT:

- ENGINEER'S SEAL APPLIES ONLY TO STRUCTURAL COMPONENTS. ENGINEER'S SEAL DOES NOT CERTIFY DIMENSIONAL ACCURACY OR ARCHITECTURAL LAYOUT INCLUDING ROOF SYSTEM.
- STRUCTURAL DESIGN PER NORTH CAROLINA RESIDENTIAL CODE, 2018 EDITION WITH SPECIAL CONSIDERATION TO CHAPTER 45 (HIGH WIND ZONES) FOR 150 MPH WINDS.
- BUILDER IS TO PROVIDE FRAMING CONNECTIONS AS REQUIRED BY CHAPTER 45 (HIGH WIND ZONES) OF THE NORTH CAROLINA RESIDENTIAL CODE, 2018 EDITION. INSTALL 1/2" ANCHOR BOLTS @ 6'-0" O.C. W/ NUT AND 2" x 2" x 1/8" PLATE WASHER AND WITHIN 1'-0" FROM END OF EACH CORNER WITH MIN. (2) ANCHORS PER PLATE SECTION. ANCHOR BOLTS MUST BE CONTINUOUS FROM THE FOOTING TO A DOUBLE 2 x 6 SILL PLATE. GROUT CELLS CONTAINING ANCHOR BOLTS SOLID.
- ALL EXTERIOR WALLS TO BE SHEATHED WITH 7/16" OSB SHEATHING WITH JOINTS BLOCKED AND SECURED WITH 8d NAILS AT 3" O.C. ALONG PANEL EDGES AND 6" O.C. IN THE FIELD.
- SECURE ALL EXTERIOR WALL SHEATHING PANELS TO DOUBLE TOP PLATES, BANDS, JOISTS, AND GRIDDERS WITH (2) ROWS OF 8d NAILS STAGGERED AT 3" O.C. PANELS SHALL EXTEND 12" BEYOND CONSTRUCTION JOINTS AND SHALL OVERLAP GRIDDERS AND DOUBLE SILL PLATES THEIR FULL DEPTH.
- MEAN ROOF HEIGHT IS LESS THAN 30 FEET.
- WALL CLADDING DESIGNED FOR +24.3 PSF AND -32 PSF (+/- INDICATE POSITIVE / NEGATIVE PRESSURE (TYP.)).
- ROOF CLADDING DESIGNED FOR +22.2 PSF AND -28 PSF FOR ROOF PITCHES 7/12 TO 12/12 AND +14 PSF AND -57 PSF FOR ROOF PITCHED 2.25/12 TO 7/12.
- ENERGY EFFICIENCY COMPLIANCE AND INSULATION VALUES OF THE BUILDING TO BE IN ACCORDANCE WITH CHAPTER 11 OF THE NRCR, 2018 EDITION.

STRUCTURAL NOTES:

- ALL FRAMING LUMBER TO BE #2 SPF (UNO), ALL TREATED LUMBER TO BE #2 SYP (UNO).
- PROVIDE A DOUBLE OR TRIPLE JOIST UNDER ALL WALLS PARALLEL TO FLOOR JOISTS WHERE NOTED ON THE PLANS.
- SQUARES DENOTE POINT LOADS WHICH REQUIRE SOLID BLOCKING TO GIRDER OR FOUNDATION.
- SHADED PIERS TO BE FILLED SOLID.
- INSTALL LADDER WIRE @ 16" O.C. TO SECURE MULTIPLE WYTHE FOUNDATION WALLS TOGETHER.
- REFER TO NOTES AND DETAIL SHEETS FOR ADDITIONAL STRUCTURAL INFORMATION.

LEGEND

CONT	CONTINUOUS
XJ	EXTRA JOIST
DJ	DOUBLE JOIST
TJ	TRIPLE JOIST
EA	EACH
FDN	FOUNDATION
FTG	FOOTING
OC	ON CENTER
SPF	SPRUCE PINE FIR
SYP	SOUTHERN YELLOW PINE
TRD	PRESSURE TREATED
TYP	TYPICAL
UNO	UNLESS NOTED OTHERWISE

J.S. THOMPSON  
ENGINEERING, INC  
333 EAST SIX FORKS ROAD, SUITE 180 RALEIGH, NC 27609  
PHONE: (919) 789-9919 FAX: (919) 789-9921  
N.C. LICENSE NO.: C-17133

McCLEAN II - N.C.  
GREAT SOUTHERN HOMES

DATE: OCTOBER 24, 2023

SCALE: 1/4" = 1'-0"

DRAWN BY: GREAT SOUTHERN HOMES

ENGINEERED BY: WFB

S-1a  
CRAWL  
FOUNDATION PLAN

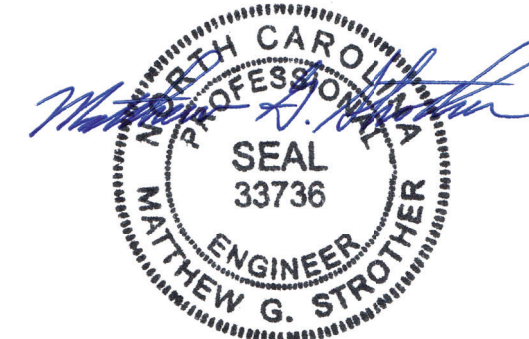

10/25/2023

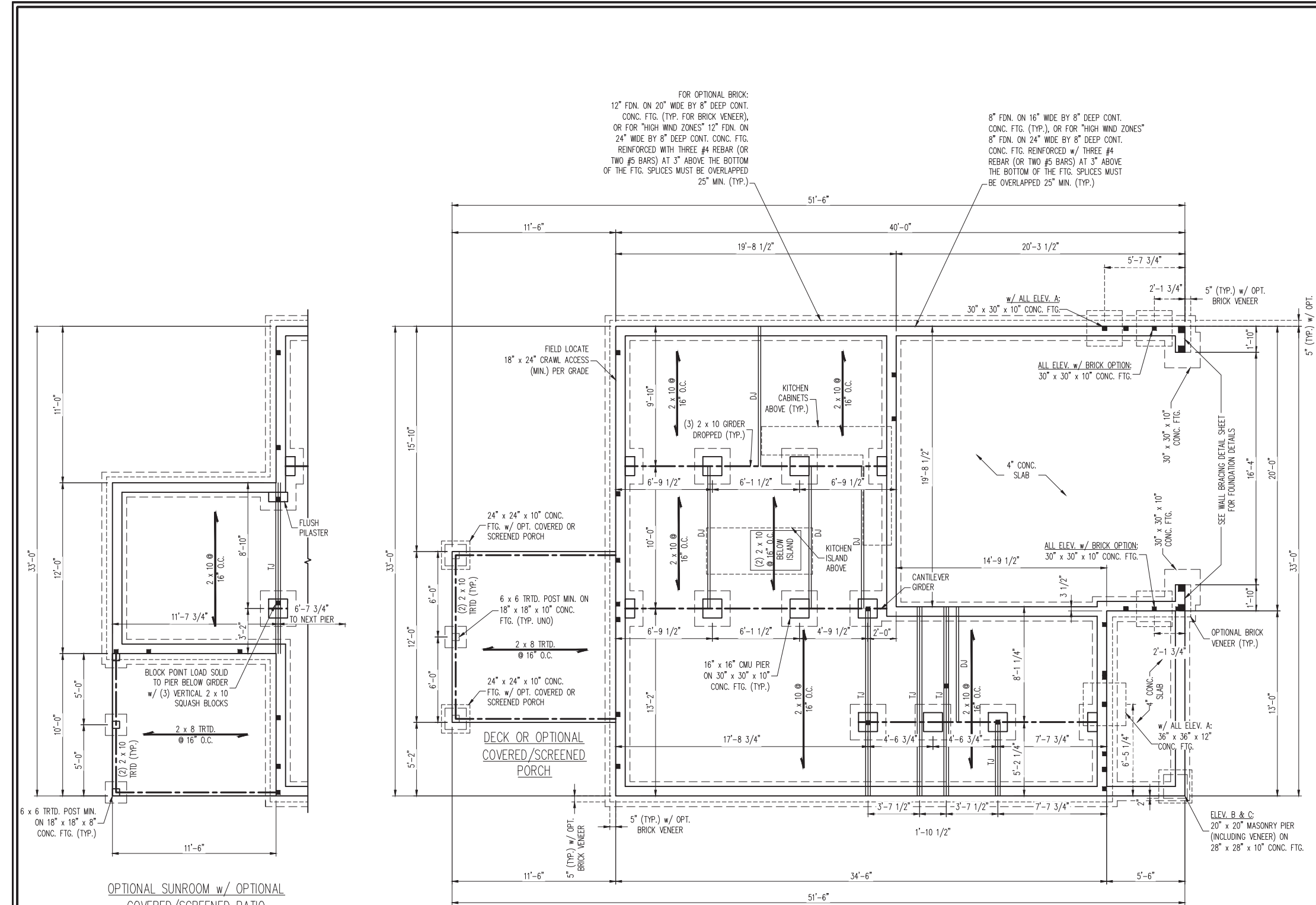

ALL ELEVATIONS



SCALE NOTE:  
LARGE FORMAT PRINTS ARE TO SCALE AS NOTED.  
11" x 17" PRINTS ARE ONE HALF THE NOTED SCALE

150 MPH ULTIMATE DESIGN WIND SPEED  
STRUCTURAL NOTES

- ALL CONSTRUCTION TO BE IN ACCORDANCE WITH CHAPTER 45 OF THE 2018 NRC.
- ALL FRAMING LUMBER TO BE SPF #2 (UNO). ALL TREATED LUMBER TO BE SYP #2 (UNO).
- ALL LOAD BEARING HEADERS TO BE (2) 2 x 6 (UNO).
- INSTALL 2 x 4 @ 16" O.C. BLOCKING BETWEEN ADJACENT TRUSSES UNDER WALLS PARALLEL TO FLOOR TRUSSES WHERE WALL LENGTH EXCEEDS 1/3 OF TRUSS SPAN (SEE DETAIL THIS SHEET). TRUSS DESIGNER TO DESIGN ADJACENT TRUSSES FOR ADDITIONAL LOADING FROM WALLS.
- EXTERIOR WINDOW AND DOOR HEADERS TO BE SUPPORTED w/ (1) JACK STUD AND (2) KING STUDS EA. END (UNO.). SEE TABLE THIS SHEET FOR ADDITIONAL KING STUD REQUIREMENTS.
- SQUARES DENOTE POINT LOADS WHICH REQUIRE SOLID BLOCKING TO GIRDER OR FOUNDATION. ALL SQUARES TO BE (2) STUDS (UNO.).
- ALL 4 x 4 POSTS SHALL BE ANCHORED TO SLABS w/ SIMPSON ABU44 POST BASES (OR EQUAL) AND 6 x 6 POSTS w/ ABU66 POST BASES (OR EQUAL) (UNO). ALL 4 x 4 AND 6 x 6 POSTS TO BE INSTALLED WITH 1000 LB CAPACITY UPLIFT CONNECTORS AT TOP (UNO).
- FOR FIBERGLASS, ALUMINUM, OR COLUMN ENG. BY OTHERS, SECURE TO SLAB w/ (2) METAL ANGLES USING 2" CONC. SCREWS. FASTEN ANGLES TO COLUMNS w/ 1/4" THROUGH BOLTS w/ NUTS AND WASHERS. LOCATE ANGLES ON OPPOSITE SIDES OF COLUMN. THROUGH BOLTS MUST BE INSTALLED PRIOR TO SETTING COLUMN.
- ALL EXTERIOR WALLS TO BE SHEATHED WITH 7/16" OSB SHEATHING WITH JOINTS BLOCKED AND SECURED WITH 8d NAILS AT 3" O.C. ALONG PANEL EDGES AND 6" O.C. IN THE FIELD.
- SECURE ALL EXTERIOR WALL SHEATHING PANELS TO DOUBLE TOP PLATES, BANDS, JOISTS, AND GIRDERS WITH (2) ROWS OF 8d NAILS STAGGERED AT 3" O.C. PANELS SHALL EXTEND 12" BEYOND CONSTRUCTION JOINTS AND SHALL OVERLAP GIRDERS AND DOUBLE SILL PLATES THEIR FULL DEPTH.
- REFER TO NOTES AND DETAIL SHEETS FOR ADDITIONAL STRUCTURAL INFORMATION.

HEADER SPAN (FEET)	MINIMUM NUMBER OF FULL HEIGHT STUDS (KINGS)
UP TO 3'	2
> 3' TO 6'	3
> 6' TO 9'	4
> 9' TO 12'	5
> 12' TO 15'	6

TABLE R602.7.5  
MINIMUM NUMBER OF FULL HEIGHT KING STUDS AT EACH END OF HEADERS IN EXTERIOR WALLS IN 120 MPH WIND ZONES

HEADER SPAN (FEET)	MINIMUM NUMBER OF FULL HEIGHT STUDS (KINGS)
UP TO 3'	1
> 3' TO 6'	2
> 6' TO 9'	3
> 9' TO 12'	4
> 12' TO 15'	5

120 MPH ULTIMATE DESIGN WIND SPEED  
STRUCTURAL NOTES:

- ALL FRAMING LUMBER TO BE SPF #2 (UNO). ALL TREATED LUMBER TO BE SYP #2 (UNO).
- ALL LOAD BEARING HEADERS TO BE (2) 2 x 6 (UNO).
- INSTALL 2 x 4 @ 16" O.C. BLOCKING BETWEEN ADJACENT TRUSSES UNDER WALLS PARALLEL TO FLOOR TRUSSES WHERE WALL LENGTH EXCEEDS 1/3 OF TRUSS SPAN (SEE DETAIL THIS SHEET). TRUSS DESIGNER TO DESIGN ADJACENT TRUSSES FOR ADDITIONAL LOADING FROM WALLS.
- WINDOW AND DOOR HEADERS TO BE SUPPORTED w/ (1) JACK STUD AND (1) KING STUD EA. END (UNO.). SEE TABLE R602.7.5 FOR ADDITIONAL KING STUD REQUIREMENTS.
- SQUARES DENOTE POINT LOADS WHICH REQUIRE SOLID BLOCKING TO GIRDER OR FOUNDATION. ALL SQUARES TO BE (2) STUDS (UNO.).
- ALL 4 x 4 POSTS SHALL BE ANCHORED TO SLABS w/ SIMPSON ABU44 POST BASES (OR EQUAL) AND 6 x 6 POSTS w/ ABU66 POST BASES (OR EQUAL) (UNO). ALL 4 x 4 AND 6 x 6 POSTS TO BE INSTALLED WITH 700 LB CAPACITY UPLIFT CONNECTORS AT TOP (UNO).
- FOR FIBERGLASS, ALUMINUM, OR COLUMN ENG. BY OTHERS, SECURE TO SLAB w/ (2) METAL ANGLES USING 2" CONC. SCREWS. FASTEN ANGLES TO COLUMNS w/ 1/4" THROUGH BOLTS w/ NUTS AND WASHERS. LOCATE ANGLES ON OPPOSITE SIDES OF COLUMN. THROUGH BOLTS MUST BE INSTALLED PRIOR TO SETTING COLUMN.
- REFER TO NOTES AND DETAIL SHEETS FOR ADDITIONAL STRUCTURAL INFORMATION.

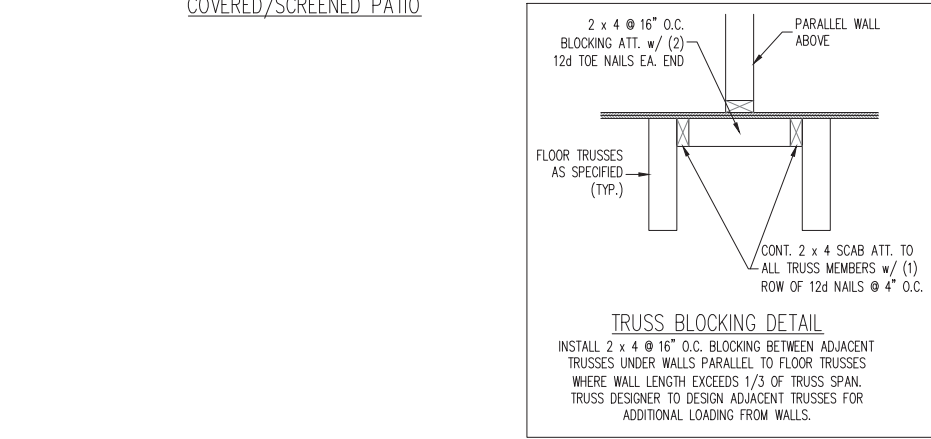
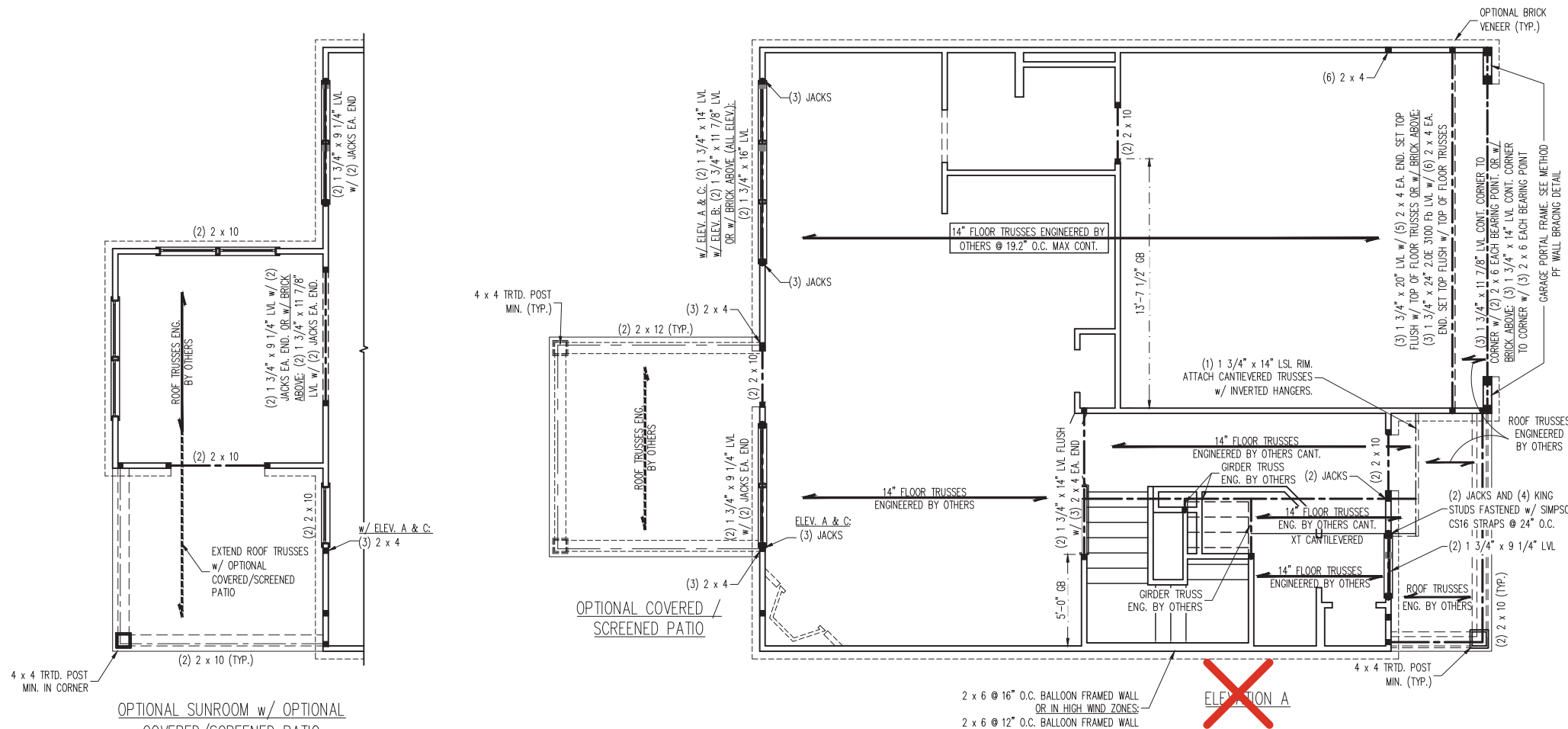

**BRACED WALL DESIGN NOTES:**

- BRACED WALL DESIGN PER SECTION R602.10.5 "WALL BRACING BY ENGINEERED DESIGN" OF THE NRC 2018 EDITION USING BRACING MATERIALS AND METHODS LISTED IN TABLE R602.10.1 ALONG WITH ALTERNATIVE MATERIALS AND METHODS THAT COMPLY WITH ACCEPTED ENGINEERING PRACTICE. BRACED WALL DESIGN IS NOT PRESCRIPTIVE.
- SHEATH ALL EXTERIOR WALLS w/ 7/16" OSB TO PROVIDE CS-WSP WALL BRACING THAT WILL BRACE THE STRUCTURE FOR ALL LATERAL LOADS AS REQUIRED BY THE NRC 2018 EDITION.
- CS-WSP REFERS TO "CONTINUOUSLY SHEATHED WOOD STRUCTURAL PANELS." CONTRACTOR IS TO INSTALL 7/16" OSB ON ALL EXTERIOR WALLS ATTACHED w/ 8d NAILS SPACED 6" O.C. ALONG PANEL EDGES AND 12" O.C. IN THE FIELD.
- GB REFERS TO "GYPSUM BOARD." CONTRACTOR IS TO INSTALL 1/2" (MIN.) GYPSUM BOARD ON BOTH SIDES OF WALL WHERE NOTED ON THE PLANS ATTACHED WITH 1 1/4" LONG #6 SCREWS OR 1 5/8" LONG 5d COOLER NAILS SPACED 7" O.C. ALONG PANEL EDGES AND IN THE FIELD.
- BRACED WALL DESIGN APPLIED IN WIND ZONES UP TO 130 MPH. FOR HIGH WIND ZONES, BRACED WALLS ARE TO BE CONSTRUCTED IN ACCORDANCE WITH CHAPTER 45 OF THE NRC 2018 EDITION.
- SEE NOTES AND DETAIL SHEETS FOR ADDITIONAL BRACED WALL INFORMATION.

LINTEL SCHEDULE FOR BRICK/NATURAL STONE SUPPORT

LENGTH (FT.)	SIZE OF LINTEL
UP TO 4 FT.	L 3 1/2 x 3 1/2 x 1/4
4-8	L 5 x 3 1/2 x 5/16 LLV
8 AND GREATER	L 6 x 4 x 5/16 LLV

**BRICK SUPPORT NOTES:**

- LINTEL SCHEDULE APPLIES TO ALL OPENINGS IN BRICK VENEER (UNO). SEE ARCH DWGS. FOR SIZE AND LOCATION OF OPENINGS.
- (LLV) = LONG LEG VERTICAL
- LENGTH = CLEAR OPENING
- EMBED ALL ANGLE IRONS MIN. 4" EACH SIDE INTO VENEER TO PROVIDE BEARING.
- FOR ALL HEADERS 8'-0" AND GREATER IN LENGTH, ATTACH STEEL ANGLE TO HEADER w/ 1/2" LAG SCREWS @ 12" O.C. STAGGERED.
- FOR ALL BRICK SUPPORT @ ROOF LINES, FASTEN (2) 2 x 10 BLOCKING BETWEEN STUDS w/ (4) 12d NAILS PER PLY. FASTEN A 6" x 4" x 5/16" STEEL ANGLE TO (2) 2 x 10 BLOCKING w/ (2) 1/2" LAG SCREWS @ 12" O.C. STAGGERED. SEE SECTION R703.8.2.1 OF THE 2018 NRC FOR ADDITIONAL BRICK SUPPORT INFORMATION.
- PRECAST REINFORCED CONCRETE LINTELS ENGINEERED BY OTHERS MAY BE USED IN LIEU OF STEEL LINTELS.

LEGEND

CONT	CONTINUOUS
XT	EXTRA TRUSS
EA	EACH
( )	NUMBER OF STUDS
DSP	DOUBLE STUD POCKET
TSP	TRIPLE STUD POCKET
OC	ON CENTER
SPF	SPRUCE PINE FIR
SYP	SOUTHERN YELLOW PINE
TRTD	PRESSURE TREATED
TYP	TYPICAL
UNO	UNLESS NOTED OTHERWISE

**J.S. THOMPSON ENGINEERING, INC**  
333 EAST SIX FORKS ROAD, SUITE 180 RALEIGH, NC 27609  
PHONE: (919) 789-9919 FAX: (919) 789-9921  
N.C. LICENSE NO.: C-1733

McCLEAN II - N.C.  
GREAT SOUTHERN HOMES

DATE: OCTOBER 24, 2023  
SCALE: 1/4" = 1'-0"  
DRAWN BY: GREAT SOUTHERN HOMES  
ENGINEERED BY: WFB

S-2a  
SECOND FLOOR FRAMING PLAN

SCALE NOTE:  
 LARGE FORMAT PRINTS ARE TO SCALE AS NOTED.  
 11" x 17" PRINTS ARE ONE HALF THE NOTED SCALE

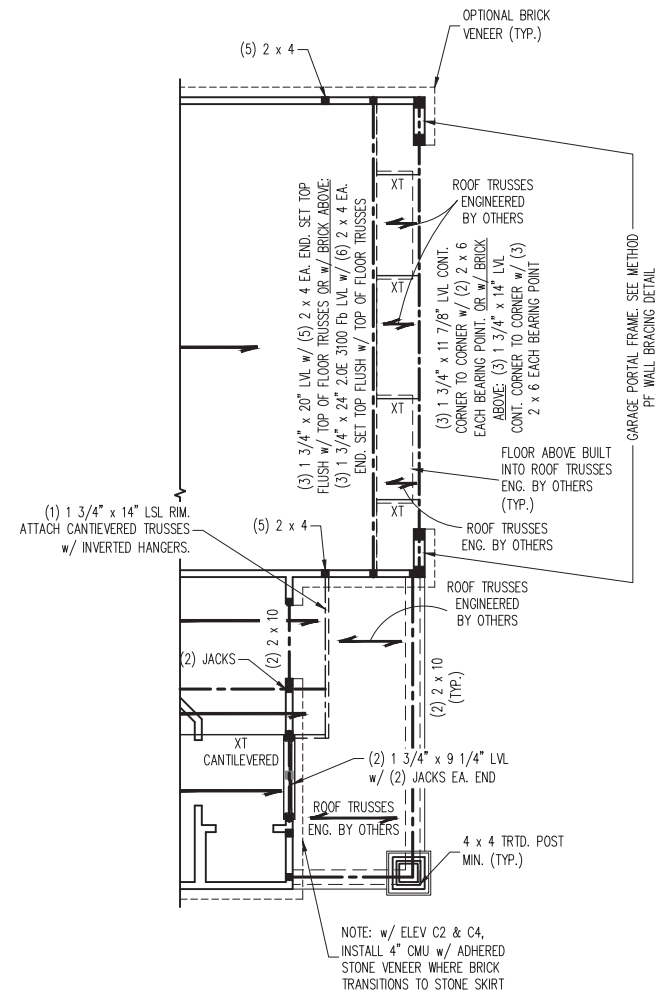

~~ELEVATION C~~

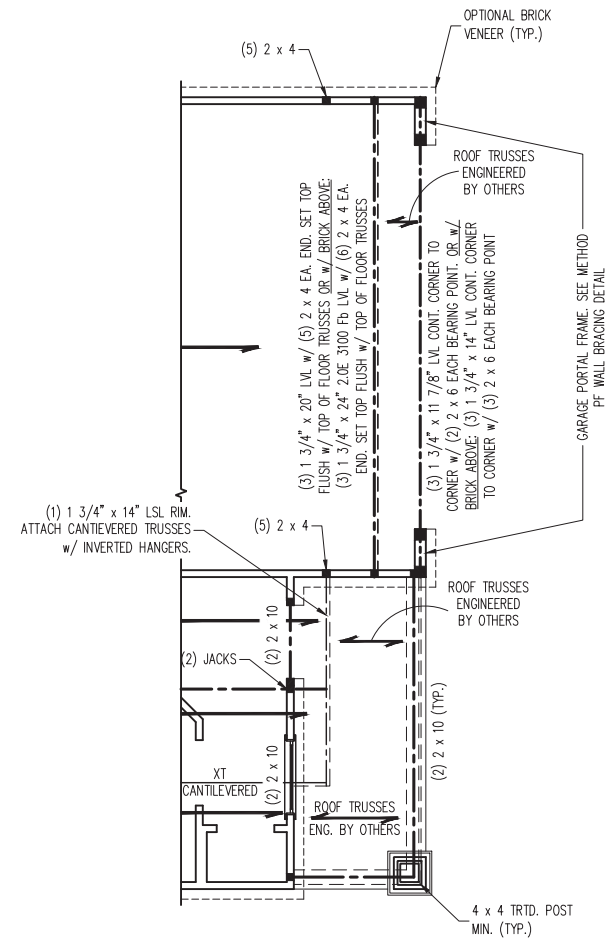

ELEVATION B



10/25/2023

**J.S. THOMPSON ENGINEERING, INC**  
 333 EAST SIX FORKS ROAD, SUITE 180 RALEIGH, NC 27609  
 PHONE: (919) 789-9919 FAX: (919) 789-9921  
 N.C. LICENSE NO.: C-1733

McCLEAN II - N.C.  
 GREAT SOUTHERN HOMES

DATE: OCTOBER 24, 2023  
 SCALE: 1/4" = 1'-0"  
 DRAWN BY: GREAT SOUTHERN HOMES  
 ENGINEERED BY: WFB

S-2b  
 SECOND FLOOR  
 FRAMING PLAN

SCALE NOTE:  
LARGE FORMAT PRINTS ARE TO SCALE AS NOTED.  
11" x 17" PRINTS ARE ONE HALF THE NOTED SCALE

**BRACED WALL DESIGN NOTES:**

- BRACED WALL DESIGN PER SECTION R602.10.5 "WALL BRACING BY ENGINEERED DESIGN" OF THE NRC 2018 EDITION USING BRACING MATERIALS AND METHODS LISTED IN TABLE R602.10.1 ALONG WITH ALTERNATIVE MATERIALS AND METHODS THAT COMPLY WITH ACCEPTED ENGINEERING PRACTICE. BRACED WALL DESIGN IS NOT PRESCRIPTIVE.
- SHEATH ALL EXTERIOR WALLS w/ 7/16" OSB TO PROVIDE CS-WSP WALL BRACING THAT WILL BRACE THE STRUCTURE FOR ALL LATERAL LOADS AS REQUIRED BY THE NRC 2018 EDITION.
- CS-WSP REFERS TO "CONTINUOUSLY SHEATHED WOOD STRUCTURAL PANELS." CONTRACTOR IS TO INSTALL 7/16" OSB ON ALL EXTERIOR WALLS ATTACHED w/ 8d NAILS SPACED 6" O.C. ALONG PANEL EDGES AND 12" O.C. IN THE FIELD.
- GB REFERS TO "GYPSUM BOARD." CONTRACTOR IS TO INSTALL 1/2" (MIN.) GYPSUM BOARD ON BOTH SIDES OF WALL WHERE NOTED ON THE PLANS ATTACHED WITH 1 1/4" LONG #6 SCREWS OR 1 5/8" LONG 5d COOLER NAILS SPACED 7" O.C. ALONG PANEL EDGES AND IN THE FIELD.
- BRACED WALL DESIGN APPLIED IN WIND ZONES UP TO 130 MPH. FOR HIGH WIND ZONES, BRACED WALLS ARE TO BE CONSTRUCTED IN ACCORDANCE WITH CHAPTER 45 OF THE NRC 2018 EDITION.
- SEE NOTES AND DETAIL SHEETS FOR ADDITIONAL BRACED WALL INFORMATION.

**J.S. THOMPSON  
ENGINEERING, INC**  
333 EAST SIX FORKS ROAD, SUITE 180 RALEIGH, NC 27609  
PHONE: (919) 789-9919 FAX: (919) 789-9921  
N.C. LICENSE NO.: C1713

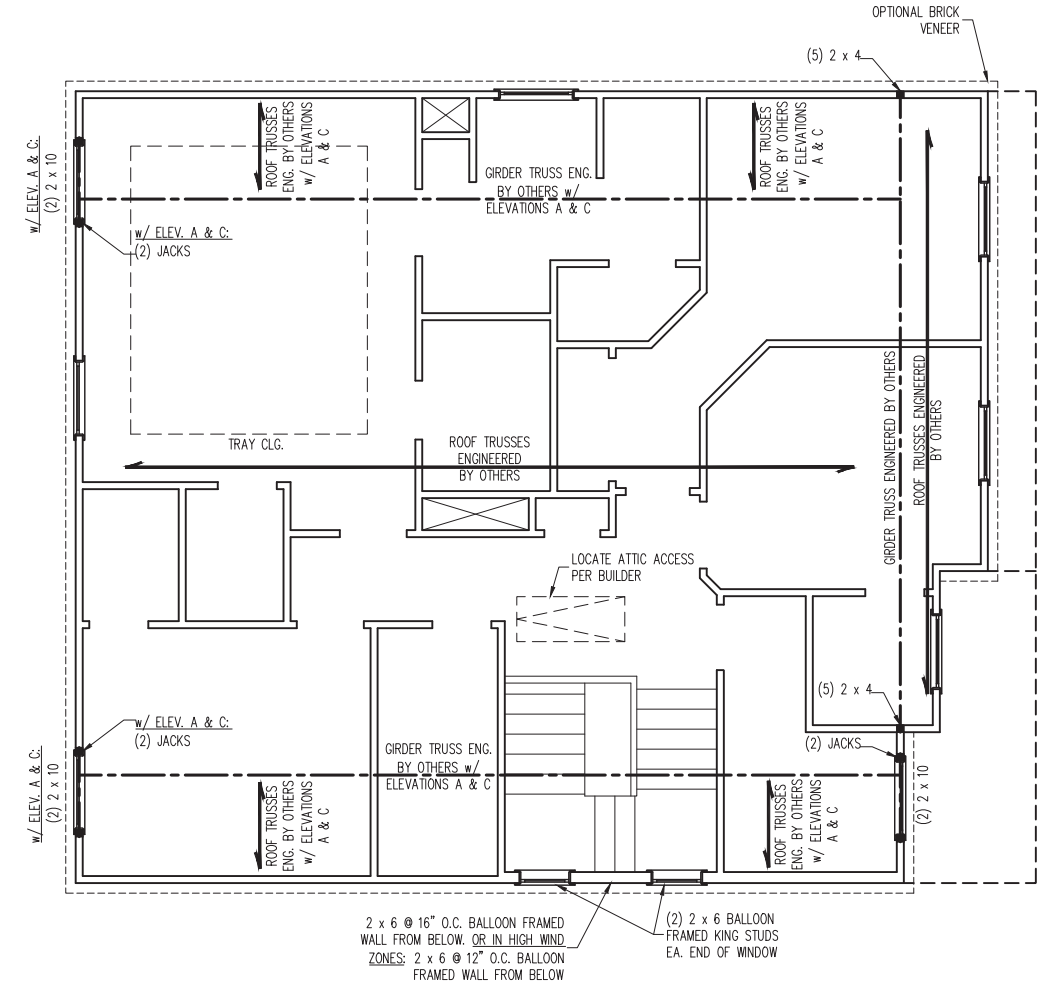

MINIMUM NUMBER OF FULL HEIGHT KING STUDS AT EACH END OF HEADERS IN EXTERIOR WALLS IN 150 MPH WIND ZONES

HEADER SPAN (FEET)	MINIMUM NUMBER OF FULL HEIGHT STUDS (KINGS)
UP TO 3'	2
> 3' TO 6'	3
> 6' TO 9'	4
> 9' TO 12'	5
> 12' TO 15'	6

- 150 MPH ULTIMATE DESIGN WIND SPEED STRUCTURAL NOTES:**
- ALL CONSTRUCTION TO BE IN ACCORDANCE WITH CHAPTER 45 OF THE 2018 NRC.
  - ALL FRAMING LUMBER TO BE SPF #2 (UNO). ALL TREATED LUMBER TO BE SYP #2 (UNO).
  - ALL LOAD BEARING HEADERS TO BE (2) 2 x 6 (UNO).
  - EXTERIOR WINDOW AND DOOR HEADERS TO BE SUPPORTED w/ (1) JACK STUD AND (2) KING STUDS EA. END (UNO.). SEE TABLE THIS SHEET FOR ADDITIONAL KING STUD REQUIREMENTS.
  - SQUARES DENOTE POINT LOADS WHICH REQUIRE SOLID BLOCKING TO GIRDER OR FOUNDATION. ALL SQUARES TO BE (2) STUDS (UNO.).
  - ALL EXTERIOR WALLS TO BE SHEATHED WITH 7/16" OSB SHEATHING WITH JOINTS BLOCKED AND SECURED WITH 8d NAILS AT 3" O.C. ALONG PANEL EDGES AND 6" O.C. IN THE FIELD.
  - SECURE ALL EXTERIOR WALL SHEATHING PANELS TO DOUBLE TOP PLATES, BANDS, JOISTS, AND GIRDERS WITH (2) ROWS OF 8d NAILS STAGGERED AT 3" O.C. PANELS SHALL EXTEND 12" BEYOND CONSTRUCTION JOINTS AND SHALL OVERLAP GIRDERS AND DOUBLE SILL PLATES THEIR FULL DEPTH.
  - REFER TO NOTES AND DETAIL SHEETS FOR ADDITIONAL STRUCTURAL INFORMATION.

TABLE R602.7.5  
MINIMUM NUMBER OF FULL HEIGHT KING STUDS AT EACH END OF HEADERS IN EXTERIOR WALLS IN 120 MPH WIND ZONES

HEADER SPAN (FEET)	MINIMUM NUMBER OF FULL HEIGHT STUDS (KINGS)
UP TO 3'	1
> 3' TO 6'	2
> 6' TO 9'	3
> 9' TO 12'	4
> 12' TO 15'	5

- 120 MPH ULTIMATE DESIGN WIND SPEED STRUCTURAL NOTES:**
- ALL FRAMING LUMBER TO BE #2 SPF (UNO).
  - ALL LOAD BEARING HEADERS TO BE (2) 2 x 6 (UNO).
  - WINDOW AND DOOR HEADERS TO BE SUPPORTED w/ (1) JACK STUD AND (1) KING STUD EA. END (UNO.). SEE TABLE R602.7.5 FOR ADDITIONAL KING STUD REQUIREMENTS.
  - SQUARES DENOTE POINT LOADS WHICH REQUIRE SOLID BLOCKING TO GIRDER OR FOUNDATION. SQUARES TO BE (2) STUDS (UNO.).
  - REFER TO NOTES AND DETAIL SHEETS FOR ADDITIONAL STRUCTURAL INFORMATION.

**LINTEL SCHEDULE FOR BRICK/NATURAL STONE SUPPORT**

LENGTH (FT.)	SIZE OF LINTEL
UP TO 4 FT.	L 3 1/2 x 3 1/2 x 1/4
4-8	L 5 x 3 1/2 x 5/16 LLV
8 AND GREATER	L 6 x 4 x 5/16 LLV

- BRICK SUPPORT NOTES:**
- LINTEL SCHEDULE APPLIES TO ALL OPENINGS IN BRICK VENEER (UNO). SEE ARCH DWGS. FOR SIZE AND LOCATION OF OPENINGS.
  - (LLV) = LONG LEG VERTICAL
  - LENGTH = CLEAR OPENING
  - EMBED ALL ANGLE IRONS MIN. 4" EACH SIDE INTO VENEER TO PROVIDE BEARING.
  - FOR ALL HEADERS 8'-0" AND GREATER IN LENGTH, ATTACH STEEL ANGLE TO HEADER w/ 1/2" LAG SCREWS @ 12" O.C. STAGGERED.
  - FOR ALL BRICK SUPPORT @ ROOF LINES, FASTEN (2) 2 x 10 BLOCKING BETWEEN STUDS w/ (4) 12d NAILS PER PLY. FASTEN A 6" x 4" x 5/16" STEEL ANGLE TO (2) 2 x 10 BLOCKING w/ (2) 1/2" LAG SCREWS @ 12" O.C. STAGGERED. SEE SECTION R703.8.2.1 OF THE 2018 NRC FOR ADDITIONAL BRICK SUPPORT INFORMATION.
  - PRECAST REINFORCED CONCRETE LINTELS ENGINEERED BY OTHERS MAY BE USED IN LIEU OF STEEL LINTELS.



10/25/2023

**LEGEND**

CONT	CONTINUOUS
XT	EXTRA TRUSS
TS	TRUSS SUPPORT
EA	EACH
( )	NUMBER OF STUDS
DSP	DOUBLE STUD POCKET
TSP	TRIPLE STUD POCKET
OC	ON CENTER
SPF	SPRUCE PINE FIR
SYP	SOUTHERN YELLOW PINE
TRTD	PRESSURE TREATED
TYP	TYPICAL
UNO	UNLESS NOTED OTHERWISE

DATE: OCTOBER 24, 2023  
SCALE: 1/4" = 1'-0"  
DRAWN BY: GREAT SOUTHERN HOMES  
ENGINEERED BY: WFB

S-3a  
ATTIC FLOOR  
FRAMING PLAN

McCLEAN II - N.C.  
GREAT SOUTHERN HOMES

SCALE NOTE:  
LARGE FORMAT PRINTS ARE TO SCALE AS NOTED.  
11" x 17" PRINTS ARE ONE HALF THE NOTED SCALE

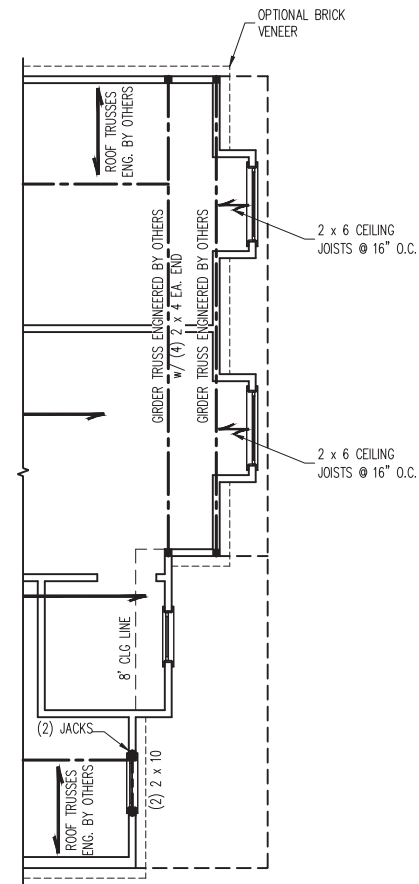

~~ELEVATION A~~

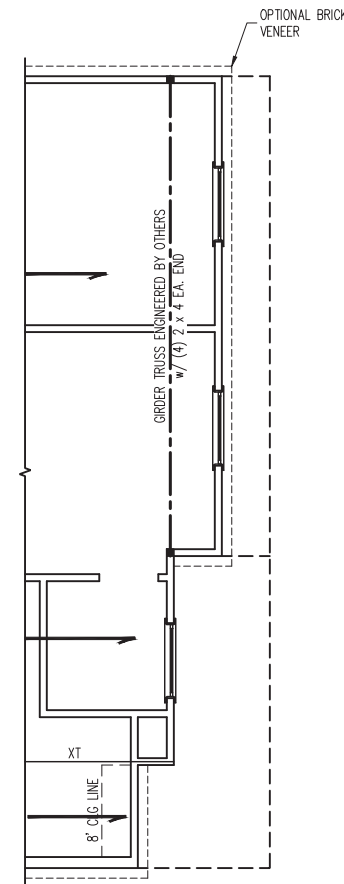

ELEVATION B



10/25/2023

**J.S. THOMPSON  
ENGINEERING, INC**  
333 EAST SIX FORKS ROAD, SUITE 180 RALEIGH, NC 27609  
PHONE: (919) 789-9919 FAX: (919) 789-9921  
N.C. LICENSE NO.: C-1733

McCLEAN II - N.C.  
GREAT SOUTHERN HOMES

DATE: OCTOBER 24, 2023  
SCALE: 1/4" = 1'-0"  
DRAWN BY: GREAT SOUTHERN HOMES  
ENGINEERED BY: WFB

S-3a  
ATTIC FLOOR  
FRAMING PLAN

SCALE NOTE:  
 LARGE FORMAT PRINTS ARE TO SCALE AS NOTED.  
 11" x 17" PRINTS ARE ONE HALF THE NOTED SCALE

- BRICK SUPPORT NOTE:**
1. FASTEN (2) 2 x 10 BLOCKING BETWEEN WALL STUDS w/ (4) 12d NAILS PER PLY. FASTEN A 6" x 4" x 5/16" STEEL ANGLE TO (2) 2 x 10 BLOCKING w/ (2) 1/2" LAG SCREWS @ 12" O.C. STAGGERED. SEE SECTION R703.8.2.1 OF THE 2018 NRC FOR ADDITIONAL BRICK SUPPORT INFORMATION.
  2. WHERE ROOF SLOPES EXCEED 7:12, INSTALL 3" x 3" x 1/4" STEEL PLATE STOPS AT 24" O.C. PER SECTION R703.8.2.1 OF THE NORTH CAROLINA RESIDENTIAL CODE, 2018 EDITION.

**J.S. THOMPSON  
 ENGINEERING, INC**  
 333 EAST SIX FORKS ROAD, SUITE 180 RALEIGH, NC 27609  
 PHONE: (919) 789-9919 FAX: (919) 789-9921  
 N.C. LICENSE NO.: C1733

- 150 MPH ULTIMATE DESIGN WIND SPEED  
 ROOF STRUCTURAL NOTES:**
1. ALL CONSTRUCTION TO BE IN ACCORDANCE WITH CHAPTER 45 OF THE 2018 NRC.
  2. ALL FRAMING LUMBER TO BE #2 SPF (UNO).
  3. SECURE EA. RAFTER OR TRUSS TO BEARING WALL w/ (2) SIMPSON H2.5A OR (1) SIMPSON H10A HURRICANE TIE (OR EQUAL) UNLESS NOTED OTHERWISE BY TRUSS ENGINEER BASED ON DESIGN UPLIFT FOR EA. TRUSS.
  4. ROOF SHEATHING PANELS TO BE 7/16" MINIMUM THICKNESS. SECURE PANELS TO RAFTERS OR TRUSSES w/ 10d NAILS AT 6" O.C. ALONG EDGES AND 12" O.C. IN THE FIELD. ATTACH SHEATHING TO GABLE FRAMING AT 4" O.C..
  5. INSTALL 2x BLOCKING AT SHEATHING JOINTS, INCLUDING RIDGES, IN THE END TWO RAFTER OR TRUSS SPACES.
  6. STICK FRAME OVER-FRAMED ROOF SECTIONS w/ 2 x 8 RIDGES, 2 x 6 RAFTERS @ 16" O.C. AND FLAT 2 x 10 VALLEYS OR USE VALLEY TRUSSES.
  7. FASTEN FLAT VALLEYS TO RAFTERS OR TRUSSES WITH SIMPSON H2.5A HURRICANE TIES @ 32" O.C. MAX. PASS HURRICANE TIES THROUGH NOTCH IN ROOF SHEATHING. EACH RAFTER IS TO BE FASTENED TO THE FLAT VALLEY WITH A MIN. OF (6) 12d TOE NAILS.
  8. REFER TO NOTES AND DETAIL SHEETS FOR ADDITIONAL STRUCTURAL INFORMATION.

- 120 MPH ULTIMATE DESIGN WIND SPEED  
 ROOF STRUCTURAL NOTES:**
1. ALL FRAMING LUMBER TO BE #2 SPF (UNO).
  2. STICK FRAME OVER-FRAMED ROOF SECTIONS w/ 2 x 8 RIDGES, 2 x 6 RAFTERS @ 16" O.C. AND FLAT 2 x 10 VALLEYS.
  3. FASTEN FLAT VALLEYS TO RAFTERS WITH SIMPSON H2.5A HURRICANE TIES @ 32" O.C. MAX. PASS HURRICANE TIES THROUGH NOTCH IN ROOF SHEATHING. EACH RAFTER IS TO BE FASTENED TO THE FLAT VALLEY WITH A MIN. OF (6) 12d TOE NAILS.
  4. REFER TO SECTION R802.11 OF THE 2018 NRC FOR REQUIRED UPLIFT RESISTANCE AT RAFTERS.
  5. REFER TO NOTES AND DETAIL SHEETS FOR ADDITIONAL STRUCTURAL INFORMATION.

NOTE: REFER TO ARCHITECTURAL DRAWINGS FOR ROOF PITCHES, PLATE HEIGHTS, DIMENSIONS, OVERHANG WIDTHS, AND ATTIC VENT CALCS.

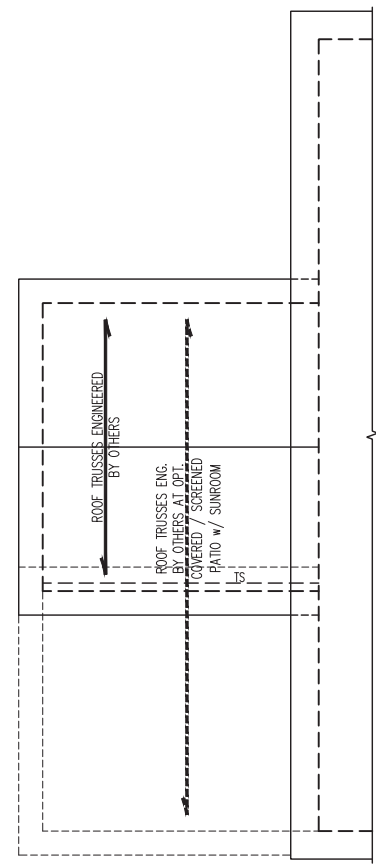
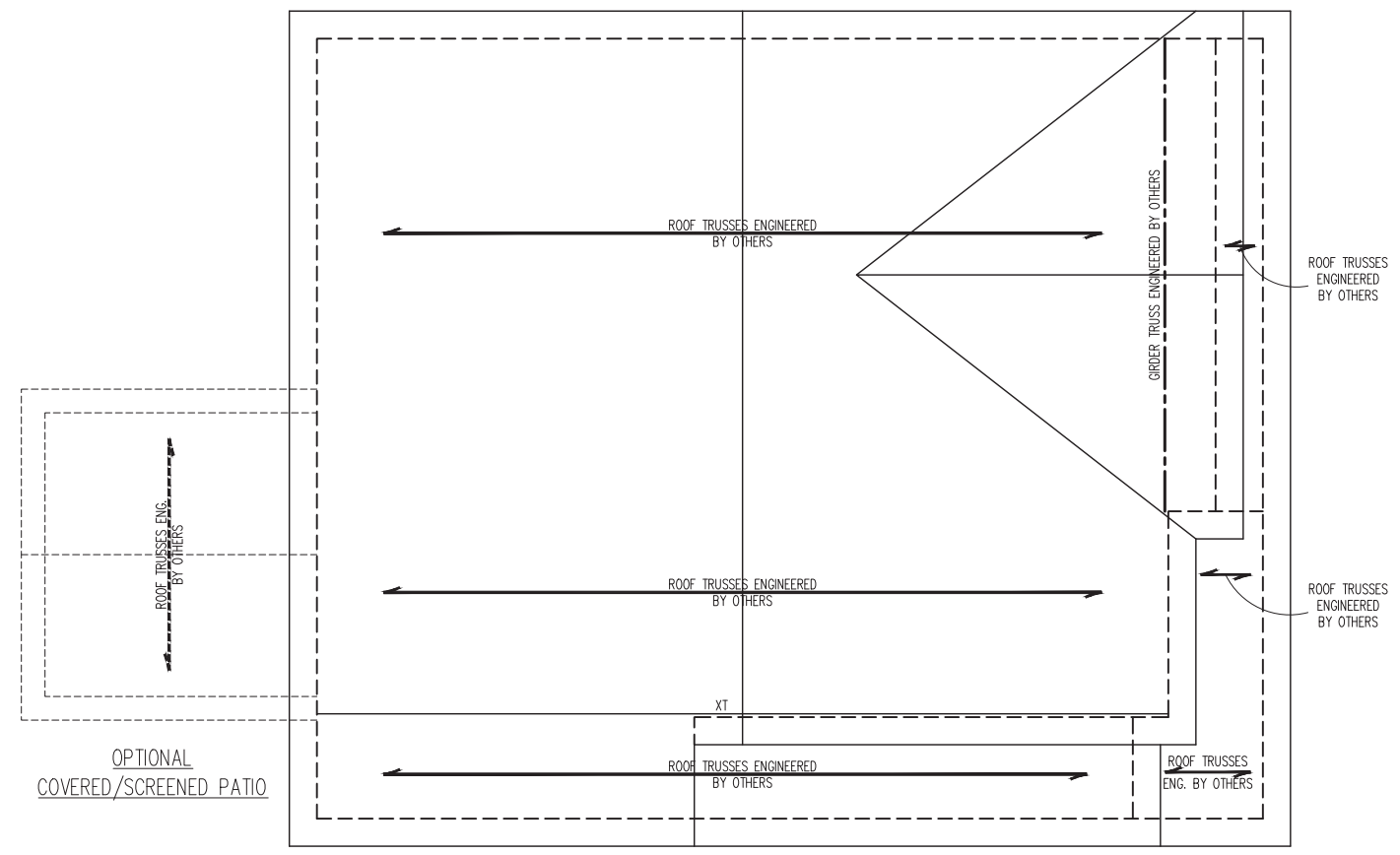

OPTIONAL SUNROOM w/ OPT. COVERED/SCREENED PATIO

ELEVATION B



10/25/2023

**LEGEND**

XT	EXTRA TRUSS
TS	TRUSS SUPPORT
XR	EXTRA RAFTER
RS	RAFTER SUPPORT
CONT	CONTINUOUS
EA	EACH
OC	ON CENTER
SPF	SPRUCE PINE FIR
SYP	SOUTHERN YELLOW PINE
TYP	TYPICAL
UNO	UNLESS NOTED OTHERWISE

DATE: OCTOBER 24, 2023  
 SCALE: 1/4" = 1'-0"  
 DRAWN BY: GREAT SOUTHERN HOMES  
 ENGINEERED BY: WFB

McCLEAN II - N.C.  
 GREAT SOUTHERN HOMES

S-4b  
 ROOF FRAMING PLAN

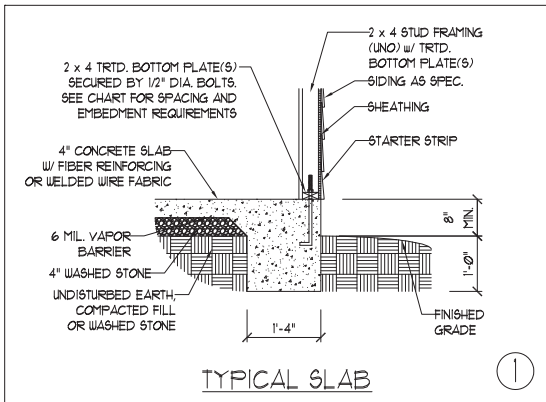

TYPICAL SLAB ①

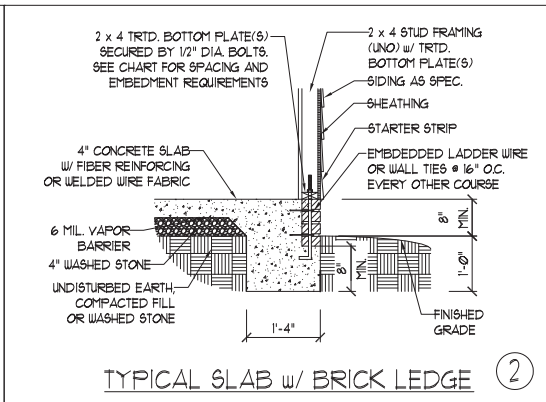

TYPICAL SLAB w/ BRICK LEDGE ②

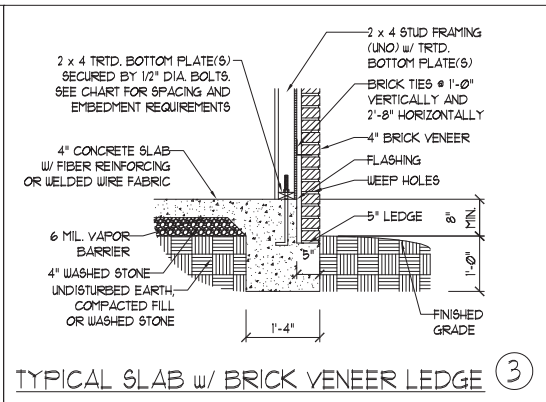

TYPICAL SLAB w/ BRICK VENEER LEDGE ③

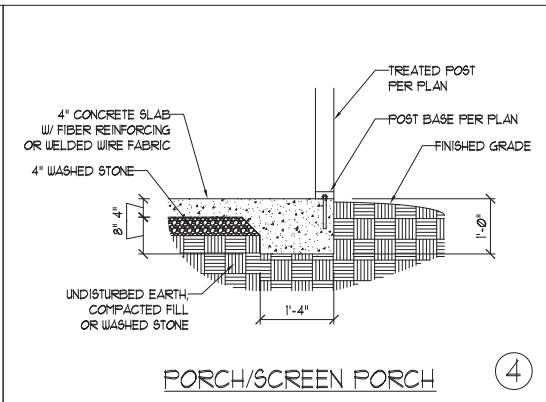

PORCH/SCREEN PORCH ④

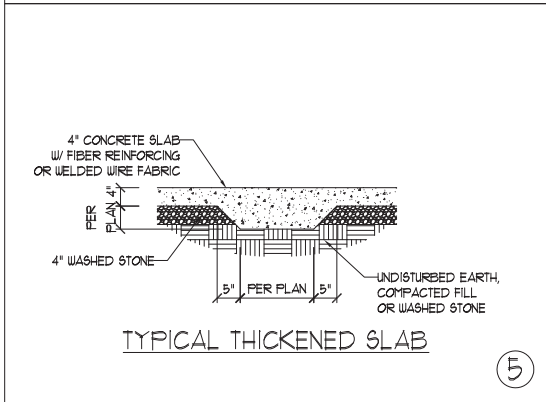

TYPICAL THICKENED SLAB ⑤

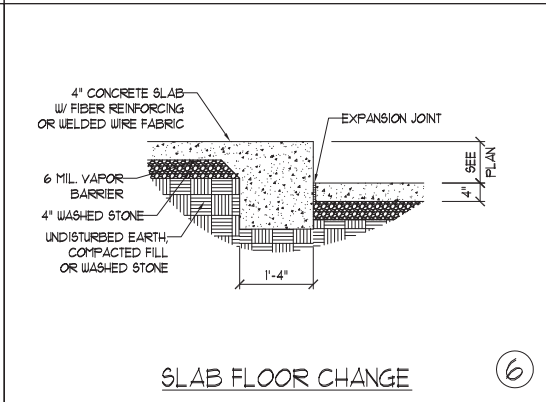

SLAB FLOOR CHANGE ⑥

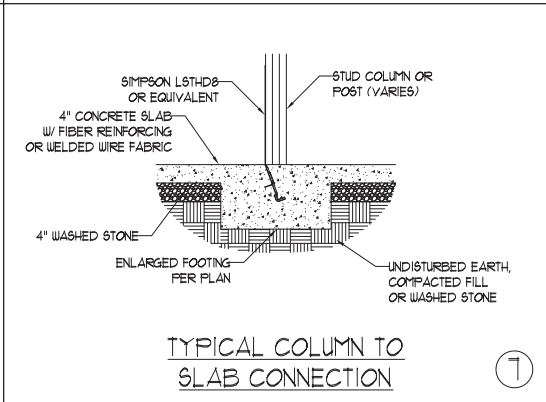

TYPICAL COLUMN TO SLAB CONNECTION ⑦

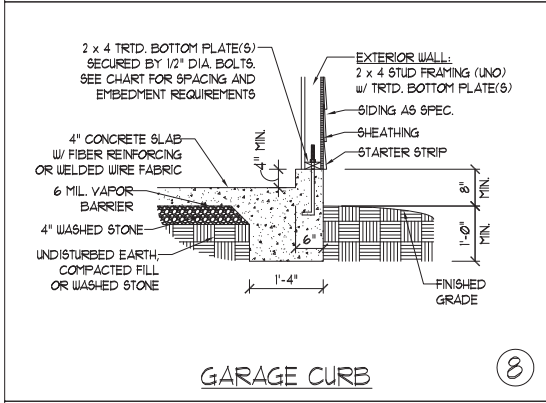

GARAGE CURB ⑧

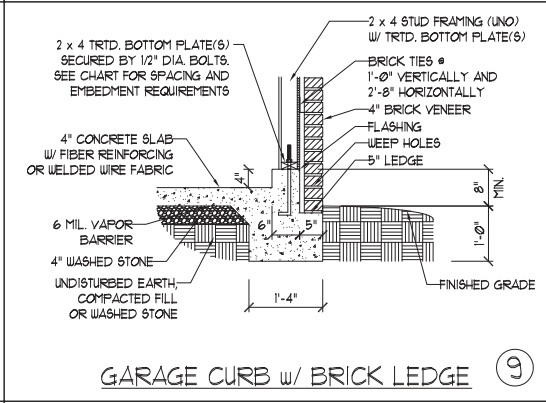

GARAGE CURB w/ BRICK LEDGE ⑨

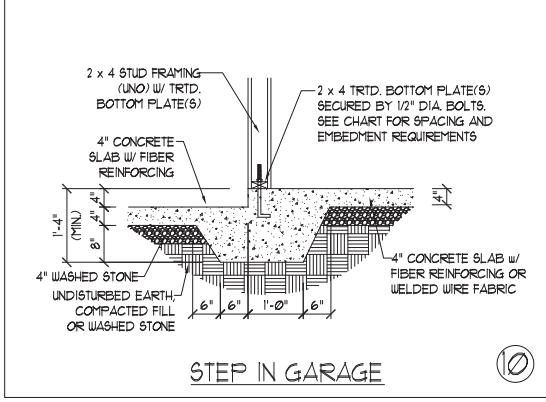

STEP IN GARAGE ⑩

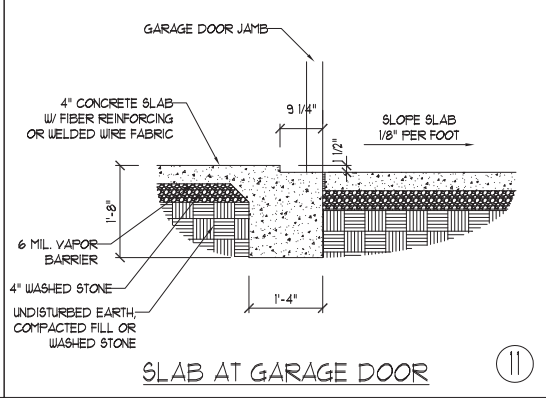

SLAB AT GARAGE DOOR ⑪

ANCHOR SPACING AND EMBEDMENT	
WIND ZONE	120 MPH
SPACING	6'-0" O.C. INSTALL MIN. (2) ANCHORS PER PLATE SECTION AND (1) ANCHOR WITHIN 12" OF CORNERS
EMBEDMENT	7"

NOTE:  
 THREADED ROD WITH EPOXY, SIMPSON TITEN HD, OR APPROVED ANCHORS SPACED AS REQUIRED TO PROVIDE EQUIVALENT ANCHORAGE TO 1/2" DIAMETER ANCHOR BOLTS MAY BE USED IN LIEU OF 1/2" ANCHOR BOLTS.

**J.S. THOMPSON ENGINEERING, INC.**  
 333 EAST SIX FORKS ROAD, SUITE 180 RALEIGH, NC 27609  
 PHONE: (919) 789-9919 FAX: (919) 789-9921  
 N.C. LICENSE NO.: CJ1733

MONOLITHIC SLAB FOUNDATION DETAILS



10/25/2023

This sealed page is to be used in conjunction with a full plan set engineered by J.S. Thompson Engineering, Inc. only. Use of this individual sealed page within architectural pages or shop drawings by others is a punishable offense under N.C. Statute § 89C-23

DATE: AUGUST 30, 2022
SCALE: NTS
DRAWN BY: JST
ENGINEERED BY: JST

FOUNDATION DETAILS

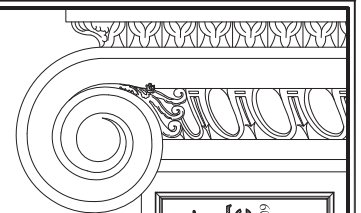

**J.S. THOMPSON  
ENGINEERING, INC**  
333 EAST SIX FORKS ROAD, SUITE 180 RALEIGH, NC 27609  
PHONE: (919) 789-9919 FAX: (919) 789-9921  
N.C. LICENSE NO.: C-1733

STEM WALL  
FOUNDATION DETAILS

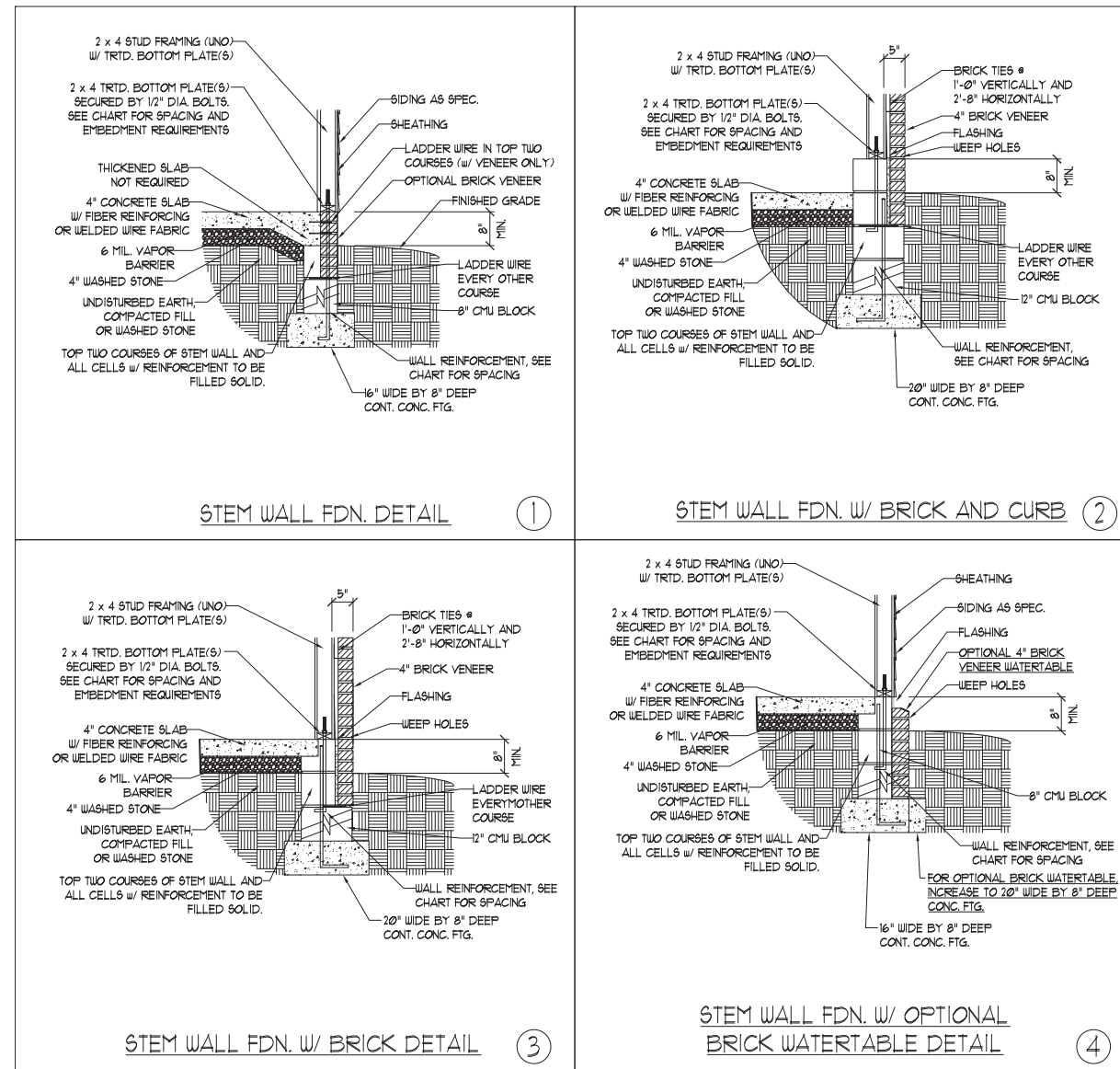

MASONRY STEMWALL SPECIFICATIONS				
WALL HEIGHT (FEET)	MASONRY WALL TYPE			
	8" CMU	4" BRICK AND 4" CMU	4" BRICK AND 8" CMU	12" CMU
2 AND BELOW	UNGROUTED	GROUT SOLID	UNGROUTED	UNGROUTED
3	UNGROUTED	GROUT SOLID	UNGROUTED	UNGROUTED
4	GROUT SOLID	GROUT SOLID w/ #4 REBAR @ 48" O.C.	GROUT SOLID	GROUT SOLID w/ #4 REBAR @ 64" O.C.
5	GROUT SOLID w/ #4 REBAR @ 36" O.C.	NOT APPLICABLE	GROUT SOLID w/ #4 REBAR @ 36" O.C.	GROUT SOLID w/ #4 REBAR @ 64" O.C.
6	GROUT SOLID w/ #4 REBAR @ 24" O.C.	NOT APPLICABLE	GROUT SOLID w/ #4 REBAR @ 24" O.C.	GROUT SOLID w/ #4 REBAR @ 64" O.C.
7 AND GREATER	ENGINEERED DESIGN BASED ON SITE CONDITIONS			

**STRUCTURAL NOTES:**

- 1) WALL HEIGHT MEASURED FROM TOP OF FOOTING TO TOP OF THE WALL.
- 2) TIE MULTIPLE WYTHES TOGETHER WITH LADDER WIRE AT 16" O.C. VERTICALLY.
- 3) CHART APPLICABLE FOR HOUSE FOUNDATION ONLY. CONSULT ENGINEER FOR DESIGN OF GARAGE FOUNDATION NOT COMMON TO HOUSE.
- 4) BACKFILL OF CLEAN #1 / #1 WASHED STONE IS ALLOWABLE.
- 5) BACKFILL OF WELL DRAINED OR SAND - GRAVEL MIXTURE SOILS (45 PSF/FT BELOW GRADE) CLASSIFIED AS GROUP 1 ACCORDING TO UNIFIED SOILS CLASSIFICATION SYSTEM IN ACCORDANCE WITH TABLE R405.1 OF THE 2018 NORTH CAROLINA RESIDENTIAL CODE ARE ALLOWABLE.
- 6) PREP SLAB PER R506.2.1 AND R506.2.2 BASE AND EXCEPTION OF 2018 NORTH CAROLINA RESIDENTIAL CODE.
- 7) MINIMUM 24" LAP SPLICE LENGTH.
- 8) LOCATE REBAR IN CENTER OF FOUNDATION WALL.
- 9) WHERE REQUIRED, FILL BLOCK SOLID WITH TYPE 'S' MORTAR OR 3000 PSI GROUT. USE OF "LOW LIFT GROUTING" METHOD REQUIRED WHEN FILLING WALLS WITH GROUT AT HEIGHTS OF 5' AND GREATER.

ANCHOR SPACING AND EMBEDMENT		
WIND ZONE	120 MPH	130 MPH
SPACING	6'-0" O.C. INSTALL MIN. (2) ANCHORS PER PLATE SECTION AND (1) ANCHOR WITHIN 12" OF CORNERS	4'-0" O.C. INSTALL MIN. (2) ANCHORS PER PLATE SECTION AND (1) ANCHOR WITHIN 12" OF CORNERS
EMBEDMENT	7"	15" INTO MASONRY 7" INTO CONCRETE

**NOTE:**  
THREADED ROD WITH EPOXY, SIMPSON TITEN HD, OR APPROVED ANCHORS SPACED AS REQUIRED TO PROVIDE EQUIVALENT ANCHORAGE TO 1/2" DIAMETER ANCHOR BOLTS MAY BE USED IN LIEU OF 1/2" ANCHOR BOLTS.

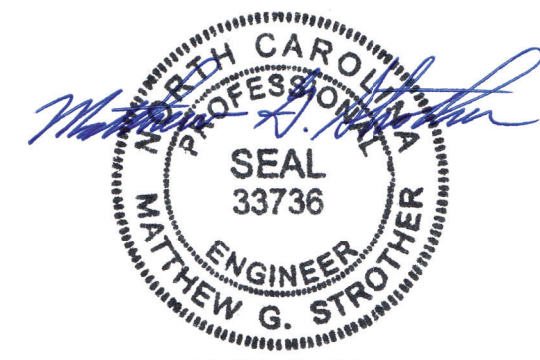

10/25/2023

This sealed page is to be used in conjunction with a full plan set engineered by J.S. Thompson Engineering, Inc. only. Use of this individual sealed page within architectural pages or shop drawings by others is a punishable offense under N.C. Statute § 89C-23

DATE: AUGUST 30, 2022  
SCALE: NTS  
DRAWN BY: JST  
ENGINEERED BY: JST

FOUNDATION  
DETAILS



**GENERAL WALL BRACING NOTES:**

1. WALL BRACING DESIGNED IN ACCORDANCE WITH CHAPTER 6 OF THE 2018 NC RESIDENTIAL BUILDING CODE (NRC). TABLES AND FIGURES REFERENCED ARE FROM THE 2018 NRC.
2. SEE THIS SHEET FOR GENERAL DETAILS. REFER TO THE 2018 NRC FOR ADDITIONAL INFORMATION AS NEEDED.
3. BRACED EXTERIOR WALLS SUPPORTING ROOF TRUSSES AND RAFTERS, INCLUDING STORIES BELOW THE TOP FLOOR, HAVE BEEN DESIGNED PER R602.3.5 (3). WALL SHEATHING AND FASTENERS HAVE BEEN DESIGNED TO RESIST COMBINED UPLIFT AND SHEAR FORCES IN ACCORDANCE WITH ACCEPTED ENGINEERED PRACTICE.
4. SEE STRUCTURAL SHEETS FOR BRACED WALL LOCATIONS, DIMENSIONS, HOLD DOWN TYPE AND LOCATIONS, BRACED WALL LINE KEY WITH WALL DESIGN SUMMARY OF REQUIRED/PROVIDED TOTALS FOR EACH WALL LINE AND ANY SPECIAL NOTES OR REQUIREMENTS.
5. ALL EXTERIOR WALLS ARE TO BE SHEATHED WITH CS-WSP IN ACCORDANCE WITH SECTION R602.10.3 UNLESS NOTED OTHERWISE.
6. ALL EXTERIOR AND INTERIOR WALLS TO HAVE 1/2" GYPSUM INSTALLED. WHEN NOT USING METHOD "GB", GYPSUM TO BE FASTENED PER TABLE R702.3.5. METHOD GB TO BE FASTENED PER TABLE R602.10.1
7. CS-WSP REFERS TO THE "CONTINUOUS SHEATHING - WOOD STRUCTURAL PANELS" WALL BRACING METHOD. 7/16" OSB SHEATHING IS TO BE INSTALLED ON ALL EXTERIOR WALLS ATTACHED w/ 6d COMMON NAILS OR 8d (2 1/2" LONG x 0.113" DIAMETER) NAILS SPACED 6" O.C. ALONG PANEL EDGES AND 12" O.C. IN THE FIELD (U.N.O.).
8. GB REFERS TO THE "GYPSUM BOARD" WALL BRACING METHOD. 1/2" (MIN.) GYPSUM WALL BOARD IS TO BE INSTALLED ON BOTH SIDES OF THE BRACED WALL FASTENED WITH 1 1/4" SCREWS OR 1 5/8" NAILS SPACED 7" O.C. ALONG PANEL EDGES INCLUDING TOP AND BOTTOM PLATES AND INTERMEDIATE SUPPORTS (U.N.O.). VERIFY ALL FASTENER OPTIONS FOR 1/2" AND 5/8" GYPSUM PRIOR TO CONSTRUCTION. FOR INTERIOR FASTENER OPTIONS SEE TABLE R702.3.5. FOR EXTERIOR FASTENER OPTIONS SEE TABLE R602.3(1). EXTERIOR GB TO BE INSTALLED VERTICALLY.
9. REQUIRED BRACED WALL LENGTH FOR EACH SIDE OF THE CIRCUMSCRIBED RECTANGLE ARE INTERPOLATED PER TABLE R602.10.3. METHOD CS-WSP CONTRIBUTES ITS ACTUAL LENGTH, METHOD GB CONTRIBUTES .5 ITS ACTUAL LENGTH, AND METHOD PF CONTRIBUTES 1.5 TIMES ITS ACTUAL LENGTH.

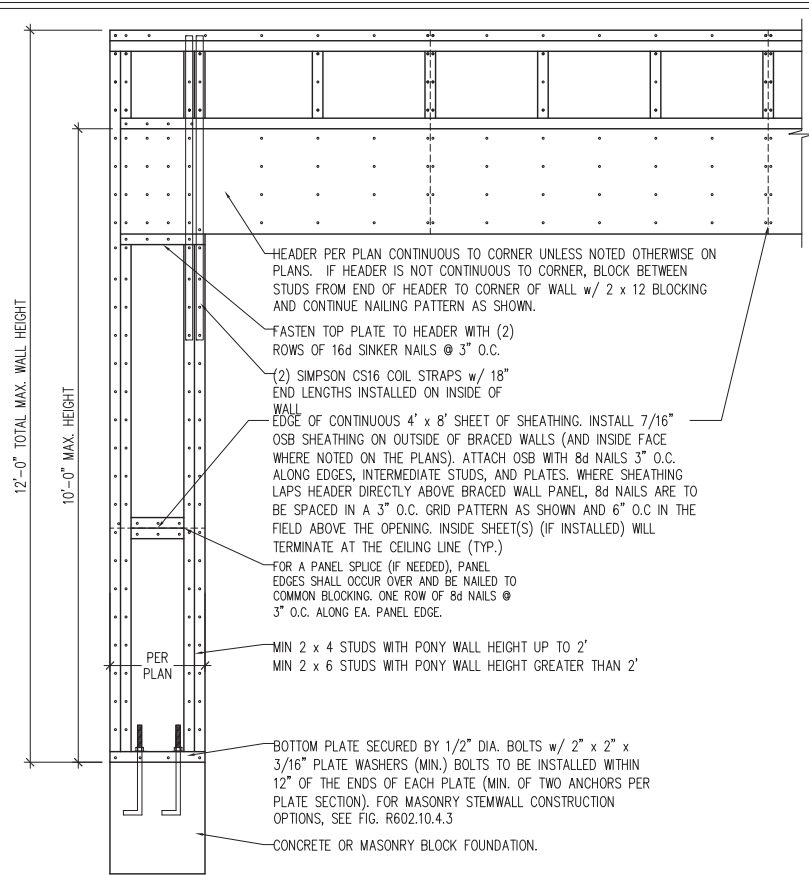

OVER CONCRETE OR MASONRY BLOCK FOUNDATION

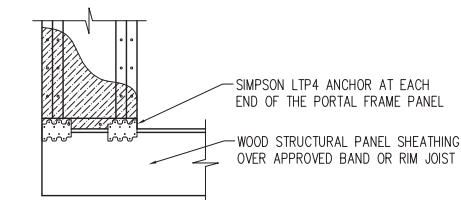

OVER RAISED WOOD FLOOR - FRAMING ANCHOR OPTION  
\* APPLICABLE w/ GREATER THAN 12" KNEE WALL HEIGHTS IN CRAWL SPACE AND ABOVE FRAMED BASEMENT WALLS \*

**METHOD PF-PORTAL FRAME DETAIL ①**

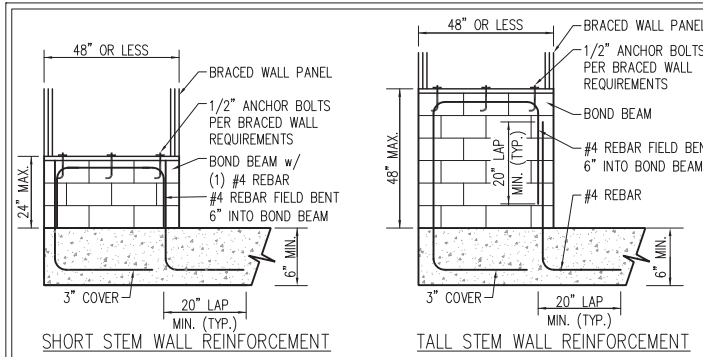

SHORT STEM WALL REINFORCEMENT

TALL STEM WALL REINFORCEMENT

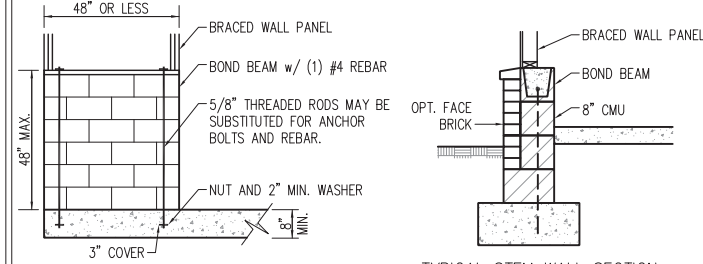

OPTIONAL STEM WALL REINFORCEMENT

TYPICAL STEM WALL SECTION

NOTE: GROUT BOND BEAMS AND ALL CELLS WHICH CONTAIN REBAR, THREADED RODS AND ANCHOR BOLTS

**MASONRY STEM WALLS SUPPORTING BRACED WALL PANELS ②**

PER FIGURE R602.10.4.3

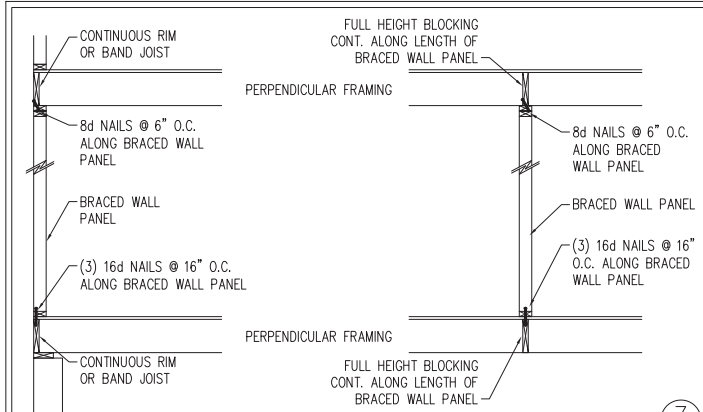

**BRACED WALL PANEL CONNECTION WHEN PERPENDICULAR TO FLOOR/CEILING FRAMING ③**

PER FIGURE R602.10.4.4(1)

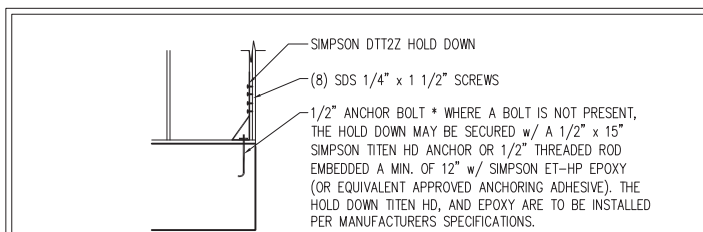

**HOLD DOWN DETAIL FOR MASONRY FOUNDATION OR MONOLITHIC SLAB ④**

\* APPLICABLE ONLY WHERE SPECIFIED ON PLAN \*

**TYPICAL EXTERIOR CORNER FRAMING FOR CONTINUOUS SHEATHING ⑤**

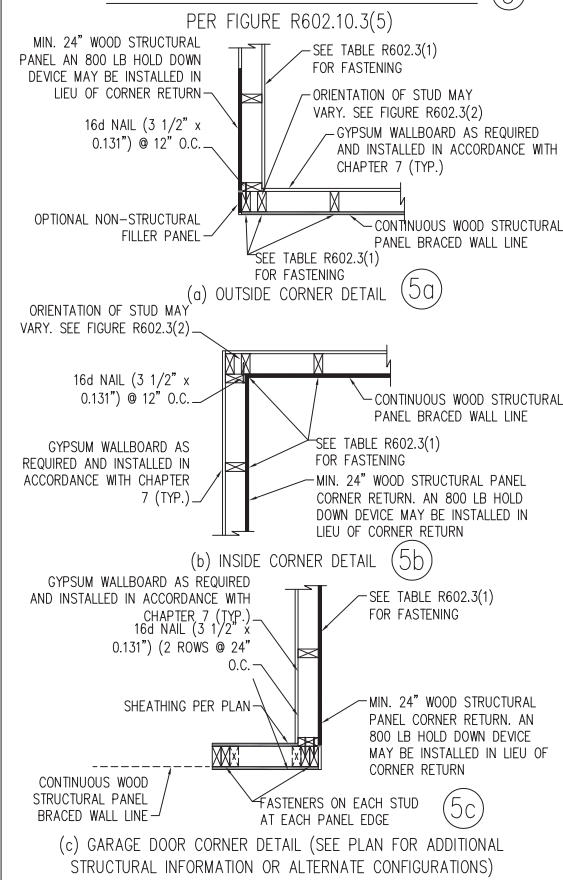

**BRACED WALL PANEL CONNECTION WHEN PARALLEL TO FLOOR/CEILING FRAMING ⑥**

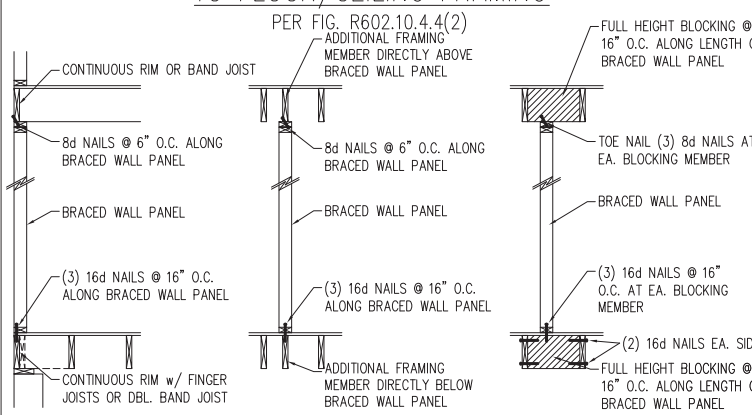

SCALE NOTE:  
LARGE FORMAT PRINTS ARE TO SCALE AS NOTED.  
11" x 17" PRINTS ARE ONE HALF THE NOTED SCALE

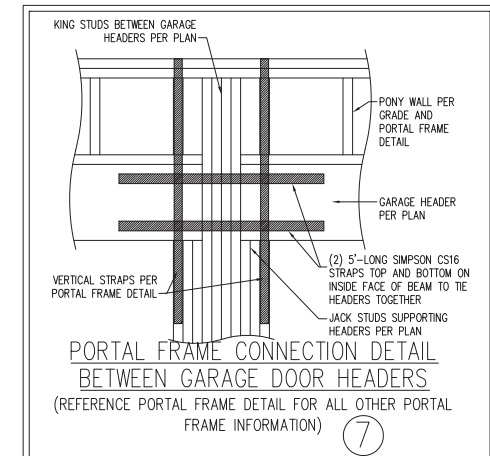

**BRACED WALL PANEL CONNECTION TO PERPENDICULAR RAFTERS ⑧**

PER FIGURE R602.10.4.5(1)

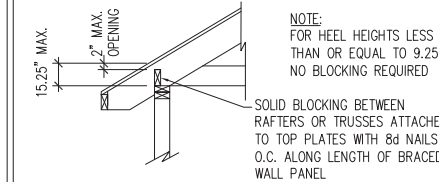

**BRACED WALL PANEL CONNECTION TO PERPENDICULAR ROOF TRUSSES ⑨**

PER FIGURE R602.10.4.5(3) (OR ALTERNATIVE: FIGURE R602.10.4.5(2))

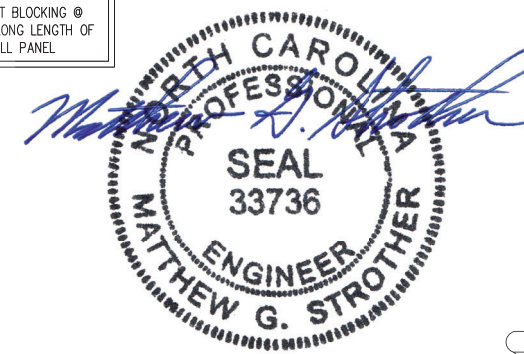
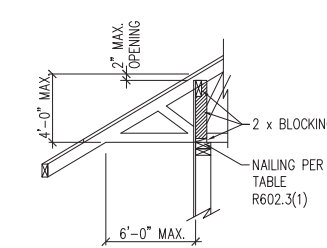

**J.S. THOMPSON ENGINEERING, INC**  
331 EAST SIX FORKS ROAD, SUITE 100, RALEIGH, NC 27609  
PHONE: (919) 789-9119 FAX: (919) 789-9121  
N.C. LICENSE NO. C173

WALL BRACING NOTES AND DETAILS

DATE: AUGUST 10, 2022  
SCALE: 1/4" = 1'-0"  
DRAWN BY: JST  
ENGINEERED BY: JST

BRACED WALL NOTES AND DETAILS AND PF DETAILS

10/25/2023

This sealed page is to be used in conjunction with a full plan set engineered by J.S. Thompson Engineering, Inc. Only use of this individual sealed page within architectural pages or shop drawings by others is a punishable offense under N.C. Statute § 89C-23

SCALE NOTE:  
LARGE FORMAT PRINTS ARE TO SCALE AS NOTED.  
11" x 17" PRINTS ARE ONE HALF THE NOTED SCALE

GENERAL NOTES

- ENGINEER'S SEAL APPLIES ONLY TO STRUCTURAL COMPONENTS INCLUDING ROOF RAFTERS, HIPS, VALLEYS, RIDGES, FLOORS, WALLS, BEAMS, HEADERS, COLUMNS, CANTILEVERS, OFFSET LOAD BEARING WALLS, PIERS, GIRDER SYSTEM AND FOOTING. ENGINEER'S SEAL DOES NOT CERTIFY DIMENSIONAL ACCURACY OF ARCHITECTURAL LAYOUT INCLUDING ROOF. ENGINEER'S SEAL DOES NOT APPLY TO I-JOIST OR FLOOR/ROOF TRUSS LAYOUT DESIGN AND ACCURACY.
- ALL CONSTRUCTION SHALL CONFORM TO THE LATEST REQUIREMENTS OF THE NORTH CAROLINA RESIDENTIAL CODE (NRCR), 2018 EDITION, PLUS ALL LOCAL CODES AND REGULATIONS. THE STRUCTURAL ENGINEER IS NOT RESPONSIBLE FOR, AND WILL NOT HAVE CONTROL OF, CONSTRUCTION MEANS, METHODS, TECHNIQUES, SEQUENCES OR PROCEDURES, OR SAFETY PRECAUTIONS AND PROGRAMS IN CONNECTION WITH THE CONSTRUCTION WORK. NOR WILL THE ENGINEER BE RESPONSIBLE FOR THE CONTRACTORS FAILURE TO CARRY OUT THE CONSTRUCTION WORK IN ACCORDANCE WITH THE CONTRACT DOCUMENTS.
- STRUCTURAL DESIGN BASED ON THE PROVISIONS OF THE NRCR, 2018 EDITION (R301.4 - R301.7)

DESIGN CRITERIA:	LIVE LOAD (PSF)	DEAD LOAD (PSF)	DEFLECTION (IN)
ATTIC WITH LIMITED STORAGE	20	10	L/240 (L/360 w/ BRITTLE FINISHES)
ATTIC WITHOUT STORAGE	10	10	L/360
DECKS	40	10	L/360
EXTERIOR BALCONIES	40	10	L/360
FIRE ESCAPES	40	10	L/360
HANDRAILS/GUARDRAILS	200	10	L/360
PASSENGER VEHICLE GARAGE	50	10	L/360
ROOMS OTHER THAN SLEEPING ROOM	40	10	L/360
SLEEPING ROOMS	30	10	L/360
STAIRS	40	10	L/360
WIND LOAD	(BASED ON TABLE R301.2(4) WIND ZONE AND EXPOSURE)		
GROUND SNOW LOAD: P <sub>g</sub>	20 (PSF)		

- I-JOIST SYSTEMS DESIGNED WITH 12 PSF DEAD LOAD AND DEFLECTION (IN) OF L/480
- FLOOR TRUSS SYSTEMS DESIGNED WITH 15 PSF DEAD LOAD

- FOR 115 AND 120 MPH WIND ZONES, FOUNDATION ANCHORAGE IS TO COMPLY WITH SECTION R403.1.6 OF THE NRCR, 2018 EDITION. FOR 130 MPH, 140 MPH, AND 150 MPH WIND ZONES, FOUNDATION ANCHORAGE IS TO COMPLY WITH SECTION 4504 OF THE NRCR, 2018 EDITION.
- ENERGY EFFICIENCY COMPLIANCE AND INSULATION VALUES OF THE BUILDING TO BE IN ACCORDANCE WITH CHAPTER 11 OF THE NRCR, 2018 EDITION.

FOOTING AND FOUNDATION NOTES

- FOUNDATION DESIGN BASED ON A MINIMUM ALLOWABLE BEARING CAPACITY OF 2000 PSF. CONTACT GEOTECHNICAL ENGINEER IF BEARING CAPACITY IS NOT ACHIEVED.
- FOR ALL CONCRETE SLABS AND FOOTINGS, THE AREA WITHIN THE PERIMETER OF THE BUILDING ENVELOPE SHALL HAVE ALL VEGETATION, TOP SOIL AND FOREIGN MATERIAL REMOVED. FILL MATERIAL SHALL BE FREE OF VEGETATION AND FOREIGN MATERIAL. THE FILL SHALL BE COMPACTED TO ASSURE UNIFORM SUPPORT OF THE SLAB, AND EXCEPT WHERE APPROVED, THE FILL DEPTHS SHALL NOT EXCEED 24" FOR CLEAN SAND OR GRAVEL. A 4" THICK BASED COURSE CONSISTING OF CLEAN GRADED SAND OR GRAVEL SHALL BE PLACED. A BASE COURSE IS NOT REQUIRED WHERE A CONCRETE SLAB IS INSTALLED ON WELL-DRAINED OR SAND-GRAVEL MIXTURE SOILS CLASSIFIED AS GROUP 1, ACCORDING TO THE UNITED SOIL CLASSIFICATION SYSTEM IN ACCORDANCE WITH TABLE R405.1 OF THE NRCR, 2018 EDITION.
- PROPERLY DEWATER EXCAVATION PRIOR TO POURING CONCRETE WHEN BOTTOM OF CONCRETE SLAB IS AT OR BELOW WATER TABLE. IF APPLICABLE, 3/4" - 1" DEEP CONTROL JOINTS ARE TO BE SAWED WITHIN 4 TO 12 HOURS OF CONCRETE FINISHING AND WALL LOCATIONS HAVE BEEN MARKED. ADJUST WHERE NECESSARY.
- CONCRETE SHALL CONFORM TO SECTION R402.2 OF THE NRCR, 2018 EDITION. CONCRETE REINFORCING STEEL TO BE ASTM A615 GRADE 60. WELDED WIRE FABRIC TO BE ASTM A185. MAINTAIN A MINIMUM CONCRETE COVER AROUND REINFORCING STEEL OF 3" IN FOOTINGS AND 1 1/2" IN SLABS. FOR POURED CONCRETE WALLS, CONCRETE COVER FOR REINFORCING STEEL MEASURED FROM THE INSIDE FACE OF THE WALL SHALL NOT BE LESS THAN 3/4". CONCRETE COVER FOR REINFORCING STEEL MEASURED FROM THE OUTSIDE FACE OF THE WALL SHALL NOT BE LESS THAN 1 1/2" FOR #5 BARS OR SMALLER, AND NOT LESS THAN 2" FOR #6 BARS OR LARGER.
- MASONRY UNITS TO CONFORM TO ACE 530/ASCE 5/TMS 402. MORTAR SHALL CONFORM TO ASTM C270.
- THE UNSUPPORTED HEIGHT OF MASONRY PIERS SHALL NOT EXCEED FOUR TIMES THEIR LEAST DIMENSION FOR UNFILLED HOLLOW CONCRETE MASONRY UNITS AND TEN TIMES THEIR LEAST DIMENSION FOR SOLID OR SOLID FILLED PIERS. PERS MAY BE FILLED SOLID WITH CONCRETE OR TYPE M OR S MORTAR. PIERS AND WALLS SHALL BE CAPPED WITH 8" OF SOLID MASONRY.
- THE CENTER OF EACH OF THE PIERS SHALL BEAR IN THE MIDDLE THIRD OF ITS RESPECTIVE FOOTING. EACH GIRDER SHALL BEAR IN THE MIDDLE THIRD OF THE PIERS.
- ALL CONCRETE AND MASONRY FOUNDATION WALLS ARE TO BE CONSTRUCTED IN ACCORDANCE WITH THE PROVISIONS OF SECTION R404 OF THE NRCR, 2018 EDITION OR IN ACCORDANCE WITH ACI 318, ACI 332, NCMA TR68-A OR ACE 530/ASCE 5/TMS 402. MASONRY FOUNDATION WALLS ARE TO BE REINFORCED PER TABLE R404.1.1(1), R404.1.1(2), R404.1.1(3), OR R404.1.1(4) OF THE NRCR, 2018 EDITION. CONCRETE FOUNDATION WALLS ARE TO BE REINFORCED PER TABLE R404.1.1(5) OF THE NRCR, 2018 EDITION. STEP CONCRETE FOUNDATION WALLS TO 2 x 6 FRAMED WALLS AT 16" O.C. WHERE GRADE PERMITS (UNO).

This sealed page is to be used in conjunction with a full plan set engineered by J.S. Thompson Engineering, Inc. only. Use of this individual sealed page within architectural pages or shop drawings by others is a punishable offense under N.C. Statute § 89C-23

FRAMING NOTES

- ALL FRAMING LUMBER SHALL BE #2 SPF MINIMUM (F<sub>b</sub> = 875 PSI, F<sub>v</sub> = 375 PSI, E = 1600000 PSI) UNLESS NOTED OTHERWISE (UNO). ALL TREATED LUMBER SHALL BE #2 SYP MINIMUM (F<sub>b</sub> = 975 PSI, F<sub>v</sub> = 175 PSI, E = 1600000 PSI) UNLESS NOTED OTHERWISE (UNO).
- LAMINATED VENEER LUMBER (LVL) SHALL HAVE THE FOLLOWING MINIMUM PROPERTIES: F<sub>b</sub> = 2600 PSI, F<sub>v</sub> = 285 PSI, E = 1900000 PSI. LAMINATED STRAND LUMBER (LSL) SHALL HAVE THE FOLLOWING MINIMUM PROPERTIES: F<sub>b</sub> = 2325 PSI, F<sub>v</sub> = 310 PSI, E = 1550000 PSI. PARALLEL STRAND LUMBER (PSL) UP TO 7" DEPTH SHALL HAVE THE FOLLOWING MINIMUM PROPERTIES: F<sub>c</sub> = 2500 PSI, E = 1800000 PSI. PARALLEL STRAND LUMBER (PSL) MORE THAN 7" DEPTH SHALL HAVE THE FOLLOWING MINIMUM PROPERTIES: F<sub>c</sub> = 2900 PSI, E = 2000000 PSI. INSTALL ALL CONNECTIONS PER MANUFACTURER'S SPECIFICATIONS.
- STRUCTURAL STEEL SHALL CONFORM TO THE FOLLOWING ASTM SPECIFICATIONS
 

A. W AND WT SHAPES:	ASTM A992
B. CHANNELS AND ANGLES:	ASTM A36
C. PLATES AND BARS:	ASTM A36
D. HOLLOW STRUCTURAL SECTIONS:	ASTM A500 GRADE B
E. STEEL PIPE:	ASTM A53, GRADE B, TYPE E OR S

STEEL BEAMS SHALL BE SUPPORTED AT EACH END WITH A MINIMUM BEARING LENGTH OF 3 1/2" AND FULL FLANGE WIDTH (UNO). PROVIDE SOLID BEARING FROM BEAM SUPPORT TO FOUNDATION. BEAMS SHALL BE ATTACHED AT THE BOTTOM FLANGE TO EACH SUPPORT AS FOLLOWS (UNO):

- |                            |  |
|----------------------------|--|
| A. WOOD FRAMING            | (2) 1/2" DIA. x 4" LONG LAG SCREWS               |
| B. CONCRETE                | (2) 1/2" DIA. x 4" WEDGE ANCHORS                 |
| C. MASONRY (FULLY GROUTED) | (2) 1/2" DIA. x 4" LONG SIMPSON TITEN HD ANCHORS |
| D. STEEL PIPE COLUMN       | (4) 3/4" DIA. A325 BOLTS OR 3/16" FILLET WELD    |

LATERAL SUPPORT IS CONSIDERED ADEQUATE PROVIDING THE JOISTS ARE TOE NAILED TO THE 2x NAILER ON TOP OF THE STEEL BEAM, AND THE 2x NAILER IS SECURED TO THE TOP OF THE STEEL BEAM w/ (2) ROWS OF SELF TAPPING SCREWS @ 16" O.C. OR (2) ROWS OF 1/2" DIAMETER BOLTS @ 16" O.C. IF 1/2" BOLTS ARE USED TO FASTEN THE NAILER, THE STEEL BEAM SHALL BE FABRICATED w/ (2) ROWS OF 9/16" DIAMETER HOLES @ 16" O.C.

- SQUARES DENOTE POINT LOADS WHICH REQUIRE SOLID BLOCKING TO GIRDER OR FOUNDATION. SHADED SQUARES DENOTE POINT LOADS FROM ABOVE WHICH REQUIRE SOLID BLOCKING TO SUPPORTING MEMBER BELOW.
- ALL LOAD BEARING HEADERS TO CONFORM TO TABLE R602.7(1) AND R602.7(2) OF THE NRCR, 2018 EDITION OR BE (2) 2 x 6 WITH (1) JACK AND (1) KING STUD EACH END (UNO), WHICHEVER IS GREATER ALL HEADERS TO BE SECURED TO EACH JACK STUD WITH (4) 8d NAILS. ALL BEAMS TO BE SUPPORTED WITH (2) STUDS AT EACH BEARING POINT (UNO). INSTALL KING STUDS PER SECTION R602.7.5 OF THE NORTH CAROLINA RESIDENTIAL CODE, 2018 EDITION.
- ALL BEAMS, HEADERS, OR GIRDER TRUSSES PARALLEL TO WALL ARE TO BEAR FULLY ON (1) JACK OR (2) STUDS MINIMUM OR THE NUMBER OF JACKS OR STUDS NOTED. ALL BEAMS OR GIRDER TRUSSES PERPENDICULAR TO WALL AND SUPPORTED BY (3) STUDS OR LESS ARE TO HAVE 1 1/2" MINIMUM BEARING (UNO). ALL BEAMS OR GIRDER TRUSSES PERPENDICULAR TO WALL AND SUPPORTED BY MORE THAN (3) STUDS OR OTHER NOTED COLUMN ARE TO BEAR FULLY ON SUPPORT COLUMN FOR ENTIRE WALL DEPTH (UNO). BEAM ENDS THAT BUTT INTO ONE ANOTHER ARE TO EACH BEAR EQUAL LENGTHS (UNO).
- FLITCH BEAMS SHALL BE BOLTED TOGETHER USING 1/2" DIAMETER BOLTS (ASTM A307) WITH WASHERS PLACED AT THREADED END OF BOLT. BOLTS SHALL BE SPACED AT 24" CENTERS (MAXIMUM), AND STAGGERED AT TOP AND BOTTOM OF BEAM (2" EDGE DISTANCE), WITH (2) BOLTS LOCATED AT 6" FROM EACH END (UNO).
- ALL I-JOIST OR TRUSS LAYOUTS ARE TO BE IN COMPLIANCE WITH THE OVERALL DESIGN SPECIFIED ON THE PLANS. ALL DEVIATIONS ARE TO BE BROUGHT TO THE ATTENTION OF THE ENGINEER OF RECORD PRIOR TO INSTALLATION.
- BRACED WALL PANELS SHALL BE CONSTRUCTED ACCORDING TO THE NORTH CAROLINA RESIDENTIAL CODE 2018 EDITION WALL BRACING CRITERIA. THE AMOUNT, LENGTH, AND LOCATION OF BRACING SHALL COMPLY WITH ALL APPLICABLE TABLES IN SECTION R602.10.
- PROVIDE DOUBLE JOIST UNDER ALL WALLS PARALLEL TO FLOOR JOISTS. PROVIDE SUPPORT UNDER ALL WALLS PARALLEL TO FLOOR TRUSSES OR I-JOISTS PER MANUFACTURER'S SPECIFICATIONS. INSTALL BLOCKING BETWEEN JOISTS OR TRUSSES FOR POINT LOAD SUPPORT FOR ALL POINT LOADS ALONG OFFSET LOAD LINES.
- FOR ALL HEADERS SUPPORTING BRICK VENEER THAT ARE LESS THAN 8'-0" IN LENGTH, REST A 6" x 4" x 5/16" STEEL ANGLE WITH 6" MINIMUM EMBEDMENT AT SIDES FOR BRICK SUPPORT (U.N.O). FOR ALL HEADERS 8'-0" AND GREATER IN LENGTH, BOLT A 6" x 4" x 5/16" STEEL ANGLE TO HEADER WITH 1/2" LAG SCREWS AT 12" O.C. STAGGERED FOR BRICK SUPPORT. FOR ALL BRICK SUPPORT AT ROOF LINES, BOLT A 6" x 4" x 5/16" STEEL ANGLE TO (2) 2 x 10 BLOCKING INSTALLED w/ (4) 12d NAILS EA. PLY BETWEEN WALL STUDS WITH (2) ROWS OF 1/2" LAG SCREWS AT 12" O.C. STAGGERED AND IN ACCORDANCE WITH SECTION R703.8.2.1 OF THE NRCR, 2018 EDITION.
- FOR STICK FRAMED ROOFS: CIRCLES DENOTE (3) 2 x 4 POSTS FOR ROOF MEMBER SUPPORT. HIP SPLICES ARE TO BE SPACED A MINIMUM OF 8'-0". FASTEN MEMBERS WITH THREE ROWS OF 12d NAILS AT 16" O.C. FRAME DORMER WALLS ON TOP OF DOUBLE OR TRIPLE RAFTERS AS SHOWN (UNO).
- FOR TRUSSED ROOFS: FRAME DORMER WALLS ON TOP OF 2 x 4 LADDER FRAMING AT 24" O.C. BETWEEN ADJACENT ROOF TRUSSES. STICK FRAME OVER-FRAMED ROOF SECTIONS WITH 2 x 8 RIDGES, 2 x 6 RAFTERS AT 16" O.C. AND FLAT 2 x 10 VALLEYS (UNO).
- ALL 4 x 4 AND 6 x 6 POSTS TO BE INSTALLED WITH 700 LB CAPACITY UPLIFT CONNECTORS TOP AND BOTTOM (UNO). POSTS MAY BE SECURED USING ONE SIMPSON H6 OR LTS12 UPLIFT CONNECTOR FASTENED TO THE BAND AT THE BOTTOM AND THE BEAM AT THE TOP OF EACH POST. ONE 16" SECTION OF SIMPSON CS16 COIL STRAPPING WITH (8) 8d HDG NAILS AT EACH END MAY BE USED IN LIEU OF EACH TWIST STRAP IF DESIRED. FOR MASONRY OR CONCRETE FOUNDATION USE SIMPSON POST BASE.

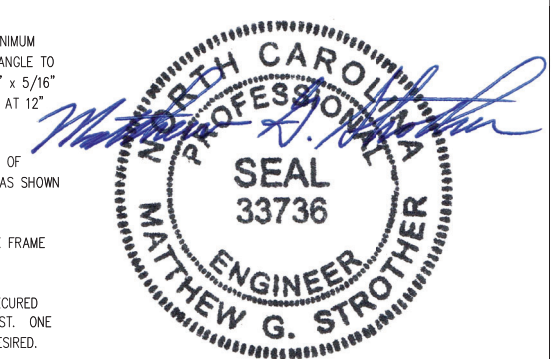

10/25/2023

**J.S. THOMPSON**  
**ENGINEERING, INC**  
333 EAST SIX FORKS ROAD, SUITE 180, RALEIGH, NC 27609  
PHONE: (919) 789-9919 FAX: (919) 789-9921  
N.C. LICENSE NO.: CJ133

STANDARD STRUCTURAL NOTES

DATE: AUGUST 30, 2022  
DRAWN BY: JST  
ENGINEERED BY: JST

STRUCTURAL NOTES

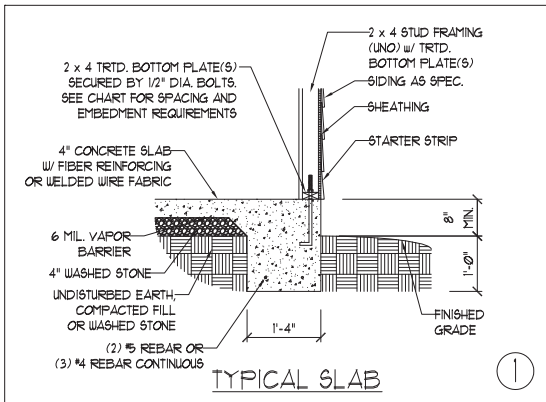

①

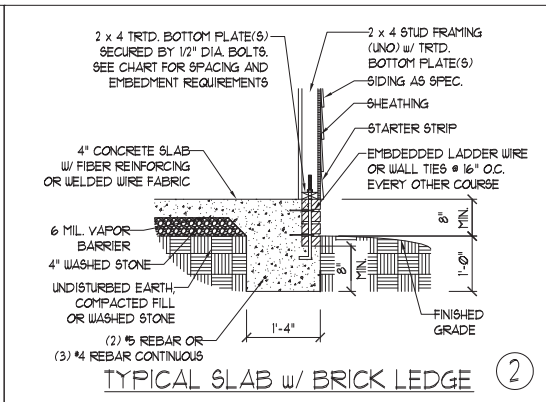

②

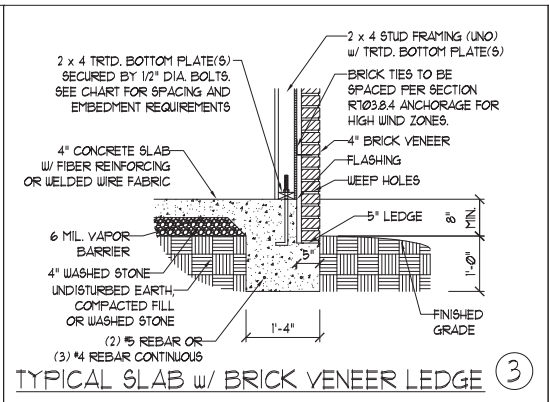

③

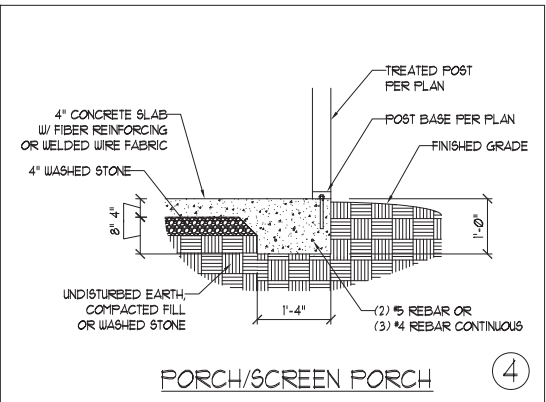

④

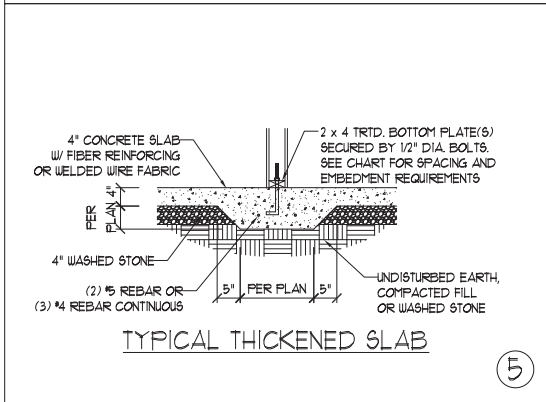

⑤

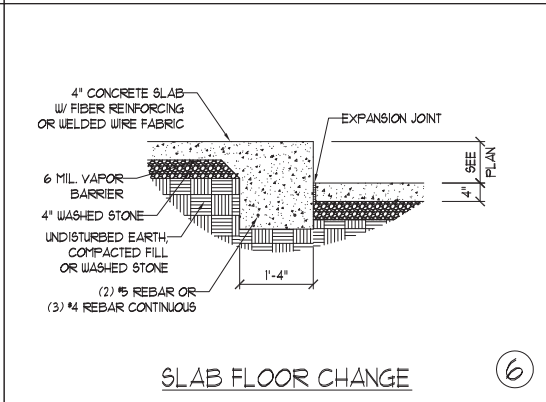

⑥

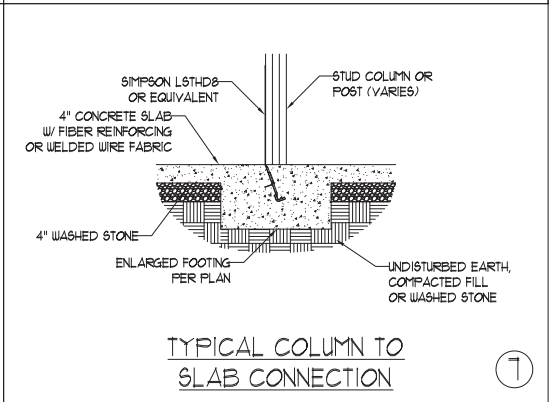

⑦

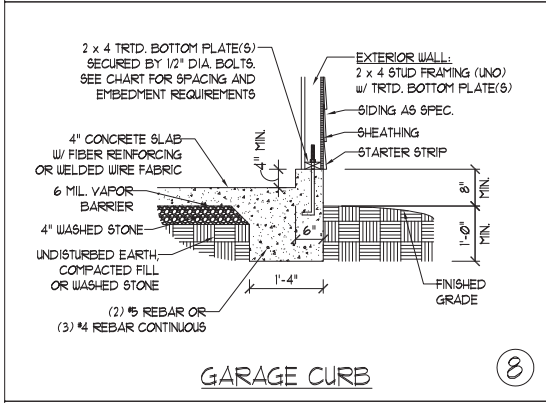

⑧

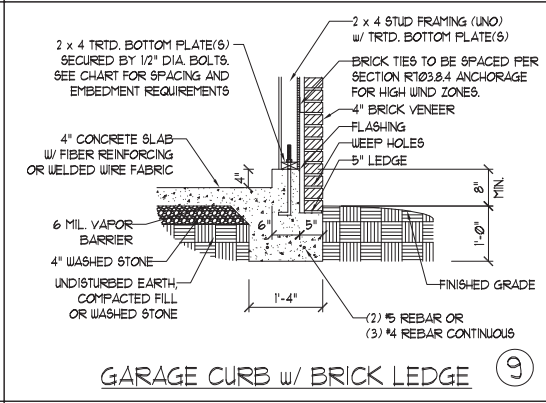

⑨

NOTE:  
LOCATE REBAR 3\"/>

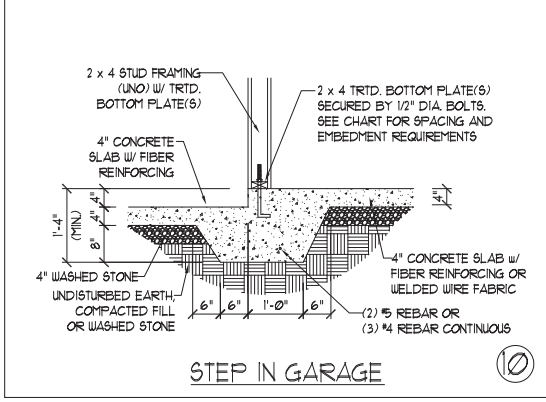

⑩

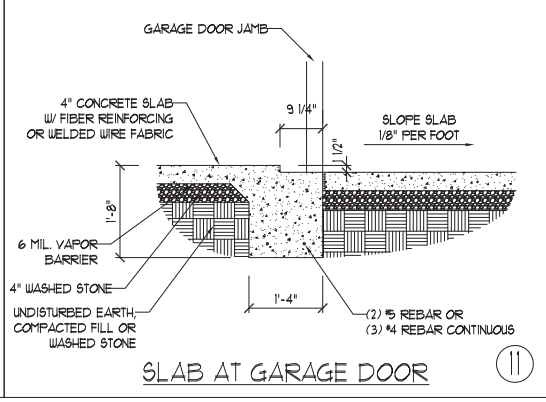

⑪

ANCHOR SPACING AND EMBEDMENT		
WIND ZONE	140 MPH	150 MPH
SPACING	6'-0" O.C. w/ DBL. SILL PLATE OR 1'-9" O.C. w/ SINGLE SILL PLATE w/ 2" x 2" x 1/8" WASHERS. INSTALL MIN. (2) ANCHORS PER PLATE SECTION AND (1) ANCHOR WITHIN 12" OF CORNERS	6'-0" O.C. w/ DBL. SILL PLATE OR 1'-6" O.C. w/ SINGLE SILL PLATE w/ 2" x 2" x 1/8" WASHERS. INSTALL MIN. (2) ANCHORS PER PLATE SECTION AND (1) ANCHOR WITHIN 12" OF CORNERS
EMBEDMENT	7"	7"

NOTE:  
THREADED ROD WITH EPOXY, SIMPSON TITEN HD, OR APPROVED ANCHORS SPACED AS REQUIRED TO PROVIDE EQUIVALENT ANCHORAGE TO 1/2" DIAMETER ANCHOR BOLTS MAY BE USED IN LIEU OF 1/2" ANCHOR BOLTS.

This sealed page is to be used in conjunction with a full plan set engineered by J.S. Thompson Engineering, Inc. only. Use of this individual sealed page within architectural pages or shop drawings by others is a punishable offense under N.C. Statute § 89C-23

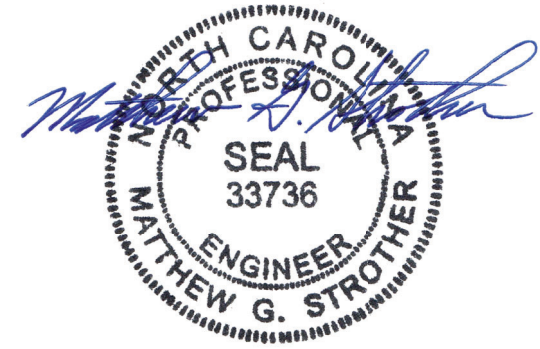

10/25/2023

**J.S. THOMPSON ENGINEERING, INC.**  
333 EAST SIX FORKS ROAD, SUITE 180 RALEIGH, NC 27609  
PHONE: (919) 789-9919 FAX: (919) 789-9921  
N.C. LICENSE NO.: CJ1733

140 MPH - 150 MPH ULTIMATE DESIGN WIND SPEED  
MONOLITHIC SLAB FOUNDATION DETAILS

DATE: AUGUST 30, 2022  
SCALE: NTS  
DRAWN BY: JST  
ENGINEERED BY: JST

FOUNDATION DETAILS

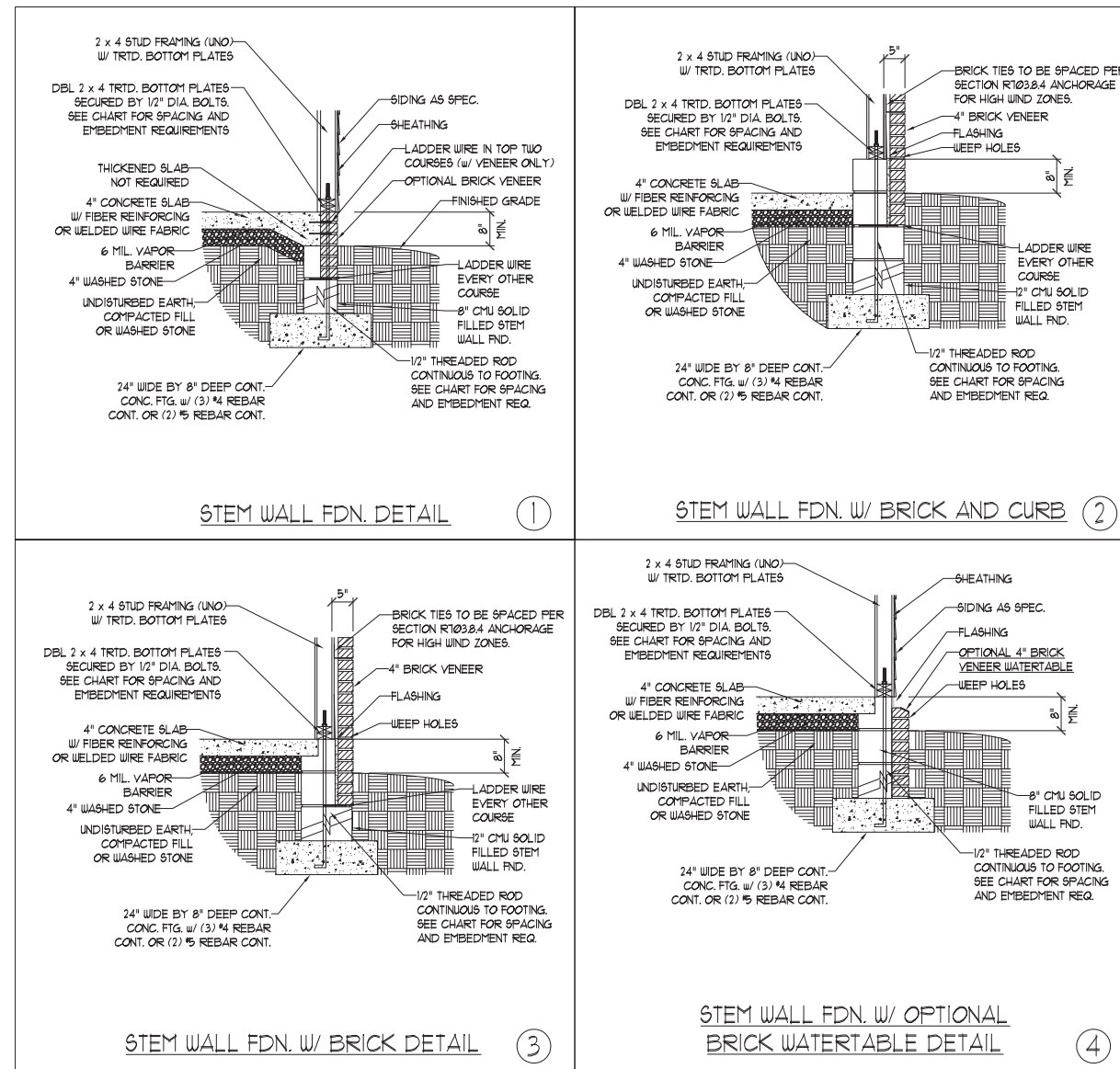

MASONRY STEMWALL SPECIFICATIONS				
WALL HEIGHT (FEET)	MASONRY WALL TYPE			
	8" CMU	4" BRICK AND 4" CMU	4" BRICK AND 8" CMU	12" CMU
2 AND BELOW	UNGROUTED	GROUT SOLID	UNGROUTED	UNGROUTED
3	UNGROUTED	GROUT SOLID	UNGROUTED	UNGROUTED
4	GROUT SOLID	GROUT SOLID w/ #4 REBAR @ 48" O.C.	GROUT SOLID	GROUT SOLID w/ #4 REBAR @ 64" O.C.
5	GROUT SOLID w/ #4 REBAR @ 36" O.C.	NOT APPLICABLE	GROUT SOLID w/ #4 REBAR @ 36" O.C.	GROUT SOLID w/ #4 REBAR @ 64" O.C.
6	GROUT SOLID w/ #4 REBAR @ 24" O.C.	NOT APPLICABLE	GROUT SOLID w/ #4 REBAR @ 24" O.C.	GROUT SOLID w/ #4 REBAR @ 64" O.C.
7 AND GREATER	ENGINEERED DESIGN BASED ON SITE CONDITIONS			

**STRUCTURAL NOTES:**

- 1) WALL HEIGHT MEASURED FROM TOP OF FOOTING TO TOP OF THE WALL.
- 2) TIE MULTIPLE WYTHES TOGETHER WITH LADDER WIRE AT 16" O.C. VERTICALLY.
- 3) CHART APPLICABLE FOR HOUSE FOUNDATION ONLY. CONSULT ENGINEER FOR DESIGN OF GARAGE FOUNDATION NOT COMMON TO HOUSE.
- 4) BACKFILL OF CLEAN #1 / #1 WASHED STONE IS ALLOWABLE.
- 5) BACKFILL OF WELL DRAINED OR SAND - GRAVEL MIXTURE SOILS (45 PSF/FT BELOW GRADE) CLASSIFIED AS GROUP 1 ACCORDING TO UNIFIED SOILS CLASSIFICATION SYSTEM IN ACCORDANCE WITH TABLE R405.1 OF THE 2018 NORTH CAROLINA RESIDENTIAL CODE ARE ALLOWABLE.
- 6) PREP SLAB PER R506.2.1 AND R506.2.2 BASE AND EXCEPTION OF 2018 NORTH CAROLINA RESIDENTIAL CODE.
- 7) MINIMUM 24" LAP SPLICE LENGTH.
- 8) LOCATE REBAR IN CENTER OF FOUNDATION WALL.
- 9) WHERE REQUIRED, FILL BLOCK SOLID WITH TYPE "S" MORTAR OR 3000 PSI GROUT. USE OF "LOW LIFT GROUTING" METHOD REQUIRED WHEN FILLING WALLS WITH GROUT AT HEIGHTS OF 5' AND GREATER.

**NOTE:**  
LOCATE REBAR 3" ABOVE BOTTOM OF FOOTING w/ MIN. 25" LAP SPLICE LENGTH.

ANCHOR SPACING AND EMBEDMENT			NOTE: THREADED ROD WITH EPOXY OR APPROVED ANCHORS SPACED AS REQUIRED TO PROVIDE EQUIVALENT ANCHORAGE TO 1/2" DIAMETER ANCHOR BOLTS MAY BE USED IN LIEU OF 1/2" ANCHOR BOLTS.
WIND ZONE	140 MPH	150 MPH	
SPACING	1'-9" O.C. w/ DBL. SILL PLATE w/ 2" x 2" x 1/8" WASHERS INSTALL MIN. (2) ANCHORS PER PLATE SECTION AND (1) ANCHOR WITHIN 12" OF CORNERS	1'-6" O.C. w/ DBL. SILL PLATE w/ 2" x 2" x 1/8" WASHERS INSTALL MIN. (2) ANCHORS PER PLATE SECTION AND (1) ANCHOR WITHIN 12" OF CORNERS	
EMBEDMENT	RODS CONTINUOUS FROM FOOTING UP THROUGH SILL PLATE w/ 1" MINIMUM CONCRETE EMBEDMENT	RODS CONTINUOUS FROM FOOTING UP THROUGH SILL PLATE w/ 1" MINIMUM CONCRETE EMBEDMENT	

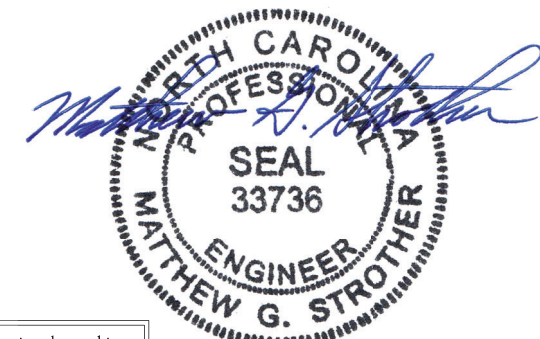

This sealed page is to be used in conjunction with a full plan set engineered by J.S. Thompson Engineering, Inc. only. Use of this individual sealed page within architectural pages or shop drawings by others is a punishable offense under N.C. Statute § 89C-23

10/25/2023

**J.S. THOMPSON ENGINEERING, INC.**  
333 EAST SIX FORKS ROAD, SUITE 180 RALEIGH, NC 27609  
PHONE: (919) 789-9919 FAX: (919) 789-9921  
N.C. LICENSE NO.: C1733

140 MPH - 150 MPH ULTIMATE DESIGN WIND SPEED  
STEM WALL FOUNDATION DETAILS

DATE: AUGUST 30, 2022  
SCALE: NTS  
DRAWN BY: JST  
ENGINEERED BY: JST

FOUNDATION DETAILS

**GENERAL WALL BRACING NOTES:**

1. WALL BRACING DESIGNED IN ACCORDANCE WITH CHAPTER 6 AND CHAPTER 45 OF THE 2018 NC RESIDENTIAL BUILDING CODE (NRC). TABLES AND FIGURES REFERENCED ARE FROM THE 2018 NRC.
2. SEE THIS SHEET FOR GENERAL DETAILS. REFER TO THE 2018 NRC FOR ADDITIONAL INFORMATION AS NEEDED.
3. SEE STRUCTURAL SHEETS FOR BRACED WALL LOCATIONS, DIMENSIONS, HOLD DOWN TYPE AND LOCATIONS, AND ANY SPECIAL NOTES OR REQUIREMENTS.
4. ALL EXTERIOR WALLS ARE TO BE SHEATHED WITH 7/16" OSB WITH BLOCKING AT ALL SHEATHING JOINTS AND 8d NAILS AT 3" O.C. ALONG EDGES AND 6" O.C. IN THE FIELD UNLESS NOTED OTHERWISE.
5. SECURE ALL EXTERIOR WALL SHEATHING PANELS TO DOUBLE TOP PLATES, BAND JOISTS, AND GIRDERS WITH (2) ROWS OF 8d NAILS STAGGERED AT 3" O.C. PANELS SHALL EXTEND 12" BEYOND CONSTRUCTION JOINTS AND SHALL OVERLAP GIRDERS AND SILL PLATES THEIR FULL DEPTH.
6. ALL EXTERIOR WALLS TO BE SHEATHED ON INSIDE FACE WITH 1/2" GYPSUM BOARD PER TABLE R702.3.5 (UNO).

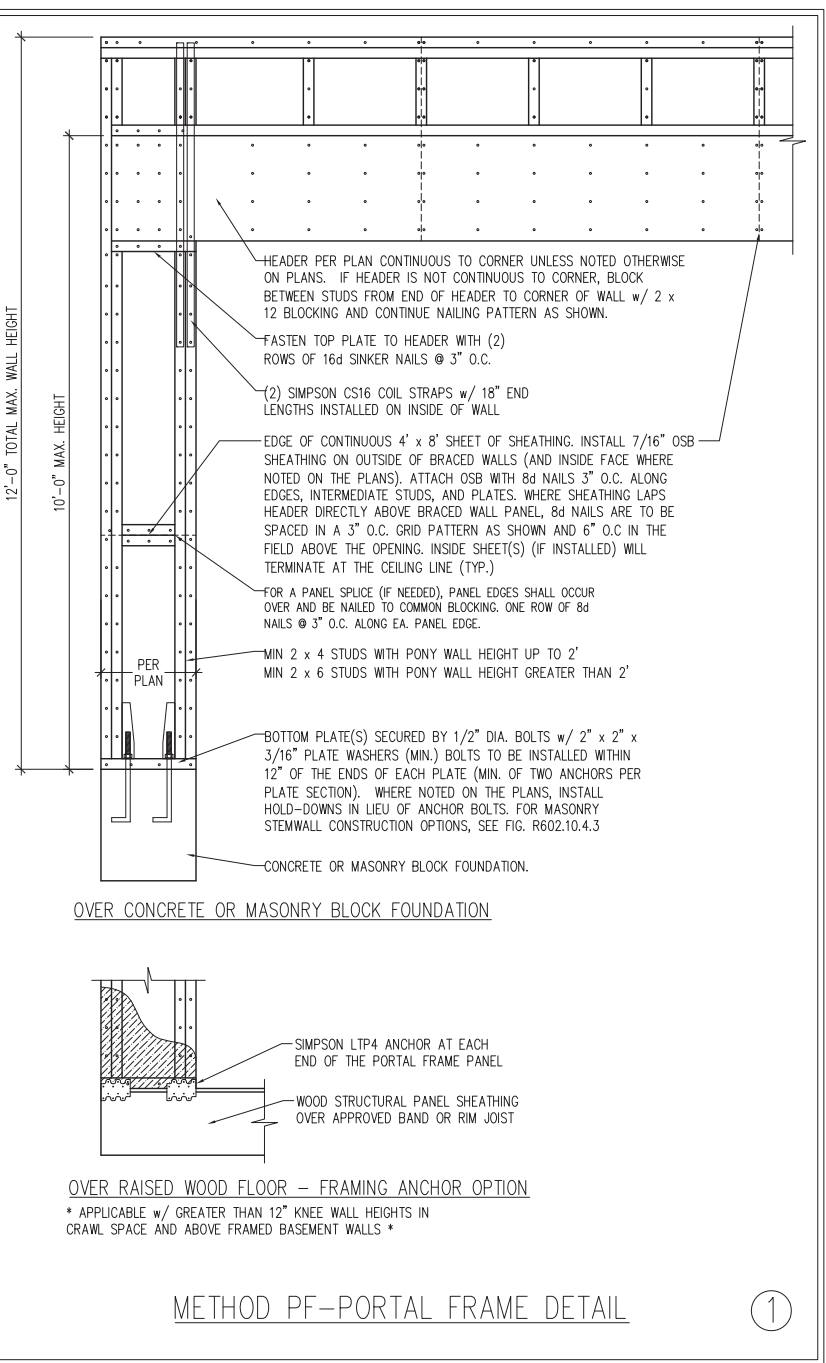
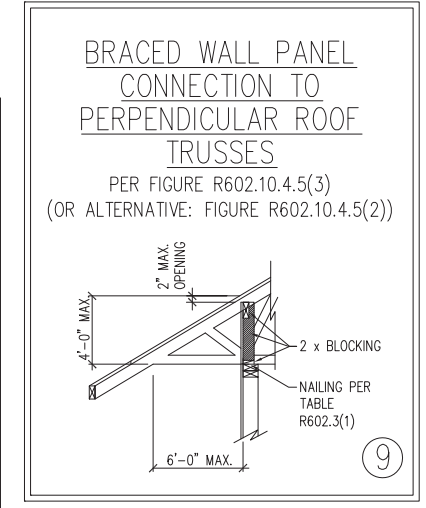
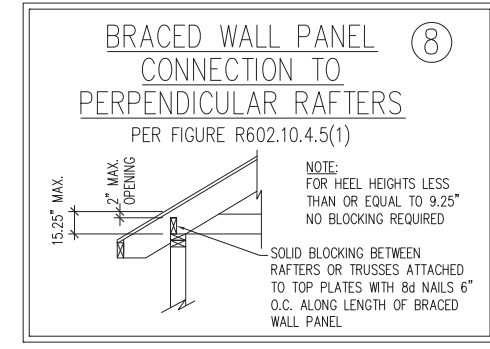
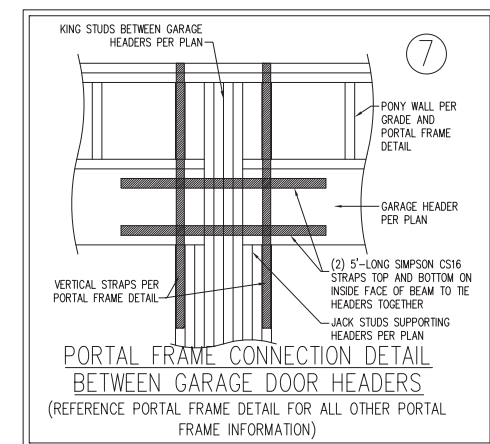
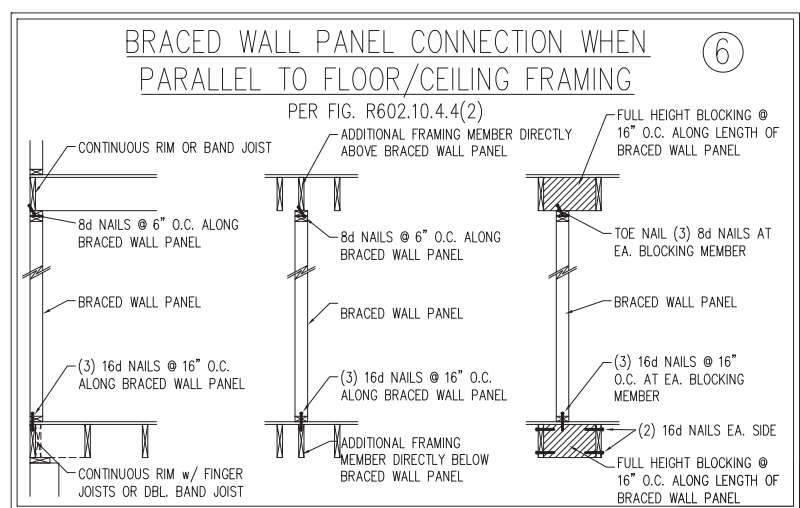
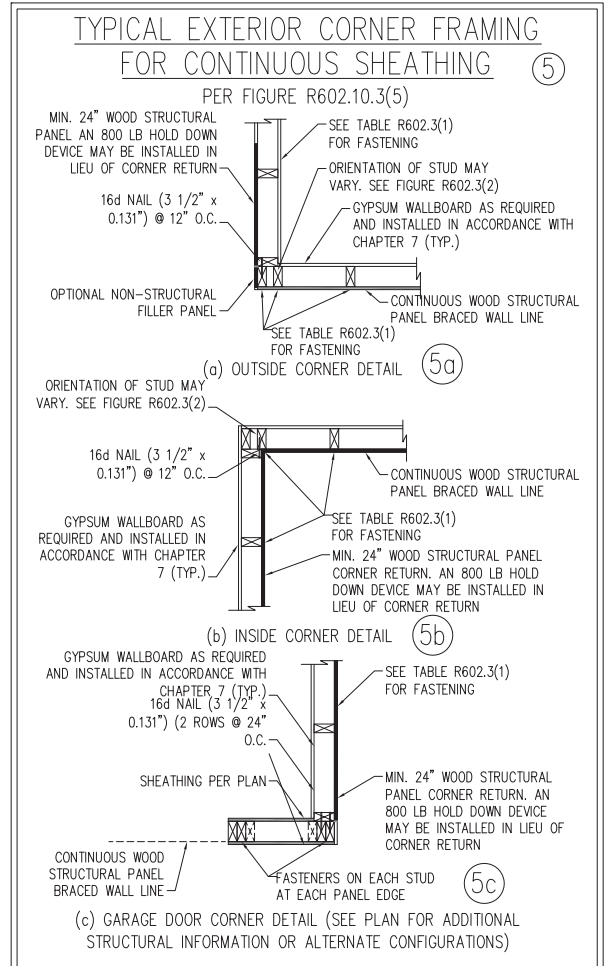
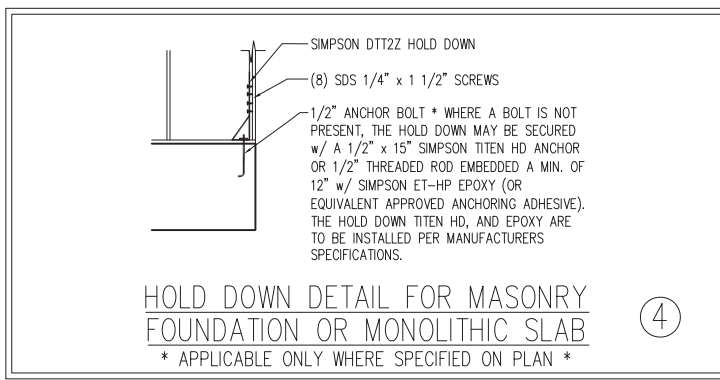
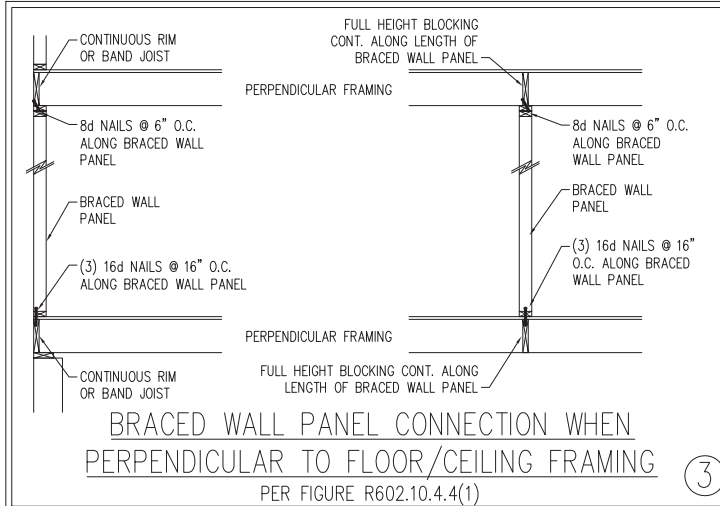
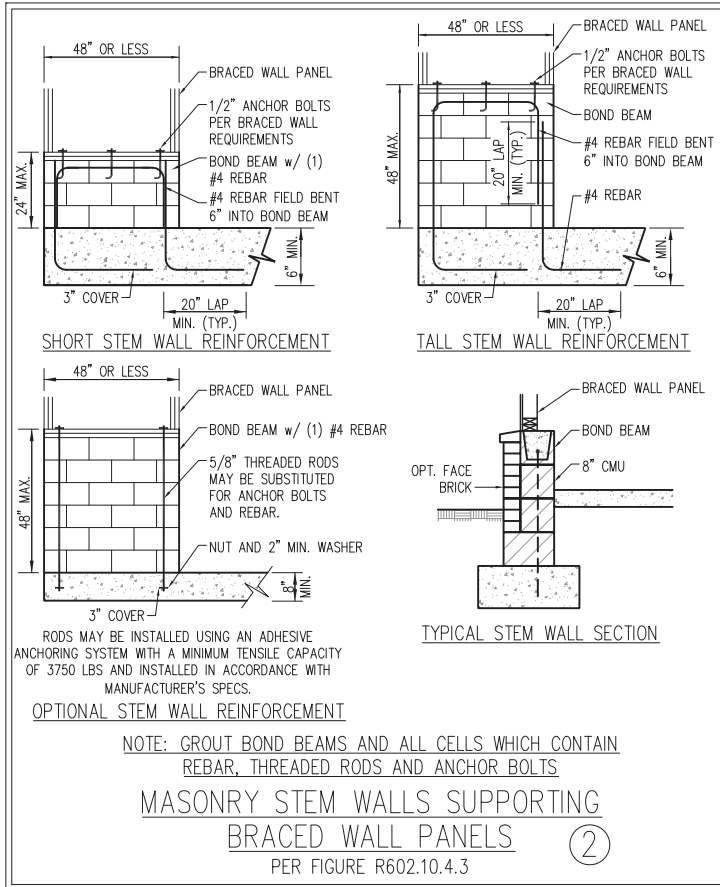

**J.S. THOMPSON ENGINEERING, INC.**  
 333 EAST SIX FORKS ROAD, SUITE 180 RALEIGH, NC 27609  
 PHONE: (919) 789-9919 FAX: (919) 789-9921  
 N.C. LICENSE NO.: C-1733

140 MPH - 150 MPH ULTIMATE DESIGN WIND SPEED  
 WALL BRACING NOTES AND DETAILS

DATE: AUGUST 30, 2022  
 SCALE: NTS  
 DRAWN BY: JST  
 ENGINEERED BY: JST

**SEAL**  
 33736  
**ENGINEER**  
**MATTHEW G. STROTHER**

10/25/2023

This sealed page is to be used in conjunction with a full plan set engineered by J.S. Thompson Engineering, Inc. only. Use of this individual sealed page within architectural pages or shop drawings by others is a punishable offense under N.C. Statute § 89C-23

SCALE NOTE:  
LARGE FORMAT PRINTS ARE TO SCALE AS NOTED.  
11" x 17" PRINTS ARE ONE HALF THE NOTED SCALE

GENERAL NOTES

- ENGINEER'S SEAL APPLIES ONLY TO STRUCTURAL COMPONENTS INCLUDING ROOF RAFTERS, HIPS, VALLEYS, RIDGES, FLOORS, WALLS, BEAMS, HEADERS, COLUMNS, CANTILEVERS, OFFSET LOAD BEARING WALLS, PIERS, GIRDER SYSTEM AND FOOTING. ENGINEER'S SEAL DOES NOT CERTIFY DIMENSIONAL ACCURACY OF ARCHITECTURAL LAYOUT INCLUDING ROOF. ENGINEER'S SEAL DOES NOT APPLY TO I-JOIST OR FLOOR/ROOF TRUSS LAYOUT DESIGN AND ACCURACY.
- ALL CONSTRUCTION SHALL CONFORM TO THE LATEST REQUIREMENTS OF THE NORTH CAROLINA RESIDENTIAL CODE (NRCR), 2018 EDITION, PLUS ALL LOCAL CODES AND REGULATIONS. THE STRUCTURAL ENGINEER IS NOT RESPONSIBLE FOR, AND WILL NOT HAVE CONTROL OF, CONSTRUCTION MEANS, METHODS, TECHNIQUES, SEQUENCES OR PROCEDURES, OR SAFETY PRECAUTIONS AND PROGRAMS IN CONNECTION WITH THE CONSTRUCTION WORK. NOR WILL THE ENGINEER BE RESPONSIBLE FOR THE CONTRACTORS FAILURE TO CARRY OUT THE CONSTRUCTION WORK IN ACCORDANCE WITH THE CONTRACT DOCUMENTS.
- STRUCTURAL DESIGN BASED ON THE PROVISIONS OF THE NRCR, 2018 EDITION (R301.4 - R301.7)

DESIGN CRITERIA:	LIVE LOAD (PSF)	DEAD LOAD (PSF)	DEFLECTION (IN)
ATTIC WITH LIMITED STORAGE	20	10	L/240 (L/360 w/ BRITTLE FINISHES)
ATTIC WITHOUT STORAGE	10	10	L/360
DECKS	40	10	L/360
EXTERIOR BALCONIES	40	10	L/360
FIRE ESCAPES	40	10	L/360
HANDRAILS/GUARDRAILS	200	10	L/360
PASSENGER VEHICLE GARAGE	50	10	L/360
ROOMS OTHER THAN SLEEPING ROOM	40	10	L/360
SLEEPING ROOMS	30	10	L/360
STAIRS	40	10	L/360
WIND LOAD	(BASED ON TABLE R301.2(4) WIND ZONE AND EXPOSURE)		
GROUND SNOW LOAD: P <sub>g</sub>	20 (PSF)		

- I-JOIST SYSTEMS DESIGNED WITH 12 PSF DEAD LOAD AND DEFLECTION (IN) OF L/480
- FLOOR TRUSS SYSTEMS DESIGNED WITH 15 PSF DEAD LOAD

- FOR 115 AND 120 MPH WIND ZONES, FOUNDATION ANCHORAGE IS TO COMPLY WITH SECTION R403.1.6 OF THE NRCR, 2018 EDITION. FOR 130 MPH, 140 MPH, AND 150 MPH WIND ZONES, FOUNDATION ANCHORAGE IS TO COMPLY WITH SECTION 4504 OF THE NRCR, 2018 EDITION.
- ENERGY EFFICIENCY COMPLIANCE AND INSULATION VALUES OF THE BUILDING TO BE IN ACCORDANCE WITH CHAPTER 11 OF THE NRCR, 2018 EDITION.

FOOTING AND FOUNDATION NOTES

- FOUNDATION DESIGN BASED ON A MINIMUM ALLOWABLE BEARING CAPACITY OF 2000 PSF. CONTACT GEOTECHNICAL ENGINEER IF BEARING CAPACITY IS NOT ACHIEVED.
- FOR ALL CONCRETE SLABS AND FOOTINGS, THE AREA WITHIN THE PERIMETER OF THE BUILDING ENVELOPE SHALL HAVE ALL VEGETATION, TOP SOIL AND FOREIGN MATERIAL REMOVED. FILL MATERIAL SHALL BE FREE OF VEGETATION AND FOREIGN MATERIAL. THE FILL SHALL BE COMPACTED TO ASSURE UNIFORM SUPPORT OF THE SLAB, AND EXCEPT WHERE APPROVED, THE FILL DEPTHS SHALL NOT EXCEED 24" FOR CLEAN SAND OR GRAVEL. A 4" THICK BASED COURSE CONSISTING OF CLEAN GRADED SAND OR GRAVEL SHALL BE PLACED. A BASE COURSE IS NOT REQUIRED WHERE A CONCRETE SLAB IS INSTALLED ON WELL-DRAINED OR SAND-GRAVEL MIXTURE SOILS CLASSIFIED AS GROUP 1, ACCORDING TO THE UNITED SOIL CLASSIFICATION SYSTEM IN ACCORDANCE WITH TABLE R405.1 OF THE NRCR, 2018 EDITION.
- PROPERLY DEWATER EXCAVATION PRIOR TO POURING CONCRETE WHEN BOTTOM OF CONCRETE SLAB IS AT OR BELOW WATER TABLE. IF APPLICABLE, 3/4" - 1" DEEP CONTROL JOINTS ARE TO BE SAWED WITHIN 4 TO 12 HOURS OF CONCRETE FINISHING AND WALL LOCATIONS HAVE BEEN MARKED. ADJUST WHERE NECESSARY.
- CONCRETE SHALL CONFORM TO SECTION R402.2 OF THE NRCR, 2018 EDITION. CONCRETE REINFORCING STEEL TO BE ASTM A615 GRADE 60. WELDED WIRE FABRIC TO BE ASTM A185. MAINTAIN A MINIMUM CONCRETE COVER AROUND REINFORCING STEEL OF 3" IN FOOTINGS AND 1 1/2" IN SLABS. FOR POURED CONCRETE WALLS, CONCRETE COVER FOR REINFORCING STEEL MEASURED FROM THE INSIDE FACE OF THE WALL SHALL NOT BE LESS THAN 3/4". CONCRETE COVER FOR REINFORCING STEEL MEASURED FROM THE OUTSIDE FACE OF THE WALL SHALL NOT BE LESS THAN 1 1/2" FOR #5 BARS OR SMALLER, AND NOT LESS THAN 2" FOR #6 BARS OR LARGER.
- MASONRY UNITS TO CONFORM TO ACE 530/ASCE 5/TMS 402. MORTAR SHALL CONFORM TO ASTM C270.
- THE UNSUPPORTED HEIGHT OF MASONRY PIERS SHALL NOT EXCEED FOUR TIMES THEIR LEAST DIMENSION FOR UNFILLED HOLLOW CONCRETE MASONRY UNITS AND TEN TIMES THEIR LEAST DIMENSION FOR SOLID OR SOLID FILLED PIERS. PERS MAY BE FILLED SOLID WITH CONCRETE OR TYPE M OR S MORTAR. PIERS AND WALLS SHALL BE CAPPED WITH 8" OF SOLID MASONRY.
- THE CENTER OF EACH OF THE PIERS SHALL BEAR IN THE MIDDLE THIRD OF ITS RESPECTIVE FOOTING. EACH GIRDER SHALL BEAR IN THE MIDDLE THIRD OF THE PIERS.
- ALL CONCRETE AND MASONRY FOUNDATION WALLS ARE TO BE CONSTRUCTED IN ACCORDANCE WITH THE PROVISIONS OF SECTION R404 OF THE NRCR, 2018 EDITION OR IN ACCORDANCE WITH ACI 318, ACI 332, NCMA TR68-A OR ACE 530/ASCE 5/TMS 402. MASONRY FOUNDATION WALLS ARE TO BE REINFORCED PER TABLE R404.1.1(1), R404.1.1(2), R404.1.1(3), OR R404.1.1(4) OF THE NRCR, 2018 EDITION. CONCRETE FOUNDATION WALLS ARE TO BE REINFORCED PER TABLE R404.1.1(5) OF THE NRCR, 2018 EDITION. STEP CONCRETE FOUNDATION WALLS TO 2 x 6 FRAMED WALLS AT 16" O.C. WHERE GRADE PERMITS (UNO).

This sealed page is to be used in conjunction with a full plan set engineered by J.S. Thompson Engineering, Inc. only. Use of this individual sealed page within architectural pages or shop drawings by others is a punishable offense under N.C. Statute § 89C-23

FRAMING NOTES

- ALL FRAMING LUMBER SHALL BE #2 SPF MINIMUM (F<sub>b</sub> = 875 PSI, F<sub>v</sub> = 375 PSI, E = 1600000 PSI) UNLESS NOTED OTHERWISE (UNO). ALL TREATED LUMBER SHALL BE #2 SYP MINIMUM (F<sub>b</sub> = 975 PSI, F<sub>v</sub> = 175 PSI, E = 1600000 PSI) UNLESS NOTED OTHERWISE (UNO).
- LAMINATED VENEER LUMBER (LVL) SHALL HAVE THE FOLLOWING MINIMUM PROPERTIES: F<sub>b</sub> = 2600 PSI, F<sub>v</sub> = 285 PSI, E = 1900000 PSI. LAMINATED STRAND LUMBER (LSL) SHALL HAVE THE FOLLOWING MINIMUM PROPERTIES: F<sub>b</sub> = 2325 PSI, F<sub>v</sub> = 310 PSI, E = 1550000 PSI. PARALLEL STRAND LUMBER (PSL) UP TO 7" DEPTH SHALL HAVE THE FOLLOWING MINIMUM PROPERTIES: F<sub>c</sub> = 2500 PSI, E = 1800000 PSI. PARALLEL STRAND LUMBER (PSL) MORE THAN 7" DEPTH SHALL HAVE THE FOLLOWING MINIMUM PROPERTIES: F<sub>c</sub> = 2900 PSI, E = 2000000 PSI. INSTALL ALL CONNECTIONS PER MANUFACTURER'S SPECIFICATIONS.
- STRUCTURAL STEEL SHALL CONFORM TO THE FOLLOWING ASTM SPECIFICATIONS
 

A. W AND WT SHAPES:	ASTM A992
B. CHANNELS AND ANGLES:	ASTM A36
C. PLATES AND BARS:	ASTM A36
D. HOLLOW STRUCTURAL SECTIONS:	ASTM A500 GRADE B
E. STEEL PIPE:	ASTM A53, GRADE B, TYPE E OR S

STEEL BEAMS SHALL BE SUPPORTED AT EACH END WITH A MINIMUM BEARING LENGTH OF 3 1/2" AND FULL FLANGE WIDTH (UNO). PROVIDE SOLID BEARING FROM BEAM SUPPORT TO FOUNDATION. BEAMS SHALL BE ATTACHED AT THE BOTTOM FLANGE TO EACH SUPPORT AS FOLLOWS (UNO):

- |                            |  |
|----------------------------|--|
| A. WOOD FRAMING            | (2) 1/2" DIA. x 4" LONG LAG SCREWS               |
| B. CONCRETE                | (2) 1/2" DIA. x 4" WEDGE ANCHORS                 |
| C. MASONRY (FULLY GROUTED) | (2) 1/2" DIA. x 4" LONG SIMPSON TITEN HD ANCHORS |
| D. STEEL PIPE COLUMN       | (4) 3/4" DIA. A325 BOLTS OR 3/16" FILLET WELD    |

LATERAL SUPPORT IS CONSIDERED ADEQUATE PROVIDING THE JOISTS ARE TOE NAILED TO THE 2x NAILER ON TOP OF THE STEEL BEAM, AND THE 2x NAILER IS SECURED TO THE TOP OF THE STEEL BEAM w/ (2) ROWS OF SELF TAPPING SCREWS @ 16" O.C. OR (2) ROWS OF 1/2" DIAMETER BOLTS @ 16" O.C. IF 1/2" BOLTS ARE USED TO FASTEN THE NAILER, THE STEEL BEAM SHALL BE FABRICATED w/ (2) ROWS OF 9/16" DIAMETER HOLES @ 16" O.C.

- SQUARES DENOTE POINT LOADS WHICH REQUIRE SOLID BLOCKING TO GIRDER OR FOUNDATION. SHADED SQUARES DENOTE POINT LOADS FROM ABOVE WHICH REQUIRE SOLID BLOCKING TO SUPPORTING MEMBER BELOW.
- ALL LOAD BEARING HEADERS TO CONFORM TO TABLE R602.7(1) AND R602.7(2) OF THE NRCR, 2018 EDITION OR BE (2) 2 x 6 WITH (1) JACK AND (1) KING STUD EACH END (UNO), WHICHEVER IS GREATER ALL HEADERS TO BE SECURED TO EACH JACK STUD WITH (4) 8d NAILS. ALL BEAMS TO BE SUPPORTED WITH (2) STUDS AT EACH BEARING POINT (UNO). INSTALL KING STUDS PER SECTION R602.7.5 OF THE NORTH CAROLINA RESIDENTIAL CODE, 2018 EDITION.
- ALL BEAMS, HEADERS, OR GIRDER TRUSSES PARALLEL TO WALL ARE TO BEAR FULLY ON (1) JACK OR (2) STUDS MINIMUM OR THE NUMBER OF JACKS OR STUDS NOTED. ALL BEAMS OR GIRDER TRUSSES PERPENDICULAR TO WALL AND SUPPORTED BY (3) STUDS OR LESS ARE TO HAVE 1 1/2" MINIMUM BEARING (UNO). ALL BEAMS OR GIRDER TRUSSES PERPENDICULAR TO WALL AND SUPPORTED BY MORE THAN (3) STUDS OR OTHER NOTED COLUMN ARE TO BEAR FULLY ON SUPPORT COLUMN FOR ENTIRE WALL DEPTH (UNO). BEAM ENDS THAT BUTT INTO ONE ANOTHER ARE TO EACH BEAR EQUAL LENGTHS (UNO).
- FLITCH BEAMS SHALL BE BOLTED TOGETHER USING 1/2" DIAMETER BOLTS (ASTM A307) WITH WASHERS PLACED AT THREADED END OF BOLT. BOLTS SHALL BE SPACED AT 24" CENTERS (MAXIMUM), AND STAGGERED AT TOP AND BOTTOM OF BEAM (2" EDGE DISTANCE), WITH (2) BOLTS LOCATED AT 6" FROM EACH END (UNO).
- ALL I-JOIST OR TRUSS LAYOUTS ARE TO BE IN COMPLIANCE WITH THE OVERALL DESIGN SPECIFIED ON THE PLANS. ALL DEVIATIONS ARE TO BE BROUGHT TO THE ATTENTION OF THE ENGINEER OF RECORD PRIOR TO INSTALLATION.
- BRACED WALL PANELS SHALL BE CONSTRUCTED ACCORDING TO THE NORTH CAROLINA RESIDENTIAL CODE 2018 EDITION WALL BRACING CRITERIA. THE AMOUNT, LENGTH, AND LOCATION OF BRACING SHALL COMPLY WITH ALL APPLICABLE TABLES IN SECTION R602.10.
- PROVIDE DOUBLE JOIST UNDER ALL WALLS PARALLEL TO FLOOR JOISTS. PROVIDE SUPPORT UNDER ALL WALLS PARALLEL TO FLOOR TRUSSES OR I-JOISTS PER MANUFACTURER'S SPECIFICATIONS. INSTALL BLOCKING BETWEEN JOISTS OR TRUSSES FOR POINT LOAD SUPPORT FOR ALL POINT LOADS ALONG OFFSET LOAD LINES.
- FOR ALL HEADERS SUPPORTING BRICK VENEER THAT ARE LESS THAN 8'-0" IN LENGTH, REST A 6" x 4" x 5/16" STEEL ANGLE WITH 6" MINIMUM EMBEDMENT AT SIDES FOR BRICK SUPPORT (U.N.O). FOR ALL HEADERS 8'-0" AND GREATER IN LENGTH, BOLT A 6" x 4" x 5/16" STEEL ANGLE TO HEADER WITH 1/2" LAG SCREWS AT 12" O.C. STAGGERED FOR BRICK SUPPORT. FOR ALL BRICK SUPPORT AT ROOF LINES, BOLT A 6" x 4" x 5/16" STEEL ANGLE TO (2) 2 x 10 BLOCKING INSTALLED w/ (4) 12d NAILS EA. PLY BETWEEN WALL STUDS WITH (2) ROWS OF 1/2" LAG SCREWS AT 12" O.C. STAGGERED AND IN ACCORDANCE WITH SECTION R703.8.2.1 OF THE NRCR, 2018 EDITION.
- FOR STICK FRAMED ROOFS: CIRCLES DENOTE (3) 2 x 4 POSTS FOR ROOF MEMBER SUPPORT. HIP SPLICES ARE TO BE SPACED A MINIMUM OF 8'-0". FASTEN MEMBERS WITH THREE ROWS OF 12d NAILS AT 16" O.C. FRAME DORMER WALLS ON TOP OF DOUBLE OR TRIPLE RAFTERS AS SHOWN (UNO).
- FOR TRUSSED ROOFS: FRAME DORMER WALLS ON TOP OF 2 x 4 LADDER FRAMING AT 24" O.C. BETWEEN ADJACENT ROOF TRUSSES. STICK FRAME OVER-FRAMED ROOF SECTIONS WITH 2 x 8 RIDGES, 2 x 6 RAFTERS AT 16" O.C. AND FLAT 2 x 10 VALLEYS (UNO).
- ALL 4 x 4 AND 6 x 6 POSTS TO BE INSTALLED WITH 700 LB CAPACITY UPLIFT CONNECTORS TOP AND BOTTOM (UNO). POSTS MAY BE SECURED USING ONE SIMPSON H6 OR LTS12 UPLIFT CONNECTOR FASTENED TO THE BAND AT THE BOTTOM AND THE BEAM AT THE TOP OF EACH POST. ONE 16" SECTION OF SIMPSON CS16 COIL STRAPPING WITH (8) 8d HDG NAILS AT EACH END MAY BE USED IN LIEU OF EACH TWIST STRAP IF DESIRED. FOR MASONRY OR CONCRETE FOUNDATION USE SIMPSON POST BASE.

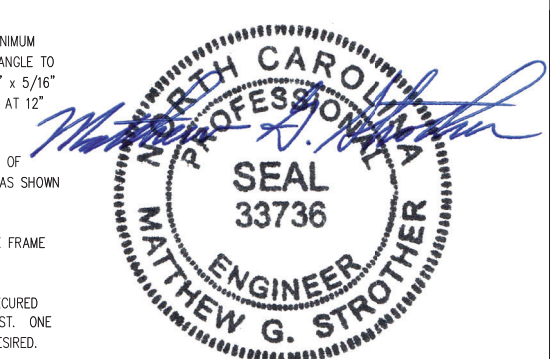

10/25/2023

**J.S. THOMPSON**  
**ENGINEERING, INC**  
333 EAST SIX FORKS ROAD, SUITE 180 RALEIGH, NC 27609  
PHONE: (919) 789-9919 FAX: (919) 789-9921  
N.C. LICENSE NO.: CJ133

STANDARD STRUCTURAL NOTES

DATE: AUGUST 30, 2022  
DRAWN BY: JST  
ENGINEERED BY: JST

STRUCTURAL NOTES

**PLUMBING NOTES**

PLUMBERS MUST KEEP PLUMBING IN GRADE BEAM AREAS TO A BARE MINIMUM IN ORDER TO ENSURE PROPER STRUCTURAL INTEGRITY OF THE BUILDING. FAILURE TO DO WILL RESULT IN REINSTALLATION OF PLUMBING IN THESE AREAS.

REQUIRED PLUMBING VENTS MUST ALSO BE INSTALLED AND ROUTED TO VENT ON THE REAR SIDE OF THE HOUSE IN ORDER TO PREVENT AN UNSIGHTLY FRONT ELEVATION.

\*DIMENSIONS ARE TO OUTSIDE FACE OF STUDS AND DO NOT ACCOUNT FOR BRICK VENEER\*

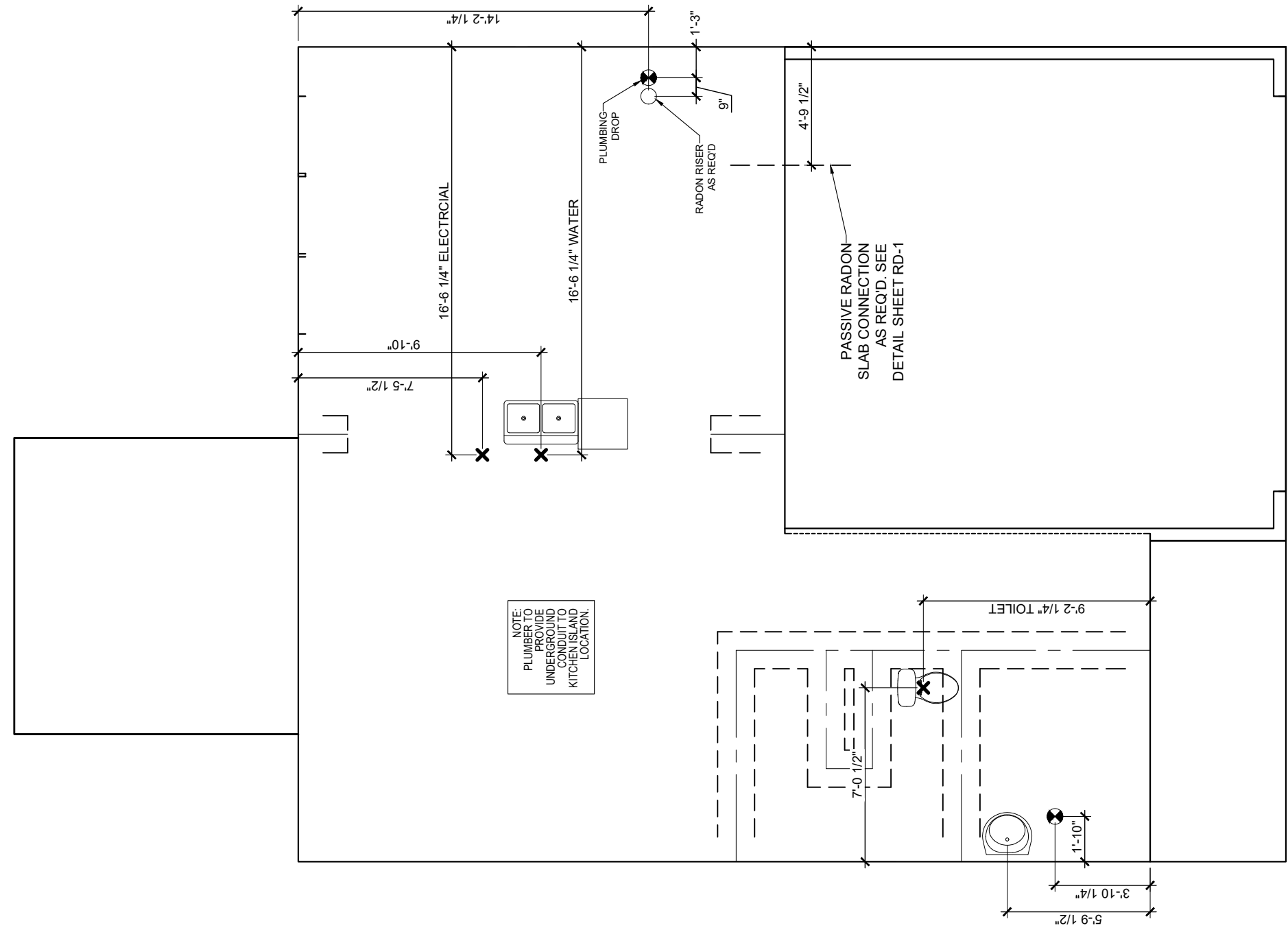

UNDER SLAB PLUMBING PLAN



**McCLEAN II B**

DRAWN JES/TW  
 CHECKED \_\_\_\_\_  
 DATE 08/10/22  
 PROJ. NO. \_\_\_\_\_  
 PRINTED \_\_\_\_\_

REVISION NO.	REVISION DATE	DESCRIPTION
4	05/24/23	TUBS/SHOWERS
5 JSC	01/31/24	FIREPLACE
6 (ies)	03/4/24	Lighting / Vanity update
7 JSC	05/09/24	FOOTINGS @ PWDR. ROOM

\*THESE PLANS, DRAWINGS AND/OR DOCUMENTS AND THE INFORMATION CONTAINED THEREIN ARE CONFIDENTIAL AND PROPRIETARY TO GREAT SOUTHERN HOMES AND ARE "TRADE SECRETS" AS DEFINED BY S.C. CODE ANN. §39-8-20 (5)(a)(b).\*

GREATSOUTHERN HOMES CAN NOT GUARANTEE AGAINST ERRORS AND OMISSIONS WITHIN THESE PLANS. THE CONTRACTOR MUST VERIFY ALL DIMENSIONS AND MAY ADJUST THE CONSTRUCTION ACCORDINGLY TO STANDARDS

**SQUARE FOOTAGE INFORMATION**

FIRST FLOOR.....	847
SECOND FLOOR.....	1161
GARAGE.....	402
FRONT PORCH.....	72
PATIO.....	138
TOTAL HEATED.....	2008
OPT SUNROOM.....	+138
OPT SUNROOM PATIO.....	115

**GARAGE RIGHT**

DRAWING TITLE  
 PLUMBING PLAN  
 DRAWING NO.  
 P-1

COPYRIGHT © 2024

\*DIMENSIONS ARE TO OUTSIDE FACE OF STUDS AND DO NOT ACCOUNT FOR BRICK VENEER\*

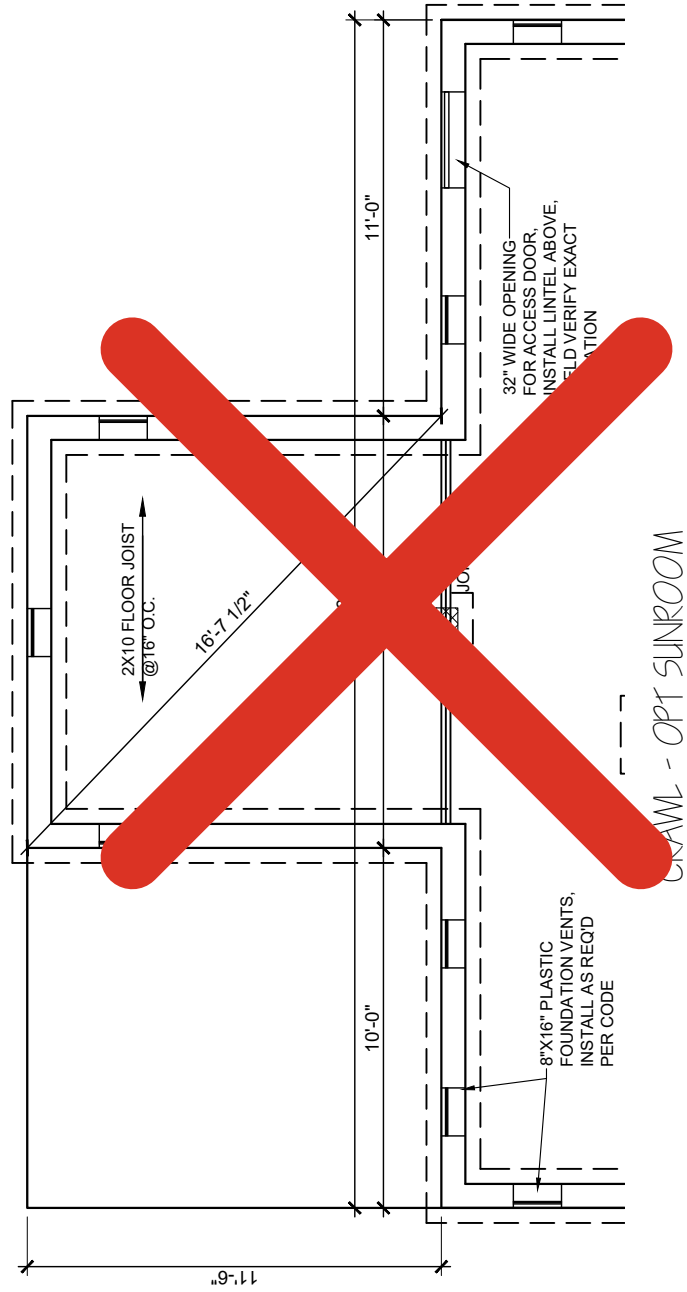

CRAWL - OPT SUNROOM

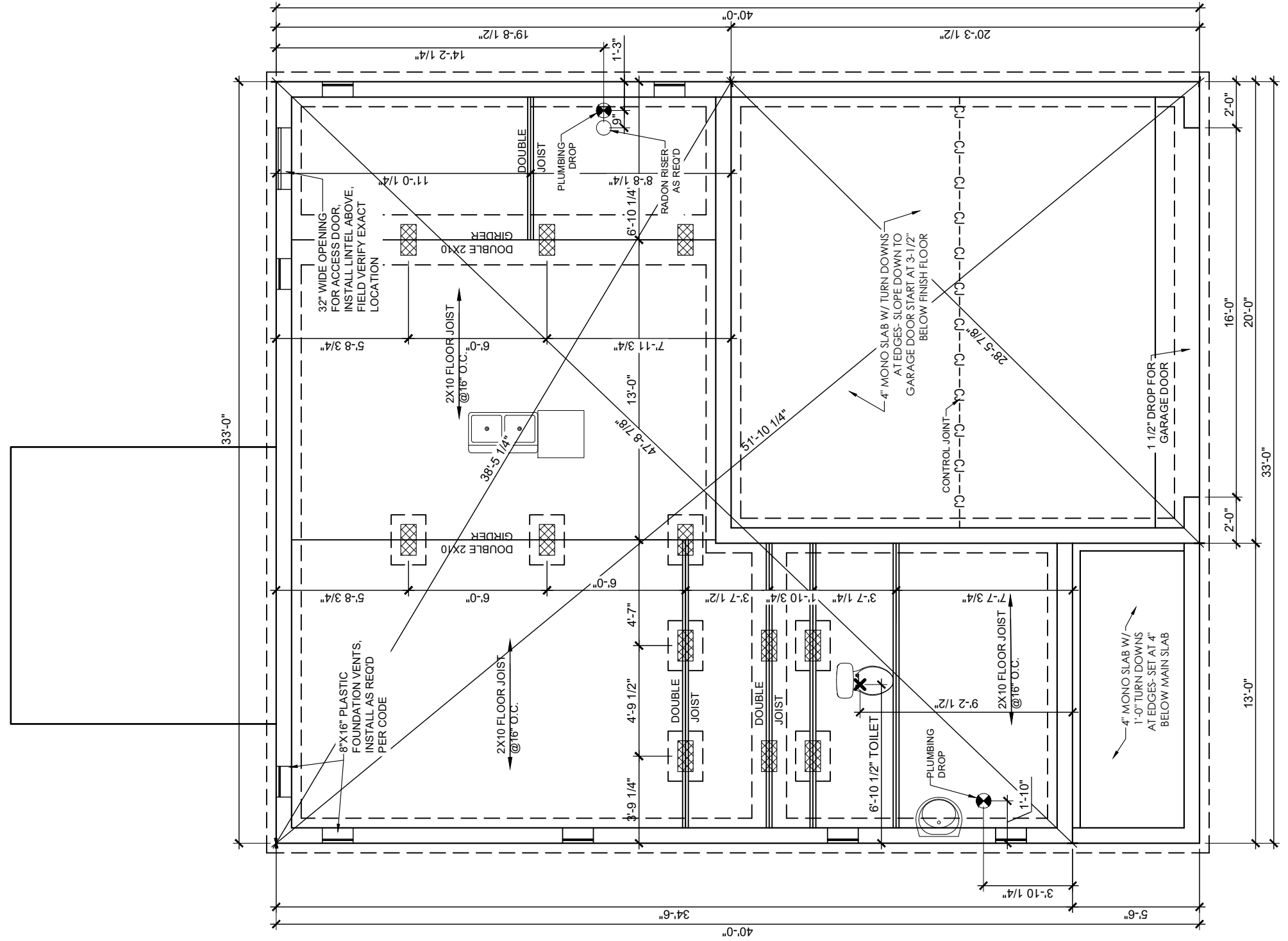

CRAWL SPACE FOUNDATION PLAN



# McCLEAN II B

DRAWN JES/TW  
 CHECKED             
 DATE 08/10/22  
 PROJ. NO.             
 PRINTED           

REVISION NO.	REVISION DATE	DESCRIPTION
4	05/24/23	TUBS/SHOWERS
5 JSC	01/31/24	FIREPLACE
6 (ies)	03/4/24	Lighting / Vanity update
7 JSC	05/09/24	FOOTINGS @ PWDR. ROOM

THESE PLANS, DRAWINGS AND/OR DOCUMENTS AND THE INFORMATION CONTAINED THEREIN ARE CONFIDENTIAL AND PROPRIETARY TO GREAT SOUTHERN HOMES AND ARE "TRADE SECRETS" AS DEFINED BY S.C. CODE ANN. §39-8-20 (5)(a)(b).\*

GREATSOUTHERN HOMES CAN NOT GUARANTEE AGAINST ERRORS AND OMISSIONS WITHIN THESE PLANS. THE CONTRACTOR MUST VERIFY ALL DIMENSIONS AND MAY ADJUST THE CONSTRUCTION ACCORDINGLY TO STANDARDS

SQUARE FOOTAGE INFORMATION	
FIRST FLOOR.....	847
SECOND FLOOR.....	1161
GARAGE.....	402
FRONT PORCH.....	72
PATIO.....	138
TOTAL HEATED.....	2008
OPT SUNROOM.....	+138
OPT SUNROOM PATIO.....	115

## GARAGE RIGHT

DRAWING TITLE  
RAISED SLAB PLAN  
 DRAWING NO.  
F-3



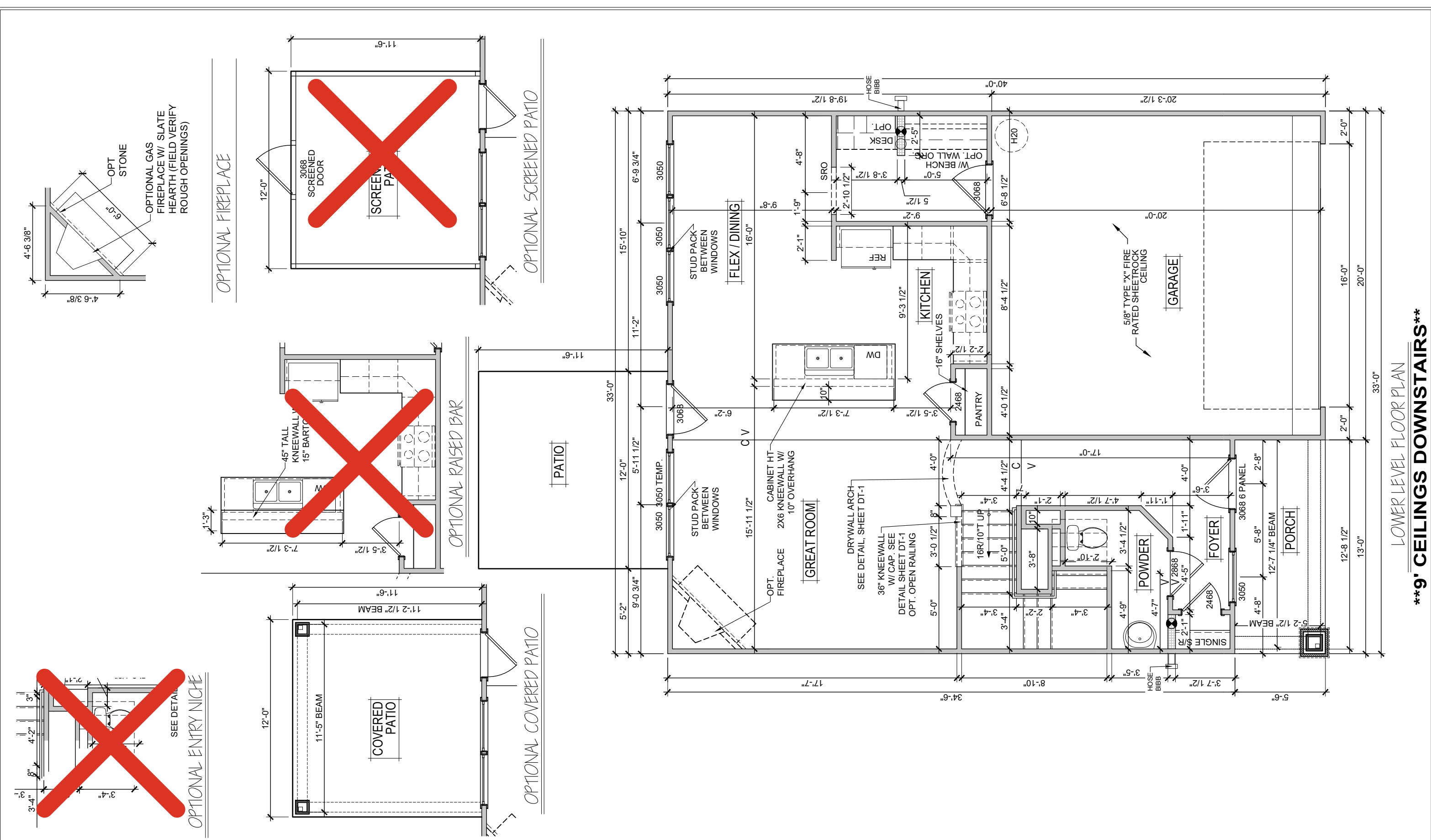

# McCLEAN II B

DRAWN	JES/TW
CHECKED	
DATE	08/10/22
PROJ. NO.	
PRINTED	

REVISION NO.	REVISION DATE	DESCRIPTION
4	05/24/23	TUBS/SHOWERS
5 JSC	01/31/24	FIREPLACE
6 (jes)	03/4/24	Lighting / Vanity update
7 JSC	05/09/24	FOOTINGS @ PWDR. ROOM

"THESE PLANS, DRAWINGS AND/OR DOCUMENTS AND THE INFORMATION CONTAINED THEREIN ARE CONFIDENTIAL AND PROPRIETARY TO GREAT SOUTHERN HOMES AND ARE "TRADE SECRETS" AS DEFINED BY S.C. CODE ANN. §39-8-20 (5)(a)(b)." COPYRIGHT © 2024

GREATSOUTHERN HOMES CAN NOT GUARANTEE AGAINST ERRORS AND OMISSIONS WITHIN THESE PLANS. THE CONTRACTOR MUST VERIFY ALL DIMENSIONS AND MAY ADJUST THE CONSTRUCTION ACCORDINGLY TO STANDARDS

SQUARE FOOTAGE INFORMATION	
FIRST FLOOR	847
SECOND FLOOR	1161
GARAGE	402
FRONT PORCH	72
PATIO	138
TOTAL HEATED	2008
OPT SUNROOM	+138
OPT SUNROOM PATIO	115

**GARAGE RIGHT**

DRAWING TITLE	FIRST FLOOR
DRAWING NO.	A-1

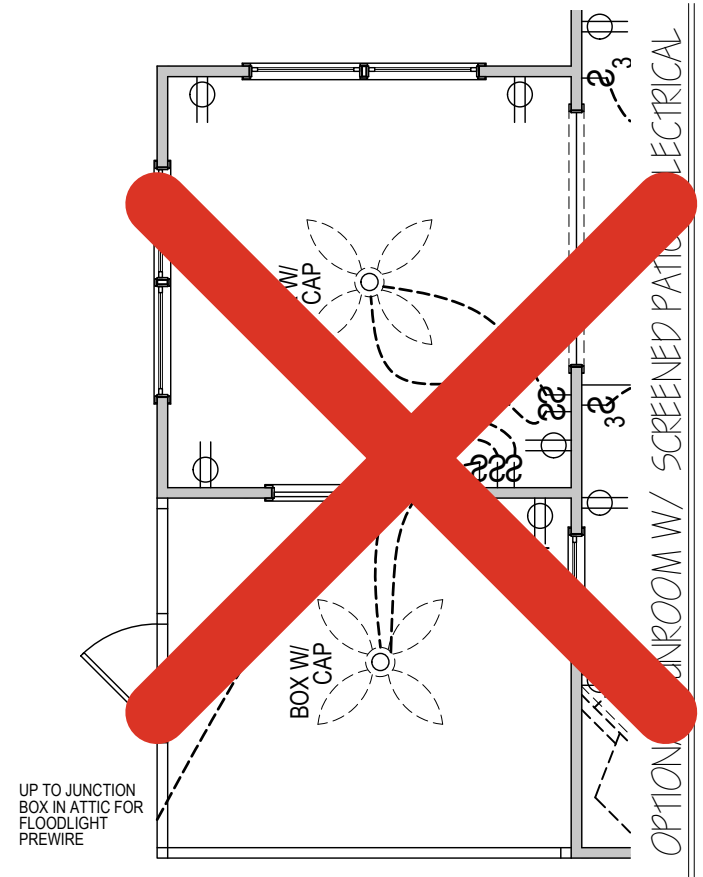
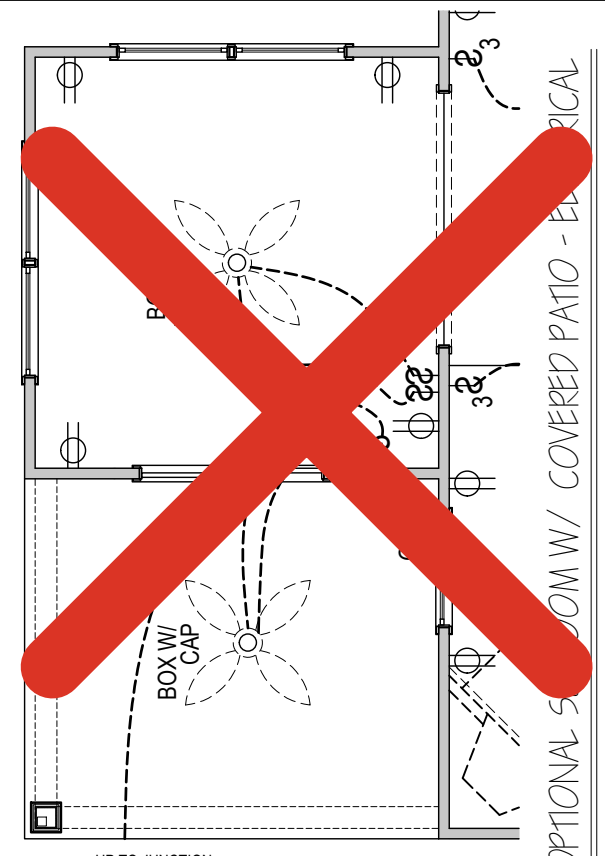
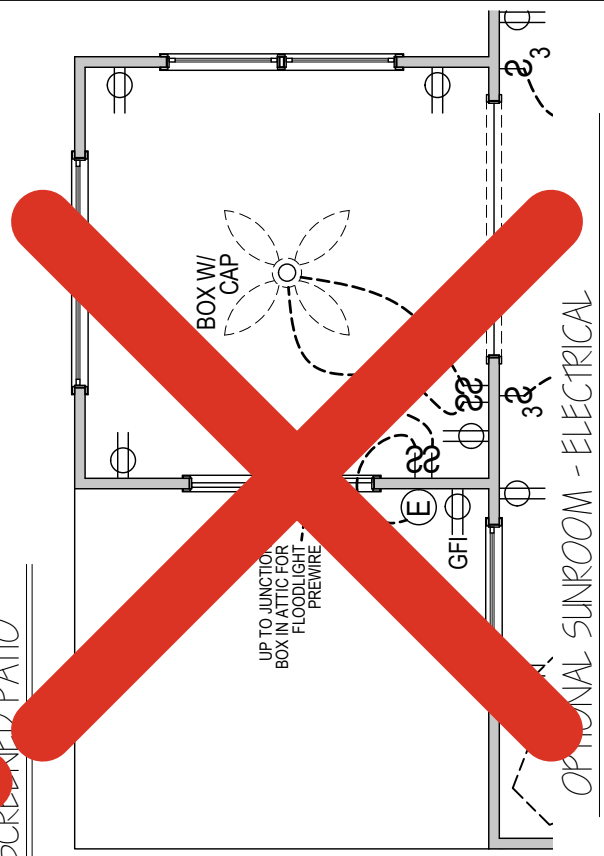
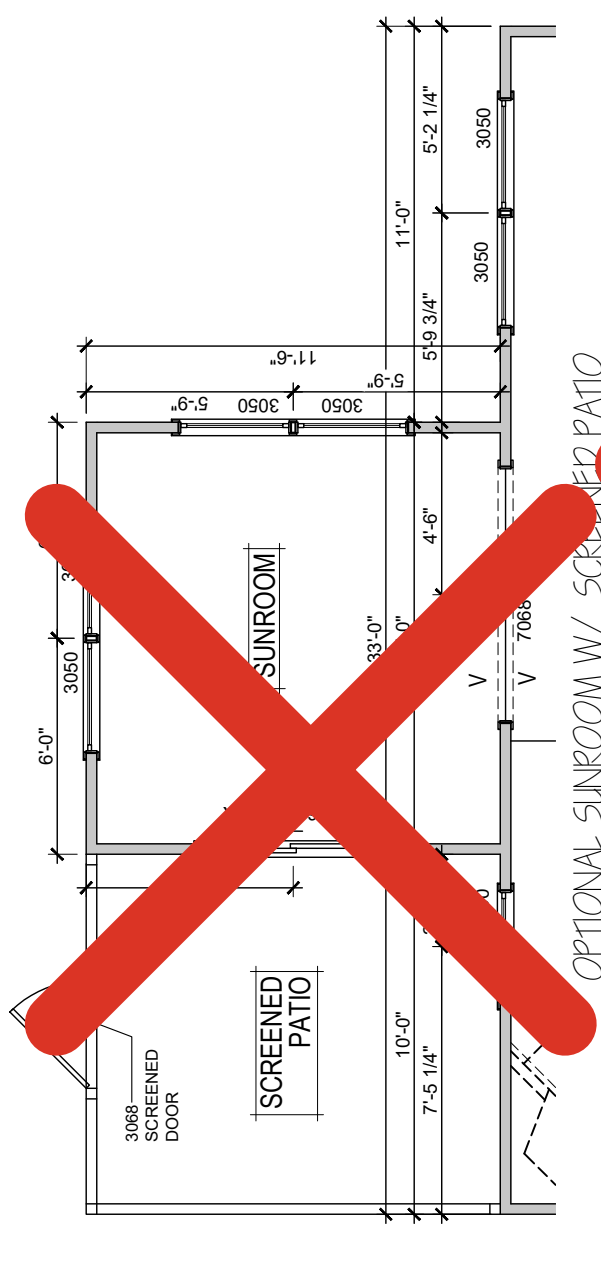
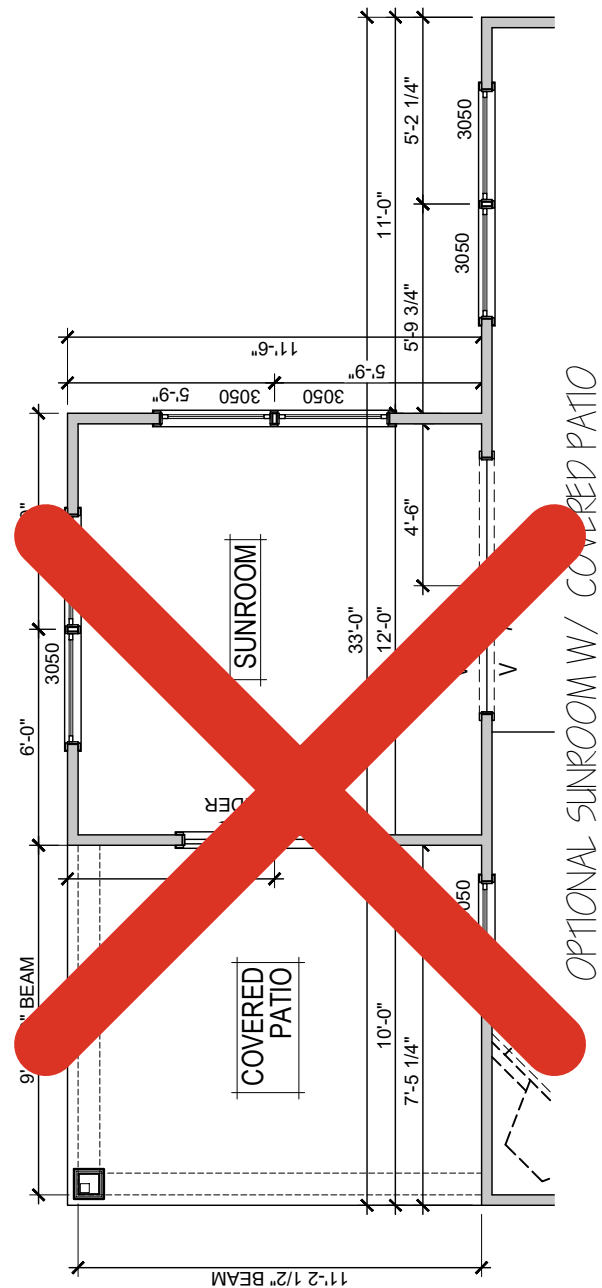
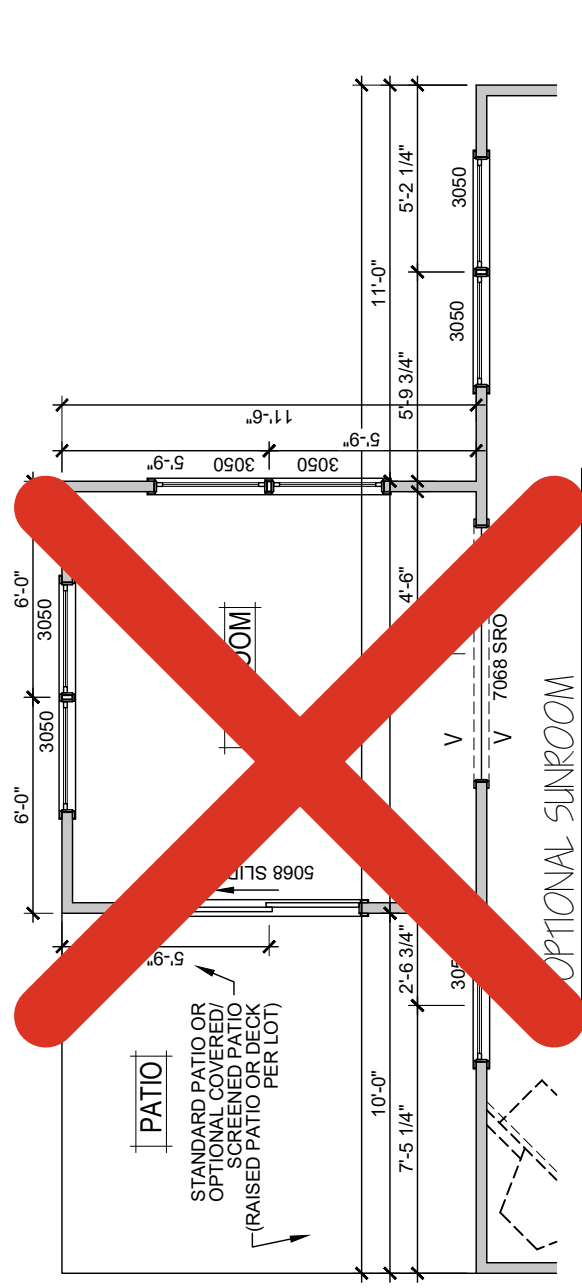

# McCLEAN II B

DRAWN	JES/TW	REVISION NO.	4	REVISION DATE	05/24/23	DESCRIPTION	TUBS/SHOWERS
CHECKED		5 JSC	01/31/24			FIREPLACE	
DATE	08/10/22	6 (ies)	03/4/24			Lighting / Vanity update	
PROJ. NO.		7 JSC	05/09/24			FOOTINGS @ PWDR. ROOM	
PRINTED							

"THESE PLANS, DRAWINGS AND/OR DOCUMENTS AND THE INFORMATION CONTAINED THEREIN ARE CONFIDENTIAL AND PROPRIETARY TO GREAT SOUTHERN HOMES AND ARE "TRADE SECRETS" AS DEFINED BY S.C. CODE ANN. §39-8-20 (5)(a)(b)." COPYRIGHT © 2024

GREATSOUTHERN HOMES CAN NOT GUARANTEE AGAINST ERRORS AND OMISSIONS WITHIN THESE PLANS. THE CONTRACTOR MUST VERIFY ALL DIMENSIONS AND MAY ADJUST THE CONSTRUCTION ACCORDINGLY TO STANDARDS

SQUARE FOOTAGE INFORMATION	
FIRST FLOOR.....	847
SECOND FLOOR.....	1161
GARAGE.....	402
FRONT PORCH.....	72
PATIO.....	138
TOTAL HEATED.....	2008
OPT SUNROOM.....	+138
OPT SUNROOM PATIO.....	115

**GARAGE RIGHT**

DRAWING TITLE  
OPT SUNROOM  
DRAWING NO.  
A-1b

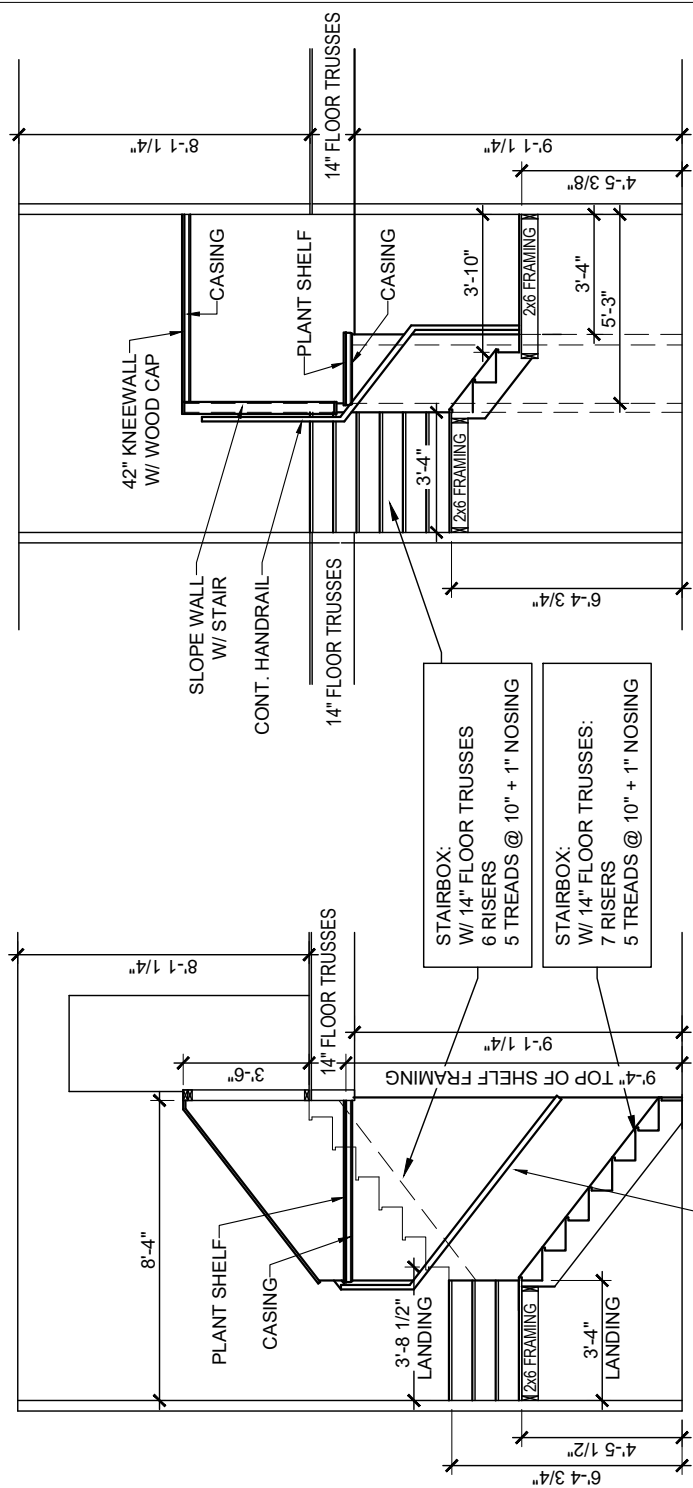

STAIR SECTION

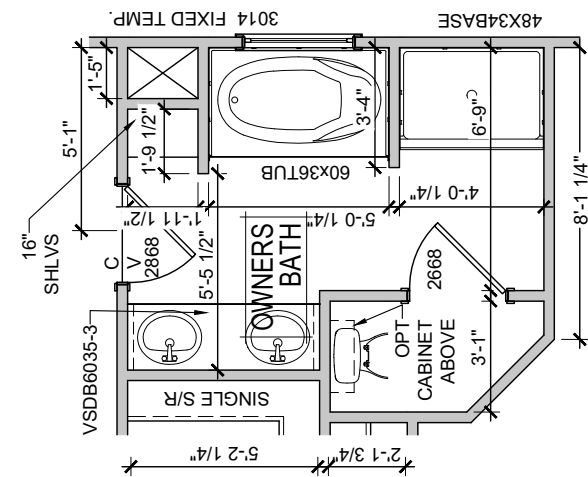

TILE SHOWER OPTION

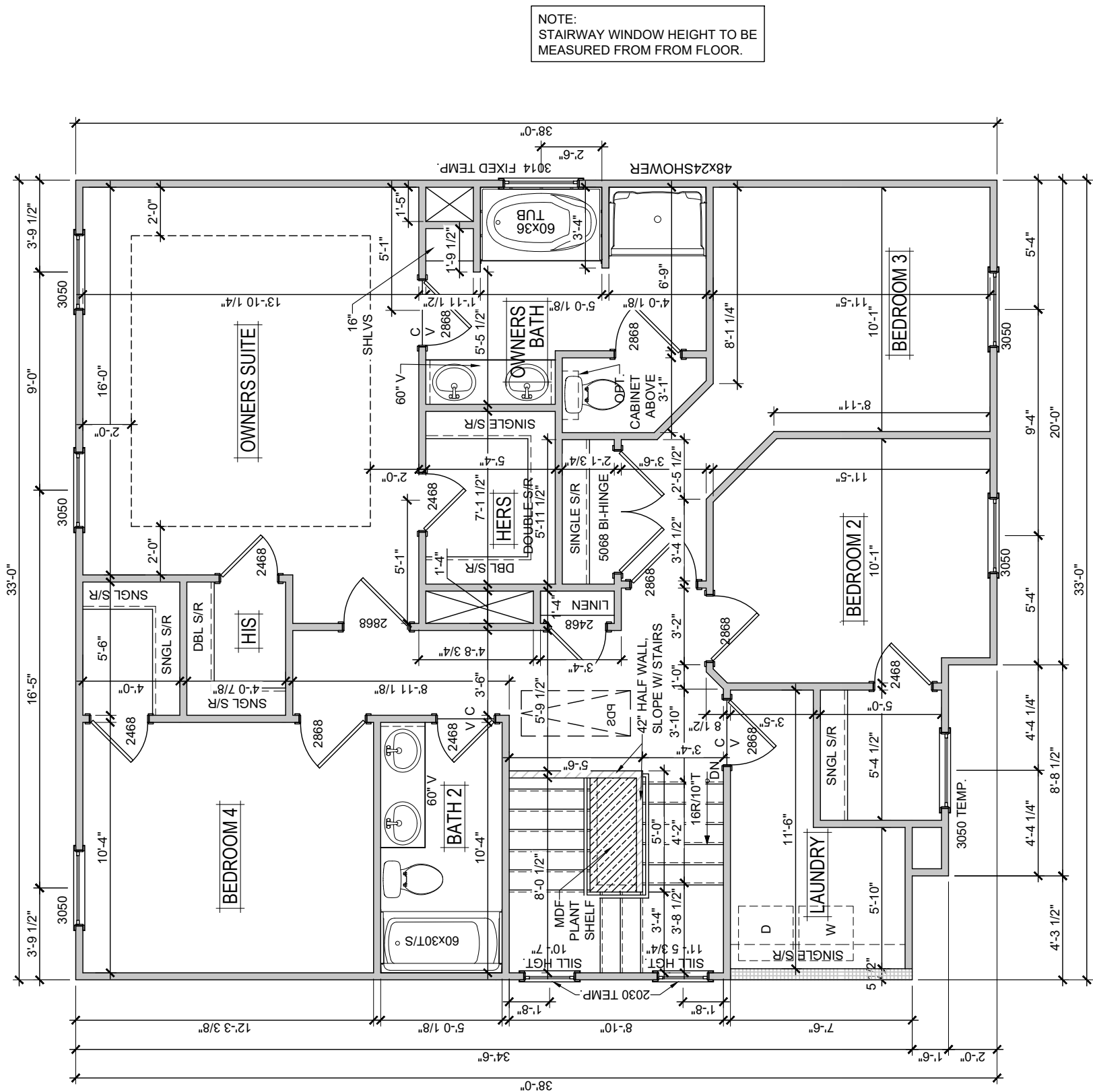

NOTE:  
STAIRWAY WINDOW HEIGHT TO BE  
MEASURED FROM FROM FLOOR.

UPPER LEVEL FLOOR PLAN  
\*\*8' CEILINGS UPSTAIRS\*\*



**McCLEAN II B**

DRAWN	JES/TW
CHECKED	
DATE	08/10/22
PROJ. NO.	
PRINTED	

REVISION NO.	REVISION DATE	DESCRIPTION
4	05/24/23	TUBS/SHOWERS
5 JSC	01/31/24	FIREPLACE
6 (jes)	03/4/24	Lighting / Vanity update
7 JSC	05/09/24	FOOTINGS @ PWDR. ROOM

"THESE PLANS, DRAWINGS AND/OR DOCUMENTS AND THE INFORMATION CONTAINED THEREIN ARE CONFIDENTIAL AND PROPRIETARY TO GREAT SOUTHERN HOMES AND ARE "TRADE SECRETS" AS DEFINED BY S.C. CODE ANN. §39-8-20 (5)(a)(b)." COPYRIGHT © 2024

GREATSOUTHERN HOMES CAN NOT GUARANTEE AGAINST ERRORS AND OMISSIONS WITHIN THESE PLANS. THE CONTRACTOR MUST VERIFY ALL DIMENSIONS AND MAY ADJUST THE CONSTRUCTION ACCORDINGLY TO STANDARDS

SQUARE FOOTAGE INFORMATION

FIRST FLOOR	847
SECOND FLOOR	1161
GARAGE	402
FRONT PORCH	72
PATIO	138
TOTAL HEATED	2008
OPT SUNROOM	+138
OPT SUNROOM PATIO	115

**GARAGE RIGHT**

DRAWING TITLE  
SECOND FLOOR  
DRAWING NO.  
A-2

**FRAMING NOTES**  
 FRAMERS TO REFER TO TRUSS PACKAGES FOR TRUSS LAYOUTS AND DIMENSIONS. THE PLANS SHOWN HERE ARE FOR REFERENCE ONLY. PLEASE CONTACT DESIGNER WITH ANY CONFLICTS.

**TRUSS MANUFACTURER**  
 PLEASE ENSURE ALL CHASE LOCATIONS, ATTIC ACCESS, ATTIC PLATFORMS, AND PLUMBING DROP LOCATIONS ARE ACCOUNTED FOR AND NOTED ON ALL CORRESPONDING SHEETS OF YOUR TRUSS PACKAGES. PLEASE CONTACT DESIGNER WITH ANY CONFLICTS.

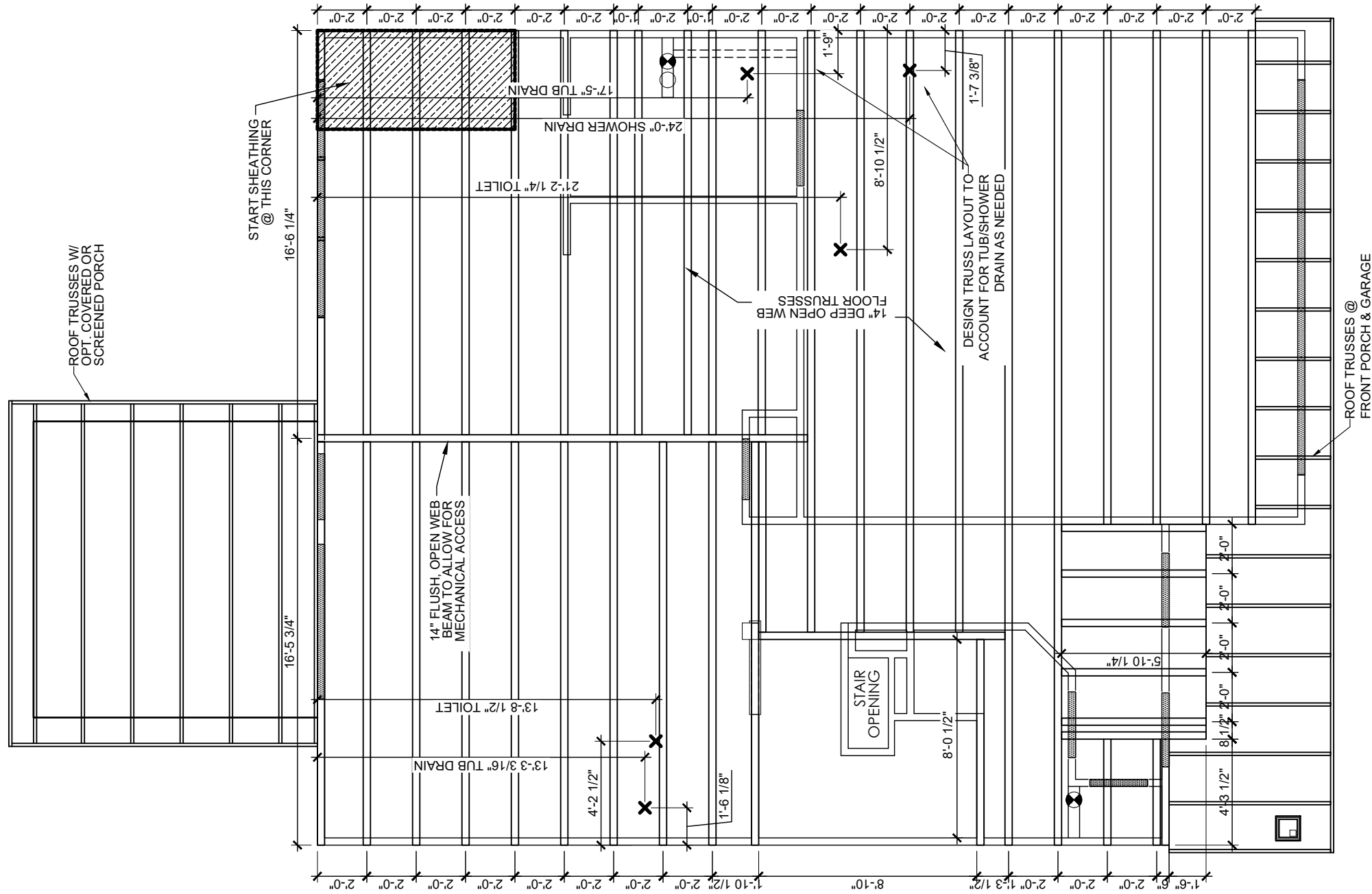

SECOND FLOOR FRAMING PLAN



**McCLEAN II B**

DRAWN JES/TW  
 CHECKED \_\_\_\_\_  
 DATE 08/10/22  
 PROJ. NO. \_\_\_\_\_  
 PRINTED \_\_\_\_\_

REVISION NO.	REVISION DATE	DESCRIPTION
4	05/24/23	TUBS/SHOWERS
5 JSC	01/31/24	FIREPLACE
6 (jes)	03/4/24	Lighting / Vanity update
7 JSC	05/09/24	FOOTINGS @ PWDR. ROOM

"THESE PLANS, DRAWINGS AND/OR DOCUMENTS AND THE INFORMATION CONTAINED THEREIN ARE CONFIDENTIAL AND PROPRIETARY TO GREAT SOUTHERN HOMES AND ARE "TRADE SECRETS" AS DEFINED BY S.C. CODE ANN. §39-8-20 (5)(a)(b)." COPYRIGHT © 2024

GREATSOUTHERN HOMES CAN NOT GUARANTEE AGAINST ERRORS AND OMISSIONS WITHIN THESE PLANS. THE CONTRACTOR MUST VERIFY ALL DIMENSIONS AND MAY ADJUST THE CONSTRUCTION ACCORDINGLY TO STANDARDS

**SQUARE FOOTAGE INFORMATION**

FIRST FLOOR.....	847
SECOND FLOOR.....	1161
GARAGE.....	402
FRONT PORCH.....	72
PATIO.....	138
TOTAL HEATED.....	2008
OPT SUNROOM.....	+138
OPT SUNROOM PATIO.....	115

**GARAGE RIGHT**

DRAWING TITLE  
 FLOOR FRAMING  
 DRAWING NO.  
 A-3



# McCLEAN II B

DRAWN JES/TW  
 CHECKED \_\_\_\_\_  
 DATE 08/10/22  
 PROJ. NO. \_\_\_\_\_  
 PRINTED \_\_\_\_\_

REVISION NO.	REVISION DATE	DESCRIPTION
4	05/24/23	TUBS/SHOWERS
5 JSC	01/31/24	FIREPLACE
6 (ies)	03/4/24	Lighting / Vanity update
7 JSC	05/09/24	FOOTINGS @ PWDR. ROOM

"THESE PLANS, DRAWINGS AND/OR DOCUMENTS AND THE INFORMATION CONTAINED THEREIN ARE CONFIDENTIAL AND PROPRIETARY TO GREAT SOUTHERN HOMES AND ARE "TRADE SECRETS" AS DEFINED BY S.C. CODE ANN. §39-8-20 (5)(a)(b)." COPYRIGHT © 2024

GREATSOUTHERN HOMES CAN NOT GUARANTEE AGAINST ERRORS AND OMISSIONS WITHIN THESE PLANS. THE CONTRACTOR MUST VERIFY ALL DIMENSIONS AND MAY ADJUST THE CONSTRUCTION ACCORDINGLY TO STANDARDS

SQUARE FOOTAGE INFORMATION

FIRST FLOOR.....	847
SECOND FLOOR.....	1161
GARAGE.....	402
FRONT PORCH.....	72
PATIO.....	138
TOTAL HEATED.....	2008
OPT SUNROOM.....	+138
OPT SUNROOM PATIO.....	115

## GARAGE RIGHT

DRAWING TITLE  
ROOF FRAMING

DRAWING NO.  
A-4

NOTE:  
 \*\*\*HEEL TRUSSES 6" WITH FULL BRICK VENEER CONDITIONS

FRAMING NOTES  
 FRAMERS TO REFER TO TRUSS PACKAGES FOR TRUSS LAYOUTS AND DIMENSIONS. THE PLANS SHOWN HERE ARE FOR REFERENCE ONLY. PLEASE CONTACT DESIGNER WITH ANY CONFLICTS.

TRUSS MANUFACTURER  
 PLEASE ENSURE ALL CHASE LOCATIONS, ATTIC ACCESS, ATTIC PLATFORMS, AND PLUMBING DROP LOCATIONS ARE ACCOUNTED FOR AND NOTED ON ALL CORRESPONDING SHEETS OF YOUR TRUSS PACKAGES. PLEASE CONTACT DESIGNER WITH ANY CONFLICTS.

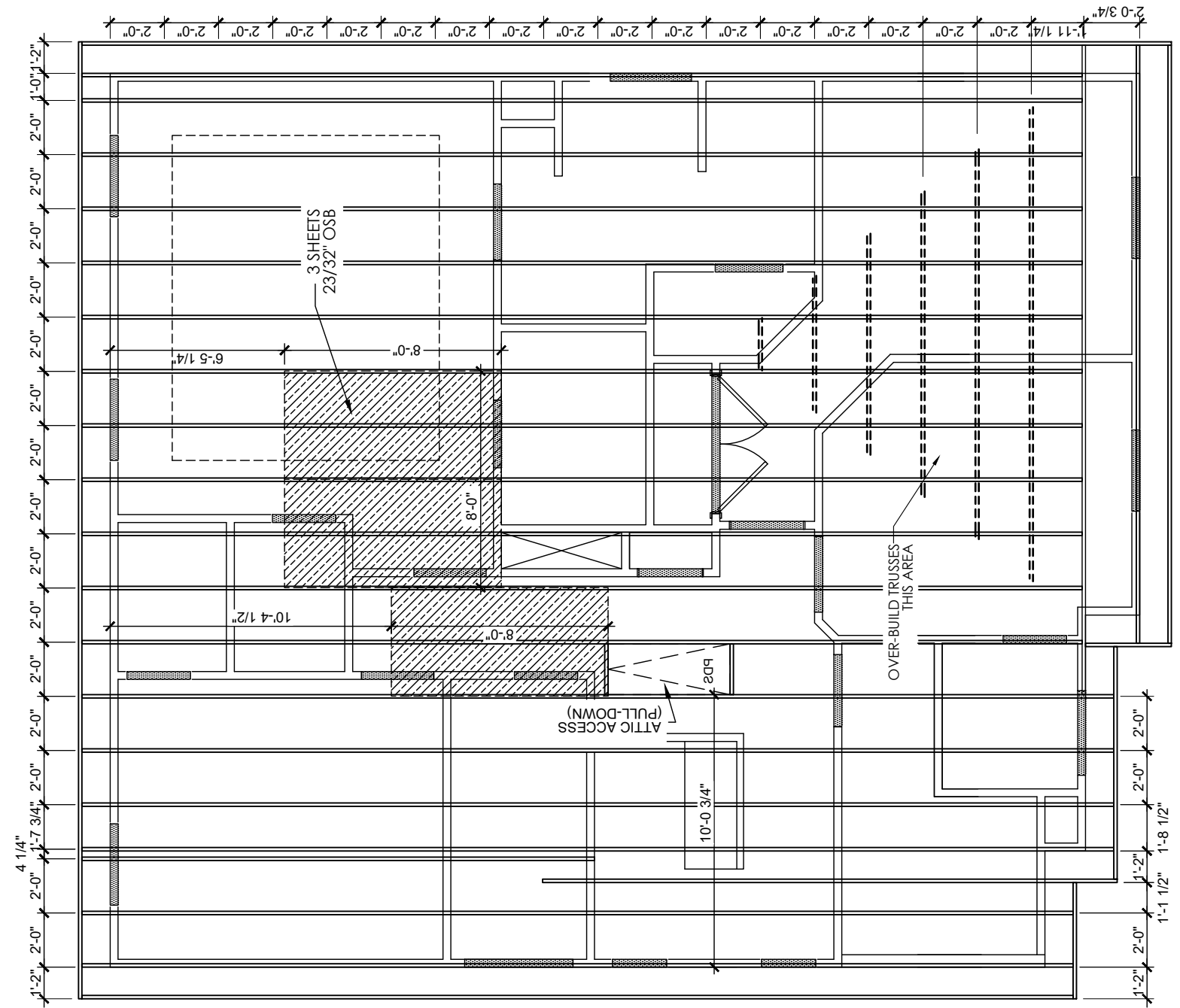

ROOF FRAMING PLAN

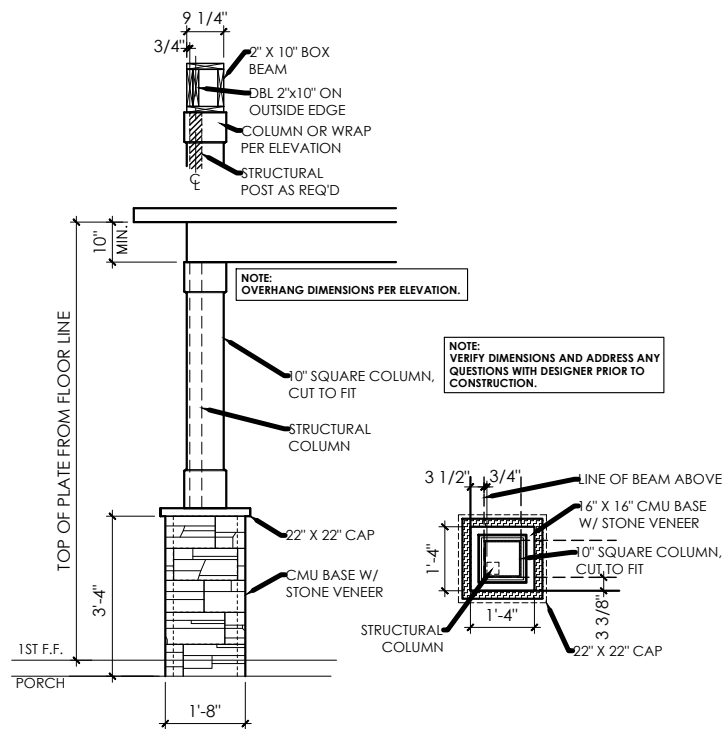

PORCH COLUMN DETAIL

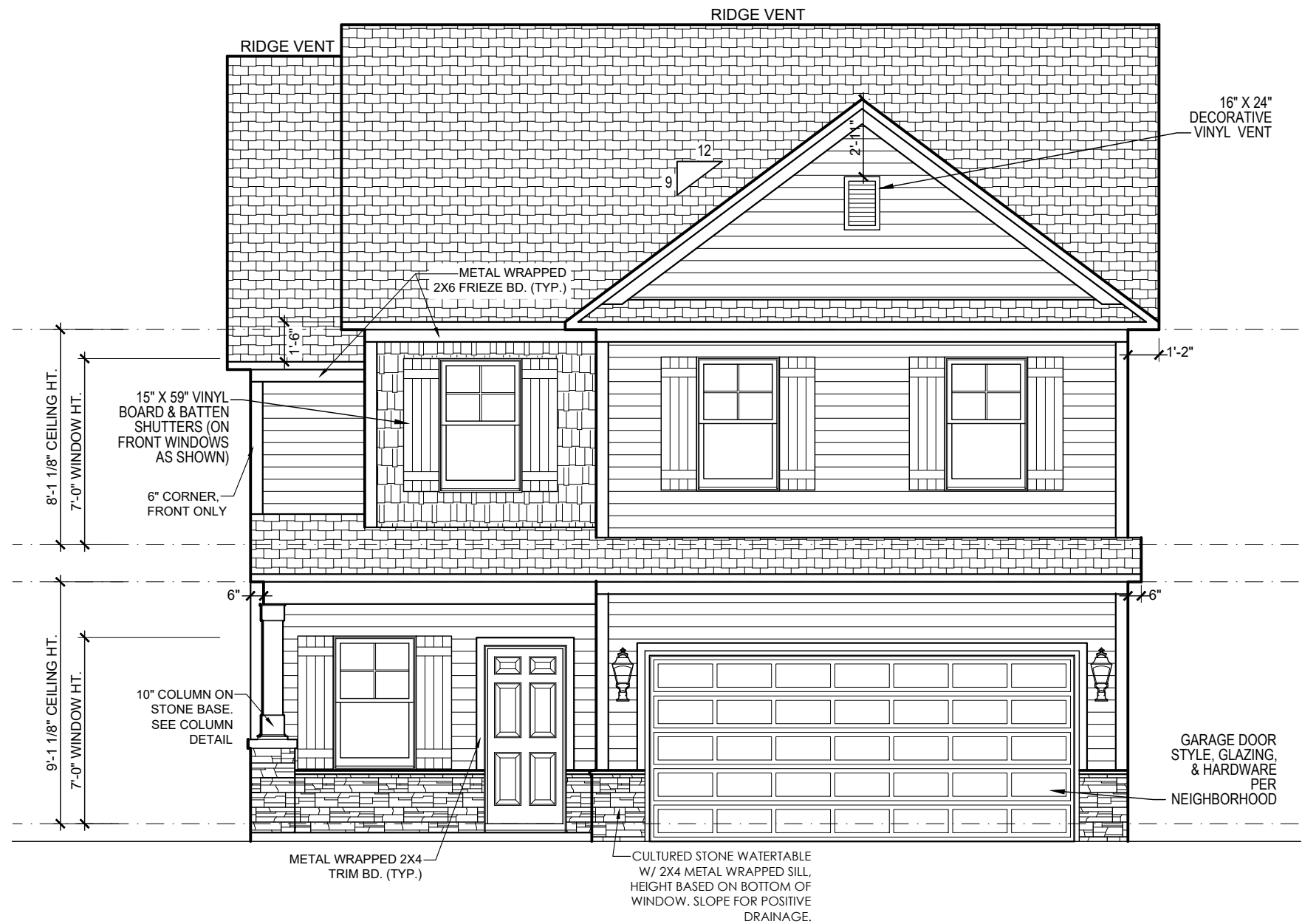

ELEVATION- B - FRONT



**McCLEAN II B**

DRAWN JES/TW  
 CHECKED \_\_\_\_\_  
 DATE 08/10/22  
 PROJ. NO. \_\_\_\_\_  
 PRINTED \_\_\_\_\_

REVISION NO.	REVISION DATE	DESCRIPTION
4	05/24/23	TUBS/SHOWERS
5 JSC	01/31/24	FIREPLACE
6 (jes)	03/4/24	Lighting / Vanity update
7 JSC	05/09/24	FOOTINGS @ PWDR. ROOM

"THESE PLANS, DRAWINGS AND/OR DOCUMENTS AND THE INFORMATION CONTAINED THEREIN ARE CONFIDENTIAL AND PROPRIETARY TO GREAT SOUTHERN HOMES AND ARE "TRADE SECRETS" AS DEFINED BY S.C. CODE ANN. §39-8-20 (5)(a)(b)." COPYRIGHT © 2024

GREATSOUTHERN HOMES CAN NOT GUARANTEE AGAINST ERRORS AND OMISSIONS WITHIN THESE PLANS. THE CONTRACTOR MUST VERIFY ALL DIMENSIONS AND MAY ADJUST THE CONSTRUCTION ACCORDINGLY TO STANDARDS

SQUARE FOOTAGE INFORMATION	
FIRST FLOOR.....	847
SECOND FLOOR.....	1161
GARAGE.....	402
FRONT PORCH.....	72
PATIO.....	138
TOTAL HEATED.....	2008
OPT SUNROOM.....	+138
OPT SUNROOM PATIO.....	115

**GARAGE RIGHT**

DRAWING TITLE  
ELEVATION B  
 DRAWING NO.  
A-5

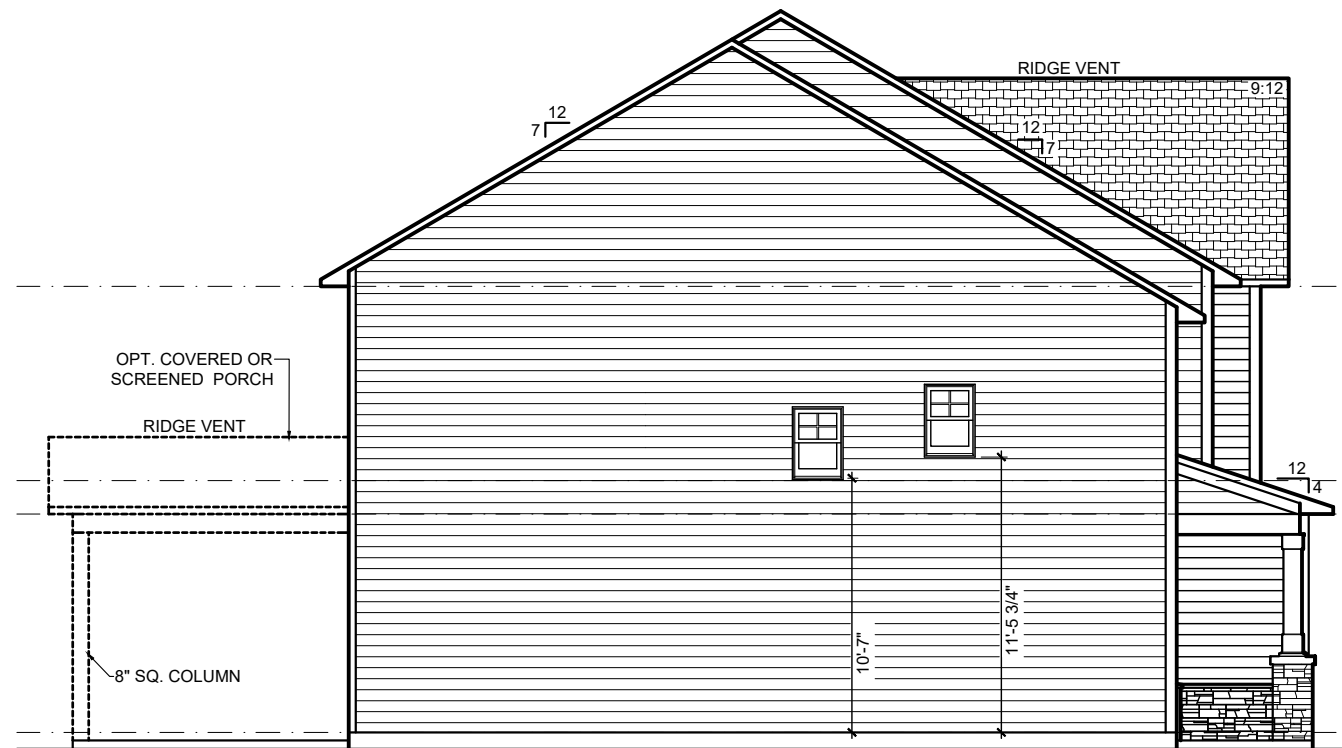

ELEVATION- B & B2 - LEFT

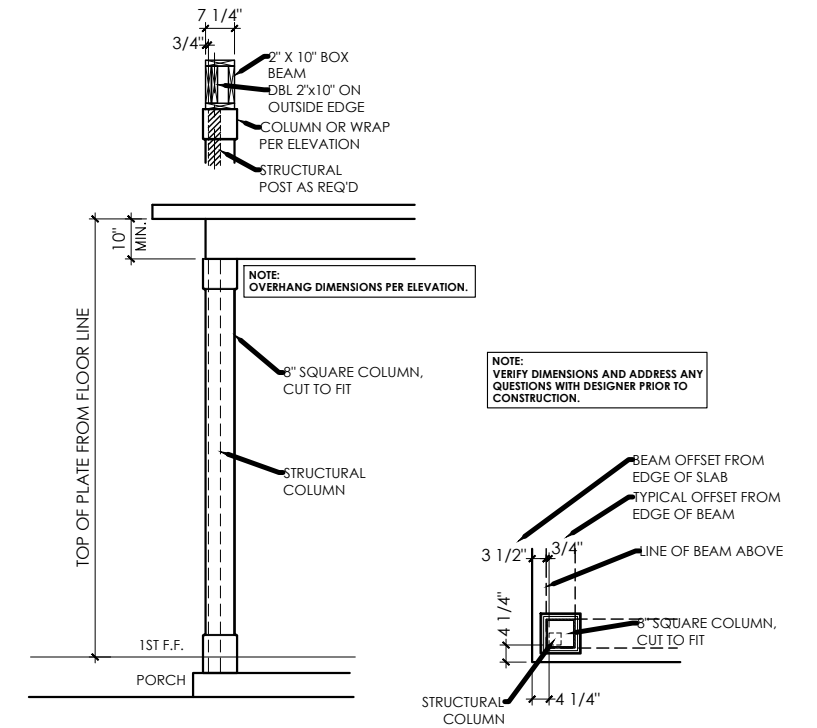

OPT COVERED PATIO COLUMN DETAIL

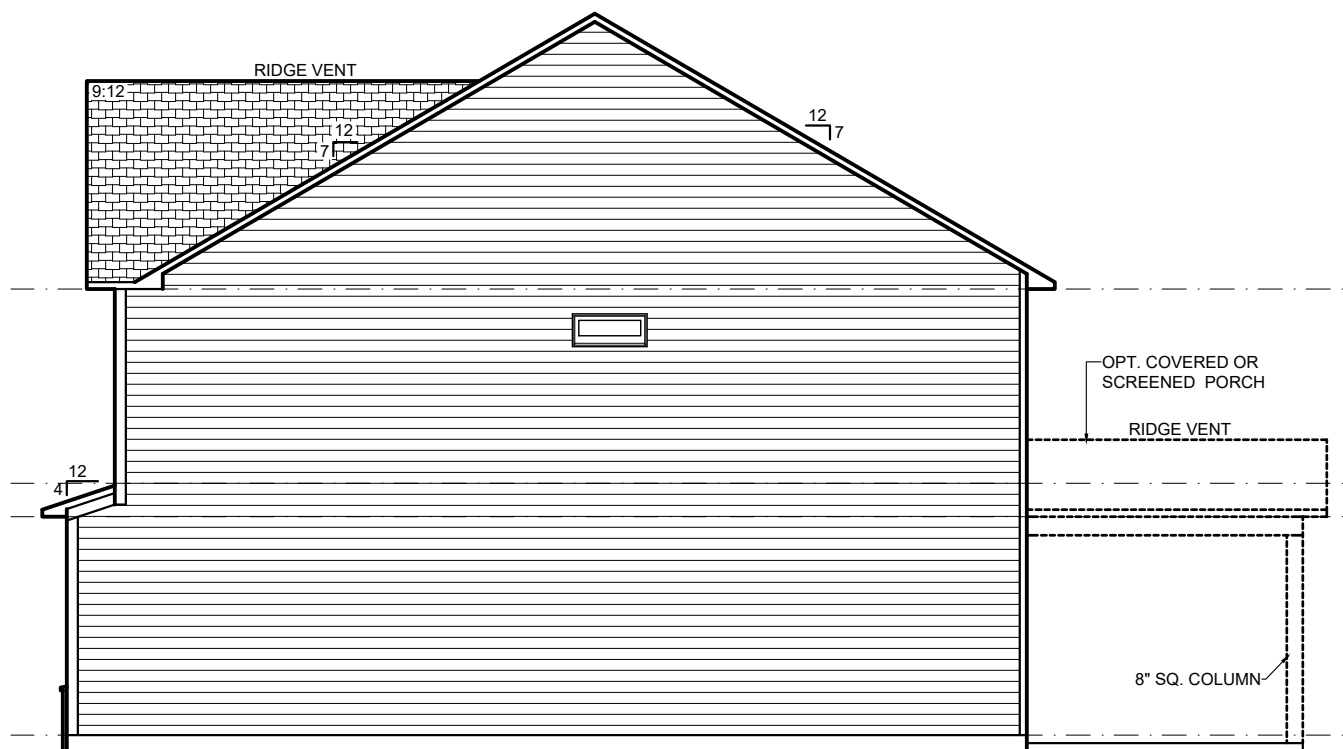

ELEVATION- B & B2- RIGHT

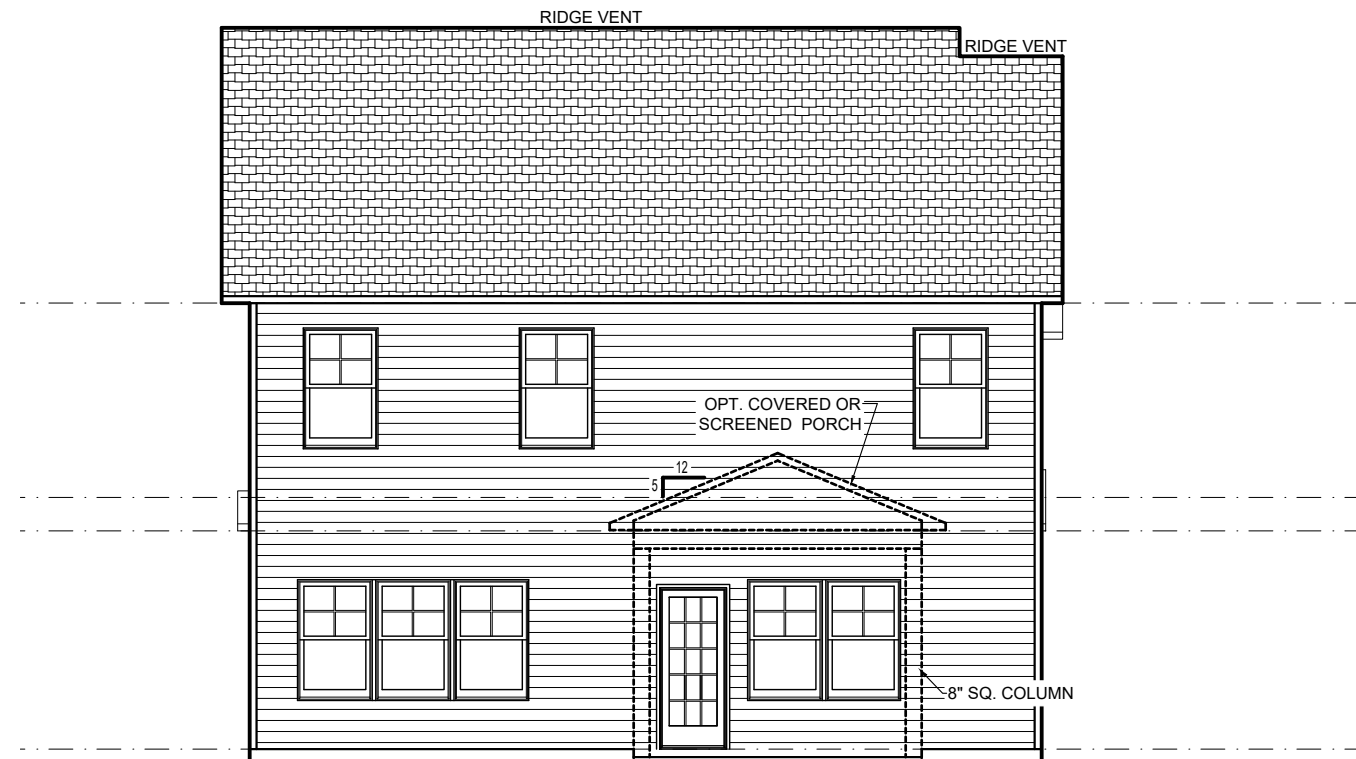

ELEVATION- B & B2- REAR



# McCLEAN II B

DRAWN JES/TW  
 CHECKED \_\_\_\_\_  
 DATE 08/10/22  
 PROJ. NO. \_\_\_\_\_  
 PRINTED \_\_\_\_\_

REVISION NO.	REVISION DATE	DESCRIPTION
4	05/24/23	TUBS/SHOWERS
5 JSC	01/31/24	FIREPLACE
6 (ies)	03/4/24	Lighting / Vanity update
7 JSC	05/09/24	FOOTINGS @ PWDR. ROOM

"THESE PLANS, DRAWINGS AND/OR DOCUMENTS AND THE INFORMATION CONTAINED THEREIN ARE CONFIDENTIAL AND PROPRIETARY TO GREAT SOUTHERN HOMES AND ARE "TRADE SECRETS" AS DEFINED BY S.C. CODE ANN. §39-8-20 (5)(a)(b)." COPYRIGHT © 2024

GREATSOUTHERN HOMES CAN NOT GUARANTEE AGAINST ERRORS AND OMISSIONS WITHIN THESE PLANS. THE CONTRACTOR MUST VERIFY ALL DIMENSIONS AND MAY ADJUST THE CONSTRUCTION ACCORDINGLY TO STANDARDS

SQUARE FOOTAGE INFORMATION	
FIRST FLOOR.....	847
SECOND FLOOR.....	1161
GARAGE.....	402
FRONT PORCH.....	72
PATIO.....	138
TOTAL HEATED.....	2008
OPT SUNROOM.....	+138
OPT SUNROOM PATIO.....	115

**GARAGE RIGHT**

DRAWING TITLE  
ELEVATION B & B2

DRAWING NO.  
A-6

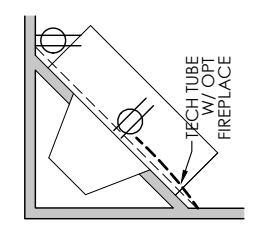
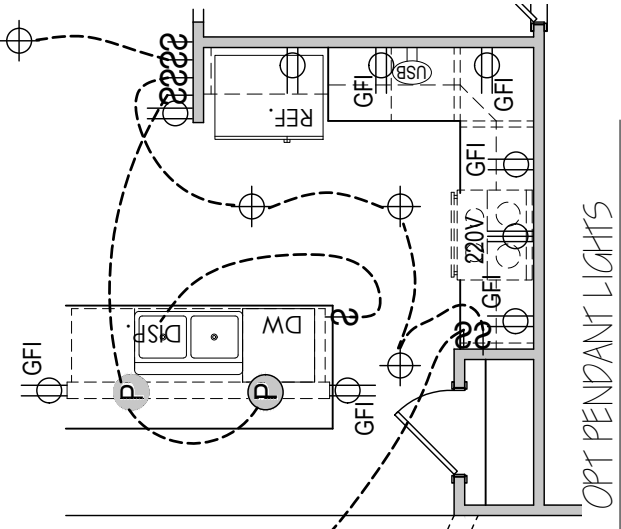
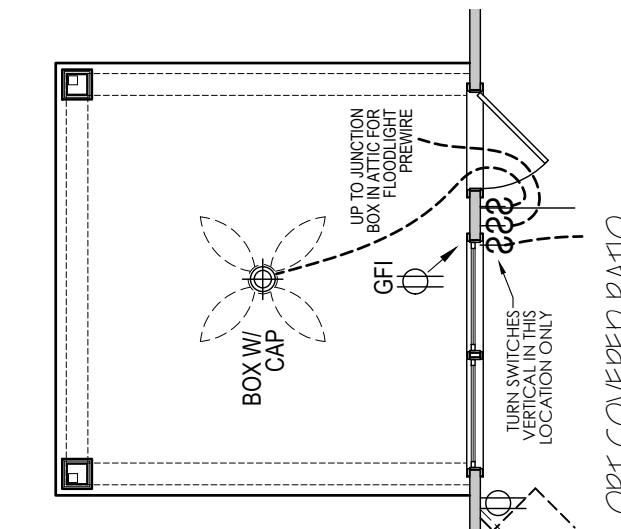
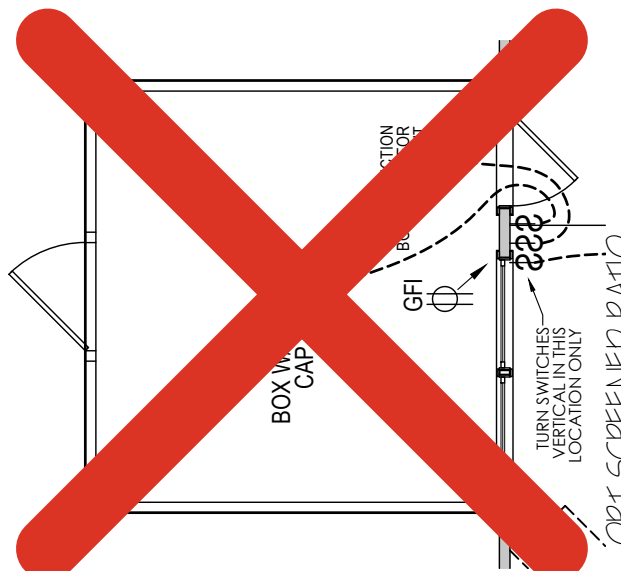

OPT FIREPLACE

ELECTRICAL NOTES

- \* ALLOW FOR SMOKE DETECTORS PER LOCAL CODE REQUIREMENTS (TYPICALLY 1 DOWNSTAIRS, 1 UPSTAIRS IN HALLWAY, & 1 PER BEDROOM)
- \* ALLOW FOR ONE DOORBELL FOR PRIMARY ENTRY DOOR
- \* GAS HEAT - OPTION
- \* GAS H2O - OPTION
- \* PROVIDE CARBON MONOXIDE DETECTORS PER CODE REQUIREMENTS (TYPICALLY W/ GARAGES AND FURNACE AREAS)
- \* ALLOW FOR GARBAGE DISPOSAL AT KITCHEN SINK.
- \* ALLOW FOR FIREPLACE IGNITER IF APPLICABLE.

ELECTRICAL LEGEND

SYMBOL	DESCRIPTION
△	PHONE JACK LOCATION
□	CABLE LOCATION
○	DATA LOCATION
⌘	SWITCHBOX
⌘	110V DUAL RECEPTACLE OUTLET
⌘	220V SINGLE RECEPTACLE OUTLET
⌘	BATH EXHAUST FAN
⌘	SMOKE DETECTOR
⌘	CARBON MONOXIDE DETECTOR
⌘	110V TECHNOLOGY OUTLET
⌘	EXTERIOR DOORBELL BUTTON
⌘	DOORBELL CHIME BOX
⌘	INTERIOR INCANDESCENT KEYLESS
⌘	EXTERIOR ENTRANCE
⌘	DOUBLE SWITCH CEILING FAN PREWIRE - NO LIGHT INSTALLATION - CAP ONLY
⌘	INTERIOR LIGHT LOCATION
⌘	EXTERIOR GOOSENECK
⌘	PENDANT LIGHT

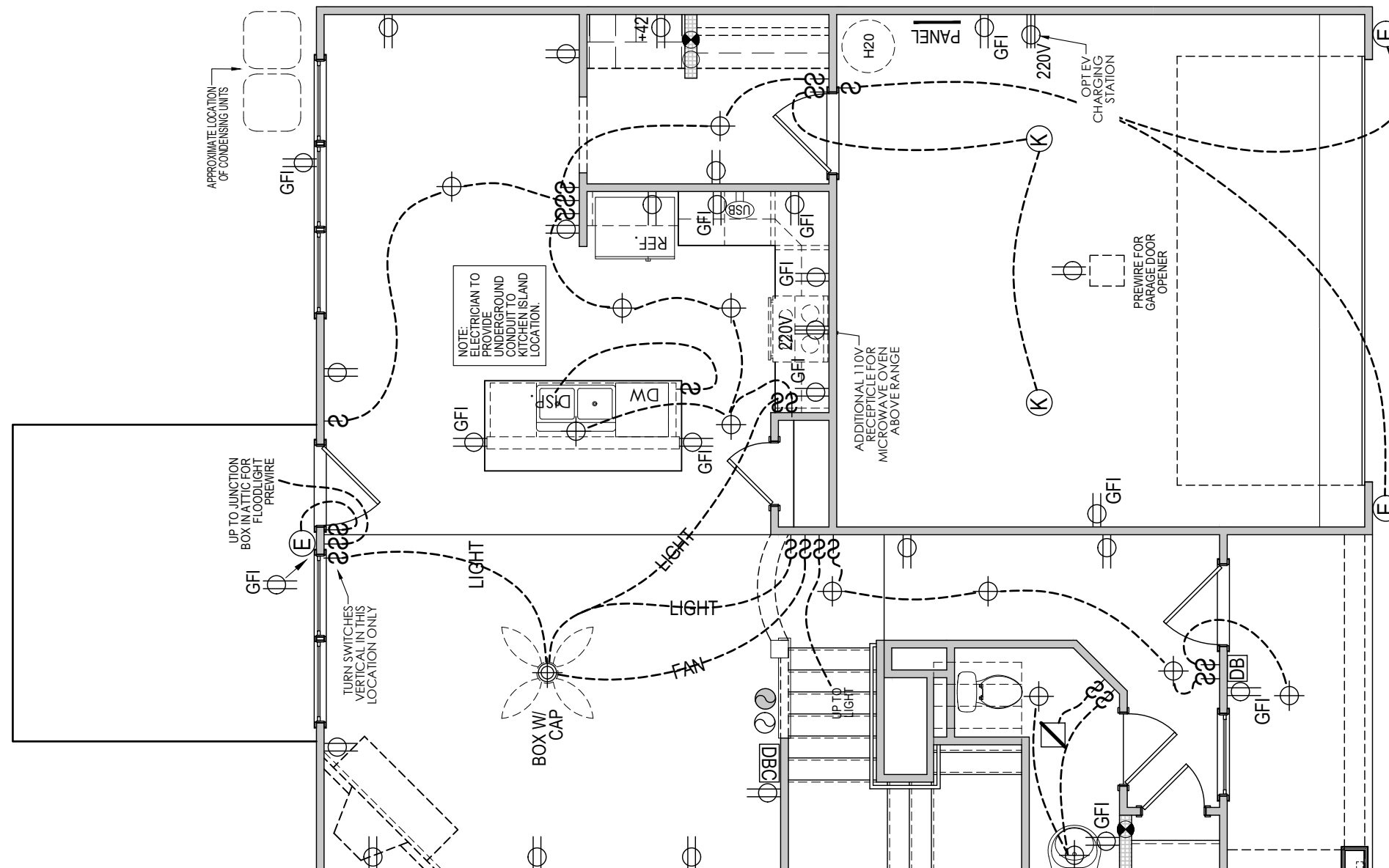

FIRST FLOOR ELECTRICAL PLAN



DRAWN	JES/TW
CHECKED	
DATE	08/10/22
PROJ. NO.	
PRINTED	

REVISION NO.	REVISION DATE	DESCRIPTION
4	05/24/23	TUBS/SHOWERS
5 JSC	01/31/24	FIREPLACE
6 (ies)	03/4/24	Lighting / Vanity update
7 JSC	05/09/24	FOOTINGS @ PWDR. ROOM

"THESE PLANS, DRAWINGS AND/OR DOCUMENTS AND THE INFORMATION CONTAINED THEREIN ARE CONFIDENTIAL AND PROPRIETARY TO GREAT SOUTHERN HOMES AND ARE "TRADE SECRETS" AS DEFINED BY S.C. CODE ANN. §39-8-20 (5)(a)(b)." COPYRIGHT © 2024

GREATSOUTHERN HOMES CAN NOT GUARANTEE AGAINST ERRORS AND OMISSIONS WITHIN THESE PLANS. THE CONTRACTOR MUST VERIFY ALL DIMENSIONS AND MAY ADJUST THE CONSTRUCTION ACCORDINGLY TO STANDARDS

SQUARE FOOTAGE INFORMATION

FIRST FLOOR	847
SECOND FLOOR	1161
GARAGE	402
FRONT PORCH	72
PATIO	138
TOTAL HEATED	2008
OPT SUNROOM	+138
OPT SUNROOM PATIO	115

**GARAGE RIGHT**

DRAWING TITLE	ELEC. PLANS
DRAWING NO.	E-2

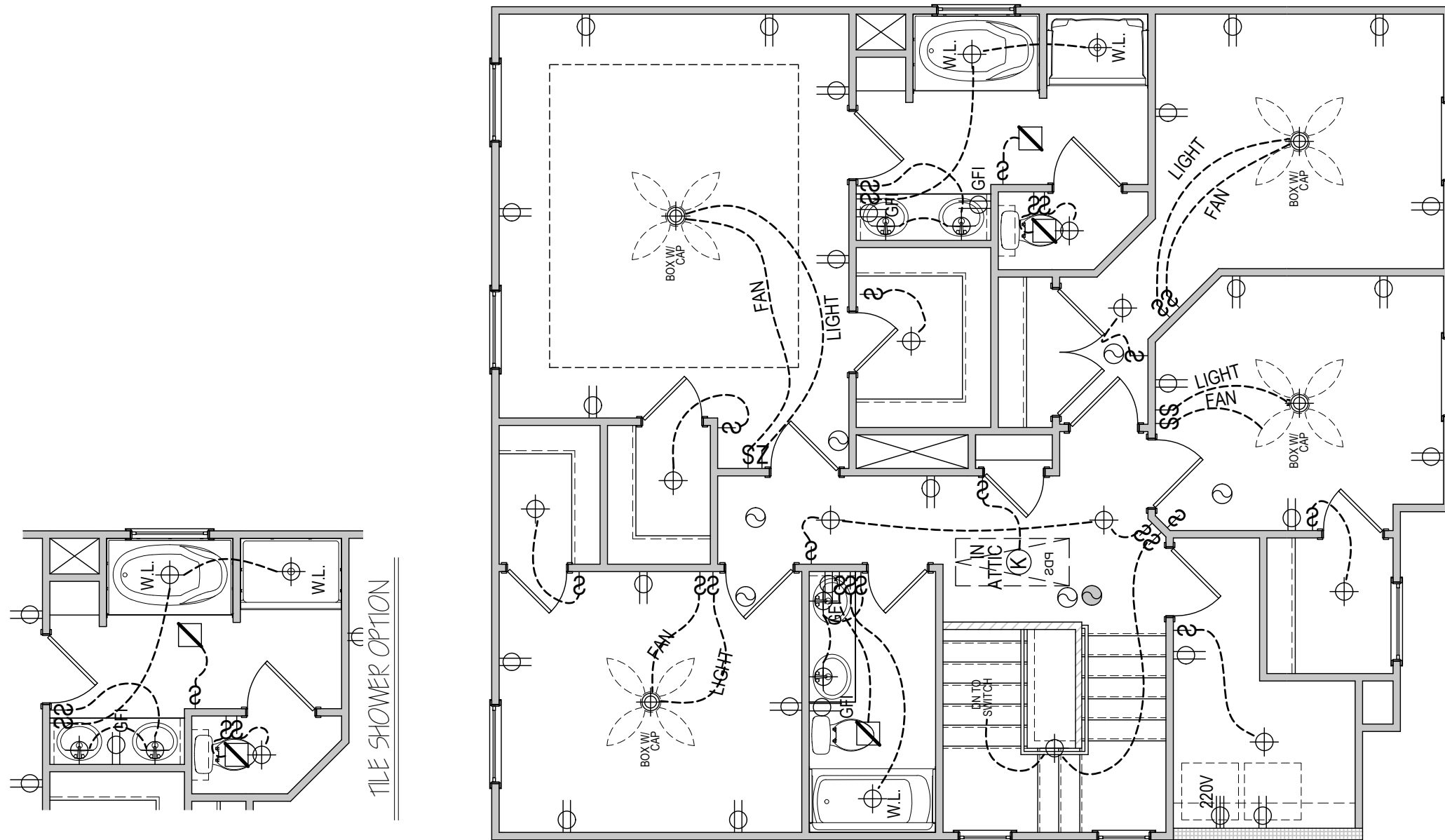

SECOND FLOOR ELECTRICAL PLAN

ELECTRICAL NOTES

* ALLOW FOR SMOKE DETECTORS PER LOCAL CODE REQUIREMENTS (TYPICALLY 1 DOWNSTAIRS, 1 UPSTAIRS IN HALLWAY, & 1 PER BEDROOM)
* ALLOW FOR ONE DOORBELL FOR PRIMARY ENTRY DOOR
* GAS HEAT - OPTION
* GAS H2O - OPTION
* PROVIDE CARBON MONOXIDE DETECTORS PER CODE REQUIREMENTS (TYPICALLY W/ GARAGES AND FURNACE AREAS)
* ALLOW FOR GARBAGE DISPOSAL AT KITCHEN SINK.
* ALLOW FOR FIREPLACE IGNITER IF APPLICABLE.

ELECTRICAL LEGEND

SYMBOL	DESCRIPTION
△	PHONE JACK LOCATION
□	CABLE LOCATION
○	DATA LOCATION
\$	SWITCHBOX
⊕	110V DUAL RECEPTACLE OUTLET
⊕	220V SINGLE RECEPTACLE OUTLET
⊕	BATH EXHAUST FAN
⊕	SMOKE DETECTOR
⊕	CARBON MONOXIDE DETECTOR
⊕	110V TECHNOLOGY OUTLET
⊕	EXTERIOR DOORBELL BUTTON
⊕	DOORBELL CHIME BOX
⊕	INTERIOR INCANDESCENT KEYSLESS
⊕	EXTERIOR ENTRANCE
⊕	DOUBLE SWITCH CEILING FAN PREMISE- NO LIGHT INSTALLATION- CAP ONLY
⊕	INTERIOR LIGHT LOCATION
⊕	EXTERIOR GOOSENECK
⊕	PENDANT LIGHT

DROP BULKHEAD MIN. 5"  
BELOW CEILING TO ALLOW  
CROWN TO CARRY THROUGH

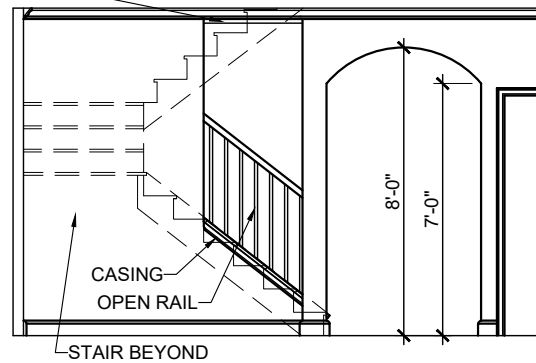

OPT OPEN RAILING

DROP BULKHEAD MIN. 5"  
BELOW CEILING TO ALLOW  
CROWN TO CARRY THROUGH

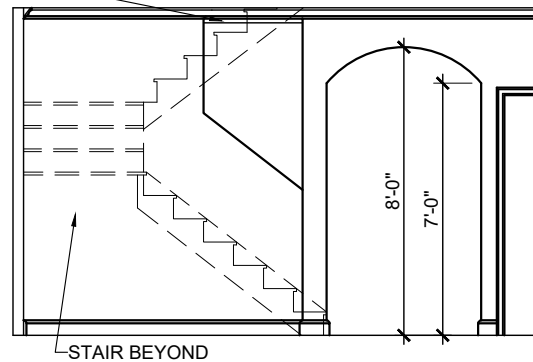

STAIRWAY ARCH

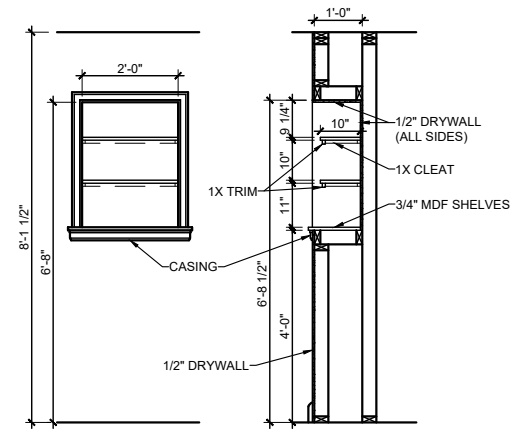

OPT FOYER NICHE

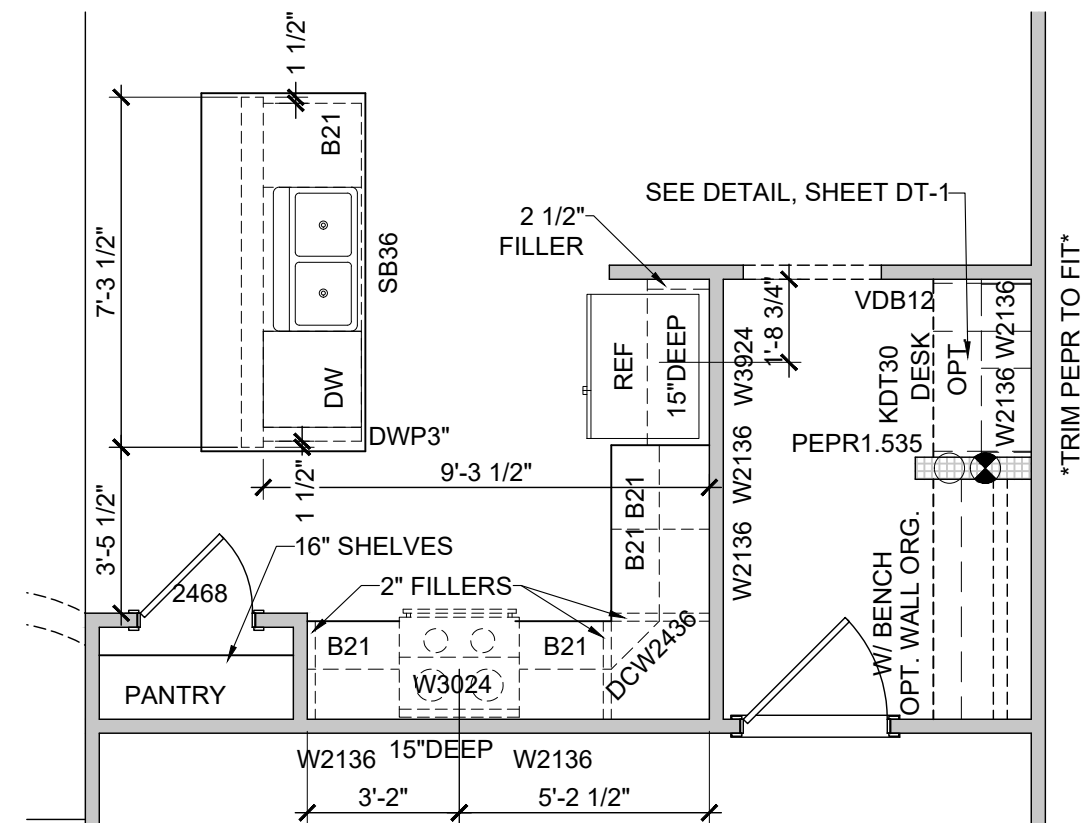

KITCHEN CABINET LAYOUT



# McCLEAN II B

DRAWN JES/TW  
CHECKED \_\_\_\_\_  
DATE 08/10/22  
PROJ. NO. \_\_\_\_\_  
PRINTED \_\_\_\_\_

REVISION NO.	REVISION DATE	DESCRIPTION
4	05/24/23	TUBS/SHOWERS
5 JSC	01/31/24	FIREPLACE
6 (jes)	03/4/24	Lighting / Vanity update
7 JSC	05/09/24	FOOTINGS @ PWDR. ROOM

THESE PLANS, DRAWINGS AND/OR DOCUMENTS AND THE INFORMATION CONTAINED THEREIN ARE CONFIDENTIAL AND PROPRIETARY TO GREAT SOUTHERN HOMES AND ARE "TRADE SECRETS" AS DEFINED BY S.C. CODE ANN. §39-8-20 (5)(a)(b).\*

GREATSOUTHERN HOMES CAN NOT GUARANTEE AGAINST ERRORS AND OMISSIONS WITHIN THESE PLANS. THE CONTRACTOR MUST VERIFY ALL DIMENSIONS AND MAY ADJUST THE CONSTRUCTION ACCORDINGLY TO STANDARDS

SQUARE FOOTAGE INFORMATION

FIRST FLOOR.....	847
SECOND FLOOR.....	1161
GARAGE.....	402
FRONT PORCH.....	72
PATIO.....	138
TOTAL HEATED.....	2008
OPT SUNROOM.....	+138
OPT SUNROOM PATIO.....	115

## GARAGE RIGHT

DRAWING TITLE  
DETAILS  
DRAWING NO.  
DT-1