



Bateman Civil Survey Company, PC

2524 Reliance Avenue
Apex, NC 27539
(919) 577-1080/fax (919) 577-1080

September 18, 2024

Harnett County Environmental Health Department
Harnett County Environmental Health,
900 S 9th St.
Lillington NC 27546

RE: Wastewater Daily Flow Calculations

Birchwood Grove Lot 143
589 Thomas Gage Drive, Fuquay Varina, Harnett County, North Carolina
Project #3753

Dear Harnett County Staff:

Bateman Civil Survey Company in conjunction with Central Carolina Soil Consulting (CCSC) are proposing wastewater daily flow calculations for a single-family home located at Birchwood Grove Lot 143 pursuant to session law 2014-120 and 2013-413. The proposed home will have **5** bedrooms and under the current flow calculations provided in the state rules would have a daily flow of **600** gallons per day. That would be based on 120 gallons per bedroom.

Household flow rates from the 15 NCAC 18A section of the state rules relied on fixture flow rates from 1982 and calculated the flows for common fixtures to established average flows for the purpose of calculating household daily flows and septic system based on those flows. The data for the historic fixture flows was taken from the EPA 2002 Onsite Wastewater Treatment Systems Manual.

The attached spreadsheet contains the flow reducing fixtures that are proposed for Birchwood Grove Lot 143. The table includes flow rates for the flow reducing fixtures as well as flow rates from the state rules and the percentage of water savings. On average the proposed fixtures provide a 40% savings.

We are requesting a reduction of 20% for the use of low flow fixtures. This will provide an adjusted daily flow of 96 gallons per bedroom per day and a total flow of **480** gallons per day for the proposed 5-bedroom house.

Calculations for effluent strength are shown below based on a 20% reduction in flow with a base flow concentration of 220 mg/l for both BODs and TSS. High strength effluent levels are considered to be higher than 350 mg/l for both BODs and TSS. Based on a reduction in flow of 20% we anticipate the concentration levels of both BODs and TSS to be around 275 mg/l well below the 350 mg/l threshold.

If you need further information or have any questions, please contact Matt Burdette at (919) 422-2827 or Tom Speight at 919-577-1080 2524 Reliance Ave, Apex NC 27539.

Sincerely,

BATEMAN CIVIL SURVEY COMPANY
NCBELS# C-2378.

DocuSigned by:
Thomas Speight, Jr, P.E, PLS
09838E23DC404AD...



Thomas Speight, P.E
(seal)

Birchwood Grove Lot 143						
	Item		Gal/min. or flush	Number of Fixures	Base Flow From 1982	Percent Water Savings
Master	Shower Head	Moen T5152EP	1.8 gal/minute	1	5.5 gal/minute	67%
	Lavatory Faucet	Moen 5010	1.2 gal/minute	2	3.0 gal/minute	60%
Kitchen	Kitchen Sink Faucet	Moen 5925	1.5 gal/minute	1	3.0 gal/minute	50%
Powder	Laundry Faucet	Moen 5010	1.2 gal/minute	1	3.0 gal/minute	60%
Laundry	Kitchen Sink Faucet	Moen 5925	1.5 gal/minute	1	3.0 gal/minute	50%
Bath 2	Lavatory Faucet	Moen 5010	1.2 gal/minute	1	3.0 gal/minute	60%
	Shower Head	Moen T5153EP	1.8 gal/minute	1	5.5 gal/minute	67%
Bath 3	Lavatory Faucet	Moen 5010	1.2 gal/minute	1	3.0 gal/minute	60%
	Shower Head	Moen T5152EP	1.8 gal/minute	1	5.5 gal/minute	67%
Bath 4	Lavatory Faucet	Moen 5010	1.2 gal/minute	1	3.0 gal/minute	60%
	Shower	Moen T5153EP	1.8 gal/minute	1	5.5 gal/minute	67%
Toilets	Master, Powder, 2, 3, 4	Gerber 28-990	1.3 gal /flush	5	3.5 gal/minute	63%

FIXTURES	TOILET	FAUCET	SHOWER	LEAK	BATH	OTHER	DISHWASHER	CLOTHES WASHER	TOTALS
PERCENT OF HOUSE HOLD WATER USE	24%	20%	20%	12%	3%	3%	2%	16%	100%
GALLONS PER DAY (600 BASE)	144	120	120	72	18	18	12	96	600
PERCENT OF SAVINGS FROM WATER SAVING FIXURES	63%	58% avg	67%	0%	0%	0%	0%	0%	40%
ADJUSTED FLOW (GALLONS)	53	50	40	72	18	18	12	96	359

MOEN®

Specifications

DESCRIPTION

- Metal construction with various finishes identified by suffix
- Pressure balancing cycle valve design with an adjustable temperature limit stop
- 1/2" IPS connections
- Includes valve, tub spout, showerhead, arm and flange

OPERATION

- Lever style handle
- Handle operates counterclockwise through a 270° arc with off at 6 o'clock and maximum hot at the 9 o'clock position. Shut off in clockwise direction
- Adjustable temperature limit stop to control maximum hot water temperature
- Pressure balancing mechanism maintains selected discharge temperature to ± 2°

FLOW

- EP suffix models are designed to deliver 1.75 gpm (6.6 L/min) at 45 psi

STANDARDS

- Third party certified to: WaterSense®, ASME A112.18.1/CSA B-125.1 and all applicable requirements referenced therein
- Products marked with 1.75 gpm are compliant with California water efficiency regulations
- ADA  for lever handle

WARRANTY

- Lifetime limited warranty against leaks, drips and finish defects to the original homeowner
 - 10 year limited warranty when used in a multifamily installation
 - 5 year limited warranty when used in a commercial installation
- Visit www.moen.com/support for complete details and limitations



Seena™ Posi-Temp® Single-Handle Tub/Shower

Models: T5152EP series - shower trim only
T5153EP series - tub/shower trim



EP Suffix Models Only

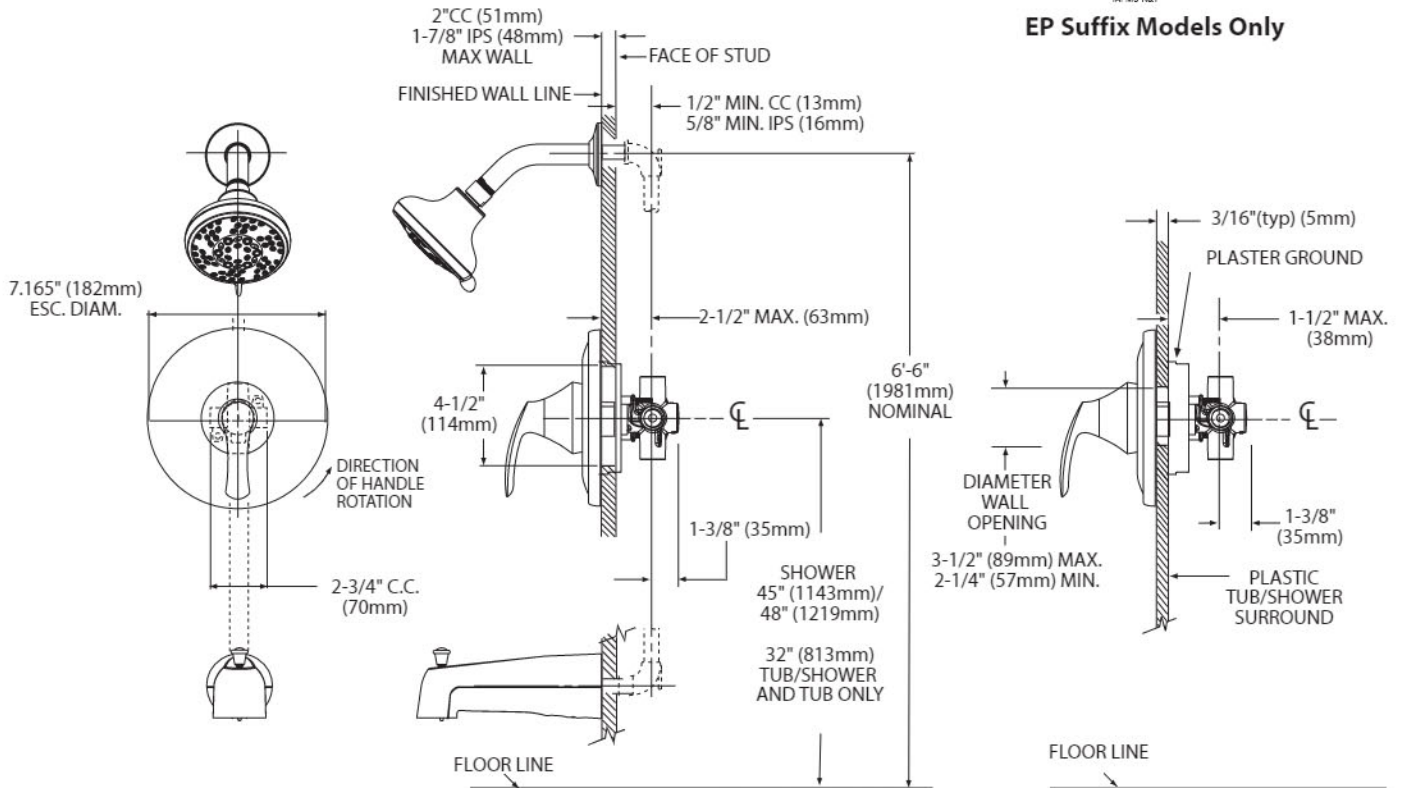

MOEN®

Specifications

DESCRIPTION

- Metal construction with finish identified by suffix
- 1/2" IPS connections for flexible hoses only; not for use with rigid or semi-rigid supply risers (3/8" Copper or Pex) with coupling nuts
- Installation through 3 holes, 1" min. diameter, and 4" on center
- Includes pop-up waste assembly

OPERATION

- Lever handles
- Maximum handle rotation angle is 90° to full on
- Hot side counterclockwise to open (clockwise to close)
- Cold side clockwise to open (counterclockwise to close)

FLOW

- Water usage is limited to the maximum flow rates as indicated by the corresponding product markings
 - 1.2 gpm max (4.5 L/min) at 60 psi

CARTRIDGE

- 1234 cartridge
- Nonmetallic and stainless steel material

STANDARDS

- Third party certified at WaterSense®, ASME A112.18.1/CSA B125.1, and all applicable requirements referenced therein including NSF 61/9 & 372
- Products marked with 1.2 gpm are compliant with California water efficiency regulations
- Complies with California Proposition 65 and with the Federal Safe Drinking Water Act
- ADA ♿ for lever handles

WARRANTY

- Limited lifetime warranty against leaks, drips and finish defects to the original consumer purchaser
- 10 year warranty when used in a multifamily installation
- 5 year warranty when used in a commercial installation

Visit www.moen.com/support for complete details and limitations

OPTIONS (See Illustrated Parts page)

- Thin and thick deck mounting hardware kits available

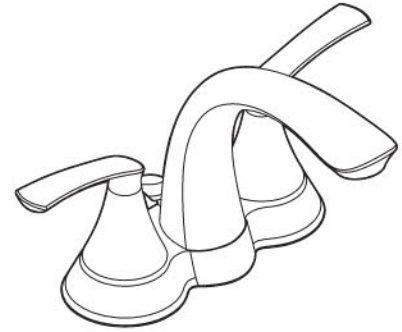

SEENA™

Two-Handle 4" Centerset Lavatory Faucet

Models:

5010 series includes pop-up waste

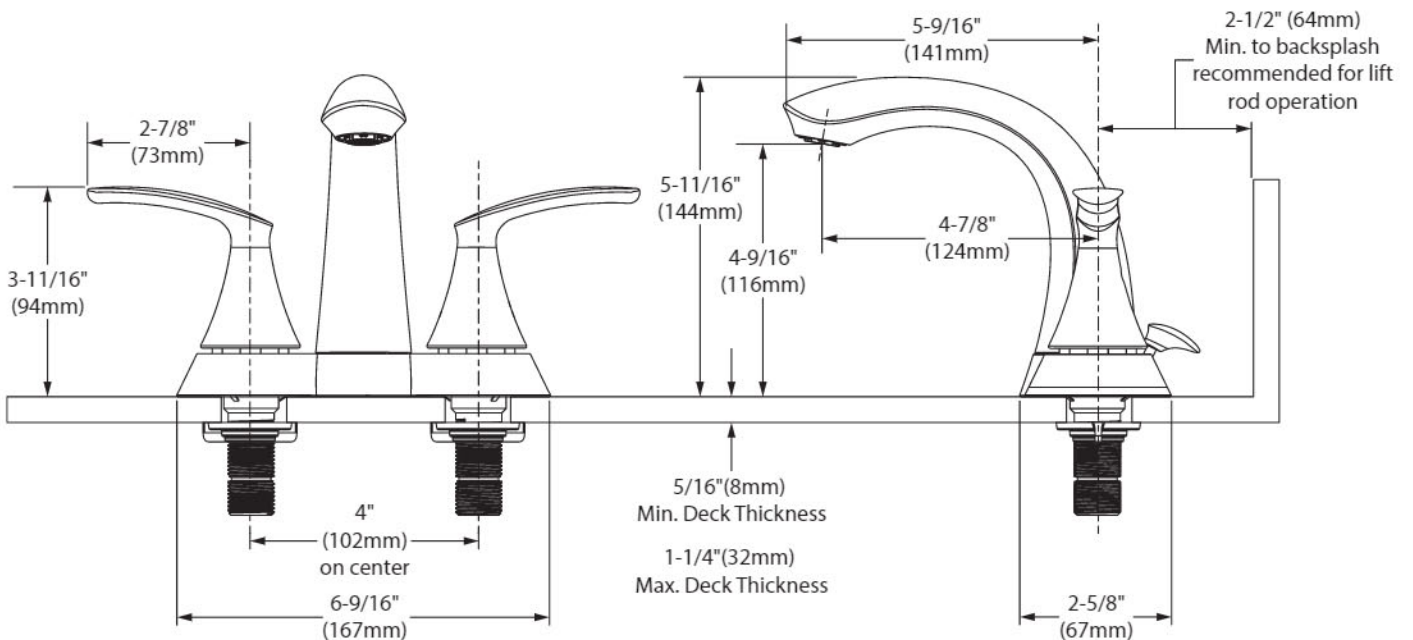

CRITICAL DIMENSIONS

(DO NOT SCALE)



Specifications

FAUCET DESCRIPTION

- Pulldown system offers smooth operation, easy movement and secure docking
- Metal construction with various finishes identified by suffix
- Quick connect installation - Duralock™
- PowerBoost™ spray technology
- Pulldown spray with 68" braided hose
- Flexible supply lines with 3/8" compression fittings
- High arc spout provides height and reach to fill or clean large pots while pulldown wand provides the maneuverability for cleaning or rinsing
- Faucet designed for handle to be mounted on right side

OPERATION

- Lever style handle
- Temperature controlled by 100° arc of handle travel
- Operates with less than 5 lbs. of force
- Operates in stream or spray mode in the pullout or retracted position

FLOW

- Flow is limited to 1.5 gpm (5.7 L/min) max at 60 psi

CARTRIDGE

- 1255™ Duralast™ cartridge for single handle faucets

STANDARDS

- Third party certified to IAPMO Green, ASME A112.18.1/CSA B125.1 and all applicable requirements therein including NSF 61/9 & 372
- Meets CalGreen and Georgia SB370 requirements
- Complies with California Proposition 65 and with the Federal Safe Drinking Water Act
- The backflow protection system in the device consists of two independently operating check valves, a primary and a secondary which prevent backflow
- ADA ♿ for lever handle

WARRANTY

- Lifetime limited warranty against leaks, drips and finish defects to the original homeowner
- 10 year limited warranty when used in a multifamily installation
- 5 year limited warranty when used in a commercial installation

Visit www.moen.com/support for complete details and limitations

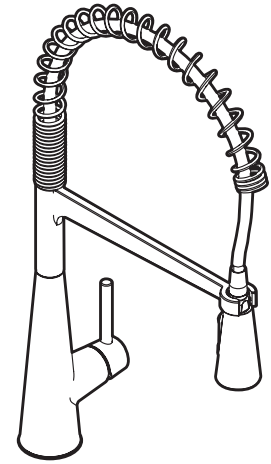

Sleek™
Single Handle Pre-Rinse Spring
Pulldown Kitchen Faucet

Model: 5925 series

NOTE: this faucet is designed to be installed through 1 or 3 holes, 1-1/2" (38mm) min. dia.

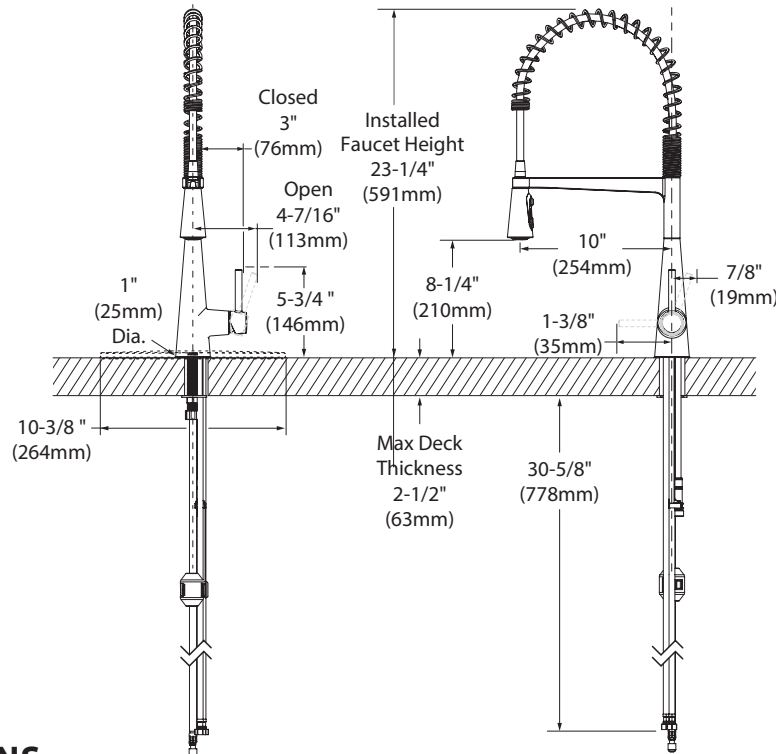

CRITICAL DIMENSIONS

(DO NOT SCALE)



VITREOUS CHINA

TOILET
21-918

LAVATORIES

TOILETS

BIDETS / URINALS

CAST IRON



MAXWELL® 1.28
ErgoHeight™
17" High Elongated Toilet

12" Rough-in

Features:

- 1.28 gpf/4.8 Lpf high efficiency two-piece toilet
- Elongated ErgoHeight™ bowl
- Dual-fed siphon jet
- Pilot fill valve
- 3" flush valve
- 2" glazed trapway
- Color matched front tank lever (white only)
- Optional insulated non-sweating tank
- Optional right-handed trip lever
- Available in White, Bone and Biscuit
- 2 bolt caps
- ADA Compliant



Specifications: Bowl—#21-928 Front Bowl
Seat not included

Tank—#28-990

Dimensions:

- Height 30 1/8"
- Width 17 1/2"
- Depth 28 1/2"
- Rough-in 12"
- Water Surface from Rim 6 1/2"
- Trapway 2"
- Water Surface 8 7/8" x 7 3/8"
- Water Seal 2 1/4"
- Shipping Weight 85.5 lbs

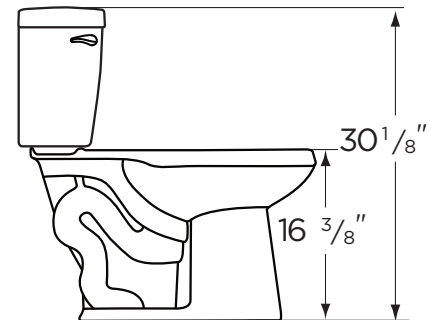
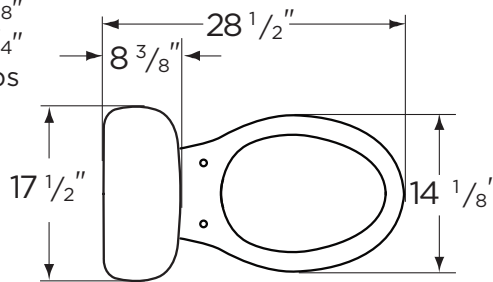

THIS FIXTURE QUALIFIES ACCORDING TO ASME TEST PROCEDURES AS A HIGH EFFICIENCY WATER CLOSET WITH AN AVERAGE CONSUMPTION OF 1.28 gpf (4.8 Lpf) OR LESS.



Job Name	
Date	
Model Specified	
Quantity	
Customer	
Contractor	
Architect/engineer	

www.gerberonline.com