

Trenco
818 Soundside Rd
Edenton, NC 27932

Re: J0424-2222
Wellco/Lot 10 Overhills Creek/Harnett

The truss drawing(s) referenced below have been prepared by Truss Engineering Co. under my direct supervision based on the parameters provided by Comtech, Inc - Fayetteville.

Pages or sheets covered by this seal: I64935114 thru I64935127

My license renewal date for the state of North Carolina is December 31, 2024.

North Carolina COA: C-0844



April 17, 2024

Gilbert, Eric

IMPORTANT NOTE: The seal on these truss component designs is a certification that the engineer named is licensed in the jurisdiction(s) identified and that the designs comply with ANSI/TPI 1. These designs are based upon parameters shown (e.g., loads, supports, dimensions, shapes and design codes), which were given to MiTek or TRENCO. Any project specific information included is for MiTek's or TRENCO's customers file reference purpose only, and was not taken into account in the preparation of these designs. MiTek or TRENCO has not independently verified the applicability of the design parameters or the designs for any particular building. Before use, the building designer should verify applicability of design parameters and properly incorporate these designs into the overall building design per ANSI/TPI 1, Chapter 2.

Job J0424-2222	Truss A1	Truss Type ROOF SPECIAL	Qty 6	Ply 1	Wellco/Lot 10 Overhills Creek/Harnett Job Reference (optional)	I64935114
-------------------	-------------	----------------------------	----------	----------	---	-----------

Comtech, Inc. Fayetteville, NC - 28314,

8.430 s Jan 6 2022 MiTek Industries, Inc. Tue Apr 16 10:01:09 2024 Page 1

ID:Yb7beGiAPPG119hchw?SQjyfOh?Rfc?PsB70Hq3NSgPqnL8w3ulTXbGKWrCDoi7J4zJC?f

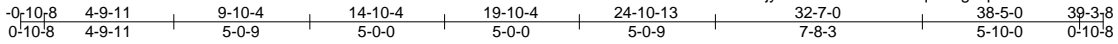

4x8 =

Scale = 1:85.5

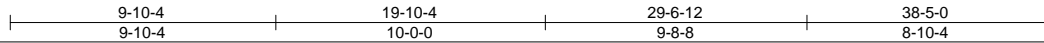
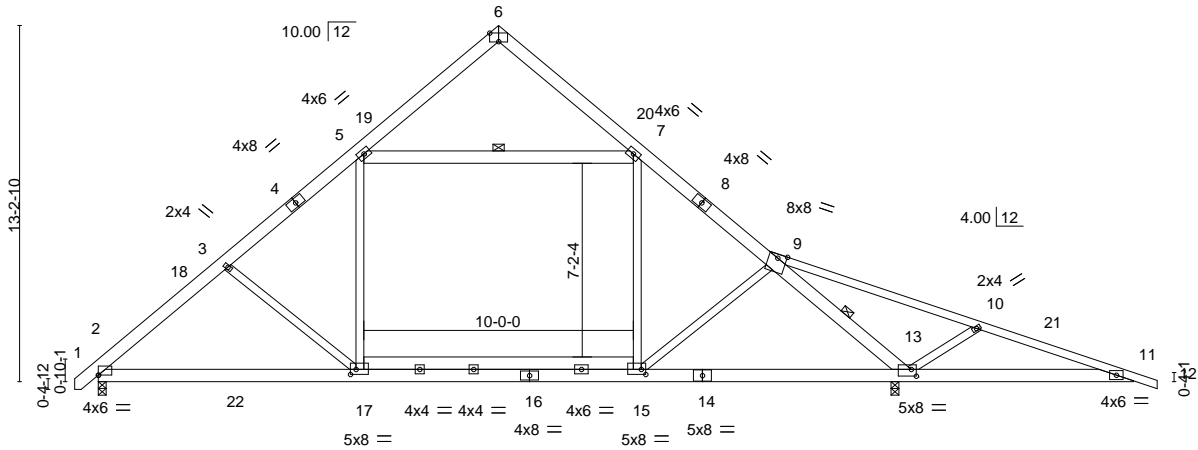

Plate Offsets (X,Y)--	[6:0-4-0,Edge], [13:0-2-4,0-3-0], [15:0-2-0,0-2-4], [17:0-2-8,0-2-4]
-----------------------	--

LOADING (psf)	SPACING-	CSI.	DEFL.	PLATES	GRIP
TCLL 20.0	2-0-0	TC 0.68	in (loc) l/defl L/d	MT20	244/190
TCDL 10.0	Plate Grip DOL 1.15	BC 0.67	Vert(LL) -0.30 2-17 >999 360		
BCLL 0.0 *	Lumber DOL 1.15	WB 0.28	Vert(CT) -0.42 2-17 >863 240		
BCDL 10.0	Rep Stress Incr YES	Matrix-S	Horz(CT) 0.03 13 n/a n/a		
	Code IRC2015/TP12014		Wind(LL) -0.32 13-15 >999 240	Weight: 301 lb	FT = 20%

LUMBER-	BRACING-
TOP CHORD 2x6 SP No.1 *Except* 9-12: 2x4 SP No.1	TOP CHORD Structural wood sheathing directly applied or 5-9-8 oc purlins. Except: 1 Row at midpt 9-13
BOT CHORD 2x6 SP No.1	BOT CHORD Rigid ceiling directly applied or 10-0-0 oc bracing, Except: 6-0-0 oc bracing: 11-13.
WEBS 2x4 SP No.2 *Except* 15-17,5-7: 2x6 SP No.1	WEBS 1 Row at midpt 5-7

REACTIONS. (size) 2=0-3-8, 13=0-3-8
 Max Horz 2=319(LC 10)
 Max Uplift 2=66(LC 12), 13=254(LC 9)
 Max Grav 2=1462(LC 19), 13=2047(LC 2)

FORCES. (lb) - Max. Comp./Max. Ten. - All forces 250 (lb) or less except when shown.
 TOP CHORD 2-3=-1820/228, 3-5=-1669/224, 5-6=-282/114, 6-7=-362/160, 7-9=-1542/163,
 9-13=-2489/938, 9-10=-1002/1311, 10-11=-824/814
 BOT CHORD 2-17=-145/1502, 15-17=0/1243, 13-15=-36/1081, 11-13=-710/840
 WEBS 10-13=-592/323, 5-17=0/756, 7-15=0/471, 5-7=-1016/220, 9-15=-299/366,
 3-17=-337/256

- NOTES-**
- Unbalanced roof live loads have been considered for this design.
 - Wind: ASCE 7-10; Vult=130mph Vasd=103mph; TCDL=6.0psf; BCDL=6.0psf; h=15ft; Cat. II; Exp C; Enclosed; MWFRS (envelope) and C-C Exterior(2) 0-9-1 to 3-7-12, Interior(1) 3-7-12 to 14-10-4, Exterior(2) 14-10-4 to 19-3-1, Interior(1) 19-3-1 to 39-3-8 zone; cantilever right exposed ;C-C for members and forces & MWFRS for reactions shown; Lumber DOL=1.60 plate grip DOL=1.60
 - This truss has been designed for a 10.0 psf bottom chord live load nonconcurrent with any other live loads.
 - * This truss has been designed for a live load of 30.0psf on the bottom chord in all areas where a rectangle 3-6-0 tall by 2-0-0 wide will fit between the bottom chord and any other members, with BCDL = 10.0psf.
 - Provide mechanical connection (by others) of truss to bearing plate capable of withstanding 66 lb uplift at joint 2 and 254 lb uplift at joint 13.
 - Graphical purlin representation does not depict the size or the orientation of the purlin along the top and/or bottom chord.



April 17, 2024

<p>WARNING - Verify design parameters and READ NOTES ON THIS AND INCLUDED MITEK REFERENCE PAGE MII-7473 rev. 1/2/2023 BEFORE USE.</p> <p>Design valid for use only with MiTek® connectors. This design is based only upon parameters shown, and is for an individual building component, not a truss system. Before use, the building designer must verify the applicability of design parameters and properly incorporate this design into the overall building design. Bracing indicated is to prevent buckling of individual truss web and/or chord members only. Additional temporary and permanent bracing is always required for stability and to prevent collapse with possible personal injury and property damage. For general guidance regarding the fabrication, storage, delivery, erection and bracing of trusses and truss systems, see ANSI/TPH Quality Criteria and DSB-22 available from Truss Plate Institute (www.tpinst.org) and BCSI Building Component Safety Information available from the Structural Building Component Association (www.sbcacomponents.com)</p>	<p>ENGINEERING BY</p> <p>TRENCO</p> <p>A MiTek Affiliate</p> <p>818 Soundside Road Edenton, NC 27932</p>
--	---

Job J0424-2222	Truss A2	Truss Type ROOF SPECIAL	Qty 5	Ply 1	Wellco/Lot 10 Overhills Creek/Harnett 164935115
-------------------	-------------	----------------------------	----------	----------	--

Comtech, Inc. Fayetteville, NC - 28314,

8.430 s Jan 6 2022 MiTek Industries, Inc. Tue Apr 16 10:01:09 2024 Page 1

ID:Yb7beGiAPPG119hcv?SQjyfOh?RfC?PsB70Hq3NSgPqnL8w3ulTXbGKWrCDoi7J4zJC?f

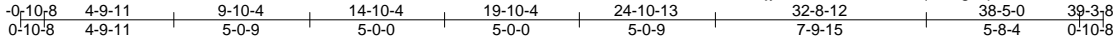

4x8 =

Scale = 1:85.5

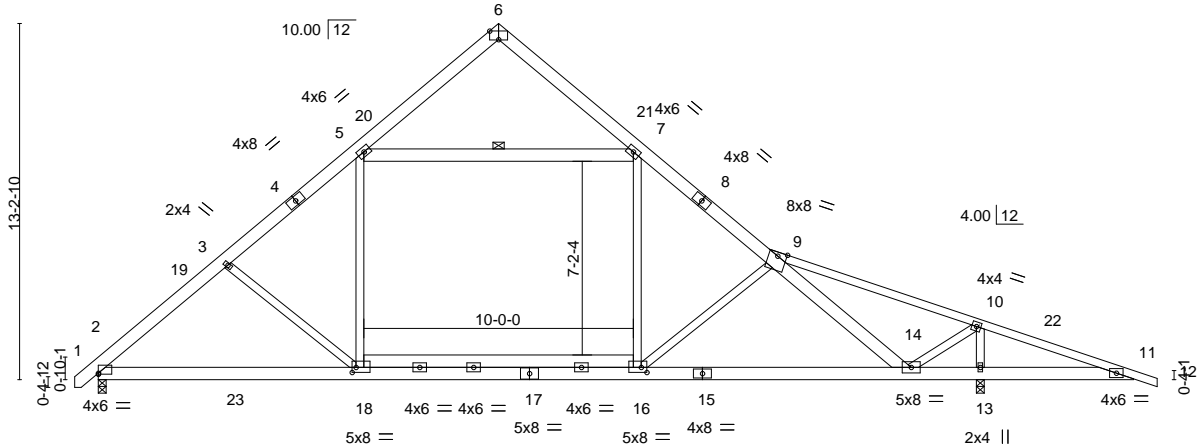

Plate Offsets (X,Y)--	[2:0-0-0,0-0-7], [6:0-4-0,Edge], [16:0-2-8,0-2-4], [18:0-1-12,0-2-4]
-----------------------	--

LOADING (psf)	SPACING-	CSI.	DEFL.	PLATES	GRIP
TCLL 20.0	2-0-0	TC 0.57	in (loc) l/defl L/d	MT20	244/190
TCDL 10.0	Plate Grip DOL 1.15	BC 0.69	Vert(LL) -0.30 14-16 >999 360		
BCLL 0.0 *	Lumber DOL 1.15	WB 0.46	Vert(CT) -0.44 14-16 >889 240		
BCDL 10.0	Rep Stress Incr YES	Matrix-S	Horz(CT) 0.04 13 n/a n/a		
	Code IRC2015/TP12014		Wind(LL) 0.27 14-16 >999 240	Weight: 303 lb	FT = 20%

LUMBER-	BRACING-
TOP CHORD 2x6 SP No.1 *Except* 9-12: 2x4 SP No.1	TOP CHORD Structural wood sheathing directly applied or 5-5-5 oc purlins.
BOT CHORD 2x6 SP No.1	BOT CHORD Rigid ceiling directly applied or 6-0-0 oc bracing.
WEBS 2x4 SP No.2 *Except* 16-18,5-7: 2x6 SP No.1	WEBS 1 Row at midpt 5-7

REACTIONS. (size) 2=0-3-8, 13=0-3-8
 Max Horz 2=319(LC 10)
 Max Uplift 2=66(LC 12), 13=177(LC 9)
 Max Grav 2=1621(LC 19), 13=1881(LC 2)

FORCES. (lb) - Max. Comp./Max. Ten. - All forces 250 (lb) or less except when shown.
 TOP CHORD 2-3=2079/327, 3-5=1916/335, 5-6=348/131, 6-7=316/140, 7-9=1954/292,
 9-14=1382/558, 9-10=1032/32, 10-11=665/731
 BOT CHORD 2-18=145/1682, 16-18=0/1525, 14-16=74/1889, 13-14=633/691, 11-13=633/691
 WEBS 10-14=293/1592, 5-18=0/802, 7-16=0/800, 5-7=1276/319, 9-16=656/197,
 10-13=1719/489

- NOTES-**
- Unbalanced roof live loads have been considered for this design.
 - Wind: ASCE 7-10; Vult=130mph Vasd=103mph; TCDL=6.0psf; BCDL=6.0psf; h=15ft; Cat. II; Exp C; Enclosed; MWFRS (envelope) and C-C Exterior(2) -0-9-1 to 3-7-12, Interior(1) 3-7-12 to 14-10-4, Exterior(2) 14-10-4 to 19-3-1, Interior(1) 19-3-1 to 39-3-8 zone; cantilever right exposed ;C-C for members and forces & MWFRS for reactions shown; Lumber DOL=1.60 plate grip DOL=1.60
 - This truss has been designed for a 10.0 psf bottom chord live load nonconcurrent with any other live loads.
 - * This truss has been designed for a live load of 30.0psf on the bottom chord in all areas where a rectangle 3-6-0 tall by 2-0-0 wide will fit between the bottom chord and any other members, with BCDL = 10.0psf.
 - Provide mechanical connection (by others) of truss to bearing plate capable of withstanding 66 lb uplift at joint 2 and 177 lb uplift at joint 13.
 - Graphical purlin representation does not depict the size or the orientation of the purlin along the top and/or bottom chord.

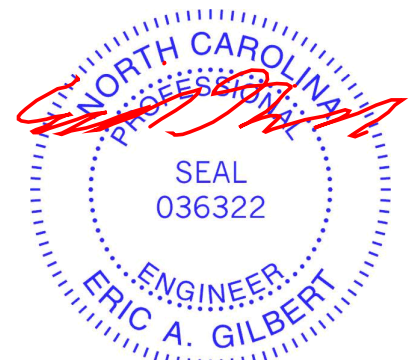

April 17, 2024

Job J0424-2222	Truss B1	Truss Type FINK	Qty 4	Ply 1	Wellco/Lot 10 Overhills Creek/Harnett Job Reference (optional)	I64935116
-------------------	-------------	--------------------	----------	----------	---	-----------

Comtech, Inc. Fayetteville, NC - 28314,

8.430 s Jan 6 2022 MiTek Industries, Inc. Tue Apr 16 10:01:10 2024 Page 1

ID:Yb7beGiAPPG119hcv?SQQjyfOh?-RfC?PsB70Hq3NSgPqnL8w3ulTXbGKWrCDoi7J4zJC?f



5x5 =

Scale = 1:76.2

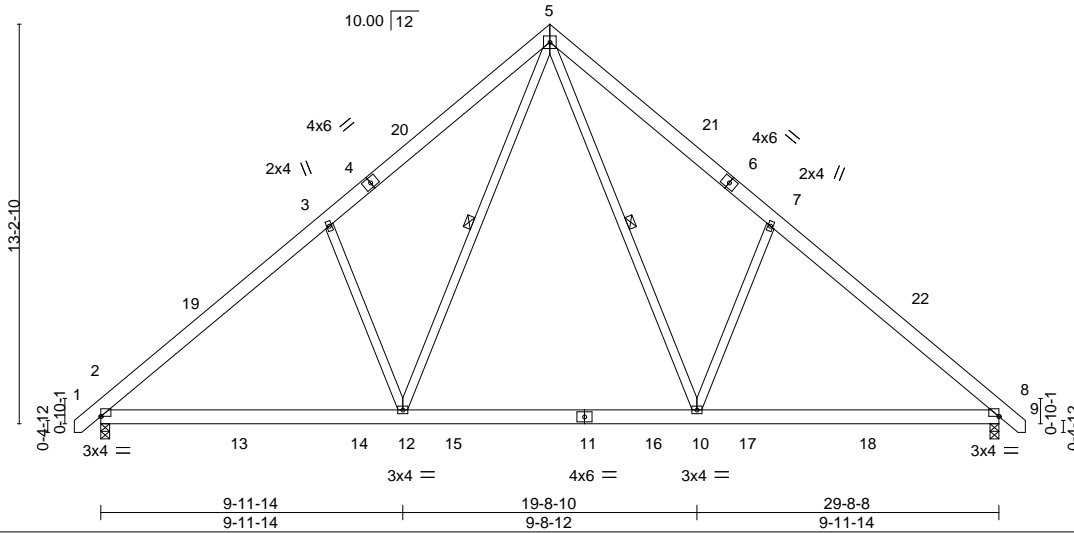

LOADING (psf)	SPACING-	2-0-0	CSI.	DEFL.	in (loc)	l/defl	L/d	PLATES	GRIP
TCLL 20.0	Plate Grip DOL	1.15	TC 0.24	Vert(LL)	-0.11 10-12	>999	360	MT20	244/190
TCDL 10.0	Lumber DOL	1.15	BC 0.47	Vert(CT)	-0.16 8-10	>999	240		
BCLL 0.0 *	Rep Stress Incr	YES	WB 0.43	Horz(CT)	0.03 8	n/a	n/a		
BCDL 10.0	Code IRC2015/TPI2014		Matrix-S	Wind(LL)	0.04 2-12	>999	240	Weight: 225 lb	FT = 20%

LUMBER-
TOP CHORD 2x6 SP No.1
BOT CHORD 2x6 SP No.1
WEBS 2x4 SP No.2

BRACING-
TOP CHORD Structural wood sheathing directly applied or 5-8-8 oc purlins.
BOT CHORD Rigid ceiling directly applied or 10-0-0 oc bracing.
WEBS 1 Row at midpt 5-12, 5-10

REACTIONS. (size) 2=0-3-8, 8=0-3-8
Max Horz 2=312(LC 11)
Max Uplift 2=62(LC 12), 8=62(LC 13)
Max Grav 2=1454(LC 19), 8=1454(LC 20)

FORCES. (lb) - Max. Comp./Max. Ten. - All forces 250 (lb) or less except when shown.
TOP CHORD 2-3=-1764/326, 3-5=-1663/496, 5-7=-1664/496, 7-8=-1764/326
BOT CHORD 2-12=-101/1448, 10-12=0/951, 8-10=-87/1286
WEBS 3-12=-523/348, 5-12=-223/965, 5-10=-223/965, 7-10=-523/348

- NOTES-**
- 1) Unbalanced roof live loads have been considered for this design.
 - 2) Wind: ASCE 7-10; Vult=130mph Vasd=103mph; TC DL=6.0psf; BCDL=6.0psf; h=15ft; Cat. II; Exp C; Enclosed; MWFRS (envelope) and C-C Exterior(2) -0-9-1 to 3-7-12, Interior(1) 3-7-12 to 14-10-4, Exterior(2) 14-10-4 to 19-3-1, Interior(1) 19-3-1 to 30-5-9 zone; C-C for members and forces & MWFRS for reactions shown; Lumber DOL=1.60 plate grip DOL=1.60
 - 3) This truss has been designed for a 10.0 psf bottom chord live load nonconcurrent with any other live loads.
 - 4) * This truss has been designed for a live load of 30.0psf on the bottom chord in all areas where a rectangle 3-6-0 tall by 2-0-0 wide will fit between the bottom chord and any other members, with BCDL = 10.0psf.
 - 5) Provide mechanical connection (by others) of truss to bearing plate capable of withstanding 62 lb uplift at joint 2 and 62 lb uplift at joint 8.



April 17, 2024

WARNING - Verify design parameters and READ NOTES ON THIS AND INCLUDED MITEK REFERENCE PAGE MII-7473 rev. 1/2/2023 BEFORE USE.
Design valid for use only with MiTek® connectors. This design is based only upon parameters shown, and is for an individual building component, not a truss system. Before use, the building designer must verify the applicability of design parameters and properly incorporate this design into the overall building design. Bracing indicated is to prevent buckling of individual truss web and/or chord members only. Additional temporary and permanent bracing is always required for stability and to prevent collapse with possible personal injury and property damage. For general guidance regarding the fabrication, storage, delivery, erection and bracing of trusses and truss systems, see **ANSI/TPH Quality Criteria and DSB-22** available from Truss Plate Institute (www.tpinst.org) and **BCSI Building Component Safety Information** available from the Structural Building Component Association (www.sbcacomponents.com)



Job J0424-2222	Truss B1GE	Truss Type GABLE	Qty 1	Ply 1	Wellco/Lot 10 Overhills Creek/Harnett Job Reference (optional)	164935117
-------------------	---------------	---------------------	----------	----------	---	-----------

Comtech, Inc. Fayetteville, NC - 28314,

8.430 s Jan 6 2022 MiTek Industries, Inc. Tue Apr 16 10:01:10 2024 Page 1

ID:Yb7beGiAPPG119hcw?SQQjyfOh?-RfC?PsB70Hq3NSgPqnL8w3ulTXbGKWrCDoi7J4zJC?f

-0-10-8 14-10-4 29-8-8 30-7-0
0-10-8 14-10-4 14-10-4 0-10-8

5x5 =

Scale = 1:82.1

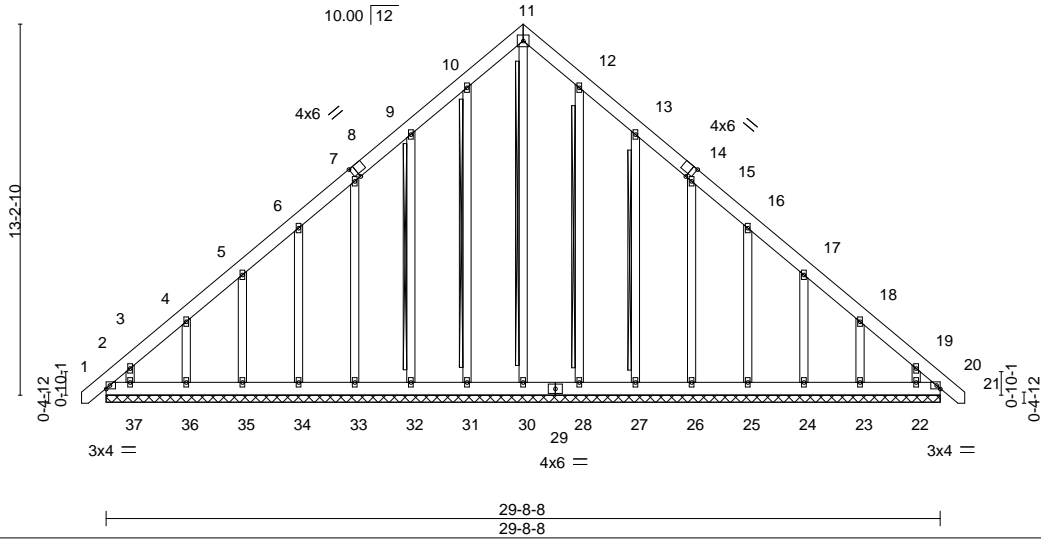

Plate Offsets (X, Y)--	[8:0-2-0,Edge], [14:0-2-0,Edge]				
LOADING (psf)	SPACING- 2-0-0	CSI.	DEFL. in (loc) l/defl L/d	PLATES	GRIP
TCLL 20.0	Plate Grip DOL 1.15	TC 0.06	Vert(LL) 0.00 20 n/r 120	MT20	244/190
TCDL 10.0	Lumber DOL 1.15	BC 0.04	Vert(CT) 0.00 20 n/r 120		
BCLL 0.0 *	Rep Stress Incr YES	WB 0.22	Horz(CT) 0.01 20 n/a n/a		
BCDL 10.0	Code IRC2015/TP12014	Matrix-S			
				Weight: 301 lb	FT = 20%

LUMBER-	BRACING-	
TOP CHORD 2x6 SP No.1	TOP CHORD Structural wood sheathing directly applied or 6-0-0 oc purlins.	
BOT CHORD 2x6 SP No.1	BOT CHORD Rigid ceiling directly applied or 10-0-0 oc bracing.	
OTHERS 2x4 SP No.2	WEBS T-Brace: 2x4 SPF No.2 - 11-30, 10-31, 9-32, 12-28, 13-27	
	Fasten (2X) T and I braces to narrow edge of web with 10d (0.131"x3") nails, 6in o.c., with 3in minimum end distance. Brace must cover 90% of web length.	

REACTIONS. All bearings 29-8-8.
 (lb) - Max Horz 2=390(LC 11)
 Max Uplift All uplift 100 lb or less at joint(s) 31, 28 except 2=222(LC 10), 20=130(LC 11), 32=126(LC 12), 33=112(LC 12), 34=110(LC 12), 35=109(LC 12), 36=121(LC 12), 37=204(LC 12), 27=130(LC 13), 26=112(LC 13), 25=110(LC 13), 24=109(LC 13), 23=120(LC 13), 22=187(LC 13)
 Max Grav All reactions 250 lb or less at joint(s) 31, 32, 33, 34, 35, 36, 37, 28, 27, 26, 25, 24, 23, 22 except 2=402(LC 12), 20=340(LC 13), 30=270(LC 13)

FORCES. (lb) - Max. Comp./Max. Ten. - All forces 250 (lb) or less except when shown.
 TOP CHORD 2-3=-554/341, 3-4=-409/278, 4-5=-301/236, 9-10=-224/264, 10-11=-267/296, 11-12=-267/296, 18-19=-341/221, 19-20=-476/326
 BOT CHORD 2-37=-230/351, 36-37=-230/351, 35-36=-230/351, 34-35=-230/351, 33-34=-230/351, 32-33=-230/351, 31-32=-230/351, 30-31=-230/351, 28-30=-230/351, 27-28=-230/351, 26-27=-230/351, 25-26=-230/351, 24-25=-230/351, 23-24=-230/351, 22-23=-230/351, 20-22=-230/351
 WEBS 11-30=-253/172

- NOTES-**
- Unbalanced roof live loads have been considered for this design.
 - Wind: ASCE 7-10; Vult=130mph Vasd=103mph; TCDL=6.0psf; BCDL=6.0psf; h=15ft; Cat. II; Exp C; Enclosed; MWFRS (envelope) gable end zone and C-C Corner(3) 0-9-1 to 3-7-12, Exterior(2) 3-7-12 to 14-10-4, Corner(3) 14-10-4 to 19-3-1, Exterior(2) 19-3-1 to 30-5-9 zone; C-C for members and forces & MWFRS for reactions shown; Lumber DOL=1.60 plate grip DOL=1.60
 - Truss designed for wind loads in the plane of the truss only. For studs exposed to wind (normal to the face), see Standard Industry Gable End Details as applicable, or consult qualified building designer as per ANSI/TP1.
 - All plates are 2x4 MT20 unless otherwise indicated.
 - Gable requires continuous bottom chord bearing.
 - Gable studs spaced at 2-0-0 oc.
 - This truss has been designed for a 10.0 psf bottom chord live load nonconcurrent with any other live loads.
 - * This truss has been designed for a live load of 30.0psf on the bottom chord in all areas where a rectangle 3-6-0 tall by 2-0-0 wide will fit between the bottom chord and any other members.
 - Provide mechanical connection (by others) of truss to bearing plate capable of withstanding 100 lb uplift at joint(s) 31, 28 except (jt=lb) 2=222, 20=130, 32=126, 33=112, 34=110, 35=109, 36=121, 37=204, 27=130, 26=112, 25=110, 24=109, 23=120, 22=187.
 - Warning: Additional permanent and stability bracing for truss system (not part of this component design) is always required.

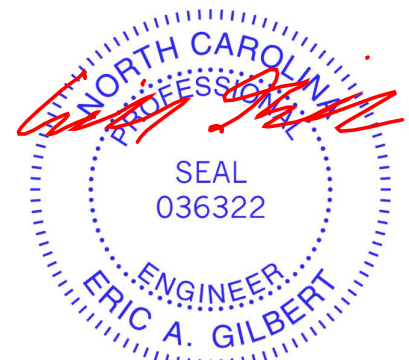

April 17, 2024

<p>WARNING - Verify design parameters and READ NOTES ON THIS AND INCLUDED MITEK REFERENCE PAGE MII-7473 rev. 1/2/2023 BEFORE USE.</p> <p>Design valid for use only with MiTek® connectors. This design is based only upon parameters shown, and is for an individual building component, not a truss system. Before use, the building designer must verify the applicability of design parameters and properly incorporate this design into the overall building design. Bracing indicated is to prevent buckling of individual truss web and/or chord members only. Additional temporary and permanent bracing is always required for stability and to prevent collapse with possible personal injury and property damage. For general guidance regarding the fabrication, storage, delivery, erection and bracing of trusses and truss systems, see ANSI/TP1 Quality Criteria and DSB-22 available from Truss Plate Institute (www.tpinst.org) and BCSI Building Component Safety Information available from the Structural Building Component Association (www.sbcacomponents.com)</p>	<p>ENGINEERING BY TRENCO A MITEK Affiliate</p> <p>818 Soundside Road Edenton, NC 27932</p>
--	--

Job J0424-2222	Truss B2	Truss Type ROOF SPECIAL	Qty 2	Ply 1	Wellco/Lot 10 Overhills Creek/Harnett Job Reference (optional)	164935118
-------------------	-------------	----------------------------	----------	----------	---	-----------

Comtech, Inc. Fayetteville, NC - 28314,

8.430 s Jan 6 2022 MiTek Industries, Inc. Tue Apr 16 10:01:11 2024 Page 1

ID:Yb7beGiAPPG119hcw?SQjyfOh?-RfC?PsB70Hq3NSgPqnL8w3uITXbGKWrCDoi7J4zJC?f



5x5 =

Scale = 1:76.2

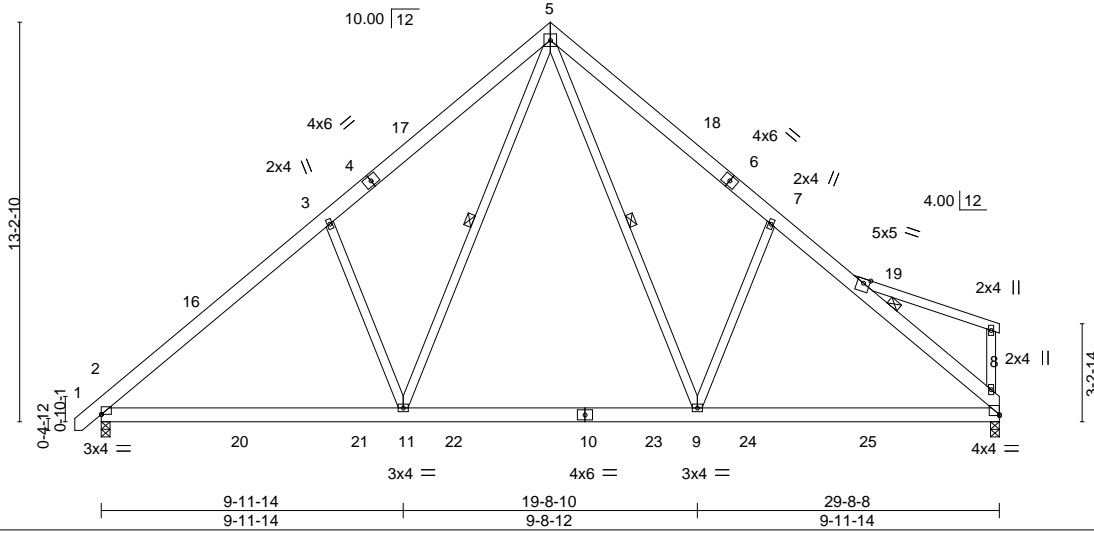

Plate Offsets (X,Y)--	[8:0-0-0,0-0-7]								
LOADING (psf)	SPACING-	2-0-0	CSI.	DEFL.	in (loc)	l/defl	L/d	PLATES	GRIP
TCLL 20.0	Plate Grip DOL	1.15	TC 0.68	Vert(LL)	-0.11	9-11	>999	MT20	244/190
TCDL 10.0	Lumber DOL	1.15	BC 0.48	Vert(CT)	-0.16	8-9	>999		
BCLL 0.0 *	Rep Stress Incr	YES	WB 0.43	Horz(CT)	0.03	8	n/a		
BCDL 10.0	Code IRC2015/TPI2014		Matrix-S	Wind(LL)	0.04	2-11	>999	Weight: 233 lb	FT = 20%

LUMBER-	BRACING-
TOP CHORD 2x6 SP No.1 *Except* 13-15: 2x4 SP No.1	TOP CHORD Structural wood sheathing directly applied or 5-8-7 oc purlins, except end verticals. Except: 5-8-0 oc bracing: 7-8
BOT CHORD 2x6 SP No.1	BOT CHORD Rigid ceiling directly applied or 10-0-0 oc bracing.
WEBS 2x4 SP No.2	WEBS 1 Row at midpt 5-11, 5-9

REACTIONS. (size) 2=0-3-8, 8=0-3-8
Max Horz 2=309(LC 11)
Max Uplift 2=-62(LC 12), 8=-49(LC 13)
Max Grav 2=1454(LC 19), 8=1403(LC 20)

FORCES. (lb) - Max. Comp./Max. Ten. - All forces 250 (lb) or less except when shown.
TOP CHORD 2-3=-1765/327, 3-5=-1664/497, 5-7=-1667/507, 7-8=-1766/332
BOT CHORD 2-11=-106/1445, 9-11=0/948, 8-9=-99/1284
WEBS 3-11=-523/348, 5-11=-224/964, 5-9=-225/969, 7-9=-525/353

- NOTES-**
- 1) Unbalanced roof live loads have been considered for this design.
 - 2) Wind: ASCE 7-10; Vult=130mph Vasd=103mph; TCDL=6.0psf; BCDL=6.0psf; h=15ft; Cat. II; Exp C; Enclosed; MWFRS (envelope) and C-C Exterior(2) -0-9-1 to 3-7-12, Interior(1) 3-7-12 to 14-10-4, Exterior(2) 14-10-4 to 19-3-1, Interior(1) 19-3-1 to 29-6-12 zone;C-C for members and forces & MWFRS for reactions shown; Lumber DOL=1.60 plate grip DOL=1.60
 - 3) This truss has been designed for a 10.0 psf bottom chord live load nonconcurrent with any other live loads.
 - 4) * This truss has been designed for a live load of 30.0psf on the bottom chord in all areas where a rectangle 3-6-0 tall by 2-0-0 wide will fit between the bottom chord and any other members, with BCDL = 10.0psf.
 - 5) Provide mechanical connection (by others) of truss to bearing plate capable of withstanding 100 lb uplift at joint(s) 2, 8.
 - 6) Graphical purlin representation does not depict the size or the orientation of the purlin along the top and/or bottom chord.



April 17, 2024

<p>WARNING - Verify design parameters and READ NOTES ON THIS AND INCLUDED MITEK REFERENCE PAGE MII-7473 rev. 1/2/2023 BEFORE USE.</p> <p>Design valid for use only with MiTek® connectors. This design is based only upon parameters shown, and is for an individual building component, not a truss system. Before use, the building designer must verify the applicability of design parameters and properly incorporate this design into the overall building design. Bracing indicated is to prevent buckling of individual truss web and/or chord members only. Additional temporary and permanent bracing is always required for stability and to prevent collapse with possible personal injury and property damage. For general guidance regarding the fabrication, storage, delivery, erection and bracing of trusses and truss systems, see ANSI/TPH Quality Criteria and DSB-22 available from Truss Plate Institute (www.tpinst.org) and BCSI Building Component Safety Information available from the Structural Building Component Association (www.sbcacomponents.com)</p>	<p>ENGINEERING BY</p> <p>TRENCO</p> <p>A MiTek Affiliate</p> <p>818 Soundside Road Edenton, NC 27932</p>
--	---

Job J0424-2222	Truss B3	Truss Type FINK	Qty 6	Ply 1	Wellco/Lot 10 Overhills Creek/Harnett 164935119
-------------------	-------------	--------------------	----------	----------	--

Comtech, Inc. Fayetteville, NC - 28314,

8.430 s Jan 6 2022 MiTek Industries, Inc. Tue Apr 16 10:01:12 2024 Page 1

ID:Yb7beGiAPPG119hcv?SQjyfOh?-RfC?PsB70Hq3NSgPqnL8w3uITXbGKWrCDoi7J4zJC?f



5x5 =

Scale = 1:76.2

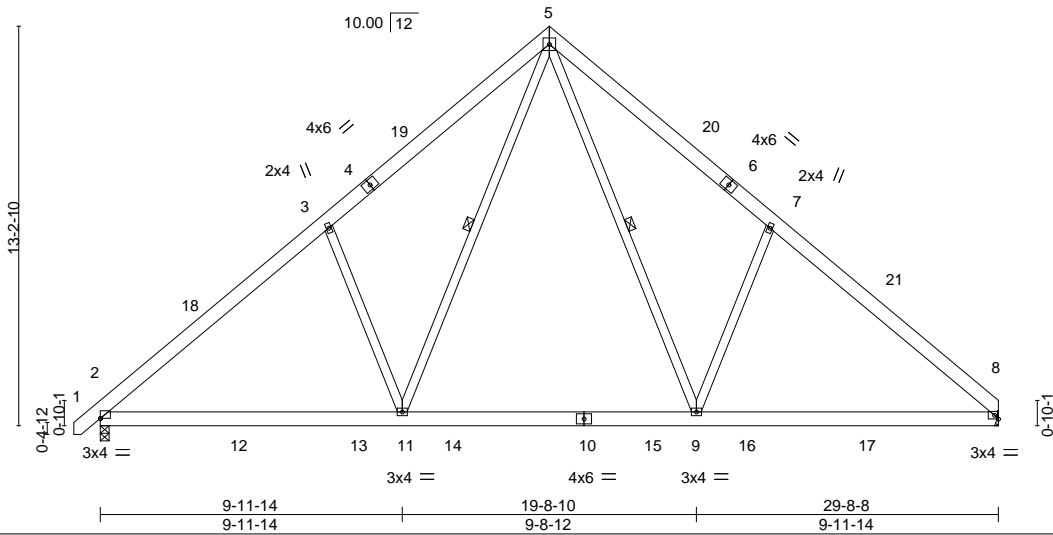

LOADING (psf)	SPACING-	2-0-0	CSI.	DEFL.	in (loc)	l/defl	L/d	PLATES	GRIP
TCLL 20.0	Plate Grip DOL	1.15	TC 0.25	Vert(LL)	-0.11 9-11	>999	360	MT20	244/190
TCDL 10.0	Lumber DOL	1.15	BC 0.48	Vert(CT)	-0.17 8-9	>999	240		
BCLL 0.0 *	Rep Stress Incr	YES	WB 0.44	Horz(CT)	0.03 8	n/a	n/a		
BCDL 10.0	Code IRC2015/TPI2014		Matrix-S	Wind(LL)	0.04 2-11	>999	240		
								Weight: 222 lb	FT = 20%

LUMBER-	BRACING-
TOP CHORD 2x6 SP No.1	TOP CHORD Structural wood sheathing directly applied or 5-7-11 oc purlins.
BOT CHORD 2x6 SP No.1	BOT CHORD Rigid ceiling directly applied or 10-0-0 oc bracing.
WEBS 2x4 SP No.2	WEBS 1 Row at midpt 5-11, 5-9

REACTIONS. (size) 2=0-3-8, 8=Mechanical
 Max Horz 2=309(LC 9)
 Max Uplift 2=-62(LC 12), 8=-50(LC 13)
 Max Grav 2=1458(LC 19), 8=1405(LC 20)

FORCES. (lb) - Max. Comp./Max. Ten. - All forces 250 (lb) or less except when shown.
 TOP CHORD 2-3=-1771/328, 3-5=-1670/498, 5-7=-1680/508, 7-8=-1777/333
 BOT CHORD 2-11=-106/1449, 9-11=0/952, 8-9=-101/1298
 WEBS 3-11=-523/348, 5-11=-224/964, 5-9=-227/983, 7-9=-535/356

NOTES-

- 1) Unbalanced roof live loads have been considered for this design.
- 2) Wind: ASCE 7-10; Vult=130mph Vasd=103mph; TC DL=6.0psf; BCDL=6.0psf; h=15ft; Cat. II; Exp C; Enclosed; MWFRS (envelope) and C-C Exterior(2) -0-9-1 to 3-7-12, Interior(1) 3-7-12 to 14-10-4, Exterior(2) 14-10-4 to 19-3-1, Interior(1) 19-3-1 to 29-7-12 zone; C-C for members and forces & MWFRS for reactions shown; Lumber DOL=1.60 plate grip DOL=1.60
- 3) This truss has been designed for a 10.0 psf bottom chord live load nonconcurrent with any other live loads.
- 4) * This truss has been designed for a live load of 30.0psf on the bottom chord in all areas where a rectangle 3-6-0 tall by 2-0-0 wide will fit between the bottom chord and any other members, with BCDL = 10.0psf.
- 5) Refer to girder(s) for truss to truss connections.
- 6) Provide mechanical connection (by others) of truss to bearing plate capable of withstanding 100 lb uplift at joint(s) 2, 8.

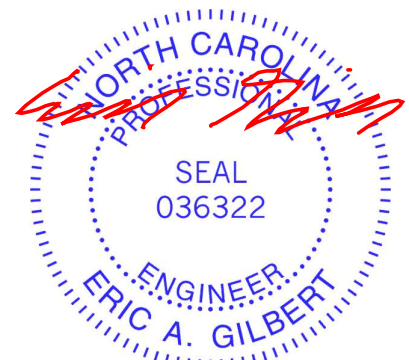

April 17, 2024

<p>WARNING - Verify design parameters and READ NOTES ON THIS AND INCLUDED MITEK REFERENCE PAGE MII-7473 rev. 1/2/2023 BEFORE USE.</p> <p>Design valid for use only with MiTek® connectors. This design is based only upon parameters shown, and is for an individual building component, not a truss system. Before use, the building designer must verify the applicability of design parameters and properly incorporate this design into the overall building design. Bracing indicated is to prevent buckling of individual truss web and/or chord members only. Additional temporary and permanent bracing is always required for stability and to prevent collapse with possible personal injury and property damage. For general guidance regarding the fabrication, storage, delivery, erection and bracing of trusses and truss systems, see ANSI/TPH Quality Criteria and DSB-22 available from Truss Plate Institute (www.tpinst.org) and BCSI Building Component Safety Information available from the Structural Building Component Association (www.sbcacomponents.com)</p>	 <p>818 Soundside Road Edenton, NC 27932</p>
--	---

Job J0424-2222	Truss B3GE	Truss Type GABLE	Qty 1	Ply 1	Wellco/Lot 10 Overhills Creek/Harnett Job Reference (optional)	164935120
-------------------	---------------	---------------------	----------	----------	---	-----------

Comtech, Inc. Fayetteville, NC - 28314,

8.430 s Jan 6 2022 MiTek Industries, Inc. Tue Apr 16 10:01:12 2024 Page 1

ID:Y7beGiAPPG119hcw?SQQjyfOh?-RfC?PsB70Hq3NSgPqnL8w3uITXbGKWrCDoi7J4zJC?f

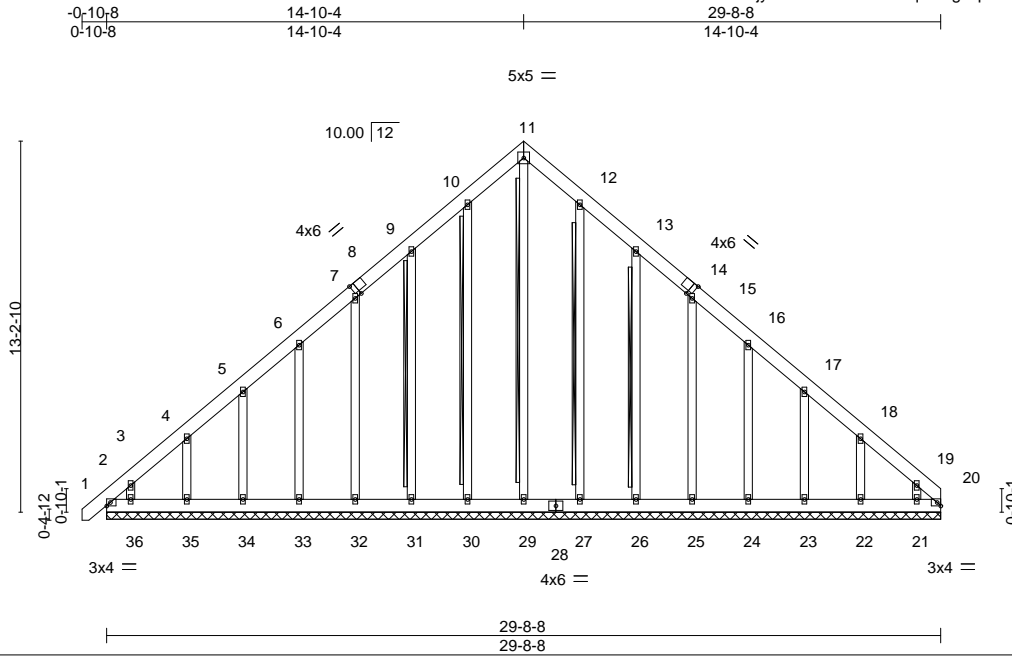

Scale = 1:82.1

Plate Offsets (X, Y)--	[8:0-2-0,Edge], [14:0-2-0,Edge]				
LOADING (psf)	SPACING- 2-0-0	CSI.	DEFL. in (loc) l/defl L/d	PLATES	GRIP
TCLL 20.0	Plate Grip DOL 1.15	TC 0.06	Vert(LL) -0.00 1 n/r 120	MT20	244/190
TCDL 10.0	Lumber DOL 1.15	BC 0.04	Vert(CT) -0.00 1 n/r 120		
BCLL 0.0 *	Rep Stress Incr YES	WB 0.22	Horz(CT) 0.01 20 n/a n/a		
BCDL 10.0	Code IRC2015/TPI2014	Matrix-S		Weight: 299 lb	FT = 20%

LUMBER-	BRACING-
TOP CHORD 2x6 SP No.1	TOP CHORD Structural wood sheathing directly applied or 6-0-0 oc purlins.
BOT CHORD 2x6 SP No.1	BOT CHORD Rigid ceiling directly applied or 10-0-0 oc bracing.
OTHERS 2x4 SP No.2	WEBS T-Brace: 2x4 SPF No.2 - 11-29, 10-30, 9-31, 12-27, 13-26
	Fasten (2X) T and I braces to narrow edge of web with 10d (0.131"x3") nails, 6in o.c., with 3in minimum end distance. Brace must cover 90% of web length.

REACTIONS. All bearings 29-8-8.
 (lb) - Max Horz 2=387(LC 9)
 Max Uplift All uplift 100 lb or less at joint(s) 30, 27 except 2=-221(LC 10), 20=-166(LC 11), 31=-126(LC 12), 32=-112(LC 12), 33=-110(LC 12), 34=-109(LC 12), 35=-121(LC 12), 36=-204(LC 12), 26=-130(LC 13), 25=-112(LC 13), 24=-110(LC 13), 23=-109(LC 13), 22=-119(LC 13), 21=-201(LC 13)
 Max Grav All reactions 250 lb or less at joint(s) 30, 31, 32, 33, 34, 35, 36, 27, 26, 25, 24, 23, 22, 21 except 2=403(LC 12), 20=377(LC 13), 29=266(LC 13)

FORCES. (lb) - Max. Comp./Max. Ten. - All forces 250 (lb) or less except when shown.
 TOP CHORD 2-3=-556/339, 3-4=-411/277, 4-5=-302/234, 9-10=-222/260, 10-11=-265/291, 11-12=-265/291, 18-19=-344/219, 19-20=-489/325
 BOT CHORD 2-36=-222/341, 35-36=-222/341, 34-35=-222/341, 33-34=-222/341, 32-33=-222/341, 31-32=-222/341, 30-31=-222/341, 29-30=-222/341, 27-29=-222/341, 26-27=-222/341, 25-26=-222/341, 24-25=-222/341, 23-24=-222/341, 22-23=-222/341, 21-22=-222/341, 20-21=-222/340

- NOTES-**
- Unbalanced roof live loads have been considered for this design.
 - Wind: ASCE 7-10; Vult=130mph Vasd=103mph; TCDL=6.0psf; BCDL=6.0psf; h=15ft; Cat. II; Exp C; Enclosed; MWFRS (envelope) gable end zone and C-C Corner(3) 0-9-1 to 3-7-12, Exterior(2) 3-7-12 to 14-10-4, Corner(3) 14-10-4 to 19-3-1, Exterior(2) 19-3-1 to 29-8-8 zone; C-C for members and forces & MWFRS for reactions shown; Lumber DOL=1.60 plate grip DOL=1.60
 - Truss designed for wind loads in the plane of the truss only. For studs exposed to wind (normal to the face), see Standard Industry Gable End Details as applicable, or consult qualified building designer as per ANSI/TPI 1.
 - All plates are 2x4 MT20 unless otherwise indicated.
 - Gable requires continuous bottom chord bearing.
 - Gable studs spaced at 2-0-0 oc.
 - This truss has been designed for a 10.0 psf bottom chord live load nonconcurrent with any other live loads.
 - * This truss has been designed for a live load of 30.0psf on the bottom chord in all areas where a rectangle 3-6-0 tall by 2-0-0 wide will fit between the bottom chord and any other members.
 - Provide mechanical connection (by others) of truss to bearing plate capable of withstanding 100 lb uplift at joint(s) 30, 27 except (jt=lb) 2=221, 20=166, 31=126, 32=112, 33=110, 34=109, 35=121, 36=204, 26=130, 25=112, 24=110, 23=109, 22=119, 21=201.
 - Warning: Additional permanent and stability bracing for truss system (not part of this component design) is always required.

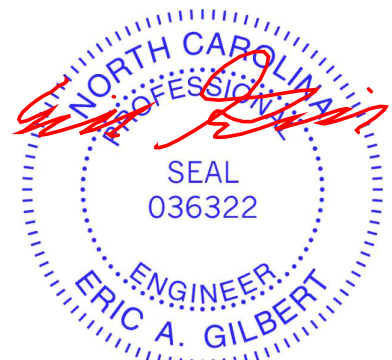

April 17, 2024

WARNING - Verify design parameters and READ NOTES ON THIS AND INCLUDED MITEK REFERENCE PAGE MII-7473 rev. 1/2/2023 BEFORE USE.

Design valid for use only with MiTek® connectors. This design is based only upon parameters shown, and is for an individual building component, not a truss system. Before use, the building designer must verify the applicability of design parameters and properly incorporate this design into the overall building design. Bracing indicated is to prevent buckling of individual truss web and/or chord members only. Additional temporary and permanent bracing is always required for stability and to prevent collapse with possible personal injury and property damage. For general guidance regarding the fabrication, storage, delivery, erection and bracing of trusses and truss systems, see **ANSI/TPI Quality Criteria and DSB-22** available from Truss Plate Institute (www.tpinst.org) and **BCSI Building Component Safety Information** available from the Structural Building Component Association (www.sbcacomponents.com)

TRENCO
ENGINEERING BY
A MiTek Affiliate

818 Soundside Road
Edenton, NC 27932

Job J0424-2222	Truss B4	Truss Type COMMON	Qty 3	Ply 1	Wellco/Lot 10 Overhills Creek/Harnett Job Reference (optional)	164935121
-------------------	-------------	----------------------	----------	----------	---	-----------

Comtech, Inc. Fayetteville, NC - 28314,

8.430 s Jan 6 2022 MiTek Industries, Inc. Tue Apr 16 10:01:13 2024 Page 1

ID:Yb7beGiAPPG119hcw?SQQjyfOh?-RfC?PsB70Hq3NSgPqnL8w3ulTXbGKWrCDoi7J4zJC?f

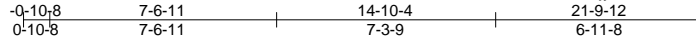

5x5 =

Scale = 1:76.8

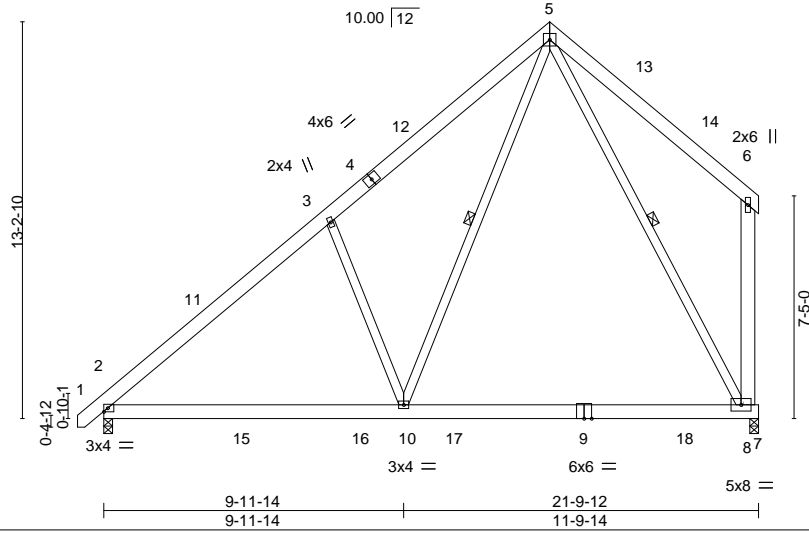

LOADING (psf)	SPACING-	2-0-0	CSI.	DEFL.	in (loc)	l/defl	L/d	PLATES	GRIP
TCLL 20.0	Plate Grip DOL	1.15	TC 0.38	Vert(LL)	-0.27 8-10	>963	360	MT20	244/190
TCDL 10.0	Lumber DOL	1.15	BC 0.60	Vert(CT)	-0.36 8-10	>714	240		
BCLL 0.0 *	Rep Stress Incr	YES	WB 0.71	Horz(CT)	0.01 8	n/a	n/a		
BCDL 10.0	Code IRC2015/TPI2014		Matrix-S	Wind(LL)	0.03 2-10	>999	240		
								Weight: 187 lb	FT = 20%

LUMBER-
 TOP CHORD 2x6 SP No.1
 BOT CHORD 2x6 SP No.1
 WEBS 2x4 SP No.2 *Except*
 6-8: 2x6 SP No.1

BRACING-
 TOP CHORD Structural wood sheathing directly applied or 6-0-0 oc purlins, except end verticals.
 BOT CHORD Rigid ceiling directly applied or 10-0-0 oc bracing.
 WEBS 1 Row at midpt 5-10, 5-8

REACTIONS. (size) 8=0-3-8, 2=0-3-8
 Max Horz 2=308(LC 12)
 Max Uplift 8=90(LC 12), 2=-22(LC 12)
 Max Grav 8=1128(LC 19), 2=1061(LC 19)

FORCES. (lb) - Max. Comp./Max. Ten. - All forces 250 (lb) or less except when shown.
 TOP CHORD 2-3=-1193/169, 3-5=-1108/341, 6-8=-290/193
 BOT CHORD 2-10=-252/973, 8-10=-54/424
 WEBS 3-10=-539/351, 5-10=-200/1092, 5-8=-792/110

NOTES-

- 1) Unbalanced roof live loads have been considered for this design.
- 2) Wind: ASCE 7-10; Vult=130mph Vasd=103mph; TCDL=6.0psf; BCDL=6.0psf; h=15ft; Cat. II; Exp C; Enclosed; MWFRS (envelope) and C-C Exterior(2) -0-9-1 to 3-7-12, Interior(1) 3-7-12 to 14-10-4, Exterior(2) 14-10-4 to 19-3-1, Interior(1) 19-3-1 to 21-5-8 zone;C-C for members and forces & MWFRS for reactions shown; Lumber DOL=1.60 plate grip DOL=1.60
- 3) This truss has been designed for a 10.0 psf bottom chord live load nonconcurrent with any other live loads.
- 4) * This truss has been designed for a live load of 30.0psf on the bottom chord in all areas where a rectangle 3-6-0 tall by 2-0-0 wide will fit between the bottom chord and any other members, with BCDL = 10.0psf.
- 5) Provide mechanical connection (by others) of truss to bearing plate capable of withstanding 100 lb uplift at joint(s) 8, 2.

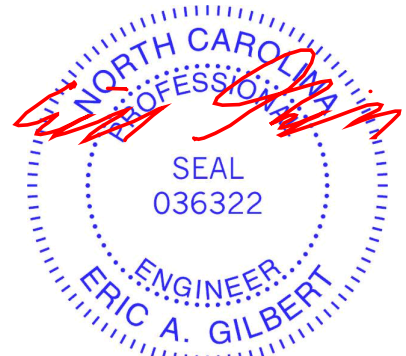

April 17, 2024

WARNING - Verify design parameters and READ NOTES ON THIS AND INCLUDED MITEK REFERENCE PAGE MII-7473 rev. 1/2/2023 BEFORE USE.

Design valid for use only with MiTek® connectors. This design is based only upon parameters shown, and is for an individual building component, not a truss system. Before use, the building designer must verify the applicability of design parameters and properly incorporate this design into the overall building design. Bracing indicated is to prevent buckling of individual truss web and/or chord members only. Additional temporary and permanent bracing is always required for stability and to prevent collapse with possible personal injury and property damage. For general guidance regarding the fabrication, storage, delivery, erection and bracing of trusses and truss systems, see **ANSI/TP1 Quality Criteria and DSB-22** available from Truss Plate Institute (www.tpinst.org) and **BCSI Building Component Safety Information** available from the Structural Building Component Association (www.sbcacomponents.com)



818 Soundside Road
 Edenton, NC 27932

Job J0424-2222	Truss C1	Truss Type ROOF TRUSS	Qty 6	Ply 1	Wellco/Lot 10 Overhills Creek/Harnett Job Reference (optional)	I64935122
-------------------	-------------	--------------------------	----------	----------	---	-----------

Comtech, Inc. Fayetteville, NC - 28314,

8.430 s Jan 6 2022 MiTek Industries, Inc. Tue Apr 16 10:01:13 2024 Page 1

ID:Yb7beGiAPPG119hcw?SQQjyfOh?-RfC?PsB70Hq3NSgPqnL8w3uITXbGKWrCDoi7J4zJC?f

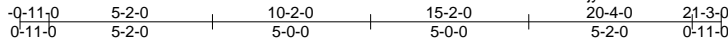

6x8 =

Scale = 1:72.8

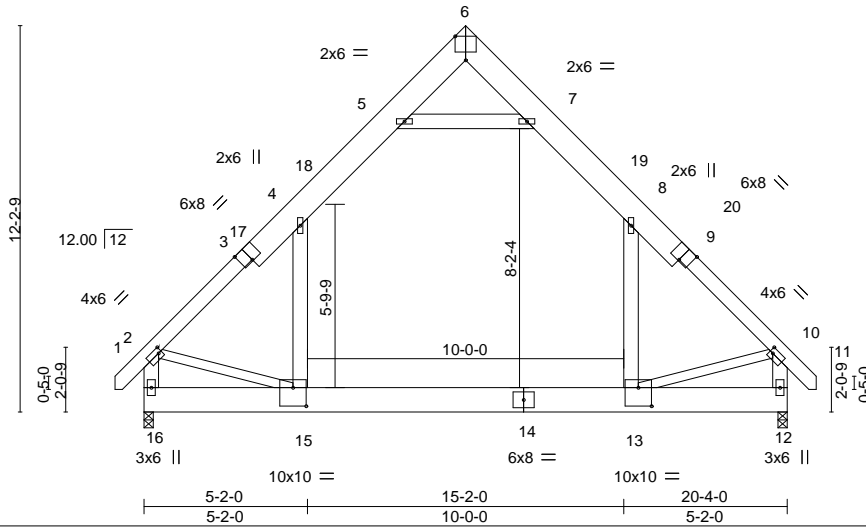

Plate Offsets (X,Y)--	[2:0-1-4,0-2-0], [3:0-4-0,Edge], [6:0-4-0,Edge], [9:0-4-0,Edge], [10:0-1-4,0-2-0], [13:0-5-0,0-7-0], [15:0-5-0,0-7-0]
-----------------------	---

LOADING (psf)	SPACING-	2-0-0	CSI.	DEFL.	in (loc)	l/defl	L/d	PLATES	GRIP
TCLL 20.0	Plate Grip DOL	1.15	TC 0.36	Vert(LL)	-0.10 13-15	>999	360	MT20	244/190
TCDL 10.0	Lumber DOL	1.15	BC 0.50	Vert(CT)	-0.16 13-15	>999	240		
BCLL 0.0 *	Rep Stress Incr	YES	WB 0.18	Horz(CT)	0.01 12	n/a	n/a		
BCDL 10.0	Code IRC2015/TPI2014		Matrix-S	Wind(LL)	0.03 15	>999	240		
								Weight: 240 lb	FT = 20%

LUMBER-	BRACING-
TOP CHORD 2x6 SP No.1 *Except* 3-6,6-9: 2x10 SP No.1	TOP CHORD Structural wood sheathing directly applied or 5-11-14 oc purlins, except end verticals.
BOT CHORD 2x10 SP No.1	BOT CHORD Rigid ceiling directly applied or 10-0-0 oc bracing.
WEBS 2x6 SP No.1 *Except* 2-15,10-13: 2x4 SP No.2	

REACTIONS. (size) 16=0-3-8, 12=0-3-8
 Max Horz 16=312(LC 10)
 Max Grav 16=1352(LC 21), 12=1352(LC 20)

FORCES. (lb) - Max. Comp./Max. Ten. - All forces 250 (lb) or less except when shown.

TOP CHORD	2-4=-1476/0, 4-5=-916/151, 5-6=-22/326, 6-7=-22/326, 7-8=-916/151, 8-10=-1475/0, 2-16=-1461/38, 10-12=-1462/38
BOT CHORD	15-16=-296/437, 13-15=0/956
WEBS	8-13=0/667, 4-15=0/667, 2-15=0/844, 10-13=0/849, 5-7=-1269/232

- NOTES-**
- Unbalanced roof live loads have been considered for this design.
 - Wind: ASCE 7-10; Vult=130mph Vasd=103mph; TCCL=6.0psf; BCCL=6.0psf; h=15ft; Cat. II; Exp C; Enclosed; MWFRS (envelope) and C-C Exterior(2) -0-9-2 to 3-7-11, Interior(1) 3-7-11 to 10-2-8, Exterior(2) 10-2-8 to 14-7-5, Interior(1) 14-7-5 to 21-2-2 zone; end vertical left and right exposed; C-C for members and forces & MWFRS for reactions shown; Lumber DOL=1.60 plate grip DOL=1.60
 - This truss has been designed for a 10.0 psf bottom chord live load nonconcurrent with any other live loads.
 - * This truss has been designed for a live load of 30.0psf on the bottom chord in all areas where a rectangle 3-6-0 tall by 2-0-0 wide will fit between the bottom chord and any other members.
 - Ceiling dead load (10.0 psf) on member(s). 4-5, 7-8, 5-7; Wall dead load (5.0psf) on member(s).8-13, 4-15
 - Bottom chord live load (40.0 psf) and additional bottom chord dead load (10.0 psf) applied only to room. 13-15
 - Attic room checked for L/360 deflection.

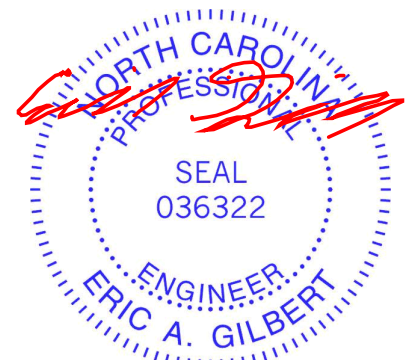

April 17, 2024

WARNING - Verify design parameters and READ NOTES ON THIS AND INCLUDED MITEK REFERENCE PAGE MII-7473 rev. 1/2/2023 BEFORE USE.

Design valid for use only with MiTek® connectors. This design is based only upon parameters shown, and is for an individual building component, not a truss system. Before use, the building designer must verify the applicability of design parameters and properly incorporate this design into the overall building design. Bracing indicated is to prevent buckling of individual truss web and/or chord members only. Additional temporary and permanent bracing is always required for stability and to prevent collapse with possible personal injury and property damage. For general guidance regarding the fabrication, storage, delivery, erection and bracing of trusses and truss systems, see **ANSI/TP1 Quality Criteria and DSB-22** available from Truss Plate Institute (www.tpinst.org) and **BCSI Building Component Safety Information** available from the Structural Building Component Association (www.sbcacomponents.com)

ENGINEERING BY
TRENCO
 A MiTek Affiliate

818 Soundside Road
 Edenton, NC 27932

Job J0424-2222	Truss C1GE	Truss Type ROOF TRUSS	Qty 1	Ply 1	Wellco/Lot 10 Overhills Creek/Harnett Job Reference (optional)	164935123
-------------------	---------------	--------------------------	----------	----------	---	-----------

Comtech, Inc. Fayetteville, NC - 28314,

8.430 s Jan 6 2022 MiTek Industries, Inc. Tue Apr 16 10:01:14 2024 Page 1

ID:Yb7beGiAPPG119hcw?SQQjyfOh?RfC?PsB70Hq3NSgPqnL8w3uITXbGKWrCDoi7J4zJC?f

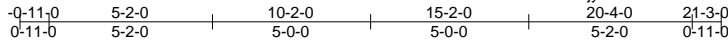

6x8 =

Scale = 1:72.8

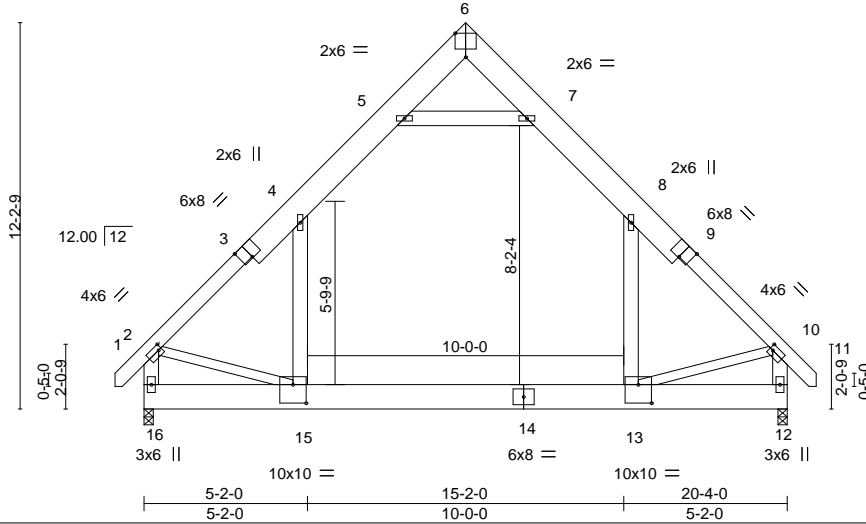

Plate Offsets (X, Y)--	[2:0-1-4,0-2-0], [3:0-4-0,Edge], [6:0-4-0,Edge], [9:0-4-0,Edge], [10:0-1-4,0-2-0], [13:0-5-0,0-7-0], [15:0-5-0,0-7-0]
------------------------	---

LOADING (psf)	SPACING-	2-0-0	CSI.	DEFL.	in (loc)	l/defl	L/d	PLATES	GRIP
TCLL 20.0	Plate Grip DOL	1.15	TC 0.36	Vert(LL)	-0.10 13-15	>999	360	MT20	244/190
TCDL 10.0	Lumber DOL	1.15	BC 0.50	Vert(CT)	-0.16 13-15	>999	240		
BCLL 0.0 *	Rep Stress Incr	YES	WB 0.18	Horz(CT)	0.01 12	n/a	n/a		
BCDL 10.0	Code IRC2015/TPI2014		Matrix-S	Wind(LL)	0.05 13-15	>999	240	Weight: 240 lb	FT = 20%

LUMBER-	BRACING-
TOP CHORD 2x6 SP No.1 *Except* 3-6,6-9: 2x10 SP No.1	TOP CHORD Structural wood sheathing directly applied or 5-11-14 oc purlins, except end verticals.
BOT CHORD 2x10 SP No.1	BOT CHORD Rigid ceiling directly applied or 10-0-0 oc bracing.
WEBS 2x6 SP No.1 *Except* 2-15,10-13: 2x4 SP No.2	

REACTIONS. (size) 16=0-3-8, 12=0-3-8
 Max Horz 16=391(LC 10)
 Max Grav 16=1347(LC 21), 12=1347(LC 20)

FORCES. (lb) - Max. Comp./Max. Ten. - All forces 250 (lb) or less except when shown.
 TOP CHORD 2-4=-1489/26, 4-5=-922/180, 5-6=-52/335, 6-7=-52/335, 7-8=-922/179, 8-10=-1489/26,
 2-16=-1469/62, 10-12=-1470/62
 BOT CHORD 15-16=-385/521, 13-15=0/984
 WEBS 8-13=0/667, 4-15=0/667, 2-15=-14/882, 10-13=-21/888, 5-7=-1260/312

- NOTES-**
- Unbalanced roof live loads have been considered for this design.
 - Wind: ASCE 7-10; Vult=130mph Vasd=103mph; TC DL=6.0psf; BC DL=6.0psf; h=15ft; Cat. II; Exp C; Enclosed; MWFRS (envelope) gable end zone and C-C Corner(3) 0-9-2 to 3-7-11, Exterior(2) 3-7-11 to 10-2-8, Corner(3) 10-2-8 to 14-7-5, Exterior(2) 14-7-5 to 21-2-2 zone; end vertical left and right exposed; C-C for members and forces & MWFRS for reactions shown; Lumber DOL=1.60 plate grip DOL=1.60
 - This truss has been designed for a 10.0 psf bottom chord live load nonconcurrent with any other live loads.
 - * This truss has been designed for a live load of 30.0psf on the bottom chord in all areas where a rectangle 3-6-0 tall by 2-0-0 wide will fit between the bottom chord and any other members.
 - Ceiling dead load (10.0 psf) on member(s). 4-5, 7-8, 5-7; Wall dead load (5.0psf) on member(s). 8-13, 4-15
 - Bottom chord live load (40.0 psf) and additional bottom chord dead load (10.0 psf) applied only to room. 13-15
 - Attic room checked for L/360 deflection.

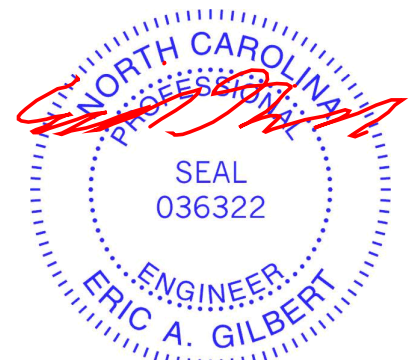

April 17, 2024

WARNING - Verify design parameters and READ NOTES ON THIS AND INCLUDED MITEK REFERENCE PAGE MII-7473 rev. 1/2/2023 BEFORE USE.

Design valid for use only with MiTek® connectors. This design is based only upon parameters shown, and is for an individual building component, not a truss system. Before use, the building designer must verify the applicability of design parameters and properly incorporate this design into the overall building design. Bracing indicated is to prevent buckling of individual truss web and/or chord members only. Additional temporary and permanent bracing is always required for stability and to prevent collapse with possible personal injury and property damage. For general guidance regarding the fabrication, storage, delivery, erection and bracing of trusses and truss systems, see **ANSI/TP1 Quality Criteria and DSB-22** available from Truss Plate Institute (www.tpinst.org) and **BCSI Building Component Safety Information** available from the Structural Building Component Association (www.sbcacomponents.com)

ENGINEERING BY
TRENCO
 A MiTek Affiliate

818 Soundside Road
 Edenton, NC 27932

Job J0424-2222	Truss C3	Truss Type ROOF TRUSS	Qty 1	Ply 2	Wellco/Lot 10 Overhills Creek/Harnett Job Reference (optional)	164935125
-------------------	-------------	--------------------------	----------	----------	---	-----------

Comtech, Inc. Fayetteville, NC - 28314,

8.430 s Jan 6 2022 MiTek Industries, Inc. Tue Apr 16 10:01:15 2024 Page 1

ID:Yb7beGiAPPG119hcw?SQQjyfOh?-RfC?PsB70Hq3NSgPqnL8w3uITXbGKWrCDoi?J4zJC?f

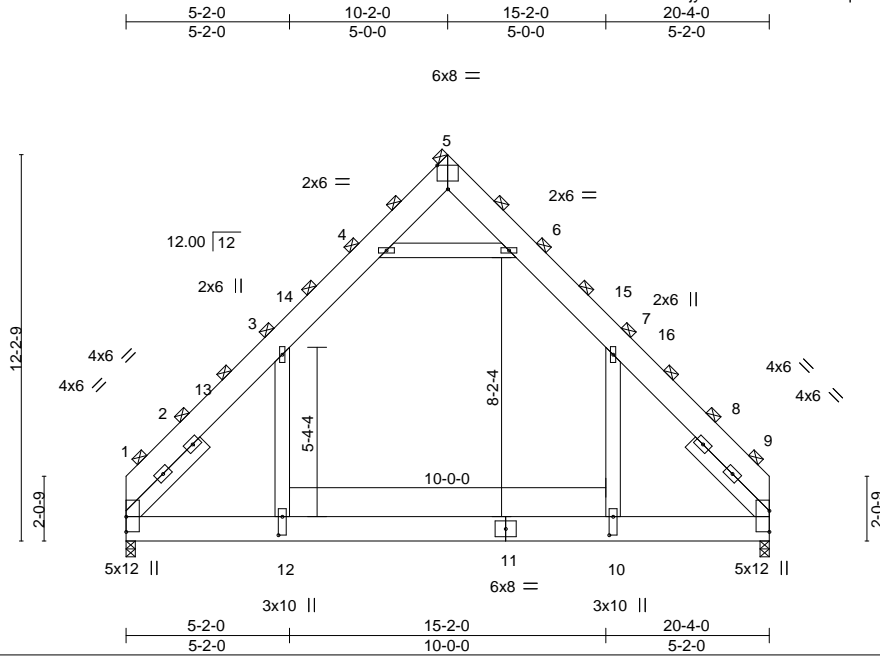

Scale = 1:72.8

Plate Offsets (X,Y)--	[5:0-4-0,Edge], [10:0-7-0,0-1-8], [12:0-7-0,0-1-8]
-----------------------	--

LOADING (psf)	SPACING-	4-0-0	CSI.	DEFL.	in (loc)	l/defl	L/d	PLATES	GRIP
TCLL 20.0	Plate Grip DOL	1.15	TC 0.45	Vert(LL)	-0.09	10-12	>999	MT20	244/190
TCDL 10.0	Lumber DOL	1.15	BC 0.53	Vert(CT)	-0.15	10-12	>999		
BCLL 0.0 *	Rep Stress Incr	NO	WB 0.13	Horz(CT)	0.01	9	n/a		
BCDL 10.0	Code IRC2015/TPI2014		Matrix-S	Wind(LL)	0.03	12	>999		
								Weight: 500 lb	FT = 20%

LUMBER-
TOP CHORD 2x10 SP No.1
BOT CHORD 2x10 SP No.1
WEBS 2x6 SP No.1
SLIDER Left 2x6 SP No.1 3-5-3, Right 2x6 SP No.1 3-5-3

BRACING-
TOP CHORD 2-0-0 oc purlins (6-0-0 max.)
(Switched from sheeted: Spacing > 2-8-0).
BOT CHORD Rigid ceiling directly applied or 10-0-0 oc bracing.

REACTIONS. (size) 1=0-3-8, 9=0-3-8
Max Horz 1=-541(LC 8)
Max Grav 1=2652(LC 21), 9=2652(LC 20)

FORCES. (lb) - Max. Comp./Max. Ten. - All forces 250 (lb) or less except when shown.
TOP CHORD 1-3=-3466/0, 3-4=-1879/304, 4-5=-38/575, 5-6=-41/576, 6-7=-1879/304, 7-9=-3463/0
BOT CHORD 1-12=0/1942, 10-12=0/1952, 9-10=0/1940
WEBS 7-10=0/1810, 3-12=0/1810, 4-6=-2484/465

- NOTES-**
- 2-ply truss to be connected together with 10d (0.131"x3") nails as follows:
Top chords connected as follows: 2x10 - 2 rows staggered at 0-9-0 oc.
Bottom chords connected as follows: 2x10 - 2 rows staggered at 0-9-0 oc.
Webs connected as follows: 2x6 - 2 rows staggered at 0-9-0 oc.
 - All loads are considered equally applied to all plies, except if noted as front (F) or back (B) face in the LOAD CASE(S) section. Ply to ply connections have been provided to distribute only loads noted as (F) or (B), unless otherwise indicated.
 - Unbalanced roof live loads have been considered for this design.
 - Wind: ASCE 7-10; Vult=130mph Vasd=103mph; TC DL=6.0psf; BCDL=6.0psf; h=15ft; Cat. II; Exp C; Enclosed; MWFRS (envelope) and C-C Exterior(2) 0-0-8 to 4-5-5, Interior(1) 4-5-5 to 10-2-8, Exterior(2) 10-2-8 to 14-7-5, Interior(1) 14-7-5 to 20-4-8 zone; C-C for members and forces & MWFRS for reactions shown; Lumber DOL=1.60 plate grip DOL=1.60
 - This truss has been designed for a 10.0 psf bottom chord live load nonconcurrent with any other live loads.
 - * This truss has been designed for a live load of 30.0psf on the bottom chord in all areas where a rectangle 3-6-0 tall by 2-0-0 wide will fit between the bottom chord and any other members.
 - Ceiling dead load (10.0 psf) on member(s). 3-4, 6-7, 4-6; Wall dead load (5.0psf) on member(s). 7-10, 3-12
 - Bottom chord live load (40.0 psf) and additional bottom chord dead load (10.0 psf) applied only to room. 10-12
 - Graphical purlin representation does not depict the size or the orientation of the purlin along the top and/or bottom chord.
 - Attic room checked for L/360 deflection.

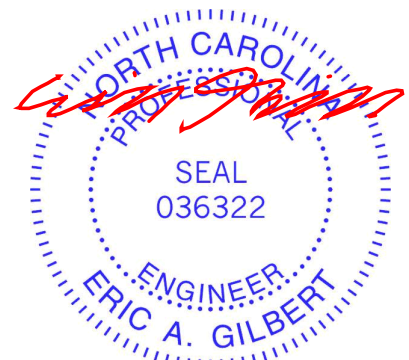

April 17, 2024

<p>WARNING - Verify design parameters and READ NOTES ON THIS AND INCLUDED MITEK REFERENCE PAGE MII-7473 rev. 1/2/2023 BEFORE USE.</p> <p>Design valid for use only with MiTek® connectors. This design is based only upon parameters shown, and is for an individual building component, not a truss system. Before use, the building designer must verify the applicability of design parameters and properly incorporate this design into the overall building design. Bracing indicated is to prevent buckling of individual truss web and/or chord members only. Additional temporary and permanent bracing is always required for stability and to prevent collapse with possible personal injury and property damage. For general guidance regarding the fabrication, storage, delivery, erection and bracing of trusses and truss systems, see ANSI/TPH Quality Criteria and DSB-22 available from Truss Plate Institute (www.tpinst.org) and BCSI Building Component Safety Information available from the Structural Building Component Association (www.sbcacomponents.com)</p>	<p>ENGINEERING BY</p> <p>TRENCO</p> <p>A MiTek Affiliate</p> <p>818 Soundside Road Edenton, NC 27932</p>
--	---

Job J0424-2222	Truss M1GE	Truss Type GABLE	Qty 1	Ply 1	Wellco/Lot 10 Overhills Creek/Harnett Job Reference (optional)	164935126
-------------------	---------------	---------------------	----------	----------	---	-----------

Comtech, Inc. Fayetteville, NC - 28314,

8.430 s Jan 6 2022 MiTek Industries, Inc. Tue Apr 16 10:01:16 2024 Page 1

ID:Yb7beGiAPPG119hcv?SQQjyfOh?-RfC?PsB70Hq3NSgPqnL8w3uITXbGKWrCDoi7J4zJC?f

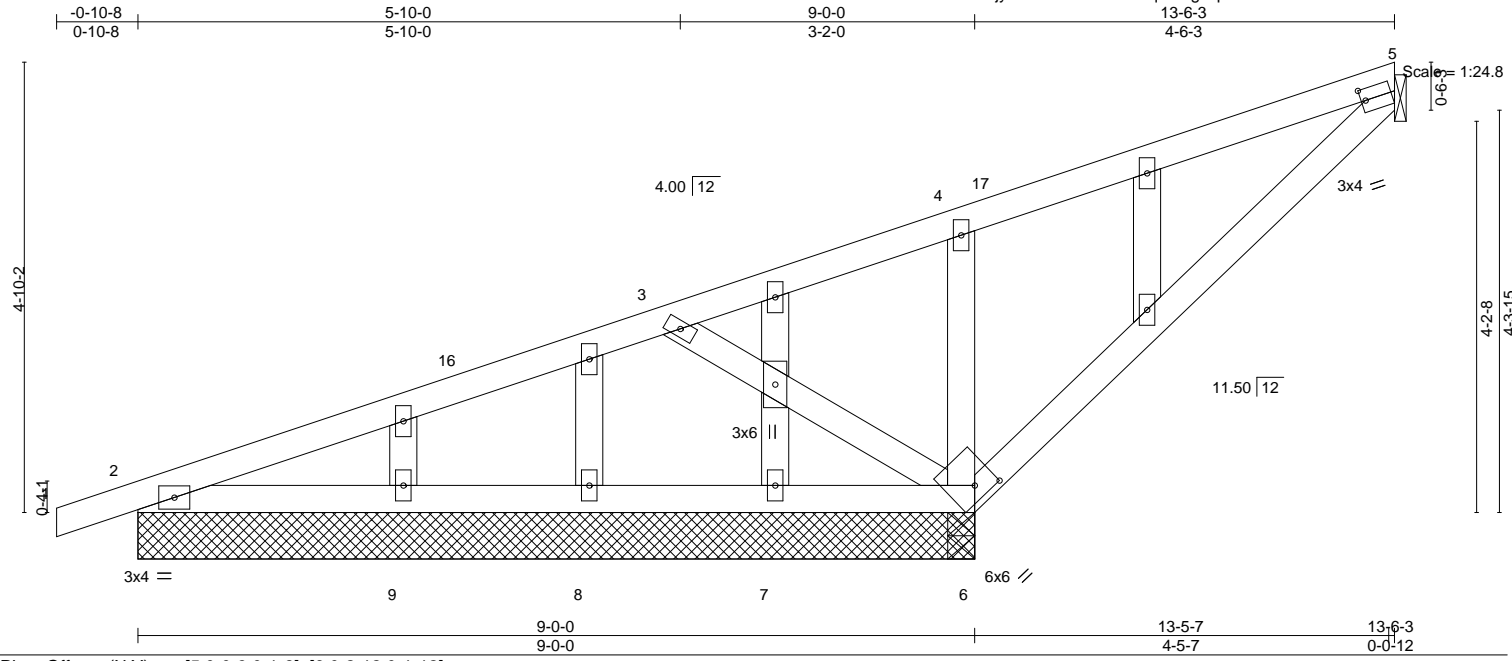

Plate Offsets (X, Y)--	[5:0-0-9,0-1-8], [6:0-2-12,0-1-12]
------------------------	------------------------------------

LOADING (psf)	SPACING-	2-0-0	CSI.	DEFL.	in (loc)	l/defl	L/d	PLATES	GRIP
TCLL 20.0	Plate Grip DOL	1.15	TC 0.24	Vert(LL)	-0.02	5-6	>999	MT20	244/190
TCDL 10.0	Lumber DOL	1.15	BC 0.19	Vert(CT)	-0.05	5-6	>999		
BCLL 0.0 *	Rep Stress Incr	YES	WB 0.08	Horz(CT)	-0.00	6	n/a		
BCDL 10.0	Code IRC2015/TPI2014		Matrix-S	Wind(LL)	0.01	5-6	>999	Weight: 63 lb	FT = 20%

LUMBER-	BRACING-
TOP CHORD 2x4 SP No.1	TOP CHORD Structural wood sheathing directly applied or 6-0-0 oc purlins.
BOT CHORD 2x4 SP No.1	BOT CHORD Rigid ceiling directly applied or 10-0-0 oc bracing. Except:
WEBS 2x4 SP No.2	6-0-0 oc bracing: 5-6.
OTHERS 2x4 SP No.2	

REACTIONS. All bearings 9-0-0 except (jt=length) 5=Mechanical.
 (lb) - Max Horz 2=231(LC 8)
 Max Uplift All uplift 100 lb or less at joint(s) 5, 9 except 2=101(LC 8), 6=280(LC 12)
 Max Grav All reactions 250 lb or less at joint(s) 5, 9, 8, 7 except 2=266(LC 1), 6=639(LC 1), 6=639(LC 1)

FORCES. (lb) - Max. Comp./Max. Ten. - All forces 250 (lb) or less except when shown.
 WEBS 3-6=-345/234, 4-6=-251/174

- NOTES-**
- 1) Wind: ASCE 7-10; Vult=130mph Vasd=103mph; TCDL=6.0psf; BCDL=6.0psf; h=15ft; Cat. II; Exp C; Enclosed; MWFRS (envelope) gable end zone and C-C Exterior(2) -0-10-8 to 3-6-5, Interior(1) 3-6-5 to 13-7-15 zone; C-C for members and forces & MWFRS for reactions shown; Lumber DOL=1.60 plate grip DOL=1.60
 - 2) Truss designed for wind loads in the plane of the truss only. For studs exposed to wind (normal to the face), see Standard Industry Gable End Details as applicable, or consult qualified building designer as per ANSI/TPI 1.
 - 3) All plates are 2x4 MT20 unless otherwise indicated.
 - 4) Gable studs spaced at 2-0-0 oc.
 - 5) This truss has been designed for a 10.0 psf bottom chord live load nonconcurrent with any other live loads.
 - 6) * This truss has been designed for a live load of 30.0psf on the bottom chord in all areas where a rectangle 3-6-0 tall by 2-0-0 wide will fit between the bottom chord and any other members.
 - 7) Refer to girder(s) for truss to truss connections.
 - 8) Provide mechanical connection (by others) of truss to bearing plate capable of withstanding 100 lb uplift at joint(s) 5, 9 except (jt=lb) 2=101, 6=280.

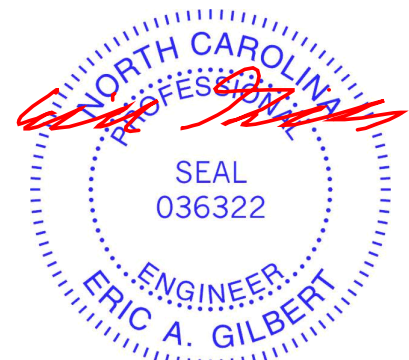

April 17, 2024

<p>WARNING - Verify design parameters and READ NOTES ON THIS AND INCLUDED MITEK REFERENCE PAGE MII-7473 rev. 1/2/2023 BEFORE USE.</p> <p>Design valid for use only with MiTek® connectors. This design is based only upon parameters shown, and is for an individual building component, not a truss system. Before use, the building designer must verify the applicability of design parameters and properly incorporate this design into the overall building design. Bracing indicated is to prevent buckling of individual truss web and/or chord members only. Additional temporary and permanent bracing is always required for stability and to prevent collapse with possible personal injury and property damage. For general guidance regarding the fabrication, storage, delivery, erection and bracing of trusses and truss systems, see ANSI/TPI1 Quality Criteria and DSB-22 available from Truss Plate Institute (www.tpinst.org) and BCSI Building Component Safety Information available from the Structural Building Component Association (www.sbcacomponents.com)</p>	<p>ENGINEERING BY</p> <p>TRENCO</p> <p>A MiTek Affiliate</p> <p>818 Soundside Road Edenton, NC 27932</p>
---	---

Job J0424-2222	Truss M2	Truss Type Roof Special	Qty 1	Ply 1	Wellco/Lot 10 Overhills Creek/Harnett Job Reference (optional)	I64935127
-------------------	-------------	----------------------------	----------	----------	---	-----------

Comtech, Inc. Fayetteville, NC - 28314,

8.430 s Jan 6 2022 MiTek Industries, Inc. Tue Apr 16 10:01:16 2024 Page 1

ID:Yb7beGiAPPG119hcw?SQQjyfOh?-RfC?PsB70Hq3NSgPqnL8w3uITXbGKWRCDoi7J4zJC?f

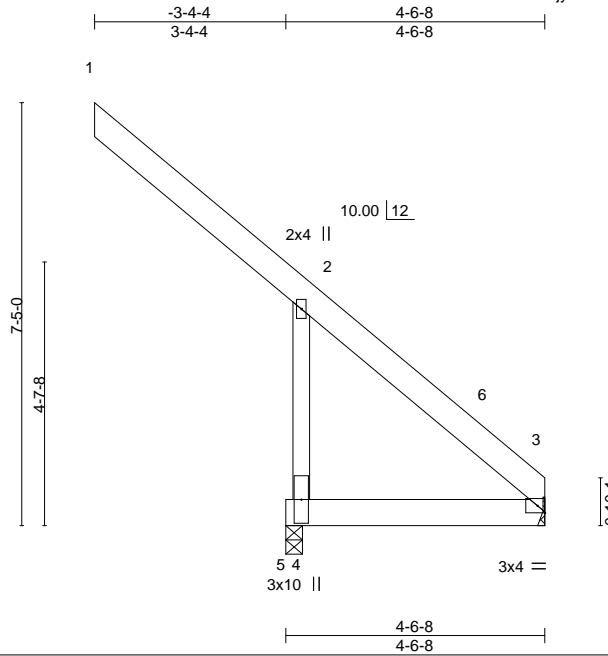

Scale = 1:40.4

LOADING (psf)	SPACING-	2-0-0	CSI.	DEFL.	in (loc)	l/defl	L/d	PLATES	GRIP
TCLL 20.0	Plate Grip DOL	1.15	TC 0.44	Vert(LL)	-0.00	3-4	>999	MT20	244/190
TCDL 10.0	Lumber DOL	1.15	BC 0.07	Vert(CT)	-0.01	3-4	>999		
BCLL 0.0 *	Rep Stress Incr	YES	WB 0.00	Horz(CT)	0.00	3	n/a		
BCDL 10.0	Code IRC2015/TPI2014		Matrix-P	Wind(LL)	0.00	4	****	Weight: 41 lb	FT = 20%

LUMBER-
 TOP CHORD 2x6 SP No.1
 BOT CHORD 2x6 SP No.1
 WEBS 2x4 SP No.2

BRACING-
 TOP CHORD Structural wood sheathing directly applied or 4-6-8 oc purlins, except end verticals.
 BOT CHORD Rigid ceiling directly applied or 10-0-0 oc bracing.

REACTIONS. (size) 4=0-3-8, 3=Mechanical
 Max Horz 4=-204(LC 8)
 Max Uplift 4=-320(LC 8), 3=-11(LC 9)
 Max Grav 4=508(LC 20), 3=233(LC 8)

FORCES. (lb) - Max. Comp./Max. Ten. - All forces 250 (lb) or less except when shown.
 TOP CHORD 2-4=-608/791, 2-3=-578/355
 BOT CHORD 3-4=-258/426

NOTES-

- 1) Wind: ASCE 7-10; Vult=130mph Vasd=103mph; TCDL=6.0psf; BCDL=6.0psf; h=15ft; Cat. II; Exp C; Enclosed; MWFRS (envelope) and C-C Exterior(2) -3-4-4 to 2-10-7, Interior(1) 2-10-7 to 4-5-12 zone; C-C for members and forces & MWFRS for reactions shown; Lumber DOL=1.60 plate grip DOL=1.60
- 2) This truss has been designed for a 10.0 psf bottom chord live load nonconcurrent with any other live loads.
- 3) * This truss has been designed for a live load of 30.0psf on the bottom chord in all areas where a rectangle 3-6-0 tall by 2-0-0 wide will fit between the bottom chord and any other members.
- 4) Refer to girder(s) for truss to truss connections.
- 5) Provide mechanical connection (by others) of truss to bearing plate capable of withstanding 100 lb uplift at joint(s) 3 except (jt=lb) 4=320.

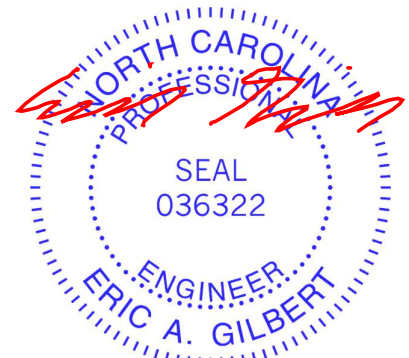

April 17, 2024

WARNING - Verify design parameters and READ NOTES ON THIS AND INCLUDED MITEK REFERENCE PAGE MII-7473 rev. 1/2/2023 BEFORE USE.

Design valid for use only with MiTek® connectors. This design is based only upon parameters shown, and is for an individual building component, not a truss system. Before use, the building designer must verify the applicability of design parameters and properly incorporate this design into the overall building design. Bracing indicated is to prevent buckling of individual truss web and/or chord members only. Additional temporary and permanent bracing is always required for stability and to prevent collapse with possible personal injury and property damage. For general guidance regarding the fabrication, storage, delivery, erection and bracing of trusses and truss systems, see **ANSI/TPH Quality Criteria and DSB-22** available from Truss Plate Institute (www.tpinst.org) and **BCSI Building Component Safety Information** available from the Structural Building Component Association (www.sbcacomponents.com)



818 Soundside Road
 Edenton, NC 27932

Symbols

PLATE LOCATION AND ORIENTATION

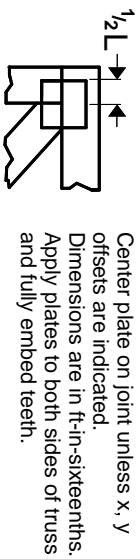

Center plate on joint unless x, y offsets are indicated. Dimensions are in ft-in-sixteenths. Apply plates to both sides of truss and fully embed teeth.

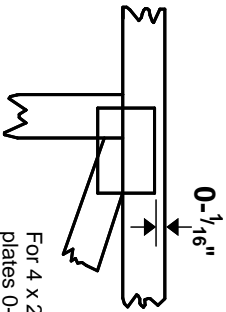

For 4 x 2 orientation, locate plates 0- $\frac{1}{16}$ \" from outside edge of truss.



This symbol indicates the required direction of slots in connector plates.

* Plate location details available in MITek software or upon request.

PLATE SIZE

4 X 4

The first dimension is the plate width measured perpendicular to slots. Second dimension is the length parallel to slots.

LATERAL BRACING LOCATION



Indicated by symbol shown and/or by text in the bracing section of the output. Use T or I bracing if indicated.

BEARING



Indicates location where bearings (supports) occur. Icons vary but reaction section indicates joint number/letter where bearings occur. Min size shown is for crushing only.

Industry Standards:

ANSI/TP1: National Design Specification for Metal Plate Connected Wood Truss Construction.
DSB-22: Design Standard for Bracing.
BCSI: Building Component Safety Information, Guide to Good Practice for Handling, Installing, Restraining & Bracing of Metal Plate Connected Wood Trusses.

Numbering System



1 TOP CHORDS
2 Joint ID typ.

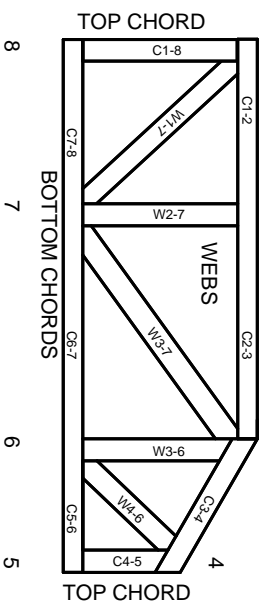

JOINTS ARE GENERALLY NUMBERED/LETTERED CLOCKWISE AROUND THE TRUSS STARTING AT THE JOINT FARTHEST TO THE LEFT.

CHORDS AND WEBS ARE IDENTIFIED BY END JOINT NUMBERS/LETTERS.

Product Code Approvals

ICC-ES Reports:

ESR-1988, ESR-2362, ESR-2685, ESR-3282
ESR-4722, ESL-1388

Design General Notes

Trusses are designed for wind loads in the plane of the truss unless otherwise shown.

Lumber design values are in accordance with ANSI/TP1 section 6.3. These truss designs rely on lumber values established by others.

© 2023 MITek® All Rights Reserved

General Safety Notes

Failure to Follow Could Cause Property Damage or Personal Injury

1. Additional stability/bracing for truss system, e.g. diagonal or X-bracing, is always required. See BCSI.
2. Truss bracing must be designed by an engineer. For wide truss spacing, individual lateral braces themselves may require bracing, or alternative Tor I bracing should be considered.
3. Never exceed the design loading shown and never stack materials on inadequately braced trusses.
4. Provide copies of this truss design to the building designer, erection supervisor, property owner and all other interested parties.
5. Cut members to bear tightly against each other.
6. Place plates on each face of truss at each joint and embed fully. Knots and wane at joint locations are regulated by ANSI/TP1 1.
7. Design assumes trusses will be suitably protected from the environment in accord with ANSI/TP1 1.
8. Unless otherwise noted, moisture content of lumber shall not exceed 19% at time of fabrication.
9. Unless expressly noted, this design is not applicable for use with fire retardant, preservative treated, or green lumber.
10. Camber is a non-structural consideration and is the responsibility of truss fabricator. General practice is to camber for dead load deflection.
11. Plate type, size, orientation and location dimensions indicated are minimum plating requirements.
12. Lumber used shall be of the species and size, and in all respects, equal to or better than that specified.
13. Top chords must be sheathed or purlins provided at spacing indicated on design.
14. Bottom chords require lateral bracing at 10 ft. spacing, or less, if no ceiling is installed, unless otherwise noted.
15. Connections not shown are the responsibility of others.
16. Do not cut or alter truss member or plate without prior approval of an engineer.
17. Install and load vertically unless indicated otherwise.
18. Use of green or treated lumber may pose unacceptable environmental, health or performance risks. Consult with project engineer before use.
19. Review all portions of this design (front, back, words and pictures) before use. Reviewing pictures alone is not sufficient.
20. Design assumes manufacture in accordance with ANSI/TP1 Quality Criteria.
21. The design does not take into account any dynamic or other loads other than those expressly stated.

MITek

ENGINEERING BY
TRENGO
A MITek Affiliate

MITek Engineering Reference Sheet: MIL-7473 rev. 1/2/2023