

IT IS THE SOLE RESPONSIBILITY OF THE CONTRACTOR AND/OR BUILDER TO CONFORM TO ALL STANDARDS, PROVISIONS, REQUIREMENTS, METHODS OF CONSTRUCTION AND USES OF MATERIALS, IN BUILDING CODES ANY OTHER LOCAL AGENCIES AND IN ACCORDANCE WITH GOOD ENGINEERING AND CONSTRUCTION PRACTICES.

I CERTIFY THAT THE CONSTRUCTION EXHIBITS FOR (IDENTIFICATION OF THE PROPERTY BY HOUSE TYPE, LOT, BLOCK, SUBDIVISION NAME, AND SO ON) MEET ALL LOCAL CODE REQUIREMENTS AND ARE IN SUBSTANTIAL CONFORMITY WITH BOTH SAH AND VA MINIMUM PROPERTY REQUIREMENTS, ALL BUILDING STANDARDS AS SET FORTH BY THE INTERNATIONAL CODE COUNCIL (ICC) AND FEDERAL SAFE DRINKING WATER PLUMBING STANDARD.

DESIGNED BY:
TIMOTHY PEPPERS JR.
RESIDENTIAL DESIGN
CONSULTANT

CAMERON
NORTH CAROLINA
(910) 644-4587

PROPERTY OF TPJR
DRAWINGS AND SPECIFICATIONS AS INSTRUMENTS OF SERVICE ARE AND SHALL REMAIN PROPERTY OF THE DESIGNER WHETHER THE PROJECT FOR WHICH THEY ARE MADE FOR IS EXECUTED OR NOT. THE DRAWINGS AND SPECIFICATIONS SHALL NOT BE USED BY THE OWNER ON OTHER PROJECTS OR FOR ADDITIONS TO THIS PROJECT OR FOR COMPLETION OF THIS PROJECT BY OTHERS EXCEPT BY AGREEMENT IN WRITING WITH THE APPROPRIATE COMPENSATION TO THE DESIGNER.

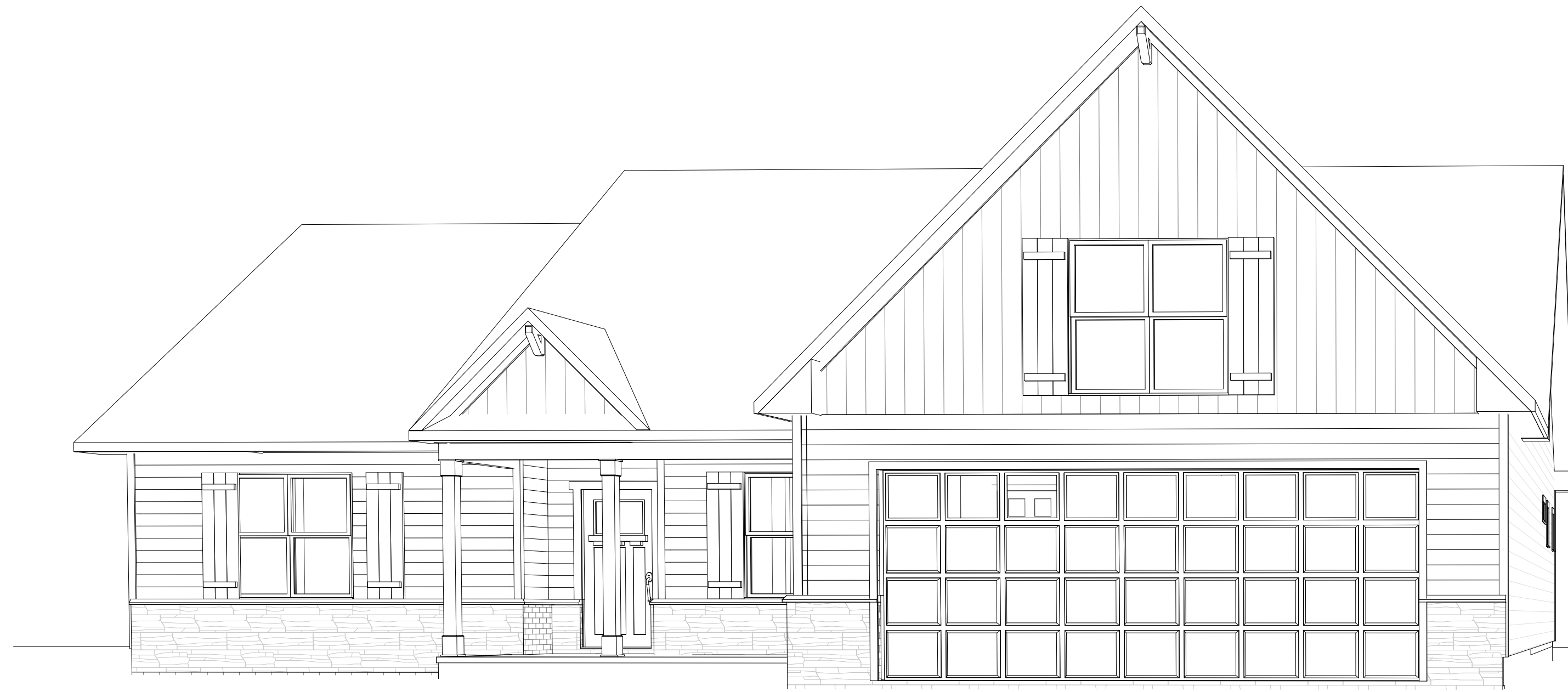

② Exterior East

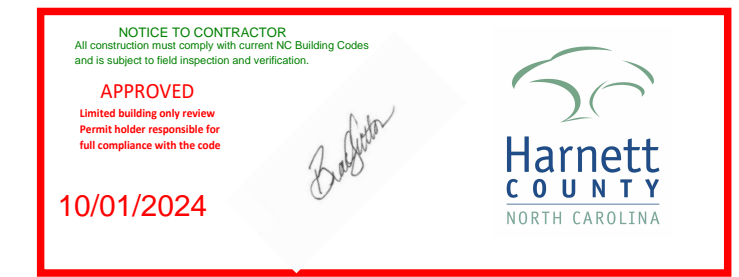

Use	Live Load (PSF)	Dead Load (PSF)	Deflection (LL)
Attic Without Storage	10	10	L/240
Attic With Limited Storage	20	10	L/360
Attic With Fixed Stairs	40	10	L/360
Balconies & Decks	40	10	L/360
Fire Escapes	40	10	L/360
Guardrails & Handrails	200	--	--
Guardrail Infill Components	50	--	--
Passenger Vehicle Garages	50	10	L/360
Rooms Other Than Sleeping	40	10	L/360
Sleeping Rooms	30	10	L/360
Stairs	40	--	L/360
Snow	20	--	--

GENERAL CONSTRUCTION NOTES:

1. Design Loads: Local
2. Materials
 - A. Brick
 - Face Brick Standard: ASTM C216-84, Grade SW.
 - Brick type and color to match existing.
 - B. Mortar
 - ASTM C270, Type S. Mortar style and color consult owner
 - Do not use calcium chloride in mortar.
 - C. Brick Ties
 - ASTM A82 steel wire, hot dip galvanized after fabrication to ASTM A 153/A 153M, Class B
 - D. Insulation
 - ASTM C665; pre-formed glass fiber batt (R-19)
 - E. Wood Framing
 - No. 2 Southern Pine
 - F. Waterproofing
 - #15 asphalt felt
 - G. Roof Shingles
 - Match existing
3. Masonry:
 - A. Install mortar in accordance with premix mortar instructions or in accordance with ASTM C780.
 - B. Clean mortar off exposed finished surfaces immediately following placement.
 - C. Conform to the applicable code requirements for masonry construction and guidelines outlined by the Brick Institute of America.
 - D. Provide brick ties.
 - E. Cut masonry units with motor-driven saws to provide clean, sharp, unchipped edges.
 - F. Prepare masonry surfaces so they are smooth and free from projections that could puncture flashing. Place through-wall flashing on sloping bed of mortar and cover with mortar. Seal penetrations in flashing with adhesive/sealant/tape as recommended by flashing manufacturer before covering with mortar.
 - G. Install weep holes in the head joints in exterior wythes of the first course of masonry immediately above embedded flashings as follows:
 - Keep head joints free and clear of mortar.
 - Space weep holes 24 inches o/c.
 - H. Weep Holes:
 - I. After wall construction is complete, clean brick with a non-acidic solution recommended by masonry unit manufacturer.

4. Insulation
 - A. Verify that adjacent materials and insulation materials are dry.
 - B. Install insulation per manufacturer's instructions.
 - C. Tape seal tears or cuts in vapor retarder.
5. Wood Framing
 - A. All field nailing will comply with the North Carolina State Building Code Fastening Schedule Table 2304.10.1 unless noted otherwise. All nails are to be common nails.
 - B. Miscellaneous framing not shown on the structural drawings may be required in some areas. Contractor will provide all framing required to complete the project.
 - C. Exterior Wall Sheathing:
 - a) Sheathing will be 1/2" plywood APA rated sheathing with an exterior exposure 1 durability rating.
 - b) Place long dimension of sheathing perpendicular to studs in a staggered arrangement. Fasten to studs with 10d common nails 6" o/c at all panel edges and 12" o/c at intermediate supports. Block all unsupported edges.
 - c) Leave 1/4" space at all panel edge joints and 1/8" space at all panel end joints unless otherwise recommended by manufacturer.
 - D. Plywood Roof Sheathing
 - a) Roof sheathing is to be APA rated with an exterior exposure 1 rating and a panel span rating of 32/16. Thickness of sheathing is to match existing roof sheathing thickness.
 - b) Place long dimension of sheathing perpendicular to outriggers. Remove sections of existing sheathing and stagger every other new plywood sheet back to the 2nd interior roof truss. Fasten to trusses and outriggers with 10d common nails, 6" o/c at all panel edges and 12" o/c at intermediate supports. Block all unsupported edges.
 - c) Leave 1/4" space at all panel edge joints and 1/8" space at all panel end joints unless otherwise recommended by the manufacturer.
 - E. Do not cut or notch new or existing framing unless required on this drawing.
6. Miscellaneous
 - A. The contractor will be responsible for properly guying and bracing the structure to resist live, dead, wind and construction loads during construction.
 - B. Verify all existing building dimensions, elevations and details with the field conditions.

The Bellhaven
 Weaver Development Co., Inc.
 Cover Sheet

SCALE:

DATE:
March 22, 2024

Project number
070423000001

Drawn by TP
Checked by TP

C

General Notes:

- All dimensions are given from the exterior face of the stud to the centerline of interior studs unless otherwise noted.
- All work shall be performed in conformance with the 2018 NC Building Code for One and Two Family Dwellings and all referenced standards.
- All finishes, appliances, equipment and fixtures shall be coordinated by Owner and G.C.
- G.C. to field verify all existing dimensions and conditions prior to commencing work.
- Drawings are an instrument to communicate intent of construction. Do not scale drawings.
- All doors and windows to be selected by Owner and provided and installed by G.C.
- All casework to be selected by Owner and provided and installed by G.C.

Building Width In Feet & Number of Jack Studs (Only Roof & Ceiling Supported Above)						
	20'	NJ	28'	NJ	36'	NJ
(1) 2x8	4'-6"	1	3'-10"	1	3'-5"	1
(1) 2x10	5'-8"	1	4'-11"	1	4'-4"	1
(1) 2x12	6'-11"	1	5'-11"	1	5'-3"	1
(2) 2x4	3'-6"	1	3'-2"	1	2'-10"	1
(2) 2x6	5'-5"	1	4'-8"	1	4'-2"	1
(2) 2x8	6'-10"	1	5'-11"	2	5'-4"	2
(2) 2x10	8'-5"	2	7'-3"	2	6'-6"	2
(2) 2x12	9'-9"	2	8'-5"	2	7'-6"	2

IT IS THE SOLE RESPONSIBILITY OF THE CONTRACTOR AND/OR BUILDER TO CONFORM TO ALL STANDARDS, PROVISIONS, REQUIREMENTS, METHODS OF CONSTRUCTION AND USES OF MATERIALS, IN BUILDING CODES ANY OTHER LOCAL AGENCIES AND IN ACCORDANCE WITH GOOD ENGINEERING AND CONSTRUCTION PRACTICES.

I CERTIFY THAT THE CONSTRUCTION EXHIBITS FOR (IDENTIFICATION OF THE PROPERTY BY HOUSE TYPE, LOT, BLOCK, SUBDIVISION NAME, AND SO ON) MEET ALL LOCAL CODE REQUIREMENTS AND ARE IN SUBSTANTIAL CONFORMITY WITH BOTH SAH AND VA MINIMUM PROPERTY REQUIREMENTS. ALL BUILDING STANDARDS AS SET FORTH BY THE INTERNATIONAL CODE COUNCIL (ICC) AND FEDERAL SAFE DRINKING WATER PLUMBING STANDARD.

DESIGNED BY:
TIMOTHY PEPPERS JR.
RESIDENTIAL DESIGN
CONSULTANT

**CAMERON
NORTH CAROLINA
(910) 644-4587**

PROPERTY OF TPJR

DRAWINGS AND SPECIFICATIONS AS INSTRUMENTS OF SERVICE ARE AND SHALL REMAIN PROPERTY OF THE DESIGNER WHETHER THE PROJECT FOR WHICH THEY ARE MADE FOR IS EXECUTED OR NOT. THE DRAWINGS AND SPECIFICATIONS SHALL NOT BE USED BY THE OWNER ON OTHER PROJECTS OR FOR ADDITIONS TO THIS PROJECT OR FOR COMPLETION OF THIS PROJECT BY OTHERS EXCEPT BY AGREEMENT IN WRITING WITH THE APPROPRIATE COMPENSATION TO THE DESIGNER.

**The Bellhaven
Weaver Development Co., Inc.
Floor Plan**

SCALE: 1/4" = 1'-0"

DATE: March 22, 2024

Project number: 070423000001

Drawn by: TP
Checked by: TP

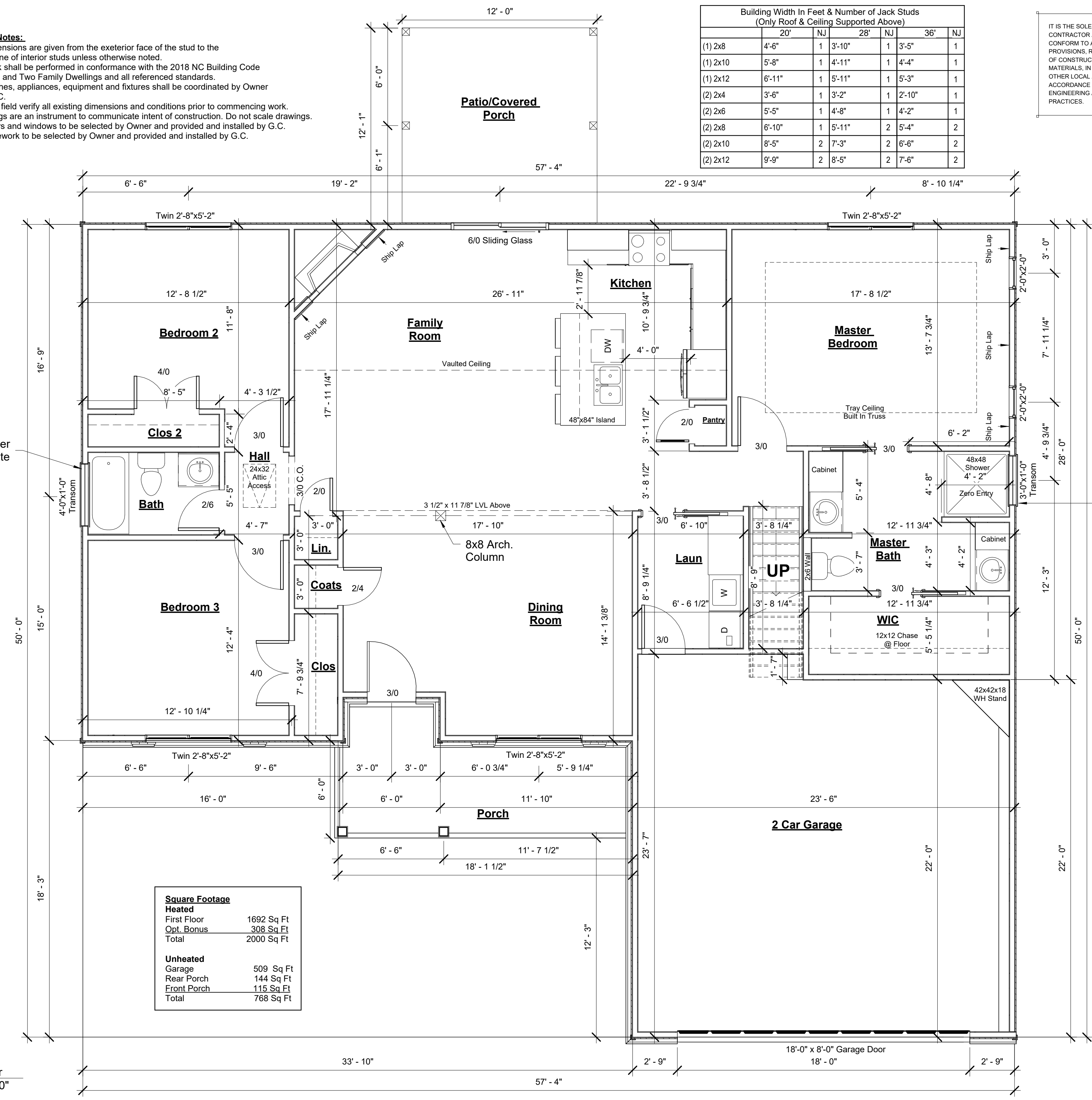

Square Footage	
Heated	
First Floor	1692 Sq Ft
Opt. Bonus	308 Sq Ft
Total	2000 Sq Ft
Unheated	
Garage	509 Sq Ft
Rear Porch	144 Sq Ft
Front Porch	115 Sq Ft
Total	768 Sq Ft

Floor Plan Notes:

- All structural information shown is for reference purposes only. Contractor shall have licensed structural engineer review and design all structural elements such as all framing walls, beams, connections, headers, joists and rafters.
- All dimensions are from center line of stud to face of exterior stud unless noted otherwise.
- Window sizes indicated on plans are noted by approximate rough opening size. Refer to plans and exterior elevations for window types.
- Coordinate location of utility meters with site plan and locate away from public view visual impact shall be minimized, i.e. mount as low as possible.
- Prefabricated fireplace construction shall meet or exceed all applicable codes regarding use of fire separations, clearances, etc. It is all items and contractor's responsibility to ensure that all items and construction meet or exceed the applicable code. Overall flue height shall be coordinated to match height shown on plans and shall not exceed the top of chimney chase as constructed.
- Constructor shall coordinate all closet shelving requirements.
- Do not scale drawings. Follow dimensions only.
- Contractor shall field verify all cabinet dimensions before fabrication.
- Bedroom windows shall have a minimum net clear opening of 5.7 sq. ft. A minimum net clear openable width of 20". A minimum net clear openable height of 24" and have a maximum finish sill height of 43" from finish floor.
- All glass located within 18" of floor, 12" of a door of located within 60" of floor at bathtubs, whirlpools, showers, saunas, steam rooms or hot tubs shall be tempered.
- All exposed insulation shall have a flame spread rating of less than 25 and a smoke density rating of less than 450.
- Provide combustion air vents, with screen and back damper, for fireplaces, wood stoves and any appliance with an open flame.
- Bathrooms and utility rooms shall be vented to the outside with a minimum of a 90 cfm fan. Range hoods shall also be vented to outside.
- Attic HVAC units shall be located within 20'-0" of its service opening. Return air grilles shall not be located within 10'-0" of a gas fired appliance.
- All walls and ceilings in garage and garage storage areas to have 5/8" Type-X gyp. brd. with 1-Hour fire rating. All exterior doors in garage to be metal or solid core doors including doors entering heat/cooled portion of residence.
- All fireplace chase walls shall be insulated inside and outside. Provide horizontal "Draft Stops" at each floor level by packing 6" (R-19) insulation between 2X4 joists.
- All interior walls shall be covered with 1/2" gyp. brd., with metal corner reinforcing, tape float and sand. (3 coats) use 5/8" gyp. brd. on ceilings when supporting members are 24" O.C. or greater. Use 1/2" gyp. brd. on ceiling members less than 24" O.C.
- All bath and toilet area walls and ceiling shall have water resistant gyp. brd.

Dwelling/Garage Separation

REFER TO SECTIONS R302.5, R302.6, AND R302.7

Walls. A minimum 1/2" gypsum board must be installed on all walls supporting floor/ceiling assemblies used for separation required by this section.

Stairs. A minimum of 1/2" gypsum must be installed on the underside and exposed sides of all stairways.

Ceilings. A minimum of 1/2" gypsum must be installed on the garage ceiling if there is no habitable room above. If a habitable room is above, a minimum of 5/8" Type X gypsum board must be installed on the the garage ceiling.

Opening Penetrations. Openings between the garage and the residence shall be equipped with solid wood doors not less than 1 3/8 inches in thickness, solid or honeycomb core steel doors not less than 1 3/8 inches thick, or 20-minute fire-rated doors.

Duct Penetrations. Ducts in the garage and ducts penetrating the walls or ceilings spartion the dwelling from the garage shall be constructed of a minimum No. 26 gage sheet steel or other approved material and shall have no openings into the garage.

Other Penetrations. Penetrations through the separation required in Section R302.6 shall be protected as required by Section R302.11, Item 4.

Walls & Thicknesses

All walls are 3 1/2" thick 2x4 nominal studs SYP or SPF #2 @ 16" O.C. unless otherwise noted.

Exterior walls are drawn to actual dimensions to include both interior and exterior finishes. Measurements to exterior walls are to the exterior face of wall stud.

Garage walls are drawn to actual dimensions. Measurements to exterior walls are to the exterior face of wall stud. Measurements to walls between the residence and the garage a to the face of the stud on the garage side.

Interior walls are drawn to actual dimension. Measurements to interior walls are to the center line of the wall.

Carbon Monoxide Alarms

Section R315

R315.1 Carbon Monoxide Alarms. Inn new construction, dwelling units shall be provided with an approved carbon monoxide alarm installed outside of each separate sleeping area in the immediate vicinity of the bedroom(s) as directed by the alarm manufacturer.

R315.2 Where Required In Existing Dwellings. In existing dwellings, where interior alterations, repairs, fuel-fired appliance replacements, or additions requiring a permit occurs, or where one or more sleeping rooms are added ot created, carbon monoxide alarms shall be provided in accordance with Section R315.1.

R315.3 Alarm Requirements. The required carbon monoxide alarms shall be audible in all bedrooms over background noise levels with all intervening doors closed. Single station carbon monoxide alarms shall be listed as complying with UL2034 and shall be installed in accordance with this code and the manufacturer's installation instructions.

Smoke Alarms

Section R314

R314.1 Smoke Detection and Notification. All smoke alarms shall be listed in accordance with UL 217 and installed in accordance with provisions of this code and the household fire warning equipment provisions fo NFPA 72.

R314.2 Smoke Detection Systems. Household fire alarm systems installed in accordance with NFPA 72 that include smoke alarms, or a combination of smoke detector and audible ntification device installed as required by this section for smoke alarms, shall be permitted. The household fire alarm system shall provide the same level of smoke detection and alarm as required by this section for smoke alarms. Where a household fire warning system is installed using a combination of smoke detector and audible notification device(s), it shall become a permanent fixture of the occupancy and owned by the homeowner. The system shall be monitored by and approved supervising station and be maintained in accordance with NFPA72.

Exception:

Where smoke alarms are provided meeting the requirements of Section R314.4.

R314.3 Location. Smoke alarms shall be installed in the following locations.

- In each sleeping room.
- Outside each separate sleeping area in the immediate vicinity of the bedrooms.
- On each additional story of the dwelling, including basements and habitable attics (finished) but not including crawl spaces, uninhabitable (unfinished) attics and unianhabitable (unfinished) attic-stories. In dwellings or dwelling units with split levels and without an intervening door between the adjacent levels, a smoke alarm installed on the upper level shall suffice for the adjacent lower level provided that the lower level is less than one full story below the upper level.

When more than one smoke alarm is required to be installed within an individual dwelling unit the alarm devices shl be interconnected in such a manner that the actuation of one alarm will activate all of the alarms in the individual unit.

R314.4 Power Source. Smoke alarms shall receive their primary power from the building wiring when such wiring is served from a commercial source, and when primary power is interrupted, shall receive power from a battery. Wiring shall be permanent and without a disconnection switch other than those required for overcurrent protection. Smoke alarms shall be interconnected.

Attic Access

Section R807

R807.1 Attic Access. An attic access opeing shall be provided to attic areas that exceed 400 square feet and have a vertical height of 60 inches or greater. The net clear opening shall not be less than 20 inches by 30 inches and shall be located in the hallway or other unobstructed area. Headroom in the attic space shall be provided at some point above the access opening. See Sectio M1305.1.3 for access requirements where mechanical equipments located above attics.

Exceptions:

- Concealed areas not located over the main structure including porches, areas behind knee walls, dormers, bay windows, etc. are not required to have access.
- Pull down stair treads, stringers, handrails, and hardware may protrude into the net clear area

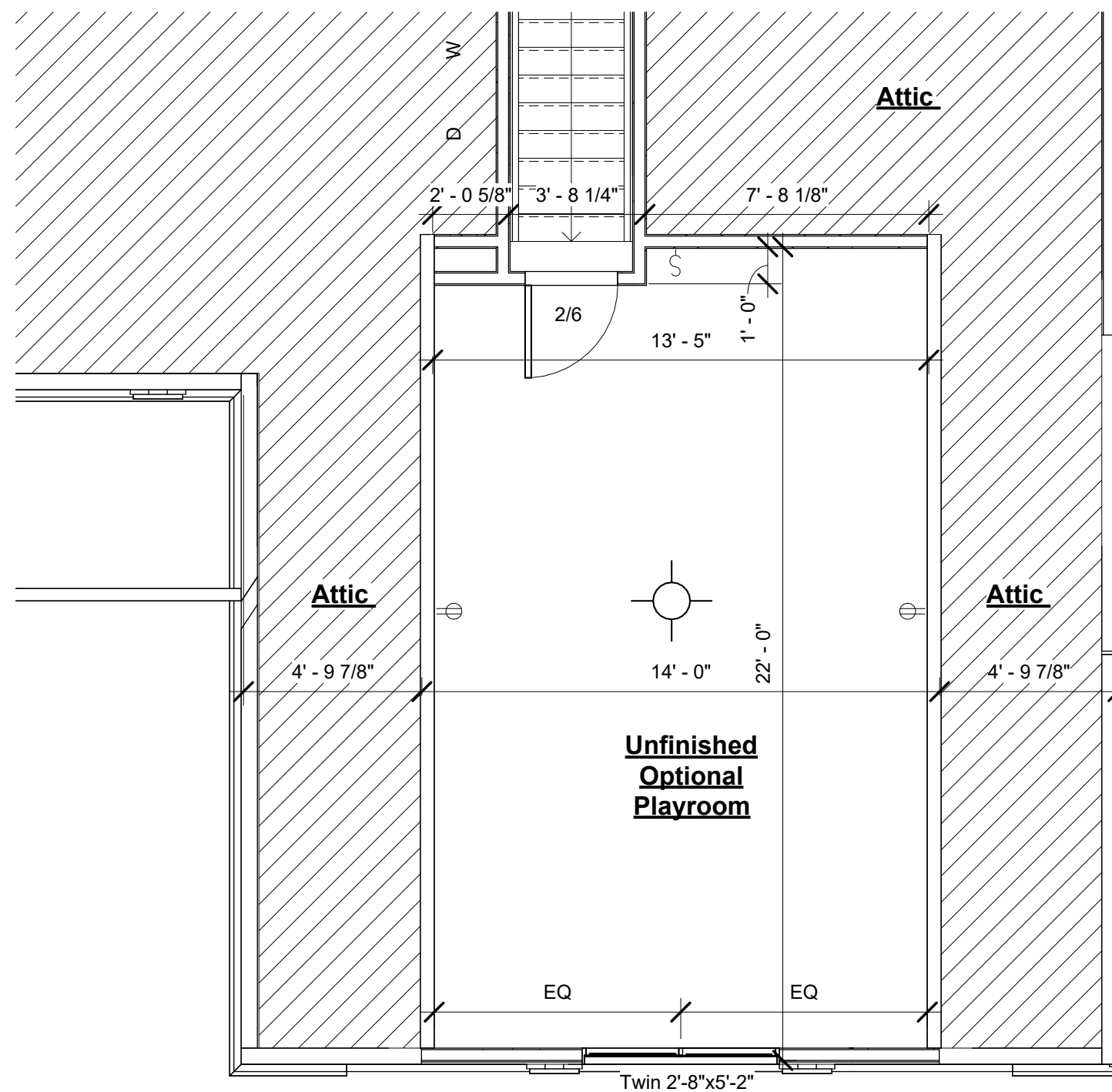

① Optional Bonus Room
1/4" = 1'-0"

IT IS THE SOLE RESPONSIBILITY OF THE CONTRACTOR AND/OR BUILDER TO CONFORM TO ALL STANDARDS, PROVISIONS, REQUIREMENTS, METHODS OF CONSTRUCTION AND USES OF MATERIALS, IN BUILDING CODES ANY OTHER LOCAL AGENCIES AND IN ACCORDANCE WITH GOOD ENGINEERING AND CONSTRUCTION PRACTICES.

I CERTIFY THAT THE CONSTRUCTION EXHIBITS FOR (IDENTIFICATION OF THE PROPERTY BY HOUSE TYPE, LOT, BLOCK, SUBDIVISION NAME, AND SO ON) MEET ALL LOCAL CODE REQUIREMENTS AND ARE IN SUBSTANTIAL CONFORMITY WITH BOTH SAH AND VA MINIMUM PROPERTY REQUIREMENTS. ALL BUILDING STANDARDS AS SET FORTH BY THE INTERNATIONAL CODE COUNCIL (ICC) AND FEDERAL SAFE DRINKING WATER PLUMBING STANDARD.

DESIGNED BY:

TIMOTHY PEPPERS JR.
RESIDENTIAL DESIGN
CONSULTANT

CAMERON
NORTH CAROLINA
(910) 644-4587

PROPERTY OF TPJR

DRAWINGS AND SPECIFICATIONS AS INSTRUMENTS OF SERVICE ARE AND SHALL REMAIN PROPERTY OF THE DESIGNER WHETHER THE PROJECT FOR WHICH THEY ARE MADE FOR IS EXECUTED OR NOT. THE DRAWINGS AND SPECIFICATIONS SHALL NOT BE USED BY THE OWNER ON OTHER PROJECTS FOR ADDITIONS TO THIS PROJECT OR FOR COMPLETION OF THIS PROJECT BY OTHERS EXCEPT BY AGREEMENT IN WRITING WITH THE APPROPRIATE COMPENSATION TO THE DESIGNER.

The Bellhaven
Weaver Development Co., Inc.
Bonus Room Plan

SCALE:

1/4" = 1'-0"

DATE:

March 22, 2024

Project number

070423000001

Drawn by

TP

Checked by

TP

Elevation Notes:

- Gutters and downspouts are not shown for clarity, downspouts shall be located towards the front and rear of the house. Locate downspouts in non-visually offensive locations. General contractor shall verify existing grades and coordinate any necessary drainage requirements with owner.
- Plumbing and HVAC vents shall be grouped in attic to limit roof penetrations and to be located away from public view and shall be primed and painted to match roof color where necessary.
- Provide attic ventilation per local code requirements.
- Exterior flashing shall be correctly installed at all connections between roofs, walls, chimneys, projections and penetrations as required by approved construction practices.
- Contractor shall provide adequate attic ventilations/roof vents per local governing code. Install continuous ridge ventilation and match to roof. Provide appropriate soffit ventilation at overhangs.

IT IS THE SOLE RESPONSIBILITY OF THE CONTRACTOR AND/OR BUILDER TO CONFORM TO ALL STANDARDS, PROVISIONS, REQUIREMENTS, METHODS OF CONSTRUCTION AND USES OF MATERIALS, IN BUILDING CODES AND OTHER LOCAL AGENCIES AND IN ACCORDANCE WITH GOOD ENGINEERING AND CONSTRUCTION PRACTICES.

I CERTIFY THAT THE CONSTRUCTION EXHIBITS FOR (IDENTIFICATION OF THE PROPERTY BY HOUSE TYPE, LOT, BLOCK, SUBDIVISION NAME, AND SO ON) MEET ALL LOCAL CODE REQUIREMENTS AND ARE IN SUBSTANTIAL CONFORMITY WITH BOTH SAH AND VA MINIMUM PROPERTY REQUIREMENTS. ALL BUILDING STANDARDS AS SET FORTH BY THE INTERNATIONAL CODE COUNCIL (ICC) AND FEDERAL SAFE DRINKING WATER PLUMBING STANDARD.

DESIGNED BY:
TIMOTHY PEPPERS JR.
RESIDENTIAL DESIGN
CONSULTANT
**CAMERON
NORTH CAROLINA
(910) 644-4587**

PROPERTY OF TPJR
DRAWINGS AND SPECIFICATIONS AS INSTRUMENTS OF SERVICE ARE AND SHALL REMAIN PROPERTY OF THE DESIGNER WHETHER THE PROJECT FOR WHICH THEY ARE MADE FOR IS EXECUTED OR NOT. THE DRAWINGS AND SPECIFICATIONS SHALL NOT BE USED BY THE OWNER ON OTHER PROJECTS OR FOR ADDITIONS TO THIS PROJECT OR FOR COMPLETION OF THIS PROJECT BY OTHERS EXCEPT BY AGREEMENT IN WRITING WITH THE APPROPRIATE COMPENSATION TO THE DESIGNER.

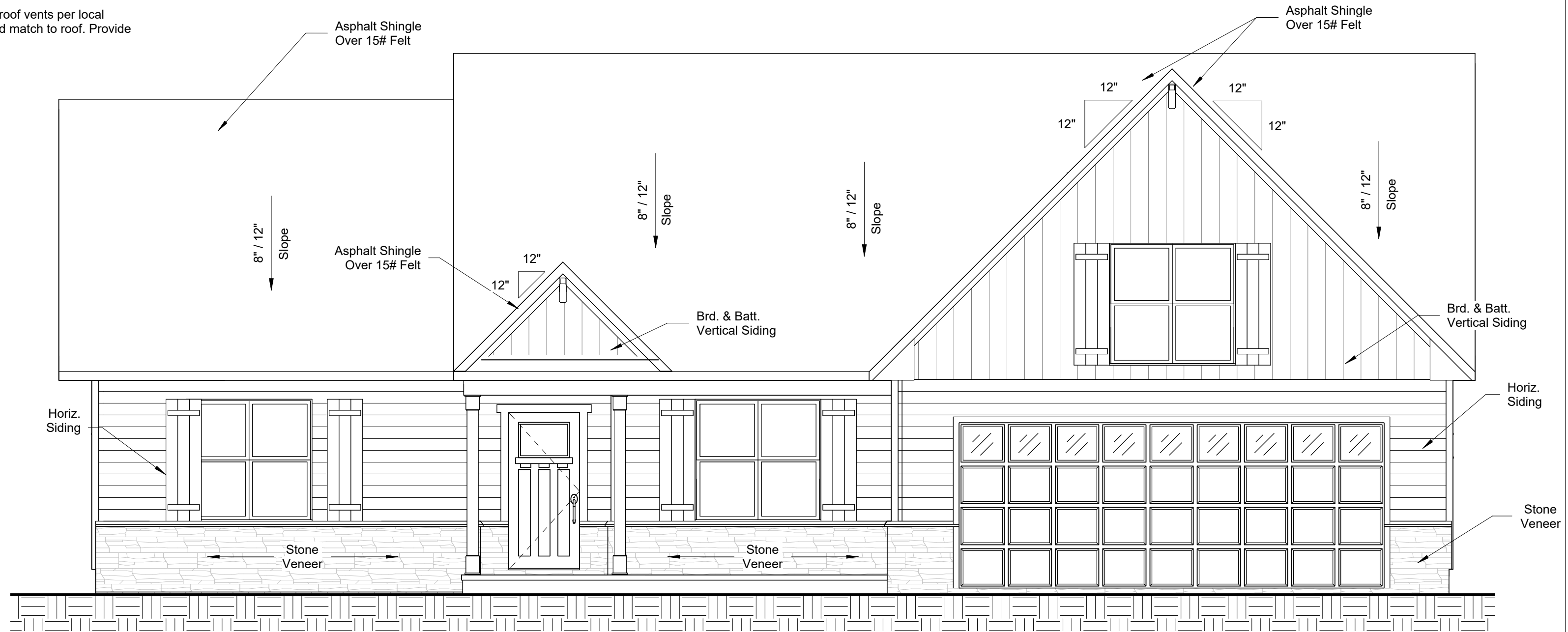

① Front
1/4" = 1'-0"

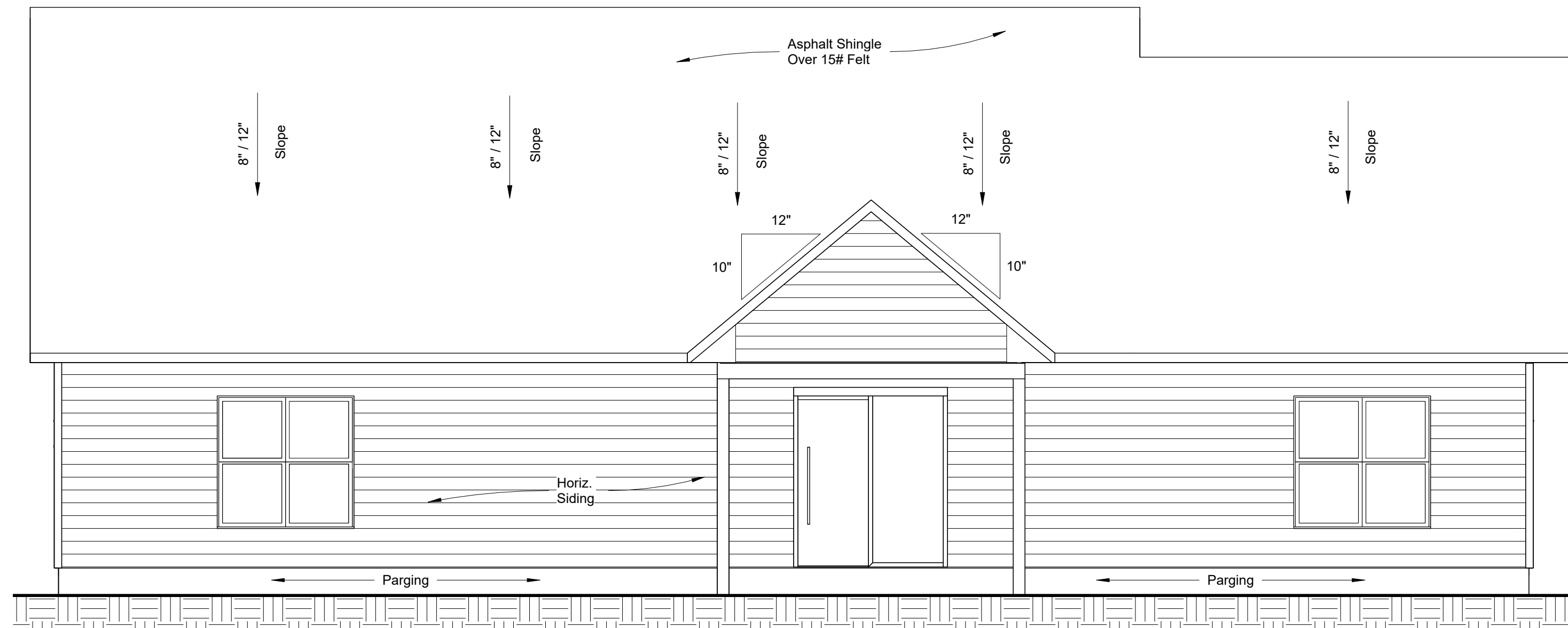

② Rear
1/4" = 1'-0"

**The Bellhaven
Weaver Development Co., Inc.
Elevations**

SCALE:
1/4" = 1'-0"

DATE:
March 22, 2024

Project number
070423000001

Drawn by TP
Checked by TP

IT IS THE SOLE RESPONSIBILITY OF THE CONTRACTOR AND/OR BUILDER TO CONFORM TO ALL STANDARDS, PROVISIONS, REQUIREMENTS, METHODS OF CONSTRUCTION AND USES OF MATERIALS, IN BUILDING CODES ANY OTHER LOCAL AGENCIES AND IN ACCORDANCE WITH GOOD ENGINEERING AND CONSTRUCTION PRACTICES.

I CERTIFY THAT THE CONSTRUCTION EXHIBITS FOR (IDENTIFICATION OF THE PROPERTY BY HOUSE TYPE, LOT, BLOCK, SUBDIVISION NAME, AND SO ON) MEET ALL LOCAL CODE REQUIREMENTS AND ARE IN SUBSTANTIAL CONFORMITY WITH BOTH SAH AND VA MINIMUM PROPERTY REQUIREMENTS. ALL BUILDING STANDARDS AS SET FORTH BY THE INTERNATIONAL CODE COUNCIL (ICC) AND FEDERAL SAFE DRINKING WATER PLUMBING STANDARD.

DESIGNED BY:
TIMOTHY PEPPERS JR.
RESIDENTIAL DESIGN
CONSULTANT
**CAMERON
NORTH CAROLINA
(910) 644-4587**

PROPERTY OF TPJR
DRAWINGS AND SPECIFICATIONS AS INSTRUMENTS OF SERVICE ARE AND SHALL REMAIN PROPERTY OF THE DESIGNER WHETHER THE PROJECT FOR WHICH THEY ARE MADE FOR IS EXECUTED OR NOT. THE DRAWINGS AND SPECIFICATIONS SHALL NOT BE USED BY THE OWNER ON OTHER PROJECTS FOR ADDITIONS TO THIS PROJECT OR FOR COMPLETION OF THIS PROJECT BY OTHERS EXCEPT BY AGREEMENT IN WRITING WITH THE APPROPRIATE COMPENSATION TO THE DESIGNER.

**The Bellhaven
Weaver Development Co., Inc.
Elevations (Cont.)**

SCALE:
1/4" = 1'-0"

DATE:
March 22, 2024

Project number
070423000001

Drawn by TP
Checked by TP

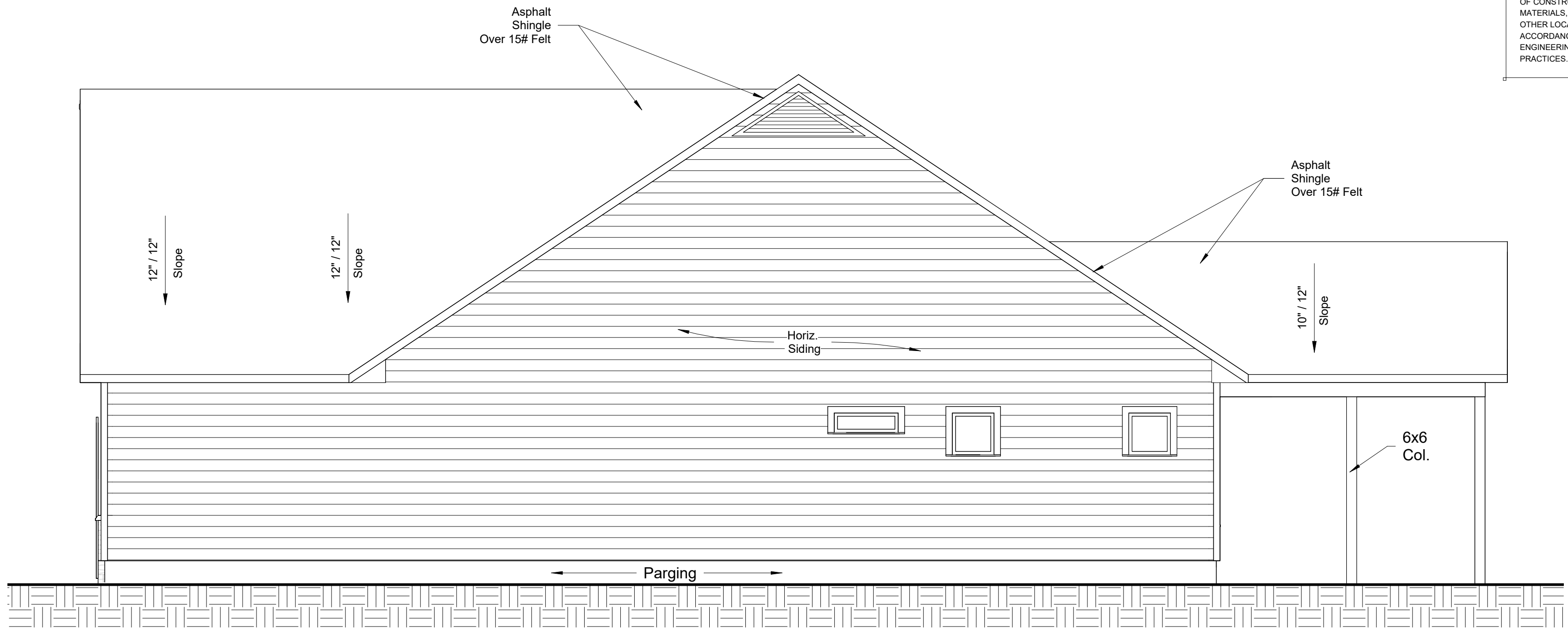

② Right
1/4" = 1'-0"

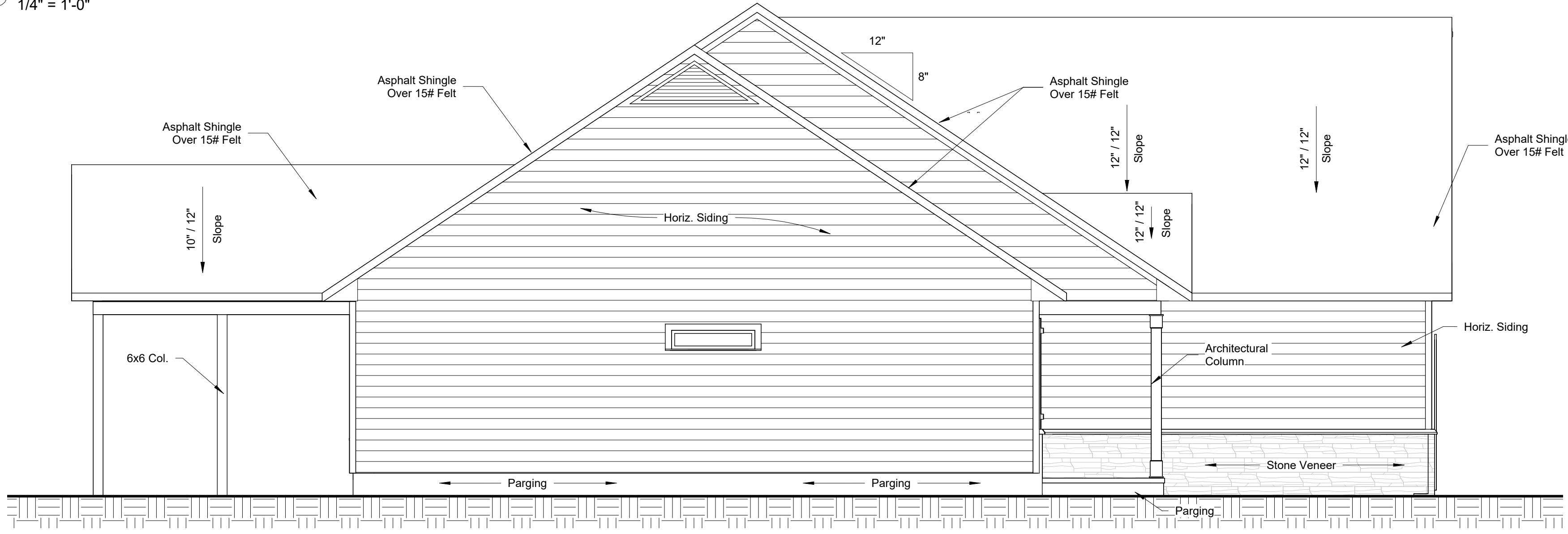

① Left
1/4" = 1'-0"

FOUNDATION NOTES:

- Concrete dimensions are typically to face of wall.
- All concrete slabs shall be minimum 4" thick, with 6 x 6 1.4/1.4 W.W.M welded wire fabric placed over 6 mil poly vapor barrier over a minimum 6" bed of compacted gravel.
- All portions of footings shall be placed on undisturbed soil. Footings or portions of footings placed on fill shall be engineered by others.
- All exterior footings shall be a minimum of 12" below finished grade. No footings shall be placed in water or on frozen soil.
- A minimum of 4" of compacted gravel shall be placed below all poured slabs.
- Dampproofing to be installed according to manufacturer's specifications.
- Provide Anchor Bolts sizes as indicated (min. 1/2" dia) on these drawings, at top of concrete foundation walls at a minimum of 1'-0" from corners and maximum 6'-0" O.C. for balance of perimeter walls, two per plate minimum.
- All concrete footings shall bear on undisturbed virgin soil with presumptive bearing capacity of 4000 psf.
- All concrete frost walls to have bottom of footing at minimum 1'-6" below finished grade.
- Concrete foundation walls that exceed 8'-0" in height must be reinforced with steel designed by a licensed Structural Engineer.
- All Concrete shall have the minimum 28 day strength:
 - Garage Slab 3500 psi
 - Basement Slab 3000 psi
 - Crawl Space Slab 3000 psi
 - Exterior Slab 3500 psi
 - Foundation Slab 3000 psi

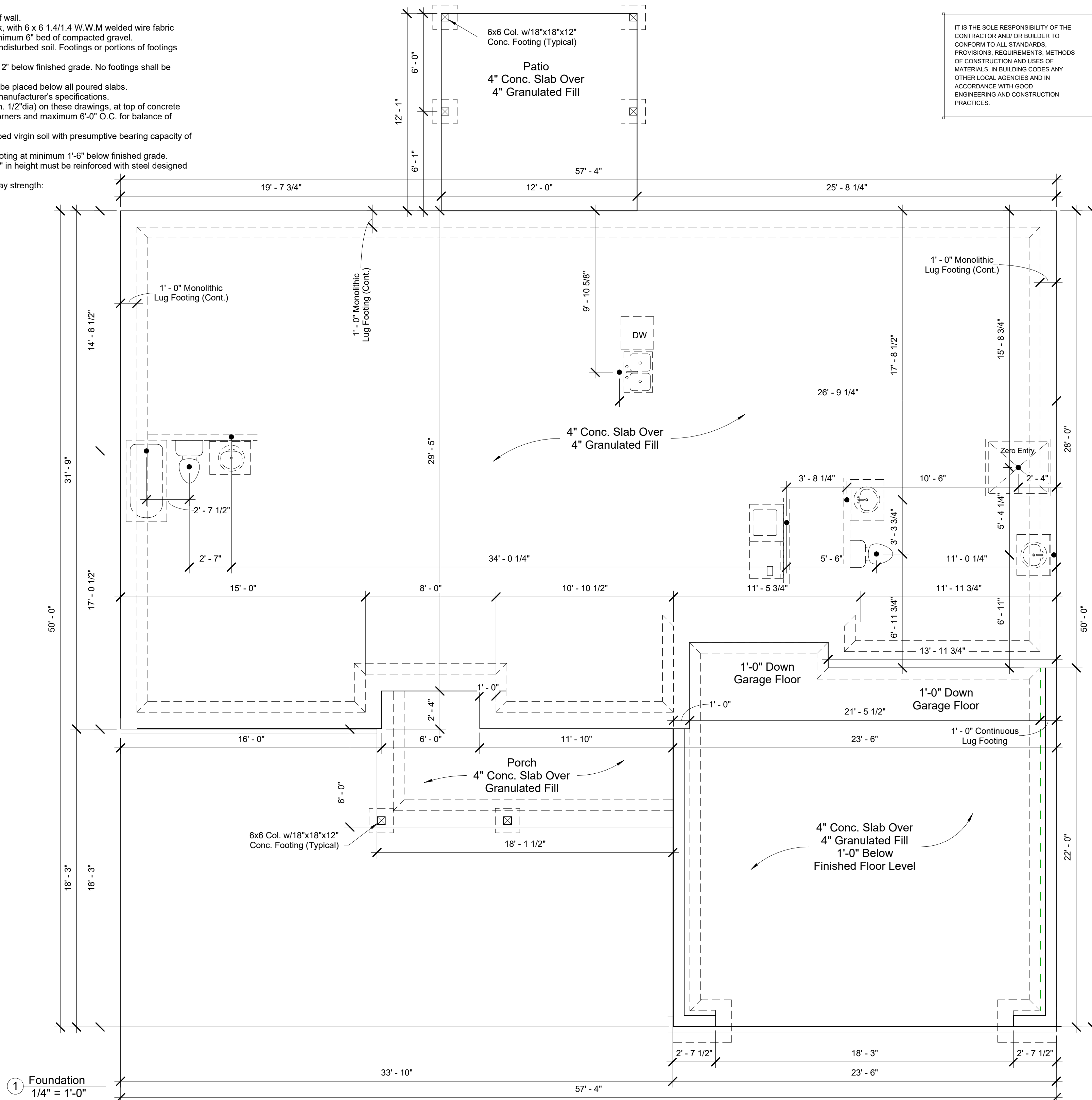

IT IS THE SOLE RESPONSIBILITY OF THE CONTRACTOR AND/OR BUILDER TO CONFORM TO ALL STANDARDS, PROVISIONS, REQUIREMENTS, METHODS OF CONSTRUCTION AND USES OF MATERIALS, IN BUILDING CODES ANY OTHER LOCAL AGENCIES AND IN ACCORDANCE WITH GOOD ENGINEERING AND CONSTRUCTION PRACTICES.

I CERTIFY THAT THE CONSTRUCTION EXHIBITS FOR (IDENTIFICATION OF THE PROPERTY BY HOUSE TYPE, LOT, BLOCK, SUBDIVISION NAME, AND SO ON) MEET ALL LOCAL CODE REQUIREMENTS AND ARE IN SUBSTANTIAL CONFORMITY WITH BOTH SAH AND VA MINIMUM PROPERTY REQUIREMENTS. ALL BUILDING STANDARDS AS SET FORTH BY THE INTERNATIONAL CODE COUNCIL (ICC) AND FEDERAL SAFE DRINKING WATER PLUMBING STANDARD.

DESIGNED BY:
TIMOTHY PEPPERS JR.
RESIDENTIAL DESIGN
CONSULTANT

CAMERON
NORTH CAROLINA
(910) 644-4587

PROPERTY OF TPJR
DRAWINGS AND SPECIFICATIONS AS INSTRUMENTS OF SERVICE ARE AND SHALL REMAIN PROPERTY OF THE DESIGNER WHETHER THE PROJECT FOR WHICH THEY ARE MADE FOR IS EXECUTED OR NOT. THE DRAWINGS AND SPECIFICATIONS SHALL NOT BE USED BY THE OWNER ON OTHER PROJECTS FOR ADDITIONS TO THIS PROJECT OR FOR COMPLETION OF THIS PROJECT BY OTHERS EXCEPT BY AGREEMENT IN WRITING WITH THE APPROPRIATE COMPENSATION TO THE DESIGNER.

The Bellhaven
Weaver Development Co., Inc.
Foundation Plan

SCALE: 1/4" = 1'-0"

DATE: March 22, 2024

Project number: 070423000001

Drawn by: TP
Checked by: TP

① Foundation
1/4" = 1'-0"

IT IS THE SOLE RESPONSIBILITY OF THE CONTRACTOR AND/OR BUILDER TO CONFORM TO ALL STANDARDS, PROVISIONS, REQUIREMENTS, METHODS OF CONSTRUCTION AND USES OF MATERIALS, IN BUILDING CODES ANY OTHER LOCAL AGENCIES AND IN ACCORDANCE WITH GOOD ENGINEERING AND CONSTRUCTION PRACTICES.

I CERTIFY THAT THE CONSTRUCTION EXHIBITS FOR (IDENTIFICATION OF THE PROPERTY BY HOUSE TYPE, LOT, BLOCK, SUBDIVISION NAME, AND SO ON) MEET ALL LOCAL CODE REQUIREMENTS AND ARE IN SUBSTANTIAL CONFORMITY WITH BOTH SAH AND VA MINIMUM PROPERTY REQUIREMENTS. ALL BUILDING STANDARDS AS SET FORTH BY THE INTERNATIONAL CODE COUNCIL (ICC) AND FEDERAL SAFE DRINKING WATER PLUMBING STANDARD.

DESIGNED BY:
TIMOTHY PEPPERS JR.
RESIDENTIAL DESIGN
CONSULTANT

CAMERON
NORTH CAROLINA
(910) 644-4587

PROPERTY OF TPJR
DRAWINGS AND SPECIFICATIONS AS INSTRUMENTS OF SERVICE ARE AND SHALL REMAIN PROPERTY OF THE DESIGNER WHETHER THE PROJECT FOR WHICH THEY ARE MADE FOR IS EXECUTED OR NOT. THE DRAWINGS AND SPECIFICATIONS SHALL NOT BE USED BY THE OWNER ON OTHER PROJECTS FOR ADDITIONS TO THIS PROJECT OR FOR COMPLETION OF THIS PROJECT BY OTHERS EXCEPT BY AGREEMENT IN WRITING WITH THE APPROPRIATE COMPENSATION TO THE DESIGNER.

The Bellhaven
Weaver Development Co., Inc.
Roof Plan

SCALE:
1/4" = 1'-0"

DATE:
March 22, 2024

Project number
070423000001

Drawn by TP
Checked by TP

6

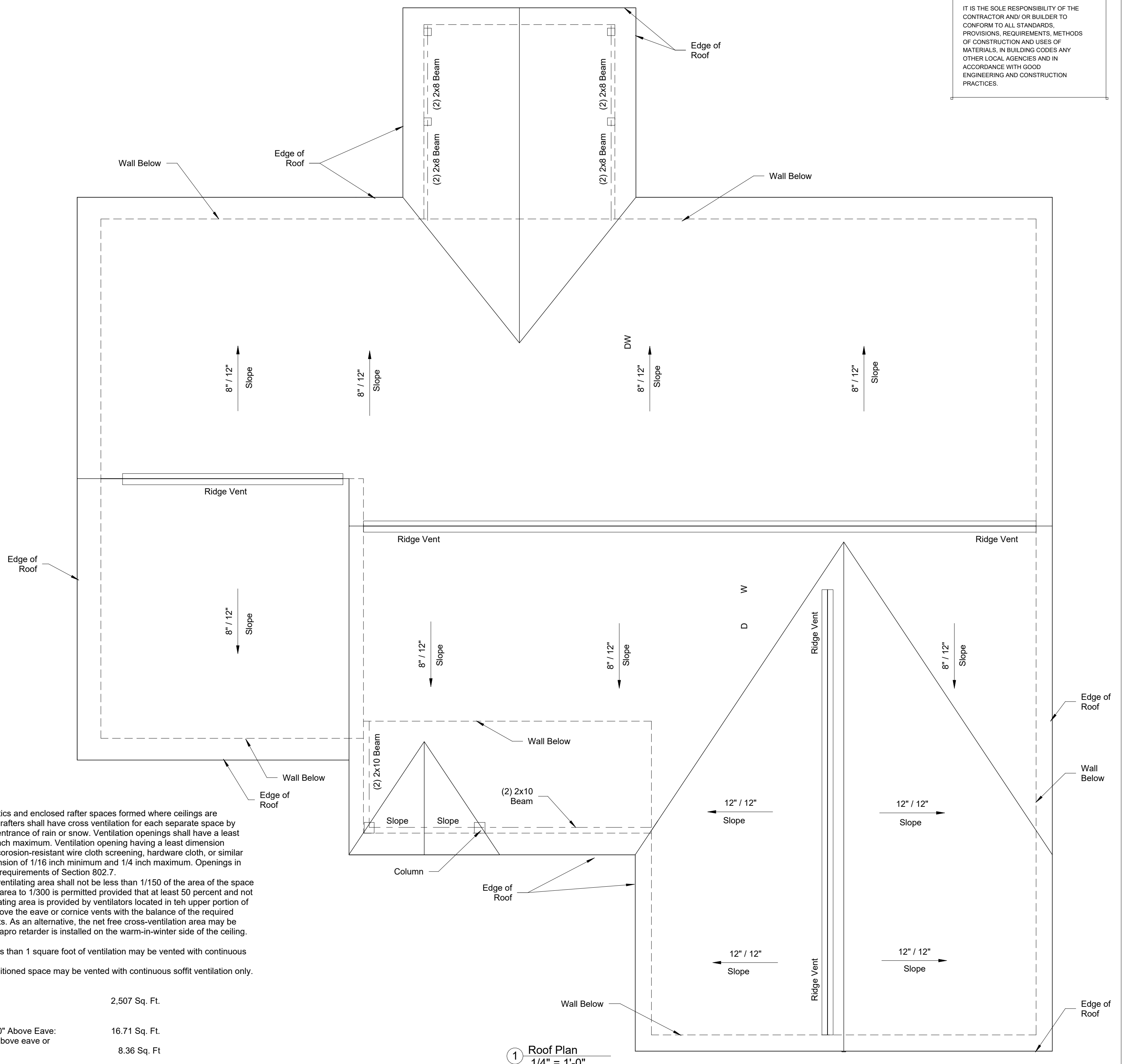

Roofing Ventilation Section R806

R806.1 Ventilation Required. Enclosed attics and enclosed rafter spaces formed where ceilings are applied directly to the underside of the roof rafters shall have cross ventilation for each separate space by ventilating openings protected against the entrance of rain or snow. Ventilating openings shall have a least dimension of 1/16 inch minimum and 1/4 inch maximum. Ventilating opening having a least dimension larger than 1/4 inch shall be provided with corrosion-resistant wire cloth screening, hardware cloth, or similar material with openings having a least dimension of 1/16 inch minimum and 1/4 inch maximum. Openings in roof framing members shall conform to the requirements of Section 802.7.

R806.2 Minimum Area. The total net free ventilating area shall not be less than 1/150 of the area of the space ventilated except that reduction of the total area to 1/300 is permitted provided that at least 50 percent and not more than 80 percent of the required ventilating area is provided by ventilators located in the upper portion of the space to be ventilated at least 3 feet above the eave or cornice vents with the balance of the required ventilation provided by eave or cornice vents. As an alternative, the net free cross-ventilation area may be reduced to 1/300 when Class I or Class II vapor retarder is installed on the warm-in-winter side of the ceiling.

- Exceptions:**
1. Enclosed attic/rafter spaces requiring less than 1 square foot of ventilation may be vented with continuous soffit ventilation only.
 2. Enclosed attic/rafter spaces over unconditioned space may be vented with continuous soffit ventilation only.

Square Footage Being Ventilated: 2,507 Sq. Ft.

Net Free Cross Ventilation Needed:

- Without 50% to 80% of venting 3'-0" Above Eave: 16.71 Sq. Ft.
- With 50% to 80% of venting 3'-0" above eave or Class I or Class II Vapor Retarder : 8.36 Sq. Ft

1 Roof Plan
1/4" = 1'-0"

Structural Notes

All construction shall conform to the latest requirements of the 2018 North Carolina Residential Building Code, plus all local codes and regulations. This document in no way shall be construed to supersede the code.

Job Site Practice and Safety. The designer assumes no liability for contractor practices and procedures or safety plan. The designer takes no responsibility for failure to carry out construction work in accordance with contract documents. All members shall be framed, anchored, and braced in accordance with good construction safety practices and according to the code.

Roof Truss Requirements

Truss Design. Trusses to be designed and engineered in accordance with these drawings. Any variation with these drawings must be brought to the Designer's attention prior to commencing construction.

Knee Wall and Ceiling Heights. All finished knee wall heights and ceiling heights are shown furred down 10" from the decking for the insulation. If for any reason the truss manufacturer fails to meet or exceed designated heel heights, finished knee wall heights of finished ceiling heights shown on these plans the finished square footage may vary. Any discrepancies must be brought to the attention of the designer for a suitable solution prior to commencing construction.

Anchorage. All required anchors for trusses due to uplift or bearing shall meet the requirements as specified by the truss manufacturer's schematics.

Bearing. All trusses shall be designed for bearing on SPF #2 plates or ledgers unless otherwise noted.

Plate Heights & Floor Systems. See Elevations and Sections for plate heights and floor thicknesses.

IT IS THE SOLE RESPONSIBILITY OF THE CONTRACTOR AND/OR BUILDER TO CONFORM TO ALL STANDARDS, PROVISIONS, REQUIREMENTS, METHODS OF CONSTRUCTION AND USES OF MATERIALS, IN BUILDING CODES ANY OTHER LOCAL AGENCIES AND IN ACCORDANCE WITH GOOD ENGINEERING AND CONSTRUCTION PRACTICES.

I CERTIFY THAT THE CONSTRUCTION EXHIBITS FOR (IDENTIFICATION OF THE PROPERTY BY HOUSE TYPE, LOT, BLOCK, SUBDIVISION NAME, AND SO ON) MEET ALL LOCAL CODE REQUIREMENTS AND ARE IN SUBSTANTIAL CONFORMITY WITH BOTH SAH AND VA MINIMUM PROPERTY REQUIREMENTS. ALL BUILDING STANDARDS AS SET FORTH BY THE INTERNATIONAL CODE COUNCIL (ICC) AND FEDERAL SAFE DRINKING WATER PLUMBING STANDARD.

DESIGNED BY:
TIMOTHY PEPPERS JR.
RESIDENTIAL DESIGN
CONSULTANT

CAMERON
NORTH CAROLINA
(910) 644-4587

PROPERTY OF TPJR

DRAWINGS AND SPECIFICATIONS AS INSTRUMENTS OF SERVICE ARE AND SHALL REMAIN PROPERTY OF THE DESIGNER WHETHER THE PROJECT FOR WHICH THEY ARE MADE FOR IS EXECUTED OR NOT. THE DRAWINGS AND SPECIFICATIONS SHALL NOT BE USED BY THE OWNER ON OTHER PROJECTS FOR ADDITIONS TO THIS PROJECT OR FOR COMPLETION OF THIS PROJECT BY OTHERS EXCEPT BY AGREEMENT IN WRITING WITH THE APPROPRIATE COMPENSATION TO THE DESIGNER.

The Bellhaven
Weaver Development Co., Inc.
Structural Plan

SCALE:
1/4" = 1'-0"

DATE:
March 22, 2024

Project number
070423000001

Drawn by TP
Checked by TP

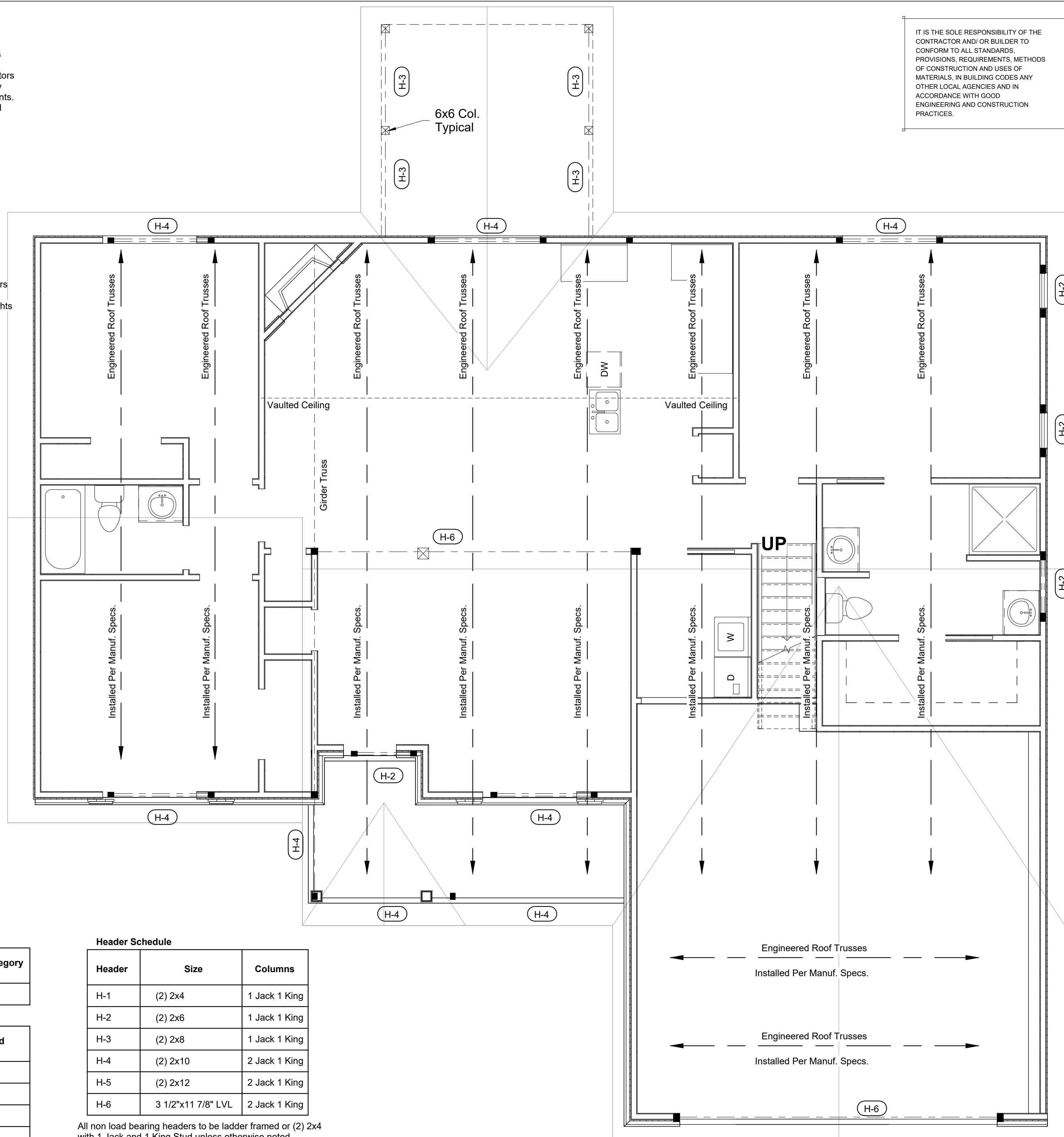

Brace Wall Factors

Max Eave to Ridge	Wind Speed	Exposure	Seismic Category
13'-0"	110	B	A or B

Rectangle A

Side	Perp. Distance	Required	Provided
1	40'-0"	18'-2"	24'-8"
2	40'-0"	18'-2"	19'-8"
3	39'-0"	17'-9"	25'-3"
4	39'-0"	17'-9"	34'-2"
Wall Height: 9'-0"		Roof +1	Eave: 13'-0"

Header Schedule

Header	Size	Columns
H-1	(2) 2x4	1 Jack 1 King
H-2	(2) 2x6	1 Jack 1 King
H-3	(2) 2x8	1 Jack 1 King
H-4	(2) 2x10	2 Jack 1 King
H-5	(2) 2x12	2 Jack 1 King
H-6	3 1/2"x11 7/8" LVL	2 Jack 1 King

All non load bearing headers to be ladder framed or (2) 2x4 with 1 Jack and 1 King Stud unless otherwise noted

1 Structural Plan
1/4" = 1'-0"

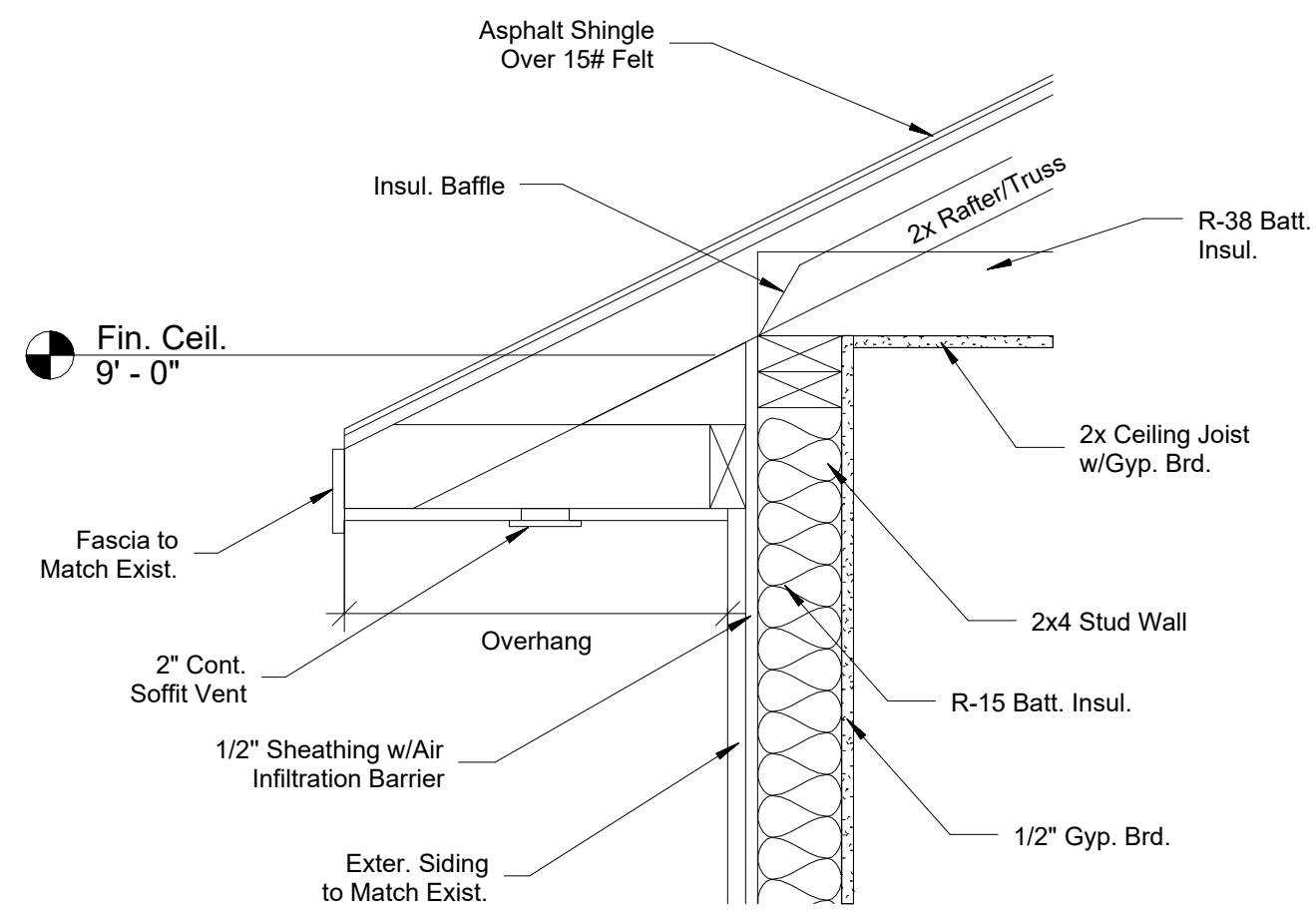

1 Cornice Detail
1 1/2" = 1'-0"

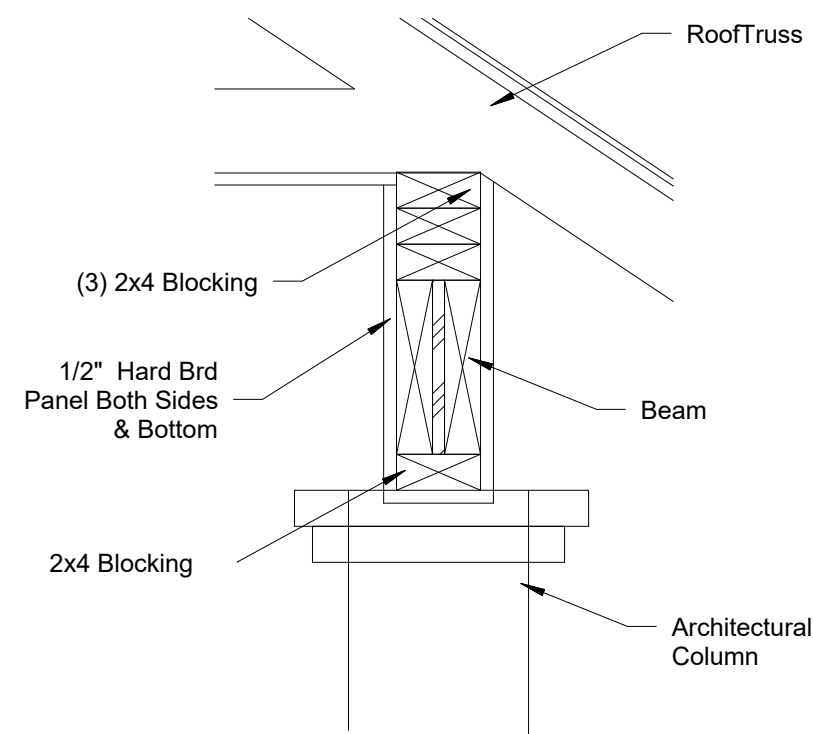

2 Porch Header Detail
1 1/2" = 1'-0"

IT IS THE SOLE RESPONSIBILITY OF THE CONTRACTOR AND/OR BUILDER TO CONFORM TO ALL STANDARDS, PROVISIONS, REQUIREMENTS, METHODS OF CONSTRUCTION AND USES OF MATERIALS, IN BUILDING CODES ANY OTHER LOCAL AGENCIES AND IN ACCORDANCE WITH GOOD ENGINEERING AND CONSTRUCTION PRACTICES.

I CERTIFY THAT THE CONSTRUCTION EXHIBITS FOR (IDENTIFICATION OF THE PROPERTY BY HOUSE TYPE, LOT, BLOCK, SUBDIVISION NAME, AND SO ON) MEET ALL LOCAL CODE REQUIREMENTS AND ARE IN SUBSTANTIAL CONFORMITY WITH BOTH SAH AND VA MINIMUM PROPERTY REQUIREMENTS. ALL BUILDING STANDARDS AS SET FORTH BY THE INTERNATIONAL CODE COUNCIL (ICC) AND FEDERAL SAFE DRINKING WATER PLUMBING STANDARD.

DESIGNED BY:
TIMOTHY PEPPERS JR.
RESIDENTIAL DESIGN CONSULTANT
CAMERON NORTH CAROLINA
(910) 644-4587

PROPERTY OF TPJR
DRAWINGS AND SPECIFICATIONS AS INSTRUMENTS OF SERVICE ARE AND SHALL REMAIN PROPERTY OF THE DESIGNER WHETHER THE PROJECT FOR WHICH THEY ARE MADE FOR IS EXECUTED OR NOT. THE DRAWINGS AND SPECIFICATIONS SHALL NOT BE USED BY THE OWNER ON OTHER PROJECTS FOR ADDITIONS TO THIS PROJECT OR FOR COMPLETION OF THIS PROJECT BY OTHERS EXCEPT BY AGREEMENT IN WRITING WITH THE APPROPRIATE COMPENSATION TO THE DESIGNER.

The Bellhaven
Weaver Development Co., Inc.
Sections & Details (Cont.)

SCALE:
As indicated

DATE:
March 22, 2024

Project number
070423000001

Drawn by TP
Checked by TP

9

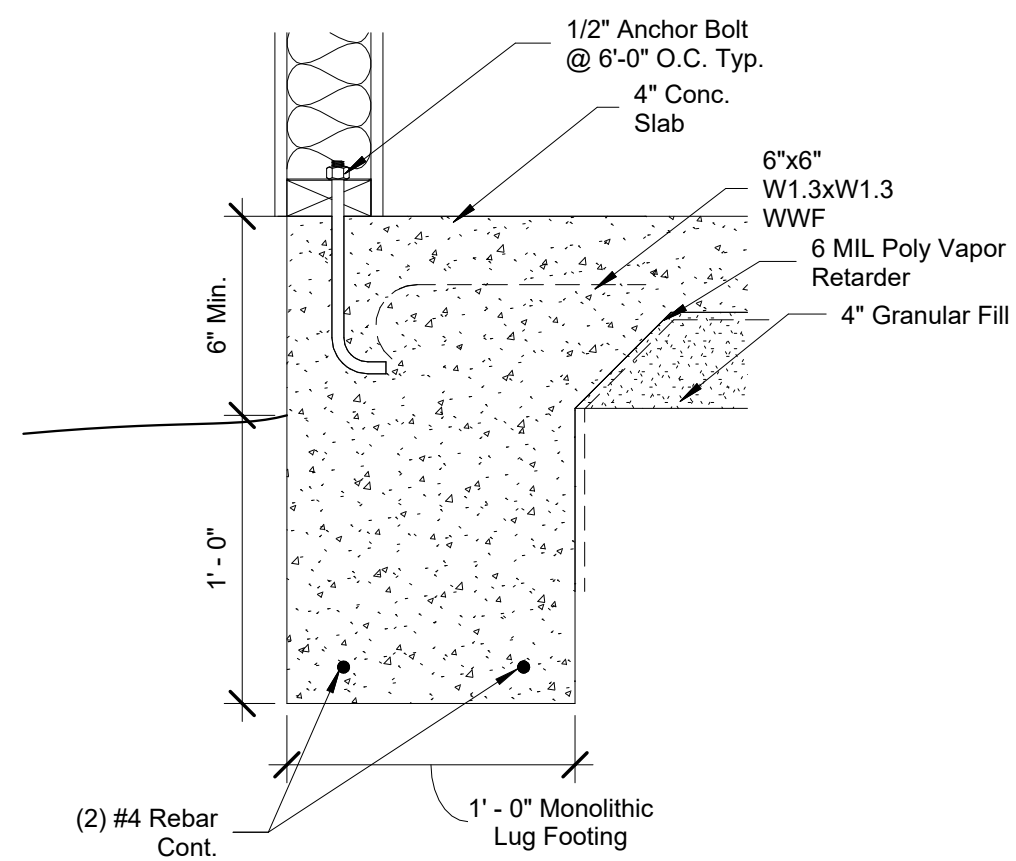

Monolithic Lug Footing

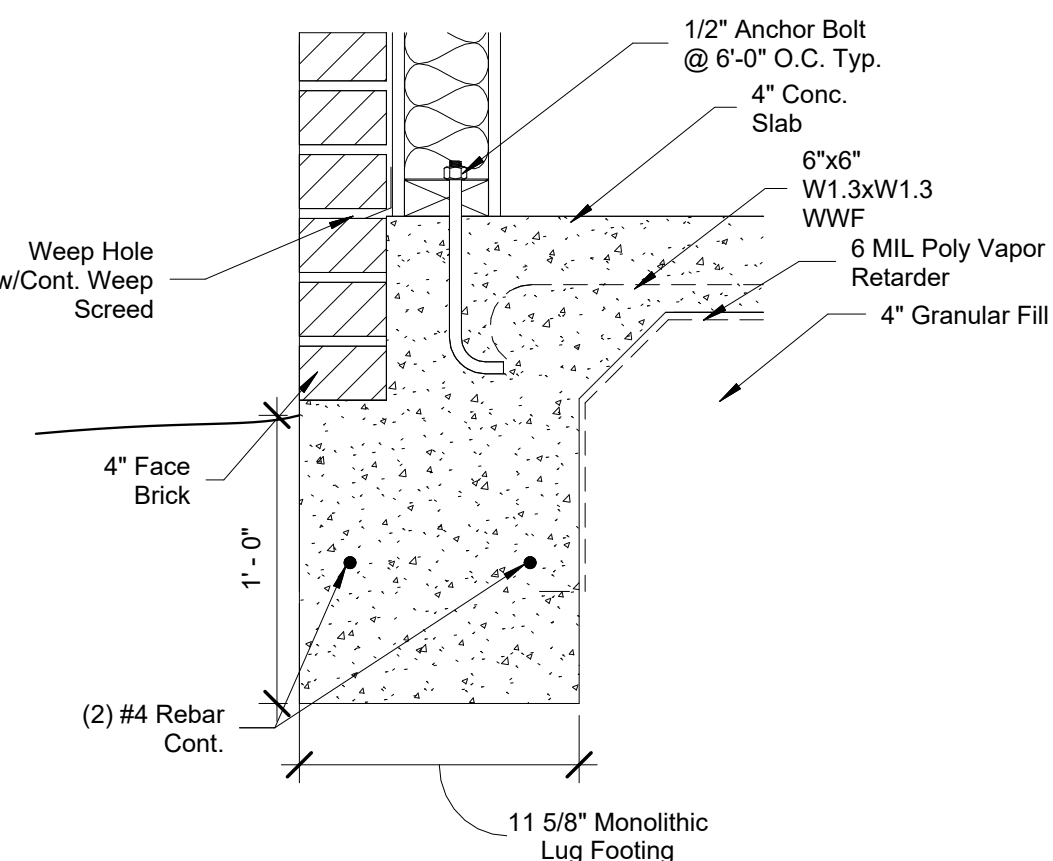

Monolithic Lug Footing w/Brick or Masonry Veneer

3 Lug Footing Detail
1 1/2" = 1'-0"

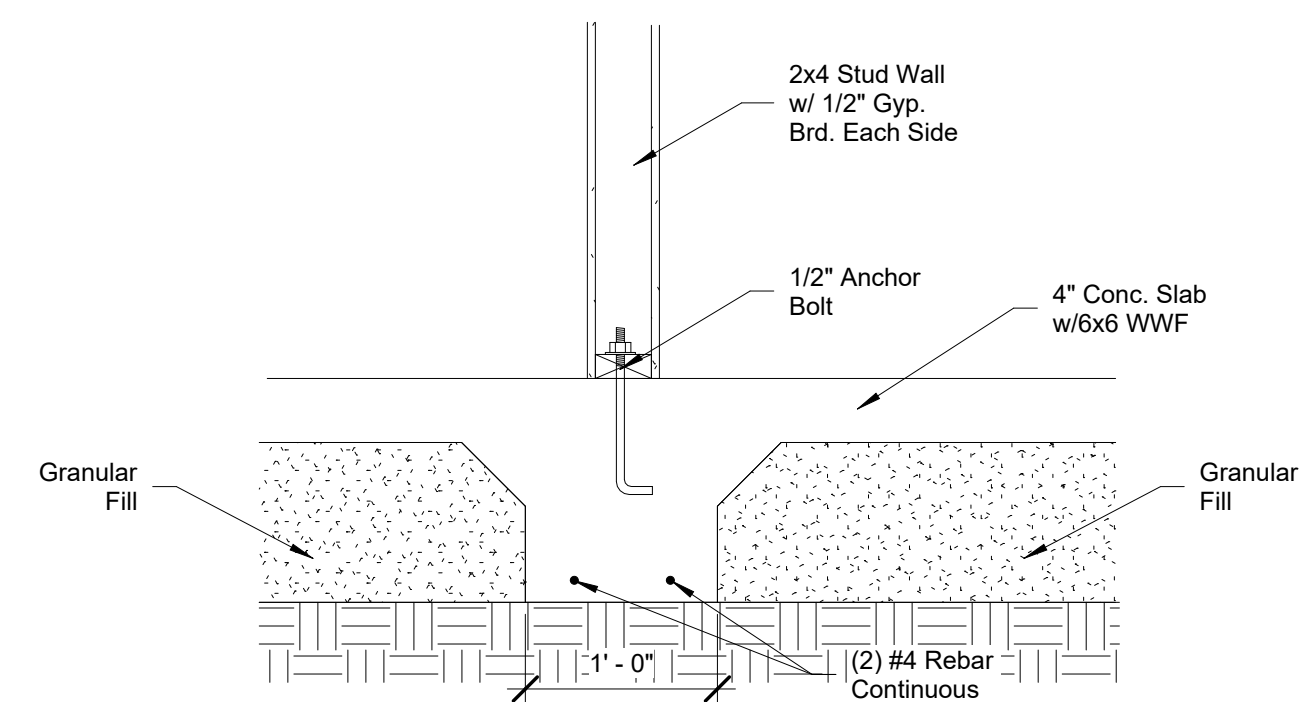

4 Integral Lug Footing Detail
1" = 1'-0"

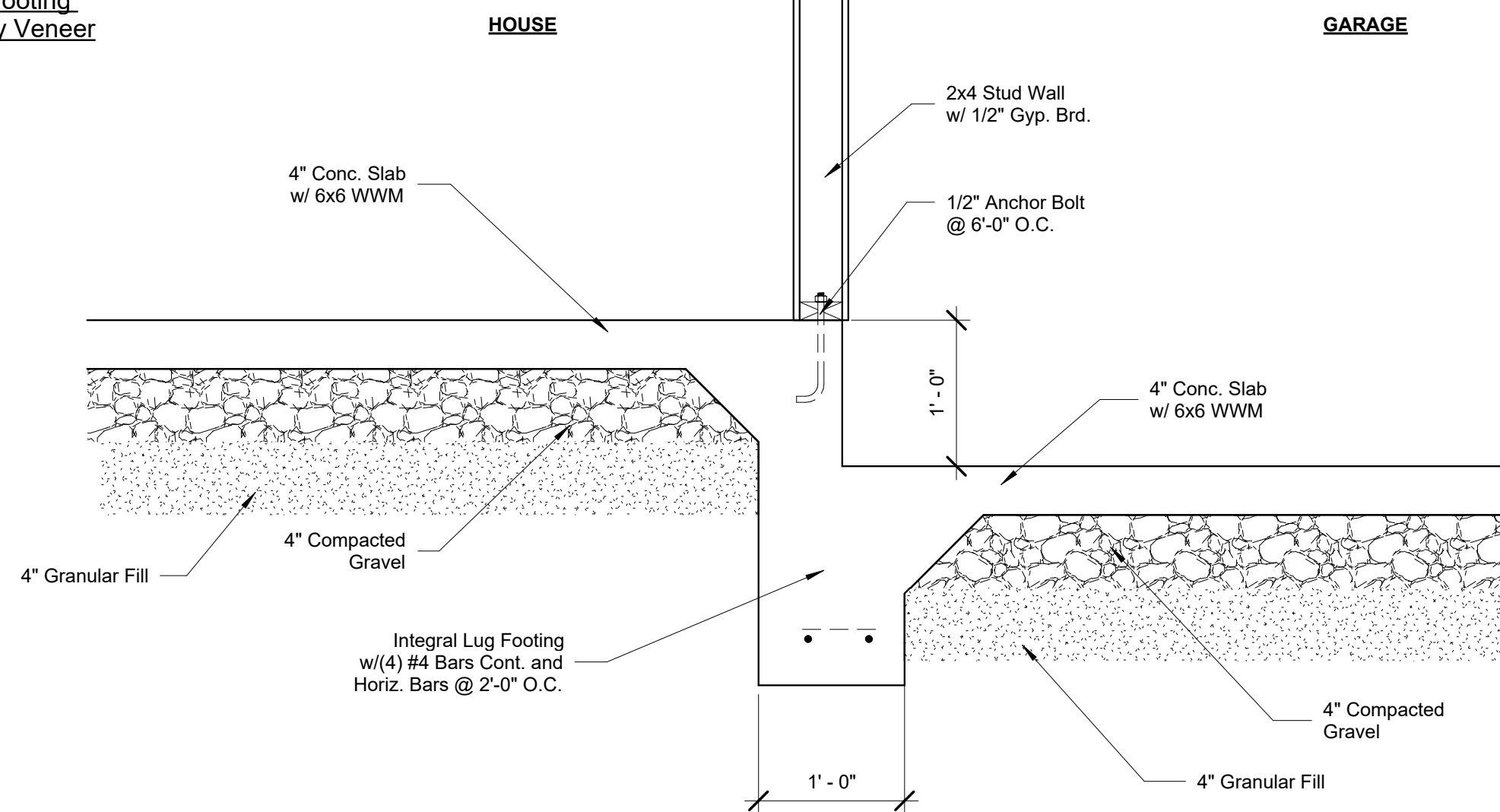

5 Integral Lug Footing Detail - Garage
1" = 1'-0"



ROOF & FLOOR TRUSSES & BEAMS

Reilly Road Industrial Park
Fayetteville, N.C. 28309
Phone: (910) 864-8787
Fax: (910) 864-4444

Bearing reactions less than or equal to 3000# are deemed to comply with the prescriptive Code requirements. The contractor shall refer to the attached Tables (derived from the prescriptive Code requirements) to determine the minimum foundation size and number of wood studs required to support reactions greater than 3000# but not greater than 15000#. A registered design professional shall be retained to design the support system for any reaction that exceeds those specified in the attached Tables. A registered design professional shall be retained to design the support system for all reactions that exceed 15000#.

Signature Lenny Norris
Lenny Norris

LOAD CHART FOR JACK STUDS

(BASED ON TABLES R502.5(1) & (b))
NUMBER OF JACK STUDS REQUIRED @ EA END OF HEADER/GIRDER

END REACTION (UP TO)	REQ. STUDS FOR (1) PLY HEADER	END REACTION (UP TO)	REQ. STUDS FOR (2) PLY HEADER	END REACTION (UP TO)	REQ. STUDS FOR (4) PLY HEADER
1700	1	2550	1	3400	1
3400	2	5100	2	6800	2
5100	3	7650	3	10200	3
6800	4	10200	4	13600	4
8500	5	12750	5	17000	5
10200	6	15300	6		
11900	7				
13600	8				
15300	9				

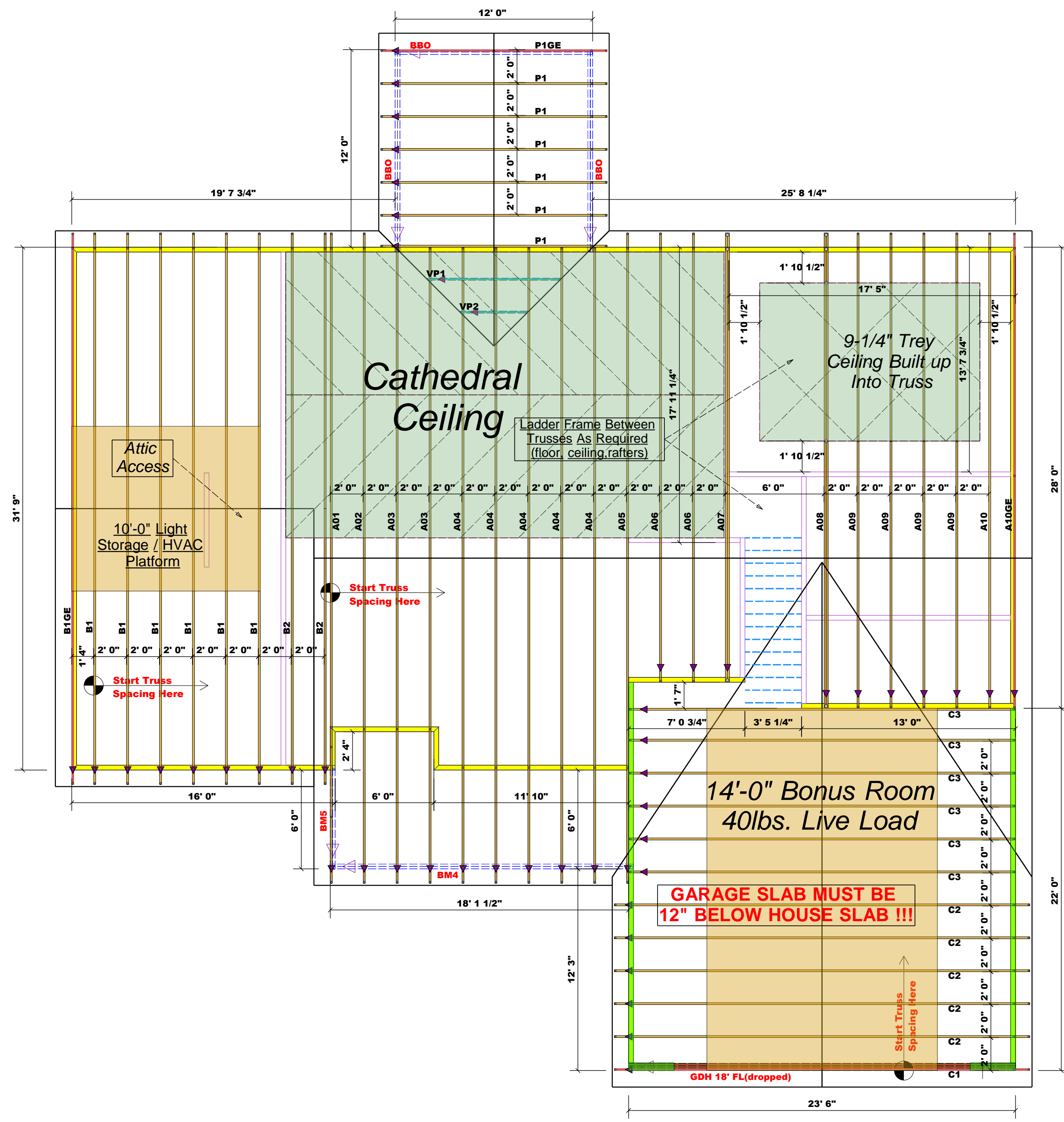

Hatch Legend

	= LOAD BEARING WALL HGT. @ 9-1-8
	= DROP GARAGE WALLS 1'-0" BELOW MAIN WALL HGT.

Estimation

Name	Selection	Formula	Calculation
Roof Area	1st Floor	Roof Area	3419.47
Roof Decking	1st Floor	Roof Decking	118

BEAM LEGEND

PlotID	Length	Product	Plies	Net Qty	Fab Type
GDH 18' FL(dropped)	24-00-00	1-3/4"x 11-7/8" LVL Kerto-S	3	3	FF

Truss Placement Plan

SCALE: 3/16" = 1'-0"

▲ = Denotes Left End of Truss
(Reference Engineered Truss Drawing)

All Truss Reactions are Less than 3,000 lbs. Unless Noted Otherwise.

○ -- Denotes Reaction Greater than 3,000 lbs. Reaction / # of Studs

BUILDER	CITY / CO.	Sanford / Harnett
WEAVER DEVELOPMENT, INC.	ADDRESS	Rhodes Rd.
JOB NAME	MODEL	ROOF
PLAN	DATE REV.	/ /
SEAL DATE	DRAWN BY	Lenny Norris
QUOTE #	SALES REP.	Lenny Norris
JOB #		J0724-4004

THIS IS A TRUSS PLACEMENT DIAGRAM ONLY. These trusses are designed as individual building components to be incorporated into the building design at the specification of the building designer. See individual design sheets for each truss design identified on the placement drawing. The building designer is responsible for temporary and permanent bracing of the roof and floor system and for the overall structure. The design of the truss support structure including headers, beams, walls, and columns is the responsibility of the building designer. For general guidance regarding bracing, consult BCSI-B1 and BCSI-B3 provided with the truss delivery package or online @ sbcindustry.com



ROOF & FLOOR TRUSSES & BEAMS

Reilly Road Industrial Park
Fayetteville, N.C. 28309
Phone: (910) 864-8787
Fax: (910) 864-4444

Bearing reactions less than or equal to 3000# are deemed to comply with the prescriptive Code requirements. The contractor shall refer to the attached Tables (derived from the prescriptive Code requirements) to determine the minimum foundation size and number of wood studs required to support reactions greater than 3000# but not greater than 15000#. A registered design professional shall be retained to design the support system for any reaction that exceeds those specified in the attached Tables. A registered design professional shall be retained to design the support system for all reactions that exceed 15000#.

Signature Lenny Norris
Lenny Norris

LOAD CHART FOR JACK STUDS

(BASED ON TABLES R502.5(1) & (b))
NUMBER OF JACK STUDS REQUIRED @ EA END OF HEADER/GIRDER

END REACTION (UP TO)	REQ. STUDS FOR (1) PLY HEADER	END REACTION (UP TO)	REQ. STUDS FOR (1) PLY HEADER	END REACTION (UP TO)	REQ. STUDS FOR (1) PLY HEADER
1700	1	2550	1	3400	1
3400	2	5100	2	6800	2
5100	3	7650	3	10200	3
6800	4	10200	4	13600	4
8500	5	12750	5	17000	5
10200	6	15300	6		
11900	7				
13600	8				
15300	9				

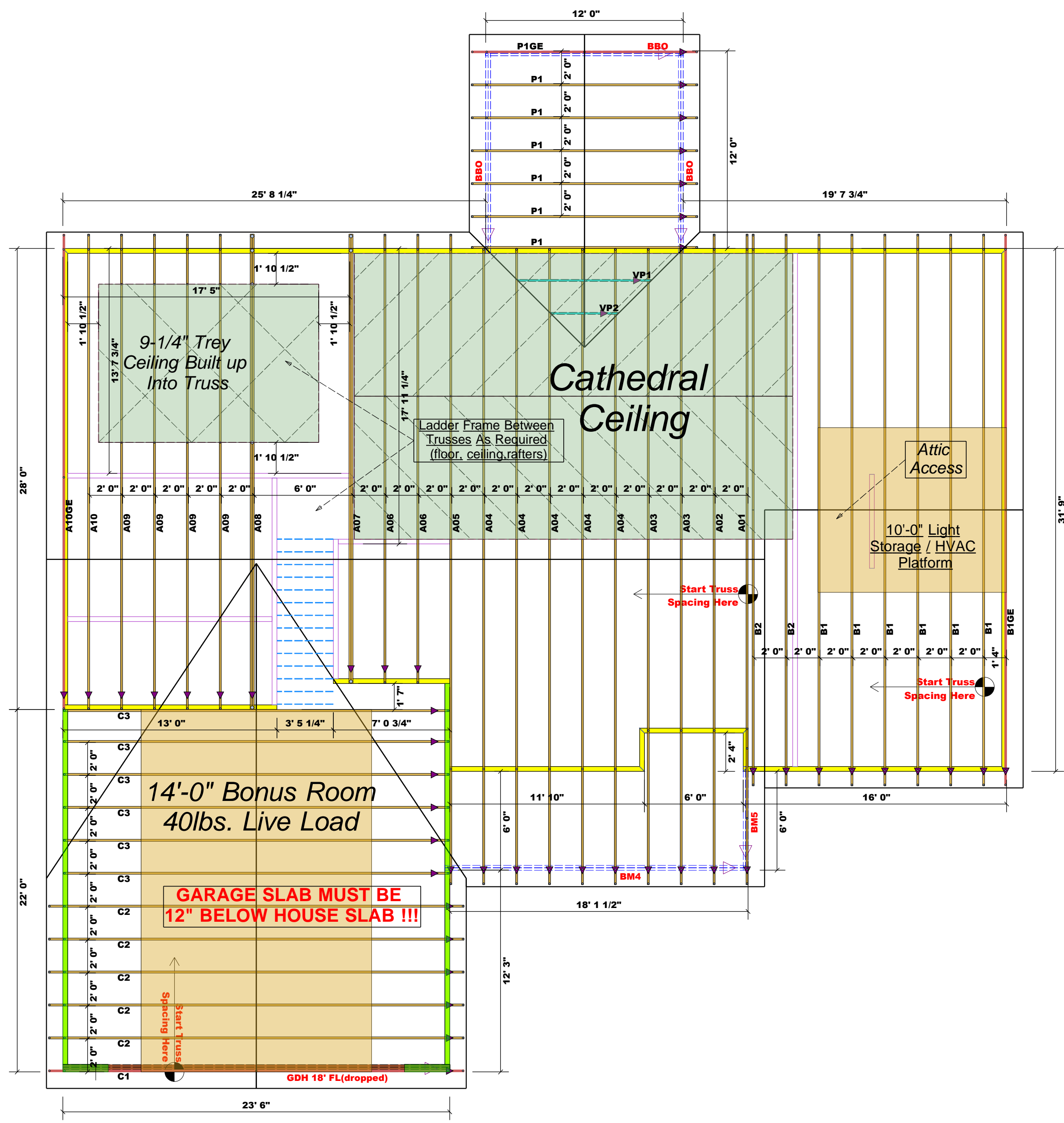

Hatch Legend

	= LOAD BEARING WALL HGT. @ 9-1-8
	= DROP GARAGE WALLS 1'-0" BELOW MAIN WALL HGT.

Estimation

Name	Selection	Formula	Calculation
Roof Area	1st Floor	Roof Area	3419.47
Roof Decking	1st Floor	Roof Decking	118

BEAM LEGEND

PlotID	Length	Product	Plies	Net Qty	Fab Type
GDH 18' FL(dropped)	24' 0"	1-3/4"x 11-7/8" LVL Kerto-S	3	3	FF

Truss Placement Plan

SCALE: 3/16" = 1'-0"

▲ = Denotes Left End of Truss
(Reference Engineered Truss Drawing)

All Truss Reactions are Less than 3,000 lbs. Unless Noted Otherwise.

○ -- Denotes Reaction Greater than 3,000 lbs. Reaction / # of Studs

WEAVER DEVELOPMENT, INC.	Sanford / Harnett	Sanford / Harnett	Sanford / Harnett	Sanford / Harnett	Sanford / Harnett
LOT 6 WEST PRESERVE	Rhodes Rd.	Rhodes Rd.	Rhodes Rd.	Rhodes Rd.	Rhodes Rd.
BELLHAVEN	ROOF	ROOF	ROOF	ROOF	ROOF
SEAL DATE	/ /	/ /	/ /	/ /	/ /
QUOTE #	B0123-0064	B0123-0064	B0123-0064	B0123-0064	B0123-0064
JOB #	J0724-4004	J0724-4004	J0724-4004	J0724-4004	J0724-4004

THIS IS A TRUSS PLACEMENT DIAGRAM ONLY. These trusses are designed as individual building components to be incorporated into the building design at the specification of the building designer. See individual design sheets for each truss design identified on the placement drawing. The building designer is responsible for temporary and permanent bracing of the roof and floor system and for the overall structure. The design of the truss support structure including headers, beams, walls, and columns is the responsibility of the building designer. For general guidance regarding bracing, consult BCSI-B1 and BCSI-B3 provided with the truss delivery package or online @ sbcindustry.com

GDH 18' FL Kerto-S LVL 1.750" X 11.875" 3-Ply - PASSED

Level: Level

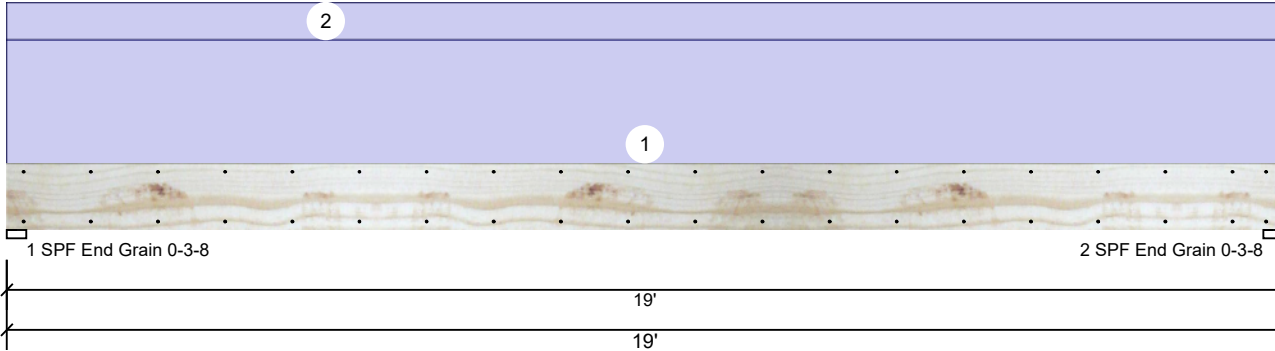

Member Information

Type:	Girder	Application:	Floor
Plies:	3	Design Method:	ASD
Moisture Condition:	Dry	Building Code:	IRC 2018
Deflection LL:	480	Load Sharing:	Yes
Deflection TL:	360	Deck:	Not Checked
Importance:	Normal - II		
Temperature:	Temp <= 100°F		

Reactions UNPATTERNED lb (Uplift)

Brg	Direction	Live	Dead	Snow	Wind	Const
1	Vertical	0	2602	0	0	0
2	Vertical	0	2602	0	0	0

Bearings

Bearing	Length	Dir.	Cap.	React D/L lb	Total	Ld. Case	Ld. Comb.
1 - SPF End Grain	3.500"	Vert	17%	2602 / 0	2602	Uniform	D
2 - SPF End Grain	3.500"	Vert	17%	2602 / 0	2602	Uniform	D

Analysis Results

Analysis	Actual	Location	Allowed	Capacity	Comb.	Case
Moment	11769 ft-lb	9'6"	27954 ft-lb	0.421 (42%)	D	Uniform
Unbraced	11769 ft-lb	9'6"	11788 ft-lb	0.998 (100%)	D	Uniform
Shear	2264 lb	1'3 3/8"	11970 lb	0.189 (19%)	D	Uniform
LL Defl inch	0.000 (L/999)	0	999.000 (L/0)	0.000 (0%)		
TL Defl inch	0.519 (L/429)	9'6 1/16"	0.618 (L/360)	0.839 (84%)	D	Uniform

Design Notes

- Provide support to prevent lateral movement and rotation at the end bearings. Lateral support may also be required at the interior bearings by the building code.
- Fasten all plies using 2 rows of 10d Box nails (.128x3") at 12" o.c. Maximum end distance not to exceed 6". Nail from both sides.
- Refer to last page of calculations for fasteners required for specified loads.
- Girders are designed to be supported on the bottom edge only.
- Top loads must be supported equally by all plies.
- Top must be laterally braced at a maximum of 12'2 7/8" o.c.
- Bottom must be laterally braced at end bearings.
- Lateral slenderness ratio based on single ply width.

ID	Load Type	Location	Trib Width	Side	Dead 0.9	Live 1	Snow 1.15	Wind 1.6	Const. 1.25	Comments
1	Uniform			Top	200 PLF	0 PLF	0 PLF	0 PLF	0 PLF	GABLE END
2	Uniform			Top	60 PLF	0 PLF	0 PLF	0 PLF	0 PLF	DEAD WALL
	Self Weight				14 PLF					

Notes

Calculated Structured Designs is responsible only of the structural adequacy of this component based on the design criteria and loadings shown. It is the responsibility of the customer and/or the contractor to ensure the component suitability of the intended application, and to verify the dimensions and loads.

Lumber

- Dry service conditions, unless noted otherwise
- LVL not to be treated with fire retardant or corrosive chemicals

Handling & Installation

- LVL beams must not be cut or drilled
- Refer to manufacturer's product information regarding installation requirements, multi-ply fastening details, beam strength values, and code approvals
- Damaged Beams must not be used
- Design assumes top edge is laterally restrained
- Provide lateral support at bearing points to avoid lateral displacement and rotation

6. For flat roofs provide proper drainage to prevent ponding

This design is valid until 6/28/2026

Manufacturer Info

Metsä Wood
 301 Merritt 7 Building, 2nd Floor
 Norwalk, CT 06851
 (800) 622-5850
 www.metsawood.com/us

