

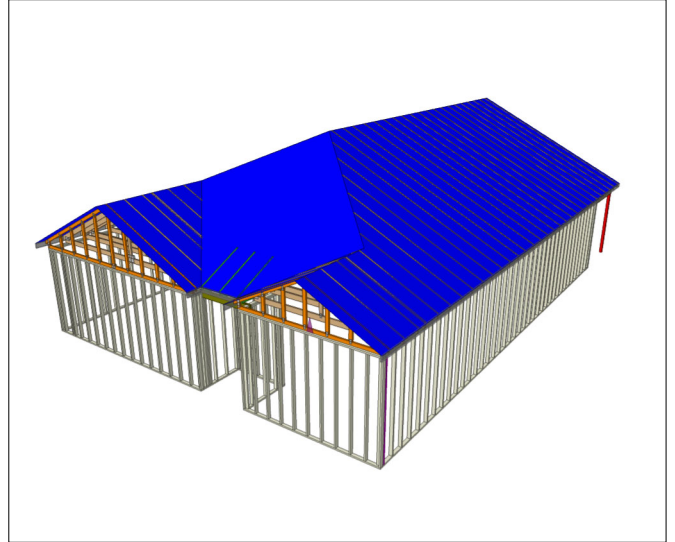

Kempsville Sanford Component Plant
298 Harvey Faulk Rd
Sanford, NC 27332

Phone #:919-775-1450

Builder: DR HORTON
Model: 43 Mason Ridge
Cali "M" LH



THE PLACEMENT PLAN NOTES:

1. The Placement Plan is a diagram for truss installation. It is not an engineered drawing and has not been reviewed by an engineer. The Owner/Building Designer is responsible for obtaining an engineer's review if one is required by the local jurisdiction.
2. The responsibilities of the Owner, Contractor, Building Designer, Component Designer and Component Manufacturer shall be as set forth in ANSI/TPI 1. Capitalized terms shall be as defined in ANSI/TP 1 unless otherwise indicated.
3. Each Component is designed as an individual component utilizing information provided by others. The Owner/Building Designer is responsible for reviewing all Component Submittal Packages and individual Component Design Drawings for compliance with the Construction Documents and compatibility with the overall Building design.
4. Contractor will not proceed with component installation until the Owner/Building Designer has reviewed the Component Submittal Package. Questions on the suitability of any Component will be resolved by the Building Designer.
5. The Building Designer and Contractor are responsible for all temporary and permanent bracing.
6. The Placement Plan assumes the building is dimensionally correct, structurally sound, and in a suitable condition to support each Component during installation and thereafter, including but not limited to installation of all bearing points. Proper design and construction of all structural components, including foundations, headers, beams, walls and columns are the responsibility of the Owner, Building Designer and Contractor.
7. Do not cut, drill, or modify any Component without first consulting the Component Manufacturer or Building Designer. Damaged Components shall not be installed unless directed by the Building Designer or approved by the Component Manufacturer.
8. Components must be handled and installed following all applicable safety standards and best practices, including but not limited to BCSI, OSHA, TPI and local codes. Failure to properly handle, brace or otherwise install Component can result in serious injury or death.

General Notes:

** CUTTING OR DRILLING OF COMPONENTS SHOULD NOT BE DONE WITHOUT CONTACTING COMPONENT SUPPLIER FIRST. CUSTOMER TAKES FULL RESPONSIBILITY FOR COMPONENTS IF CUT BEFORE AUTHORIZATION.

** ALL BEARING POINTS MUST BE INSTALLED PRIOR TO SETTING ANY COMPONENTS.

| Revisions | |
|-----------|------|
| 00/00/00 | Name |
| 00/00/00 | Name |
| 00/00/00 | Name |
| 00/00/00 | Name |
| 00/00/00 | Name |

THIS IS A TRUSS PLACEMENT DIAGRAM ONLY. These trusses are designed as individual components to be incorporated into the building design at the specification of the building designer. See individual design sheets for each truss design identified on the placement drawing. The building designer is responsible for temporary and permanent bracing of the roof and floor systems and for the overall structure. The design of the truss support structure including headers, beams, walls, and columns is the responsibility of the building designer. For general guidance regarding the bracing, consult "Bracing of Wood Trusses" available from the Truss Plate Institute, 583 D'Onofrio Drive, Madison, WI 53179



DR Horton Inc
43 Mason Ridge-Roof-Cali M
VMB GLH
ROOF PLACEMENT PLAN

Scale: **NTS**
 Date: **8/2/2024**
 Designer:
Nate Donaldson
 Project Number:
24070189-01
 Sheet Number:

1/1

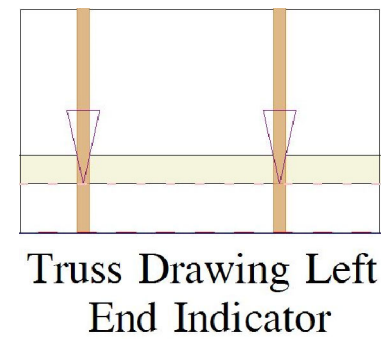
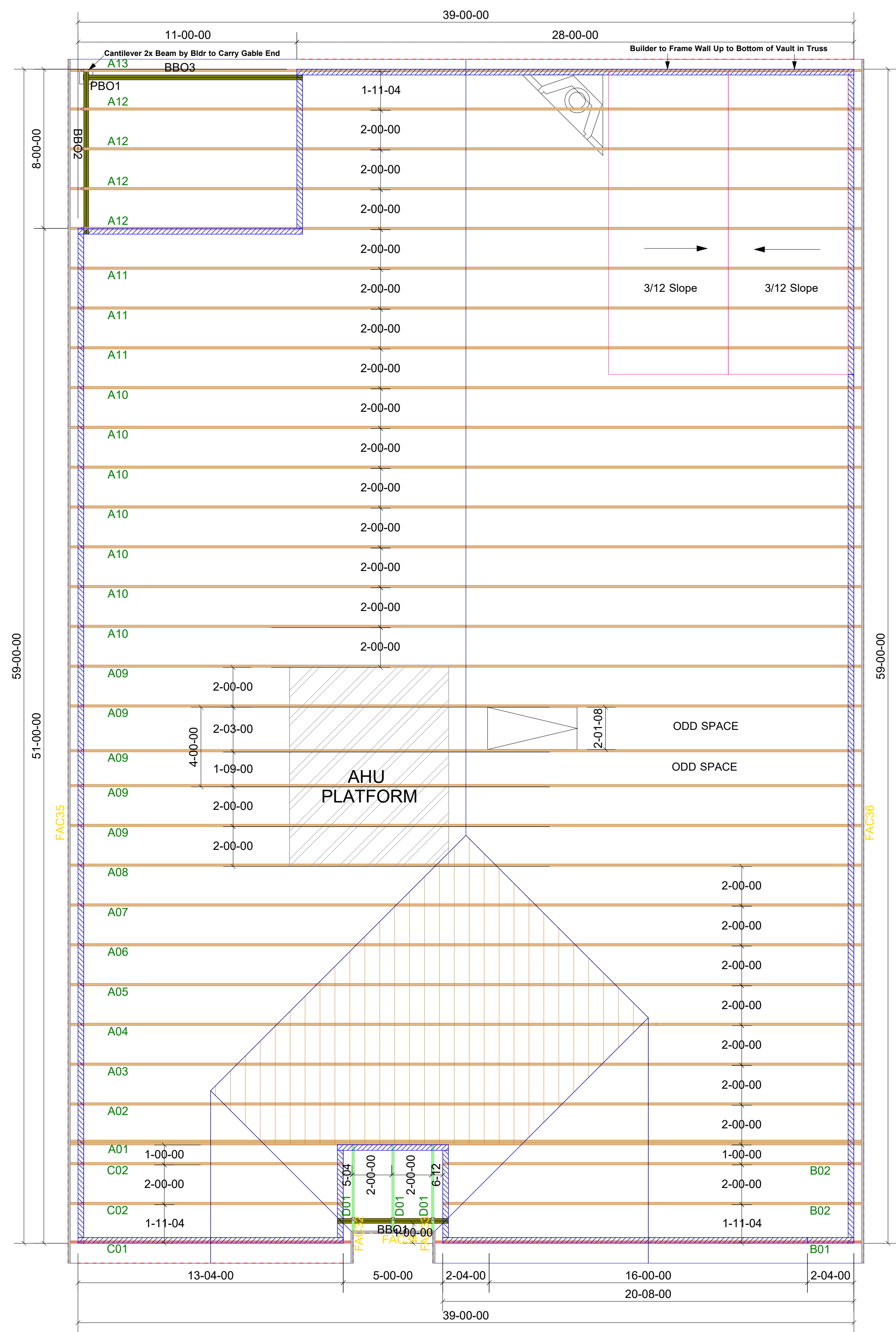

** FRAMER MUST REFER TO PLANS WHILE SETTING COMPONENTS. ** DAMAGED COMPONENTS SHOULD NOT BE INSTALLED UNLESS TOLD TO BY THE COMPONENT PLANT. ** TRUSS TO TRUSS CONNECTIONS ARE TOE-NAILED, UNLESS NOTED OTHERWISE.

** GIRDERS MUST BE FULLY CONNECTED TOGETHER PRIOR TO ADDING ANY LOADS. ** DIMENSIONS ARE READ AS: FOOT-INCH-SIXTEENTH. ** All uplift connectors shown within these documents are recommendations only. Per ANS/ITPI 1, all uplift connectors are the responsibility of the bldg designer and/or contractor.

** TRIANGULAR SYMBOL NEAR END OF TRUSS INDICATES LEFT END OF TRUSS AS SHOWN ON INDIVIDUAL TRUSS DRAWINGS.

** PLUMBING DROPS NOTED ARE IN THE APPROXIMATE LOCATIONS PER PLAN. BUILDER TO VERIFY LOCATIONS BEFORE SETTING TRUSSES.

** REFER TO FINAL TRUSS ENGINEERING SHEETS FOR PLY TO PLY CONNECTIONS.

RE: 24070189
 43 Mason Ridge-Roof-Cali M VMB GRH

Trenco
 818 Soundside Rd
 Edenton, NC 27932

Site Information:

Customer: DR Horton Inc Project Name: 24070189
 Lot/Block: 43 Model:
 Address: Subdivision: Mason Ridge
 City: Spring Lake State: NC

General Truss Engineering Criteria & Design Loads (Individual Truss Design Drawings Show Special Loading Conditions):

Design Code: IRC2018/TPI2014 Design Program: MiTek 20/20 8.7
 Wind Code: ASCE 7-16 Wind Speed: 130 mph
 Roof Load: 40.0 psf Floor Load: N/A psf

This package includes 18 individual, dated Truss Design Drawings and 0 Additional Drawings.

| No. | Seal# | Truss Name | Date |
|-----|-----------|------------|----------|
| 1 | I65976663 | A01 | 6/4/2024 |
| 2 | I65976664 | A02 | 6/4/2024 |
| 3 | I65976665 | A03 | 6/4/2024 |
| 4 | I65976666 | A04 | 6/4/2024 |
| 5 | I65976667 | A05 | 6/4/2024 |
| 6 | I65976668 | A06 | 6/4/2024 |
| 7 | I65976669 | A07 | 6/4/2024 |
| 8 | I65976670 | A08 | 6/4/2024 |
| 9 | I65976671 | A09 | 6/4/2024 |
| 10 | I65976672 | A10 | 6/4/2024 |
| 11 | I65976673 | A11 | 6/4/2024 |
| 12 | I65976674 | A12 | 6/4/2024 |
| 13 | I65976675 | A13 | 6/4/2024 |
| 14 | I65976676 | B01 | 6/4/2024 |
| 15 | I65976677 | B02 | 6/4/2024 |
| 16 | I65976678 | C01 | 6/4/2024 |
| 17 | I65976679 | C02 | 6/4/2024 |
| 18 | I65976680 | D01 | 6/4/2024 |

The truss drawing(s) referenced above have been prepared by Truss Engineering Co. under my direct supervision based on the parameters provided by Carter Components (Sanford, NC)).

Truss Design Engineer's Name: Gilbert, Eric

My license renewal date for the state of North Carolina is December 31, 2024.

North Carolina COA: C-0844

IMPORTANT NOTE: The seal on these truss component designs is a certification that the engineer named is licensed in the jurisdiction(s) identified and that the designs comply with ANSI/TPI 1. These designs are based upon parameters shown (e.g., loads, supports, dimensions, shapes and design codes), which were given to TRENCO. Any project specific information included is for TRENCO customers file reference purpose only, and was not taken into account in the preparation of these designs. TRENCO has not independently verified the applicability of the design parameters or the designs for any particular building. Before use, the building designer should verify applicability of design parameters and properly incorporate these designs into the overall building design per ANSI/TPI 1, Chapter 2.

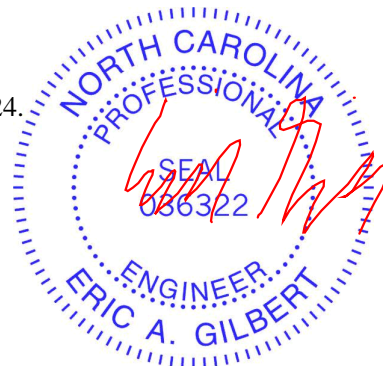

June 04, 2024

| | | | | | | |
|-----------------|--------------|----------------------------|----------|----------|--|-----------|
| Job 24070189 | Truss A01 | Truss Type Roof Special | Qty 1 | Ply 2 | 43 Mason Ridge-Roof-Cali M VMB GRH Job Reference (optional) | 165976663 |
|-----------------|--------------|----------------------------|----------|----------|--|-----------|

Carter Components (Sanford, NC), Sanford, NC - 27332,

Run: 8.73 S Apr 25 2024 Print: 8.730 S Apr 25 2024 MiTek Industries, Inc. Mon Jun 03 09:40:51
ID: Evh8gst48bcRWOT7Y3HWizwjCh-RfC?PsB70Hq3NSgPqnL8w3ulTXbGKWCRDoi7J4zJC?f

Page: 1

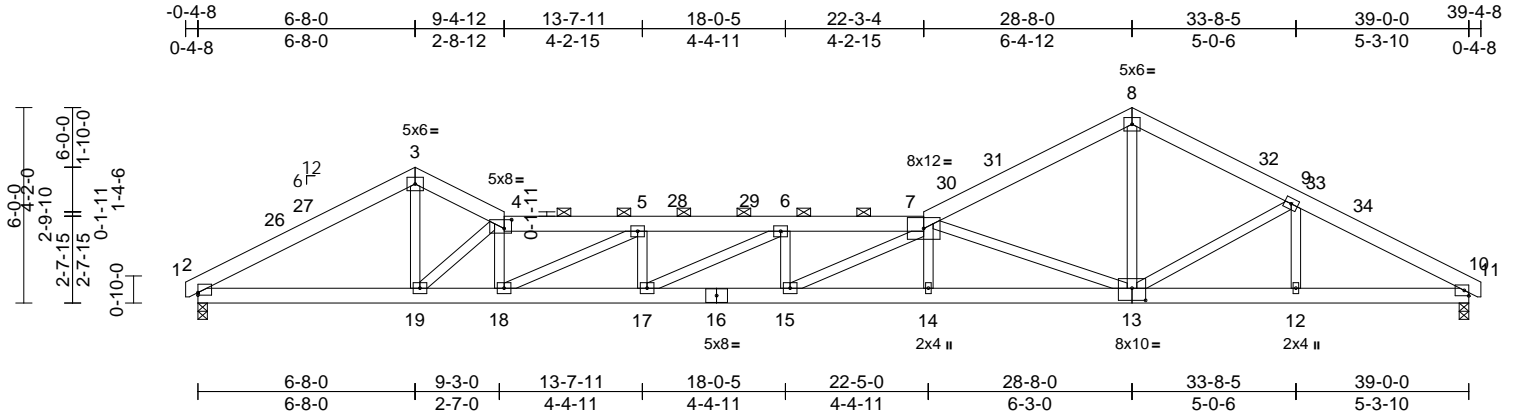

Scale = 1:70.7

Plate Offsets (X, Y): [2:Edge,0-0-15], [4:0-2-12,0-3-4], [13:0-5-0,0-4-8]

| Loading | (psf) | Spacing | 2-0-0 | CSI | DEFL | in | (loc) | l/defl | L/d | PLATES | GRIP |
|-------------|-------|-----------------|-----------------|------------|----------|-------|-------|--------|-----|----------------|----------|
| TCLL (roof) | 20.0 | Plate Grip DOL | 1.15 | TC | Vert(LL) | -0.31 | 14-15 | >999 | 240 | MT20 | 244/190 |
| Snow (Pf) | 20.0 | Lumber DOL | 1.15 | BC | Vert(CT) | -0.60 | 14-15 | >780 | 180 | | |
| TCDL | 10.0 | Rep Stress Incr | YES | WB | Horz(CT) | 0.08 | 10 | n/a | n/a | | |
| BCLL | 0.0* | Code | IRC2018/TPI2014 | Matrix-MSH | | | | | | | |
| BCDL | 10.0 | | | | | | | | | | |
| | | | | | | | | | | Weight: 525 lb | FT = 20% |

LUMBER

TOP CHORD 2x6 SP No.2
BOT CHORD 2x6 SP No.2
WEBS 2x4 SP No.3

BRACING

TOP CHORD Structural wood sheathing directly applied or 6-0-0 oc purlins, except 2-0-0 oc purlins (5-9-9 max.): 4-7.
BOT CHORD Rigid ceiling directly applied or 10-0-0 oc bracing.

REACTIONS

(size) 2=0-3-8, 10=0-3-8
Max Horiz 2=84 (LC 18)
Max Uplift 2=-226 (LC 14), 10=-113 (LC 14)
Max Grav 2=1610 (LC 46), 10=1647 (LC 50)

FORCES

(lb) - Maximum Compression/Maximum Tension
TOP CHORD 1-2=0/16, 2-3=-2768/396, 3-4=-2698/414, 4-5=-4946/692, 5-6=-6480/858, 6-7=-7014/895, 7-8=-2629/360, 8-9=-2585/370, 9-10=-2833/351, 10-11=0/9
BOT CHORD 2-19=-351/2376, 18-19=-706/4996, 17-18=-869/6480, 15-17=-905/7013, 14-15=-816/6768, 12-14=-811/6767, 10-12=-243/2443
WEBS 4-18=-46/872, 7-14=-9/138, 8-13=-152/1858, 9-13=-364/142, 7-13=-4778/654, 9-12=-79/74, 7-15=-133/718, 5-17=0/399, 5-18=-1749/186, 6-17=-707/71, 6-15=-205/154, 3-19=-241/2230, 4-19=-3497/460

NOTES

- 2-ply truss to be connected together with 10d (0.131"x3") nails as follows:
Top chords connected as follows: 2x6 - 2 rows staggered at 0-9-0 oc.
Bottom chords connected as follows: 2x6 - 2 rows staggered at 0-9-0 oc.
Web connected as follows: 2x4 - 1 row at 0-9-0 oc.
- All loads are considered equally applied to all plies, except if noted as front (F) or back (B) face in the LOAD CASE(S) section. Ply to ply connections have been provided to distribute only loads noted as (F) or (B), unless otherwise indicated.
- Unbalanced roof live loads have been considered for this design.
- Wind: ASCE 7-16; Vult=130mph (3-second gust) Vasd=103mph; TC DL=6.0psf; BCDL=6.0psf; h=25ft; Cat. II; Exp B; Enclosed; MWFRS (envelope) exterior zone and C-C Exterior(2E) -0-3-14 to 3-6-14, Exterior(2R) 3-6-14 to 6-8-0, Exterior(2E) 6-8-0 to 9-4-12, Interior (1) 9-4-12 to 24-9-5, Exterior(2R) 24-9-5 to 32-6-11, Interior (1) 32-6-11 to 35-5-2, Exterior(2E) 35-5-2 to 39-3-13 zone; cantilever left and right exposed; end vertical left and right exposed; C-C for members and forces & MWFRS for reactions shown; Lumber DOL=1.60 plate grip DOL=1.60
- TCLL: ASCE 7-16; Pr=20.0 psf (roof LL: Lum DOL=1.15 Plate DOL=1.15); Pf=20.0 psf (Lum DOL=1.15 Plate DOL=1.15); Is=1.0; Rough Cat B; Fully Exp.; Ce=0.9; Cs=1.00; Ct=1.10
- Unbalanced snow loads have been considered for this design.
- This truss has been designed for greater of min roof live load of 12.0 psf or 1.00 times flat roof load of 20.0 psf on overhangs non-concurrent with other live loads.
- Provide adequate drainage to prevent water ponding.
- All plates are 4x5 MT20 unless otherwise indicated.
- This truss has been designed for a 10.0 psf bottom chord live load nonconcurrent with any other live loads.

- * This truss has been designed for a live load of 20.0psf on the bottom chord in all areas where a rectangle 3-06-00 tall by 2-00-00 wide will fit between the bottom chord and any other members.
- One H2.5A Simpson Strong-Tie connectors recommended to connect truss to bearing walls due to UPLIFT at jt(s) 2 and 10. This connection is for uplift only and does not consider lateral forces.
- This truss is designed in accordance with the 2018 International Residential Code sections R502.11.1 and R802.10.2 and referenced standard ANSI/TPI 1.
- Graphical purlin representation does not depict the size or the orientation of the purlin along the top and/or bottom chord.

LOAD CASE(S) Standard

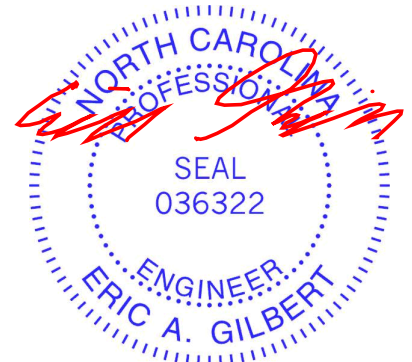

June 4, 2024

WARNING - Verify design parameters and READ NOTES ON THIS AND INCLUDED MITEK REFERENCE PAGE MII-7473 rev. 1/2/2023 BEFORE USE.

Design valid for use only with MiTek® connectors. This design is based only upon parameters shown, and is for an individual building component, not a truss system. Before use, the building designer must verify the applicability of design parameters and properly incorporate this design into the overall building design. Bracing indicated is to prevent buckling of individual truss web and/or chord members only. Additional temporary and permanent bracing is always required for stability and to prevent collapse with possible personal injury and property damage. For general guidance regarding the fabrication, storage, delivery, erection and bracing of trusses and truss systems, see **ANSI/TPI Quality Criteria and DSB-22** available from Truss Plate Institute (www.tpinst.org) and **BCSI Building Component Safety Information** available from the Structural Building Component Association (www.sbcacomponents.com)



818 Soundside Road
Edenton, NC 27932

| | | | | | | |
|-----------------|--------------|----------------------------|----------|----------|--|-----------|
| Job 24070189 | Truss A02 | Truss Type Roof Special | Qty 1 | Ply 1 | 43 Mason Ridge-Roof-Cali M VMB GRH Job Reference (optional) | 165976664 |
|-----------------|--------------|----------------------------|----------|----------|--|-----------|

Carter Components (Sanford, NC), Sanford, NC - 27332,

Run: 8.73 S Apr 25 2024 Print: 8.730 S Apr 25 2024 MiTek Industries, Inc. Mon Jun 03 09:40:52
ID:Evh8gst48bcRWOT7Y3HWizwjCh-RfC?PsB70Hq3NSgPqnL8w3ulTXbGKWRCDoi7J4zJC?f

Page: 1

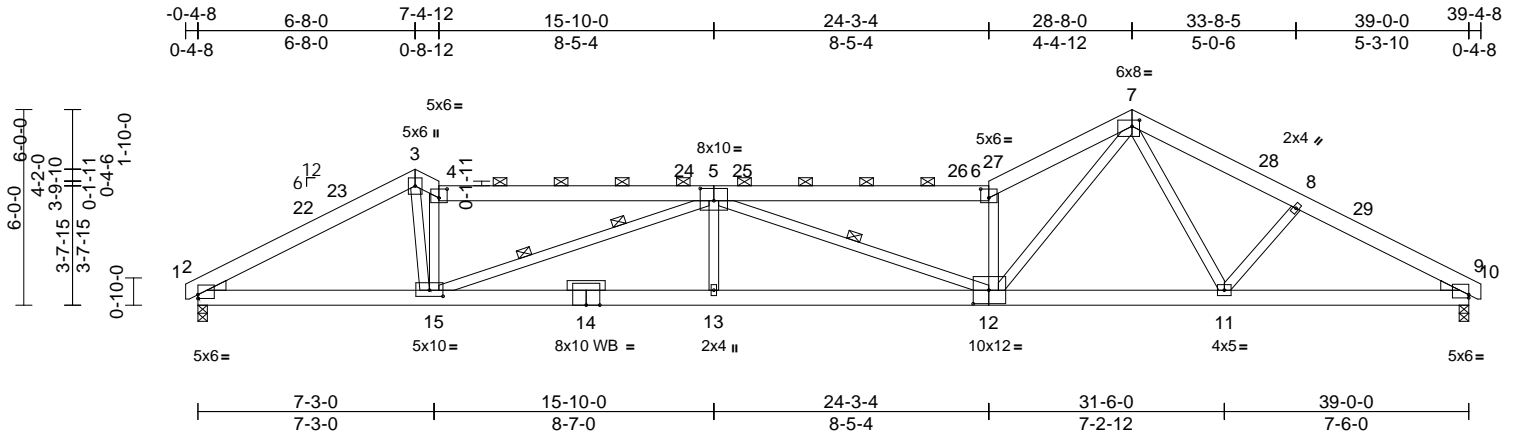

Scale = 1:70.7

Plate Offsets (X, Y): [2:Edge,0-1-7], [4:0-3-0,0-3-4], [5:0-5-0,0-4-8], [6:0-3-0,0-3-4], [7:0-2-12,0-2-4], [9:Edge,0-1-3], [12:0-5-12,0-5-0], [15:0-5-0,0-2-4]

| Loading | (psf) | Spacing | 2-0-0 | CSI | DEFL | in | (loc) | l/defl | L/d | PLATES | GRIP | |
|-------------|-------|-----------------|-----------------|------------|------|----------|-------|--------|------|--------|----------------|----------|
| TCLL (roof) | 20.0 | Plate Grip DOL | 1.15 | TC | 0.88 | Vert(LL) | -0.39 | 12-13 | >999 | 240 | MT20 | 244/190 |
| Snow (Pf) | 20.0 | Lumber DOL | 1.15 | BC | 0.71 | Vert(CT) | -0.73 | 12-13 | >645 | 180 | | |
| TCDL | 10.0 | Rep Stress Incr | YES | WB | 0.99 | Horz(CT) | 0.10 | 9 | n/a | n/a | | |
| BCLL | 0.0* | Code | IRC2018/TPI2014 | Matrix-MSH | | | | | | | | |
| BCDL | 10.0 | | | | | | | | | | | |
| | | | | | | | | | | | Weight: 263 lb | FT = 20% |

LUMBER
TOP CHORD 2x6 SP No.2
BOT CHORD 2x6 SP 2400F 2.0E *Except* 12-9:2x6 SP No.2
WEBS 2x4 SP No.3 *Except* 15-3,12-7:2x4 SP No.2
OTHERS 2x4 SP No.3
WEDGE Left: 2x4 SP No.3
Right: 2x4 SP No.3

BRACING
TOP CHORD Structural wood sheathing directly applied or 3-0-6 oc purlins, except 2-0-0 oc purlins (2-2-0 max.): 4-6.
BOT CHORD Rigid ceiling directly applied or 10-0-0 oc bracing.
WEBS 1 Row at midpt 5-12
WEBS 2 Rows at 1/3 pts 5-15

REACTIONS (size) 2=0-3-8, 9=0-3-8
Max Horiz 2=84 (LC 18)
Max Uplift 2=-226 (LC 14), 9=-113 (LC 14)
Max Grav 2=1604 (LC 21), 9=1670 (LC 50)

FORCES (lb) - Maximum Compression/Maximum Tension
TOP CHORD 1-2=0/16, 2-3=-2926/397, 3-4=-3533/492, 4-6=-4630/540, 6-7=-5247/669, 7-8=-2745/373, 8-9=-2948/373, 9-10=0/9
BOT CHORD 2-15=-353/2562, 13-15=-650/5354, 11-13=-650/5354, 9-11=-262/2539
WEBS 3-15=-315/3036, 4-15=-2101/318, 5-15=-2372/249, 5-13=0/362, 5-12=-776/159, 6-12=-2766/442, 7-12=-512/4025, 7-11=-50/427, 8-11=-350/169

NOTES
1) Unbalanced roof live loads have been considered for this design.

- Wind: ASCE 7-16; Vult=130mph (3-second gust) Vasd=103mph; TCDL=6.0psf; BCDL=6.0psf; h=25ft; Cat. II; Exp B; Enclosed; MWFRS (envelope) exterior zone and C-C Exterior(2E) -0-3-14 to 3-6-14, Exterior(2R) 3-6-14 to 6-8-0, Exterior(2E) 6-8-0 to 7-4-12, Interior (1) 7-4-12 to 24-9-5, Exterior(2R) 24-9-5 to 32-6-11, Interior (1) 32-6-11 to 35-5-2, Exterior(2E) 35-5-2 to 39-3-13 zone; cantilever left and right exposed; end vertical left and right exposed; C-C for members and forces & MWFRS for reactions shown; Lumber DOL=1.60 plate grip DOL=1.60
- TCLL: ASCE 7-16; Pr=20.0 psf (roof LL: Lum DOL=1.15 Plate DOL=1.15); Pf=20.0 psf (Lum DOL=1.15 Plate DOL=1.15); Is=1.0; Rough Cat B; Fully Exp.; Ce=0.9; Cs=1.00; Ct=1.10
- Unbalanced snow loads have been considered for this design.
- This truss has been designed for greater of min roof live load of 12.0 psf or 1.00 times flat roof load of 20.0 psf on overhangs non-concurrent with other live loads.
- Provide adequate drainage to prevent water ponding.
- This truss has been designed for a 10.0 psf bottom chord live load nonconcurrent with any other live loads.
- * This truss has been designed for a live load of 20.0psf on the bottom chord in all areas where a rectangle 3-06-00 tall by 2-00-00 wide will fit between the bottom chord and any other members.
- One H2.5A Simpson Strong-Tie connectors recommended to connect truss to bearing walls due to UPLIFT at jt(s) 2 and 9. This connection is for uplift only and does not consider lateral forces.
- This truss is designed in accordance with the 2018 International Residential Code sections R502.11.1 and R802.10.2 and referenced standard ANSI/TPI 1.
- Graphical purlin representation does not depict the size or the orientation of the purlin along the top and/or bottom chord.

LOAD CASE(S) Standard



June 4, 2024

WARNING - Verify design parameters and READ NOTES ON THIS AND INCLUDED MITEK REFERENCE PAGE MII-7473 rev. 1/2/2023 BEFORE USE.

Design valid for use only with MiTek® connectors. This design is based only upon parameters shown, and is for an individual building component, not a truss system. Before use, the building designer must verify the applicability of design parameters and properly incorporate this design into the overall building design. Bracing indicated is to prevent buckling of individual truss web and/or chord members only. Additional temporary and permanent bracing is always required for stability and to prevent collapse with possible personal injury and property damage. For general guidance regarding the fabrication, storage, delivery, erection and bracing of trusses and truss systems, see **ANSI/TPI Quality Criteria and DSB-22** available from Truss Plate Institute (www.tpinst.org) and **BCSI Building Component Safety Information** available from the Structural Building Component Association (www.sbcacomponents.com)



818 Soundside Road
Edenton, NC 27932

| | | | | | | |
|-----------------|--------------|----------------------------|----------|----------|--|-----------|
| Job 24070189 | Truss A03 | Truss Type Roof Special | Qty 1 | Ply 1 | 43 Mason Ridge-Roof-Cali M VMB GRH Job Reference (optional) | 165976665 |
|-----------------|--------------|----------------------------|----------|----------|--|-----------|

Carter Components (Sanford, NC), Sanford, NC - 27332,

Run: 8.73 S Apr 25 2024 Print: 8.730 S Apr 25 2024 MiTek Industries, Inc. Mon Jun 03 09:40:52
ID: Evh8gst48bcRWOT7Y3HWizWjCh-RfC?PsB70Hq3NSgPqnL8w3ulTXbGKWRCDoi7J4zJC?f

Page: 1

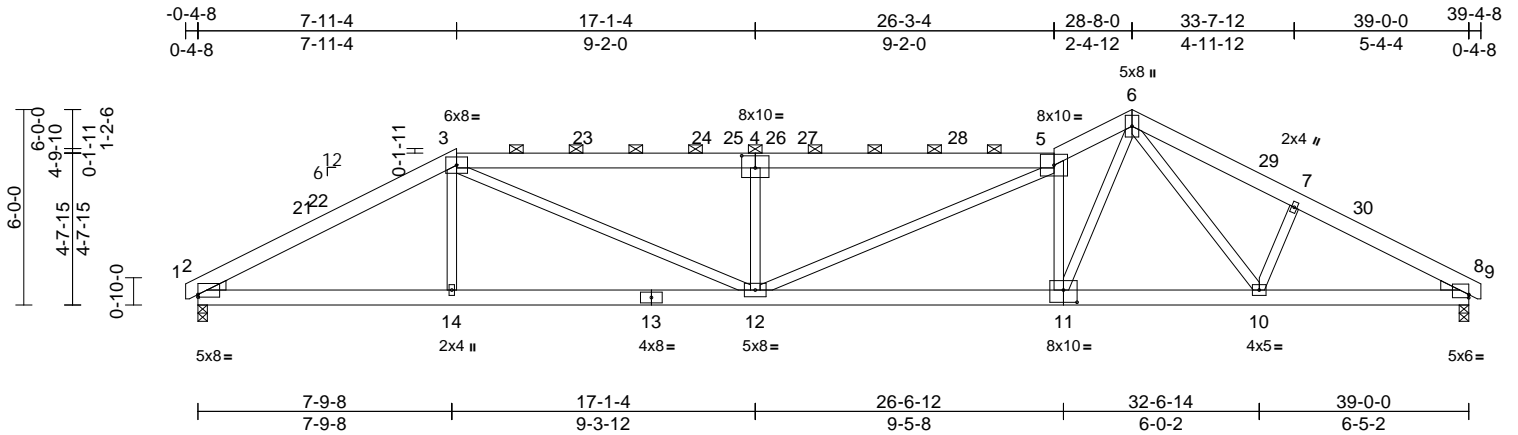

Scale = 1:70.7

Plate Offsets (X, Y): [2:Edge,0-0-15], [4:0-5-0,0-4-8], [8:Edge,0-1-3], [11:0-5-0,0-4-8]

| Loading | (psf) | Spacing | 2-0-0 | CSI | DEFL | in | (loc) | l/defl | L/d | PLATES | GRIP | |
|-------------|-------|-----------------|-----------------|------------|------|----------|-------|--------|------|--------|----------------|----------|
| TCLL (roof) | 20.0 | Plate Grip DOL | 1.15 | TC | 0.96 | Vert(LL) | -0.29 | 12 | >999 | 240 | MT20 | 244/190 |
| Snow (Pf) | 20.0 | Lumber DOL | 1.15 | BC | 0.82 | Vert(CT) | -0.52 | 11-12 | >893 | 180 | | |
| TCDL | 10.0 | Rep Stress Incr | YES | WB | 0.93 | Horz(CT) | 0.10 | 8 | n/a | n/a | | |
| BCLL | 0.0* | Code | IRC2018/TPI2014 | Matrix-MSH | | | | | | | | |
| BCDL | 10.0 | | | | | | | | | | | |
| | | | | | | | | | | | Weight: 261 lb | FT = 20% |

LUMBER
TOP CHORD 2x6 SP No.2
BOT CHORD 2x6 SP No.2
WEBS 2x4 SP No.3 *Except* 11-6:2x4 SP No.2
WEDGE Left: 2x4 SP No.3
Right: 2x4 SP No.3

BRACING
TOP CHORD Structural wood sheathing directly applied or 3-8-0 oc purlins, except 2-0-0 oc purlins (2-2-0 max.): 3-5.
BOT CHORD Rigid ceiling directly applied or 10-0-0 oc bracing.

REACTIONS (size) 2=0-3-8, 8=0-3-8
Max Horiz 2=84 (LC 18)
Max Uplift 2=-226 (LC 14), 8=-113 (LC 14)
Max Grav 2=1604 (LC 21), 8=1642 (LC 46)

FORCES (lb) - Maximum Compression/Maximum Tension
TOP CHORD 1-2=0/13, 2-3=-2959/392, 3-5=-4234/552, 5-6=-3694/499, 6-7=-2733/405, 7-8=-2863/366, 8-9=0/9
BOT CHORD 2-14=-336/2594, 12-14=-339/2591, 10-12=-343/3411, 8-10=-256/2465
WEBS 3-14=0/309, 3-12=-226/1809, 4-12=-944/268, 5-12=-161/905, 5-11=-2478/420, 6-11=-351/2842, 6-10=-111/435, 7-10=-349/167

- Wind: ASCE 7-16; Vult=130mph (3-second gust) Vasd=103mph; TCDL=6.0psf; BCDL=6.0psf; h=25ft; Cat. II; Exp B; Enclosed; MWFRS (envelope) exterior zone and C-C Exterior(2E) -0-3-14 to 3-6-14, Interior (1) 3-6-14 to 4-0-9, Exterior(2R) 4-0-9 to 11-9-15, Interior (1) 11-9-15 to 26-3-4, Exterior(2R) 26-3-4 to 32-6-11, Interior (1) 32-6-11 to 35-5-2, Exterior(2E) 35-5-2 to 39-3-13 zone; cantilever left and right exposed ; end vertical left and right exposed;C-C for members and forces & MWFRS for reactions shown; Lumber DOL=1.60 plate grip DOL=1.60
- TCLL: ASCE 7-16; Pr=20.0 psf (roof LL: Lum DOL=1.15 Plate DOL=1.15); Pf=20.0 psf (Lum DOL=1.15 Plate DOL=1.15); Is=1.0; Rough Cat B; Fully Exp.; Ce=0.9; Cs=1.00; Ct=1.10
- Unbalanced snow loads have been considered for this design.
- This truss has been designed for greater of min roof live load of 12.0 psf or 1.00 times flat roof load of 20.0 psf on overhangs non-concurrent with other live loads.
- Provide adequate drainage to prevent water ponding.
- This truss has been designed for a 10.0 psf bottom chord live load nonconcurrent with any other live loads.
- * This truss has been designed for a live load of 20.0psf on the bottom chord in all areas where a rectangle 3-06-00 tall by 2-00-00 wide will fit between the bottom chord and any other members.
- One H2.5A Simpson Strong-Tie connectors recommended to connect truss to bearing walls due to UPLIFT at jt(s) 2 and 8. This connection is for uplift only and does not consider lateral forces.
- This truss is designed in accordance with the 2018 International Residential Code sections R502.11.1 and R802.10.2 and referenced standard ANSI/TPI 1.
- Graphical purlin representation does not depict the size or the orientation of the purlin along the top and/or bottom chord.

LOAD CASE(S) Standard



June 4, 2024

WARNING - Verify design parameters and READ NOTES ON THIS AND INCLUDED MITEK REFERENCE PAGE MII-7473 rev. 1/2/2023 BEFORE USE.

Design valid for use only with MiTek® connectors. This design is based only upon parameters shown, and is for an individual building component, not a truss system. Before use, the building designer must verify the applicability of design parameters and properly incorporate this design into the overall building design. Bracing indicated is to prevent buckling of individual truss web and/or chord members only. Additional temporary and permanent bracing is always required for stability and to prevent collapse with possible personal injury and property damage. For general guidance regarding the fabrication, storage, delivery, erection and bracing of trusses and truss systems, see **ANSI/TPI Quality Criteria and DSB-22** available from Truss Plate Institute (www.tpinst.org) and **BCSI Building Component Safety Information** available from the Structural Building Component Association (www.sbcacomponents.com)



818 Soundside Road
Edenton, NC 27932

| | | | | | | |
|-----------------|--------------|-------------------|----------|----------|--|-----------|
| Job 24070189 | Truss A04 | Truss Type Hip | Qty 1 | Ply 1 | 43 Mason Ridge-Roof-Cali M VMB GRH Job Reference (optional) | 165976666 |
|-----------------|--------------|-------------------|----------|----------|--|-----------|

Carter Components (Sanford, NC), Sanford, NC - 27332,

Run: 8.73 S Apr 25 2024 Print: 8.730 S Apr 25 2024 MiTek Industries, Inc. Mon Jun 03 09:40:52
ID: Evh8gst48bcCRWOT7Y3HWIzWjCh-RfC?PsB70Hq3NSgPqnL8w3ulTXbGKWrCDoi7J4zJC?f

Page: 1

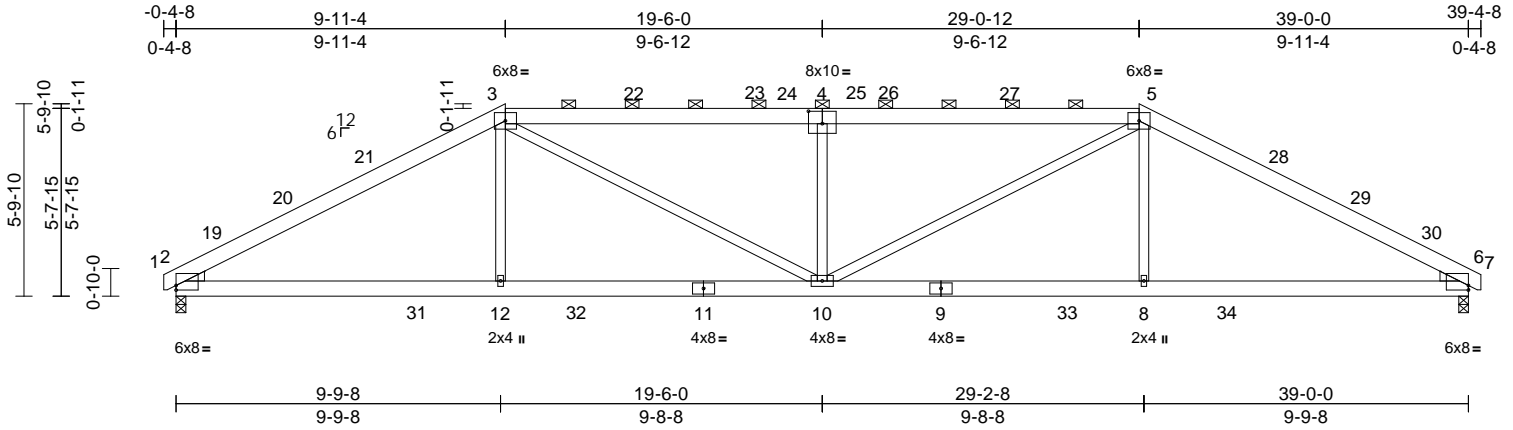

Scale = 1:69.5

Plate Offsets (X, Y): [2:Edge,0-1-11], [4:0-5-0,0-4-8], [6:Edge,0-1-11]

| Loading | (psf) | Spacing | 2-0-0 | CSI | DEFL | in | (loc) | l/defl | L/d | PLATES | GRIP | |
|-------------|-------|-----------------|-----------------|------------|------|----------|-------|--------|------|--------|----------------|----------|
| TCLL (roof) | 20.0 | Plate Grip DOL | 1.15 | TC | 0.93 | Vert(LL) | -0.25 | 10-12 | >999 | 240 | MT20 | 244/190 |
| Snow (Pf) | 20.0 | Lumber DOL | 1.15 | BC | 0.87 | Vert(CT) | -0.41 | 10-12 | >999 | 180 | | |
| TCDL | 10.0 | Rep Stress Incr | YES | WB | 0.49 | Horz(CT) | 0.11 | 6 | n/a | n/a | | |
| BCLL | 0.0* | Code | IRC2018/TPI2014 | Matrix-MSH | | | | | | | | |
| BCDL | 10.0 | | | | | | | | | | | |
| | | | | | | | | | | | Weight: 245 lb | FT = 20% |

LUMBER

TOP CHORD 2x6 SP No.2
 BOT CHORD 2x6 SP No.2
 WEBS 2x4 SP No.3 *Except* 10-3,10-5:2x4 SP No.2
 WEDGE Left: 2x4 SP No.3
 Right: 2x4 SP No.3

BRACING

TOP CHORD Structural wood sheathing directly applied or
 2-2-0 oc purlins, except
 2-0-0 oc purlins (2-2-0 max.): 3-5.
 BOT CHORD Rigid ceiling directly applied or 10-0-0 oc
 bracing.

REACTIONS

(size) 2=0-3-8, 6=0-3-8
 Max Horiz 2=80 (LC 18)
 Max Uplift 2=-89 (LC 11), 6=-89 (LC 10)
 Max Grav 2=1769 (LC 5), 6=1769 (LC 6)

FORCES

(lb) - Maximum Compression/Maximum
 Tension
 TOP CHORD 1-2=0/9, 2-3=-3067/377, 3-5=-3714/462,
 5-6=-3067/377, 6-7=0/9
 BOT CHORD 2-12=-216/2686, 10-12=-219/2676,
 8-10=-219/2676, 6-8=-216/2686
 WEBS 3-12=0/465, 3-10=-214/1211, 4-10=-955/278,
 5-10=-214/1211, 5-8=0/465

NOTES

1) Unbalanced roof live loads have been considered for
 this design.

- Wind: ASCE 7-16; Vult=130mph (3-second gust)
 Vasd=103mph; TCDL=6.0psf; BCDL=6.0psf; h=25ft; Cat.
 II; Exp B; Enclosed; MWFRS (envelope) exterior zone
 and C-C Exterior(2E) -0-3-14 to 3-6-14, Interior (1)
 3-6-14 to 6-0-9, Exterior(2R) 6-0-9 to 13-9-15, Interior
 (1) 13-9-15 to 25-2-1, Exterior(2R) 25-2-1 to 32-11-7,
 Interior (1) 32-11-7 to 35-5-2, Exterior(2E) 35-5-2 to
 39-3-13 zone; cantilever left and right exposed ; end
 vertical left and right exposed;C-C for members and
 forces & MWFRS for reactions shown; Lumber
 DOL=1.60 plate grip DOL=1.60
- TCLL: ASCE 7-16; Pr=20.0 psf (roof LL: Lum DOL=1.15
 Plate DOL=1.15); Pf=20.0 psf (Lum DOL=1.15 Plate
 DOL=1.15); Is=1.0; Rough Cat B; Fully Exp.; Ce=0.9;
 Cs=1.00; Ct=1.10
- Unbalanced snow loads have been considered for this
 design.
- This truss has been designed for greater of min roof live
 load of 12.0 psf or 1.00 times flat roof load of 20.0 psf on
 overhangs non-concurrent with other live loads.
- Provide adequate drainage to prevent water ponding.
- This truss has been designed for a 10.0 psf bottom
 chord live load nonconcurrent with any other live loads.
- * This truss has been designed for a live load of 20.0psf
 on the bottom chord in all areas where a rectangle
 3-06-00 tall by 2-00-00 wide will fit between the bottom
 chord and any other members, with BCDL = 10.0psf.
- One H2.5A Simpson Strong-Tie connectors
 recommended to connect truss to bearing walls due to
 UPLIFT at jt(s) 2 and 6. This connection is for uplift only
 and does not consider lateral forces.
- This truss is designed in accordance with the 2018
 International Residential Code sections R502.11.1 and
 R802.10.2 and referenced standard ANSI/TPI 1.
- Graphical purlin representation does not depict the size
 or the orientation of the purlin along the top and/or
 bottom chord.

LOAD CASE(S) Standard



June 4, 2024

WARNING - Verify design parameters and READ NOTES ON THIS AND INCLUDED MITEK REFERENCE PAGE MII-7473 rev. 1/2/2023 BEFORE USE.

Design valid for use only with MiTek® connectors. This design is based only upon parameters shown, and is for an individual building component, not a truss system. Before use, the building designer must verify the applicability of design parameters and properly incorporate this design into the overall building design. Bracing indicated is to prevent buckling of individual truss web and/or chord members only. Additional temporary and permanent bracing is always required for stability and to prevent collapse with possible personal injury and property damage. For general guidance regarding the fabrication, storage, delivery, erection and bracing of trusses and truss systems, see **ANSI/TPI Quality Criteria and DSB-22** available from Truss Plate Institute (www.tpinst.org) and **BCSI Building Component Safety Information** available from the Structural Building Component Association (www.sbcacomponents.com)



818 Soundside Road
 Edenton, NC 27932

| | | | | | | |
|-----------------|--------------|-------------------|----------|----------|--|-----------|
| Job 24070189 | Truss A05 | Truss Type Hip | Qty 1 | Ply 1 | 43 Mason Ridge-Roof-Cali M VMB GRH Job Reference (optional) | 165976667 |
|-----------------|--------------|-------------------|----------|----------|--|-----------|

Carter Components (Sanford, NC), Sanford, NC - 27332,

Run: 8.73 S Apr 25 2024 Print: 8.730 S Apr 25 2024 MiTek Industries, Inc. Mon Jun 03 09:40:52
ID:Evh8gst48bcRWOT7Y3HWizWjCh-RfC?PsB70Hq3NSgPqnL8w3ulTXbGKwRCDoi7J4zJC?f

Page: 1

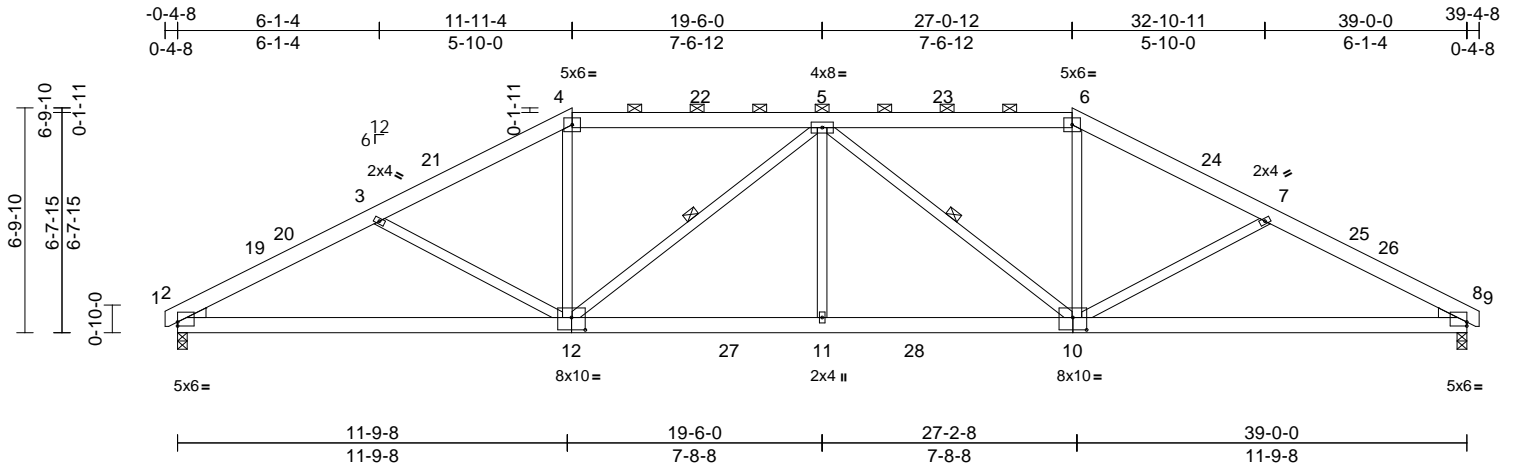

Scale = 1:69.7

Plate Offsets (X, Y): [2:Edge,0-1-7], [8:Edge,0-1-7], [10:0-5-0,0-4-8], [12:0-5-0,0-4-8]

| Loading | (psf) | Spacing | 2-0-0 | CSI | DEFL | in | (loc) | l/defl | L/d | PLATES | GRIP | |
|-------------|-------|-----------------|-----------------|------------|------|----------|-------|--------|------|--------|----------------|----------|
| TCLL (roof) | 20.0 | Plate Grip DOL | 1.15 | TC | 0.51 | Vert(LL) | -0.16 | 11-12 | >999 | 240 | MT20 | 244/190 |
| Snow (Pf) | 20.0 | Lumber DOL | 1.15 | BC | 0.87 | Vert(CT) | -0.29 | 11-12 | >999 | 180 | | |
| TCDL | 10.0 | Rep Stress Incr | YES | WB | 0.42 | Horz(CT) | 0.10 | 8 | n/a | n/a | | |
| BCLL | 0.0* | Code | IRC2018/TPI2014 | Matrix-MSH | | | | | | | | |
| BCDL | 10.0 | | | | | | | | | | | |
| | | | | | | | | | | | Weight: 266 lb | FT = 20% |

LUMBER

TOP CHORD 2x6 SP No.2
 BOT CHORD 2x6 SP No.2
 WEBS 2x4 SP No.3
 WEDGE Left: 2x4 SP No.3
 Right: 2x4 SP No.3

BRACING

TOP CHORD Structural wood sheathing directly applied or 4-0-6 oc purlins, except 2-0-0 oc purlins (4-4-1 max.): 4-6.
 BOT CHORD Rigid ceiling directly applied or 10-0-0 oc bracing.
 WEBS 1 Row at midpt 5-12, 5-10

REACTIONS

(size) 2=0-3-8, 8=0-3-8
 Max Horiz 2=96 (LC 18)
 Max Uplift 2=-97 (LC 14), 8=-97 (LC 15)
 Max Grav 2=1735 (LC 45), 8=1735 (LC 45)

FORCES

(lb) - Maximum Compression/Maximum Tension
 TOP CHORD 1-2=0/9, 2-3=-2959/437, 3-4=-2701/384, 4-5=-2410/389, 5-6=-2410/389, 6-7=-2701/384, 7-8=-2959/437, 8-9=0/9
 BOT CHORD 2-11=-307/2974, 8-11=-307/2974
 WEBS 3-12=-503/213, 4-12=0/844, 5-12=-731/164, 5-11=0/338, 5-10=-731/163, 6-10=0/844, 7-10=-503/214

NOTES

1) Unbalanced roof live loads have been considered for this design.

- Wind: ASCE 7-16; Vult=130mph (3-second gust) Vasd=103mph; TCDL=6.0psf; BCDL=6.0psf; h=25ft; Cat. II; Exp B; Enclosed; MWFRS (envelope) exterior zone and C-C Exterior(2E) -0-3-14 to 3-6-14, Interior (1) 3-6-14 to 8-0-9, Exterior(2R) 8-0-9 to 15-9-15, Interior (1) 15-9-15 to 23-2-1, Exterior(2R) 23-2-1 to 30-11-7, Interior (1) 30-11-7 to 35-5-2, Exterior(2E) 35-5-2 to 39-3-13 zone; cantilever left and right exposed; end vertical left and right exposed; C-C for members and forces & MWFRS for reactions shown; Lumber DOL=1.60 plate grip DOL=1.60
- TCLL: ASCE 7-16; Pr=20.0 psf (roof LL: Lum DOL=1.15 Plate DOL=1.15); Pf=20.0 psf (Lum DOL=1.15 Plate DOL=1.15); Is=1.0; Rough Cat B; Fully Exp.; Ce=0.9; Cs=1.00; Ct=1.10
- Unbalanced snow loads have been considered for this design.
- This truss has been designed for greater of min roof live load of 12.0 psf or 1.00 times flat roof load of 20.0 psf on overhangs non-concurrent with other live loads.
- Provide adequate drainage to prevent water ponding.
- This truss has been designed for a 10.0 psf bottom chord live load nonconcurrent with any other live loads.
- * This truss has been designed for a live load of 20.0psf on the bottom chord in all areas where a rectangle 3-06-00 tall by 2-00-00 wide will fit between the bottom chord and any other members, with BCDL = 10.0psf.
- One H2.5A Simpson Strong-Tie connectors recommended to connect truss to bearing walls due to UPLIFT at jt(s) 2 and 8. This connection is for uplift only and does not consider lateral forces.
- This truss is designed in accordance with the 2018 International Residential Code sections R502.11.1 and R802.10.2 and referenced standard ANSI/TPI 1.
- Graphical purlin representation does not depict the size or the orientation of the purlin along the top and/or bottom chord.

LOAD CASE(S) Standard

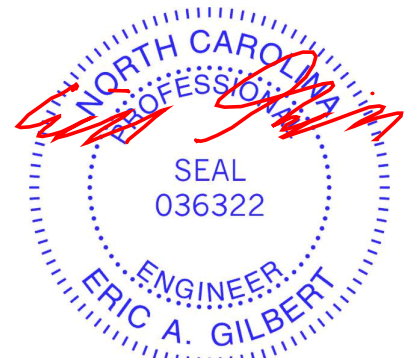

June 4, 2024

WARNING - Verify design parameters and READ NOTES ON THIS AND INCLUDED MITEK REFERENCE PAGE MII-7473 rev. 1/2/2023 BEFORE USE.

Design valid for use only with MiTek® connectors. This design is based only upon parameters shown, and is for an individual building component, not a truss system. Before use, the building designer must verify the applicability of design parameters and properly incorporate this design into the overall building design. Bracing indicated is to prevent buckling of individual truss web and/or chord members only. Additional temporary and permanent bracing is always required for stability and to prevent collapse with possible personal injury and property damage. For general guidance regarding the fabrication, storage, delivery, erection and bracing of trusses and truss systems, see **ANSI/TPI Quality Criteria and DSB-22** available from Truss Plate Institute (www.tpinst.org) and **BCSI Building Component Safety Information** available from the Structural Building Component Association (www.sbcacomponents.com)



818 Soundside Road
 Edenton, NC 27932

| | | | | | | |
|-----------------|--------------|-------------------|----------|----------|--|-----------|
| Job 24070189 | Truss A06 | Truss Type Hip | Qty 1 | Ply 1 | 43 Mason Ridge-Roof-Cali M VMB GRH Job Reference (optional) | 165976668 |
|-----------------|--------------|-------------------|----------|----------|--|-----------|

Carter Components (Sanford, NC), Sanford, NC - 27332,

Run: 8.73 S Apr 25 2024 Print: 8.730 S Apr 25 2024 MiTek Industries, Inc. Mon Jun 03 09:40:53
ID:Evh8gst48bcRWOT7Y3HWizwjCh-RfC?PsB70Hq3NSgPqnL8w3ulTXbGKWrCdoi7J4zJC?f

Page: 1

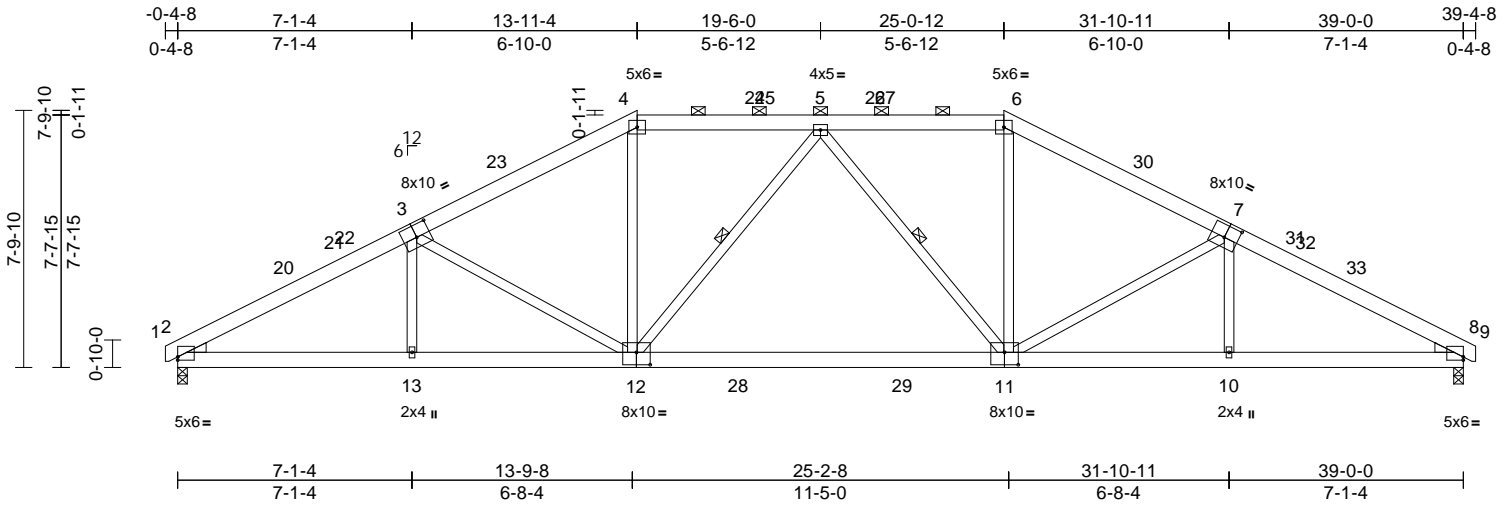

Scale = 1:69.9

Plate Offsets (X, Y): [2:Edge,0-1-3], [3:0-5-0,0-4-8], [7:0-5-0,0-4-8], [8:Edge,0-1-3], [11:0-5-0,0-4-8], [12:0-5-0,0-4-8]

| Loading | (psf) | Spacing | 2-0-0 | CSI | DEFL | in | (loc) | l/defl | L/d | PLATES | GRIP | |
|-------------|-------|-----------------|-----------------|------------|------|----------|-------|--------|------|--------|----------------|----------|
| TCLL (roof) | 20.0 | Plate Grip DOL | 1.15 | TC | 0.45 | Vert(LL) | -0.24 | 11-12 | >999 | 240 | MT20 | 244/190 |
| Snow (Pf) | 20.0 | Lumber DOL | 1.15 | BC | 0.83 | Vert(CT) | -0.42 | 11-12 | >999 | 180 | | |
| TCDL | 10.0 | Rep Stress Incr | YES | WB | 0.69 | Horz(CT) | 0.10 | 8 | n/a | n/a | | |
| BCLL | 0.0* | Code | IRC2018/TPI2014 | Matrix-MSH | | | | | | | | |
| BCDL | 10.0 | | | | | | | | | | | |
| | | | | | | | | | | | Weight: 273 lb | FT = 20% |

LUMBER

TOP CHORD 2x6 SP No.2
 BOT CHORD 2x6 SP No.2
 WEBS 2x4 SP No.3
 WEDGE Left: 2x4 SP No.3
 Right: 2x4 SP No.3

BRACING

TOP CHORD Structural wood sheathing directly applied or 3-10-3 oc purlins, except 2-0-0 oc purlins (4-9-14 max.): 4-6.
 BOT CHORD Rigid ceiling directly applied or 10-0-0 oc bracing.
 WEBS 1 Row at midpt 5-12, 5-11

REACTIONS

(size) 2=0-3-8, 8=0-3-8
 Max Horiz 2=112 (LC 14)
 Max Uplift 2=-115 (LC 14), 8=-115 (LC 15)
 Max Grav 2=1775 (LC 45), 8=1775 (LC 45)

FORCES

(lb) - Maximum Compression/Maximum Tension
 TOP CHORD 1-2=0/9, 2-4=-3071/399, 4-5=-2212/402, 5-6=-2212/402, 6-8=-3071/399, 8-9=0/9
 BOT CHORD 2-13=-269/2663, 10-13=-270/2662, 8-10=-269/2663
 WEBS 3-13=0/177, 3-12=-618/206, 4-12=-12/788, 5-12=-379/148, 5-11=-379/148, 6-11=-12/788, 7-11=-618/207, 7-10=0/177

NOTES

1) Unbalanced roof live loads have been considered for this design.

- Wind: ASCE 7-16; Vult=130mph (3-second gust) Vasd=103mph; TCDL=6.0psf; BCDL=6.0psf; h=25ft; Cat. II; Exp B; Enclosed; MWFRS (envelope) exterior zone and C-C Exterior(2E) -0-3-14 to 3-6-14, Interior (1) 3-6-14 to 10-0-9, Exterior(2R) 10-0-9 to 17-9-15, Interior (1) 17-9-15 to 21-2-1, Exterior(2R) 21-2-1 to 28-11-7, Interior (1) 28-11-7 to 35-5-2, Exterior(2E) 35-5-2 to 39-3-13 zone; cantilever left and right exposed ; end vertical left and right exposed;C-C for members and forces & MWFRS for reactions shown; Lumber DOL=1.60 plate grip DOL=1.60
- TCLL: ASCE 7-16; Pr=20.0 psf (roof LL: Lum DOL=1.15 Plate DOL=1.15); Pf=20.0 psf (Lum DOL=1.15 Plate DOL=1.15); Is=1.0; Rough Cat B; Fully Exp.; Ce=0.9; Cs=1.00; Ct=1.10
- Unbalanced snow loads have been considered for this design.
- This truss has been designed for greater of min roof live load of 12.0 psf or 1.00 times flat roof load of 20.0 psf on overhangs non-concurrent with other live loads.
- Provide adequate drainage to prevent water ponding.
- This truss has been designed for a 10.0 psf bottom chord live load nonconcurrent with any other live loads.
- * This truss has been designed for a live load of 20.0psf on the bottom chord in all areas where a rectangle 3-06-00 tall by 2-00-00 wide will fit between the bottom chord and any other members, with BCDL = 10.0psf.
- One H2.5A Simpson Strong-Tie connectors recommended to connect truss to bearing walls due to UPLIFT at jt(s) 2 and 8. This connection is for uplift only and does not consider lateral forces.
- This truss is designed in accordance with the 2018 International Residential Code sections R502.11.1 and R802.10.2 and referenced standard ANSI/TPI 1.
- Graphical purlin representation does not depict the size or the orientation of the purlin along the top and/or bottom chord.

LOAD CASE(S) Standard

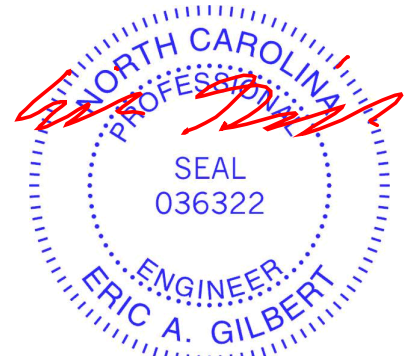

June 4, 2024

WARNING - Verify design parameters and READ NOTES ON THIS AND INCLUDED MITEK REFERENCE PAGE MII-7473 rev. 1/2/2023 BEFORE USE.

Design valid for use only with MiTek® connectors. This design is based only upon parameters shown, and is for an individual building component, not a truss system. Before use, the building designer must verify the applicability of design parameters and properly incorporate this design into the overall building design. Bracing indicated is to prevent buckling of individual truss web and/or chord members only. Additional temporary and permanent bracing is always required for stability and to prevent collapse with possible personal injury and property damage. For general guidance regarding the fabrication, storage, delivery, erection and bracing of trusses and truss systems, see **ANSI/TPI Quality Criteria and DSB-22** available from Truss Plate Institute (www.tpinst.org) and **BCSI Building Component Safety Information** available from the Structural Building Component Association (www.sbcacomponents.com)



818 Soundside Road
 Edenton, NC 27932

| | | | | | | |
|-----------------|--------------|-------------------|----------|----------|--|-----------|
| Job 24070189 | Truss A07 | Truss Type Hip | Qty 1 | Ply 1 | 43 Mason Ridge-Roof-Cali M VMB GRH Job Reference (optional) | 165976669 |
|-----------------|--------------|-------------------|----------|----------|--|-----------|

Carter Components (Sanford, NC), Sanford, NC - 27332,

Run: 8.73 S Apr 25 2024 Print: 8.730 S Apr 25 2024 MiTek Industries, Inc. Mon Jun 03 09:40:53
ID:Evh8gst48bcRWOT7Y3HWizwjCh-RfC?PsB70Hq3NSgPqnL8w3ulTxBGXWRCdoi7J4zJC?f

Page: 1

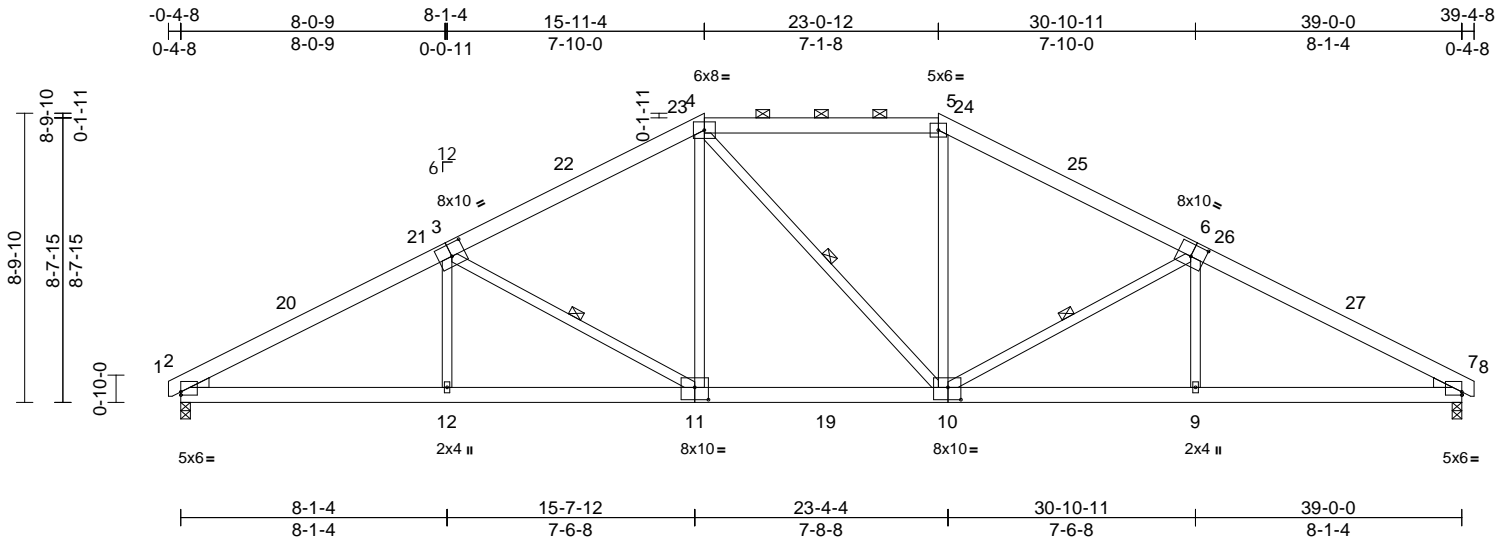

Scale = 1:70.1

Plate Offsets (X, Y): [2:Edge,0-1-3], [3:0-5-0,0-4-8], [6:0-5-0,0-4-8], [7:Edge,0-1-3], [10:0-4-12,0-4-8], [11:0-5-0,0-4-8]

| Loading | (psf) | Spacing | 2-0-0 | CSI | DEFL | in | (loc) | l/defl | L/d | PLATES | GRIP | |
|-------------|-------|-----------------|-----------------|------------|------|----------|-------|--------|------|--------|----------------|----------|
| TCLL (roof) | 20.0 | Plate Grip DOL | 1.15 | TC | 0.62 | Vert(LL) | -0.16 | 10-11 | >999 | 240 | MT20 | 244/190 |
| Snow (Pf) | 20.0 | Lumber DOL | 1.15 | BC | 0.85 | Vert(CT) | -0.27 | 11-12 | >999 | 180 | | |
| TCDL | 10.0 | Rep Stress Incr | YES | WB | 0.31 | Horz(CT) | 0.11 | 7 | n/a | n/a | | |
| BCLL | 0.0* | Code | IRC2018/TPI2014 | Matrix-MSH | | | | | | | | |
| BCDL | 10.0 | | | | | | | | | | | |
| | | | | | | | | | | | Weight: 271 lb | FT = 20% |

LUMBER
TOP CHORD 2x6 SP No.2
BOT CHORD 2x6 SP No.2
WEBS 2x4 SP No.3 *Except* 10-4:2x4 SP No.2
WEDGE Left: 2x4 SP No.3
Right: 2x4 SP No.3

BRACING
TOP CHORD Structural wood sheathing directly applied or 3-7-0 oc purlins, except 2-0-0 oc purlins (4-7-0 max.): 4-5.
BOT CHORD Rigid ceiling directly applied or 10-0-0 oc bracing.
WEBS 1 Row at midpt 3-11, 4-10, 6-10

REACTIONS
(size) 2=0-3-8, 7=0-3-8
Max Horiz 2=128 (LC 18)
Max Uplift 2=-132 (LC 14), 7=-132 (LC 15)
Max Grav 2=1810 (LC 45), 7=1804 (LC 45)

FORCES
(lb) - Maximum Compression/Maximum Tension
TOP CHORD 4-5=-2095/414, 1-2=0/9, 2-4=-3147/405, 5-7=-3135/404, 7-8=0/9
BOT CHORD 2-12=-253/2728, 9-12=-254/2726, 7-9=-254/2718
WEBS 3-12=0/270, 3-11=-736/224, 4-11=-21/698, 4-10=-235/239, 5-10=0/671, 6-10=-734/225, 6-9=0/268

NOTES
1) Unbalanced roof live loads have been considered for this design.

- Wind: ASCE 7-16; Vult=130mph (3-second gust) Vasd=103mph; TCDL=6.0psf; BCDL=6.0psf; h=25ft; Cat. II; Exp B; Enclosed; MWFRS (envelope) exterior zone and C-C Exterior(2E) -0-3-14 to 3-6-14, Interior (1) 3-6-14 to 12-0-9, Exterior(2R) 12-0-9 to 26-11-7, Interior (1) 26-11-7 to 35-5-2, Exterior(2E) 35-5-2 to 39-3-13 zone; cantilever left and right exposed; end vertical left and right exposed; C-C for members and forces & MWFRS for reactions shown; Lumber DOL=1.60 plate grip DOL=1.60
- TCLL: ASCE 7-16; Pr=20.0 psf (roof LL: Lum DOL=1.15 Plate DOL=1.15); Pf=20.0 psf (Lum DOL=1.15 Plate DOL=1.15); Is=1.0; Rough Cat B; Fully Exp.; Ce=0.9; Cs=1.00; Ct=1.10
- Unbalanced snow loads have been considered for this design.
- This truss has been designed for greater of min roof live load of 12.0 psf or 1.00 times flat roof load of 20.0 psf on overhangs non-concurrent with other live loads.
- Provide adequate drainage to prevent water ponding.
- This truss has been designed for a 10.0 psf bottom chord live load nonconcurrent with any other live loads.
- * This truss has been designed for a live load of 20.0psf on the bottom chord in all areas where a rectangle 3-06-00 tall by 2-00-00 wide will fit between the bottom chord and any other members, with BCDL = 10.0psf.
- One H2.5A Simpson Strong-Tie connectors recommended to connect truss to bearing walls due to UPLIFT at jt(s) 2 and 7. This connection is for uplift only and does not consider lateral forces.
- This truss is designed in accordance with the 2018 International Residential Code sections R502.11.1 and R802.10.2 and referenced standard ANSI/TPI 1.
- Graphical purlin representation does not depict the size or the orientation of the purlin along the top and/or bottom chord.

LOAD CASE(S) Standard

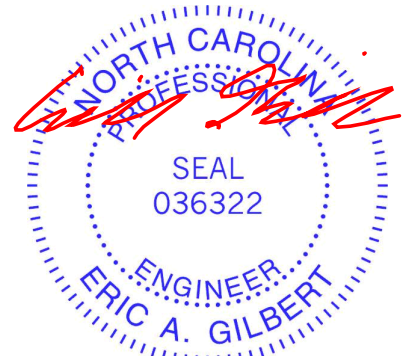

June 4, 2024

WARNING - Verify design parameters and READ NOTES ON THIS AND INCLUDED MITEK REFERENCE PAGE MII-7473 rev. 1/2/2023 BEFORE USE.

Design valid for use only with MiTek® connectors. This design is based only upon parameters shown, and is for an individual building component, not a truss system. Before use, the building designer must verify the applicability of design parameters and properly incorporate this design into the overall building design. Bracing indicated is to prevent buckling of individual truss web and/or chord members only. Additional temporary and permanent bracing is always required for stability and to prevent collapse with possible personal injury and property damage. For general guidance regarding the fabrication, storage, delivery, erection and bracing of trusses and truss systems, see **ANSI/TPI Quality Criteria and DSB-22** available from Truss Plate Institute (www.tpinst.org) and **BCSI Building Component Safety Information** available from the Structural Building Component Association (www.sbcacomponents.com)



818 Soundside Road
Edenton, NC 27932

| | | | | | | |
|-----------------|--------------|-------------------|----------|----------|--|-----------|
| Job 24070189 | Truss A08 | Truss Type Hip | Qty 1 | Ply 1 | 43 Mason Ridge-Roof-Cali M VMB GRH Job Reference (optional) | 165976670 |
|-----------------|--------------|-------------------|----------|----------|--|-----------|

Carter Components (Sanford, NC), Sanford, NC - 27332,

Run: 8.73 S Apr 25 2024 Print: 8.730 S Apr 25 2024 MiTek Industries, Inc. Mon Jun 03 09:40:53
ID:ftoJLOdMAmYtCtCW0gi3vAzwVFs-RfC?PsB70Hq3NSgPqnL8w3uITXbGKwRCDoi7J4zJC?f

Page: 1

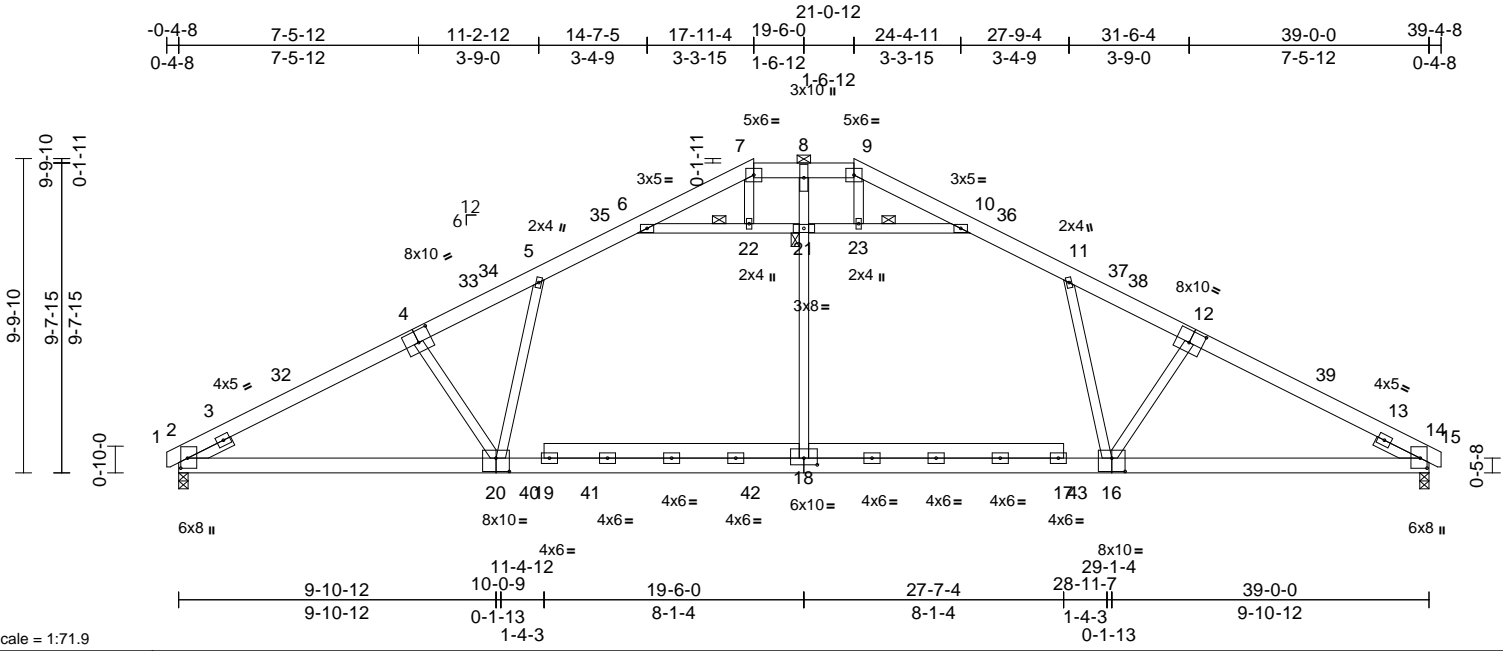

Scale = 1:71.9

Plate Offsets (X, Y): [2:0-3-12,0-2-9], [4:0-5-0,0-4-8], [12:0-5-0,0-4-8], [14:0-3-12,0-2-9], [16:0-5-0,0-5-0], [18:0-5-0,0-2-8], [20:0-5-0,0-5-0]

| Loading | (psf) | Spacing | 2-0-0 | CSI | DEFL | in | (loc) | l/defl | L/d | PLATES | GRIP | |
|-------------|-------|-----------------|-----------------|------------|------|----------|-------|--------|------|--------|----------------|----------|
| TCLL (roof) | 20.0 | Plate Grip DOL | 1.15 | TC | 0.65 | Vert(LL) | -0.53 | 16-30 | >878 | 240 | MT20 | 244/190 |
| Snow (Pf) | 20.0 | Lumber DOL | 1.15 | BC | 0.51 | Vert(CT) | -0.74 | 20-26 | >625 | 180 | | |
| TCDL | 10.0 | Rep Stress Incr | YES | WB | 0.75 | Horz(CT) | 0.07 | 14 | n/a | n/a | | |
| BCLL | 0.0* | Code | IRC2018/TPI2014 | Matrix-MSH | | | | | | | | |
| BCDL | 10.0 | | | | | | | | | | | |
| | | | | | | | | | | | Weight: 299 lb | FT = 20% |

LUMBER
TOP CHORD 2x6 SP No.2 *Except* 4-7,12-9:2x6 SP 2400F 2.0E
BOT CHORD 2x6 SP 2400F 2.0E *Except* 19-18,18-17:2x6 SP No.2
WEBS 2x4 SP No.3 *Except* 18-8:2x4 SP No.2
SLIDER Left 2x4 SP No.3 -- 1-6-0, Right 2x4 SP No.3 -- 1-6-0

BRACING
TOP CHORD Structural wood sheathing directly applied or 3-5-6 oc purlins, except 2-0-0 oc purlins (5-2-13 max.); 7-9.
BOT CHORD Rigid ceiling directly applied or 10-0-0 oc bracing.
WEBS 1 Row at midpt 6-21, 10-21
JOINTS 1 Brace at Jt(s): 21

REACTIONS
(size) 2=0-3-8, 14=0-3-8
Max Horiz 2=144 (LC 18)
Max Uplift 2=-26 (LC 14), 14=-69 (LC 15)
Max Grav 2=2066 (LC 45), 14=2023 (LC 45)

FORCES
(lb) - Maximum Compression/Maximum Tension
TOP CHORD 1-2=0/13, 2-5=-3508/113, 5-6=-2877/184, 6-7=-1441/0, 7-8=-1201/0, 8-9=-1217/0, 9-10=-1472/0, 10-11=-2887/173, 11-14=-3438/176, 14-15=0/13
BOT CHORD 2-14=-62/3061
WEBS 18-21=0/968, 8-21=0/915, 12-16=-528/329, 4-20=-597/259, 5-20=0/624, 11-16=-109/510, 6-22=-1591/289, 21-22=-1594/289, 21-23=-1574/310, 10-23=-1569/310, 7-22=-36/107, 9-23=-21/122

NOTES
1) Unbalanced roof live loads have been considered for this design.

- Wind: ASCE 7-16; Vult=130mph (3-second gust) Vasd=103mph; TCDL=6.0psf; BCDL=6.0psf; h=25ft; Cat. II; Exp B; Enclosed; MWFRS (envelope) exterior zone and C-C Exterior(2E) -0-3-14 to 3-6-14, Interior (1) 3-6-14 to 14-0-9, Exterior(2R) 14-0-9 to 24-9-7, Interior (1) 24-9-7 to 35-5-2, Exterior(2E) 35-5-2 to 39-3-13 zone;C-C for members and forces & MWFRS for reactions shown; Lumber DOL=1.60 plate grip DOL=1.60
- TCLL: ASCE 7-16; Pr=20.0 psf (roof LL: Lum DOL=1.15 Plate DOL=1.15); Pf=20.0 psf (Lum DOL=1.15 Plate DOL=1.15); Is=1.0; Rough Cat B; Fully Exp.; Ce=0.9; Cs=1.00; Ct=1.10
- Unbalanced snow loads have been considered for this design.
- This truss has been designed for greater of min roof live load of 12.0 psf or 1.00 times flat roof load of 20.0 psf on overhangs non-concurrent with other live loads.
- 200.0lb AC unit load placed on the bottom chord, 15-4-4 from left end, supported at two points, 5-0-0 apart.
- Provide adequate drainage to prevent water ponding.
- All plates are 4x6 MT20 unless otherwise indicated.
- This truss has been designed for a 10.0 psf bottom chord live load nonconcurrent with any other live loads.
- * This truss has been designed for a live load of 20.0psf on the bottom chord in all areas where a rectangle 3-06-00 tall by 2-00-00 wide will fit between the bottom chord and any other members, with BCDL = 10.0psf.
- One H2.5A Simpson Strong-Tie connectors recommended to connect truss to bearing walls due to UPLIFT at jt(s) 2 and 14. This connection is for uplift only and does not consider lateral forces.
- This truss is designed in accordance with the 2018 International Residential Code sections R502.11.1 and R802.10.2 and referenced standard ANSI/TPI 1.
- Graphical purlin representation does not depict the size or the orientation of the purlin along the top and/or bottom chord.

LOAD CASE(S) Standard



June 4, 2024

WARNING - Verify design parameters and READ NOTES ON THIS AND INCLUDED MITEK REFERENCE PAGE MII-7473 rev. 1/2/2023 BEFORE USE.
Design valid for use only with MiTek® connectors. This design is based only upon parameters shown, and is for an individual building component, not a truss system. Before use, the building designer must verify the applicability of design parameters and properly incorporate this design into the overall building design. Bracing indicated is to prevent buckling of individual truss web and/or chord members only. Additional temporary and permanent bracing is always required for stability and to prevent collapse with possible personal injury and property damage. For general guidance regarding the fabrication, storage, delivery, erection and bracing of trusses and truss systems, see **ANSI/TPI Quality Criteria and DSB-22** available from Truss Plate Institute (www.tpinst.org) and **BCSI Building Component Safety Information** available from the Structural Building Component Association (www.sbcacomponents.com)

ENGINEERING BY
TRENCO
A MiTek Affiliate
818 Soundside Road
Edenton, NC 27932

| | | | | | | |
|-----------------|--------------|----------------------|----------|----------|--|-----------|
| Job 24070189 | Truss A09 | Truss Type Common | Qty 5 | Ply 1 | 43 Mason Ridge-Roof-Cali M VMB GRH Job Reference (optional) | I65976671 |
|-----------------|--------------|----------------------|----------|----------|--|-----------|

Carter Components (Sanford, NC), Sanford, NC - 27332,

Run: 8.73 S Apr 25 2024 Print: 8.730 S Apr 25 2024 MiTek Industries, Inc. Mon Jun 03 09:40:53
ID:ftoJL0dMAMyCtCW0gi3vAzvVFs-RfC?PsB70Hq3NSgPqnL8w3ulTXbGKWrCDoi7J4zJC?f

Page: 1

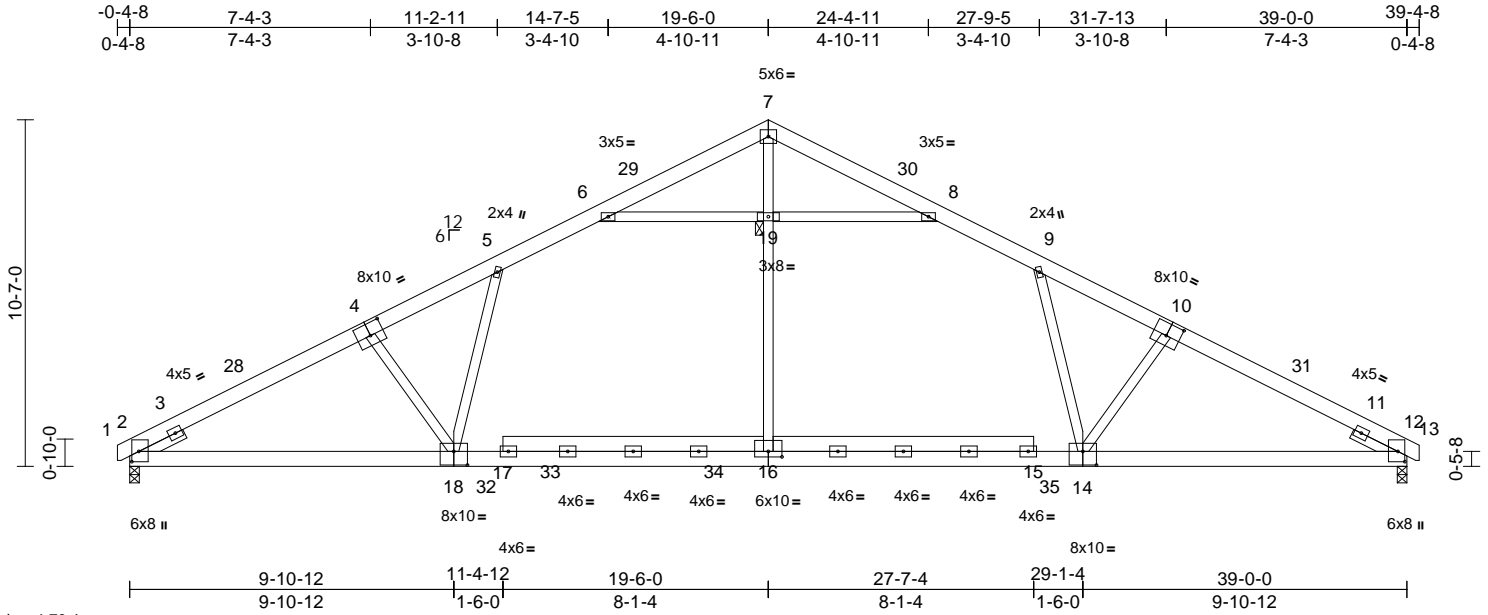

Scale = 1:70.4

Plate Offsets (X, Y): [2:0-3-12,0-2-9], [4:0-5-0,0-4-8], [10:0-5-0,0-4-8], [12:0-3-12,0-2-9], [14:0-5-0,0-5-0], [16:0-5-0,0-2-0], [18:0-5-0,0-5-0]

| Loading | (psf) | Spacing | 2-0-0 | CSI | DEFL | in | (loc) | l/defl | L/d | PLATES | GRIP | |
|-------------|-------|-----------------|-----------------|------------|------|----------|-------|--------|------|--------|----------------|----------|
| TCLL (roof) | 20.0 | Plate Grip DOL | 1.15 | TC | 0.96 | Vert(LL) | -0.56 | 14-26 | >831 | 240 | MT20 | 244/190 |
| Snow (Pf) | 20.0 | Lumber DOL | 1.15 | BC | 0.55 | Vert(CT) | -0.81 | 18-22 | >573 | 180 | | |
| TCDL | 10.0 | Rep Stress Incr | YES | WB | 0.83 | Horz(CT) | 0.07 | 12 | n/a | n/a | | |
| BCLL | 0.0* | Code | IRC2018/TPI2014 | Matrix-MSH | | | | | | | | |
| BCDL | 10.0 | | | | | | | | | | | |
| | | | | | | | | | | | Weight: 297 lb | FT = 20% |

LUMBER
TOP CHORD 2x6 SP No.2
BOT CHORD 2x6 SP 2400F 2.0E *Except* 16-15,17-16:2x6 SP No.2
WEBS 2x4 SP No.3 *Except* 16-7:2x4 SP No.2
SLIDER Left 2x4 SP No.3 -- 1-6-0, Right 2x4 SP No.3 -- 1-6-0

BRACING
TOP CHORD Structural wood sheathing directly applied.
BOT CHORD Rigid ceiling directly applied or 10-0-0 oc bracing.
JOINTS 1 Brace at Jt(s): 19

REACTIONS (size) 2=0-3-8, 12=0-3-8
Max Horiz 2=157 (LC 18)
Max Uplift 2=-36 (LC 14), 12=-78 (LC 15)
Max Grav 2=1919 (LC 3), 12=1876 (LC 3)

FORCES (lb) - Maximum Compression/Maximum Tension
TOP CHORD 1-2=0/13, 2-5=-3209/81, 5-6=-2610/148, 6-7=-1306/0, 7-8=-1329/0, 8-9=-2617/141, 9-12=-3144/138, 12-13=0/13
BOT CHORD 2-12=-68/2803
WEBS 16-19=0/1028, 7-19=0/1049, 9-14=-75/443, 10-14=-503/314, 5-18=0/543, 4-18=-568/247, 6-19=-1422/295, 8-19=-1405/312

NOTES
1) Unbalanced roof live loads have been considered for this design.
2) Wind: ASCE 7-16; Vult=130mph (3-second gust) Vasd=103mph; TCDL=6.0psf; BCDL=6.0psf; h=25ft; Cat. II; Exp B; Enclosed; MWFRS (envelope) exterior zone and C-C Exterior(2E) -0-3-14 to 3-6-14, Interior (1) 3-6-14 to 15-7-5, Exterior(2R) 15-7-5 to 23-4-11, Interior (1) 23-4-11 to 35-5-2, Exterior(2E) 35-5-2 to 39-3-13 zone;C-C for members and forces & MWFRS for reactions shown; Lumber DOL=1.60 plate grip DOL=1.60

- TCLL: ASCE 7-16; Pr=20.0 psf (roof LL: Lum DOL=1.15 Plate DOL=1.15); Pf=20.0 psf (Lum DOL=1.15 Plate DOL=1.15); Is=1.0; Rough Cat B; Fully Exp.; Ce=0.9; Cs=1.00; Ct=1.10
 - Unbalanced snow loads have been considered for this design.
 - This truss has been designed for greater of min roof live load of 12.0 psf or 1.00 times flat roof load of 20.0 psf on overhangs non-concurrent with other live loads.
 - 200.0lb AC unit load placed on the bottom chord, 15-4-4 from left end, supported at two points, 5-0-0 apart.
 - All plates are 4x6 MT20 unless otherwise indicated.
 - This truss has been designed for a 10.0 psf bottom chord live load nonconcurrent with any other live loads.
 - * This truss has been designed for a live load of 20.0psf on the bottom chord in all areas where a rectangle 3-06-00 tall by 2-00-00 wide will fit between the bottom chord and any other members, with BCDL = 10.0psf.
 - One H2.5A Simpson Strong-Tie connectors recommended to connect truss to bearing walls due to UPLIFT at jt(s) 2 and 12. This connection is for uplift only and does not consider lateral forces.
 - This truss is designed in accordance with the 2018 International Residential Code sections R502.11.1 and R802.10.2 and referenced standard ANSI/TPI 1.
- LOAD CASE(S)** Standard



June 4, 2024

WARNING - Verify design parameters and READ NOTES ON THIS AND INCLUDED MITEK REFERENCE PAGE MII-7473 rev. 1/2/2023 BEFORE USE.
Design valid for use only with MiTek® connectors. This design is based only upon parameters shown, and is for an individual building component, not a truss system. Before use, the building designer must verify the applicability of design parameters and properly incorporate this design into the overall building design. Bracing indicated is to prevent buckling of individual truss web and/or chord members only. Additional temporary and permanent bracing is always required for stability and to prevent collapse with possible personal injury and property damage. For general guidance regarding the fabrication, storage, delivery, erection and bracing of trusses and truss systems, see **ANSI/TPI Quality Criteria and DSB-22** available from Truss Plate Institute (www.tpinst.org) and **BCSI Building Component Safety Information** available from the Structural Building Component Association (www.sbcacomponents.com)



| | | | | | | |
|-----------------|--------------|----------------------|----------|----------|--|-----------|
| Job 24070189 | Truss A10 | Truss Type Common | Qty 7 | Ply 1 | 43 Mason Ridge-Roof-Cali M VMB GRH Job Reference (optional) | I65976672 |
|-----------------|--------------|----------------------|----------|----------|--|-----------|

Carter Components (Sanford, NC), Sanford, NC - 27332,

Run: 8.73 S Apr 25 2024 Print: 8.730 S Apr 25 2024 MiTek Industries, Inc. Mon Jun 03 09:40:54
ID:Evh8gst48bcRWOT7Y3HWizwjCh-RfC?PsB70Hq3NSgPqnL8w3ulTXbGKWrCdoi7J4zJC?f

Page: 1

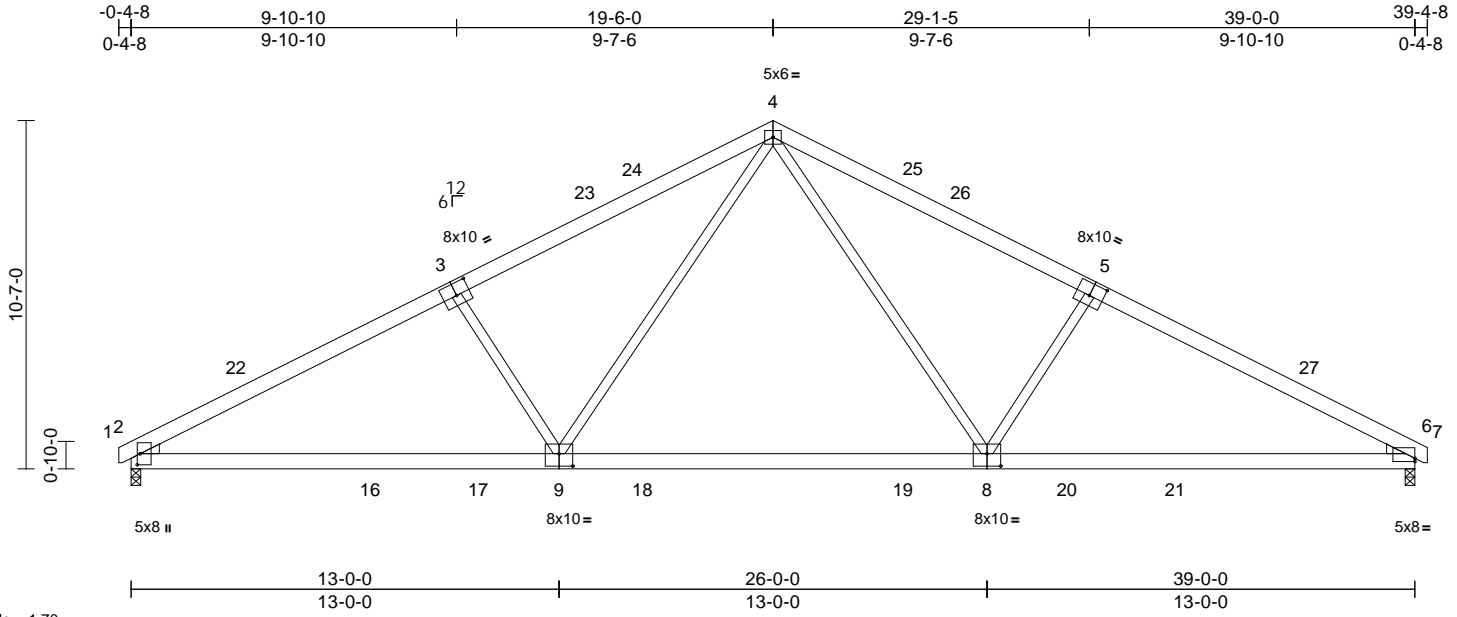

Scale = 1:70

Plate Offsets (X, Y): [2:0-4-0,0-1-1], [3:0-5-0,0-4-8], [5:0-5-0,0-4-8], [6:Edge,0-1-3], [8:0-5-0,0-4-8], [9:0-5-0,0-4-8]

| Loading | (psf) | Spacing | 2-0-0 | CSI | DEFL | in | (loc) | l/defl | L/d | PLATES | GRIP | |
|-------------|-------|-----------------|-----------------|------------|------|----------|-------|--------|------|--------|----------------|----------|
| TCLL (roof) | 20.0 | Plate Grip DOL | 1.15 | TC | 0.88 | Vert(LL) | -0.31 | 8-9 | >999 | 240 | MT20 | 244/190 |
| Snow (Pf) | 20.0 | Lumber DOL | 1.15 | BC | 1.00 | Vert(CT) | -0.51 | 8-9 | >926 | 180 | | |
| TCDL | 10.0 | Rep Stress Incr | YES | WB | 0.44 | Horz(CT) | 0.08 | 6 | n/a | n/a | | |
| BCLL | 0.0* | Code | IRC2018/TPI2014 | Matrix-MSH | | | | | | | | |
| BCDL | 10.0 | | | | | | | | | | | |
| | | | | | | | | | | | Weight: 249 lb | FT = 20% |

LUMBER

TOP CHORD 2x6 SP No.2
 BOT CHORD 2x6 SP No.2
 WEBS 2x4 SP No.3 *Except* 9-4,8-4:2x4 SP No.2
 WEDGE Left: 2x4 SP No.3
 Right: 2x4 SP No.3

BRACING

TOP CHORD Structural wood sheathing directly applied or 2-2-0 oc purlins.
 BOT CHORD Rigid ceiling directly applied or 2-2-0 oc bracing.

REACTIONS

(size) 2=0-3-8, 6=0-3-8
 Max Horiz 2=157 (LC 18)
 Max Uplift 2=-156 (LC 14), 6=-156 (LC 15)
 Max Grav 2=1782 (LC 3), 6=1782 (LC 3)

FORCES

(lb) - Maximum Compression/Maximum Tension
 TOP CHORD 1-2=0/9, 2-4=-2968/365, 4-6=-2980/364, 6-7=0/9
 BOT CHORD 2-6=-292/2574
 WEBS 3-9=-612/317, 4-9=-145/1172, 4-8=-144/1171, 5-8=-613/322

NOTES

- 1) Unbalanced roof live loads have been considered for this design.
- 2) Wind: ASCE 7-16; Vult=130mph (3-second gust) Vasd=103mph; TCDL=6.0psf; BCDL=6.0psf; h=25ft; Cat. II; Exp B; Enclosed; MWFRS (envelope) exterior zone and C-C Exterior(2E) 0-3-14 to 3-6-14, Interior (1) 3-6-14 to 15-7-5, Exterior(2R) 15-7-5 to 23-4-11, Interior (1) 23-4-11 to 35-5-2, Exterior(2E) 35-5-2 to 39-3-13 zone; cantilever left and right exposed; end vertical left and right exposed; C-C for members and forces & MWFRS for reactions shown; Lumber DOL=1.60 plate grip DOL=1.60

- 3) TCLL: ASCE 7-16; Pr=20.0 psf (roof LL: Lum DOL=1.15 Plate DOL=1.15); Pf=20.0 psf (Lum DOL=1.15 Plate DOL=1.15); Is=1.0; Rough Cat B; Fully Exp.; Ce=0.9; Cs=1.00; Ct=1.10
- 4) Unbalanced snow loads have been considered for this design.
- 5) This truss has been designed for greater of min roof live load of 12.0 psf or 1.00 times flat roof load of 20.0 psf on overhangs non-concurrent with other live loads.
- 6) This truss has been designed for a 10.0 psf bottom chord live load nonconcurrent with any other live loads.
- 7) * This truss has been designed for a live load of 20.0psf on the bottom chord in all areas where a rectangle 3-06-00 tall by 2-00-00 wide will fit between the bottom chord and any other members, with BCDL = 10.0psf.
- 8) One H2.5A Simpson Strong-Tie connectors recommended to connect truss to bearing walls due to UPLIFT at jt(s) 2 and 6. This connection is for uplift only and does not consider lateral forces.
- 9) This truss is designed in accordance with the 2018 International Residential Code sections R502.11.1 and R802.10.2 and referenced standard ANSI/TPI 1.

LOAD CASE(S) Standard

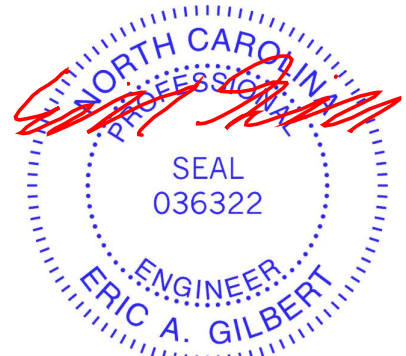

June 4, 2024

WARNING - Verify design parameters and READ NOTES ON THIS AND INCLUDED MITEK REFERENCE PAGE MII-7473 rev. 1/2/2023 BEFORE USE.

Design valid for use only with MiTek® connectors. This design is based only upon parameters shown, and is for an individual building component, not a truss system. Before use, the building designer must verify the applicability of design parameters and properly incorporate this design into the overall building design. Bracing indicated is to prevent buckling of individual truss web and/or chord members only. Additional temporary and permanent bracing is always required for stability and to prevent collapse with possible personal injury and property damage. For general guidance regarding the fabrication, storage, delivery, erection and bracing of trusses and truss systems, see **ANSI/TPI Quality Criteria and DSB-22** available from Truss Plate Institute (www.tpinst.org) and **BCSI Building Component Safety Information** available from the Structural Building Component Association (www.sbcacomponents.com)



818 Soundside Road
 Edenton, NC 27932

| | | | | | | |
|-----------------|--------------|----------------------------|----------|----------|--|-----------|
| Job 24070189 | Truss A11 | Truss Type Roof Special | Qty 3 | Ply 1 | 43 Mason Ridge-Roof-Cali M VMB GRH Job Reference (optional) | 165976673 |
|-----------------|--------------|----------------------------|----------|----------|--|-----------|

Carter Components (Sanford, NC), Sanford, NC - 27332,

Run: 8.73 S Apr 25 2024 Print: 8.730 S Apr 25 2024 MiTek Industries, Inc. Mon Jun 03 09:40:54
ID:rmlr88hAphVvRaslw2ITbwzjwAL-RfC?PsB70Hq3NSgPqnL8w3uITXbGKWrCDoi7J4zJC?f

Page: 1

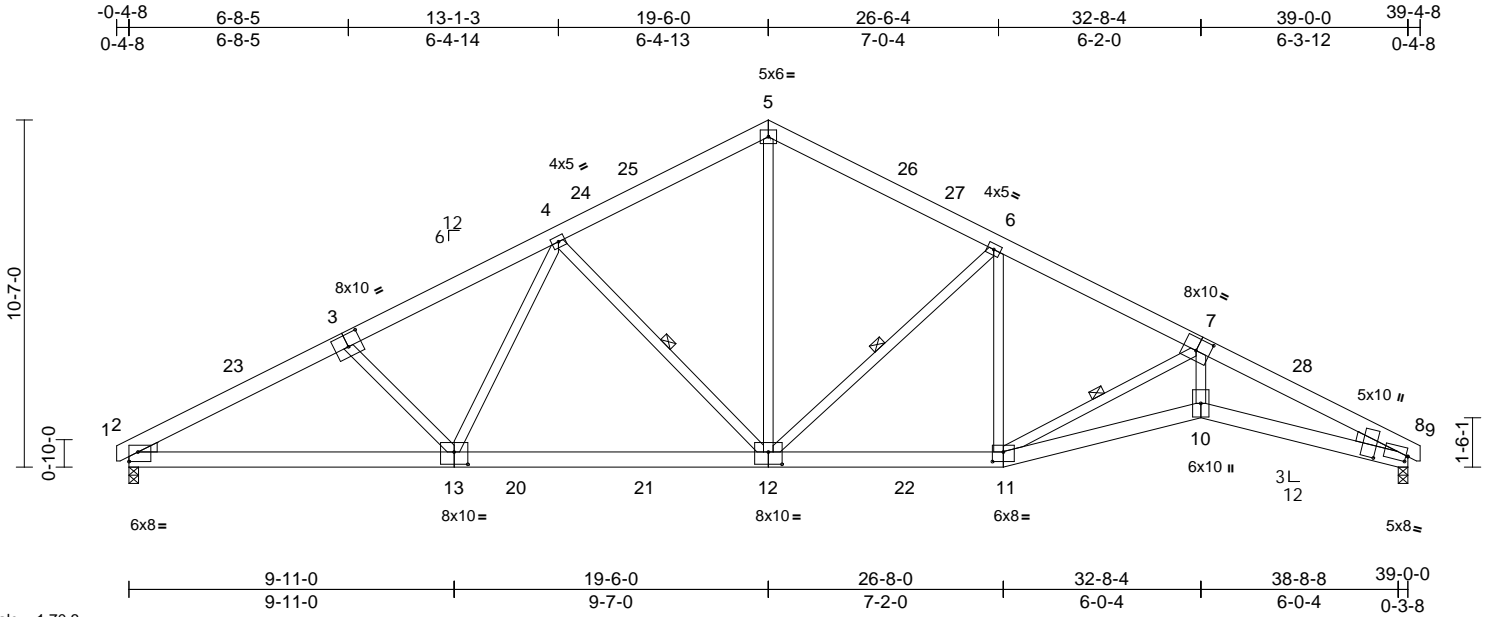

Plate Offsets (X, Y): [2:Edge,0-3-8], [3:0-5-0,0-4-8], [7:0-5-0,0-4-8], [8:0-0-12,0-2-1], [8:0-3-9,1-0-2], [11:0-4-0,0-3-8], [12:0-5-0,0-4-8], [13:0-5-0,0-4-8]

| Loading | (psf) | Spacing | 2-0-0 | CSI | DEFL | in | (loc) | l/defl | L/d | PLATES | GRIP | |
|-------------|-------|-----------------|-----------------|------------|------|----------|-------|--------|------|--------|----------------|----------|
| TCLL (roof) | 20.0 | Plate Grip DOL | 1.15 | TC | 0.50 | Vert(LL) | -0.24 | 10-11 | >999 | 240 | MT20 | 244/190 |
| Snow (Pf) | 20.0 | Lumber DOL | 1.15 | BC | 0.99 | Vert(CT) | -0.44 | 10-11 | >999 | 180 | | |
| TCDL | 10.0 | Rep Stress Incr | YES | WB | 0.87 | Horz(CT) | 0.19 | 8 | n/a | n/a | | |
| BCLL | 0.0* | Code | IRC2018/TPI2014 | Matrix-MSH | | | | | | | | |
| BCDL | 10.0 | | | | | | | | | | | |
| | | | | | | | | | | | Weight: 280 lb | FT = 20% |

LUMBER
TOP CHORD 2x6 SP No.2
BOT CHORD 2x6 SP No.2 *Except* 10-8:2x6 SP 2400F 2.0E
WEBS 2x4 SP No.3
WEDGE Left: 2x4 SP No.3
Right: 2x4 SP No.3

BRACING
TOP CHORD Structural wood sheathing directly applied or 2-10-15 oc purlins.
BOT CHORD Rigid ceiling directly applied or 10-0-0 oc bracing, Except:
2-2-0 oc bracing: 10-11.
WEBS 1 Row at midpt 4-12, 6-12, 7-11

REACTIONS (size) 2=0-3-8, 8=0-3-8
Max Horiz 2=-157 (LC 15)
Max Uplift 2=-156 (LC 14), 8=-156 (LC 15)
Max Grav 2=1727 (LC 3), 8=1723 (LC 3)

FORCES (lb) - Maximum Compression/Maximum Tension
TOP CHORD 1-2=0/9, 2-4=-2965/319, 4-5=-1990/330, 5-6=-2002/327, 6-8=-4915/439, 8-9=0/9
BOT CHORD 2-11=-326/2578, 10-11=-320/4384, 8-10=-320/4406
WEBS 4-13=-25/584, 4-12=-772/238, 5-12=-109/1412, 6-12=-851/234, 6-11=0/403, 7-11=-2270/252, 7-10=-80/2104, 3-13=-300/189

NOTES
1) Unbalanced roof live loads have been considered for this design.

- Wind: ASCE 7-16; Vult=130mph (3-second gust) Vasd=103mph; TCDL=6.0psf; BCDL=6.0psf; h=25ft; Cat. II; Exp B; Enclosed; MWFRS (envelope) exterior zone and C-C Exterior(2E) -0-3-14 to 3-6-14, Interior (1) 3-6-14 to 15-7-5, Exterior(2R) 15-7-5 to 23-4-11, Interior (1) 23-4-11 to 35-5-2, Exterior(2E) 35-5-2 to 39-3-13 zone;C-C for members and forces & MWFRS for reactions shown; Lumber DOL=1.60 plate grip DOL=1.60
- TCLL: ASCE 7-16; Pr=20.0 psf (roof LL: Lum DOL=1.15 Plate DOL=1.15); Pf=20.0 psf (Lum DOL=1.15 Plate DOL=1.15); Is=1.0; Rough Cat B; Fully Exp.; Ce=0.9; Cs=1.00; Ct=1.10
- Unbalanced snow loads have been considered for this design.
- This truss has been designed for greater of min roof live load of 12.0 psf or 1.00 times flat roof load of 20.0 psf on overhangs non-concurrent with other live loads.
- This truss has been designed for a 10.0 psf bottom chord live load nonconcurrent with any other live loads.
- * This truss has been designed for a live load of 20.0psf on the bottom chord in all areas where a rectangle 3-06-00 tall by 2-00-00 wide will fit between the bottom chord and any other members, with BCDL = 10.0psf.
- Bearing at joint(s) 8 considers parallel to grain value using ANSI/TPI 1 angle to grain formula. Building designer should verify capacity of bearing surface.
- One H2.5A Simpson Strong-Tie connectors recommended to connect truss to bearing walls due to UPLIFT at jt(s) 8 and 2. This connection is for uplift only and does not consider lateral forces.
- This truss is designed in accordance with the 2018 International Residential Code sections R502.11.1 and R802.10.2 and referenced standard ANSI/TPI 1.

LOAD CASE(S) Standard

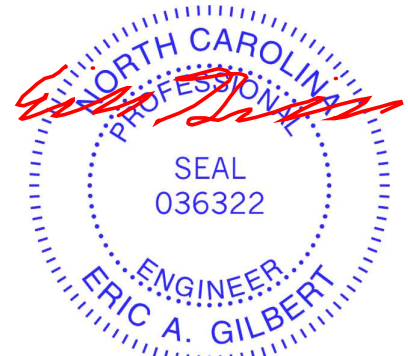

June 4, 2024

WARNING - Verify design parameters and READ NOTES ON THIS AND INCLUDED MITEK REFERENCE PAGE MII-7473 rev. 1/2/2023 BEFORE USE.

Design valid for use only with MiTek® connectors. This design is based only upon parameters shown, and is for an individual building component, not a truss system. Before use, the building designer must verify the applicability of design parameters and properly incorporate this design into the overall building design. Bracing indicated is to prevent buckling of individual truss web and/or chord members only. Additional temporary and permanent bracing is always required for stability and to prevent collapse with possible personal injury and property damage. For general guidance regarding the fabrication, storage, delivery, erection and bracing of trusses and truss systems, see **ANSI/TPI Quality Criteria and DSB-22** available from Truss Plate Institute (www.tpinst.org) and **BCSI Building Component Safety Information** available from the Structural Building Component Association (www.sbcacomponents.com)



818 Soundside Road
Edenton, NC 27932

| | | | | | | |
|-----------------|--------------|----------------------------|----------|----------|--|-----------|
| Job 24070189 | Truss A12 | Truss Type Roof Special | Qty 4 | Ply 1 | 43 Mason Ridge-Roof-Cali M VMB GRH Job Reference (optional) | 165976674 |
|-----------------|--------------|----------------------------|----------|----------|--|-----------|

Carter Components (Sanford, NC), Sanford, NC - 27332,

Run: 8.73 S Apr 25 2024 Print: 8.730 S Apr 25 2024 MiTek Industries, Inc. Mon Jun 03 09:40:54
ID:zRFAQ5VdjTHmpTlx8qwP8LzWj80-RfC?PsB70Hq3NSgPqnl8w3uITXbGKWrCDoi7J4zJC?f

Page: 1

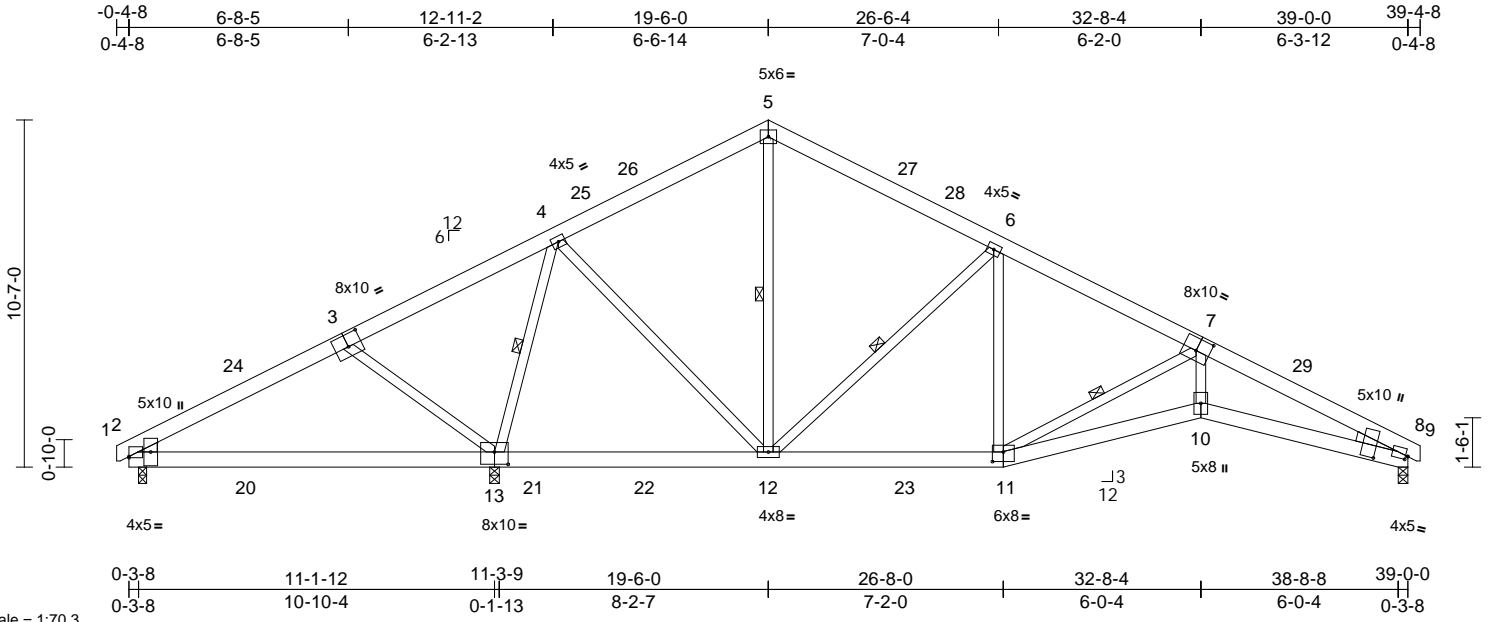

Scale = 1:70.3
Plate Offsets (X, Y): [2:Edge,0-0-7], [3:0-5-0,0-4-8], [7:0-5-0,0-4-8], [8:0-0-14,0-1-5], [8:0-3-9,1-0-2], [11:0-4-0,0-3-8], [13:0-5-0,0-4-8]

| Loading | (psf) | Spacing | 2-0-0 | CSI | DEFL | in | (loc) | l/defl | L/d | PLATES | GRIP | |
|-------------|-------|-----------------|-----------------|------------|------|----------|-------|--------|------|--------|----------------|----------|
| TCLL (roof) | 20.0 | Plate Grip DOL | 1.15 | TC | 0.45 | Vert(LL) | 0.18 | 13-16 | >753 | 240 | MT20 | 244/190 |
| Snow (Pf) | 20.0 | Lumber DOL | 1.15 | BC | 0.59 | Vert(CT) | 0.13 | 13-16 | >999 | 180 | | |
| TCDL | 10.0 | Rep Stress Incr | YES | WB | 0.54 | Horz(CT) | 0.08 | 8 | n/a | n/a | | |
| BCLL | 0.0* | Code | IRC2018/TPI2014 | Matrix-MSH | | | | | | | | |
| BCDL | 10.0 | | | | | | | | | | | |
| | | | | | | | | | | | Weight: 281 lb | FT = 20% |

LUMBER
TOP CHORD 2x6 SP No.2
BOT CHORD 2x6 SP No.2
WEBS 2x4 SP No.3
WEDGE Left: 2x4 SP No.3
Right: 2x4 SP No.3

BRACING
TOP CHORD Structural wood sheathing directly applied or 4-2-12 oc purlins.
BOT CHORD Rigid ceiling directly applied or 6-0-0 oc bracing.
WEBS 1 Row at midpt 4-13, 5-12, 6-12, 7-11

REACTIONS (size) 2=0-3-0, 8=0-3-8, 13=0-3-8
Max Horiz 2=-157 (LC 15)
Max Uplift 2=-129 (LC 11), 8=-126 (LC 15), 13=-173 (LC 14)
Max Grav 2=273 (LC 34), 8=1099 (LC 6), 13=2269 (LC 3)

FORCES (lb) - Maximum Compression/Maximum Tension
TOP CHORD 1-2=0/9, 2-4=-147/823, 4-5=-602/249, 5-6=-626/249, 6-8=-2840/333, 8-9=0/9
BOT CHORD 2-12=-457/224, 11-12=-65/1109, 10-11=-225/2524, 8-10=-225/2541
WEBS 4-13=-1626/181, 4-12=-55/1066, 5-12=-31/212, 6-12=-895/232, 6-11=0/473, 7-11=-1530/221, 7-10=-37/1316, 3-13=-465/260

NOTES
1) Unbalanced roof live loads have been considered for this design.

- Wind: ASCE 7-16; Vult=130mph (3-second gust) Vasd=103mph; TCDL=6.0psf; BCDL=6.0psf; h=25ft; Cat. II; Exp B; Enclosed; MWFRS (envelope) exterior zone and C-C Exterior(2E) -0-3-14 to 3-6-14, Interior (1) 3-6-14 to 15-7-5, Exterior(2R) 15-7-5 to 23-4-11, Interior (1) 23-4-11 to 35-5-2, Exterior(2E) 35-5-2 to 39-3-13 zone; porch left exposed; C-C for members and forces & MWFRS for reactions shown; Lumber DOL=1.60 plate grip DOL=1.60
- TCLL: ASCE 7-16; Pr=20.0 psf (roof LL: Lum DOL=1.15 Plate DOL=1.15); Pf=20.0 psf (Lum DOL=1.15 Plate DOL=1.15); Is=1.0; Rough Cat B; Fully Exp.; Ce=0.9; Cs=1.00; Ct=1.10
- Unbalanced snow loads have been considered for this design.
- This truss has been designed for greater of min roof live load of 12.0 psf or 1.00 times flat roof load of 20.0 psf on overhangs non-concurrent with other live loads.
- This truss has been designed for a 10.0 psf bottom chord live load nonconcurrent with any other live loads.
- * This truss has been designed for a live load of 20.0psf on the bottom chord in all areas where a rectangle 3-06-00 tall by 2-00-00 wide will fit between the bottom chord and any other members, with BCDL = 10.0psf.
- Bearing at joint(s) 8 considers parallel to grain value using ANSI/TPI 1 angle to grain formula. Building designer should verify capacity of bearing surface.
- One H2.5A Simpson Strong-Tie connectors recommended to connect truss to bearing walls due to UPLIFT at jt(s) 2, 13, and 8. This connection is for uplift only and does not consider lateral forces.
- This truss is designed in accordance with the 2018 International Residential Code sections R502.11.1 and R802.10.2 and referenced standard ANSI/TPI 1.

LOAD CASE(S) Standard



June 4, 2024

| | | | | | | |
|-----------------|--------------|----------------------------|----------|----------|--|-----------|
| Job 24070189 | Truss A13 | Truss Type Roof Special | Qty 1 | Ply 1 | 43 Mason Ridge-Roof-Cali M VMB GRH Job Reference (optional) | 165976675 |
|-----------------|--------------|----------------------------|----------|----------|--|-----------|

Carter Components (Sanford, NC), Sanford, NC - 27332,

Run: 8.73 S Apr 25 2024 Print: 8.730 S Apr 25 2024 MiTek Industries, Inc. Mon Jun 03 09:40:54

Page: 1

ID: 7cSAj4o96MMcJVXf9hWJZzj0p-RfC?PsB70Hq3NSgPqnL8w3uITXbGKwRcDoi7J4zJC7f

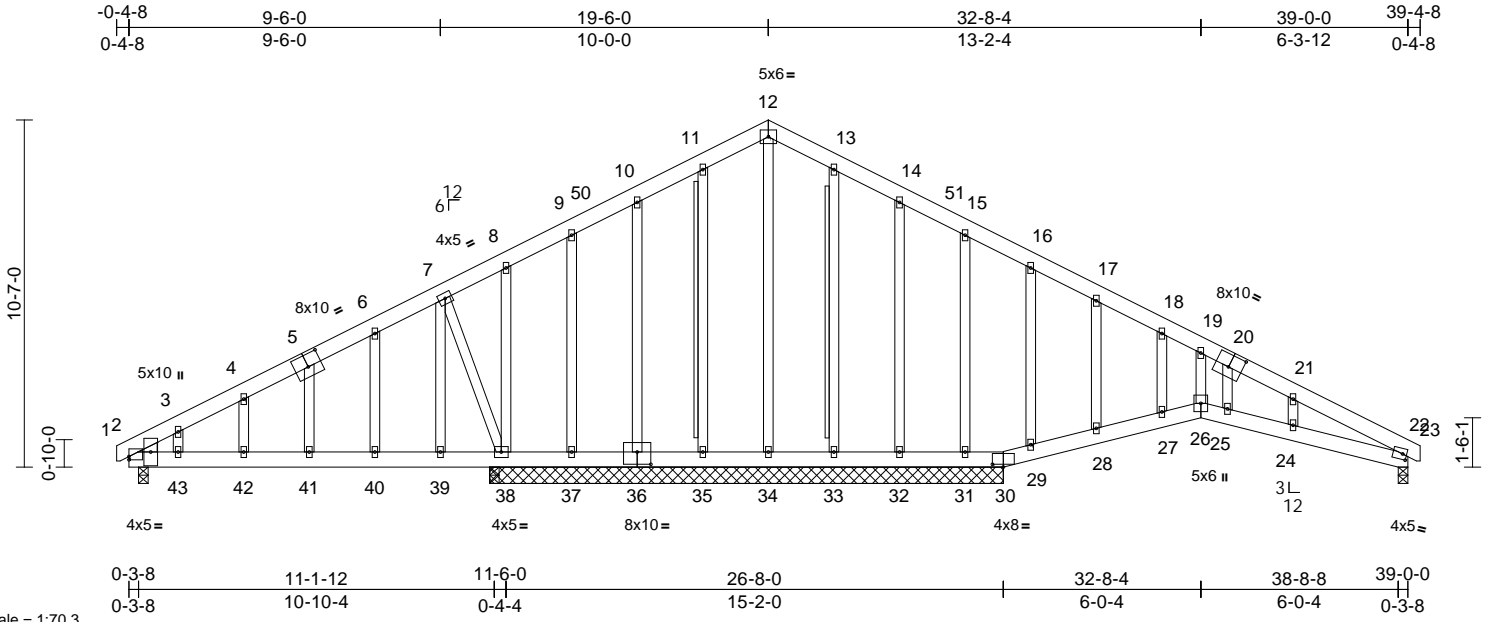

Plate Offsets (X, Y): [2:Edge,0-1-3], [5:0-5-0,0-4-8], [20:0-5-0,0-4-8], [22:0-1-7,0-2-0], [30:0-4-0,0-1-0], [36:0-5-0,0-4-8]

| Loading | (psf) | Spacing | 2-0-0 | CSI | DEFL | in | (loc) | l/defl | L/d | PLATES | GRIP |
|----------------|-------|-----------------|-----------------|------------|----------|-------|-------|--------|-----|--------|----------|
| TCLL (roof) | 20.0 | Plate Grip DOL | 1.15 | TC | Vert(LL) | 0.08 | 41-42 | >999 | 240 | MT20 | 244/190 |
| Snow (Pf) | 20.0 | Lumber DOL | 1.15 | BC | Vert(CT) | -0.12 | 41-42 | >999 | 180 | | |
| TCDL | 10.0 | Rep Stress Incr | YES | WB | Horz(CT) | -0.02 | 30 | n/a | n/a | | |
| BCLL | 0.0* | Code | IRC2018/TPI2014 | Matrix-MSH | | | | | | | |
| BCDL | 10.0 | | | | | | | | | | |
| Weight: 340 lb | | | | | | | | | | | FT = 20% |

LUMBER
TOP CHORD 2x6 SP No.2
BOT CHORD 2x6 SP No.2
WEBS 2x4 SP No.3
OTHERS 2x4 SP No.3 *Except* 0-0,0-0:2x4 SP No.2 (flat)
WEDGE Left: 2x4 SP No.3

BRACING
TOP CHORD Structural wood sheathing directly applied or 6-0-0 oc purlins.
BOT CHORD Rigid ceiling directly applied or 6-0-0 oc bracing.
WEBS T-Brace: 2x4 SP No.2 - 11-35, 13-33
Fasten (2X) T and I braces to narrow edge of web with 10d (0.131"x3") nails, 6in o.c., with 3in minimum end distance.
Brace must cover 90% of web length.

REACTIONS (size)
2=0-3-8, 22=0-3-8, 30=15-8-0,
31=15-8-0, 32=15-8-0, 33=15-8-0,
34=15-8-0, 35=15-8-0, 36=15-8-0,
37=15-8-0, 38=15-8-0
Max Horiz 2=1200 (LC 1), 22=1200 (LC 1)
Max Uplift 2=-43 (LC 14), 22=-50 (LC 15),
30=-226 (LC 15), 31=-121 (LC 35),
32=-53 (LC 15), 33=-17 (LC 15),
34=-88 (LC 1), 35=-21 (LC 14),
36=-49 (LC 14), 37=-66 (LC 14),
38=-131 (LC 14)
Max Grav 2=643 (LC 1), 22=652 (LC 1),
30=801 (LC 35), 31=32 (LC 15),
32=244 (LC 22), 33=195 (LC 22),
34=139 (LC 15), 35=206 (LC 21),
36=235 (LC 21), 37=223 (LC 21),
38=489 (LC 34)

FORCES (lb) - Maximum Compression/Maximum Tension

TOP CHORD 1-2=0/9, 2-3=-705/22, 3-4=-711/41,
4-6=-656/86, 6-7=-589/108, 7-8=-443/125,
8-9=-347/144, 9-10=-360/169,
10-11=-367/199, 11-12=-345/233,
12-13=-345/233, 13-14=-366/199,
14-15=-376/160, 15-16=-371/131,
16-17=-319/107, 17-18=-365/85,
18-19=-366/64, 19-21=-347/50,
21-22=-417/13, 22-23=0/9
BOT CHORD 2-43=-762/272, 42-43=-762/272,
41-42=-762/272, 40-41=-764/274,
39-40=-764/274, 38-39=-764/274,
37-38=-905/284, 35-37=-905/284,
34-35=-905/284, 33-34=-905/284,
32-33=-905/284, 31-32=-905/284,
30-31=-905/284, 29-30=-1011/317,
28-29=-946/298, 27-28=-934/295,
26-27=-907/285, 25-26=-885/275,
24-25=-918/285, 22-24=-1019/290
WEBS 19-26=-100/29, 12-34=-116/160,
11-35=-164/49, 10-36=-202/77,
9-37=-154/75, 8-38=-2/111, 7-39=-81/362,
6-40=0/70, 5-41=-115/72, 4-42=0/54,
3-43=-62/45, 13-33=-166/49, 14-32=-163/67,
15-31=-149/71, 16-29=-238/99, 17-28=-6/47,
18-27=-83/56, 20-25=-163/85, 21-24=-18/58,
7-38=-772/243

NOTES
1) Unbalanced roof live loads have been considered for this design.

- Wind: ASCE 7-16; Vult=130mph (3-second gust) Vasd=103mph; TCDL=6.0psf; BCDL=6.0psf; h=25ft; Cat. II; Exp B; Enclosed; MWFRS (envelope) exterior zone and C-C Exterior(2E) -0-3-14 to 3-6-0, Interior (1) 3-6-0 to 15-6-0, Exterior(2R) 15-6-0 to 23-6-0, Interior (1) 23-6-0 to 35-5-2, Exterior(2E) 35-5-2 to 39-3-13 zone; cantilever left and right exposed ; end vertical left and right exposed;C-C for members and forces & MWFRS for reactions shown; Lumber DOL=1.60 plate grip DOL=1.60
- Truss designed for wind loads in the plane of the truss only. For studs exposed to wind (normal to the face), see Standard Industry Gable End Details as applicable, or consult qualified building designer as per ANSI/TPI 1.
- TCLL: ASCE 7-16; Pr=20.0 psf (roof LL: Lum DOL=1.15 Plate DOL=1.15); Pf=20.0 psf (Lum DOL=1.15 Plate DOL=1.15); Is=1.0; Rough Cat B; Fully Exp.; Ce=0.9; Cs=1.00; Ct=1.10
- Unbalanced snow loads have been considered for this design.



June 4, 2024

Continued on page 2

WARNING - Verify design parameters and READ NOTES ON THIS AND INCLUDED MITEK REFERENCE PAGE MII-7473 rev. 1/2/2023 BEFORE USE.
Design valid for use only with MiTek® connectors. This design is based only upon parameters shown, and is for an individual building component, not a truss system. Before use, the building designer must verify the applicability of design parameters and properly incorporate this design into the overall building design. Bracing indicated is to prevent buckling of individual truss web and/or chord members only. Additional temporary and permanent bracing is always required for stability and to prevent collapse with possible personal injury and property damage. For general guidance regarding the fabrication, storage, delivery, erection and bracing of trusses and truss systems, see **ANSI/TPI1 Quality Criteria and DSB-22** available from Truss Plate Institute (www.tpinst.org) and **BCSI Building Component Safety Information** available from the Structural Building Component Association (www.sbcacomponents.com)



818 Soundside Road
Edenton, NC 27932

| | | | | | | |
|-----------------|--------------|----------------------------|----------|----------|--|-----------|
| Job 24070189 | Truss A13 | Truss Type Roof Special | Qty 1 | Ply 1 | 43 Mason Ridge-Roof-Cali M VMB GRH Job Reference (optional) | I65976675 |
|-----------------|--------------|----------------------------|----------|----------|--|-----------|

Carter Components (Sanford, NC), Sanford, NC - 27332,

Run: 8.73 S Apr 25 2024 Print: 8.730 S Apr 25 2024 MiTek Industries, Inc. Mon Jun 03 09:40:54
ID: _7cSAj4o96MMcJVXf9hWJZzWj0p-RfC?PsB70Hq3NSgPqnL8w3uITxbGKWrcDoi7J4zJC?f

Page: 2

- 6) This truss has been designed for greater of min roof live load of 12.0 psf or 1.00 times flat roof load of 20.0 psf on overhangs non-concurrent with other live loads.
- 7) All plates are 2x4 MT20 unless otherwise indicated.
- 8) Gable studs spaced at 2-0-0 oc.
- 9) This truss has been designed for a 10.0 psf bottom chord live load nonconcurrent with any other live loads.
- 10) * This truss has been designed for a live load of 20.0psf on the bottom chord in all areas where a rectangle 3-06-00 tall by 2-00-00 wide will fit between the bottom chord and any other members.
- 11) Bearings are assumed to be: , Joint 2 User Defined , Joint 31 User Defined .
- 12) Bearing at joint(s) 22 considers parallel to grain value using ANSI/TPI 1 angle to grain formula. Building designer should verify capacity of bearing surface.
- 13) N/A

- 14) Non Standard bearing condition. Review required.
- 15) This truss is designed in accordance with the 2018 International Residential Code sections R502.11.1 and R802.10.2 and referenced standard ANSI/TPI 1.
- 16) Warning: Additional permanent and stability bracing for truss system (not part of this component design) is always required.

LOAD CASE(S) Standard

WARNING - Verify design parameters and READ NOTES ON THIS AND INCLUDED MITEK REFERENCE PAGE MII-7473 rev. 1/2/2023 BEFORE USE.

Design valid for use only with MiTek® connectors. This design is based only upon parameters shown, and is for an individual building component, not a truss system. Before use, the building designer must verify the applicability of design parameters and properly incorporate this design into the overall building design. Bracing indicated is to prevent buckling of individual truss web and/or chord members only. Additional temporary and permanent bracing is always required for stability and to prevent collapse with possible personal injury and property damage. For general guidance regarding the fabrication, storage, delivery, erection and bracing of trusses and truss systems, see **ANSI/TPI1 Quality Criteria and DSB-22** available from Truss Plate Institute (www.tpinst.org) and **BCSI Building Component Safety Information** available from the Structural Building Component Association (www.sbcacomponents.com)



818 Soundside Road
Edenton, NC 27932

| | | | | | | |
|-----------------|--------------|--------------------------------------|----------|----------|--|-----------|
| Job 24070189 | Truss B01 | Truss Type Common Supported Gable | Qty 1 | Ply 1 | 43 Mason Ridge-Roof-Cali M VMB GRH Job Reference (optional) | 165976676 |
|-----------------|--------------|--------------------------------------|----------|----------|--|-----------|

Carter Components (Sanford, NC), Sanford, NC - 27332,

Run: 8.73 S Apr 25 2024 Print: 8.730 S Apr 25 2024 MiTek Industries, Inc. Mon Jun 03 09:40:54
ID:Ts5oRqu4mUn5A3y3B3BrkuzwimG-RfC?PsB70Hq3NSgPqnL8w3uITXbGKWrCDoi7J4zJC?f

Page: 1

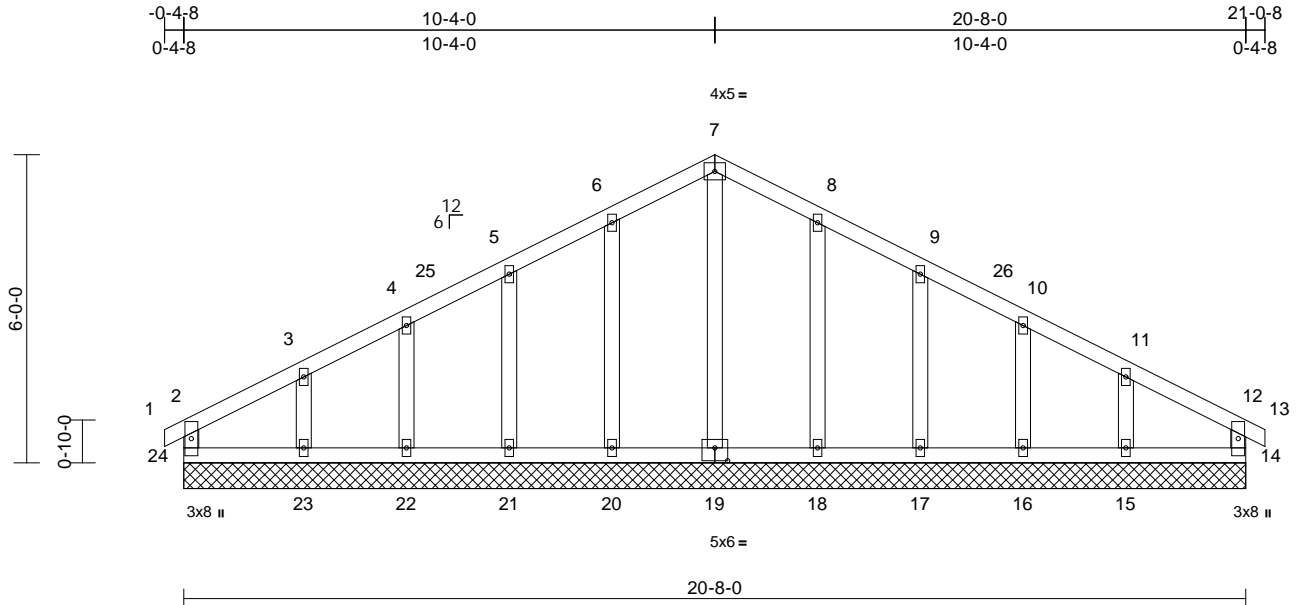

Scale = 1:44.8

Plate Offsets (X, Y): [19:0-3-0,0-3-0]

| Loading | (psf) | Spacing | 1-11-4 | CSI | DEFL | in | (loc) | l/defl | L/d | PLATES | GRIP |
|-------------|-------|-----------------|-----------------|-----------|----------|------|-------|--------|-----|----------------|----------|
| TCLL (roof) | 20.0 | Plate Grip DOL | 1.15 | TC | Vert(LL) | n/a | - | n/a | 999 | MT20 | 244/190 |
| Snow (Pf) | 20.0 | Lumber DOL | 1.15 | BC | Vert(CT) | n/a | - | n/a | 999 | | |
| TCDL | 10.0 | Rep Stress Incr | YES | WB | Horz(CT) | 0.00 | 14 | n/a | n/a | | |
| BCLL | 0.0* | Code | IRC2018/TPI2014 | Matrix-MR | | | | | | | |
| BCDL | 10.0 | | | | | | | | | | |
| | | | | | | | | | | Weight: 111 lb | FT = 20% |

| LUMBER | |
|-----------|-------------|
| TOP CHORD | 2x4 SP No.2 |
| BOT CHORD | 2x4 SP No.2 |
| WEBS | 2x4 SP No.3 |
| OTHERS | 2x4 SP No.3 |

| BRACING | |
|-----------|---|
| TOP CHORD | Structural wood sheathing directly applied or 6'-0" oc purlins, except end verticals. |
| BOT CHORD | Rigid ceiling directly applied or 10'-0" oc bracing. |

| REACTIONS | (size) |
|------------|--|
| Max Horiz | 24=80 (LC 12) |
| Max Uplift | 14=16 (LC 14), 15=72 (LC 15), 16=34 (LC 15), 17=45 (LC 15), 18=42 (LC 15), 20=42 (LC 14), 21=46 (LC 14), 22=33 (LC 14), 23=77 (LC 14), 24=26 (LC 15) |
| Max Grav | 14=118 (LC 1), 15=174 (LC 35), 16=164 (LC 22), 17=222 (LC 22), 18=237 (LC 22), 19=144 (LC 27), 20=237 (LC 21), 21=222 (LC 21), 22=164 (LC 21), 23=174 (LC 34), 24=118 (LC 1) |

| FORCES | (lb) - Maximum Compression/Maximum Tension |
|-----------|--|
| TOP CHORD | 2-24=-100/79, 1-2=0/14, 2-3=-78/53, 3-4=-57/90, 4-5=-58/131, 5-6=-74/178, 6-7=-89/221, 7-8=-89/221, 8-9=-74/178, 9-10=-58/131, 10-11=-48/90, 11-12=-68/39, 12-13=0/14, 12-14=-100/79 |
| BOT CHORD | 23-24=-23/49, 22-23=-23/49, 21-22=-23/49, 20-21=-23/49, 18-20=-23/49, 17-18=-23/49, 16-17=-23/49, 15-16=-23/49, 14-15=-23/49 |

| WEBS | |
|------|--|
| 7-19 | =-134/21, 6-20=-198/73, 5-21=-183/81, 4-22=-128/68, 3-23=-128/119, 8-18=-198/73, 9-17=-183/81, 10-16=-128/68, 11-15=-128/119 |

- NOTES**
- Unbalanced roof live loads have been considered for this design.
 - Wind: ASCE 7-16; Vult=130mph (3-second gust) Vasd=103mph; TCCL=6.0psf; BCCL=6.0psf; h=25ft; Cat. II; Exp B; Enclosed; MWFRS (envelope) exterior zone and C-C Corner(3E) 7-4-0 to 13-4-0, Exterior(2N) 2-4-0 to 7-4-0, Corner(3R) 7-4-0 to 13-4-0, Exterior(2N) 13-4-0 to 18-0-8, Corner(3E) 18-0-8 to 21-0-8 zone; end vertical left and right exposed; C-C for members and forces & MWFRS for reactions shown; Lumber DOL=1.60 plate grip DOL=1.60
 - Truss designed for wind loads in the plane of the truss only. For studs exposed to wind (normal to the face), see Standard Industry Gable End Details as applicable, or consult qualified building designer as per ANSI/TPI 1.
 - TCLL: ASCE 7-16; Pr=20.0 psf (roof LL: Lum DOL=1.15 Plate DOL=1.15); Pf=20.0 psf (Lum DOL=1.15 Plate DOL=1.15); Is=1.0; Rough Cat B; Fully Exp.; Ce=0.9; Cs=1.00; Ct=1.10
 - Unbalanced snow loads have been considered for this design.
 - This truss has been designed for greater of min roof live load of 12.0 psf or 1.00 times flat roof load of 20.0 psf on overhangs non-concurrent with other live loads.
 - All plates are 2x4 MT20 unless otherwise indicated.
 - Gable requires continuous bottom chord bearing.
 - Truss to be fully sheathed from one face or securely braced against lateral movement (i.e. diagonal web).
 - Gable studs spaced at 2'-0" oc.
 - This truss has been designed for a 10.0 psf bottom chord live load nonconcurrent with any other live loads.

- * This truss has been designed for a live load of 20.0psf on the bottom chord in all areas where a rectangle 3'-06"-00 tall by 2'-00"-00 wide will fit between the bottom chord and any other members.
 - Provide mechanical connection (by others) of truss to bearing plate capable of withstanding 26 lb uplift at joint 24, 16 lb uplift at joint 14, 42 lb uplift at joint 20, 46 lb uplift at joint 21, 33 lb uplift at joint 22, 77 lb uplift at joint 23, 42 lb uplift at joint 18, 45 lb uplift at joint 17, 34 lb uplift at joint 16 and 72 lb uplift at joint 15.
 - This truss is designed in accordance with the 2018 International Residential Code sections R502.11.1 and R802.10.2 and referenced standard ANSI/TPI 1.
- LOAD CASE(S)** Standard



June 4, 2024

WARNING - Verify design parameters and READ NOTES ON THIS AND INCLUDED MITEK REFERENCE PAGE MII-7473 rev. 1/2/2023 BEFORE USE.

Design valid for use only with MiTek® connectors. This design is based only upon parameters shown, and is for an individual building component, not a truss system. Before use, the building designer must verify the applicability of design parameters and properly incorporate this design into the overall building design. Bracing indicated is to prevent buckling of individual truss web and/or chord members only. Additional temporary and permanent bracing is always required for stability and to prevent collapse with possible personal injury and property damage. For general guidance regarding the fabrication, storage, delivery, erection and bracing of trusses and truss systems, see **ANSI/TPI Quality Criteria and DSB-22** available from Truss Plate Institute (www.tpinst.org) and **BCSI Building Component Safety Information** available from the Structural Building Component Association (www.sbcacomponents.com)



818 Soundside Road
Edenton, NC 27932

| | | | | | | |
|-----------------|--------------|----------------------|----------|----------|--|-----------|
| Job 24070189 | Truss B02 | Truss Type Common | Qty 2 | Ply 1 | 43 Mason Ridge-Roof-Cali M VMB GRH Job Reference (optional) | 165976677 |
|-----------------|--------------|----------------------|----------|----------|--|-----------|

Carter Components (Sanford, NC), Sanford, NC - 27332,

Run: 8.73 S Apr 25 2024 Print: 8.730 S Apr 25 2024 MiTek Industries, Inc. Mon Jun 03 09:40:54
ID:0HizdM6Q_VVmmaATcnVXKBzwikh-RfC?PsB70Hq3NSgPqnL8w3uITXbGKWrcDoi7J4zJC7f

Page: 1

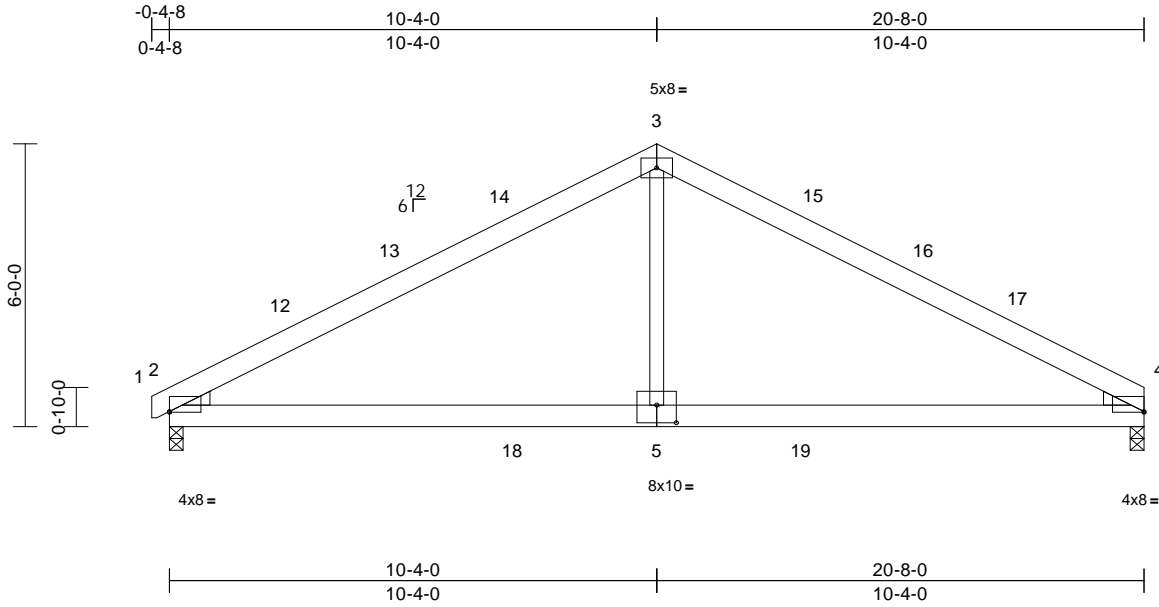

Scale = 1:48.9

Plate Offsets (X, Y): [2:Edge,0-0-3], [4:Edge,0-0-3], [5:0-5-0,0-4-8]

| Loading | (psf) | Spacing | 2-0-0 | CSI | DEFL | in | (loc) | l/defl | L/d | PLATES | GRIP | |
|-------------|-------|-----------------|-----------------|------------|------|----------|-------|--------|------|--------|----------------|----------|
| TCLL (roof) | 20.0 | Plate Grip DOL | 1.15 | TC | 0.89 | Vert(LL) | -0.12 | 5-8 | >999 | 240 | MT20 | 244/190 |
| Snow (Pf) | 20.0 | Lumber DOL | 1.15 | BC | 0.64 | Vert(CT) | -0.19 | 5-8 | >999 | 180 | | |
| TCDL | 10.0 | Rep Stress Incr | YES | WB | 0.22 | Horz(CT) | 0.03 | 2 | n/a | n/a | | |
| BCLL | 0.0* | Code | IRC2018/TPI2014 | Matrix-MSH | | | | | | | | |
| BCDL | 10.0 | | | | | | | | | | | |
| | | | | | | | | | | | Weight: 113 lb | FT = 20% |

LUMBER

TOP CHORD 2x6 SP No.2
 BOT CHORD 2x6 SP No.2
 WEBS 2x4 SP No.3
 WEDGE Left: 2x4 SP No.3
 Right: 2x4 SP No.3

BRACING

TOP CHORD Structural wood sheathing directly applied or 2-2-0 oc purlins.
 BOT CHORD Rigid ceiling directly applied or 10-0-0 oc bracing.

REACTIONS (size) 2=0-3-8, 4=0-3-8

Max Horiz 2=87 (LC 14), 4=79 (LC 15)
 Max Uplift 2=-85 (LC 14), 4=-79 (LC 15)
 Max Grav 2=975 (LC 5), 4=959 (LC 6)

FORCES (lb) - Maximum Compression/Maximum Tension

TOP CHORD 1-2=0/9, 2-3=-1282/221, 3-4=-1282/221
 BOT CHORD 2-4=-233/1037
 WEBS 3-5=0/574

NOTES

- Unbalanced roof live loads have been considered for this design.
- Wind: ASCE 7-16; Vult=130mph (3-second gust)
 Vasd=103mph; TCDL=6.0psf; BCDL=6.0psf; h=25ft; Cat. II; Exp B; Enclosed; MWFRS (envelope) exterior zone and C-C Exterior(2E) -0-3-14 to 2-8-2, Interior (1) 2-8-2 to 7-4-0, Exterior(2R) 7-4-0 to 13-4-0, Interior (1) 13-4-0 to 17-8-0, Exterior(2E) 17-8-0 to 20-8-0 zone; cantilever left and right exposed; end vertical left and right exposed; C-C for members and forces & MWFRS for reactions shown; Lumber DOL=1.60 plate grip DOL=1.60
- TCLL: ASCE 7-16; Pr=20.0 psf (roof LL: Lum DOL=1.15 Plate DOL=1.15); Pf=20.0 psf (Lum DOL=1.15 Plate DOL=1.15); Is=1.0; Rough Cat B; Fully Exp.; Ce=0.9; Cs=1.00; Ct=1.10

- Unbalanced snow loads have been considered for this design.
- This truss has been designed for greater of min roof live load of 12.0 psf or 1.00 times flat roof load of 20.0 psf on overhangs non-concurrent with other live loads.
- This truss has been designed for a 10.0 psf bottom chord live load nonconcurrent with any other live loads.
- * This truss has been designed for a live load of 20.0psf on the bottom chord in all areas where a rectangle 3-06-00 tall by 2-00-00 wide will fit between the bottom chord and any other members, with BCDL = 10.0psf.
- One H2.5A Simpson Strong-Tie connectors recommended to connect truss to bearing walls due to UPLIFT at jt(s) 4 and 2. This connection is for uplift only and does not consider lateral forces.
- This truss is designed in accordance with the 2018 International Residential Code sections R502.11.1 and R802.10.2 and referenced standard ANSI/TPI 1.

LOAD CASE(S) Standard

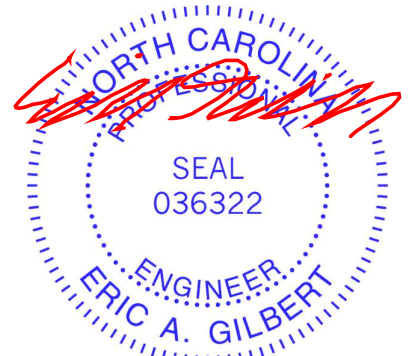

June 4, 2024

WARNING - Verify design parameters and READ NOTES ON THIS AND INCLUDED MITEK REFERENCE PAGE MII-7473 rev. 1/2/2023 BEFORE USE.

Design valid for use only with MiTek® connectors. This design is based only upon parameters shown, and is for an individual building component, not a truss system. Before use, the building designer must verify the applicability of design parameters and properly incorporate this design into the overall building design. Bracing indicated is to prevent buckling of individual truss web and/or chord members only. Additional temporary and permanent bracing is always required for stability and to prevent collapse with possible personal injury and property damage. For general guidance regarding the fabrication, storage, delivery, erection and bracing of trusses and truss systems, see **ANSI/TP1 Quality Criteria and DSB-22** available from Truss Plate Institute (www.tpinst.org) and **BCSI Building Component Safety Information** available from the Structural Building Component Association (www.sbcacomponents.com)



818 Soundside Road
 Edenton, NC 27932

| | | | | | | |
|-----------------|--------------|--------------------------------------|----------|----------|--|-----------|
| Job 24070189 | Truss C01 | Truss Type Common Supported Gable | Qty 1 | Ply 1 | 43 Mason Ridge-Roof-Cali M VMB GRH Job Reference (optional) | 165976678 |
|-----------------|--------------|--------------------------------------|----------|----------|--|-----------|

Carter Components (Sanford, NC), Sanford, NC - 27332,

Run: 8.73 S Apr 25 2024 Print: 8.730 S Apr 25 2024 MiTek Industries, Inc. Mon Jun 03 09:40:55
ID:Kw41b4tysUstfYFG9TCDw0tzwios-RfC?PsB70Hq3NSgPqnL8w3uTXbGKwRCDoi7J4zJC?f

Page: 1

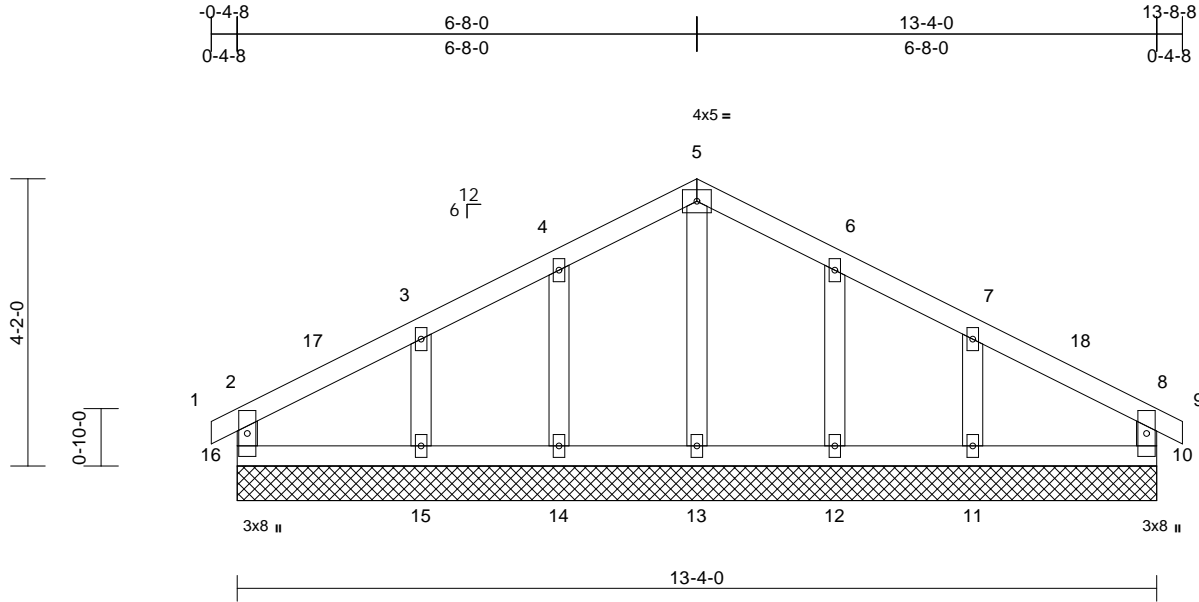

Scale = 1:33.4

| Loading | (psf) | Spacing | 1-11-4 | CSI | DEFL | in | (loc) | l/defl | L/d | PLATES | GRIP | |
|-------------|-------|-----------------|-----------------|-----------|------|----------|-------|--------|-----|--------|---------------|----------|
| TCLL (roof) | 20.0 | Plate Grip DOL | 1.15 | TC | 0.09 | Vert(LL) | n/a | - | n/a | 999 | MT20 | 244/190 |
| Snow (Pf) | 20.0 | Lumber DOL | 1.15 | BC | 0.05 | Vert(CT) | n/a | - | n/a | 999 | | |
| TCDL | 10.0 | Rep Stress Incr | YES | WB | 0.05 | Horz(CT) | 0.00 | 10 | n/a | n/a | | |
| BCLL | 0.0* | Code | IRC2018/TPI2014 | Matrix-MR | | | | | | | | |
| BCDL | 10.0 | | | | | | | | | | | |
| | | | | | | | | | | | Weight: 63 lb | FT = 20% |

LUMBER
TOP CHORD 2x4 SP No.2
BOT CHORD 2x4 SP No.2
WEBS 2x4 SP No.3
OTHERS 2x4 SP No.3

BRACING
TOP CHORD Structural wood sheathing directly applied or 6-0-0 oc purlins, except end verticals.
BOT CHORD Rigid ceiling directly applied or 10-0-0 oc bracing.

REACTIONS (size)
10=13-4-0, 11=13-4-0, 12=13-4-0,
13=13-4-0, 14=13-4-0, 15=13-4-0,
16=13-4-0
Max Horiz 16=59 (LC 13)
Max Uplift 10=20 (LC 14), 11=64 (LC 15),
12=38 (LC 15), 14=38 (LC 14),
15=66 (LC 14), 16=24 (LC 15)
Max Grav 10=143 (LC 22), 11=262 (LC 22),
12=225 (LC 22), 13=127 (LC 22),
14=225 (LC 21), 15=262 (LC 21),
16=143 (LC 21)

FORCES (lb) - Maximum Compression/Maximum Tension
TOP CHORD 2-16=-123/106, 1-2=0/14, 2-3=-70/67,
3-4=-75/140, 4-5=-87/195, 5-6=-87/195,
6-7=-75/140, 7-8=-67/67, 8-9=0/14,
8-10=-123/106
BOT CHORD 15-16=-15/44, 14-15=-15/44, 13-14=-15/44,
12-13=-15/44, 11-12=-15/44, 10-11=-15/44
WEBS 5-13=-89/6, 4-14=-190/99, 3-15=-211/141,
6-12=-190/99, 7-11=-211/141

NOTES
1) Unbalanced roof live loads have been considered for this design.

- Wind: ASCE 7-16; Vult=130mph (3-second gust) Vasd=103mph; TCDL=6.0psf; BCDL=6.0psf; h=25ft; Cat. II; Exp B; Enclosed; MWFRS (envelope) exterior zone and C-C Corner(3E) -0-4-8 to 2-8-0, Exterior(2N) 2-8-0 to 3-8-0, Corner(3R) 3-8-0 to 9-8-0, Exterior(2N) 9-8-0 to 10-8-0, Corner(3E) 10-8-0 to 13-8-8 zone; end vertical left and right exposed; C-C for members and forces & MWFRS for reactions shown; Lumber DOL=1.60 plate grip DOL=1.60
- Truss designed for wind loads in the plane of the truss only. For studs exposed to wind (normal to the face), see Standard Industry Gable End Details as applicable, or consult qualified building designer as per ANSI/TPI 1.
- TCLL: ASCE 7-16; Pr=20.0 psf (roof LL: Lum DOL=1.15 Plate DOL=1.15); Pf=20.0 psf (Lum DOL=1.15 Plate DOL=1.15); Is=1.0; Rough Cat B; Fully Exp.; Ce=0.9; Cs=1.00; Ct=1.10
- Unbalanced snow loads have been considered for this design.
- This truss has been designed for greater of min roof live load of 12.0 psf or 1.00 times flat roof load of 20.0 psf on overhangs non-concurrent with other live loads.
- All plates are 2x4 MT20 unless otherwise indicated.
- Gable requires continuous bottom chord bearing.
- Truss to be fully sheathed from one face or securely braced against lateral movement (i.e. diagonal web).
- Gable studs spaced at 2-0-0 oc.
- This truss has been designed for a 10.0 psf bottom chord live load nonconcurrent with any other live loads.
- * This truss has been designed for a live load of 20.0psf on the bottom chord in all areas where a rectangle 3-06-00 tall by 2-00-00 wide will fit between the bottom chord and any other members.
- Provide mechanical connection (by others) of truss to bearing plate capable of withstanding 24 lb uplift at joint 16, 20 lb uplift at joint 10, 38 lb uplift at joint 14, 66 lb uplift at joint 15, 38 lb uplift at joint 12 and 64 lb uplift at joint 11.

14) This truss is designed in accordance with the 2018 International Residential Code sections R502.11.1 and R802.10.2 and referenced standard ANSI/TPI 1.
LOAD CASE(S) Standard

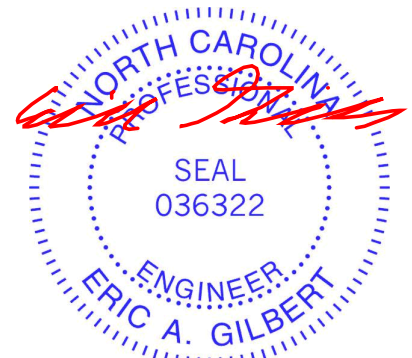

June 4, 2024

WARNING - Verify design parameters and READ NOTES ON THIS AND INCLUDED MITEK REFERENCE PAGE MII-7473 rev. 1/2/2023 BEFORE USE.

Design valid for use only with MiTek® connectors. This design is based only upon parameters shown, and is for an individual building component, not a truss system. Before use, the building designer must verify the applicability of design parameters and properly incorporate this design into the overall building design. Bracing indicated is to prevent buckling of individual truss web and/or chord members only. Additional temporary and permanent bracing is always required for stability and to prevent collapse with possible personal injury and property damage. For general guidance regarding the fabrication, storage, delivery, erection and bracing of trusses and truss systems, see **ANSI/TPI Quality Criteria and DSB-22** available from Truss Plate Institute (www.tpinst.org) and **BCSI Building Component Safety Information** available from the Structural Building Component Association (www.sbcacomponents.com)



818 Soundside Road
Edenton, NC 27932

| | | | | | | |
|-----------------|--------------|----------------------|----------|----------|--|-----------|
| Job 24070189 | Truss C02 | Truss Type Common | Qty 2 | Ply 1 | 43 Mason Ridge-Roof-Cali M VMB GRH Job Reference (optional) | I65976679 |
|-----------------|--------------|----------------------|----------|----------|--|-----------|

Carter Components (Sanford, NC), Sanford, NC - 27332,

Run: 8.73 S Apr 25 2024 Print: 8.730 S Apr 25 2024 MiTek Industries, Inc. Mon Jun 03 09:40:55
ID:d4azmvaKCIAQCTJsNFXM6zwiny-RfC?PsB70Hq3NSgPqnL8w3ulTXbGKWrCDoi7J4zJC?f

Page: 1

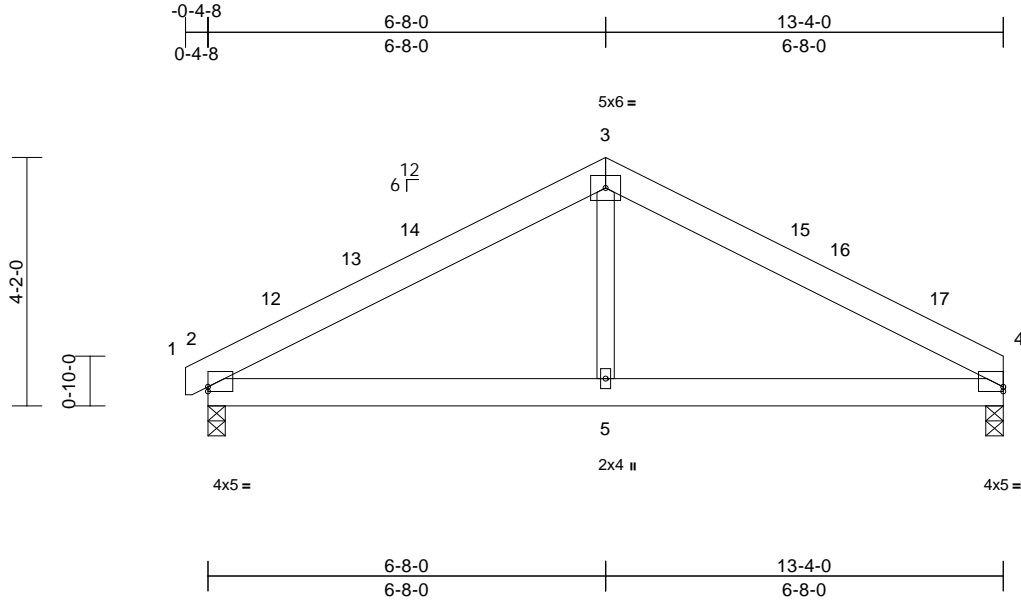

Scale = 1:38.6
Plate Offsets (X, Y): [2:Edge,0-0-15], [4:Edge,0-0-15]

| Loading | (psf) | Spacing | 2-0-0 | CSI | DEFL | in | (loc) | l/defl | L/d | PLATES | GRIP | |
|-------------|-------|-----------------|-----------------|------------|------|----------|-------|--------|------|--------|---------------|----------|
| TCLL (roof) | 20.0 | Plate Grip DOL | 1.15 | TC | 0.35 | Vert(LL) | -0.02 | 5-8 | >999 | 240 | MT20 | 244/190 |
| Snow (Pf) | 20.0 | Lumber DOL | 1.15 | BC | 0.25 | Vert(CT) | -0.04 | 5-8 | >999 | 180 | | |
| TCDL | 10.0 | Rep Stress Incr | YES | WB | 0.11 | Horz(CT) | 0.01 | 2 | n/a | n/a | | |
| BCLL | 0.0* | Code | IRC2018/TPI2014 | Matrix-MSH | | | | | | | | |
| BCDL | 10.0 | | | | | | | | | | | |
| | | | | | | | | | | | Weight: 73 lb | FT = 20% |

LUMBER
TOP CHORD 2x6 SP No.2
BOT CHORD 2x6 SP No.2
WEBS 2x4 SP No.3

BRACING
TOP CHORD Structural wood sheathing directly applied or 6-0-0 oc purlins.
BOT CHORD Rigid ceiling directly applied or 10-0-0 oc bracing.

REACTIONS (size) 2=0-3-8, 4=0-3-8
Max Horiz 2=58 (LC 14)
Max Uplift 2=-56 (LC 14), 4=-50 (LC 15)
Max Grav 2=639 (LC 21), 4=619 (LC 22)

FORCES (lb) - Maximum Compression/Maximum Tension
TOP CHORD 1-2=0/9, 2-3=-761/244, 3-4=-761/244
BOT CHORD 2-5=-132/567, 4-5=-119/567
WEBS 3-5=0/285

- This truss has been designed for greater of min roof live load of 12.0 psf or 1.00 times flat roof load of 20.0 psf on overhangs non-concurrent with other live loads.
- This truss has been designed for a 10.0 psf bottom chord live load nonconcurrent with any other live loads.
- * This truss has been designed for a live load of 20.0psf on the bottom chord in all areas where a rectangle 3-06-00 tall by 2-00-00 wide will fit between the bottom chord and any other members.
- One H2.5A Simpson Strong-Tie connectors recommended to connect truss to bearing walls due to UPLIFT at jt(s) 4 and 2. This connection is for uplift only and does not consider lateral forces.
- This truss is designed in accordance with the 2018 International Residential Code sections R502.11.1 and R802.10.2 and referenced standard ANSI/TPI 1.

LOAD CASE(S) Standard

- NOTES**
- Unbalanced roof live loads have been considered for this design.
 - Wind: ASCE 7-16; Vult=130mph (3-second gust) Vasd=103mph; TCDL=6.0psf; BCDL=6.0psf; h=25ft; Cat. II; Exp B; Enclosed; MWFRS (envelope) exterior zone and C-C Exterior(2E) -0-3-14 to 2-8-2, Interior (1) 2-8-2 to 3-8-0, Exterior(2R) 3-8-0 to 9-8-0, Interior (1) 9-8-0 to 10-4-0, Exterior(2E) 10-4-0 to 13-4-0 zone; cantilever left and right exposed ; end vertical left and right exposed;C-C for members and forces & MWFRS for reactions shown; Lumber DOL=1.60 plate grip DOL=1.60
 - TCLL: ASCE 7-16; Pr=20.0 psf (roof LL: Lum DOL=1.15 Plate DOL=1.15); Pf=20.0 psf (Lum DOL=1.15 Plate DOL=1.15); Is=1.0; Rough Cat B; Fully Exp.; Ce=0.9; Cs=1.00; Ct=1.10
 - Unbalanced snow loads have been considered for this design.

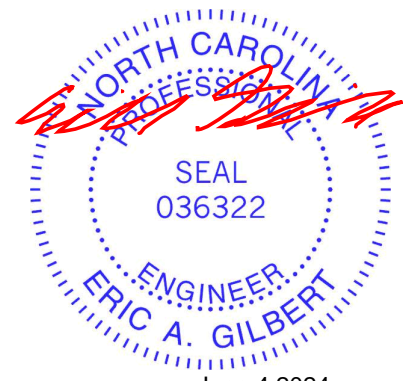

| | | | | | | |
|-----------------|--------------|---------------------------|----------|----------|--|-----------|
| Job 24070189 | Truss D01 | Truss Type Jack-Closed | Qty 3 | Ply 1 | 43 Mason Ridge-Roof-Cali M VMB GRH Job Reference (optional) | 165976680 |
|-----------------|--------------|---------------------------|----------|----------|--|-----------|

Carter Components (Sanford, NC), Sanford, NC - 27332,

Run: 8.73 S Apr 25 2024 Print: 8.730 S Apr 25 2024 MiTek Industries, Inc. Mon Jun 03 09:40:55
ID:gmewhzhvG7_9mXKUwHs9FKOzwiiN-RfC?PsB70Hq3NSgPqnL8w3uITXbGKWrCdoi7J4zJC?f

Page: 1

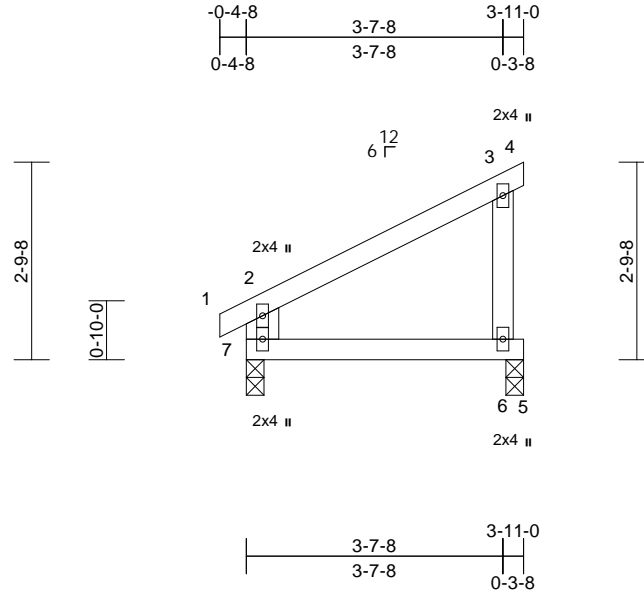

| Loading | (psf) | Spacing | 2-0-0 | CSI | DEFL | in | (loc) | l/defl | L/d | PLATES | GRIP |
|-------------|-------|-----------------|-----------------|------------|------|----------|-------|--------|------|---------------|----------|
| TCLL (roof) | 20.0 | Plate Grip DOL | 1.15 | TC | 0.27 | Vert(LL) | 0.02 | 6-7 | >999 | 240 | 244/190 |
| Snow (Pf) | 20.0 | Lumber DOL | 1.15 | BC | 0.20 | Vert(CT) | 0.02 | 6-7 | >999 | 180 | |
| TCDL | 10.0 | Rep Stress Incr | YES | WB | 0.04 | Horz(CT) | n/a | - | n/a | n/a | |
| BCLL | 0.0* | Code | IRC2018/TPI2014 | Matrix-MSH | | | | | | | |
| BCDL | 10.0 | | | | | | | | | Weight: 17 lb | FT = 20% |

LUMBER
TOP CHORD 2x4 SP No.2
BOT CHORD 2x4 SP No.2
WEBS 2x6 SP No.2 *Except* 3-6:2x4 SP No.3

BRACING
TOP CHORD Structural wood sheathing directly applied or 3-11-0 oc purlins, except end verticals.
BOT CHORD Rigid ceiling directly applied or 10-0-0 oc bracing.

REACTIONS (size) 6=0-3-0, 7=0-3-0
Max Horiz 7=68 (LC 14)
Max Uplift 6=-54 (LC 14), 7=-10 (LC 11)
Max Grav 6=222 (LC 21), 7=252 (LC 21)

FORCES (lb) - Maximum Compression/Maximum Tension
TOP CHORD 2-7=-228/87, 1-2=0/25, 2-3=-77/51, 3-4=-12/0
BOT CHORD 6-7=0/0, 5-6=0/0
WEBS 3-6=-172/123

- 6) * This truss has been designed for a live load of 20.0psf on the bottom chord in all areas where a rectangle 3-06-00 tall by 2-00-00 wide will fit between the bottom chord and any other members.
- 7) Bearings are assumed to be: Joint 7 User Defined , Joint 6 SP No.2 .
- 8) One H2.5A Simpson Strong-Tie connectors recommended to connect truss to bearing walls due to UPLIFT at jt(s) 7 and 6. This connection is for uplift only and does not consider lateral forces.
- 9) This truss is designed in accordance with the 2018 International Residential Code sections R502.11.1 and R802.10.2 and referenced standard ANSI/TPI 1.
- LOAD CASE(S)** Standard

- NOTES**
- 1) Wind: ASCE 7-16; Vult=130mph (3-second gust)
Vasd=103mph; TCDL=6.0psf; BCDL=6.0psf; h=25ft; Cat. II; Exp B; Enclosed; MWFRS (envelope) exterior zone and C-C Exterior(2E) zone; cantilever left and right exposed ; end vertical left exposed; porch left and right exposed;C-C for members and forces & MWFRS for reactions shown; Lumber DOL=1.60 plate grip DOL=1.60
 - 2) TCLL: ASCE 7-16; Pr=20.0 psf (roof LL: Lum DOL=1.15 Plate DOL=1.15); Pf=20.0 psf (Lum DOL=1.15 Plate DOL=1.15); Is=1.0; Rough Cat B; Fully Exp.; Ce=0.9; Cs=1.00; Ct=1.10
 - 3) Unbalanced snow loads have been considered for this design.
 - 4) This truss has been designed for greater of min roof live load of 12.0 psf or 1.00 times flat roof load of 20.0 psf on overhangs non-concurrent with other live loads.
 - 5) This truss has been designed for a 10.0 psf bottom chord live load nonconcurrent with any other live loads.

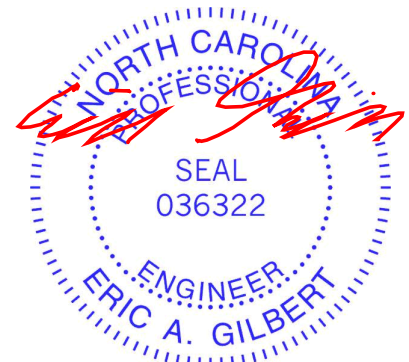

June 4,2024

WARNING - Verify design parameters and READ NOTES ON THIS AND INCLUDED MITEK REFERENCE PAGE MII-7473 rev. 1/2/2023 BEFORE USE.

Design valid for use only with MiTek® connectors. This design is based only upon parameters shown, and is for an individual building component, not a truss system. Before use, the building designer must verify the applicability of design parameters and properly incorporate this design into the overall building design. Bracing indicated is to prevent buckling of individual truss web and/or chord members only. Additional temporary and permanent bracing is always required for stability and to prevent collapse with possible personal injury and property damage. For general guidance regarding the fabrication, storage, delivery, erection and bracing of trusses and truss systems, see **ANSI/TPI Quality Criteria and DSB-22** available from Truss Plate Institute (www.tpinst.org) and **BCSI Building Component Safety Information** available from the Structural Building Component Association (www.sbcacomponents.com)



818 Soundside Road
Edenton, NC 27932

Symbols

PLATE LOCATION AND ORIENTATION

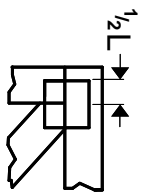

Center plate on joint unless x, y offsets are indicated. Dimensions are in ft-in-sixteenths. Apply plates to both sides of truss and fully embed teeth.

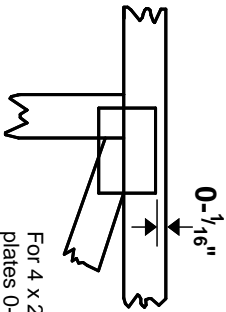

For 4 x 2 orientation, locate plates 0- 1/16\"/>



This symbol indicates the required direction of slots in connector plates.

* Plate location details available in MITek software or upon request.

PLATE SIZE

4 X 4

The first dimension is the plate width measured perpendicular to slots. Second dimension is the length parallel to slots.

LATERAL BRACING LOCATION

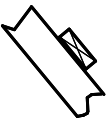

Indicated by symbol shown and/or by text in the bracing section of the output. Use T or I bracing if indicated.

BEARING

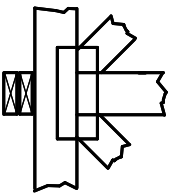

Indicates location where bearings (supports) occur. Icons vary but reaction section indicates joint number/letter where bearings occur. Min size shown is for crushing only.

Industry Standards:

ANSI/TP1: National Design Specification for Metal Plate Connected Wood Truss Construction.
DSB-22: Design Standard for Bracing.
BCSI: Building Component Safety Information, Guide to Good Practice for Handling, Installing, Restraining & Bracing of Metal Plate Connected Wood Trusses.

Numbering System

6-4-8 dimensions shown in ft-in-sixteenths (Drawings not to scale)

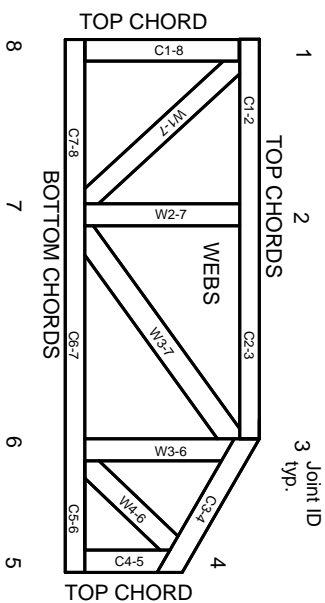

JOINTS ARE GENERALLY NUMBERED/LETTERED CLOCKWISE AROUND THE TRUSS STARTING AT THE JOINT FARTHEST TO THE LEFT.

CHORDS AND WEBS ARE IDENTIFIED BY END JOINT NUMBERS/LETTERS.

Product Code Approvals

ICC-ES Reports:

ESR-1988, ESR-2362, ESR-2685, ESR-3282
ESR-4722, ESL-1388

Design General Notes

Trusses are designed for wind loads in the plane of the truss unless otherwise shown.

Lumber design values are in accordance with ANSI/TP1 section 6.3. These truss designs rely on Lumber values established by others.

© 2023 MITek® All Rights Reserved

General Safety Notes

Failure to Follow Could Cause Property Damage or Personal Injury

1. Additional stability/bracing for truss system, e.g. diagonal or X-bracing, is always required. See BCSI.
2. Truss bracing must be designed by an engineer. For wide truss spacing, individual lateral braces themselves may require bracing, or alternative Tor I bracing should be considered.
3. Never exceed the design loading shown and never stack materials on inadequately braced trusses.
4. Provide copies of this truss design to the building designer, erection supervisor, property owner and all other interested parties.
5. Cut members to bear tightly against each other.
6. Place plates on each face of truss at each joint and embed fully. Knots and wane at joint locations are regulated by ANSI/TP1 1.
7. Design assumes trusses will be suitably protected from the environment in accord with ANSI/TP1 1.
8. Unless otherwise noted, moisture content of lumber shall not exceed 19% at time of fabrication.
9. Unless expressly noted, this design is not applicable for use with fire retardant, preservative treated, or green lumber.
10. Camber is a non-structural consideration and is the responsibility of truss fabricator. General practice is to camber for dead load deflection.
11. Plate type, size, orientation and location dimensions indicated are minimum plating requirements.
12. Lumber used shall be of the species and size, and in all respects, equal to or better than that specified.
13. Top chords must be sheathed or purlins provided at spacing indicated on design.
14. Bottom chords require lateral bracing at 10 ft. spacing, or less, if no ceiling is installed, unless otherwise noted.
15. Connections not shown are the responsibility of others.
16. Do not cut or alter truss member or plate without prior approval of an engineer.
17. Install and load vertically unless indicated otherwise.
18. Use of green or treated lumber may pose unacceptable environmental, health or performance risks. Consult with project engineer before use.
19. Review all portions of this design (front, back, words and pictures) before use. Reviewing pictures alone is not sufficient.
20. Design assumes manufacture in accordance with ANSI/TP1 1 Quality Criteria.
21. The design does not take into account any dynamic or other loads other than those expressly stated.

MITek

ENGINEERING BY
TRENGO
A MITek Affiliate

MITek Engineering Reference Sheet: MIL-7473 rev. 1/2/2023