

REVISION LOG

REVISION:001 DATE: 1/28/2022

1. REWORK OFFICE & OPT BEDROOM 4
2. CREATE OPTION FOR BATH 3
3. REWORK GARAGE OPTIONS.
4. SHOW OPT BEDROOM 5 W/ BATH 3
5. RESIZE KITCHEN ISLAND PER SUNNYSIDE
6. UPDATE BEDROOM 2 TO SHOW 18" CANTILEVER
7. SHIFT FRONT WALL OF OWNER'S SUITE BACK TO ALIGN WITH BONUS ROOM/ BEDROOM 4
8. SHIFT BATH 2 & OWNER'S BATH BACK TO ADD SPACE FOR BATH 2 AND INCREASE BEDROOM CLOSETS TO 25"
9. RESIZE LOFT/BONUS ROOM/BEDROOM 6 DORMER TO 4'-6"
10. WIDEN ELEVATION 'A' FRONT PORCH TO 7'-0"
11. CREATE 1-CAR GARAGE ELEVATION WITH NO OPTIONS ABOVE
12. CREATE TANDEM GARAGE ELEVATION WITHOUT OPTIONS ABOVE
13. CREATE TANDEM GARAGE ELEVATION WITH BONUS ROOM/BEDROOM 6

REVISION:002 DATE: 1/31/2022

1. MADE 1-CAR GARAGE STANDARD
2. MADE BEDROOM 4 OVER GARAGE STANDARD
3. ELIMINATED OPTIONAL ELEVATIONS SHOWING W/ NO 2ND FLOOR OPTIONS OVER 1-CAR GARAGE AND TANDEM GARAGE.
4. UPDATE BEDROOM 5 OPTION TO SHOW PRIVATE ENTRANCE TO BATH 3 AND RELOCATED PANTRY.
5. ADD WATER HEATER
- 6.

REVISION:003 DATE: 2/08/2022

1. ENCLOSE ENTRY AREA FROM GARAGE AND ADD A CASED OPENING
2. SHOW SHOW STORAGE/CUBBIES CLOSET IN CAFE & RE-CENTERED SLIDER ACCORDINGLY.
3. SHOW ALL WINDOWS ON LEFT SIDE OF HOUSE AS OPTIONAL.
4. CHANGE GARAGE DOOR HEIGHT TO 7'
5. RE-CENTER WINDOWS AT FAMILY ROOM & BEDROOM 3 PER CANTILEVERED OFFSET FOR ELEVATIONS A & B
6. RELOCATE WATER HEATER IN TANDEM GARAGE TO WALL ADJACENT TO MAIN HOUSE.
7. CREATE NEW ELEVATIONS C & D PER PHOTOGRAPHS.
- 8.

REVISION:004 DATE: 2/18/2022

1. CONSOLIDATE OPTIONS TO REDUCE SHEETS
2. UPDATE WINDOW LOCATION/CONFIGURATION IN BEDROOM 2 & 3.
3. CHANGE PORCH ROOF PITCHES BACK TO 4:12.
4. CHANGE ROOF OVER BEDROOM 5 TO 5:12
5. REDUCE HALF HIP SIZE FOR ELEVATION C
6. RESIZE STORAGE CLOSET ADJACENT TO PANTRY AND CHANGE DOOR TO 4/0 DBL.
7. CREATE FALSE GABLE IN ELEVATION D TO BREAK UP SPACE BETWEEN WINDOWS.

REVISION:005 DATE: 05/05/2022

1. ADDED ELECTRICAL INFORMATION TO FLOOR PLANS.

REVISION:006 DATE: 06/09/2022

1. ADD AND DIMENSION LOCATION FOR CLEAN OUT ON FOUNDATION PLAN. NOTE ON FLOOR PLAN.
2. ADD WATER SHUT OFF VALVE TO FOUNDATION AND FLOOR PLANS
3. ADD HVAC COMPRESSOR
4. DELETE PANTRY CHASE
5. CHANGE PATIO SIZE TO 12X12
6. CHANGE 3/0X8/8 CO TO A SRO
7. ADD 2X8 WALL AT OFFICE OPTION FOR CLEANOUT, FLIP DOOR SWING AND RELOCATE SWITCH.
8. CHANGE OWNER'S BATH LINEN DEPTH FROM 1'-8 1/2" TO 1'-10"
9. DIMENSION SINK AT BATH #2
10. SEPARATE TWIN 3/0X5/0 @ OWNERS SUITE

REVISION:007 DATE: 07/22/2022

1. ADD STEM WALL SLAB FOUNDATION SHEETS

Redlines completed 23-May - DP

Lot 137 - Duncan's Creek

102 Plainfield Lane
Lillington, NC 27546

Trademark



Wilson - RH ELEVATION 'C'

ARCHITECTURAL DRAWINGS

Sheet No.	Sheet Description
0.0	Cover Sheet
1.2	Foundation (Slab)
1.3	Foundation (Stem Wall Slab)
2.1	First Floor Plan
2.2	Second Floor Plan
3.1	Front & Left Elevations (Slab)
3.1.1	Front & Left Elevations (Stem Wall)
3.2	Rear & Right Elevations (Slab)
3.2.1	Rear & Right Elevations (Stem Wall)
3.3	Optional Elevations (Slab)
3.3.1	Optional Elevations (Stem Wall)
3.4	Roof Plan
4.0	Building Sections
5.1	First Floor Electrical Plan
5.2	Second Floor Electrical Plan

DESIGN CRITERIA:

THIS PLAN IS TO BE BUILT IN CONFORMANCE WITH THE
2018 NORTH CAROLINA STATE BUILDING CODE: RESIDENTIAL CODE

DIMENSIONS SHALL GOVERN OVER SCALE, AND CODE SHALL
GOVERN OVER DIMENSIONS.

	ELEVATION 'C'	
	UNHEATED	HEATED
FIRST FLOOR	0	828
SECOND FLOOR	0	1036
FRONT PORCH	115	0
PATIO	139	0
1-CAR GARAGE	260	0
SUBTOTALS	514	1864
TOTAL UNDER ROOF	2378	

	OPTIONS	
	UNHEATED S.F.	HEATED S.F.
TANDEM GARAGE	442	0
BEDROOM 5	0	106
BEDROOM 4	0	102



REV.#	DESCRIPTION	DATE
1	SEE COVER SHEET	01/28/22
2	SEE COVER SHEET	01/31/22
3	SEE COVER SHEET	02/08/22
4	SEE COVER SHEET	02/18/22
5	SEE COVER SHEET	05/05/22
6	SEE COVER SHEET	06/09/22
7	SEE COVER SHEET	07/22/22
8		

WILSON - RH

Cover Sheet 'C'

DRAWN BY:
South Designs
ISSUE DATE:
01/14/2022
CURRENT REVISION DATE:

SCALE:
1/8" = 1'-0"

SHEET
0.0c

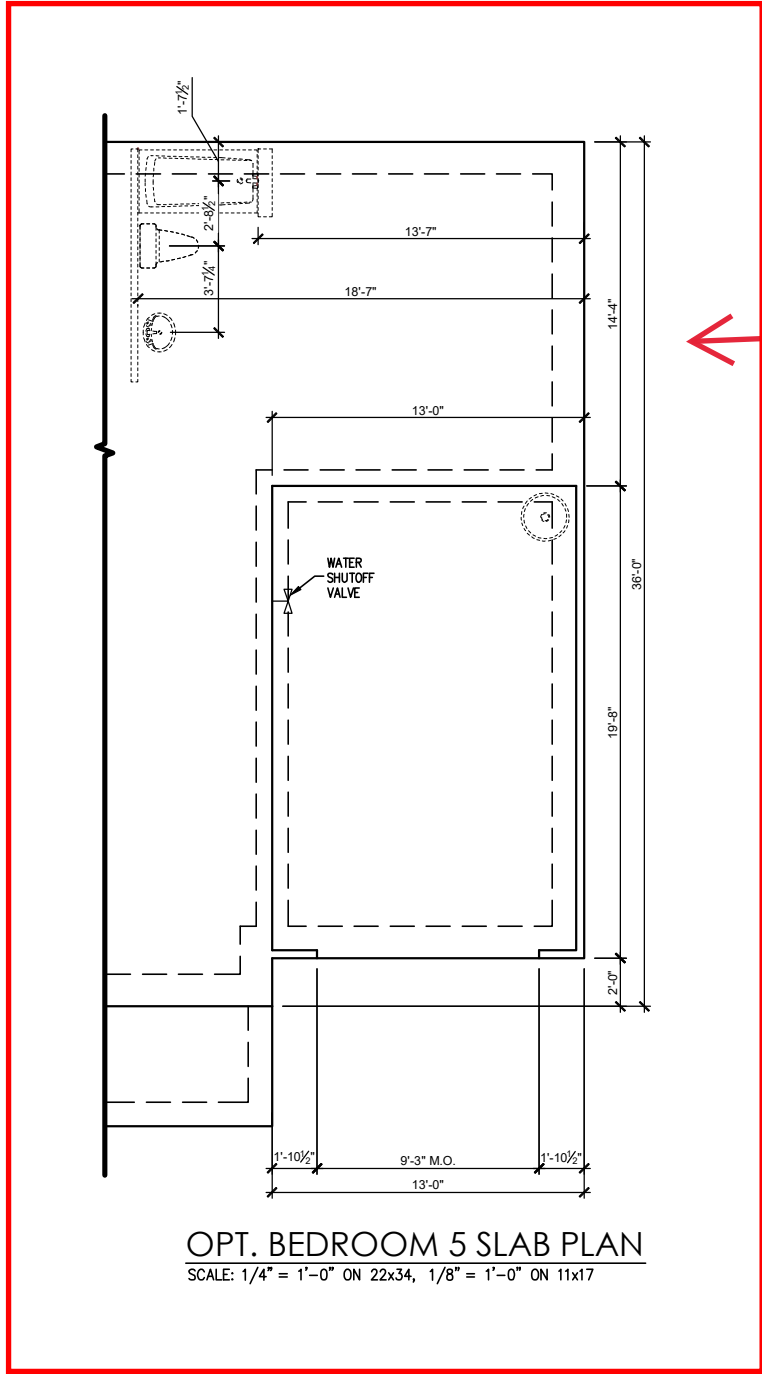

OPT. BEDROOM 5 SLAB PLAN
SCALE: 1/4" = 1'-0" ON 22x34, 1/8" = 1'-0" ON 11x17

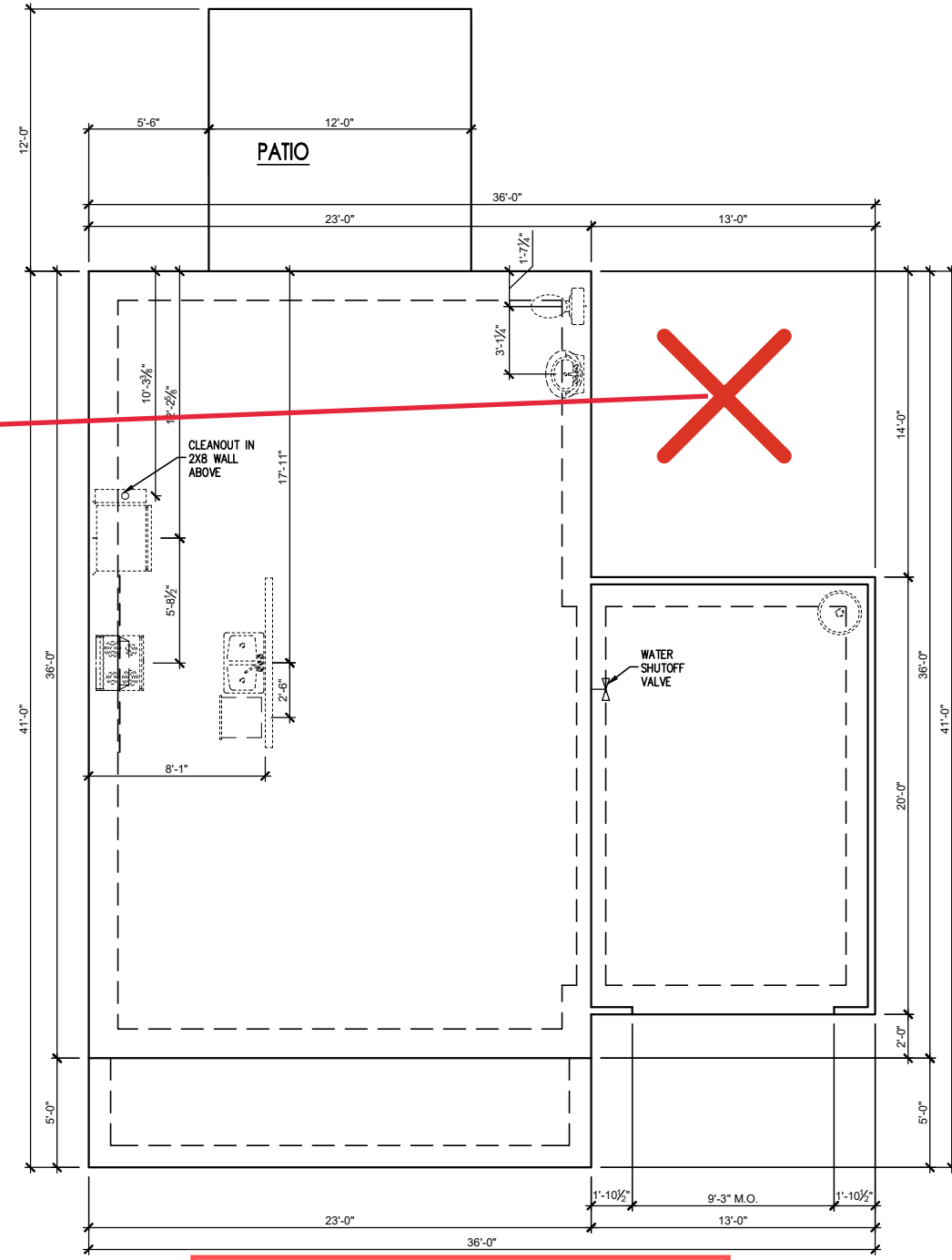

SLAB FOUNDATION ELEVATION 'C'
SCALE: 1/4" = 1'-0" ON 22x34, 1/8" = 1'-0" ON 11x17

REV.#	DESCRIPTION	DATE
1	SEE COVERSHEET	01/28/22
2	SEE COVERSHEET	01/31/22
3	SEE COVERSHEET	02/08/22
4	SEE COVERSHEET	02/18/22
5	SEE COVERSHEET	05/05/22
6	SEE COVERSHEET	06/09/22
7	SEE COVERSHEET	07/22/22
8		

WILSON - RH

Slab Foundation 'C'

DRAWN BY:
South Designs
ISSUE DATE:
01/14/2022
CURRENT REVISION DATE:
—
SCALE:
1/8" = 1'-0"
SHEET
1.2c

General Floor Plan Notes

General Floor Plan Notes shall apply unless noted otherwise on plan.

1. Wall Heights: Typically 9'-0" at first floor, 8'-0" at second floor. All walls are constructed using a double top plate. Splices at Double Top Plate do not need to occur at Vertical Studs but must be at least 24" apart from Joint in other Top Plate layer. Special wall heights are noted on plans where they occur.
2. Wall Thickness is typically 3 1/2". 2x6 frame shall be used at walls that back up to plumbing fixtures. Walls greater than 10' high shall be framed with 2x4 framing or greater and will be noted as a special condition where it occurs on plan.
3. Typical header height shall be 6'-11" AFF at First Floor, and 6'-11" AFF at Second Floor U.N.O.
4. Jacks: Openings up to 3'-4" wide shall have (1) 2x4 jack stud SPF on each side. Openings greater than 3'-4" wide shall have (2) 2x4 jack studs SPF on each side.
5. Soffits: Coffered Ceilings, Tray Ceilings and other significant ceiling plan elements are shown on the floor plans and are denoted as single dashed lines. Unless specifically call out as included, Kitchens do not include soffits over wall cabinetry.
6. Door & Window Frames, where occurring near corners, shall be a minimum of 4 1/2" from corner. Except for walk-in closets with doors near a corner, doors at closets shall be centered on closet.
7. Windows: Shall have at least (1) window in each sleeping room, that meets egress. Shall be provided with tempered glass at hazardous glazing areas. False windows shall be installed with obscure glazing.
8. Closets for clothing or coat storage shall be equipped with 1 rod/shelf. Closets for linen shall have 4 open equal shelves. Closets for pantries shall have 4 equal wood shelves, painted.
9. Stair treads shall be a min of 9" deep, risers shall be a maximum of 8 1/4", unless noted otherwise, per the current North Carolina Residential Code
10. Handrails and Guards at stairs shall be 34" above the finished surface of the ramp surface of the stair. Handrails at landings and overlooks of multilevel spaces shall be 36" above finished floor. Guards (pickets or balusters) shall be spaced with no more than 4" between guards.
11. Attic Access shall be provided at all attic area with a height greater than 30". Minimum clear attic access shall be 20" x 30". Pull down stairs and access doors in knee walls meeting minimum criteria are also acceptable.
12. Garage Door to Living Space shall be 2'-8" x 6'-8" minimum size and shall be 20 minute fire rated and weather sealed.
13. Garage Walls, as a minimum, shall be separated from living space by installing 1/2" gypsum board on the garage side of the wall. With habitable space above, the inside of all garage walls require 1/2" GWB supporting 5/8" type X GWB on ceiling.

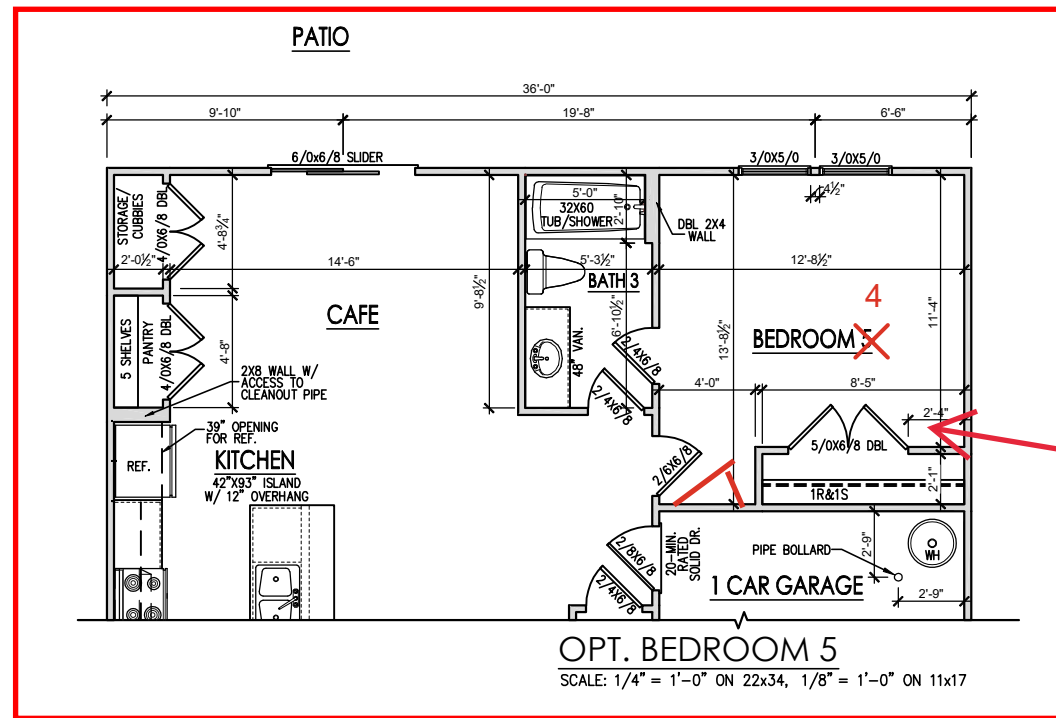

Add (2) 3/0x5/0 Windows in Family

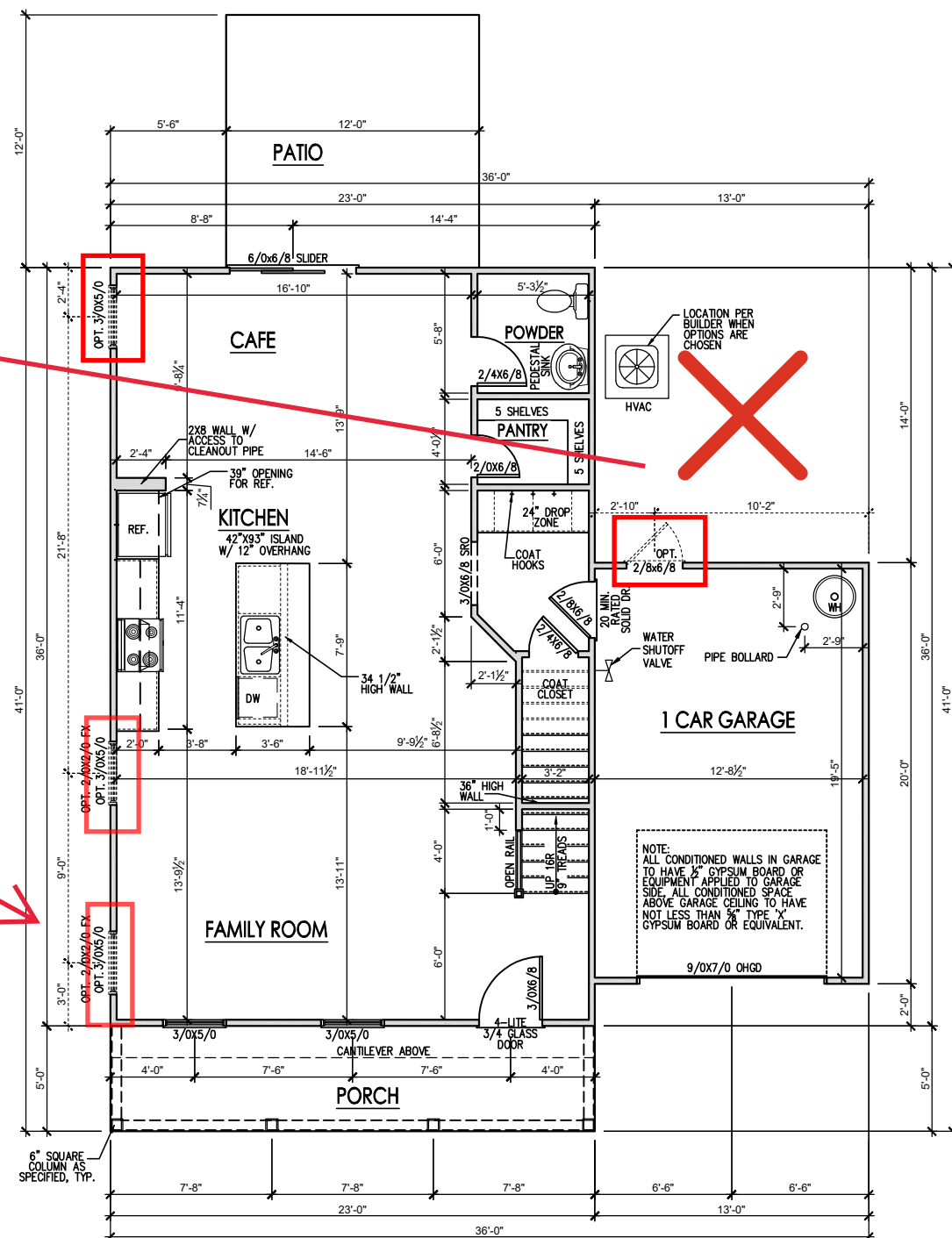

FIRST FLOOR - ELEVATION 'C'
SCALE: 1/4" = 1'-0" ON 22x34, 1/8" = 1'-0" ON 11x17



REV.#	DESCRIPTION	DATE
1	SEE COVERSHEET	01/28/22
2	SEE COVERSHEET	01/31/22
3	SEE COVERSHEET	02/08/22
4	SEE COVERSHEET	02/18/22
5	SEE COVERSHEET	05/05/22
6	SEE COVERSHEET	06/09/22
7	SEE COVERSHEET	07/22/22
8		

WILSON - RH

First Floor Plan 'C'

DRAWN BY: South Designs
ISSUE DATE: 01/14/2022
CURRENT REVISION DATE: ---
SCALE: 1/8" = 1'-0"
SHEET 2.1c

General Floor Plan Notes

General Floor Plan Notes shall apply unless noted otherwise on plan.

1. Wall Heights: Typically 9'-0" at first floor, 8'-0" at second floor. All walls are constructed using a double top plate. Splices at Double Top Plate do not need to occur at Vertical Studs but must be at least 24" apart from Joint in other Top Plate layer. Special wall heights are noted on plans where they occur.
2. Wall Thickness is typically 3 1/2". 2x6 frame shall be used at walls that back up to plumbing fixtures. Walls greater than 10' high shall be framed with 2x6 framing or greater and will be noted as a special condition where it occurs on plan.
3. Typical header height shall be 4'-11" AFF at First Floor, and 4'-11" AFF at Second Floor U.N.O.
4. Jacks: Openings up to 3'-4" wide shall have (1) 2x4 jack stud SPF on each side. Openings greater than 3'-4" wide shall have (2) 2x4 jack studs SPF on each side.
5. Soffits, Coffered Ceilings, Trey Ceilings and other significant ceiling plan elements are shown on the floor plans and are denoted as single dashed lines. Unless specifically call out as included, Kitchens do not include soffits over wall cabinetry.
6. Door & Window Frames, where occurring near corners, shall be a minimum of 4 1/2" from corner. Except for walk-in closets with doors near a corner, doors at closets shall be centered on closet.
7. Windows: Shall have at least (1) window in each sleeping room, that meets egress. Shall be provided with tempered glass at hazardous glazing areas. False windows shall be installed with obscure glazing.
8. Closets for clothing or coat storage shall be equipped with 1 rod/shelf. Closets for linen shall have 4 open equal shelves. Closets for pantries shall have 4 equal wood shelves, painted.
9. Stair treads shall be a min of 9" deep, risers shall be a maximum of 8 1/4", unless noted otherwise, per the current North Carolina Residential Code
10. Handrails and Guards of stairs shall be 34" above the finished surface of the ramp surface of the stair. Handrails at landings and overlooks of multilevel spaces shall be 34" above finished floor. Guards (pickets or balusters) shall be spaced with no more than 4" between guards.
11. Attic Access shall be provided at all attic area with a height greater than 30". Minimum clear attic access shall be 20" x 30". Pull down stairs and access doors in knee walls meeting minimum criteria are also acceptable.
12. Garage Door to Living Space shall be 2'-8" x 4'-8" minimum size and shall be 20 minute fire rated and weather sealed.
13. Garage Walls, as a minimum, shall be separated from living space by installing 1/2" gypsum board on the garage side of the wall. With habitable space above, the inside of all garage walls require 1/2" GWB supporting 5/8" type X GWB on ceiling.

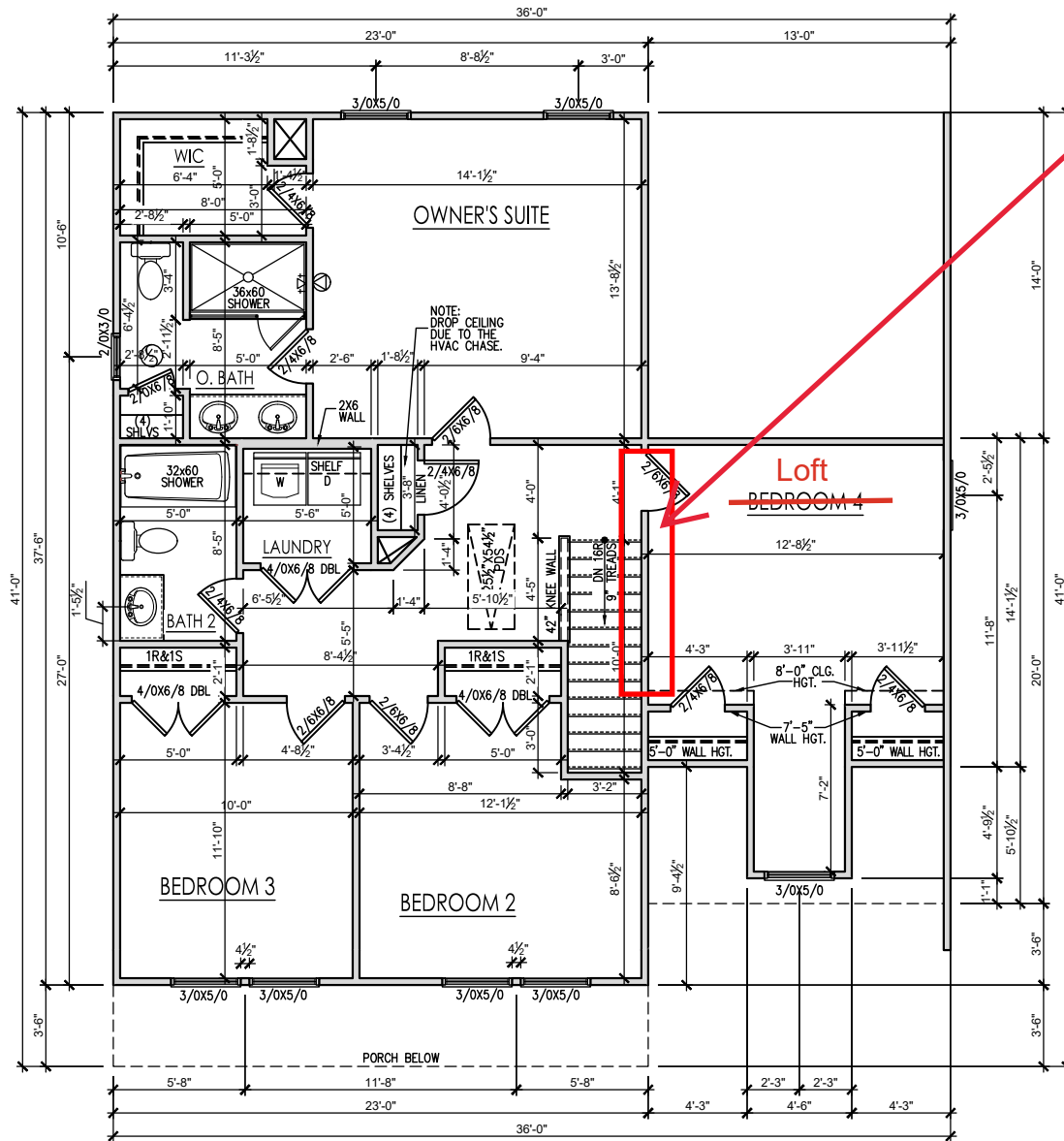

Remove wall and door. Build Kneewall between stairs and Bed 4 down to closet.

SECOND FLOOR ELEVATION 'C'
SCALE: 1/4" = 1'-0" ON 22x34, 1/8" = 1'-0" ON 11x17

REV. #	DESCRIPTION	DATE
1		
2		
3		
4		
5		
6		
7		
8		

General Elevation Notes

General Elevation Notes shall apply unless noted otherwise on plan.

- Roof shall be finished with architectural composition shingles with slopes as noted on plan.
- Ridge Vent shall be provided and installed on all ridges greater than 6' in length per manufacturer's specifications.
- Soffit Vent shall be continuous soffit vent
- House Wrap, "Tyvek" or approved equal shall be installed over entire exterior wall per manufacturer's specifications and recommendations.
- Flashing shall be provided above all door and window openings, above finish wall material changes and at wall surfaces where lower roof areas abut vertical wall surfaces.
- Porch Railings shall be provided at all porch walking surfaces greater than 30" above adjacent finished grade. It shall be 36" high with guards spaced no more than 4" apart. Consult community specifications for material.
- Finish Wall Material shall be as noted on elevation drawings.
- Brick Veneer, if included on elevation shall be tied to wall surface with galvanized corrugated metal ties at a rate of 24" oc horizontally and 16" oc vertically so that no more than 2.67sf of brick is supported by (1) tie. Space between face of wall and back face of brick shall be limited to a maximum of 1". Flashing shall be provided behind brick above all wall openings and at base of brick wall. Flashing shall be a minimum of 6-mil poly or other corrosion resistant material and shall be installed so that it laps under the house wrap material a minimum of 2". Weepholes shall be provided at a rate of 48" oc and shall not be less than 3/16" in diameter and shall be located immediately above flashing.
- Brick Veneer Support Lintels shall be provided if brick veneer is included on elevation. Lintels shall be provided as listed in the following schedule and shall have a minimum bearing length of 6". Masonry Lintels shall be provided so that deflection is limited to L/600.

Masonry Opening Lintel Schedule

Opening Size	Angle
up to 4'-0"	3-1/2" x 3-1/2" x 5/16"
4'-1" to 5'-6"	4" x 3-1/2" x 5/16" LLV
5'-7" to 6'-4"	5" x 3-1/2" x 5/16" LLV
6'-7" to 8'-4"	6" x 3-1/2" x 5/16" LLV
8'-5" to 16'-4"	7" x 4" x 3/8" LLV

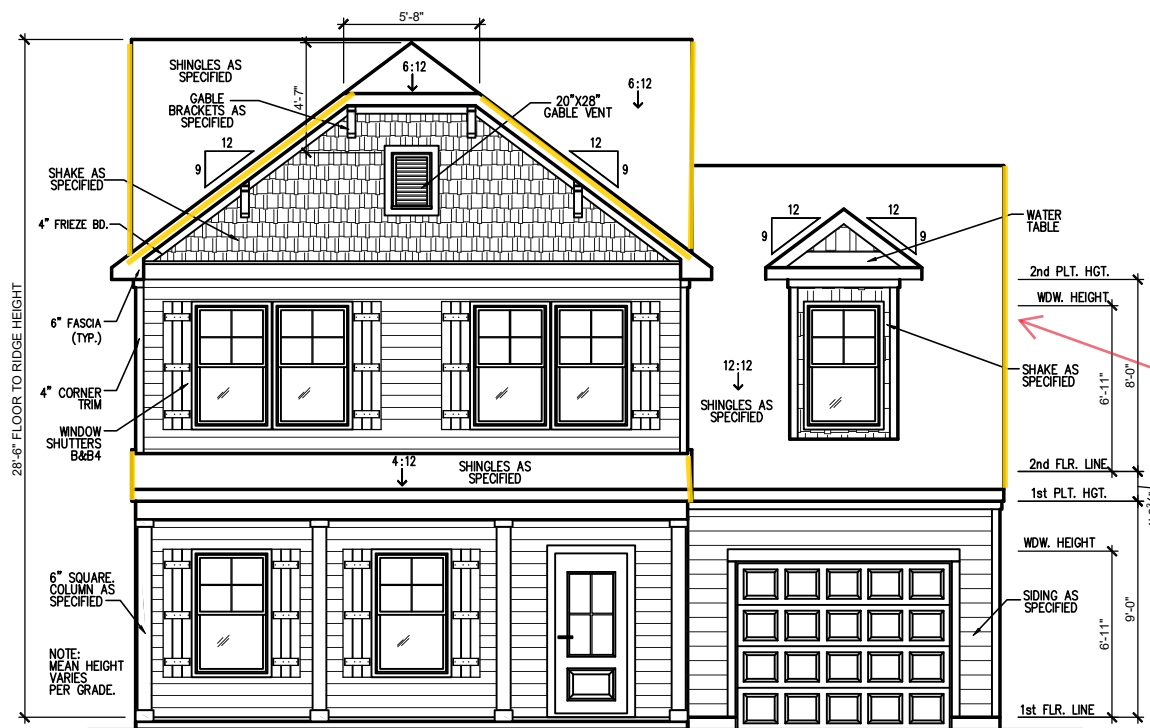

FRONT ELEVATION - 'C' (SLAB)

SCALE: 1/4" = 1'-0" ON 22x34, 1/8" = 1'-0" ON 11x17

12 inch OVERHANGS

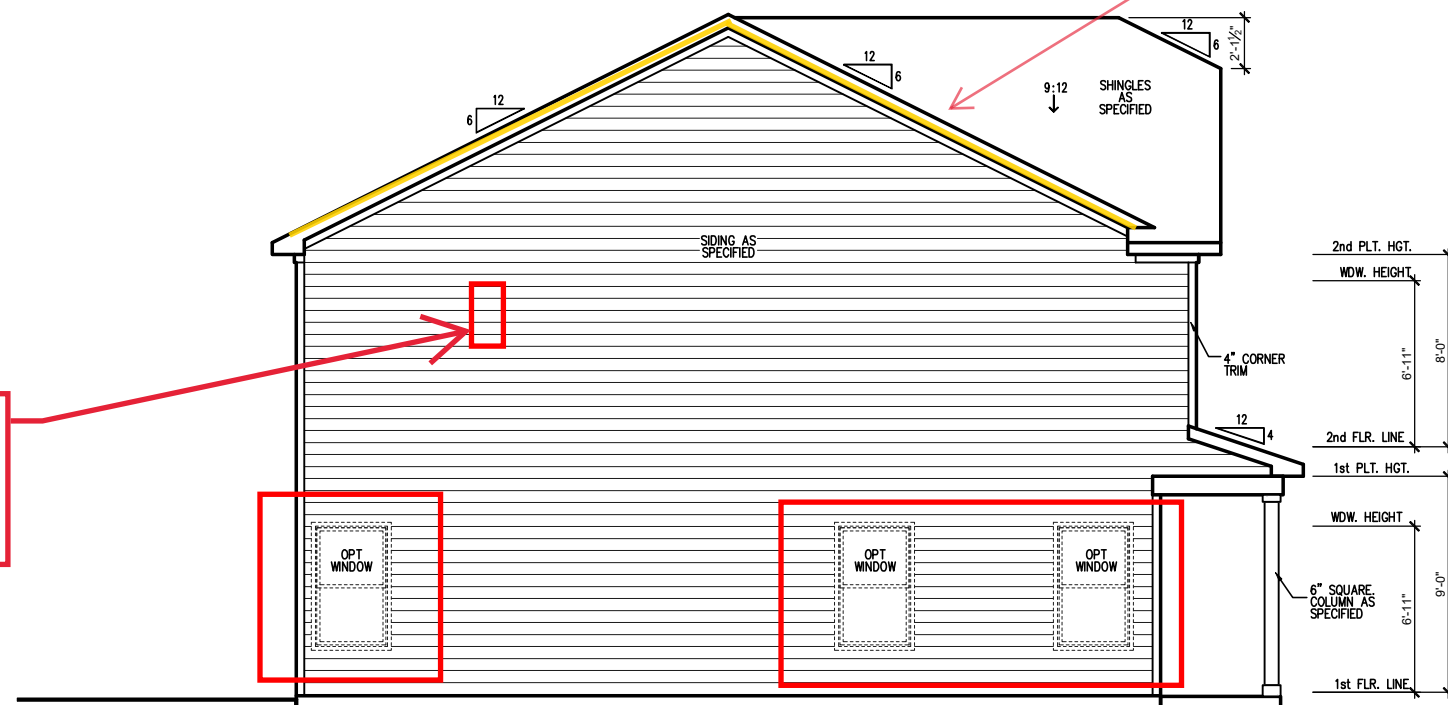

Add 2/0 x 3/0 Window to Owner's Bathroom 10'-3 1/2" from ext rear corner to centerline of window

LEFT SIDE ELEVATION 'C' (SLAB)

SCALE: 1/4" = 1'-0" ON 22x34, 1/8" = 1'-0" ON 11x17

REV.#	DESCRIPTION	DATE
1	SEE COVERSHEET	01/28/22
2	SEE COVERSHEET	01/31/22
3	SEE COVERSHEET	02/08/22
4	SEE COVERSHEET	02/18/22
5	SEE COVERSHEET	05/05/22
6	SEE COVERSHEET	06/09/22
7	SEE COVERSHEET	07/22/22
8		

DRAWN BY:
South Designs

ISSUE DATE:
01/14/2022

CURRENT REVISION DATE:

SCALE:
1/8" = 1'-0"

SHEET

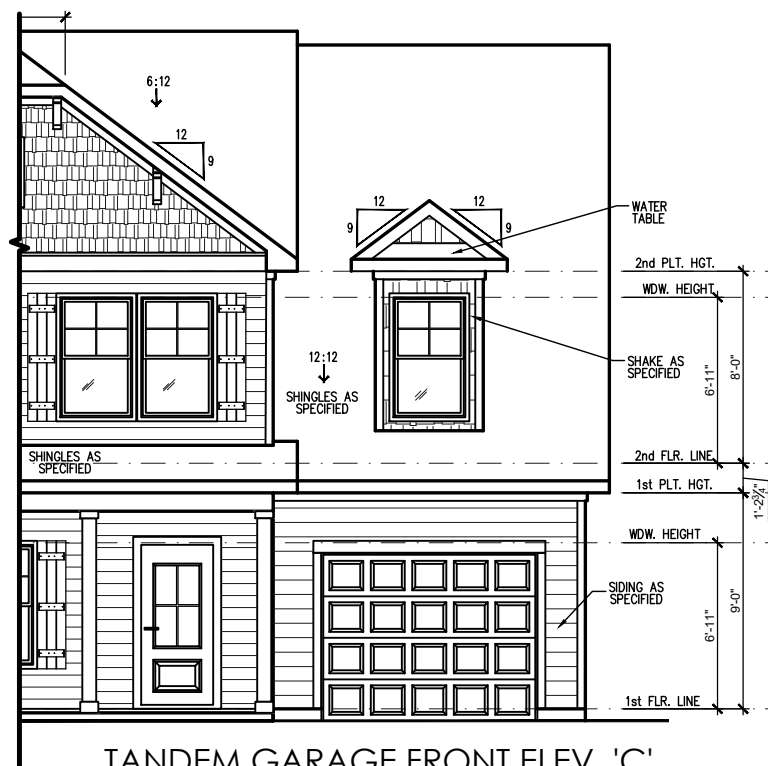

TANDEM GARAGE FRONT ELEV. 'C'
W/ LOFT/ BEDROOM 5 & 6 (SLAB)
SCALE: 1/4" = 1'-0" ON 22x34, 1/8" = 1'-0" ON 11x17

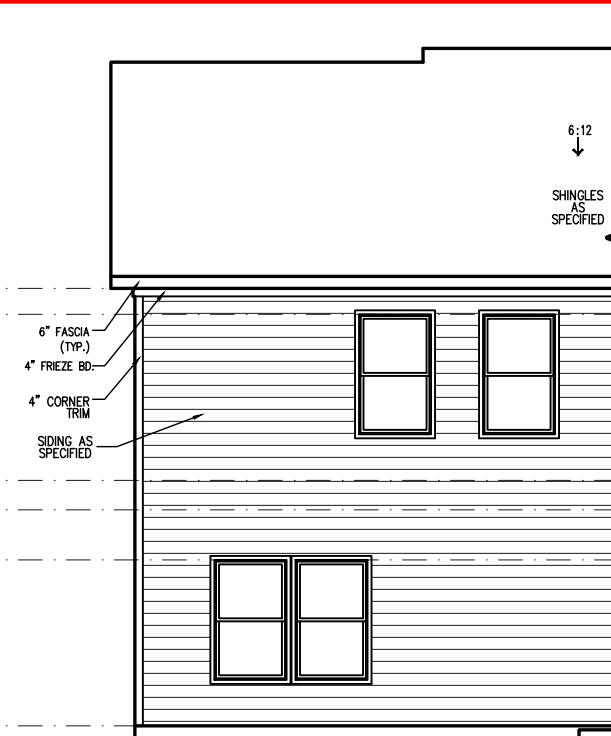

TANDEM GARAGE REAR ELEV
W/ LOFT/ BEDROOM 5 & 6 (SLAB)
SCALE: 1/4" = 1'-0" ON 22x34, 1/8" = 1'-0" ON 11x17

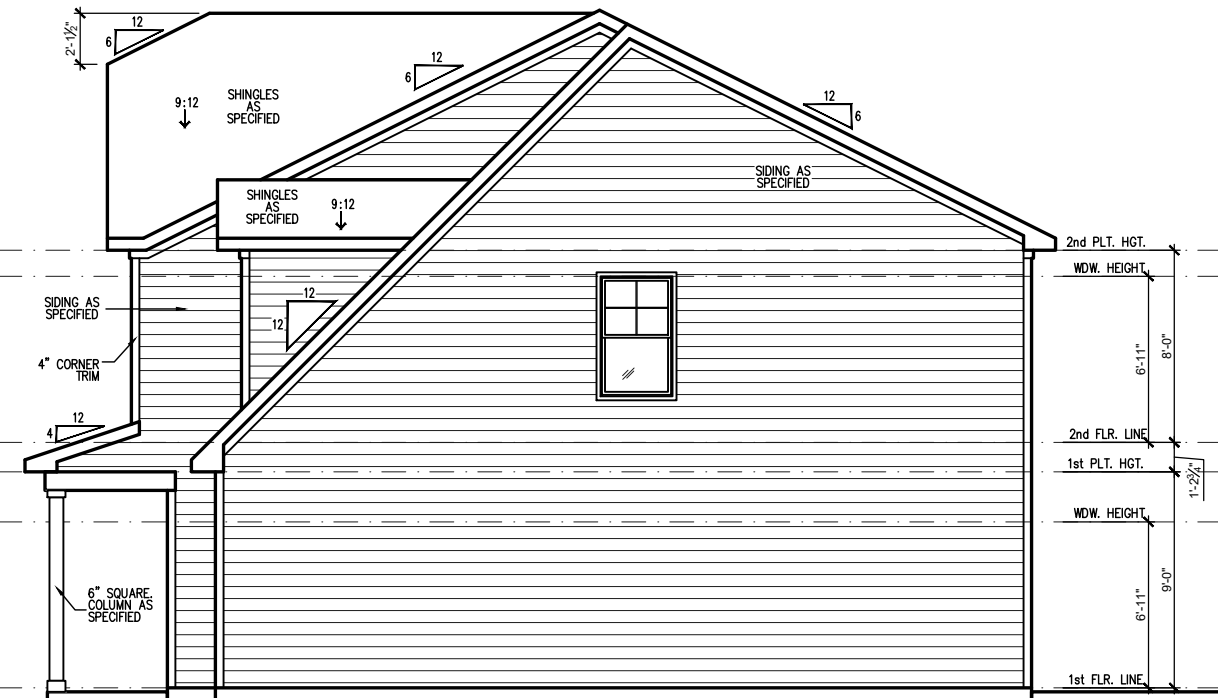

TANDEM GARAGE RIGHT ELEV. 'C'
W/ LOFT/ BEDROOM 5 & 6 (SLAB)
SCALE: 1/4" = 1'-0" ON 22x34, 1/8" = 1'-0" ON 11x17

REV. #	DESCRIPTION	DATE
1		
2		
3		
4		
5		
6		
7		
8		

WILSON
Tandem Garage & Bedroom 5 & 6
Elevations (Slab)

DRAWN BY:
South Designs

ISSUE DATE:
7/1/2021

CURRENT REVISION DATE:

SCALE:
1/8" = 1'-0"

SHEET
3.3c

ATTIC VENT SCHEDULE									
TANDEM GARAGE ROOF									
MAIN HOUSE		SQ FTG		442		AT / NEAR RIDGE		AT / NEAR EAVE	
VENT TYPE	SQ. FT. REQUIRED RANGE	SQ. FT. SUPPLIED	PERCENT OF TOTAL SUPPLIED	POT LARGE (SQ. FT. EACH)	POT SMALL (SQ. FT. EACH)	RIDGE VENT (SQ. FT. PER LF)	EAVE VENT (SQ. IN. EACH)	CONT. VENT (SQ. IN. PER LF)	
RIDGE VENT	0.59	0.74	0.75	44.44	0	0	6.00		
SOFFIT VENTS	0.88	0.74	0.94	55.56			0	15.00	
TOTAL (MIN)	1.47	1.47	1.69	100.00	POT VENTS MAY BE REQUIRED IF THERE IS INSUFFICIENT RIDGE AVAILABLE				

* SCHEDULE HAS BEEN CALCULATED ASSUMING EAVE VENTILATION AT 50-60% OF TOTAL AND RIDGE AT 40-50% OF TOTAL REQUIRED VENTILATION

ATTIC VENT SCHEDULE									
GARAGE ROOF									
MAIN HOUSE		SQ FTG		260		AT / NEAR RIDGE		AT / NEAR EAVE	
VENT TYPE	SQ. FT. REQUIRED RANGE	SQ. FT. SUPPLIED	PERCENT OF TOTAL SUPPLIED	POT LARGE (SQ. FT. EACH)	POT SMALL (SQ. FT. EACH)	RIDGE VENT (SQ. FT. PER LF)	EAVE VENT (SQ. IN. EACH)	CONT. VENT (SQ. IN. PER LF)	
RIDGE VENT	0.35	0.43	0.75	44.44	0	0	6.00		
SOFFIT VENTS	0.52	0.43	0.94	55.56			0	15.00	
TOTAL (MIN)	0.87	0.87	1.69	100.00	POT VENTS MAY BE REQUIRED IF THERE IS INSUFFICIENT RIDGE AVAILABLE				

* SCHEDULE HAS BEEN CALCULATED ASSUMING EAVE VENTILATION AT 50-60% OF TOTAL AND RIDGE AT 40-50% OF TOTAL REQUIRED VENTILATION

ATTIC VENT SCHEDULE									
MAIN ROOF									
MAIN HOUSE		SQ FTG		849		AT / NEAR RIDGE		AT / NEAR EAVE	
VENT TYPE	SQ. FT. REQUIRED RANGE	SQ. FT. SUPPLIED	PERCENT OF TOTAL SUPPLIED	POT LARGE (SQ. FT. EACH)	POT SMALL (SQ. FT. EACH)	RIDGE VENT (SQ. FT. PER LF)	EAVE VENT (SQ. IN. EACH)	CONT. VENT (SQ. IN. PER LF)	
RIDGE VENT	1.13	1.42	1.50	46.15	0	0	12.00		
SOFFIT VENTS	1.70	1.42	1.75	53.85			0	28.00	
TOTAL (MIN)	2.83	2.83	3.25	100.00	POT VENTS MAY BE REQUIRED IF THERE IS INSUFFICIENT RIDGE AVAILABLE				

* SCHEDULE HAS BEEN CALCULATED ASSUMING EAVE VENTILATION AT 50-60% OF TOTAL AND RIDGE AT 40-50% OF TOTAL REQUIRED VENTILATION

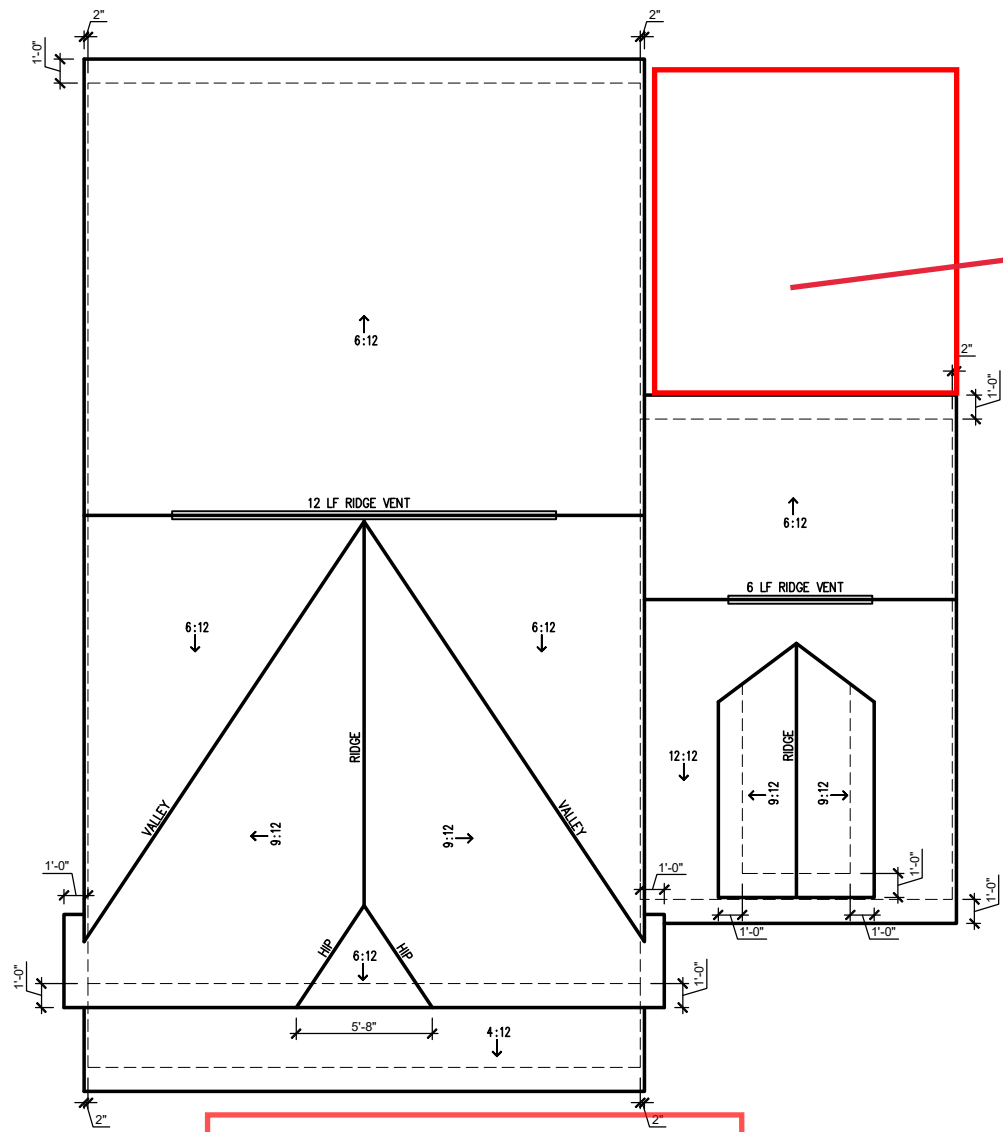

ROOF PLAN ELEVATION - 'C'
SCALE: 1/4" = 1'-0" ON 22x34, 1/8" = 1'-0" ON 11x17

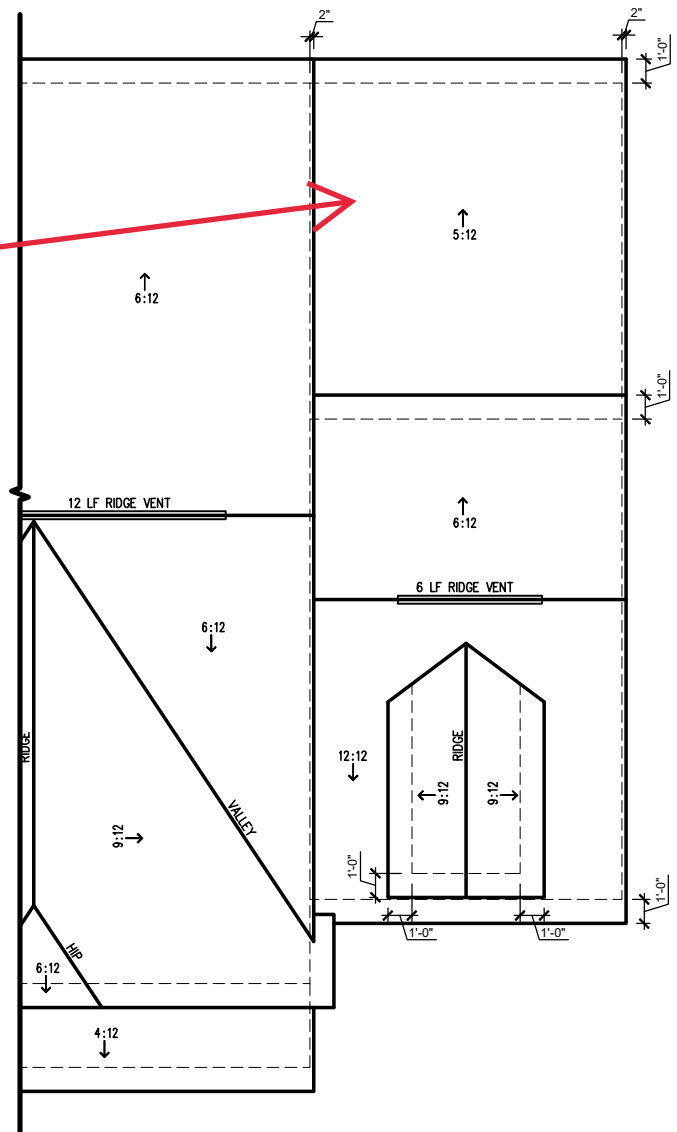

TANDEM GARAGE ROOF PLAN 'C' W/ BEDROOM 5
SCALE: 1/4" = 1'-0" ON 22x34, 1/8" = 1'-0" ON 11x17



REV.#	DESCRIPTION	DATE
1	SEE COVERSHEET	01/28/22
2	SEE COVERSHEET	01/31/22
3	SEE COVERSHEET	02/08/22
4	SEE COVERSHEET	02/18/22
5	SEE COVERSHEET	05/05/22
6	SEE COVERSHEET	06/09/22
7	SEE COVERSHEET	07/22/22
8		

WILSON - RH

Roof Plan 'C'

DRAWN BY: South Designs
ISSUE DATE: 01/14/2022
CURRENT REVISION DATE: ---
SCALE: 1/8" = 1'-0"
SHEET 3.4c

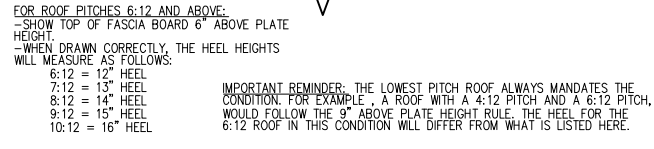
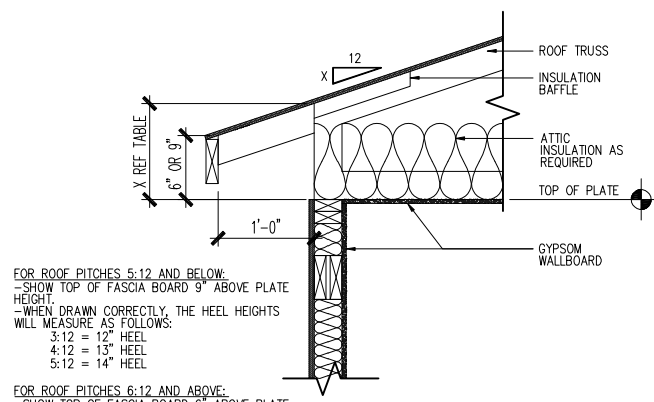

ENERGY HEEL DETAIL: CZ 4 & 5
 SCALE: 1" = 1'-0" ON 22x34, 1/2" = 1'-0" ON 11x17

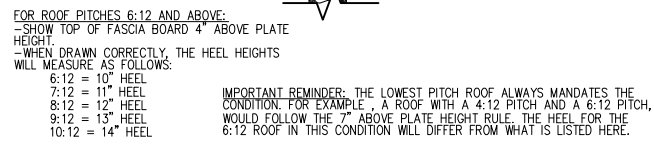
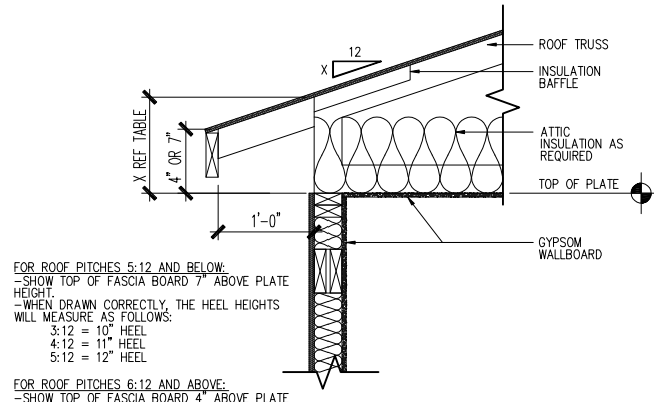

ENERGY HEEL DETAIL: CZ 2 & 3
 SCALE: 1" = 1'-0" ON 22x34, 1/2" = 1'-0" ON 11x17

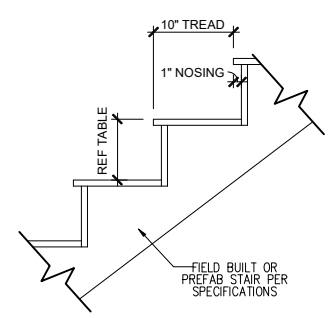

RISER HEIGHTS PER STAIR CONFIGURATION			
PLATE HEIGHT	10" FLOOR SYSTEM	14" FLOOR SYSTEM	16" FLOOR SYSTEM
8'-1 1/2"	14 RISERS @ 7 11/16"	15 RISERS @ 7 1/2"	15 RISERS @ 7 5/8"
9'-1 1/2"	16 RISERS @ 7 1/2"	16 RISERS @ 7 3/4"	17 RISERS @ 7 7/16"
10'-1 1/2"	17 RISERS @ 7 3/4"	18 RISERS @ 7 9/16"	18 RISERS @ 7 11/16"

TYPICAL STAIR DETAIL
 SCALE: 1" = 1'-0" ON 22x34, 1/2" = 1'-0" ON 11x17

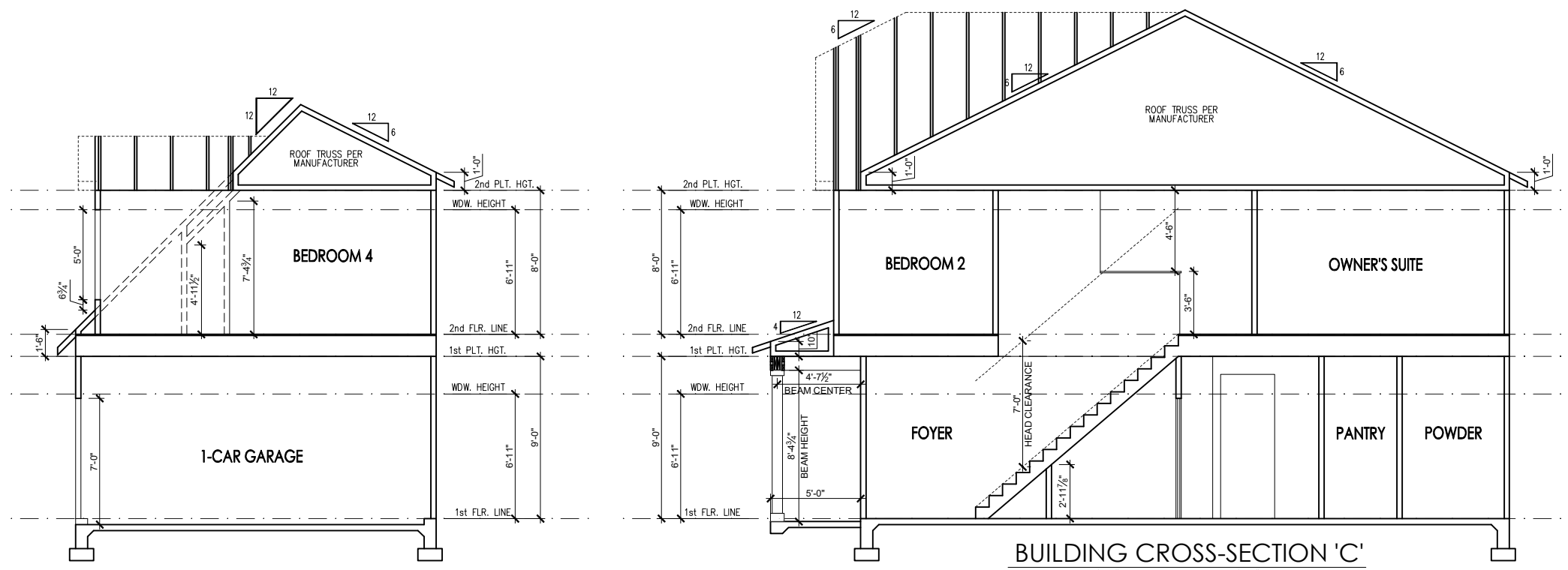

SECTION AT 1-CAR GARAGE
 SCALE: 1/4" = 1'-0" ON 22x34, 1/8" = 1'-0" ON 11x17

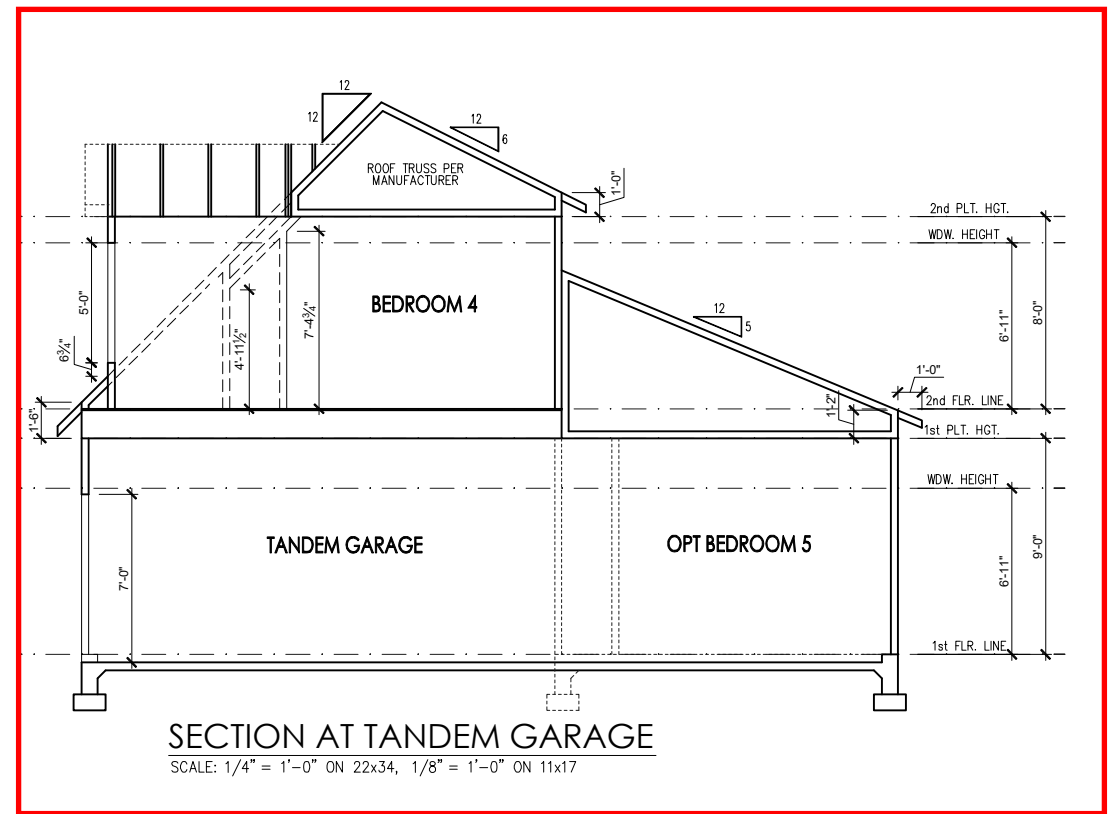

REV. #	DESCRIPTION	DATE
1	SEE COVERSHEET	01/28/22
2	SEE COVERSHEET	01/31/22
3	SEE COVERSHEET	02/08/22
4	SEE COVERSHEET	02/18/22
5	SEE COVERSHEET	05/05/22
6	SEE COVERSHEET	06/09/22
7	SEE COVERSHEET	07/22/22
8		

WILSON - RH
 Building Sections 'C'

DRAWN BY:
 South Designs
 ISSUE DATE:
 01/14/2022
 CURRENT REVISION DATE:

 SCALE:
 1/8" = 1'-0"
 SHEET
4.0c

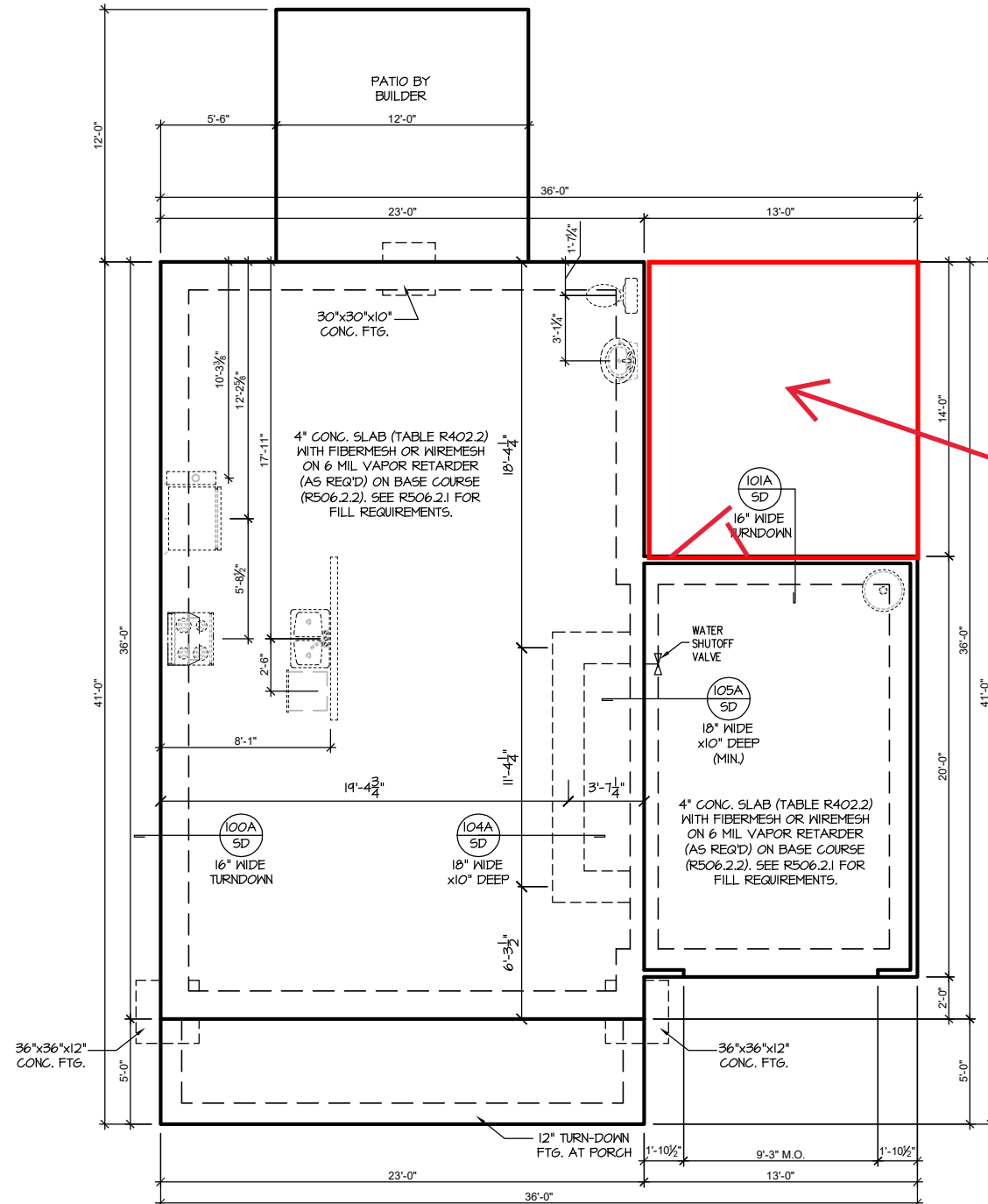

NOTE: ASSUMED SOIL BEARING CAPACITY = 2000 PSF CONTRACTOR MUST VERIFY SITE CONDITIONS AND CONTACT SOILS ENGINEER IF MARGINAL OR UNSTABLE SOILS ARE ENCOUNTERED

See Page S-1.1.1 for Bed 5

SLAB FOUNDATION ELEVATION 'C'
SCALE: 1/4" = 1'-0" ON 22x34, 1/8" = 1'-0" ON 11x17

Engineers seal applies only to structural components on this document.
Seal does not include construction means, methods, techniques, sequences, procedures or safety precautions.
Any deviations or discrepancies on plans are to be brought to the immediate attention of Southern Engineers. Failure to do so will void Southern Engineer's liability.
Seal is valid for projects permitted one year from date of seal.
Use of these plans constitutes approval of terms & conditions as defined in the customer agreement.

Southern Engineers, P.A.
3716 Benson Drive, Raleigh, NC 27609
Phone: (919) 878-1617
License: C-4772
www.southernengineers.com

NEW HOME, INC.

Wilson
Garage Right

PROJECT #
22-1192-RH

Engineers seal applies only to structural components on this document.
Seal does not include construction means, methods, techniques, sequences, procedures or safety precautions.
Any deviations or discrepancies on plans are to be brought to the immediate attention of Southern Engineers. Failure to do so will void Southern Engineer's liability.
Seal is valid for projects permitted one year from date of seal.
Use of these plans constitutes approval of terms & conditions as defined in the customer agreement.

Southern Engineers, P.A.
3716 Benson Drive, Raleigh, NC 27609
Phone: (919) 878-1617
License: C-4772
www.southernengineers.com

NEW HOME, INC.

Wilson
Garage Right

S-1.1.1

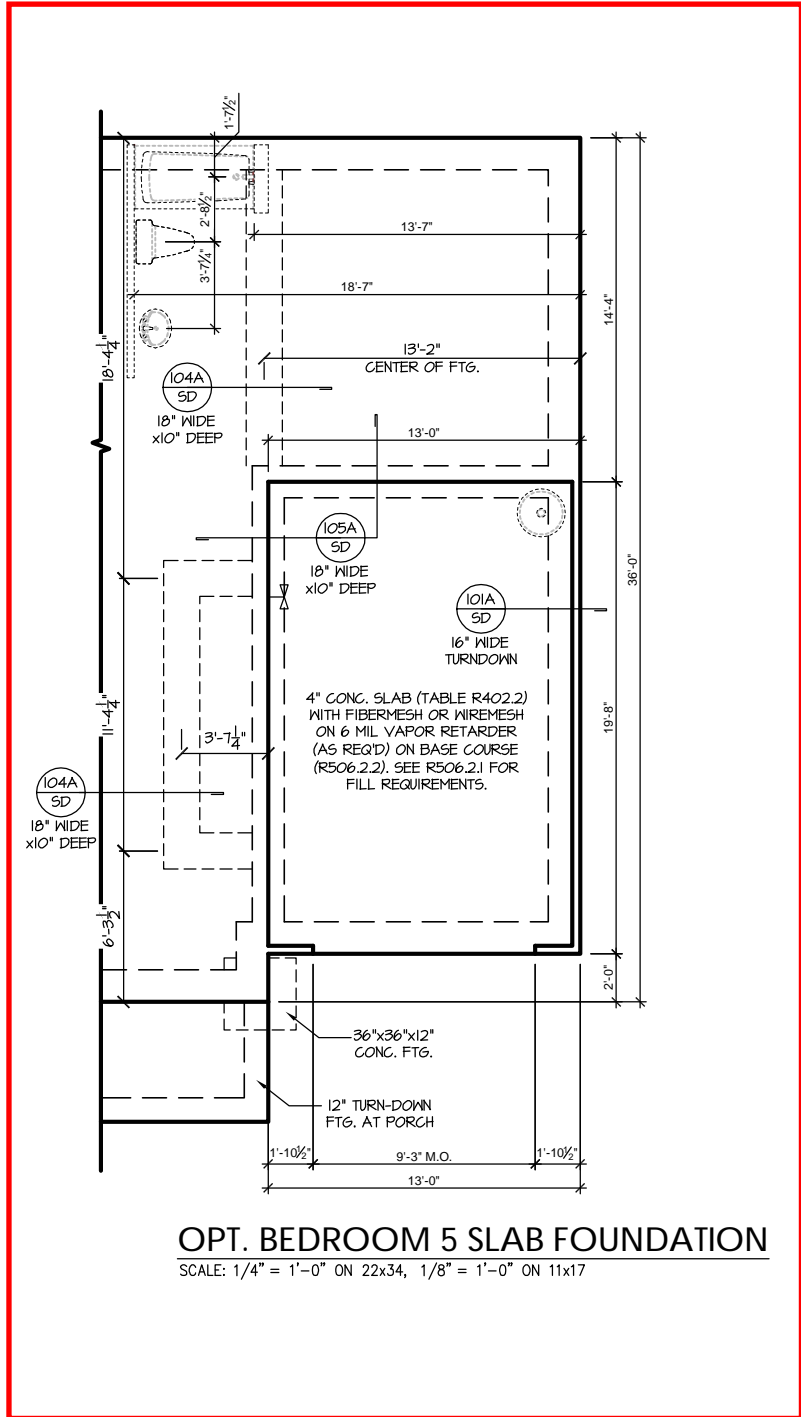



Engineers seal applies only to structural components on this document. Seal does not include construction means, methods, techniques, sequences, procedures or safety precautions. Any deviations or discrepancies on plans are to be brought to the immediate attention of Southern Engineers. Failure to do so will void Southern Engineer's liability. Seal is valid for projects permitted one year from date of seal. Use of these plans constitutes approval of terms & conditions as defined in the customer agreement.

Southern Engineers, P.A.
3716 Benson Drive, Raleigh, NC 27609
Phone: (919) 878-1617
License: C-4772
www.southernengineers.com

NEW HOME, INC.

Wilson
Garage Right

See Page S-2.1.1 for Bed 5

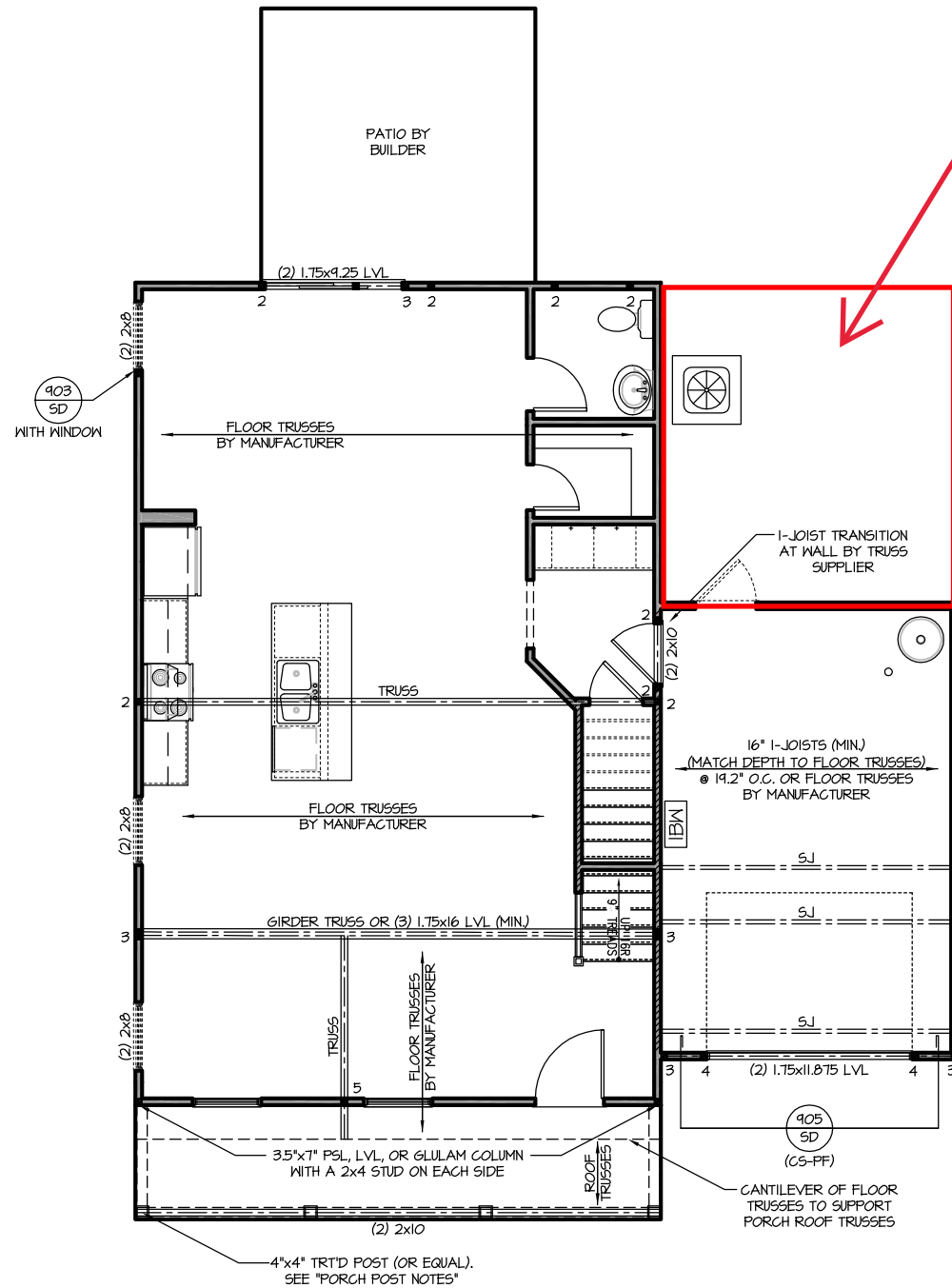

FIRST FLOOR - ELEVATION 'C'
SCALE: 1/4" = 1'-0" ON 22x34, 1/8" = 1'-0" ON 11x17

TRUSS SYSTEM REQUIREMENTS

NC (2018 NCRG): Wind: 115-120 mph

1. TRUSS SYSTEM LAYOUTS (PLACEMENT PLANS) SHALL BE DESIGNED IN ACCORDANCE WITH SEALED STRUCTURAL PLANS. ANY NEED TO CHANGE TRUSSES SHALL BE COORDINATED WITH SOUTHERN ENGINEERS.
2. TRUSS SCHEMATICS (PROFILES) SHALL BE PREPARED AND SEALED BY TRUSS MANUFACTURER.
3. ALL TRUSSES SHALL BE DESIGNED FOR BEARING ON SPF #2 OR #3 PLATES OR LEDGERS (UNO).
4. ALL REQUIRED ANCHORS FOR TRUSSES DUE TO UPLIFT OR BEARING SHALL MEET THE REQUIREMENTS AS SPECIFIED ON THE TRUSS SCHEMATICS.

HEADER/BEAM & COLUMN NOTES

1. ALL EXTERIOR AND LOAD BEARING HEADERS SHALL BE MIN. (2)2x6 (4" WALL) OR (3)2x6 (6" WALL) WITH (1) SUPPORT STUD, UNLESS NOTED OTHERWISE.
2. THE NUMBER SHOWN AT BEAM AND HEADER SUPPORTS INDICATES THE NUMBER OF SUPPORT STUDS REQUIRED IN STUD POCKET OR COLUMN. THE NUMBER OF KING STUDS AT EACH END OF HEADERS IN EXTERIOR WALLS SHALL BE ACCORDING TO ITEM "d" IN TABLE R602.3(5) OR AS BELOW PER NCDOT COMMENTARY "KING STUDS AT WALL OPENINGS" REVISED 1-4-2020:
 - UP TO 3' SPAN: (1) KING STUD
 - OVER 3' UP TO 6' SPAN: (2) KING STUDS
 - OVER 6' UP TO 9' SPAN: (3) KING STUDS
 - OVER 9' UP TO 12' SPAN: (4) KING STUDS
 - OVER 12' UP TO 15' SPAN: (5) KING STUDS

FRAMING NOTES

NC (2018 NCRG): Wind: 115-120 mph

1. BRACING METHOD AND TYPE: CONTINUOUSLY SHEATHED WSP. GS-WSP. NOTE THAT THE WALL BRACING AMOUNT PROVIDED ON THE PLANS (DETAILS AND SPECIFICATIONS) IS GREATER THAN THE AMOUNT OF WALL BRACING REQUIRED BY SECTION R602.10 OF THE CODE. SEE NOTES BELOW FOR DETAILS AND SPECIFICATIONS FOR WALL BRACING AND WALL FRAMING.
2. EXTERIOR WALL SHEATHING: WALLS SHALL BE BRACED BY SHEATHING WALLS ON ALL STORIES WITH WOOD STRUCTURAL PANEL SHEATHING (WSP) (EXPOSURE B: 7/16", EXPOSURE C: 15/32"). SHEATHING SHALL BE ATTACHED WITH 8d NAILS AT A 6"1/2" NAILING PATTERN (6" OC AT PANEL EDGES AND 12" OC AT INTERMEDIATE SUPPORTS). INSTALL BLOCKING AT ALL PANEL EDGES.
3. WSP SHEATHING SHALL EXTEND TO THE UPPERMOST DOUBLE BEARING PLATE. BLOCK AT ROOF PER SECTION R602.10.4.5 AND ATTACH BRACED WALLS PER CODE. WSP SHEATHING BETWEEN FLOORS SHALL BE SPLICED ALONG CONTINUOUS BAND OR THE WSP SHEATHING MAY BE SPLICED ACROSS STUDS (CONTINUOUS ACROSS FLOOR SYSTEM) WITH BLOCKING AT PANEL EDGES. (MINIMUM 12" BEYOND FLOOR BREAK) OR OTHER APPROVED METHOD.
4. "HD" = HOLD-DOWN: HOLD-DOWN DEVICE (NOTED AS "HD" ON PLANS) SHALL BE AN 800 POUND CAPACITY ASSEMBLY AS NOTED ON PLANS. SEE DETAILS FOR HD ASSEMBLY.
 - **GROUND/FIRST FLOOR: USE "HD HOLD-DOWN DETAIL" ON SD SHEET (OR EQUIV.)
 - **UPPER FLOORS: ATTACH BASE OF KING STUD WITH A SIMPSON GS22 STRAP DOWN ACROSS THE BAND AND DOWN TO A STUD BELOW OR HEADER BELOW. EXTEND STRAP 1" MIN. ALONG EACH STUD (OR HEADER) AND ATTACH EACH END W/ (7) 8d NAILS.
5. INTERIOR BRACED WALL: (NOTED AS "IBW" ON PLANS) ATTACH 1/2" GYPSUM BOARD (GB) ON EACH SIDE OF WALL WITH A MIN. OF 5d COOLER NAILS OR #6 SCREWS @ 7" O.C. ALONG THE EDGES AND AT INTERMEDIATE SUPPORTS.
6. INTERIOR BRACED WALL-WOOD STRUCTURAL PANEL: (NOTED AS "IBW-WSP" ON PLANS). ATTACH ONE SIDE WITH 3/8" WSP SHEATHING WITH 8d NAILS AT A 6"1/2" NAILING PATTERN (6" OC AT PANEL EDGES AND 12" OC AT INTERMEDIATE SUPPORTS). INSTALL BLOCKING AT ALL PANEL EDGES. ATTACH GB OVER WSP AS REQUIRED. ATTACH OPPOSITE SIDE WITH 1/2" GB WITH A MIN. OF 5d COOLER NAILS OR #6 SCREWS @ 7" OC ALONG THE EDGES AND AT INTERMEDIATE SUPPORTS.

PORCH POST NOTES:

- 4"x4" (6"x6") TRTD POST (OR EQUAL).
- ATTACH TRUSSES (RAFTERS) AT PORCH WITH HURRICANE CONNECTORS.
- 1. POST GAP: SIMPSON AC4-MAX (AC6-MAX)
- 2. POST GAP AT CORNER: (2) SIMPSON LCE4 (MITER HEADER AT CORNER). HIGH WIND; ADD (1) SIMPSON H6.
- 3. POST BASE: SIMPSON ABU44 (ABU66).
 - 3.1. MONO: 3/8" ANCHOR (EMBED 7")
 - 3.2. GML: 3/8" ANCHOR (EXTEND TO FOOTING - HIGH WIND ONLY)
- 4. POST BASE: WOOD FOUNDATION: (2) SIMPSON CS16 STRAPS AT POSTS. EXTEND 12" ONTO EACH POST (UPPER AND LOWER) OR TO GIRDER.
- NOTE: EQUIVALENT POST GAP AND BASE ACCEPTABLE.

WOOD I-JOISTS

(SHALL BE ONE OF THE FOLLOWING):

- TJI 210 BY TRUS JOIST
- LFI 20 PLUS BY LP
- BCI 5000s 18 BY BC
- ALL WOOD I-JOISTS SHALL BE INSTALLED ACCORDING TO MANUFACTURER'S SPECIFICATIONS.
- INSTALL SQUASH BLOCKS, WEB STIFFENERS, ETC. AS REQUIRED BY AND ACCORDING TO THE I-JOIST MANUFACTURER'S SPECIFICATIONS AND INSTRUCTIONS.
- HANGERS FOR I-JOISTS ARE THE RESPONSIBILITY OF THE I-JOIST SUPPLIER.

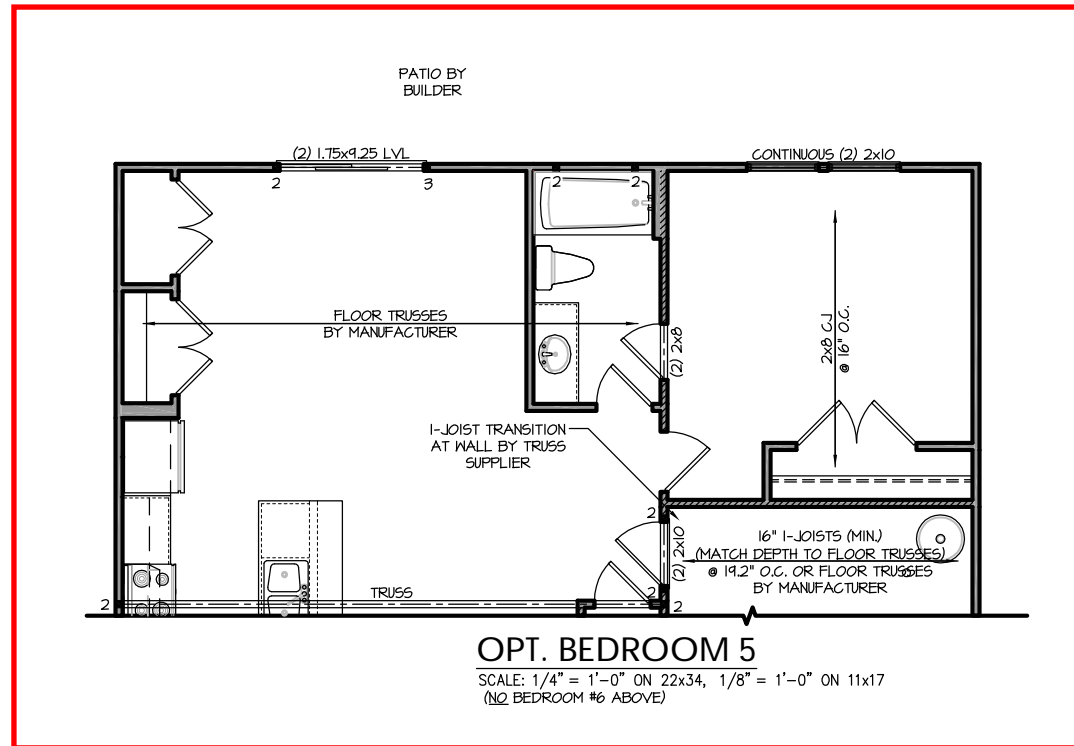
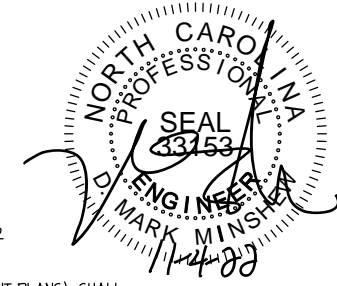

PORCH POST NOTES:

- 4"x4" (6"x6") TRTD POST (OR EQUAL).
- ATTACH TRUSSES (RAFTERS) AT PORCH WITH HURRICANE CONNECTORS.
- 1. POST CAP: SIMPSON AC4-MAX (AC6-MAX)
- 2. POST CAP AT CORNER: (2) SIMPSON LCE4 (MITER HEADER AT CORNER). HIGH WIND; ADD (1) SIMPSON H6.
- 3. POST BASE: SIMPSON ABU44 (ABU66).
- 3.1. MONO: 3/8" ANCHOR (EMBED T)
- 3.2. CML: 3/8" ANCHOR (EXTEND TO FOOTING - HIGH WIND ONLY)
- 4. POST BASE: WOOD FOUNDATION: (2) SIMPSON CS16 STRAPS AT POSTS. EXTEND 12" ONTO EACH POST (UPPER AND LOWER) OR TO GIRDER.
- NOTE: EQUIVALENT POST CAP AND BASE ACCEPTABLE.

WOOD I-JOISTS

(SHALL BE ONE OF THE FOLLOWING):

- TJI 210 BY TRUSS JOIST
- LPI 20 PLUS BY LP
- BCI 5000s 1.8 BY BC
- ALL WOOD I-JOISTS SHALL BE INSTALLED ACCORDING TO MANUFACTURER'S SPECIFICATIONS.
- INSTALL SQUASH BLOCKS, WEB STIFFENERS, ETC. AS REQUIRED BY AND ACCORDING TO THE I-JOIST MANUFACTURER'S SPECIFICATIONS AND INSTRUCTIONS.
- HANGERS FOR I-JOISTS ARE THE RESPONSIBILITY OF THE I-JOIST SUPPLIER.

OPTIONS WITHOUT
BEDROOM #6 ABOVE

TRUSS SYSTEM REQUIREMENTS

NC (2018 NRC): Wind: 115-120 mph

1. TRUSS SYSTEM LAYOUTS (PLACEMENT PLANS) SHALL BE DESIGNED IN ACCORDANCE WITH SEALED STRUCTURAL PLANS. ANY NEED TO CHANGE TRUSSES SHALL BE COORDINATED WITH SOUTHERN ENGINEERS.
2. TRUSS SCHEMATICS (PROFILES) SHALL BE PREPARED AND SEALED BY TRUSS MANUFACTURER.
3. ALL TRUSSES SHALL BE DESIGNED FOR BEARING ON SPF #2 OR #3 PLATES OR LEDGERS (UNO).
4. ALL REQUIRED ANCHORS FOR TRUSSES DUE TO UPLIFT OR BEARING SHALL MEET THE REQUIREMENTS AS SPECIFIED ON THE TRUSS SCHEMATICS.

HEADER/BEAM & COLUMN NOTES

1. ALL EXTERIOR AND LOAD BEARING HEADERS SHALL BE MIN. (2)2x6 (4" WALL) OR (3)2x6 (6" WALL) WITH (1) SUPPORT STUD, UNLESS NOTED OTHERWISE.
2. THE NUMBER SHOWN AT BEAM AND HEADER SUPPORTS INDICATES THE NUMBER OF SUPPORT STUDS REQUIRED IN STUD POCKET OR COLUMN. THE NUMBER OF KING STUDS AT EACH END OF HEADERS IN EXTERIOR WALLS SHALL BE ACCORDING TO ITEM "d" IN TABLE R602.3(5) OR AS BELOW PER NCD01 COMMENTARY "KING STUDS AT WALL OPENINGS" REVISED 1-4-2020:
 - UP TO 3' SPAN: (1) KING STUD
 - OVER 3' UP TO 6' SPAN: (2) KING STUDS
 - OVER 6' UP TO 9' SPAN: (3) KING STUDS
 - OVER 9' UP TO 12' SPAN: (4) KING STUDS
 - OVER 12' UP TO 15' SPAN: (5) KING STUDS

FRAMING NOTES

NC (2018 NRC): Wind: 115-120 mph

1. BRACING METHOD AND TYPE: CONTINUOUSLY SHEATHED WSP. CS-WSP. NOTE THAT THE WALL BRACING AMOUNT PROVIDED ON THE PLANS (DETAILS AND SPECIFICATIONS) IS GREATER THAN THE AMOUNT OF WALL BRACING REQUIRED BY SECTION R602.10 OF THE CODE. SEE NOTES BELOW FOR DETAILS AND SPECIFICATIONS FOR WALL BRACING AND WALL FRAMING.
2. EXTERIOR WALL SHEATHING: WALLS SHALL BE BRACED BY SHEATHING WALLS ON ALL STORIES WITH WOOD STRUCTURAL PANEL SHEATHING (WSP) (EXPOSURE B: 1/16", EXPOSURE C: 15/32"). SHEATHING SHALL BE ATTACHED WITH 8d NAILS AT A 6"1/2" NAILING PATTERN (6" OC AT PANEL EDGES AND 12" OC AT INTERMEDIATE SUPPORTS). INSTALL BLOCKING AT ALL PANEL EDGES.
3. WSP SHEATHING SHALL EXTEND TO THE UPPERMOST DOUBLE BEARING PLATE. BLOCK AT ROOF PER SECTION R602.10.4.5 AND ATTACH BRACED WALLS PER CODE. WSP SHEATHING BETWEEN FLOORS SHALL BE SPLICED ALONG CONTINUOUS BAND OR THE WSP SHEATHING MAY BE SPLICED ACROSS STUDS (CONTINUOUS ACROSS FLOOR SYSTEM) WITH BLOCKING AT PANEL EDGES. (MINIMUM 12" BEYOND FLOOR BREAK) OR OTHER APPROVED METHOD.
4. "HD" = HOLD-DOWN: HOLD-DOWN DEVICE (NOTED AS "HD" ON PLANS) SHALL BE AN 800 POUND CAPACITY ASSEMBLY AS NOTED ON PLANS. SEE DETAILS FOR HD ASSEMBLY.
 - **GROUND/FIRST FLOOR: USE "HD HOLD-DOWN DETAIL" ON SD SHEET (OR EQUIV.)
 - **UPPER FLOORS: ATTACH BASE OF KING STUD WITH A SIMPSON CS22 STRAP DOWN ACROSS THE BAND AND DOWN TO A STUD BELOW OR HEADER BELOW. EXTEND STRAP 7" MIN ALONG EACH STUD (OR HEADER) AND ATTACH EACH END W/ (1) 8d NAILS.
5. INTERIOR BRACED WALL: (NOTED AS "IBW" ON PLANS) ATTACH 1/2" GYPSUM BOARD (GB) ON EACH SIDE OF WALL WITH A MIN. OF 5d COOLER NAILS OR #6 SCREWS @ 1" O.C. ALONG THE EDGES AND AT INTERMEDIATE SUPPORTS.
6. INTERIOR BRACED WALL-WOOD STRUCTURAL PANEL: (NOTED AS "IBW/WSP" ON PLANS). ATTACH ONE SIDE WITH 1/16" WSP SHEATHING WITH 8d NAILS AT A 6"1/2" NAILING PATTERN (6" OC AT PANEL EDGES AND 12" OC AT INTERMEDIATE SUPPORTS). INSTALL BLOCKING AT ALL PANEL EDGES. ATTACH GB OVER WSP AS REQUIRED. ATTACH OPPOSITE SIDE WITH 1/2" GB WITH A MIN. OF 5d COOLER NAILS OR #6 SCREWS @ 1" O.C. ALONG THE EDGES AND AT INTERMEDIATE SUPPORTS.

Engineers seal applies only to structural components on this document. Seal does not include construction means, methods, techniques, sequences, procedures or safety precautions. Any deviations or discrepancies on plans are to be brought to the immediate attention of Southern Engineers. Failure to do so will void Southern Engineer's liability. Seal is valid for projects permitted one year from date of seal. Use of these plans constitutes approval of terms & conditions as defined in the customer agreement.

Southern Engineers, P.A.
3716 Benson Drive, Raleigh, NC 27609
Phone: (919) 878-1617
License: C-4772
www.southernengineers.com

NEW HOME, INC.

Wilson
Garage Right



Engineers seal applies only to structural components on this document.
Seal does not include construction means, methods, techniques, sequences, procedures or safety precautions.
Any deviations or discrepancies on plans are to be brought to the immediate attention of Southern Engineers. Failure to do so will void Southern Engineer's liability.
Seal is valid for projects permitted one year from date of seal.
Use of these plans constitutes approval of terms & conditions as defined in the customer agreement.

Southern Engineers, P.A.
3716 Benson Drive, Raleigh, NC 27609
Phone: (919) 878-1617
License: C-4772
www.southernengineers.com

NEW HOME, INC.

Wilson
Garage Right

TRUSS SYSTEM REQUIREMENTS

NC (2018 NCRS): Wind: 115-120 mph

1. TRUSS SYSTEM LAYOUTS (PLACEMENT PLANS) SHALL BE DESIGNED IN ACCORDANCE WITH SEALED STRUCTURAL PLANS. ANY NEED TO CHANGE TRUSSES SHALL BE COORDINATED WITH SOUTHERN ENGINEERS.
2. TRUSS SCHEMATICS (PROFILES) SHALL BE PREPARED AND SEALED BY TRUSS MANUFACTURER.
3. ALL TRUSSES SHALL BE DESIGNED FOR BEARING ON SFF #2 OR #3 PLATES OR LEDGERS (UNO).
4. ALL REQUIRED ANCHORS FOR TRUSSES DUE TO UPLIFT OR BEARING SHALL MEET THE REQUIREMENTS AS SPECIFIED ON THE TRUSS SCHEMATICS.

HEADER/BEAM & COLUMN NOTES

1. ALL EXTERIOR AND LOAD BEARING HEADERS SHALL BE MIN. (2)2x6 (4" WALL) OR (3)2x6 (6" WALL) WITH (1) SUPPORT STUD, UNLESS NOTED OTHERWISE.
2. THE NUMBER SHOWN AT BEAM AND HEADER SUPPORTS INDICATES THE NUMBER OF SUPPORT STUDS REQUIRED IN STUD POCKET OR COLUMN. THE NUMBER OF KING STUDS AT EACH END OF HEADERS IN EXTERIOR WALLS SHALL BE ACCORDING TO ITEM "d" IN TABLE R602.3(5) OR AS BELOW PER NCD01 COMMENTARY "KING STUDS AT WALL OPENINGS" REVISED 1-9-2020:
 - UP TO 3' SPAN: (1) KING STUD
 - OVER 3' UP TO 6' SPAN: (2) KING STUDS
 - OVER 6' UP TO 9' SPAN: (3) KING STUDS
 - OVER 9' UP TO 12' SPAN: (4) KING STUDS
 - OVER 12' UP TO 15' SPAN: (5) KING STUDS

FRAMING NOTES

NC (2018 NCRS): Wind: 115-120 mph

1. BRACING METHOD AND TYPE: CONTINUOUSLY SHEATHED WSP. NOTE THAT THE WALL BRACING AMOUNT PROVIDED ON THE PLANS (DETAILS AND SPECIFICATIONS) IS GREATER THAN THE AMOUNT OF WALL BRACING REQUIRED BY SECTION R602.10 OF THE CODE. SEE NOTES BELOW FOR DETAILS AND SPECIFICATIONS FOR WALL BRACING AND WALL FRAMING.
2. EXTERIOR WALL SHEATHING: WALLS SHALL BE BRACED BY SHEATHING WALLS ON ALL STORIES WITH WOOD STRUCTURAL PANEL SHEATHING (WSP) (EXPOSURE B: 7/16", EXPOSURE C: 15/32"). SHEATHING SHALL BE ATTACHED WITH 8d NAILS AT A 6"X12" NAILING PATTERN (6" OC AT PANEL EDGES AND 12" OC AT INTERMEDIATE SUPPORTS). INSTALL BLOCKING AT ALL PANEL EDGES.
3. WSP SHEATHING SHALL EXTEND TO THE UPPERMOST DOUBLE BEARING PLATE. BLOCK AT ROOF PER SECTION R602.10.4.5 AND ATTACH BRACED WALLS PER CODE. WSP SHEATHING BETWEEN FLOORS SHALL BE SPLICED ALONG CONTINUOUS BAND OR THE WSP SHEATHING MAY BE SPLICED ACROSS STUDS (CONTINUOUS ACROSS FLOOR SYSTEM) WITH BLOCKING AT PANEL EDGES. (MINIMUM 12" BEYOND FLOOR BREAK) OR OTHER APPROVED METHOD.
4. "HD" = HOLD-DOWN: HOLD-DOWN DEVICE (NOTED AS "HD" ON PLANS) SHALL BE AN 800 POUND CAPACITY ASSEMBLY AS NOTED ON PLANS. SEE DETAILS FOR HD ASSEMBLY.
 - **GROUND/FIRST FLOOR: USE "HD HOLD-DOWN DETAIL" ON SD SHEET (OR EQUIV.)
 - **UPPER FLOORS: ATTACH BASE OF KING STUD WITH A SIMPSON CS22 STRAP DOWN ACROSS THE BAND AND DOWN TO A STUD BELOW OR HEADER BELOW. EXTEND STRAP 1" MIN ALONG EACH STUD (OR HEADER) AND ATTACH EACH END W/ (1) 8d NAILS.
5. INTERIOR BRACED WALL: (NOTED AS "IBW" ON PLANS) ATTACH 1/2" GYPSUM BOARD (GB) ON EACH SIDE OF WALL WITH A MIN. OF 5d COOLER NAILS OR #6 SCREWS @ 7" O.C. ALONG THE EDGES AND AT INTERMEDIATE SUPPORTS.
6. INTERIOR BRACED WALL-WOOD STRUCTURAL PANEL: (NOTED AS "IBW-WSP" ON PLANS). ATTACH ONE SIDE WITH 1/4" WSP SHEATHING WITH 8d NAILS AT A 6"X12" NAILING PATTERN (6" OC AT PANEL EDGES AND 12" OC AT INTERMEDIATE SUPPORTS). INSTALL BLOCKING AT ALL PANEL EDGES. ATTACH GB OVER WSP AS REQUIRED. ATTACH OPPOSITE SIDE WITH 1/2" GB WITH A MIN. OF 5d COOLER NAILS OR #6 SCREWS @ 7" OC ALONG THE EDGES AND AT INTERMEDIATE SUPPORTS.

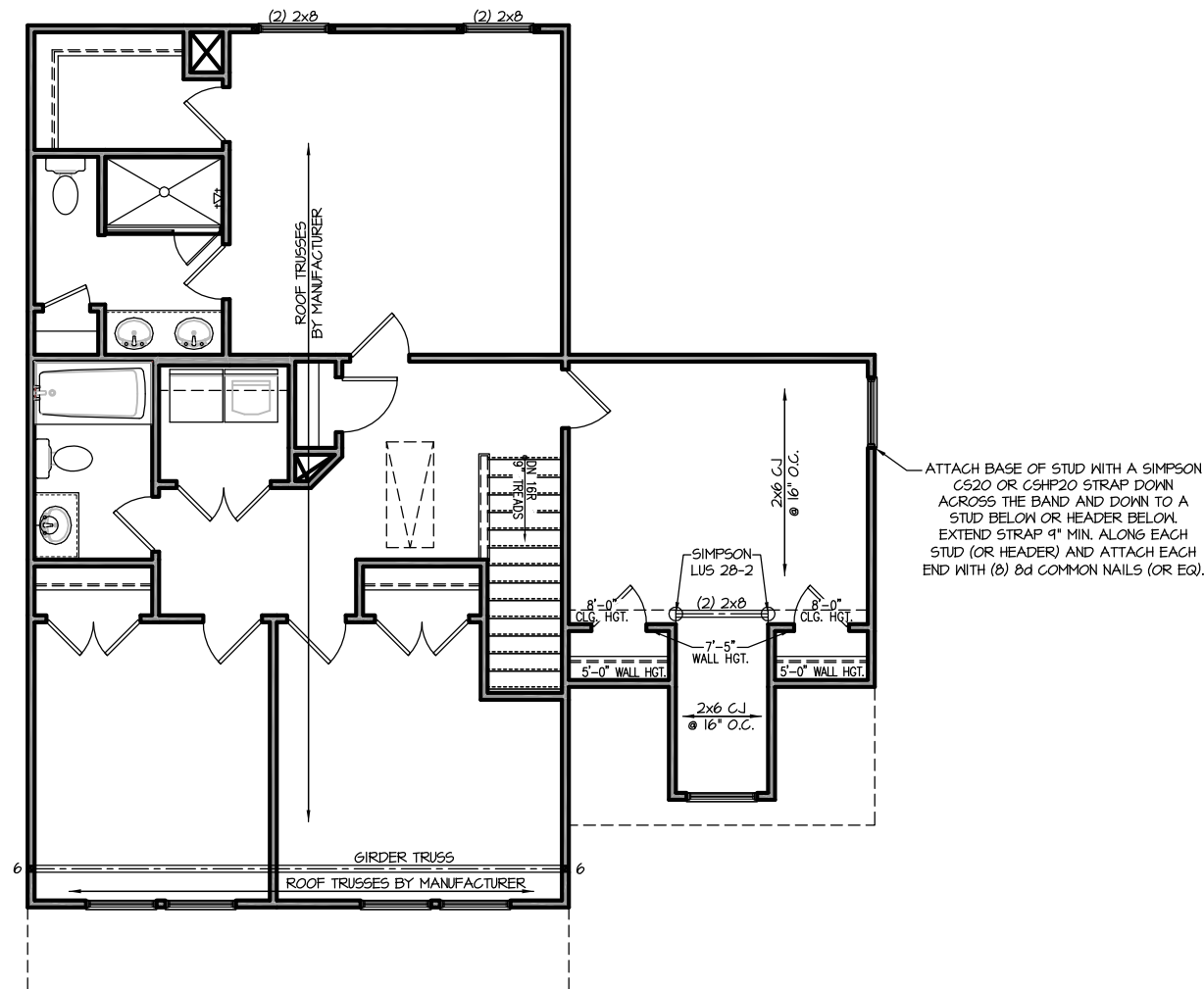

SECOND FLOOR ELEVATION 'C'

SCALE: 1/4" = 1'-0" ON 22x34, 1/8" = 1'-0" ON 11x17



TRUSS SYSTEM REQUIREMENTS

NC (2018 NRC): Wind: 115-120 mph

- TRUSS SYSTEM LAYOUTS (PLACEMENT PLANS) SHALL BE DESIGNED IN ACCORDANCE WITH SEALED STRUCTURAL PLANS. ANY NEED TO CHANGE TRUSSES SHALL BE COORDINATED WITH SOUTHERN ENGINEERS.
- TRUSS SCHEMATICS (PROFILES) SHALL BE PREPARED AND SEALED BY TRUSS MANUFACTURER.
- ALL TRUSSES SHALL BE DESIGNED FOR BEARING ON SPF #2 OR #3 PLATES OR LEDGERS (UNO).
- ALL REQUIRED ANCHORS FOR TRUSSES DUE TO UPLIFT OR BEARING SHALL MEET THE REQUIREMENTS AS SPECIFIED ON THE TRUSS SCHEMATICS.

ROOF FRAMING NOTES:

NC (2018 NRC): Wind: 115-120 mph

- 2x8 RAFTERS @ 16" O.C. WITH 2x10 RIDGE, UNO.
 - (2) 2x10 OR 1.75x11.875 LVL HIP, (2) 2x10 HIPs MAY BE SPLICED WITH A MIN. 6'-0" OVERLAP AT CENTER
 - (2) 2x10 OR 1.75x9.25 LVL VALLEY. DO NOT SPLICE VALLEYS
 - 1.75x11.875 LVL OR (2)1.75x9.25 LVL VALLEY
 - FALSE FRAME VALLEY ON 2x10 FLAT PLATE
 - 2x6 RAFTERS @ 16" O.C. W/ 2x8 RIDGE, UNO.
 - 2x10 RAFTERS @ 16" O.C. W/ 2x12 RIDGE, UNO.
 - EXTEND RIDGE 12" BEYOND INTERSECTION
- "SR" = SINGLE RAFTER
 - "DR" = DOUBLE RAFTER
 - "TR" = TRIPLE RAFTER
 - "RS" = ROOF SUPPORT
 - "■" = (3) STUD OR 4x4 POST FOR ROOF SUPPORT (USE 2x6 STUDS OR 6x6 POST FOR SUPPORT OVER 10'-0" IN HEIGHT)
 - ATTACH VAULTED RAFTERS WITH HURRICANE CLIPS. SIMPSON "H-25A" OR EQUIVALENT. TIES TO BE INSTALLED ON THE OUTSIDE FACE OF FRAMING.
 - INSTALL RAFTER TIES AND COLLAR TIES PER SECTION RA0231 OF THE 2018 NC RESIDENTIAL CODE.

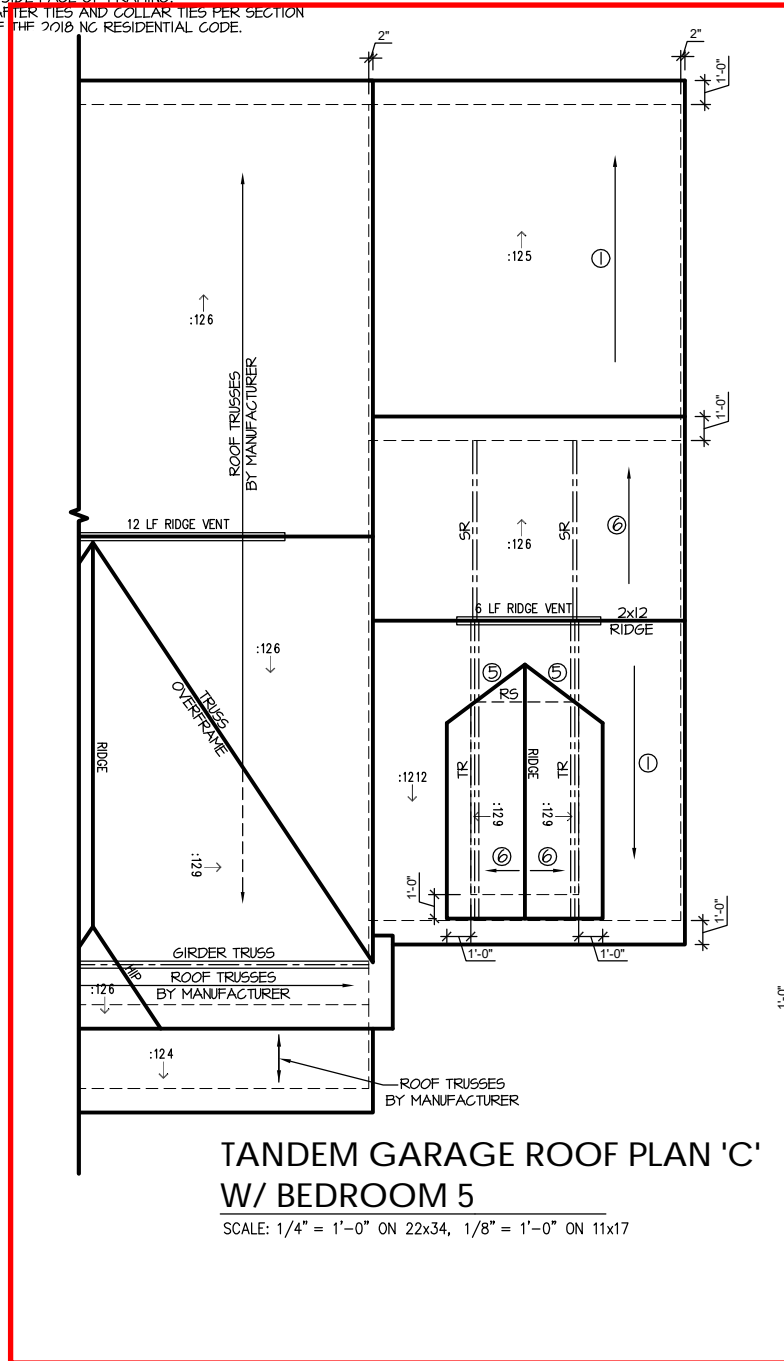

**TANDEM GARAGE ROOF PLAN 'C'
W/ BEDROOM 5**
SCALE: 1/4" = 1'-0" ON 22x34, 1/8" = 1'-0" ON 11x17

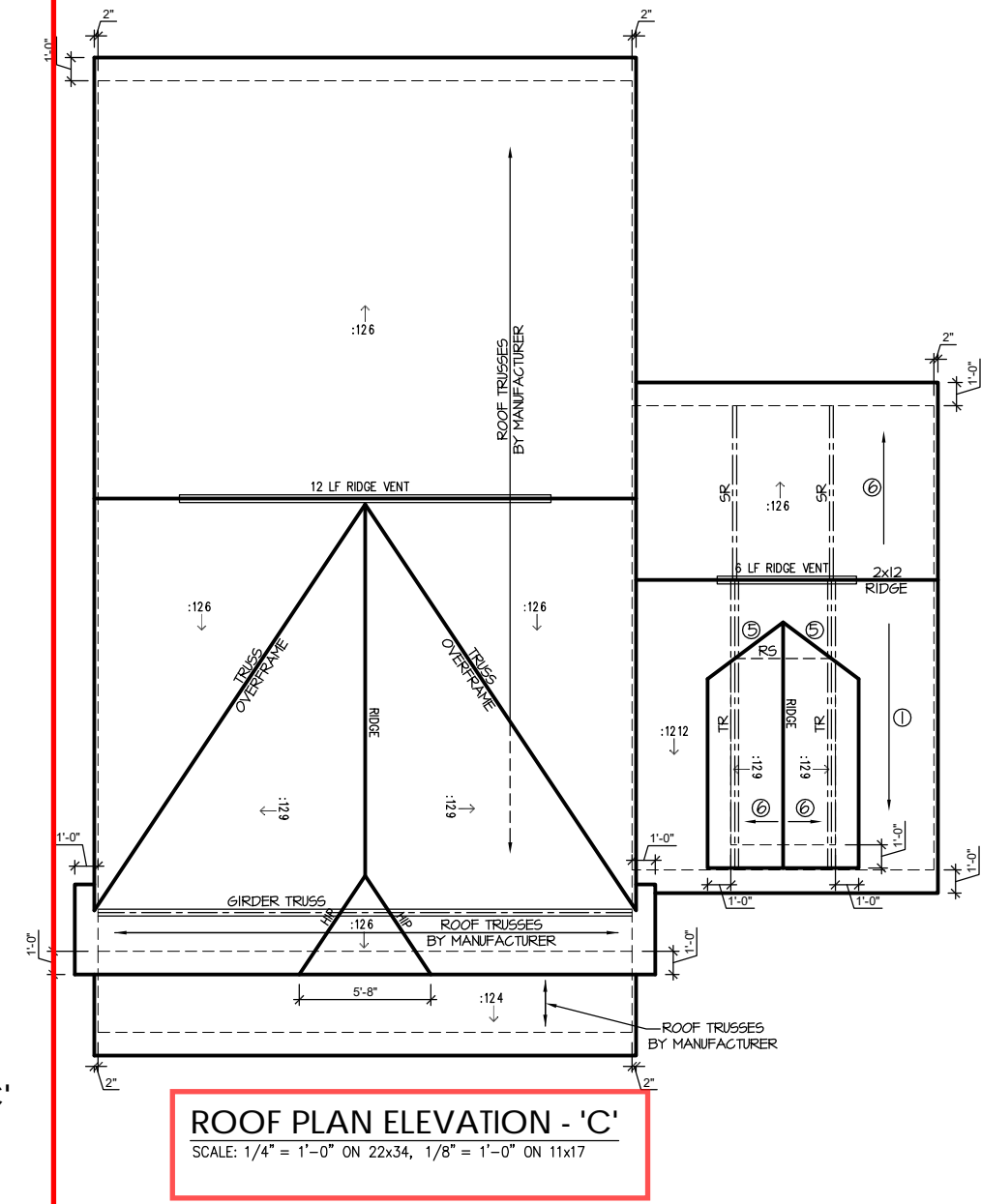

ROOF PLAN ELEVATION - 'C'
SCALE: 1/4" = 1'-0" ON 22x34, 1/8" = 1'-0" ON 11x17

Engineers seal applies only to structural components on this document. Seal does not include construction means, methods, techniques, sequences, procedures or safety precautions. Any deviations or discrepancies on plans are to be brought to the immediate attention of Southern Engineers. Failure to do so will void Southern Engineer's liability. Seal is valid for projects permitted one year from date of seal. Use of these plans constitutes approval of terms & conditions as defined in the customer agreement.

Southern Engineers, P.A.
3716 Benson Drive, Raleigh, NC 27609
Phone: (919) 878-1617
License: C-4772
www.southernengineers.com

NEW HOME, INC.

**Wilson
Garage Right**

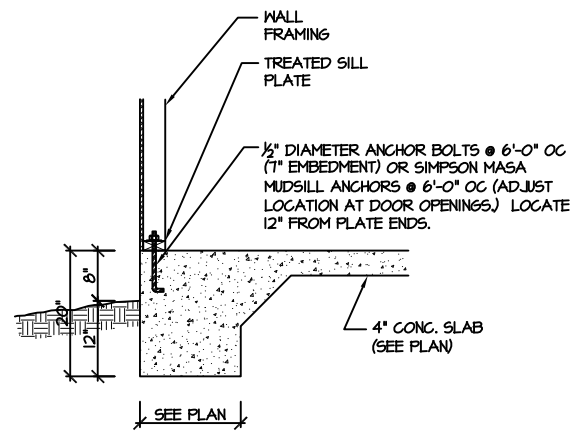

115-120 MPH (100A SD) MONOLITHIC SLAB FOOTING
(SIDING OR EQUAL)

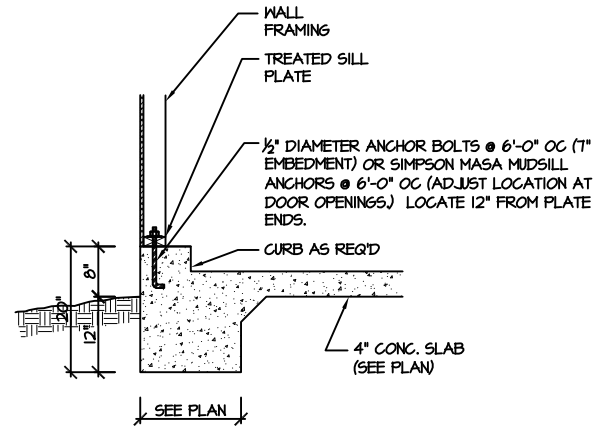

115-120 MPH (101A SD) MONOLITHIC SLAB @ GARAGE
(SIDING OR EQUAL)

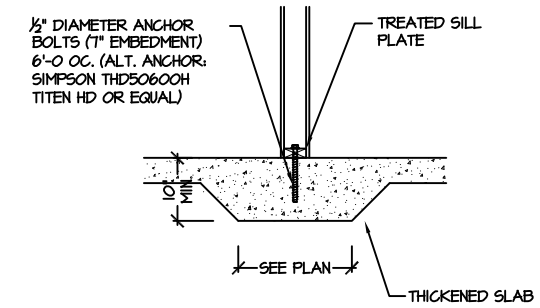

115-120 MPH (104A SD) THICKENED SLAB
(INTERIOR BEARING WALL)

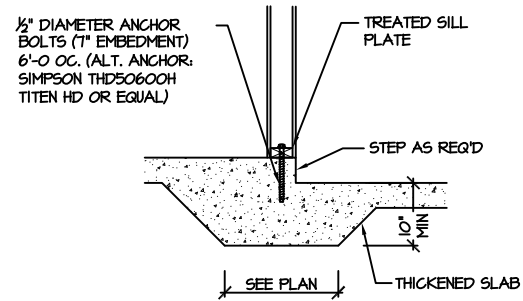

115-120 MPH (105A SD) THICKENED SLAB @ GARAGE
(INTERIOR GARAGE WALL)

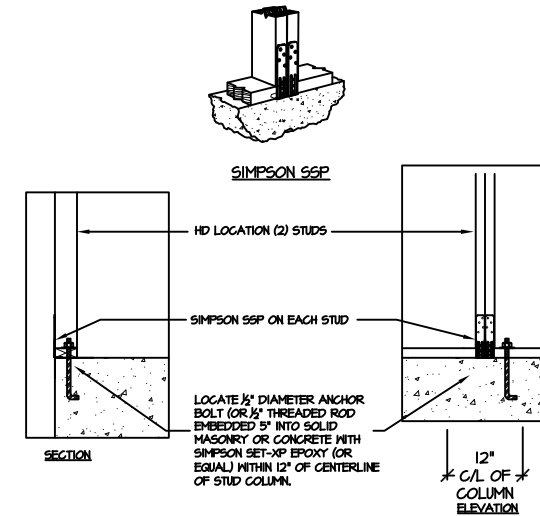

903 SD BRACED WALL END CONDITION "HD" HOLD-DOWN DETAIL
NOTE: SIMPSON DTT-1Z IS ACCEPTABLE ALTERNATE
NOTE: ALTERNATE HD HOLD-DOWN DEVICES OR SYSTEMS MAY BE USED TO MEET THE CODE REQUIRED 800 LB CAPACITY IN LIEU OF THE ABOVE DETAIL.

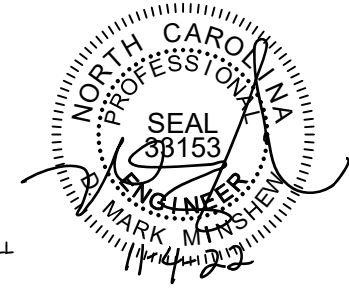

PROJECT #
22-1192

Engineers seal applies only to structural components on this document.
Seal does not include construction means, methods, techniques, sequences, procedures or safety precautions.
Any deviations or discrepancies on plans are to be brought to the immediate attention of Southern Engineers. Failure to do so will void Southern Engineer's liability.
Seal is valid for projects permitted one year from date of seal.
Use of these plans constitutes approval of terms & conditions as defined in the customer agreement.

Southern Engineers, P.A.
3716 Benson Drive, Raleigh, NC 27609
Phone: (919) 878-1617
License: C-4772
www.southernengineers.com

NEW HOME, INC

WILSON

SD

MONO-SLAB FOUNDATION

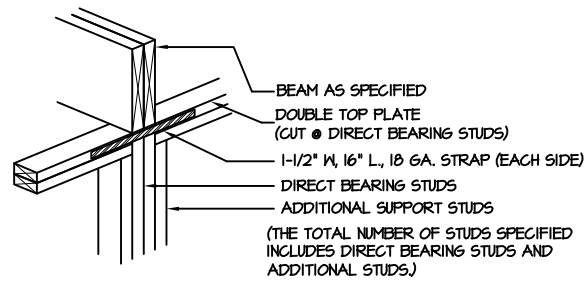

205A DIRECT STUD BEARING
SD NTS



STRUCTURAL NOTES
NC (2018 NCRG): Wind: 115-120 mph

- ENGINEER'S SEAL APPLIES ONLY TO STRUCTURAL COMPONENTS INCLUDING ROOF RAFTERS, HIPs, VALLEYS, RIDGES, FLOORS, WALLS, BEAMS AND HEADERS, COLUMNS, CANTILEVERS, OFFSET LOAD BEARING WALLS, PIER & GIRDER SYSTEM, FOOTING, AND PILING SYSTEM. ENGINEER'S SEAL DOES NOT CERTIFY DIMENSIONAL ACCURACY OR ARCHITECTURAL LAYOUT INCLUDING ROOF SYSTEM. ALL REQUIREMENTS FOR PROFESSIONAL CERTIFICATION SHALL BE PROVIDED BY THE APPROPRIATE PROFESSIONAL. SOUTHERN ENGINEERS, P.A. CERTIFIES ONLY THE STRUCTURAL COMPONENTS AS SPECIFICALLY STATED.
- ALL CONSTRUCTION SHALL CONFORM TO THE LATEST REQUIREMENTS OF THE 2018 NC RESIDENTIAL CODE, PLUS ALL LOCAL CODES AND REGULATIONS. THE STRUCTURAL ENGINEER IS NOT RESPONSIBLE FOR, AND WILL NOT HAVE CONTROL OF, CONSTRUCTION MEANS, METHODS, TECHNIQUES, SEQUENCES OR PROCEDURES, OR FOR SAFETY PRECAUTIONS AND PROGRAMS IN CONNECTION WITH THE CONSTRUCTION WORK, NOR WILL THE ENGINEER BE RESPONSIBLE FOR THE CONTRACTOR'S FAILURE TO CARRY OUT THE CONSTRUCTION WORK IN ACCORDANCE WITH THE CONTRACT DOCUMENTS. *CONSTRUCTION REVIEW* SERVICES ARE NOT PART OF OUR CONTRACT. ALL MEMBERS SHALL BE FRAMED ANCHORED, TIED AND BRACED IN ACCORDANCE WITH GOOD CONSTRUCTION PRACTICE AND THE BUILDING CODE.
- DESIGN LOADS (LISTED AS: LIVE LOAD, DEAD LOAD, DEFLECTION)
 - ROOMS OTHER THAN SLEEPING ROOMS: (40 PSF, 10 PSF, L/360)
 - SLEEPING ROOMS: (30 PSF, 10 PSF, L/360)
 - ATTIC WITH PERMANENT STAIR: (40 PSF, 10 PSF, L/360)
 - ATTIC WITHOUT PERMANENT STAIR: (20 PSF, 10 PSF, L/360)
 - ATTIC WITHOUT STORAGE: (10 PSF, 10 PSF, L/240)
 - STAIRS: (40 PSF, 10 PSF, L/360)
 - EXTERIOR BALCONIES: (60 PSF, 10 PSF, L/360)
 - DECKS: (40 PSF, 10 PSF, L/360)
 - GUARDRAILS AND HANDRAILS: (200 LBS)
 - PASSENGER VEHICLE GARAGES: (50 PSF, 10 PSF, L/360)
 - FIRE ESCAPES: (40 PSF, 10 PSF, L/360)
 - SNOW: (20 PSF)
- WALLS SHALL BE BRACED BY SHEATHING WALLS ON ALL STORIES WITH WOOD STRUCTURAL PANELS. SEE FRAMING NOTES FOR THICKNESS AND NAILING REQUIREMENTS.
- SEE APPENDIX M (DCA6) FOR EXTERIOR DECK REQUIREMENTS INCLUDING ATTACHMENTS FOR LATERAL LOADS.
- CONCRETE SHALL HAVE A MINIMUM 28 DAY STRENGTH OF 3000 PSI AND A MAXIMUM SLUMP OF 5 INCHES UNLESS NOTED OTHERWISE (UNO). AIR ENTRAINMENT PER TABLE 402.2. ALL CONCRETE SHALL BE PROPORTIONED, MIXED, HANDLED, SAMPLED, TESTED, AND PLACED IN ACCORDANCE WITH ACI STANDARDS. ALL SAMPLES FOR PUMPING SHALL BE TAKEN FROM THE EXIT END OF THE PUMP. CONTROL JOINTS IN SLABS SHALL BE SPACED ON A GRID OF +30 TIMES THE DEPTH (D). CONTROL JOINTS SHALL BE SAWCUT TO A DEPTH OF 1/D. (I.E. 4' CONCRETE SLABS SHALL HAVE 1/4" DEEP CONTROL JOINTS SAWCUT IN SLAB ON A +10'-0" x +10'-0" GRID).
- ALLOWABLE SOIL BEARING PRESSURE ASSUMED TO BE 2000 PSF. THE CONTRACTOR MUST CONTACT A GEOTECHNICAL ENGINEER AND THE STRUCTURAL ENGINEER IF UNSATISFACTORY SUBSURFACE CONDITIONS ARE ENCOUNTERED. THE SURFACE AREA ADJACENT TO THE FOUNDATION WALL SHALL BE PROVIDED WITH ADEQUATE DRAINAGE, AND SHALL BE GRADED SO AS TO DRAIN SURFACE WATER AWAY FROM FOUNDATION WALLS.
- ALL FRAMING LUMBER SHALL BE SYP #2 (Fb = 875 PSI) UNLESS NOTED OTHERWISE (UNO). ALL TREATED LUMBER SHALL BE SYP #2. PLATE MATERIAL MAY BE SYP #3 OR SYP #3 (Fcp/parp) = 425 PSI - MIN).
 - L.V.L. SHALL BE LAMINATED VENEER LUMBER: Fb=2600 PSI, Fv=285 PSI, E=1.9x10⁶ PSI.
 - P.S.L. SHALL BE PARALLEL STRAND LUMBER: Fb=2900 PSI, Fv=290 PSI, E=2.0x10⁶ PSI.
 - L.S.L. SHALL BE LAMINATED STRAND LUMBER: Fb=2250 PSI, Fv=400 PSI, E=1.55x10⁶ PSI. INSTALL ALL CONNECTIONS PER MANUFACTURERS INSTRUCTIONS.
- ALL ROOF TRUSS AND I-JOIST LAYOUTS SHALL BE PREPARED IN ACCORDANCE WITH THE SEALED STRUCTURAL DRAWINGS. TRUSSES AND I-JOISTS SHALL BE INSTALLED ACCORDING TO THE MANUFACTURE'S SPECIFICATIONS. ANY CHANGE IN TRUSS OR I-JOIST LAYOUT SHALL BE COORDINATED WITH SOUTHERN ENGINEERS.
- ALL STRUCTURAL STEEL SHALL BE ASTM A-36. STEEL BEAMS SHALL BE SUPPORTED AT EACH END WITH A MINIMUM BEARING LENGTH OF 3 1/2" INCHES AND FULL FLANGE WIDTH. PROVIDE SOLID BEARING FROM BEAM SUPPORT TO FOUNDATION. BEAMS SHALL BE ATTACHED TO EACH SUPPORT WITH TWO LAG SCREWS (1/2" DIAMETER x 4" LONG). LATERAL SUPPORT IS CONSIDERED ADEQUATE PROVIDING THE JOIST ARE TOE NAILED TO THE SOLE PLATE, AND SOLE PLATE IS NAILED OR BOLTED TO THE BEAM FLANGE @ 48" O.C. ALL STEEL TUBING SHALL BE ASTM A500.
- REBAR SHALL BE DEFORMED STEEL, ASTM#615, GRADE 60. LAP ALL REBAR SPLICES 30 BAR DIAMETERS.
- FLITCH BEAMS SHALL BE BOLTED TOGETHER USING (2) ROWS OF 1/2" DIAMETER BOLTS (ASTM A325) WITH WASHERS PLACED UNDER THE THREADED END OF BOLT. BOLTS SHALL BE SPACED AT 24" O.C. (MAX), AND STAGGERED AT THE TOP AND BOTTOM OF BEAM (2" EDGE DISTANCE), WITH 2 BOLTS LOCATED AT 6" FROM EACH END.
- BRICK LINTELS (WHEN REQUIRED) SHALL BE 3 1/2"x3 1/2"x1/4" STEEL ANGLE FOR UP TO 6'-0" SPAN AND 6"x4"x5/16" STEEL ANGLE WITH 6" LEG VERTICAL FOR SPANS UP TO 9'-0". SEE PLANS FOR SPANS OVER 9'-0". SEE ALSO SECTION RT03.B.3 LINTELS.

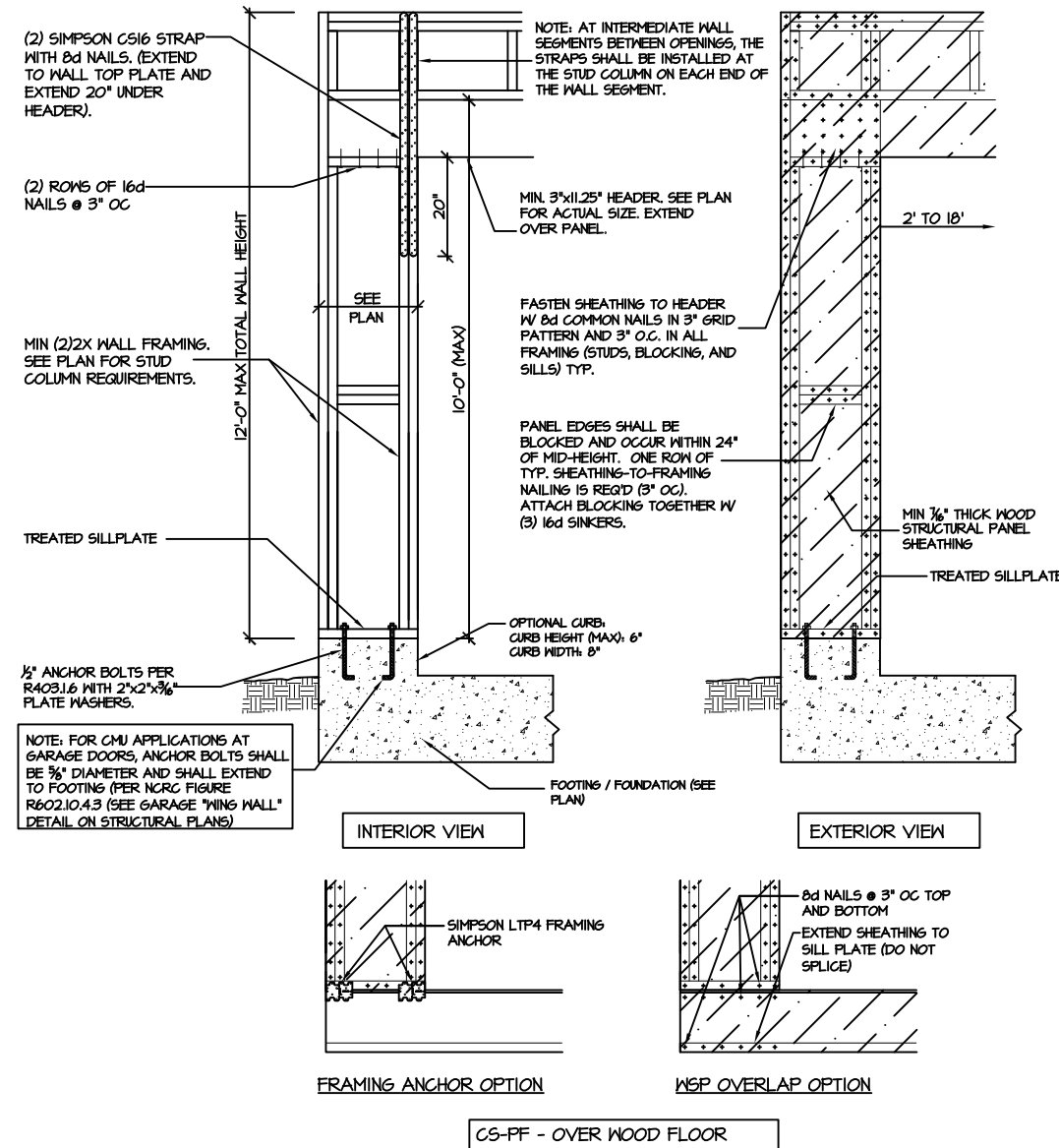

905 CS-PF: CONTINUOUS PORTAL FRAME CONSTRUCTION
SD DETAIL AND APPLICATION BASED ON NCRG FIGURE R602.10.1 - PORTAL FRAME CONSTRUCTION

PROJECT #
22-1192

Engineers seal applies only to structural components on this document. Seal does not include construction means, methods, techniques, sequences, procedures or safety precautions. Any deviations or discrepancies on plans are to be brought to the immediate attention of Southern Engineers. Failure to do so will void Southern Engineer's liability. Seal is valid for projects permitted one year from date of seal. Use of these plans constitutes approval of terms & conditions as defined in the customer agreement.

Southern Engineers, P.A.
3716 Benson Drive, Raleigh, NC 27609
Phone: (919) 878-1617
License: C-4772
www.southernengineers.com

NEW HOME, INC

WILSON

SD