

GRAYSON

BRIARWOOD BLUFF
LOT 0037



PLAN ID 010123

110 VILLAGE TRAIL SUITE 215
WOODSTOCK, GA. 30188

DRAWING INDEX

A0.0	COVER SHEET
A1.1	FRONT ELEVATIONS
A2.1	SIDE & REAR ELEVATIONS
A3.1	SLAB FOUNDATION
A5.1	FIRST FLOOR PLANS & DETAILS
A5.2	SECOND FLOOR PLANS & DETAILS
A6.1	ROOF PLANS
A7.2-A7.3	ELECTRICAL PLANS
A8.1	TRIM LOCATION LAYOUTS

AREA TABULATION

FIRST FLOOR	716
SECOND FLOOR	780
TOTAL	1496
GARAGE	418
FRONT PORCH (COVERED)	62
REAR PATIO	120

PLAN REVISIONS

DATE	BY	REVISION	PAGE #
5/30/2023	AW	Prototype walk revisions - see revision sheet	A3.1, A5.1, A5.2, A7.2, A7.3, A8.1
1/24/2024	AW	Added optional side entry	ALL

GOVERNMENTAL CODES & STANDARDS

HOME TO BE BUILT TO CONFORM TO ALL APPLICABLE LOCAL CODES, PRACTICES AND STANDARDS

BUILDING CODE ANALYSIS / DESIGN CRITERIA

HOME TO BE BUILT TO MEET OR EXCEED ALL LOCAL CODES AND DESIGN CRITERIA

ALL NON-MASONRY RETURNS TO BE HORIZONTAL SIDING

SEE SHEET D3 OF SDH TYPICAL DETAILS FOR SOFFIT DETAILS PER SOFFIT MATERIAL

BRIARWOOD BLUFF LOT 0037

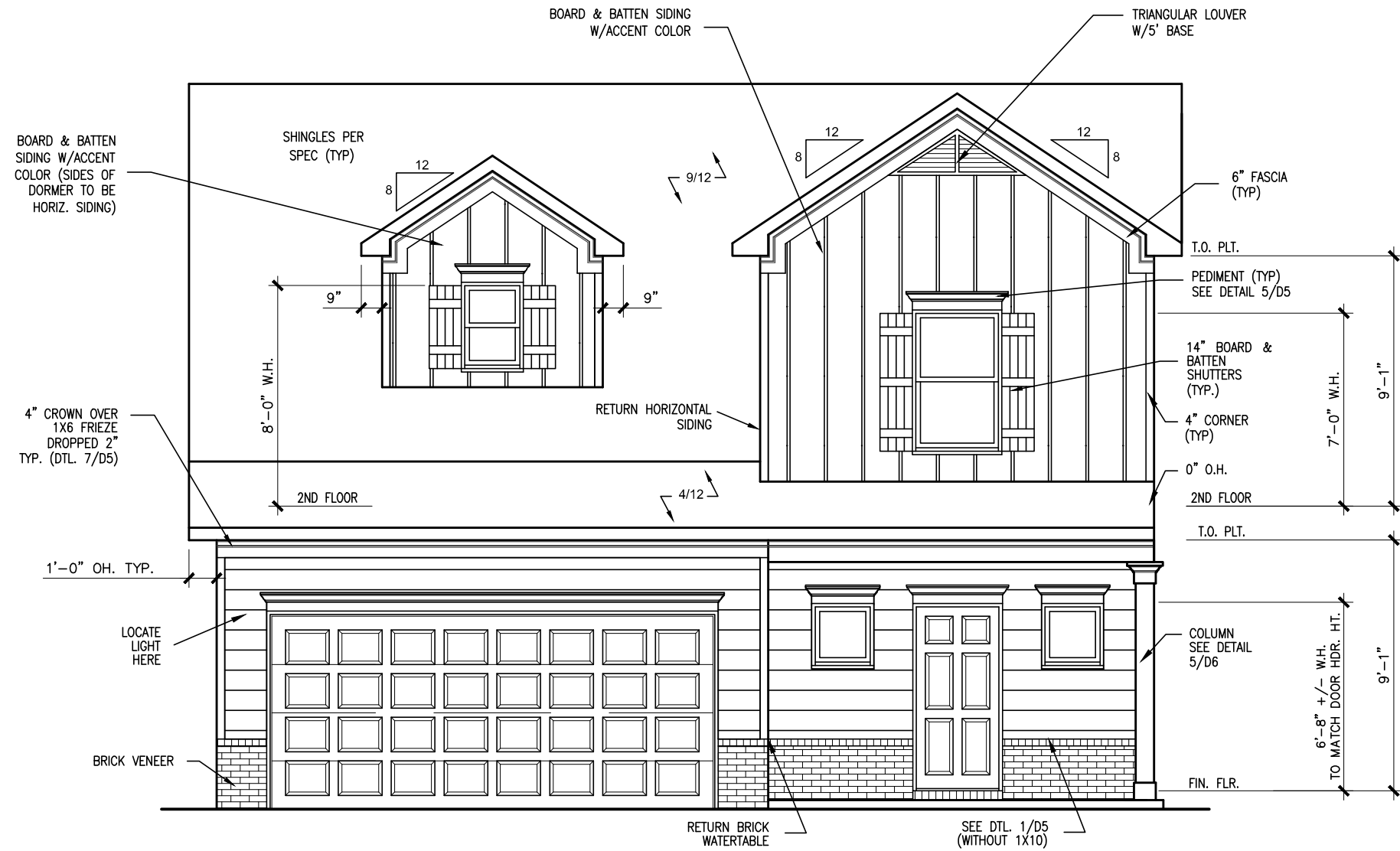

FRONT ELEVATION "B"

SCALE: 3/16"=1'-0"

BY	REVISION	DATE
#	#	#
#	#	#
#	#	#
#	#	#
#	#	#



ELEVATIONS
FRONT ELEVATION
GRAYSON

SMITH DOUGLAS HOMES
110 VILLAGE TRAIL
SUITE 115
WOODSTOCK, GA 30188
www.smithdouglas.com

SMITH DOUGLAS HOMES expressly reserves its property rights in these plans and drawings. These plans and related drawings are not to be reproduced without written consent from SMITH DOUGLAS HOMES.

BY: KCC	CH: AW
DATE: 6/5/2024	
FACADE OPT: B	
PLAN ID:	
FND: ALL	ELEV: B
PAGE NO: A1.1	

BRIARWOOD BLUFF LOT 0037

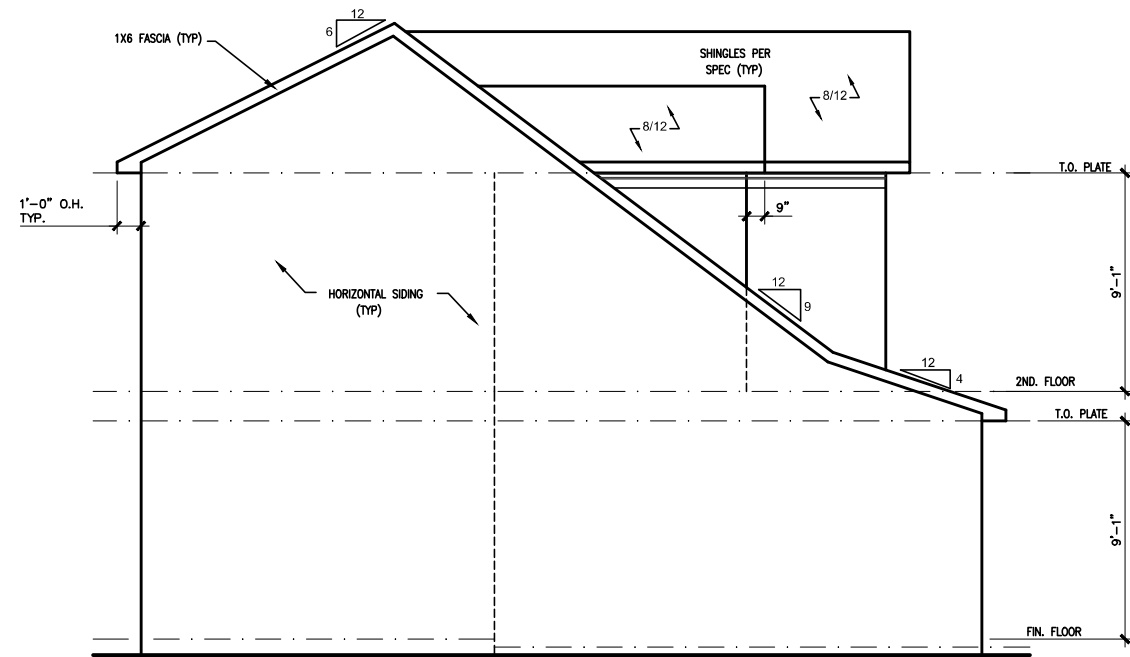

LEFT ELEVATION "B"

SCALE: 1/8" = 1'-0"

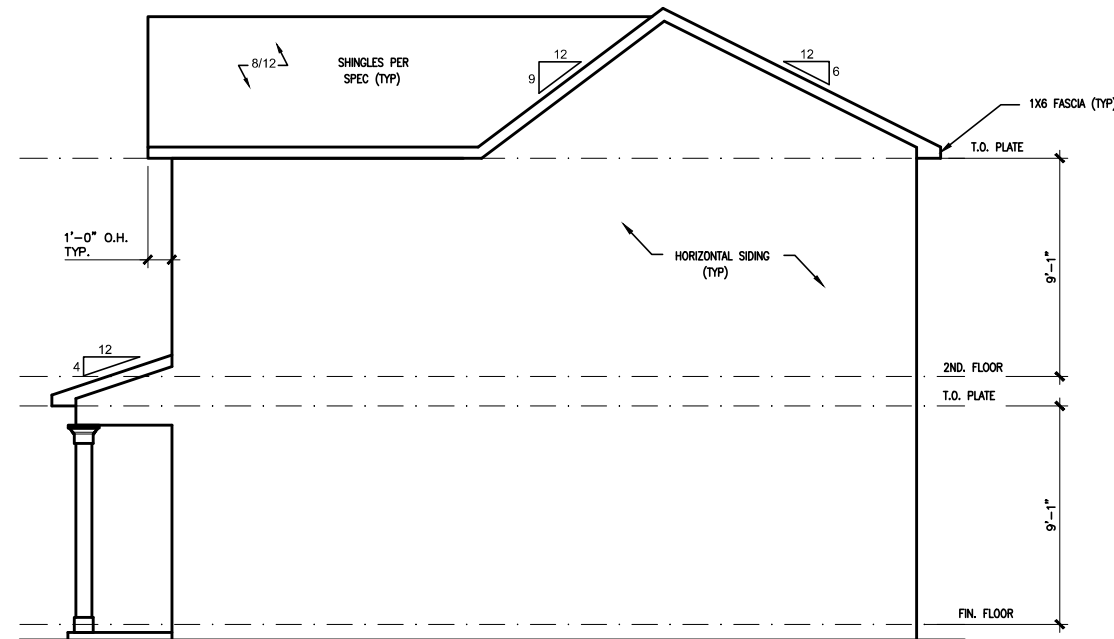

RIGHT ELEVATION "B"

SCALE: 1/8" = 1'-0"

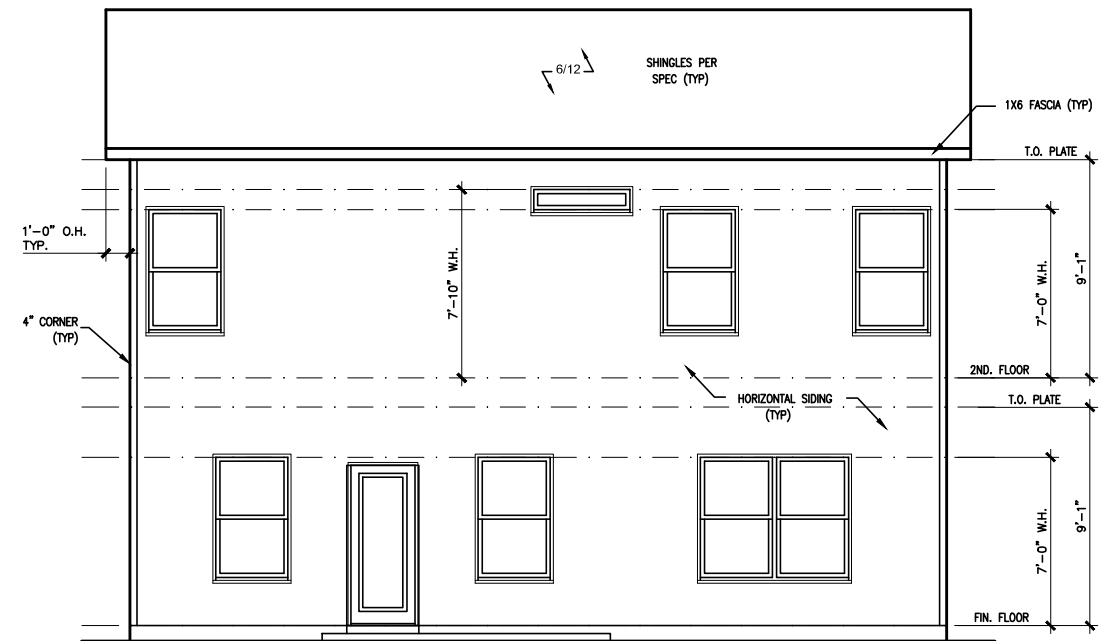

REAR ELEVATION "B"

SCALE: 1/8" = 1'-0"

REV.	BY	DATE	REVISION



ELEVATIONS
SIDES AND REAR
GRAYSON

SMITH DOUGLAS HOMES
110 VILLAGE TRAIL
SUITE 115
WOODSTOCK, GA 30188
www.smithdouglashomes.com

SMITH DOUGLAS HOMES expressly reserves its property rights in these plans and drawings. These plans and related drawings are not to be reproduced without written consent from SMITH DOUGLAS HOMES.

BY: KCC	CH: AW
DATE: 6/5/2024	
FACADE OPT: B	
PLAN ID:	
FND: ALL	ELEV: B
PAGE NO: A2.1	

BRIARWOOD BLUFF LOT 0037

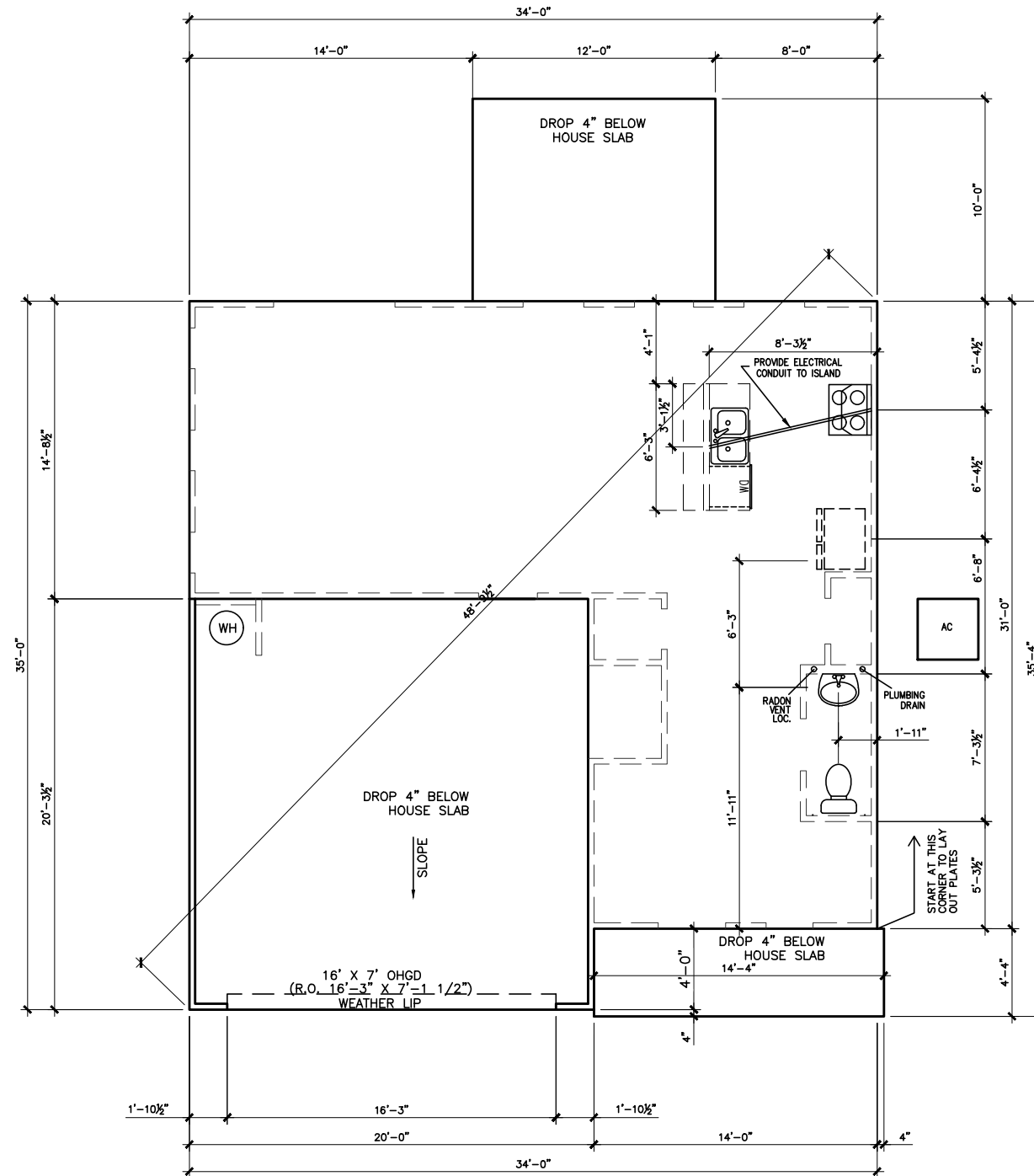

*RADON VENT PROVIDED
PER LOCAL CODE

REFER TO DETAIL 3/D1
FOR BRICK LEDGE
DETAIL WHEN BRICK
VENEER IS CHOSEN

SLAB PLAN

SCALE: 1/8" = 1'-0"

DATE	REVISION	BY
#	#	#
#	#	#
#	#	#
#	#	#
#	#	#



FOUNDATION PLAN
SLAB PLAN
GRAYSON

SMITH DOUGLAS HOMES
110 VILLAGE TRAIL
SUITE 115
WOODSTOCK, GA 30188
www.smithdouglas.com

SMITH DOUGLAS HOMES
expressly reserves its
property rights in these
plans and drawings.
These plans and related
drawings are not to be
reproduced without written
consent from SMITH
DOUGLAS HOMES.

BY: KCC	CH: AW
DATE: 6/5/2024	
FACADE OPT: B	
PLAN ID:	
FND: ALL	ELEV: B
PAGE NO: A3.1	

BRIARWOOD BLUFF LOT 0037

BY	REVISION	DATE

SMITH DOUGLAS HOMES
QUALITY | INTEGRITY | VALUE

FLOOR PLAN
FIRST FLOOR
GRAYSON

SMITH DOUGLAS HOMES
110 VILLAGE TRAIL
SUITE 115
WOODSTOCK, GA 30188
www.smithdouglas.com

SMITH DOUGLAS HOMES expressly reserves its property rights in these plans and drawings. These plans and related drawings are not to be reproduced without written consent from SMITH DOUGLAS HOMES.

BY: KCC	CH: AW
DATE: 6/5/2024	
FACADE OPT: B	
PLAN ID:	
FRONT: ALL	ELEV: B
PAGE NO: A5.1	

*RADON VENT PROVIDED PER LOCAL CODE

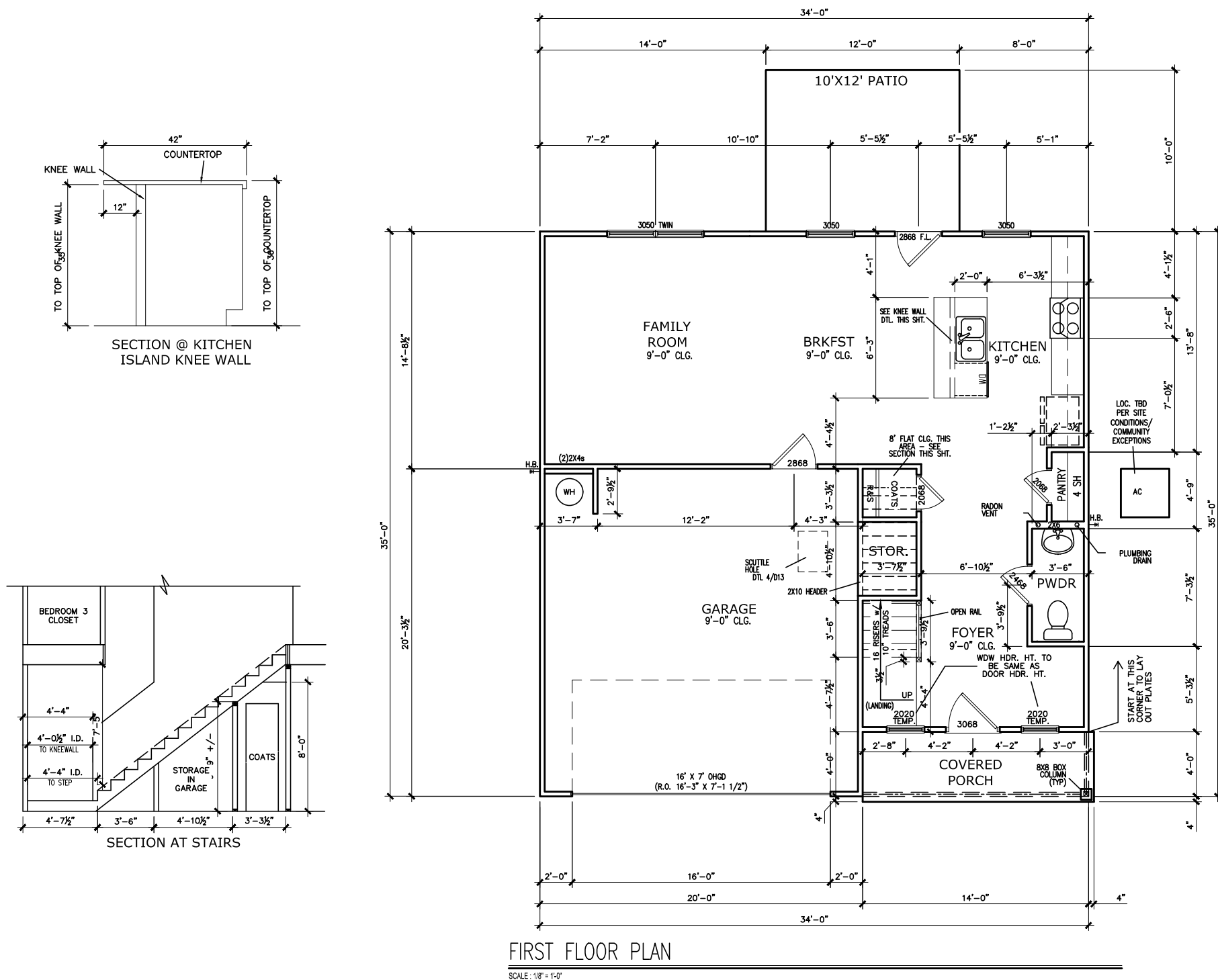

BRIARWOOD BLUFF LOT 0037

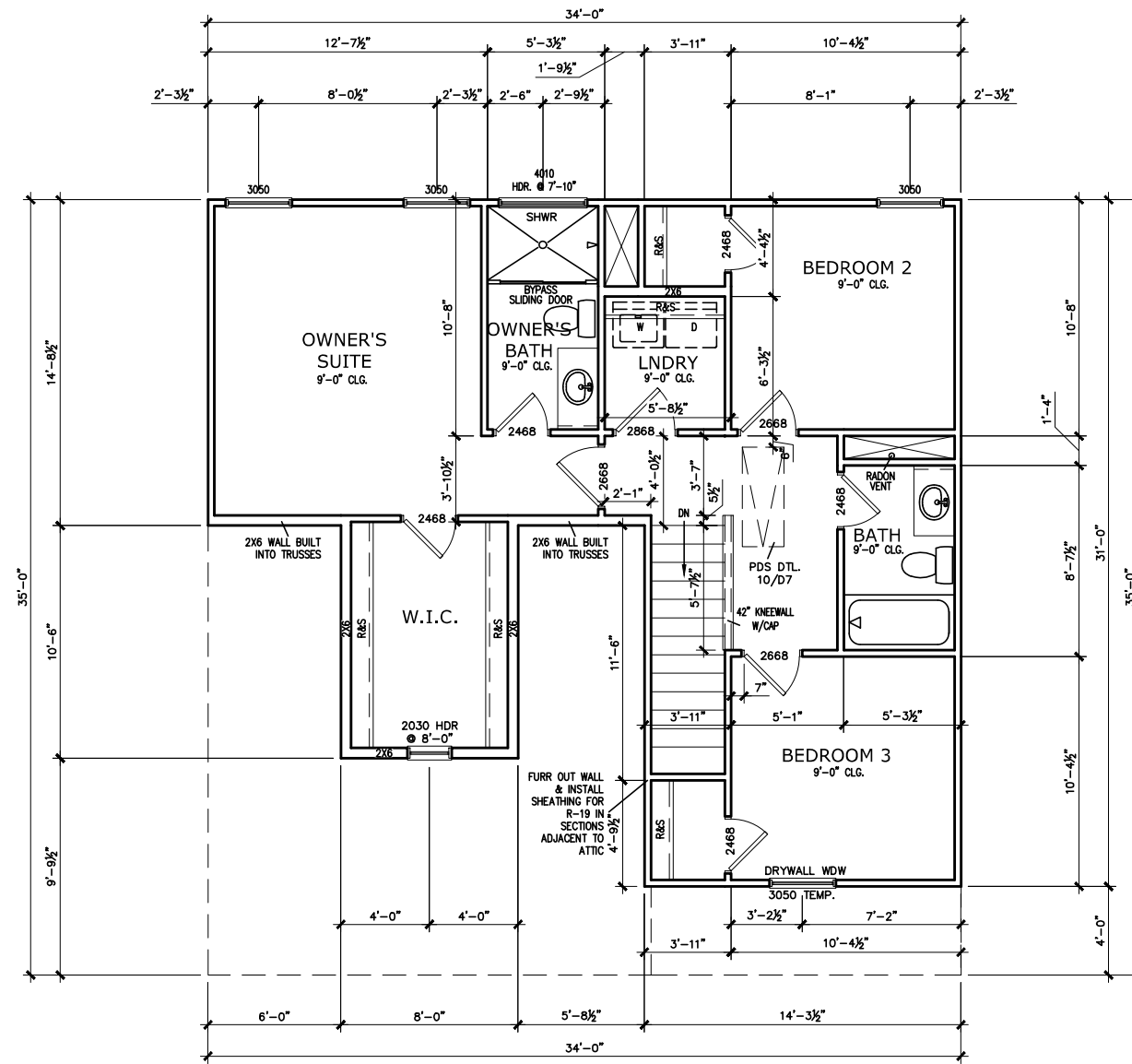

SECOND FLOOR PLAN

SCALE: 1/8" = 1'-0"

*RADON VENT PROVIDED
PER LOCAL CODE

REFER TO MANUFACTURER'S SPECS.
FOR DRAIN LOCATIONS ON DETAIL
SHEETS D12, D12.1, & D12.2

DATE	REVISION	BY



FLOOR PLAN
SECOND FLOOR
GRAYSON

SMITH DOUGLAS HOMES
110 VILLAGE TRAIL
SUITE 115
WOODSTOCK, GA 30188
www.smithdouglas.com

SMITH DOUGLAS HOMES
expressly reserves its
property rights in these
plans and drawings.
These plans and related
drawings are not to be
reproduced without written
consent from SMITH
DOUGLAS HOMES.

BY: KCC	CH: AW
DATE: 6/5/2024	
FACADE OPT: B	
PLAN ID:	
FND: ALL	ELEV: B
PAGE NO: A5.2	

BRIARWOOD BLUFF LOT 0037

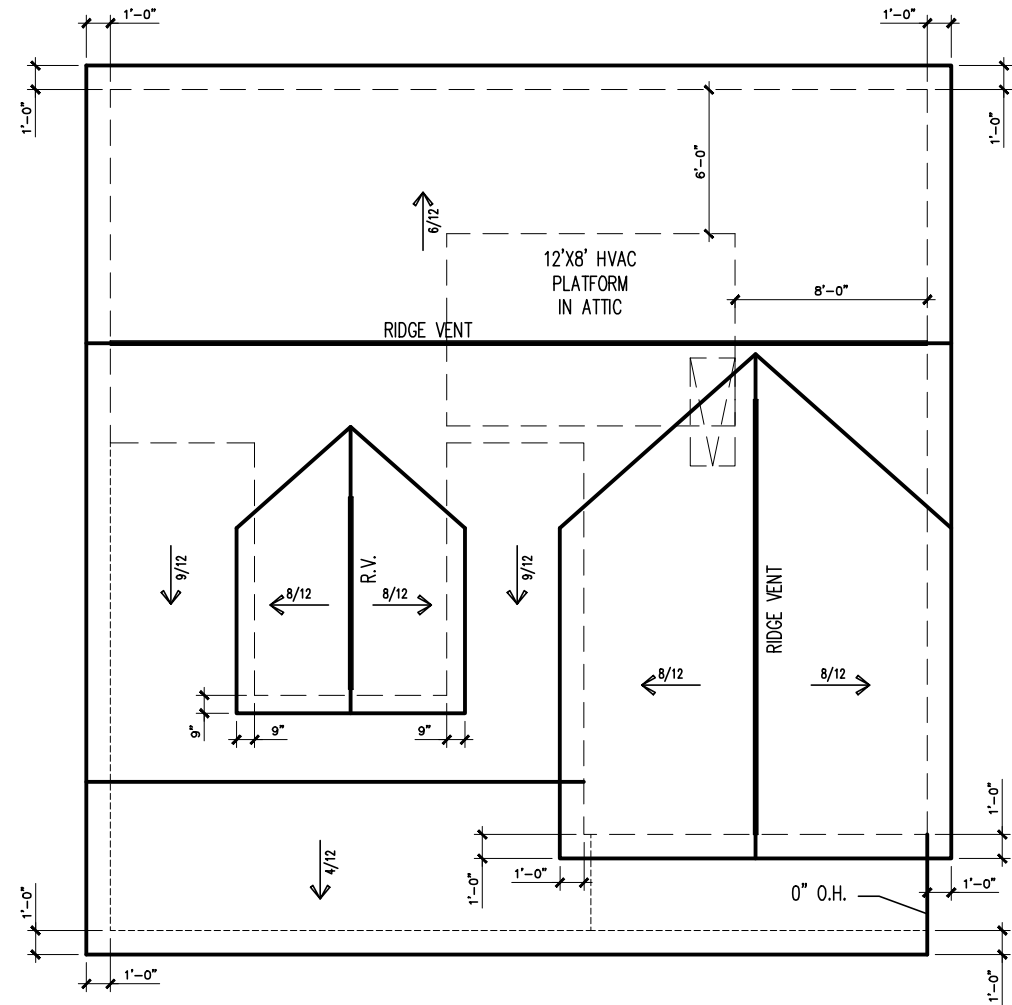

ROOF LAYOUT "B"
SCALE : 1/8" = 1'-0"

DATE	REVISION	BY
#	#	#
#	#	#
#	#	#
#	#	#
#	#	#



ROOF PLAN
ROOF PLAN
GRAYSON

SMITH DOUGLAS HOMES
110 VILLAGE TRAIL
SUITE 115
WOODSTOCK, GA 30188
www.smithdouglas.com

SMITH DOUGLAS HOMES expressly reserves its property rights in these plans and drawings. These plans and related drawings are not to be reproduced without written consent from SMITH DOUGLAS HOMES.

BY: KCC	CH: AW
DATE: 6/5/2024	
FACADE OPT: B	
PLAN ID:	
FND: ALL	ELEV: B
PAGE NO: A6.1	

BRIARWOOD BLUFF LOT 0037

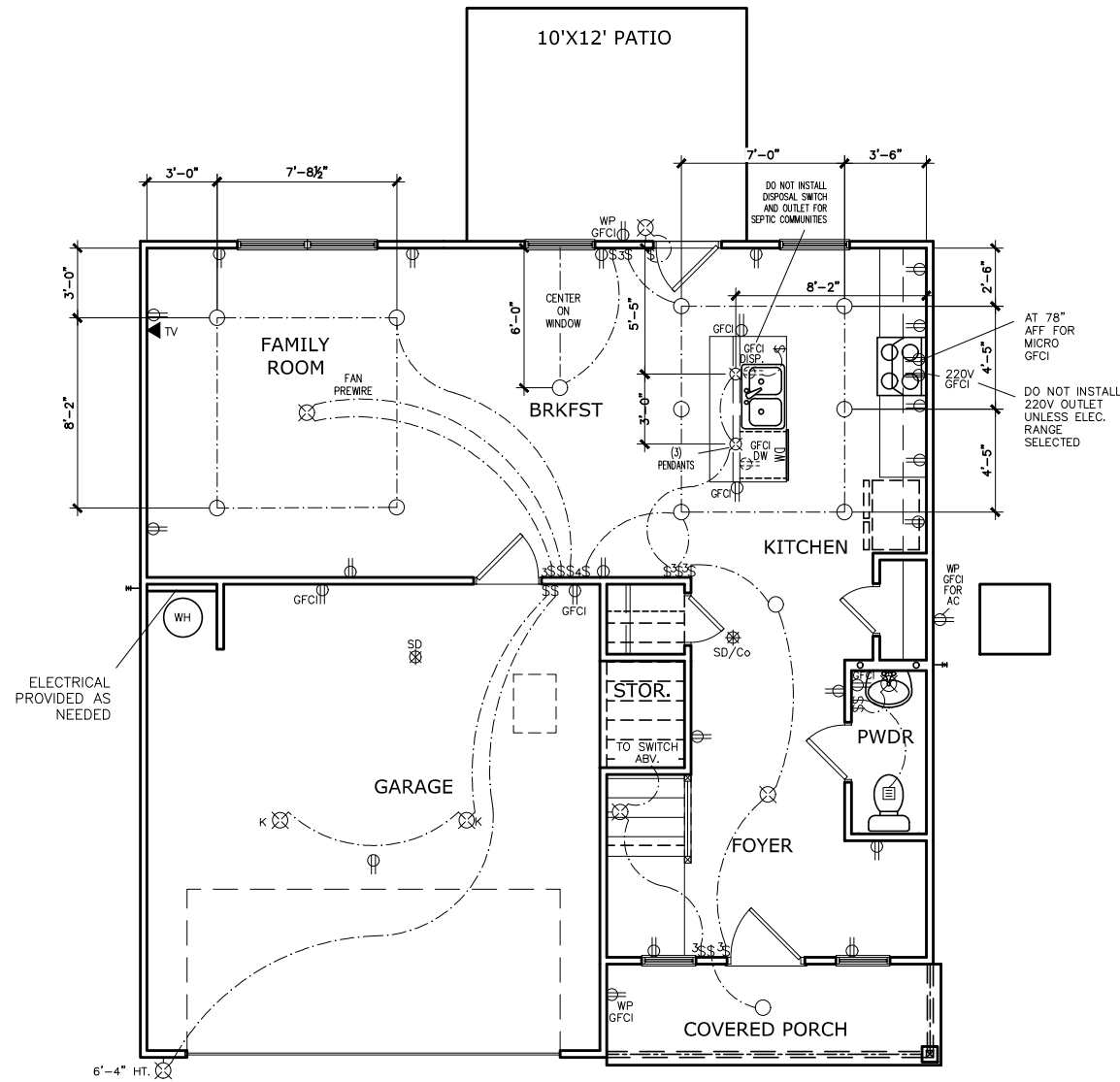

FIRST FLOOR ELECTRICAL PLAN

SCALE: 1/8" = 1'-0"

ELECTRICAL LEGEND			
\$	SWITCH	TV	TV
\$3	3 WAY SWITCH	⊕	120V RECEPTACLE
\$4	4 WAY SWITCH	⊕	120V SWITCHED RECEPTACLE
⊗	CEILING FIXTURE	⊕	220V RECEPTACLE
⊕	KEYLESS	⊕	GFCI OUTLET
⊕	WALL MOUNT FIXTURE	⊕	ARCH FAULT CIRCUIT INTERRUPTER
⊕	CEILING FIXTURE	†	GAS LINE
⊕	FLEX CONDUIT	†	WATER LINE
CH	CHIMES	⊕	HOSE BIBB
PH	TELEPHONE	⊕	FLOOD LIGHT
SD/Co	SMOKE DETECTOR & CARBON MONOXIDE	⊕	1x4 LUMINOUS FIXTURE
SO	SECURITY OUTLET	⊕	CEILING FAN
□	GARAGE DOOR OPENER	—	ELECTRICAL WIRING
⊕	EXHAUST FAN	⊕	CEILING FIXTURE
⊕	FAN/LIGHT		
ELECTRICAL PLANS TO FOLLOW ALL LOCAL CODES			
APPROX. FIXTURE HGTS (MEASURED FROM BOTTOM OF FIXTURE)			
BREAKFAST/DINING ROOM	63" ABOVE FINISHED FLOOR		
KITCHEN PENDANT LIGHTS	33" ABOVE COUNTER TOP		
TWO STORY FOYER FIXTURE	96" ABOVE FINISHED FLOOR		
CEILING FAN	96" ABOVE FINISHED FLOOR		
FLOOD LIGHT	10' MAX. ABOVE FIN. FLOOR		

NOTE: FINAL PLACEMENT OF PHONE/CABLE T.B.D. ON SITE BY THE BUILDER

BY	REVISION	#	#	#	#	#
DATE						

SMITH DOUGLAS HOMES
QUALITY | INTEGRITY | VALUE

ELECTRICAL PLAN
FIRST FLOOR
GRAYSON

SMITH DOUGLAS HOMES
110 VILLAGE TRAIL
SUITE 115
WOODSTOCK, GA 30188
www.smithdouglas.com

SMITH DOUGLAS HOMES expressly reserves its property rights in these plans and drawings. These plans and related drawings are not to be reproduced without written consent from SMITH DOUGLAS HOMES.

BY: KCC	CH: AW
DATE: 6/5/2024	
FACADE OPT: B	
PLAN ID:	
FND: ALL	BLV: B
PAGE NO: A7.2	

BRIARWOOD BLUFF LOT 0037

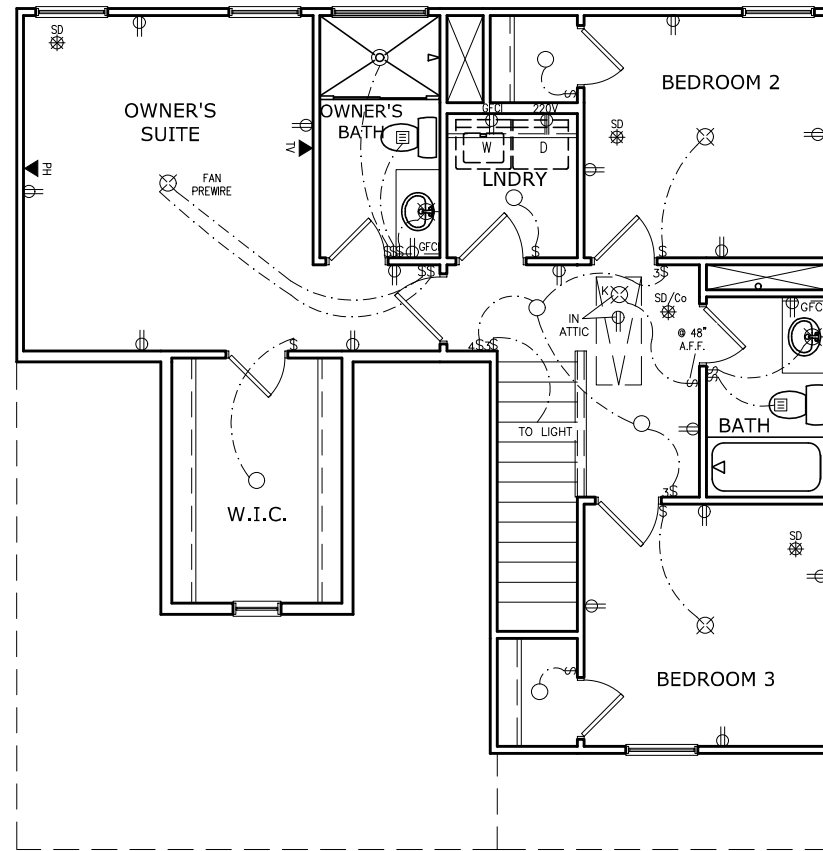

SECOND FLOOR ELECTRICAL PLAN

SCALE: 1/8" = 1'-0"

ELECTRICAL LEGEND			
S	SWITCH	TV	TV
S3	3 WAY SWITCH	⊕	120V RECEPTACLE
S4	4 WAY SWITCH	⊕	120V SWITCHED RECEPTACLE
⊗	CEILING FIXTURE	⊕	220V RECEPTACLE
⊕	KEYLESS	⊕	GFCI OUTLET
H	WALL MOUNT FIXTURE	⊕	ARCH FAULT CIRCUIT INTERRUPTER
○	CEILING FIXTURE	†	GAS LINE
●	FLEX CONDUIT	†	WATER LINE
CH	CHIMES	⊥	HOSE BIBB
PH	TELEPHONE	⊕	FLOOD LIGHT
SD/Co	SMOKE DETECTOR & CARBON MONOXIDE	⊕	1x4 LUMINOUS FIXTURE
SO	SECURITY OUTLET	⊕	CEILING FAN
□	GARAGE DOOR OPENER	⊕	ELECTRICAL WIRING
⊕	EXHAUST FAN	⊕	CEILING FIXTURE
⊕	FAN/LIGHT		
ELECTRICAL PLANS TO FOLLOW ALL LOCAL CODES			
APPROX. FIXTURE HGTS (MEASURED FROM BOTTOM OF FIXTURE)			
BREAKFAST/DINING ROOM	63" ABOVE FINISHED FLOOR		
KITCHEN PENDANT LIGHTS	33" ABOVE COUNTER TOP		
TWO STORY FOYER FIXTURE	96" ABOVE FINISHED FLOOR		
CEILING FAN	96" ABOVE FINISHED FLOOR		
FLOOD LIGHT	10' MAX. ABOVE FIN. FLOOR		

NOTE: FINAL PLACEMENT OF PHONE/CABLE T.B.D. ON SITE BY THE BUILDER

DATE	REVISION	BY



ELECTRICAL PLAN
SECOND FLOOR
GRAYSON

SMITH DOUGLAS HOMES
110 VILLAGE TRAIL
SUITE 115
WOODSTOCK, GA 30188
www.smithdouglas.com

SMITH DOUGLAS HOMES expressly reserves its property rights in these plans and drawings. These plans and related drawings are not to be reproduced without written consent from SMITH DOUGLAS HOMES.

BY: KCC	CH: AW
DATE: 6/5/2024	
FACADE OPT: B	
PLAN ID:	
FND: ALL	BLV: B
PAGE NO: A7.3	

BRIARWOOD BLUFF LOT 0037

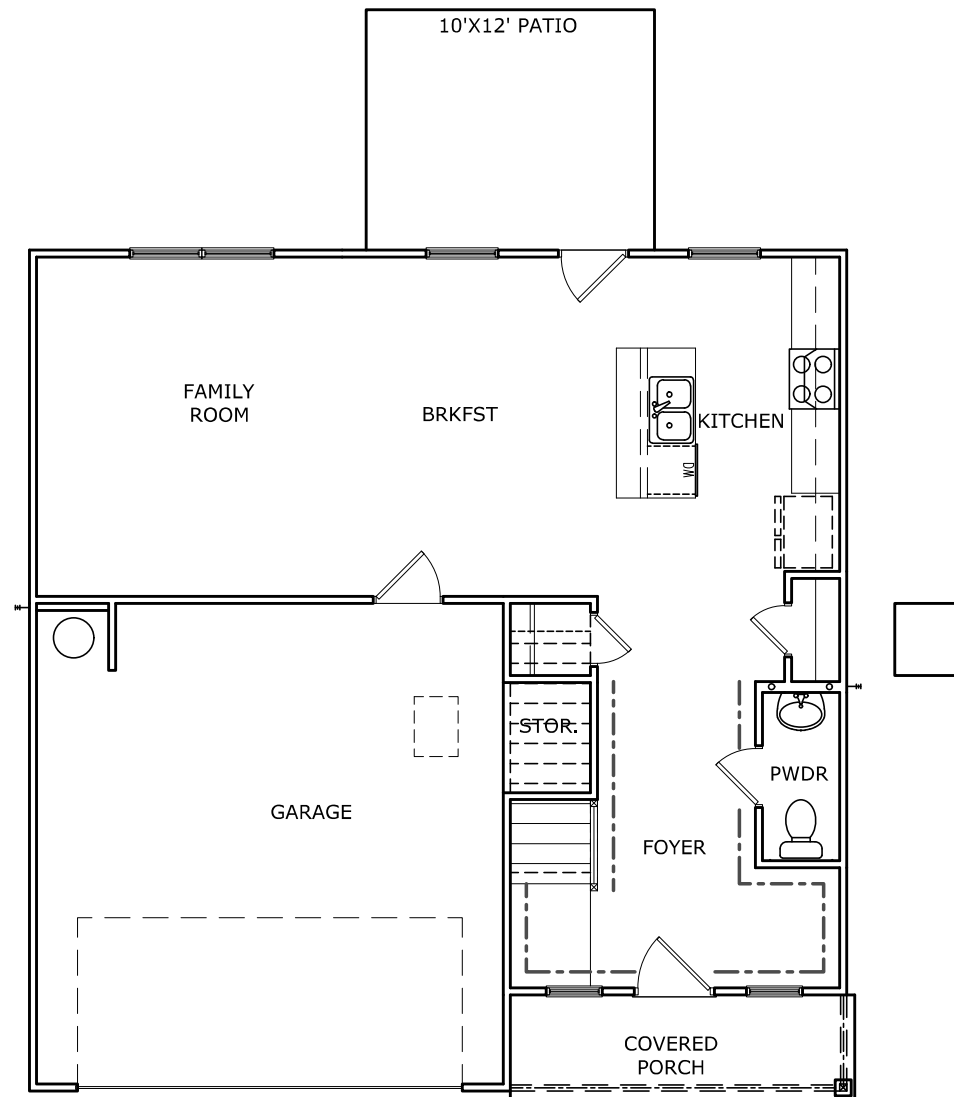

FOYER TRIM - CHAIR/SHADOW - - - - -

TRIM LAYOUT FIRST FLOOR PLAN

SCALE : 1/8" = 1'-0"

DATE	REVISION	BY
#	#	#
#	#	#
#	#	#
#	#	#
#	#	#



FLOOR PLAN
TRIM LAYOUT
GRAYSON

SMITH DOUGLAS HOMES
110 VILLAGE TRAIL
SUITE 115
WOODSTOCK, GA 30188
www.smithdouglas.com

SMITH DOUGLAS HOMES expressly reserves its property rights in these plans and drawings. These plans and related drawings are not to be reproduced without written consent from SMITH DOUGLAS HOMES.

BY: KCC	CH: AW
DATE: 6/5/2024	
FACADE OPT: B	
PLAN ID:	
FND: ALL	ELEV: B
PAGE NO: A8.1	

REFER TO LOT SPECIFIC PLAN TO DETERMINE WHICH DETAILS APPLY

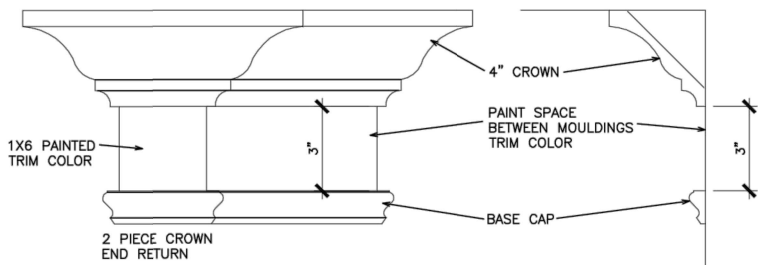

TYPICAL TWO PIECE CROWN

N.T.S.

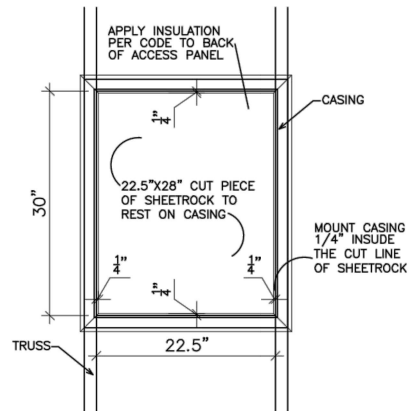

SCUTTLE HOLE DETAIL

N.T.S.

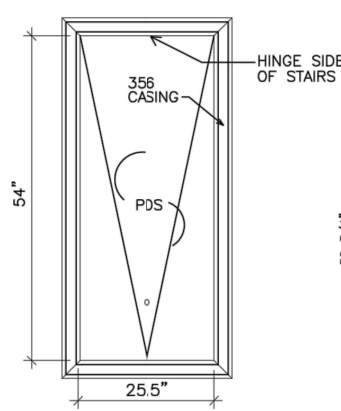

PDS TRIM DETAIL

N.T.S.

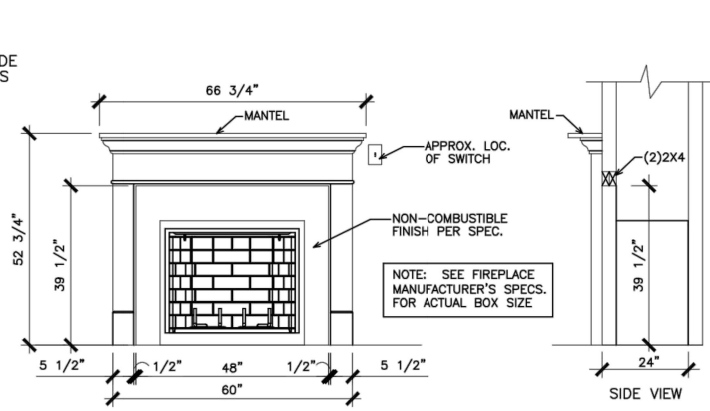

GAS/ELECTRIC FIREPLACE DETAIL WITH WESCOTT WOOD MANTEL

N.T.S.

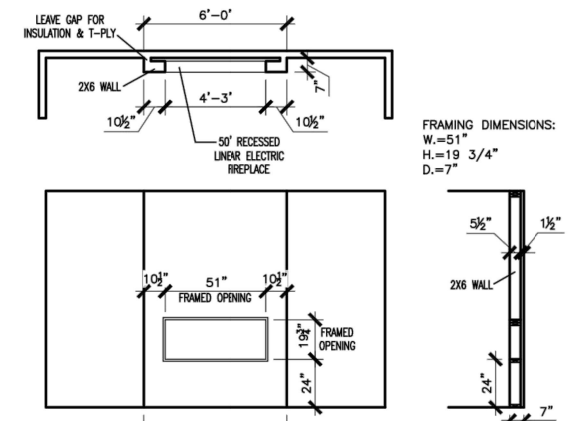

LINEAR ELECTRIC FIREPLACE DETAIL

N.T.S.

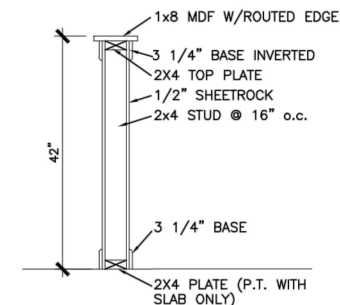

TYP. KNEEWALL SECTION

N.T.S.

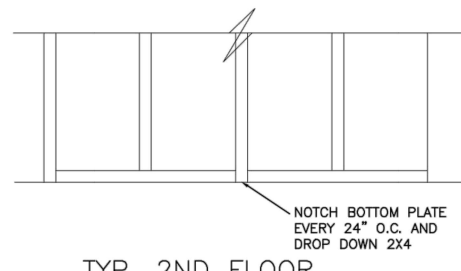

TYP. 2ND FLOOR KNEEWALL STABILITY

N.T.S.

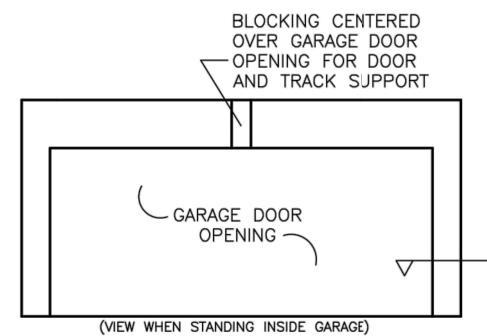

TYP. GARAGE WRAP & BLOCKING

N.T.S.

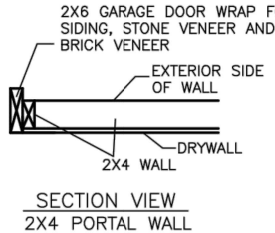

SECTION VIEW 2X4 PORTAL WALL

N.T.S.

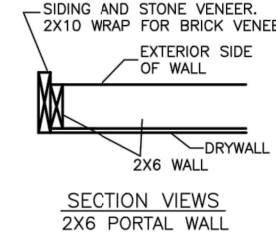

SECTION VIEWS 2X6 PORTAL WALL

N.T.S.

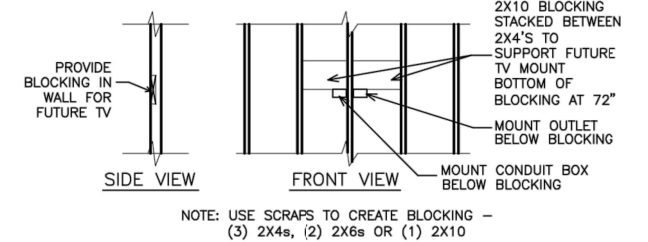

TYP. TV WALL PREP

N.T.S.

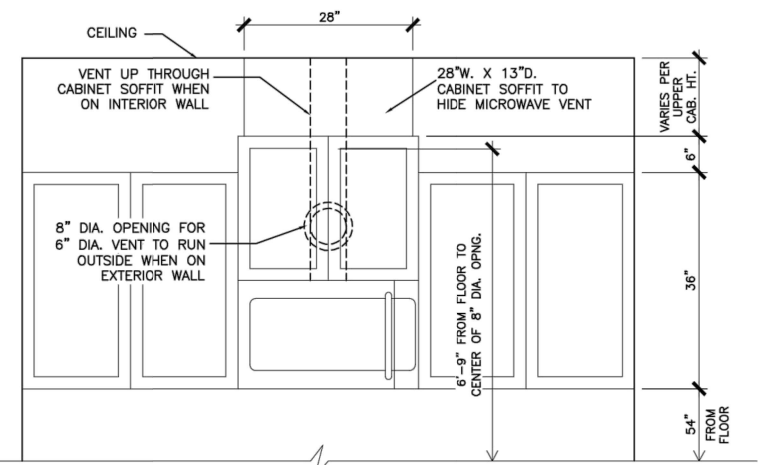

CABINET SOFFIT DETAIL ABOVE VENTED MICROWAVE W/CABINET ABOVE RANGE BUMPED UP & OUT

N.T.S.

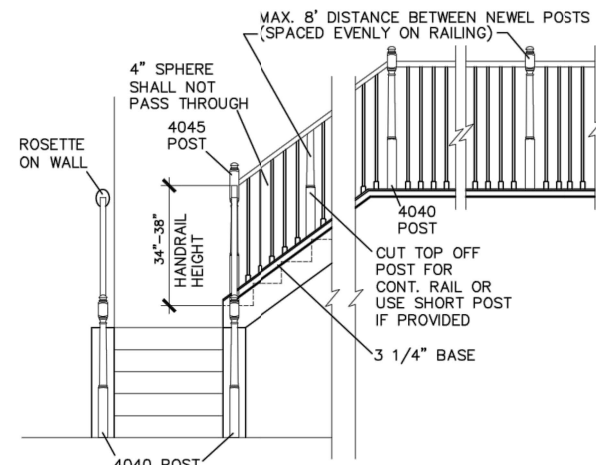

HANDRAIL/POST DETAIL @ STAIRS

N.T.S.

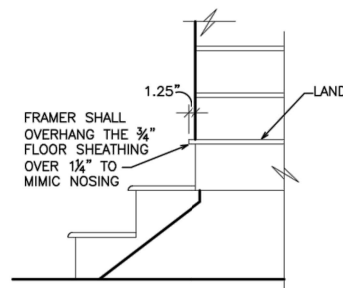

BOX STEP OVERHANG

N.T.S.

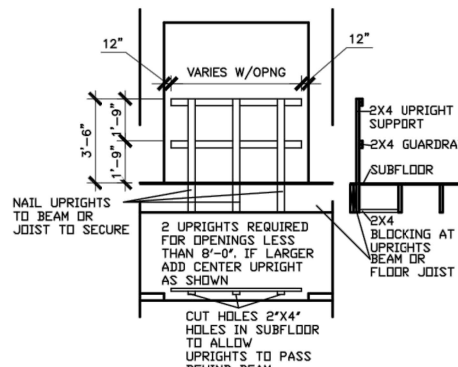

GUARD RAIL DTL. AS REQ'D

N.T.S.

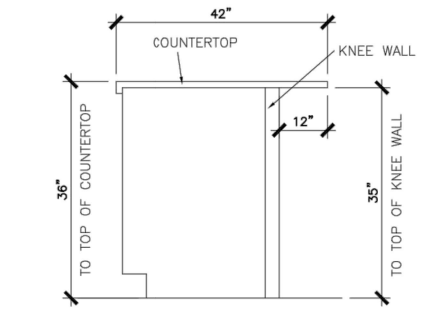

SECTION @ ISLAND KNEEWALL

N.T.S.

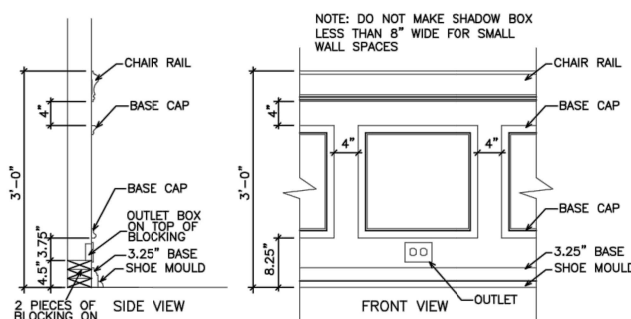

TYPICAL CHAIR RAIL & SHADOW BOX DETAIL

N.T.S.

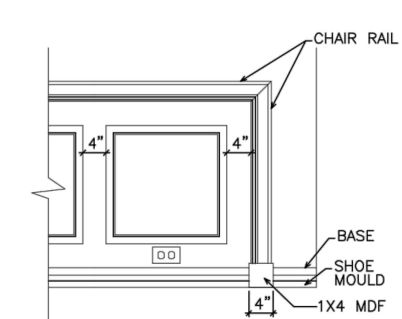

CHAIR RAIL END TRIM DETAIL

N.T.S.

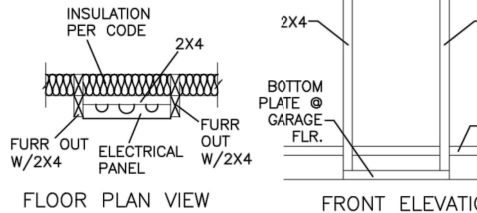

ELECTRICAL PANEL DETAIL

N.T.S.

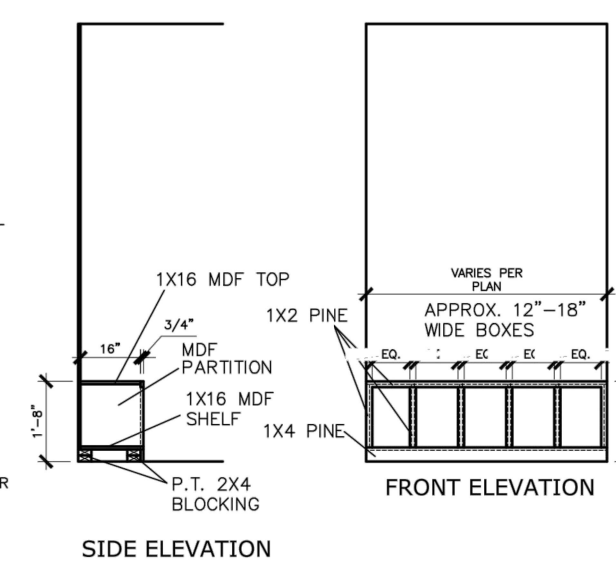

MUD ROOM BENCH SEAT DETAIL

N.T.S.

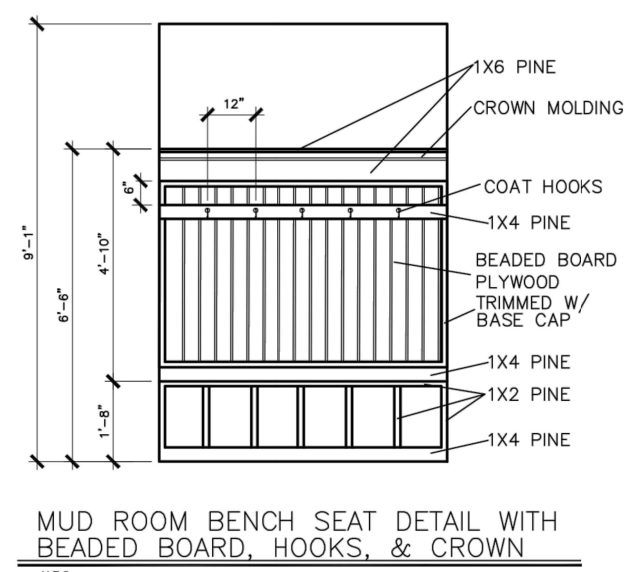

MUD ROOM BENCH SEAT DETAIL WITH BEADED BOARD, HOOKS, & CROWN

N.T.S.

(IF TRIM CHOSEN WITHOUT BENCH CONTINUE TO FLOOR)

© SMITH DOUGLAS HOMES 2023

BY	REVISION	DATE

SMITH DOUGLAS HOMES
QUALITY | INTEGRITY | VALUE

INTERIOR TRIM
DETAILS

SMITH DOUGLAS HOMES
110 VILLAGE TRAIL
SUITE 215
WOODSTOCK, GA 30188
www.smithdouglas.com

SMITH DOUGLAS HOMES expressly reserves its property rights in these plans and drawings. These plans and related drawings are not to be reproduced without written consent from SMITH DOUGLAS HOMES.

DATE:	6/13/23
PLAN ID:	
PND:	
ELEV:	
PAGE NO.:	D1.1

CONNECTION SPECIFICATIONS (TYP. U.N.O.)		
DESCRIPTION OF BLDG. ELEMENT	3"x0.131" NAILS	3"x0.120" NAILS
JOIST TO SOLE PLATE	(3) TOENAILS NAILS @ 4" o.c.	(3) TOENAILS* NAILS @ 4" o.c.
SOLE PL. TO JOIST/RIM OR BLK'G STUD TO PLATE	(4) TOENAILS/ (3) END NAILS	(4) TOENAILS/ (4) END NAILS*
RIM TO TOP PLATE	TOENAILS @ 6" o.c.	TOENAILS @ 4" o.c.*
BLK'G. BTWN. JOISTS TO TOP PL.	(3) TOENAILS EA. END	(3) TOENAILS EA. END*
DOUBLE STUD	NAILS @ 16" o.c.	NAILS @ 16" o.c.
DOUBLE TOP PLATE	NAILS @ 12" o.c.	NAILS @ 8" o.c.
DOUBLE TOP PLATE LAP SPLICE	(12) NAILS IN LAPPED AREA (24" MIN.)	(15) NAILS IN LAPPED AREA (24" MIN.)
TOP PLATE LAP @ CORNERS & INTERSECTING WALLS	(3) NAILS	(3) NAILS
RAFTER/TRUSS TO TOP PLATE	(4) TOENAILS + (1) SIMPSON H25T TOENAILS @ 8" o.c.	(4) TOENAILS + (1) SIMPSON H25T TOENAILS @ 6" o.c.
GAB. END TRUSS TO DBL. TOP PL.	2x10 BLK EVERY 3RD BAY FASTENED TO DBL. TOP PLATE w/ TOENAILS @ 6" o.c.	2x10 BLK EVERY 3RD BAY FASTENED TO DBL. TOP PLATE w/ TOENAILS @ 4" o.c.
R.T. w/ HEEL HT. 9 1/4" TO 12"	2x12 BLK EVERY 3RD BAY FASTENED TO DBL. TOP PLATE w/ TOENAILS @ 6" o.c.	2x12 BLK EVERY 3RD BAY FASTENED TO DBL. TOP PLATE w/ TOENAILS @ 4" o.c.
R.T. w/ HEEL HT. 12" TO 16"	LAP WALL SHTG. w/ DBL. TOP PL. & INSTALL ON TRUSS VERT. - FASTEN w/ NAILS @ 6" o.c.	LAP WALL SHTG. w/ DBL. TOP PL. & INSTALL ON TRUSS VERT. - FASTEN w/ NAILS @ 6" o.c.*
R.T. w/ HEEL HT. UP TO 24"	LAP WALL SHTG. w/ DBL. TOP PL. & INSTALL ON TRUSS VERT. - FASTEN w/ NAILS @ 6" o.c. PROVIDE 2x BLK @ EA. BAY AT TOP OF HEEL.	LAP WALL SHTG. w/ DBL. TOP PL. & INSTALL ON TRUSS VERT. - FASTEN w/ NAILS @ 6" o.c. PROVIDE 2x BLK @ EA. BAY AT TOP OF HEEL.*
R.T. w/ HEEL HT. 24" TO 48"	WALL SHTG. LAP w/ SILL PL. & FASTENED PER SHEAR WALL FASTENING SPEC.	

* 2 1/2"x0.113 IS AN ACCEPTABLE ALTERNATIVE TO A 3"x0.120", SAME SPACING OR NUMBER OF NAILS. (ONLY ACCEPTABLE WHERE * ARE SHOWN)

ADDITIONAL NOTES FOR TRUSS & I-JOIST MANUFACTURER

ROOF TRUSS AND ENGINEERED JOISTS SHALL BE DESIGNED TO MEET THE DEFLECTION CRITERIA BELOW, UNLESS NOTED OTHERWISE ON PLAN. MULHERN & KULP CANNOT BE HELD RESPONSIBLE FOR ANY STRUCTURAL ISSUES RELATED TO ANY BUILDING COMPONENT IF COMPONENT SHOP DRAWINGS ARE NOT SUBMITTED TO MK FOR REVIEW PRIOR TO FABRICATION, DELIVERY, OR INSTALLATION.

TRUSSES/JOISTS SHALL BE DESIGNED SO THAT DIFFERENTIAL DEFLECTION BETWEEN ADJACENT PARALLEL TRUSSES/JOISTS OR GIRDER TRUSSES/FLUSH BEAMS DO NOT EXCEED THE FOLLOWING:

A. ROOF TRUSSES:
 1/4" DEAD LOAD
 ATTIC TRUSSES, & I-JOISTS:
 1/8" DEAD LOAD

ABSOLUTE DEAD LOAD DEFLECTION OF ATTIC TRUSSES WHEN ADJACENT TO FLOOR FRAMING BY OTHERS SHALL BE LIMITED TO 3/16". (NOT DIFFERENTIAL DEFLECTION)

VENEER LINTEL SCHEDULE		
SPAN (MAX)	HEIGHT OF VENEER ABOVE LINTEL	STEEL ANGLE SIZE
3'-0"	20 FT. MAX	L3"x3"x1/4"
	3 FT. MAX	L3"x3"x1/4"
6'-0"	12 FT. MAX	L4"x3"x1/4"
	20 FT. MAX	L5"x3 1/2"x3/8"
8'-0"	3 FT. MAX	L4"x4"x1/4" *
	12 FT. MAX	L5"x3 1/2"x3/8"
9'-6"	16 FT. MAX	L6"x3 1/2"x3/8"
	12 FT. MAX	L6"x3 1/2"x3/8"

ALL LINTELS:
 - SHALL SUPPORT 2 1/2" - 3 1/2" VENEER w/ 40 psf MAXIMUM HEIGHT.
 - 1/2" SHALL HAVE 4" MIN. BEARING
 - 1" SHALL HAVE 8" MIN. BEARING
 - 1 1/2" SHALL NOT BE FASTENED BACK TO HEADER
 - 1 1/2" SHALL BE FASTENED BACK TO WOOD HEADER IN WALL @ 48" o.c. w/ 1/2" DIA. x 3 1/2" LONG LAG SCREWS IN 2" LONG VERTICALLY SLOTTED HOLES
 - MAX. VENEER HT. APPLIES TO ANY PORTION OF BRICK OVER THE OPENING.
 - ALL LINTELS SHALL BE LONG LEG VERTICAL.
 - WHEN SUPPORTING VENEER & 9" WIDE THE EXTERIOR TOE OF THE HORIZONTAL LEG MAY BE CUT IN THE FIELD TO BE 3/4" WIDE OVER THE BEARING LENGTH ONLY. THIS IS TO ALLOW FOR HORIZONTAL JOINT FINISHING.
 - SEE STRUCTURAL PLANS FOR ANY LINTEL CONDITION NOT ENCOMPASSED BY THE ABOVE PARAMETERS.
 * FOR QUEEN VENEER USE L4"x3/4".

MK STD. - MAY 2016

GENERAL STRUCTURAL NOTES

FOUNDATION

- DESIGN IS BASED ON 2018 NCSCB-RESIDENTIAL CODE & 2018 IRC WITH SOUTH CAROLINA AMENDMENTS
- FOOTING DESIGN - 2,000 PSF NET ALLOWABLE SOIL BEARING PRESSURE IS ASSUMED. BUILDER/CONTRACTOR MUST VERIFY.
- FASTEN 2x4/6 SILL PLATES TO CONC FND WITH A MINIMUM OF 2 ANCHORS PER PLATE, 12" MAX. FROM PLATE ENDS - UTILIZING:
 - 1/2" DIA. ANCHOR BOLTS @ 6'-0" O.C., 7" MIN. EMBEDMENT
 - FA4 ANCHOR STRAPS @ 6'-0" O.C.
- FASTEN 2x10 SILL PLATES TO PRECAST BSMT WALLS WITH A MINIMUM OF 2 ANCHORS PER PLATE, 12" MAX. FROM PLATE ENDS - UTILIZING:
 - 1/2" DIA. BOLTS @ 2'-0" O.C.
- ALL LUMBER EXPOSED TO WEATHER OR IN CONTACT w/ PERIMETER FOUNDATION SHALL BE PRESERVATIVE TREATED SOUTHERN PINE #2.
- BUILDER TO VERIFY CORROSION-RESISTANCE COMPATIBILITY OF HARDWARE & FASTENERS IN CONTACT w/ PRESERVATIVE-TREATED WOOD. CONTACT LUMBER & HARDWARE SUPPLIERS TO COORD.
- FOUNDATION WALLS & FOOTINGS SHALL BE PLAIN CONCRETE, U.N.O.
- CONCRETE DESIGN BASED ON ACI 318. CONCRETE SHALL ATTAIN THE FOLLOWING MIN. COMPRESSIVE STRENGTHS IN 28 DAYS, U.N.O.:
 - f'c = 4000 psi: FOUNDATION WALLS
 - 3000 psi: FOOTINGS & INTERIOR SLABS ON GRADE
 - 3500 psi: GARAGE & EXTERIOR SLABS ON GRADE
 - fy = 60,000 psi
- BASEMENT FOUNDATION WALL DESIGN BASED ON:
 - 8' OR 9' HEIGHT (AS NOTED ON PLANS)
 - TALLER WALLS MUST BE ENGINEERED.
- BASEMENT WALL DESIGN IS BASED ON 30 OR 45 PCF BACKFILL SOIL TYPE CLASSIFICATIONS:
 - 30 PCF TYPE (GM, GC, SM, SM-SC, ML)
 - 45 PCF TYPE (GM, GC, SM, SM-SC, ML)
 - IMPORTANT - IF 60 PCF SOIL TYPE (SC, ML-CL, OR CL) IS UTILIZED FOR BACKFILL, CONTACT MULHERN & KULP FOR FURTHER EVALUATION OF FOUNDATION DESIGN.
- BASEMENT WALLS SHALL BE BRACED, PRIOR TO BACKFILLING, BY ADEQUATE TEMPORARY BRACING OR INSTALL 1st FLOOR DECK.
- ALL CONCRETE EXPOSED TO THE WEATHER SHALL NOT HAVE LESS THAN 5% OR MORE THAN 1% AIR ENTRAINMENT.
- ALL FOOTINGS SHALL BEAR BELOW FROST LINE (TYP.) OR 12" MIN IN REGIONS WHERE CODE FROST DEPTH IS NOT APPLICABLE. CONSULT SOILS REPORT OR BUILDING DEPT. FOR MINIMUM DEPTH BELOW GRADE.
- FOOTINGS AND SLABS ON GRADE SHALL BEAR ON VIRGIN SOIL OR 95% COMPACTED FILL.
- PROVIDE CONTROL JOINTS AT ALL INSIDE CORNERS OF SLAB EDGES, AND OTHER LOCATIONS WHERE SLAB CRACKS ARE LIKELY TO DEVELOP.
 - JOINTS SHALL BE LOCATED @ 10'-0" O.C. (RECOMMENDED) OR 15'-0" O.C. (MAXIMUM)
 - JOINT GRID PATTERN SHALL BE AS CLOSE TO SQUARES AS POSSIBLE (1:1 RATIO), WITH A MAXIMUM OF 1:1.5 RATIO
 - CONTROL JOINTS SHALL NOT BE INSTALLED IN STRUCTURAL SLABS
- TYPICAL REINFORCEMENT DETAILS: PROVIDE 3" MIN. CLEAR COVER WHERE CAST AGAINST EARTH, 1 1/2" MIN. CLEAR COVER AGAINST FORMS. LAP ALL REBAR 48 BAR DIAMETERS MIN. (24" FOR #4 BARS) & BEND BARS AND LAP AT CORNERS. PROVIDE 6" HOOK INTO SUPPORTING FOOTINGS WHEN FOOTINGS INTERSECT.
- DIMENSIONS BY OTHERS, BUILDER TO VERIFY.

MK STD. - MAY 2012

LEGEND

- R.T.** INDICATES ROOF TRUSSES @ 24" O.C. PER ROOF. MANUF. (TYP. U.N.O.)
- O.P.** INDICATES TRUSS OVERFRAMING @ 24" O.C. (TYP. U.N.O.)
- F.J.** INDICATES 14" DEEP FLOOR I-JOISTS @ 24" O.C. MAX. JOIST SERIES AND SPACING SHALL BE THE RESPONSIBILITY OF THE MANUFACTURER. NOTE: 14" FLOOR TRUSSES @ 24" O.C. MAX. IS AN ACCEPTABLE ALTERNATE FLOOR SYSTEM
- INDICATES LOCATIONS OF POTENTIAL TILE FLOOR. JOIST MANUFACTURER SHALL DESIGN FLOOR SYSTEM FOR ADDL. 10 PSF DEAD LOAD AT THESE LOCATIONS.
- INTERIOR BEARING WALL
- BEARING WALL ABOVE (B.W.A.)
- BEAM/HEADER
- METAL HANGER
- INDICATES POST ABOVE (P.A.) PROVIDE SOLID BLOCKING UNDER POST OR JAMB ABOVE.

MK STD. - MAR 2016

LATERAL/WALL BRACING & WALL SHEATHING SPECIFICATIONS

THIS MODEL HAS BEEN DESIGNED TO RESIST LATERAL FORCES RESULTING FROM:
120MPH WIND IN 2018 NCSCB:RC & 120MPH WIND IN 2018 IRC
 (120 MPH WIND SPEED IN ASCE 7 WIND MAP, PER IRC R301.2.1.1) EXP. B, RISK CAT. 2 & SEISMIC CAT. A/B.

THE DESIGN WAS COMPLETED PER 2015 & 2018 IBC (SECTION 1604) & ASCE 7, AS PERMITTED BY R301.1.3 OF THE 2018 NCSCB:RC & 2018 IRC. ACCORDINGLY, THIS MODEL, AS DOCUMENTED AND DETAILED HEREWITHIN, IS ADEQUATE TO RESIST THE CODE REQUIRED LATERAL FORCES.

DESIGN WIND UPLIFT LOADS HAVE BEEN CALCULATED UTILIZING ASCE 7 (ACCEPTED ENGINEERING PRACTICE) AS ALLOWED PER 2018 NCSCB:RC & 2018 IRC SECTION R802.11.1.1. THIS MODEL HAS BEEN DETAILED WHERE REQUIRED & ENGINEERED TO RESIST THE WIND UPLIFT LOAD PATH PER SECTIONS R602.3.54 R802.11.

EXT. WALL SHEATHING SPECIFICATION

- 1/16" OSB OR 15/32" PLYWOOD:
 FASTEN SHEATHING w/ 2 3/8"x0.113 NAILS @ 6" o.c. AT EDGES & @ 12" o.c. IN THE PANEL FIELD. (TYP. U.N.O.)
- ALL SHEATHING PANELS SHALL BE ORIENTED VERTICALLY (LONG DIRECTION PARALLEL TO STUDS) AND INSTALLED FULL HEIGHT OF SHEAR WALL - OR - 2x HORIZONTAL BLOCKING SHALL BE PROVIDED TO SUPPORT ALL UNSUPPORTED PANEL EDGES & EDGE FASTENING.
- ALL EXT. WALLS SHALL BE CONTINUOUSLY SHEATHED AND ARE CONSIDERED SHEAR WALLS.
- ALT. STAPLE CONNECTION SPEC: 1 3/4" 16 GA STAPLES (1/6" CROWN) @ 3" o.c. AT EDGES & @ 6" o.c. IN FIELD.

3" O.C. EDGE NAILING

- AT DESIGNATED AREAS - FASTEN PANEL EDGES OF WOOD STRUCTURAL WALL SHEATHING TO FRAMING w/ 2 3/8" x 0.113" NAILS @ 3" o.c. AND 12" o.c. IN THE PANEL FIELD. NO STAPLE ALTERNATIVE AVAILABLE AT THIS SPEC. ALL SHEATHING PANELS SHALL BE ORIENTED VERTICALLY (LONG DIRECTION PARALLEL TO STUD) AND INSTALLED FULL HEIGHT OF SHEAR WALL - OR - 2x HORIZONTAL BLOCKING SHALL BE PROVIDED TO SUPPORT UNSUPPORTED PANEL EDGES AND 3" o.c. EDGE FASTENING.

NOTES

- SEE CONNECTION SPECIFICATIONS CHART FOR STANDARD SHEAR TRANSFER DETAILING. IF ADDITIONAL CAPACITY IS REQUIRED BY DESIGN, IT WILL BE SPECIFICALLY NOTED ON PLAN.
- DESIGN ASSUMES 16" O.C. MAX. STUD SPACING, U.N.O.
- ALL STRUCTURAL PANELS ARE TO BE DIRECTLY APPLIED TO STUD FRAMING.
- PRE-MANUFACTURED PANELIZED WALLS: FASTEN TOGETHER END STUDS OF WALL PANELS SHEATHED w/ OSB OR PLYWOOD w/ 3" x 0.120" NAILS @ 4" o.c. (THRU ONE SIDE ONLY)
- INDICATES EXTENT OF INT. OSB SHEARWALL, AND/OR 3" o.c. EDGE NAILING
- INDICATES HOLD/DOWN

MK STD. - MAR 2016

NON-BEARING HEADER SCHEDULE

SPAN	2x4 NON-BEARING PARTITION WALL	2x6 NON-BEARING PARTITION WALL
UP TO 3'-0"	(1)2x4 FLAT	(1)2x6 FLAT
UP TO 6'-0"	(2)2x4	(3)2x4
UP TO 8'-0"	(2)2x6	(3)2x6

NOTES:

- ALL NON-BEARING INTERIOR STUD WALLS SHALL BE CONSTRUCTED WITH 2x STUD GRADE MEMBERS SPACED @ 24" O.C. (MAX.)

FLOOR FRAMING

- I-JOISTS SHALL BE DESIGNED BY MANUF. TO MEET OR EXCEED L/480 LIVE LOAD DEFLECTION CRITERIA. (EXCLUDES STONE/MARBLE OR NET BED CONSTRUCTED FLOORS - CONTACT MK FOR EXCLUDED FLOOR DESIGNS)
- PER THE GUIDELINES OF THE TILE COUNCIL OF NORTH AMERICA (TCNA HANDBOOK), IT SHALL BE THE FLOOR FINISH INSTALLER'S RESPONSIBILITY TO VERIFY THAT THE FINISHES TO BE INSTALLED MATCH THE DESIGN CRITERIA NOTED ABOVE (UNDER "DESIGN LOADS").
- FLOOR SYSTEMS & SHEATHING HAVE BEEN DESIGNED TO SUPPORT ADDITIONAL DEAD LOAD FROM CERAMIC TILE (EXCLUDING MARBLE OR STONE). HOWEVER, IT SHALL BE THE FLOOR FINISH INSTALLER'S RESPONSIBILITY TO PROVIDE PROPER UNDERLAYMENT, UNCOUPLING MEMBRANE AND MORTAR/GROUT PER THE ASSEMBLY DESIGNATIONS IN THE TCNA HANDBOOK (TILE COUNCIL OF NORTH AMERICA).
- AT I-JOIST FLOORS, PROVIDE 1" MIN. OSB RIM BOARD.
- METAL HANGERS SHALL BE SPECIFIED BY MANUFACTURER, U.N.O.
- I-JOIST SHOP DWGS. SHALL BE SUBMITTED TO ARCH. & ENG. FOR REVIEW AND APPROVAL PRIOR TO FABRICATION OR DELIVERY.
- FLOOR SHEATHING SHALL BE 23/32" A.P.A. RATED 'STURD-I-FLOOR' 24" o.c. EXPOSURE 1 (OR APPROVED EQUAL) WITH TONGUE AND GROOVE EDGES. FASTEN TO FRAMING MEMBERS w/ GLUE AND:
 - 2 1/2" x 0.131" NAILS @ 6" o.c. @ PANEL EDGES & @ 12" o.c. FIELD.
 - 2 3/8" x 0.120" NAILS @ 4" o.c. @ PANEL EDGES & @ 8" o.c. FIELD.
 - 2 3/8" x 0.113" NAILS @ 3" o.c. @ PANEL EDGES & @ 6" o.c. IN FIELD.

ROOF FRAMING

- ROOF SHEATHING SHALL BE 7/16" A.P.A. RATED SHEATHING 24/16 EXPOSURE 1 (OR APPROVED EQUAL). FASTEN TO FRAMING MEMBERS:
 - w/ 2 1/2" x 0.131" NAILS @ 6" o.c. @ PANEL EDGES & @ 12" o.c. FIELD.
 - w/ 2 3/8" x 0.120" NAILS @ 4" o.c. @ PANEL EDGES & @ 8" o.c. FIELD.
 - w/ 2 3/8" x 0.113" NAILS @ 3" o.c. @ PANEL EDGES & @ 6" o.c. FIELD.
- WITHIN 48" OF ALL ROOF EDGES, RIDGES, & HIPS FASTEN ROOF SHEATHING FIELDS PER EDGE NAILING SPEC.
- FASTEN EACH ROOF TRUSS TO TOP PLATE w/ USP RTIA CLIP (OR APPROVED EQUAL) @ ALL BEARING POINTS. PROVIDE (2) RTIA CLIPS AT 2-PLY GIRDER TRUSSES, (3) RTIA CLIPS AT 3-PLY GIRDER TRUSSES & ROOF BEAMS - AT ALL BEARING POINTS.
- METAL HANGERS SHALL BE SPECIFIED BY THE MANUFACTURER, U.N.O.
- ROOF TRUSS SHOP DWGS. SHALL BE SUBMITTED TO ARCH & ENG. FOR REVIEW AND APPROVAL PRIOR TO FABRICATION OR DELIVERY.
- ERECT AND INSTALL ROOF TRUSSES PER WTA & TPI'S BC51 I "GUIDE TO GOOD PRACTICE FOR HANDLING, INSTALLING & BRACING OF METAL PLATE CONNECTED WOOD TRUSSES."
- SUPPORT SHORT SPAN ROOF TRUSSES w/ 2x4 LEDGER FASTENED TO FRAMING w/ (2) 3" x 0.120" NAILS @ 16" o.c. (UP TO 7' SPAN).

MK STD. - MAR 2016

MEANS & METHODS NOTES

THE STRUCTURE IS DESIGNED TO BE SELF SUPPORTING AND STABLE AFTER THE BUILDING IS FINISHED AND ALL PLAN, DETAIL, AND NOTE SPECIFICATIONS HAVE BEEN COMPLETED. IT IS THE CONTRACTOR'S SOLE RESPONSIBILITY TO DETERMINE THE ERECTION PROCEDURES AND SEQUENCE TO INSURE THE SAFETY OF THE BUILDING AND ITS COMPONENTS DURING CONSTRUCTION. THIS INCLUDES, BUT IS NOT LIMITED TO, THE ADDITION OF NECESSARY SHORING, SHEETING, TEMPORARY BRACING, GUY'S, AND TIE-DOWNS. CONTRACTOR SHALL BE RESPONSIBLE FOR ALL SHORING AND BRACING REQUIRED TO STABILIZE AND PROTECT EXISTING AND ADJACENT STRUCTURES AND SYSTEMS DURING COURSE OF DEMOLITION AND CONSTRUCTION OF THE PROJECT.

STRUCTURAL DESIGN AND SPECIFICATIONS ASSUME THAT ALL SUPPORTING AND NON-SUPPORTING ELEMENTS IN CONTACT WITH FLOOR FRAMING ARE LEVEL, INCLUDING, BUT NOT LIMITED TO; FOUNDATIONS, SLABS ON GRADE, BEAMS, WALLS, AND NON-BEARING ELEMENTS. IT IS THE CONTRACTOR'S RESPONSIBILITY TO VERIFY LEVELNESS AND MAKE ADJUSTMENTS AS NECESSARY, INCLUDING CONSIDERATION OF THOSE AREAS THAT MAY BE WITHIN CONTRACTUAL, INDUSTRY, OR WARRANTY TOLERANCES.

GENERAL STRUCTURAL NOTES

- DESIGN IS BASED ON 2018 NCSCB-RESIDENTIAL CODE & 2018 IRC WITH SOUTH CAROLINA AMENDMENTS
- WOOD FRAME ENGINEERING IS BASED ON NDS, "NATIONAL DESIGN SPECIFICATION FOR WOOD CONSTRUCTION" - LATEST EDITION.
- DESIGN LOADS:
 - ROOF: LIVE = 20 PSF, DEAD = 7 PSF T.C., 10 PSF B.C. LOAD DURATION FACTOR = 1.25
 - FLOOR: LIVE = 40 PSF (30 PSF @ SLEEPING AREAS), DEAD = 10 PSF (1-JOISTS)
 - ADDL. 10 PSF @ CERAMIC TILE IN BATHS & LAUND.
 - SOIL: 2,000 PSF ASSUMED ALLOWABLE BEARING PRESSURE (TO BE VERIFIED BY BUILDER)

GENERAL FRAMING

- ALL TYP. NAIL FASTENER REQUIREMENTS ARE NOTED IN STANDARD CONNECTIONS TABLE (IRC TABLE R602.3(1)) OR ON PLANS. ALL NAILS SPECIFIED ARE MIN DIAMETER AND LENGTH REQUIRED FOR CONNECTION. ALL HANGER NAILS SHALL BE INSTALLED PER MANUFACTURER'S REQUIREMENTS FOR MAX CHARTED CAPACITY. NOTE: HANGERS USE COMMON NAIL DIAMETERS NOT TYPICAL FRAMING GUN NAILS.
- EXT. & INT. BEARING WALLS SHALL BE 2x4 OR 2x6 (AS SHOWN ON PLANS) @ 16" o.c. SPP/SP "STUD" GRADE LUMBER, OR BETTER, U.N.O.
 - WALLS OVER 12' TALL SHALL BE PER PLAN.
- ALL INTERIOR BEARING WALLS ARE ASSUMED TO BE SHEATHED w/ GYP WALL BOARD (ONE SIDE MIN.) OR PROVIDE MID HT. BLOCKING.
- ALL HEADERS, BEAMS & OTHER STRUCTURAL MEMBERS SHALL BE SPRUCE-PINE-FIR #2 (SPF) OR SOUTHERN PINE #2 (SP) LUMBER, OR BETTER. SUPPORT ALL HEADERS/ BEAMS w/ (1)2x JACK STUD @ (1)2x KING STUD, MINIMUM. - THE NUMBER OF STUDS SPECIFIED AT A SUPPORT INDICATES THE NUMBER OF JACK STUDS REQUIRED, U.N.O.
- ALL NON-BEARING INTERIOR STUD WALLS SHALL BE CONSTRUCTED WITH 2x STUD GRADE MEMBERS SPACED @ 24" O.C. (MAX. U.N.O.)
 - HEADERS IN NON-LOAD BEARING WALLS SHALL BE: (1)2x4/6 FLAT @ OPENINGS UP TO 4', (2)2x4/6 FLAT UP TO 8'.
- ALL FRAMING LUMBER SHALL BE DRIED TO 15% MC (KD-15).
- ENGINEERED LUMBER BEAMS TO MEET OR EXCEED THE FOLLOWING:
 - "LVL" - Fb=2600 psi; Fv=285 psi; E=2.0x10⁶ psi
- ENGINEERED LUMBER POSTS TO MEET OR EXCEED THE FOLLOWING:
 - "LVL" - Fb=2400 psi; FcII=2500 psi; E=1.8x10⁶ psi
- FOR 2 & 3 PLY BEAMS OF EQUAL 1 1/2" MAX. WIDTH, FASTEN PLIES TOGETHER WITH 3 ROWS OF 3"x0.120" NAILS @ 8" o.c. OR 2 ROWS USP MS65 SCREWS (OR 3 1/2" TRUSSLOK SCREWS) @ 16" o.c. USE A MINIMUM OF 4 ROWS FOR BEAM DEPTHS OF 14" OR GREATER. APPLY FASTENING AT BOTH FACES FOR 3-PLY CONDITION. LOCATE TOP & BOTTOM NAILS/SCREWS 2" FROM EDGE. SOLID 3 1/2" OR 5 1/2" BEAMS ARE ACCEPTABLE. USE 2 ROWS OF NAILS FOR 2x6 & 2x8 MEMBERS.
- FOR 4 PLY BEAMS OF EQUAL 1 1/2" MAX. WIDTH, FASTEN PLIES TOGETHER WITH 3 ROWS OF USP MS6 SCREWS (OR 6 3/4" TRUSSLOK SCREWS) @ 16" o.c. USE A MINIMUM OF 4 ROWS FOR BEAM DEPTHS OF 14" OR GREATER. APPLY FASTENING AT BOTH FACES (ONE SIDE ONLY FOR TRUSSLOK SCREWS). LOCATE TOP AND BOTTOM SCREWS 2" FROM EDGE. A SOLID 7" BEAM IS ACCEPTABLE.
- PROVIDE SOLID BLOCKING IN FLOOR SYSTEM UNDER ALL POSTS CONTINUOUS TO FND/BEARING. BLOCKING TO MATCH POST ABOVE.
- ALL EXTERIOR 4x4 WOOD POSTS SHALL HAVE USP BC522-4 CAP & PA44E BASE, U.N.O.
- CORROSION NOTES:
 - BUILDER RESPONSIBLE TO DETERMINE CORROSION-RESISTANCE REQUIREMENTS AND COMPATIBILITY OF HARDWARE, FASTENERS AND CONNECTORS FOR ENVIRONMENTAL EXPOSURE AND IN CONTACT w/ PRESERVATIVE-TREATED WOOD OF ACTUAL FINAL CONDITIONS AND SOURCED MATERIALS. CONTACT LUMBER & HARDWARE SUPPLIERS TO COORD.
 - ALL FASTENERS AND CONNECTORS EXPOSED TO SALT WATER (WITHIN 300' OF SALT WATER SHORELINE, INCLUDING VENTED SPACES) SHALL BE STAINLESS STEEL.

MK STD. - MAR 2016



Mulhern+Kulp project number:
256-22018

project mgr: **SMK**
 drawn by: **RAP**
 issue date: **01.05.2023**

REVISIONS:
 date: _____ initial: _____

SMITH DOUGLAS HOMES

GENERAL STRUCTURAL NOTES

GRAYSON MODEL

120 MPH WIND ZONE
 NORTH CAROLINA

BRIARWOOD Lot 37

sheet: **SO.0**

Mulhern+Kulp project number:
 256-22018

project mgr: SMK
 drawn by: RAP
 issue date: 01.05.2023

REVISIONS:
 date: initial:

SMITH DOUGLAS
 HOMES

MONO-SLAB FOUNDATION
 GRAYSON MODEL
 120 MPH WIND ZONE
 NORTH CAROLINA

sheet:
S1.0M

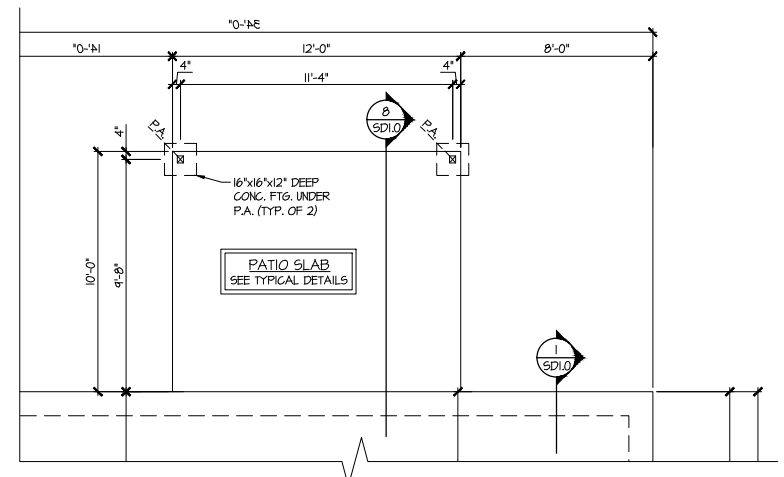

2 PARTIAL MONO-SLAB FOUNDATION PLAN
 SCALE: 1/4"=1'-0" ON 22x34
 1/8"=1'-0" ON 11x17
 OPT. COVERED PATIO
 ALL ELEVS. SIM.
 SEE BASE ELEV. FOR ADD'L INFO.

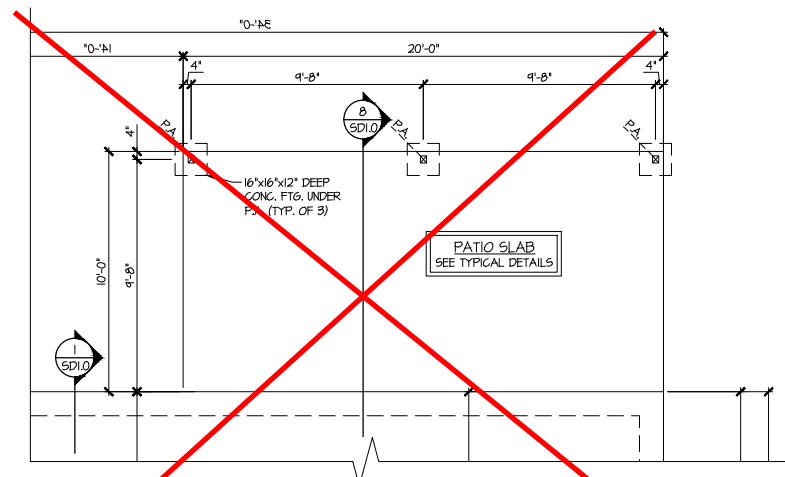

3 PARTIAL MONO-SLAB FOUNDATION PLAN
 SCALE: 1/4"=1'-0" ON 22x34
 1/8"=1'-0" ON 11x17
 OPT. LARGE COVERED PATIO
 ALL ELEVS. SIM.
 SEE BASE ELEV. FOR ADD'L INFO.

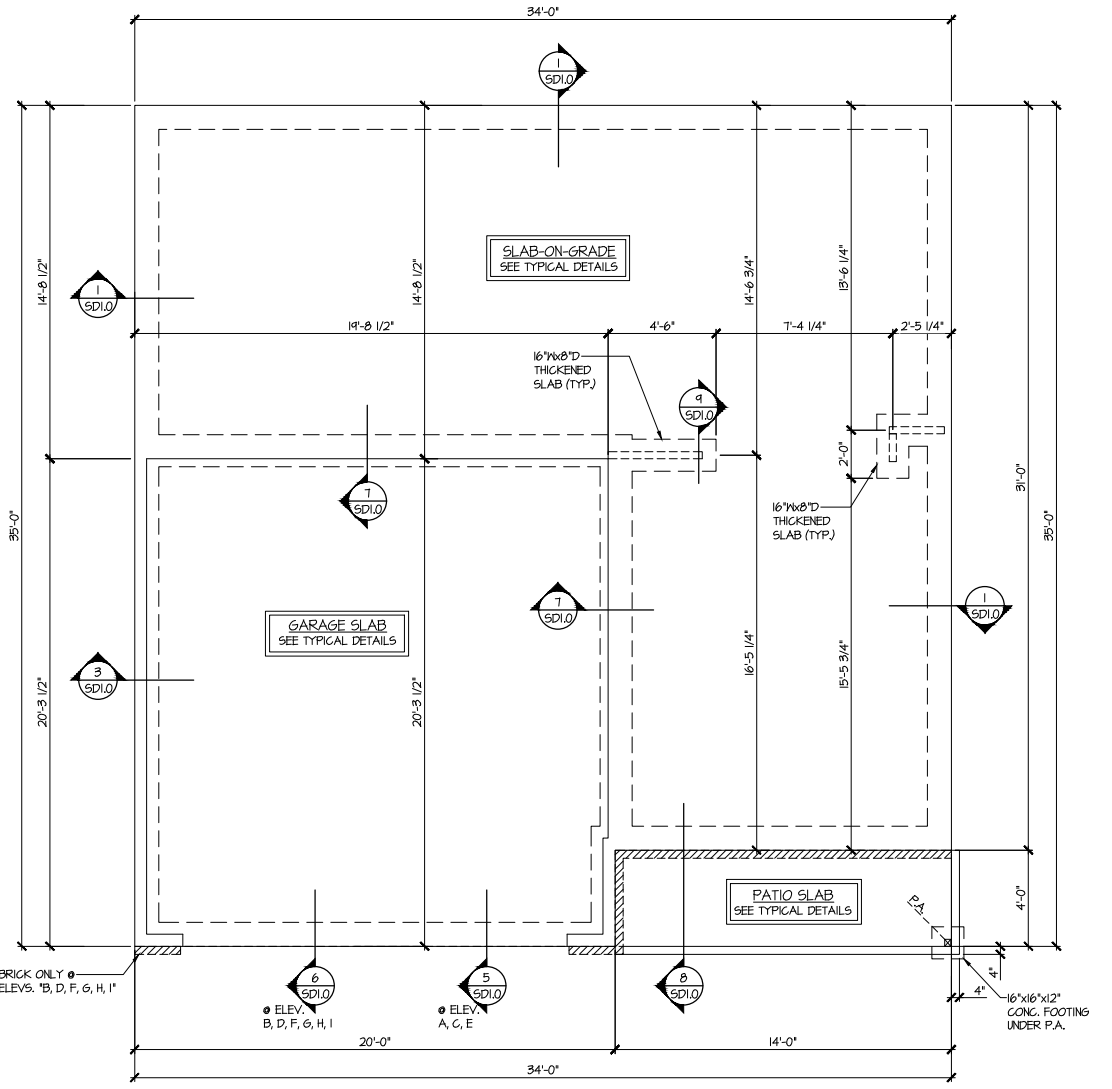

1 MONO-SLAB FOUNDATION PLAN
 SCALE: 1/4"=1'-0" ON 22x34
 1/8"=1'-0" ON 11x17
 ALL ELEVS. SIM.

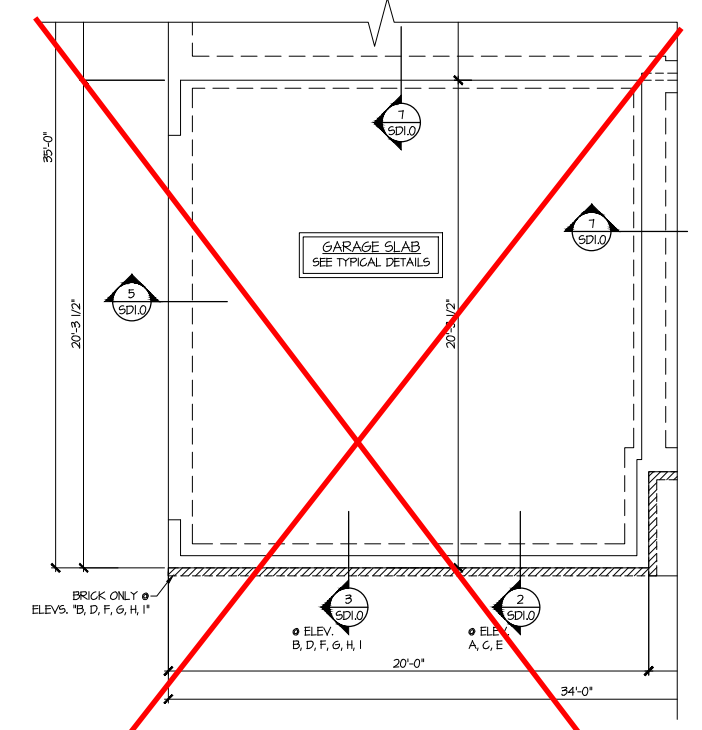

4 PARTIAL MONO-SLAB FOUNDATION PLAN
 SCALE: 1/4"=1'-0" ON 22x34
 1/8"=1'-0" ON 11x17
 OPT. SIDE ENTRY GARAGE
 ALL ELEVS. SIM.
 SEE BASE ELEV. FOR ADD'L INFO.

**BRIARWOOD
 Lot 37**

REFER TO S.O. FOR TYPICAL
 STRUCTURAL NOTES & SCHEDULES

LEGEND

- R.T. INDICATES ROOF TRUSSES @ 24" O.C. PER ROOF. MANUF. (TYP. UNO.)
- O.F. INDICATES TRUSS OVERFRAMING @ 24" O.C. (TYP. UNO.)
- F.J. INDICATES 14" DEEP FLOOR I-JOISTS @ 24" O.C. MAX. JOIST SERIES AND SPACING SHALL BE THE RESPONSIBILITY OF THE MANUFACTURER. NOTE: 14" FLOOR TRUSSES @ 24" O.C. MAX. IS AN ACCEPTABLE ALTERNATE FLOOR SYSTEM.
- INDICATES LOCATIONS OF POTENTIAL TILE FLOOR. JOIST MANUFACTURER SHALL DESIGN FLOOR SYSTEM FOR ADD'L 10 PSF DEAD LOAD AT THESE LOCATIONS.
- INTERIOR BEARING WALL
- BEARING WALL ABOVE (B.W.A.)
- BEAM/HEADER
- METAL HANGER
- INDICATES POST ABOVE (P.A.) PROVIDE SOLID BLOCKING UNDER POST OR JAMB ABOVE.

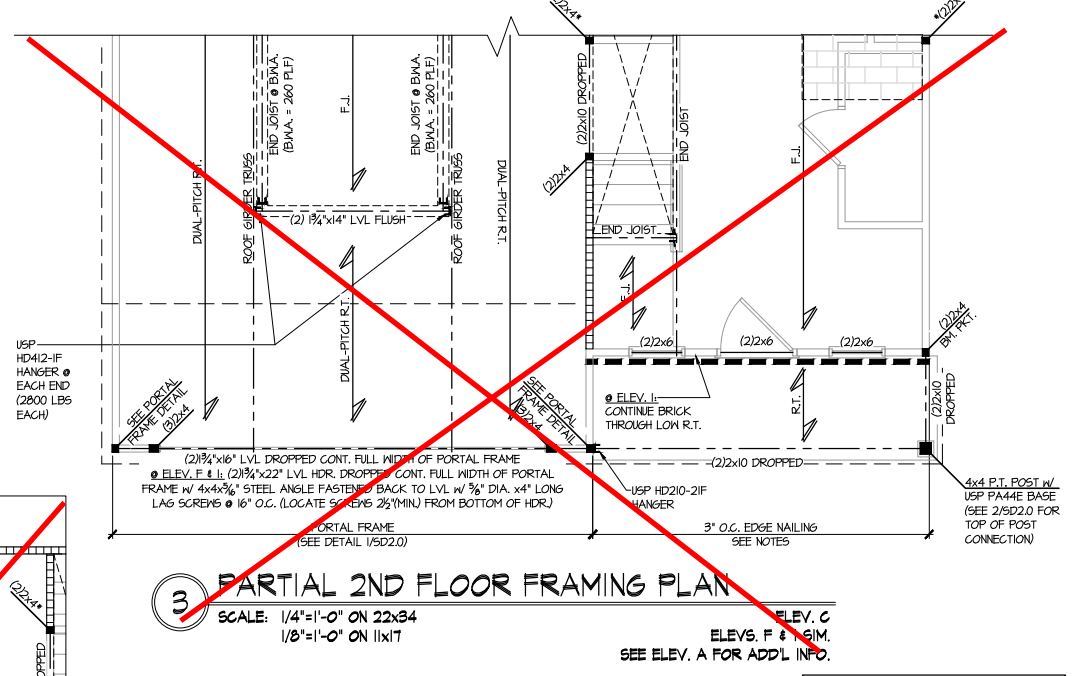
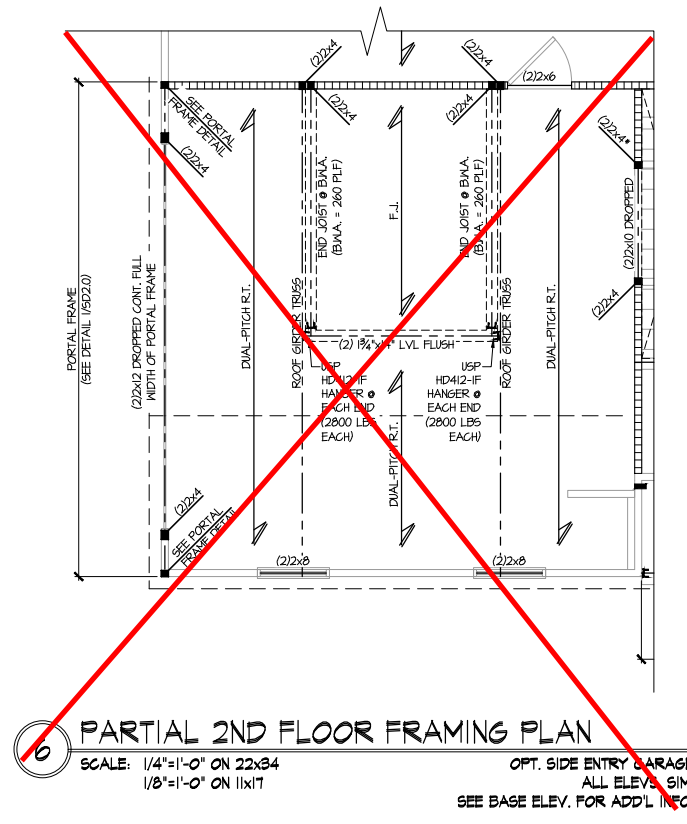
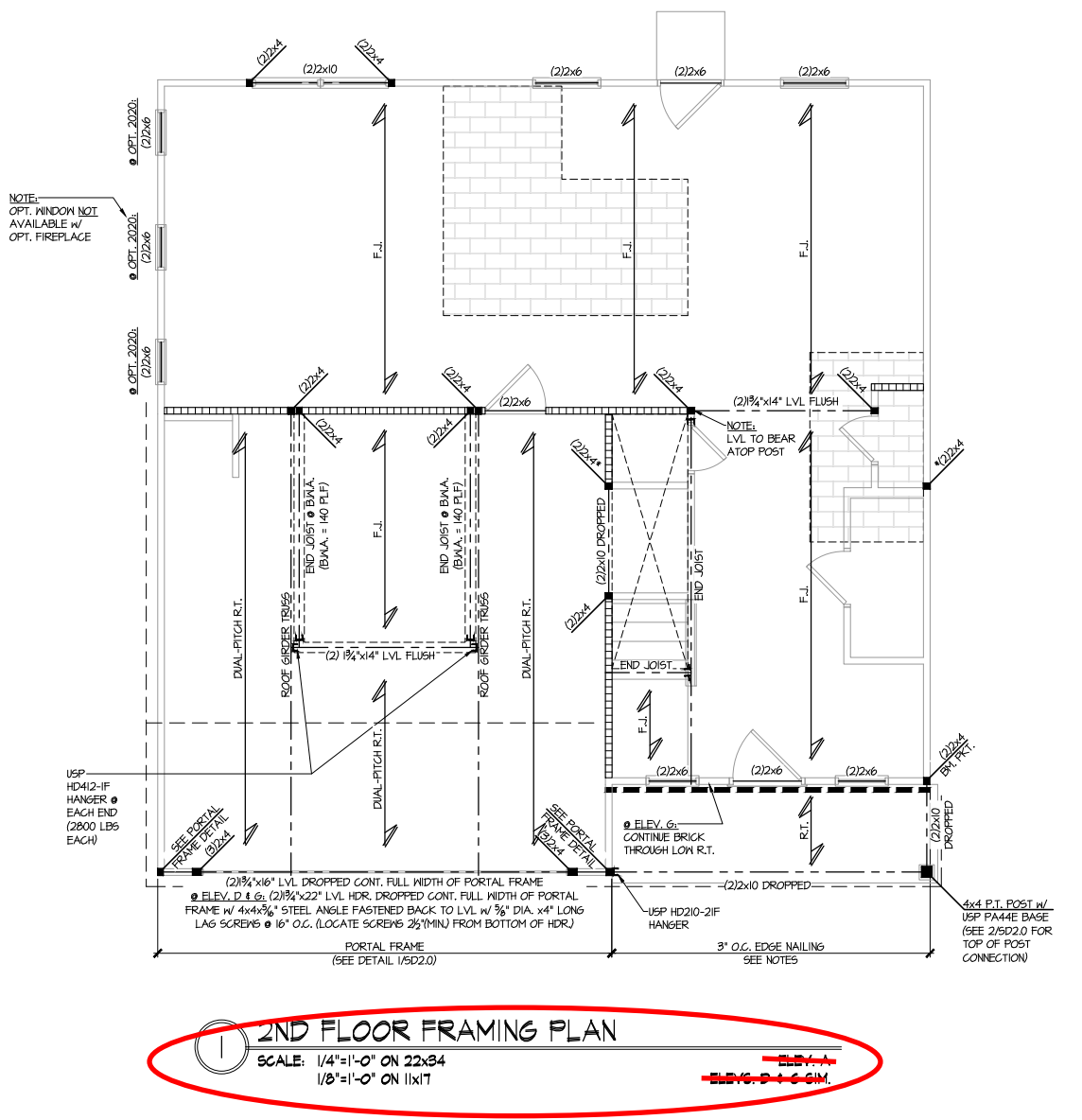
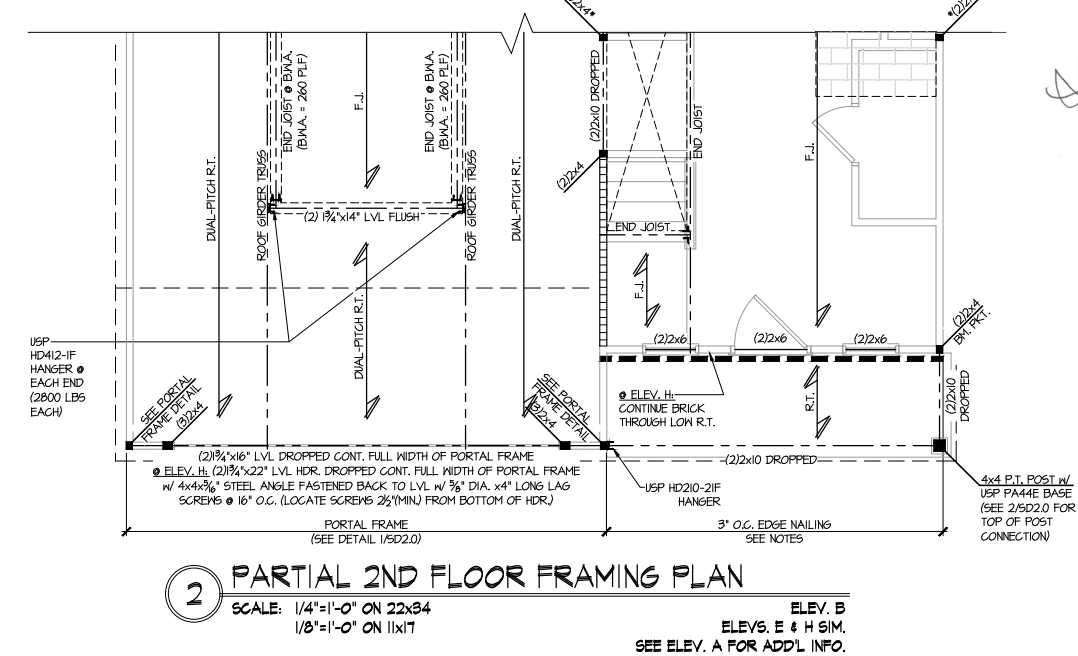
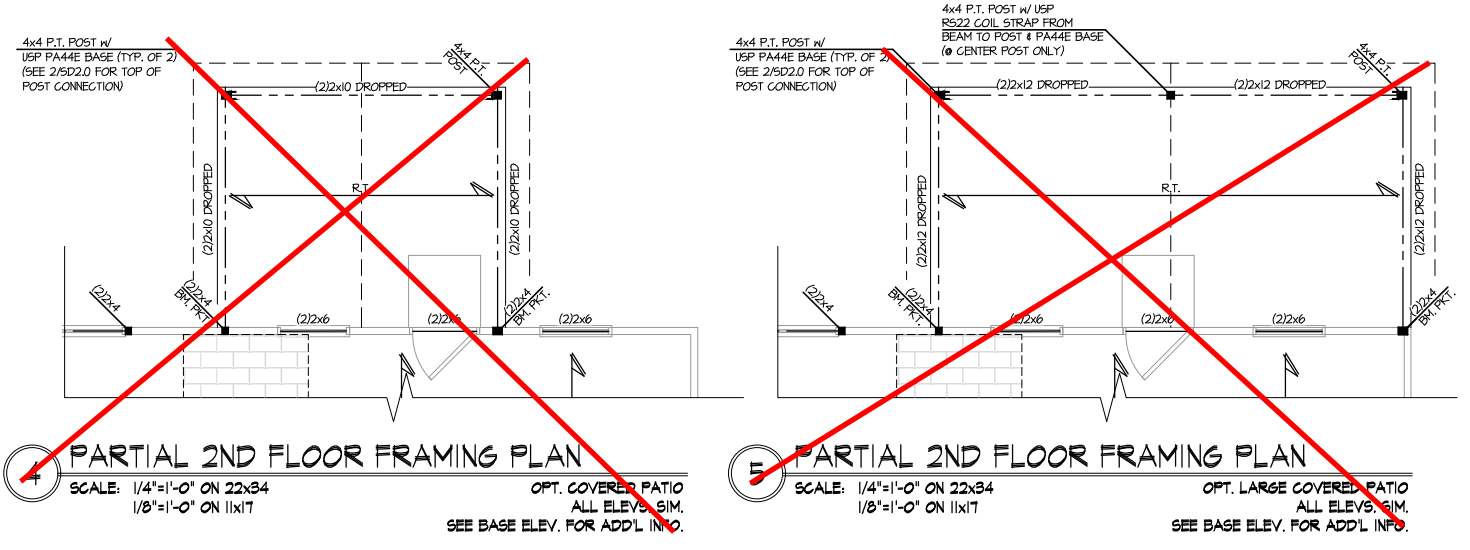

LEGEND

- R.T. INDICATES ROOF TRUSSES @ 24" O.C. PER ROOF. MANUF. (TYP. UNO.)
- O.F. INDICATES TRUSS OVERFRAMING @ 24" O.C. (TYP. UNO.)
- F.J. INDICATES 14" DEEP FLOOR I-JOISTS @ 24" O.C. MAX. JOIST SERIES AND SPACING SHALL BE THE RESPONSIBILITY OF THE MANUFACTURER. NOTE: 14" FLOOR TRUSSES @ 24" O.C. MAX. IS AN ACCEPTABLE ALTERNATE FLOOR SYSTEM
- [Symbol] INDICATES LOCATIONS OF POTENTIAL TILE FLOOR. JOIST MANUFACTURER SHALL DESIGN FLOOR SYSTEM FOR ADDL. 10 PSF DEAD LOAD AT THESE LOCATIONS.
- [Symbol] INTERIOR BEARING WALL
- [Symbol] BEARING WALL ABOVE (B.W.A.)
- [Symbol] BEAM/HEADER
- [Symbol] METAL HANGER
- * INDICATES POST ABOVE (P.A.) PROVIDE SOLID BLOCKING UNDER POST OR JAMB ABOVE.

THIS LEVEL HAS BEEN DESIGNED FOR 9'-1" PLATE HEIGHT

REFER TO S.O. FOR TYPICAL STRUCTURAL NOTES & SCHEDULES

BRIARWOOD
 Lot 37

Mulhern+Kulp project number:
 256-22018

project mgr: SMK
 drawn by: RAP
 issue date: 01.05.2023

REVISIONS:
 date: initial:









SMITH DOUGLAS
 HOMES

2ND FLOOR FRAMING PLAN
 GRAYSON MODEL
 120 MPH WIND ZONE
 NORTH CAROLINA

sheet:
S2.0M

**BRIARWOOD
 Lot 37**

THIS LEVEL HAS BEEN DESIGNED FOR 9'-1" PLATE HEIGHT
 REFER TO S.O.0 FOR TYPICAL STRUCTURAL NOTES & SCHEDULES

LEGEND	
	INDICATES ROOF TRUSSES @ 24" O.C. PER ROOF. MANIF. (TYP. U.N.O.)
	INDICATES TRUSS OVERFRAMING @ 24" O.C. (TYP. U.N.O.)
	INDICATES 14" DEEP FLOOR I-JOISTS @ 24" O.C. MAX. JOIST SERIES AND SPACING SHALL BE THE RESPONSIBILITY OF THE MANUFACTURER. NOTE: 14" FLOOR TRUSSES @ 24" O.C. MAX. IS AN ACCEPTABLE ALTERNATE FLOOR SYSTEM
	INDICATES LOCATIONS OF POTENTIAL TILE FLOOR. JOIST MANUFACTURER SHALL DESIGN FLOOR SYSTEM FOR ADDL. 10 PSF DEAD LOAD AT THESE LOCATIONS.
	INTERIOR BEARING WALL
	BEARING WALL ABOVE (B.W.A.)
	BEAM/HEADER
	METAL HANGER
	INDICATES POST ABOVE (P.A.) PROVIDE SOLID BLOCKING UNDER POST OR JAMB ABOVE.

ROOF FRAMING PLAN
 GRAYSON MODEL
 120 MPH WIND ZONE
 NORTH CAROLINA

sheet:
S3.0M

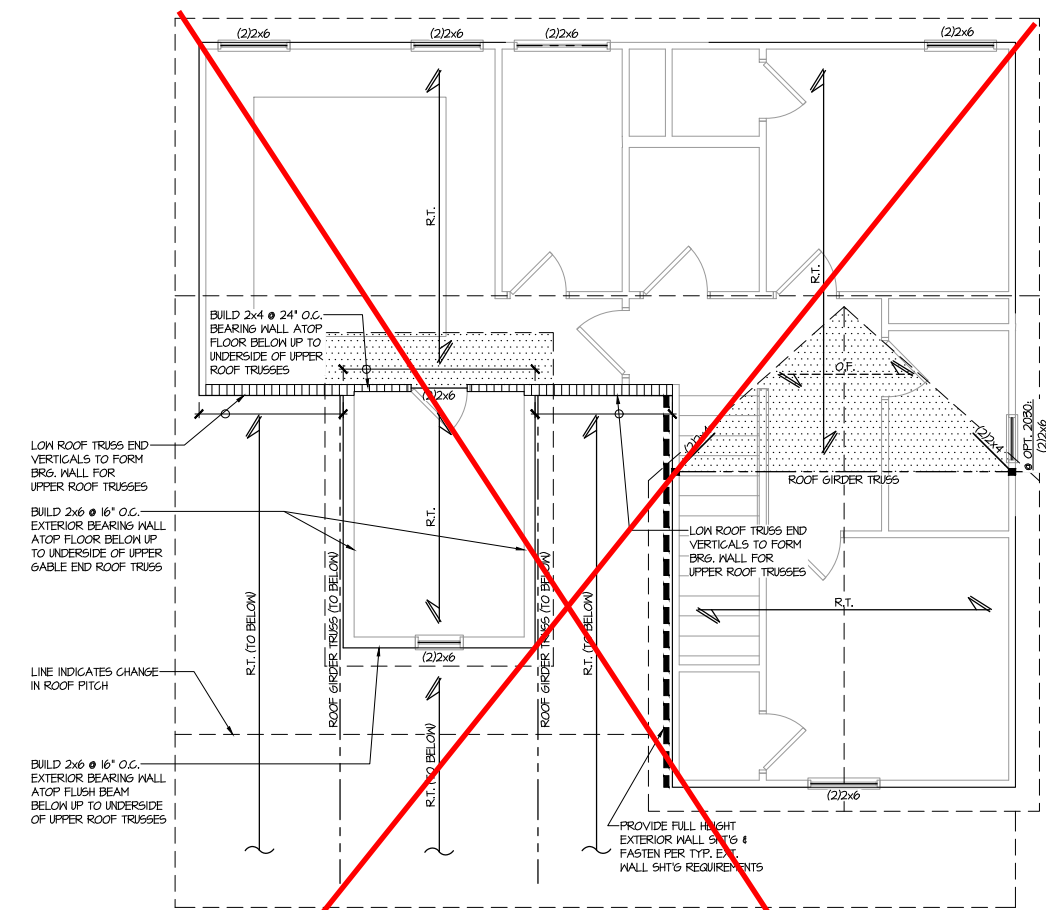

1 ROOF FRAMING PLAN
 SCALE: 1/4"=1'-0" ON 22x34
 1/8"=1'-0" ON 11x17
 ELEV. A
 ELEVS. D & G SIM.

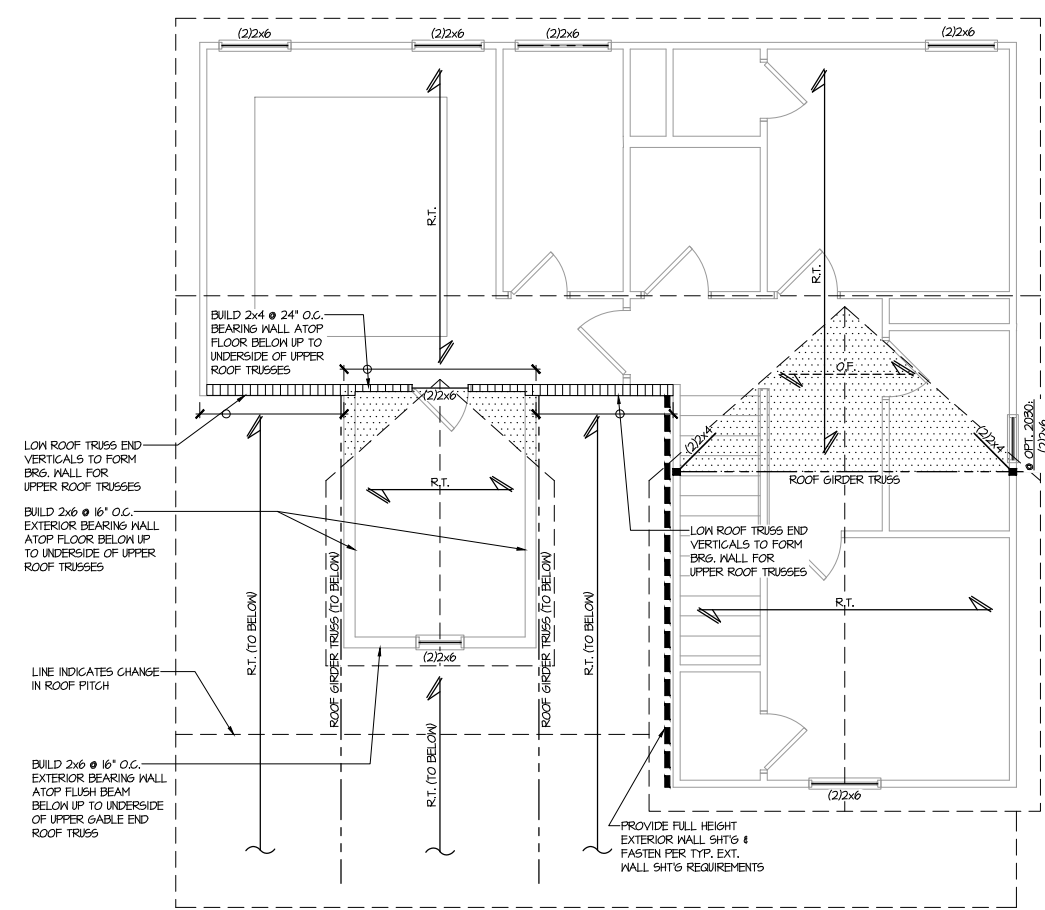

2 ROOF FRAMING PLAN
 SCALE: 1/4"=1'-0" ON 22x34
 1/8"=1'-0" ON 11x17
 ELEV. B
 ELEVS. E & H SIM.

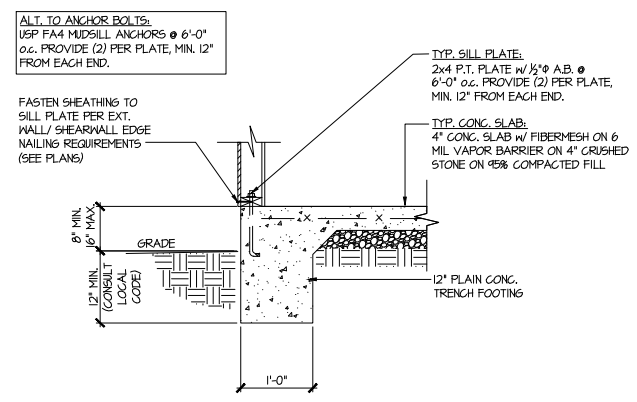

1 TYPICAL SLAB ON GRADE PERIMETER FOOTING

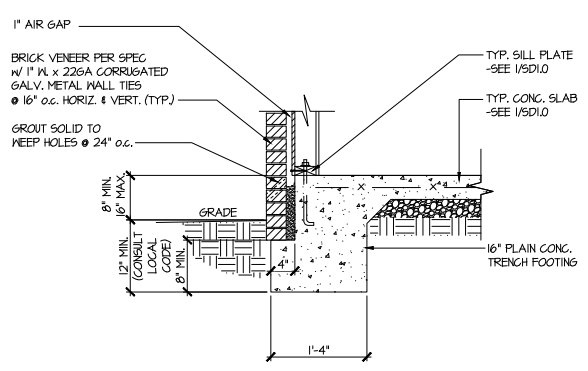

2 TYPICAL SLAB ON GRADE PERIMETER FOOTING w/ BRICK VENEER

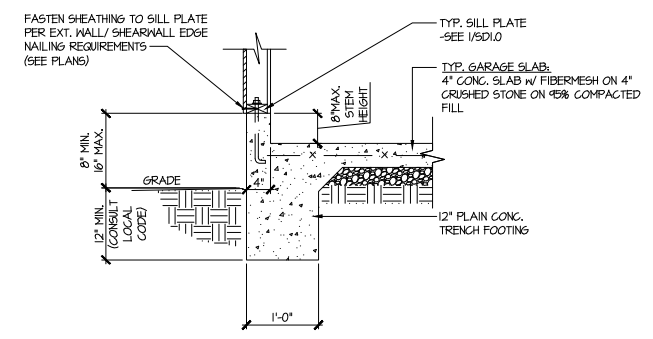

3 TYPICAL SLAB ON GRADE GARAGE PERIMETER FOOTING

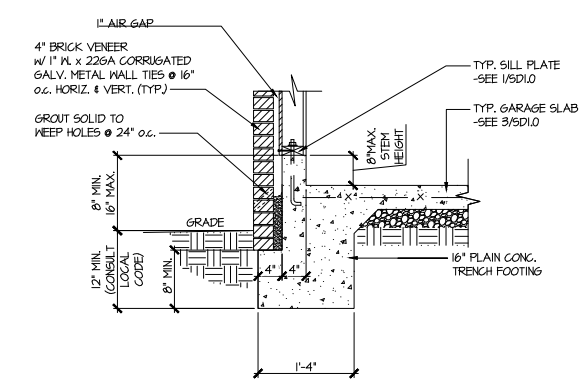

4 TYPICAL SLAB ON GRADE GARAGE PERIMETER FOOTING w/ BRICK VENEER

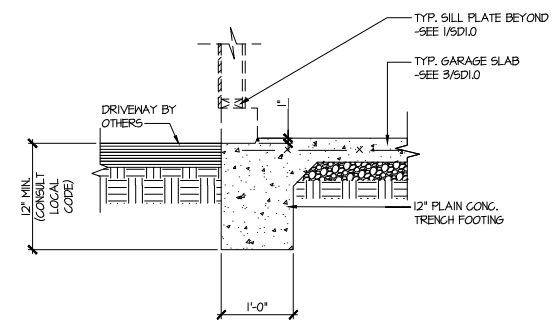

5 TYPICAL SLAB ON GRADE GARAGE ENTRY @ PERIMETER FOOTING

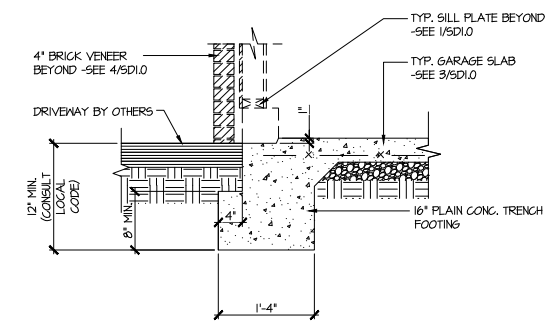

6 TYPICAL SLAB ON GRADE GARAGE ENTRY @ PERIMETER FOOTING w/ BRICK VENEER

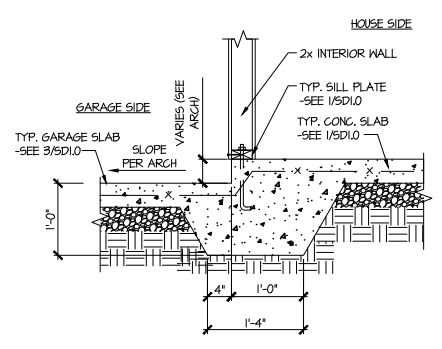

7 TYPICAL MONOLITHIC INTERIOR GARAGE FOOTING

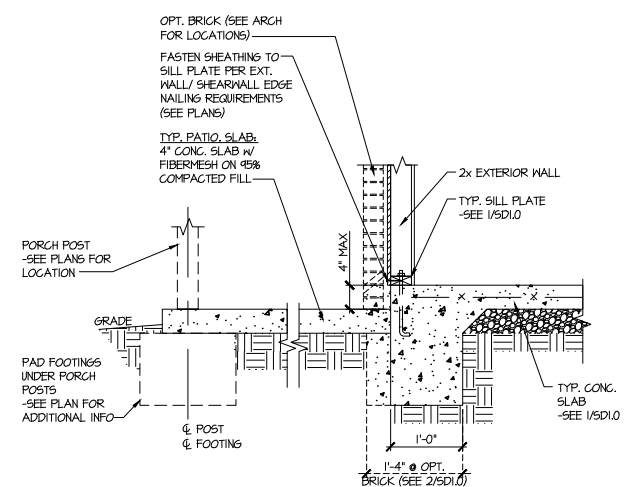

8 TYPICAL SLAB ON GRADE PERIMETER FOOTING @ PORCH/PATIO

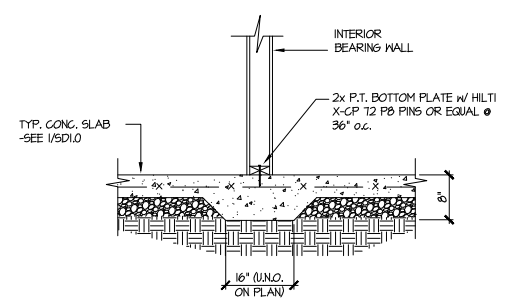

9 TYPICAL THICKENED SLAB @ INTERIOR BEARING WALL

MULHERN+KULP
 RESIDENTIAL STRUCTURAL ENGINEERING
 3025 Shuman Blvd., Suite 105 - Alpharetta, GA 30022
 770-777-8974 - mulhern+kulp.com
 NC License # C-3825

Mulhern+Kulp project number:
 256-22018

project mgr: SMK
 drawn by: RAP
 issue date: 01.05.2023

REVISIONS:
 date: initial:

SMITH DOUGLAS
 HOMES

FOUNDATION DETAILS
 GRAYSON MODEL
 120 MPH WIND ZONE
 NORTH CAROLINA

BRIARWOOD
 Lot 37

sheet:
SD1.0

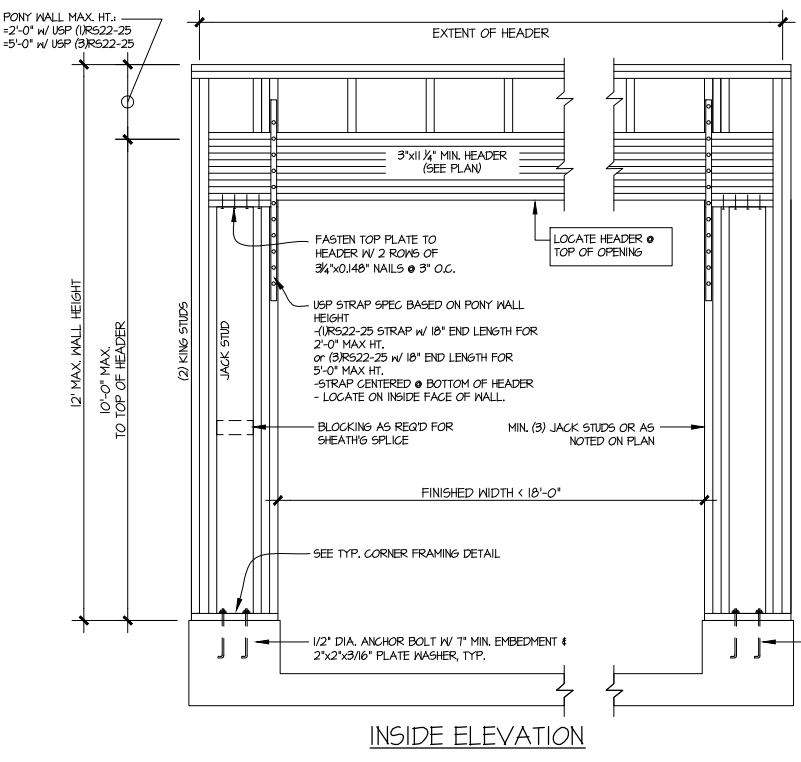
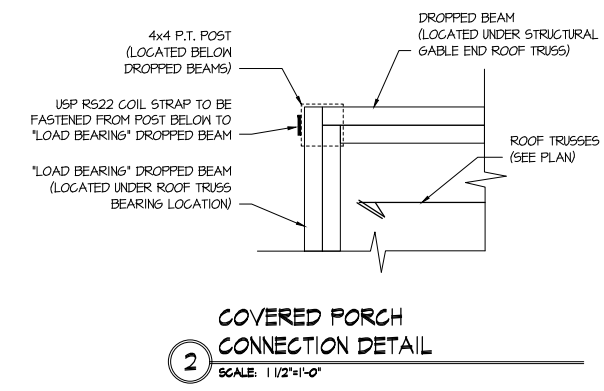
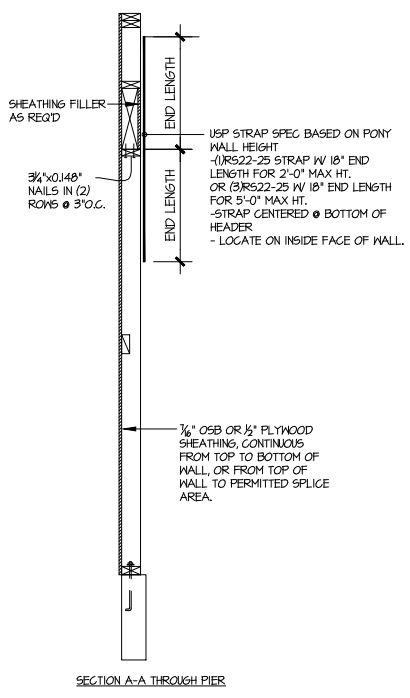
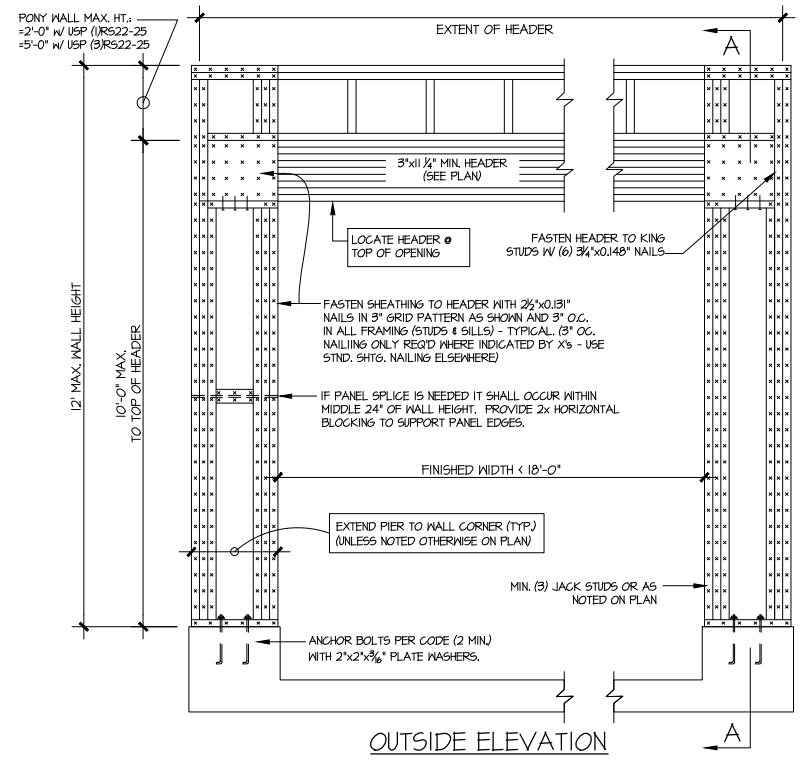

NOTE: ALL SHEATHABLE AREAS OF EXTERIOR WALL SHALL BE FULLY SHEATHED WITH 1/2" PLYWOOD OR 3/8" OSB

WALL FRAMING SPECIFICATION:
 2x4 WALL: USE SPF #2 GRADE STUDS (OR BETTER)
 2x6 WALL: USE SPF #1UD GRADE STUDS (OR BETTER)

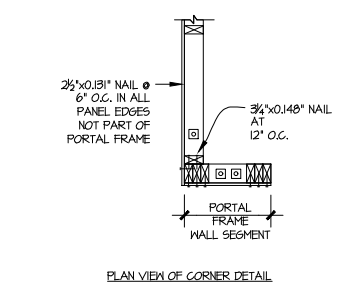

ALTERNATIVES TO 1/2" DIA. ANCHOR BOLT:
 (1) 1/2" DIA. THREADED ROD EPOXY SET W/ 4 1/2" EMBED. (MIN UTILIZING HILTI HY200 EPOXY ANCHORING SYSTEM (OR EQUAL)

1 GARAGE PORTAL FRAME BRACING ELEVATION
 SCALE: N.T.S. BOTH SIDES OF GARAGE DOOR
 120 MPH WIND SPEED (ULT)

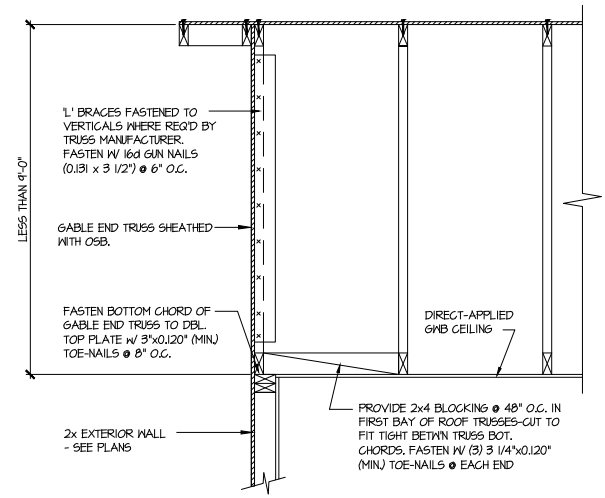
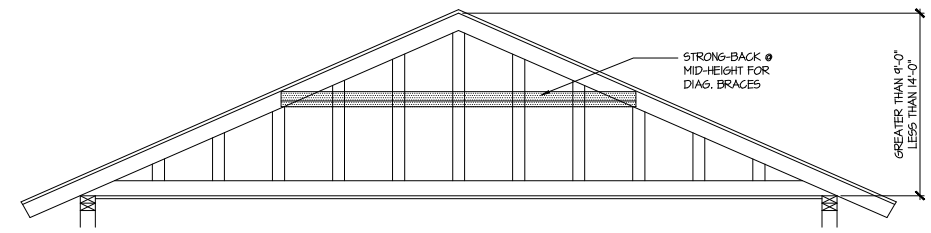
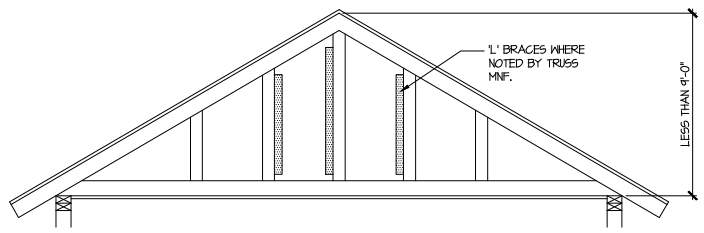

A TYPICAL GABLE END BRACING DETAIL
 SCALE: NONE
 REQ'D @ GABLE END TRUSS HEIGHT UP TO 9'-0"

BRACE GABLE END TRUSSES PER ABOVE DETAIL WHEN GABLE HEIGHT IS LESS THAN 9'-0". L' BRACES REQUIRED WHERE NOTED BY TRUSS MANUFACTURER.

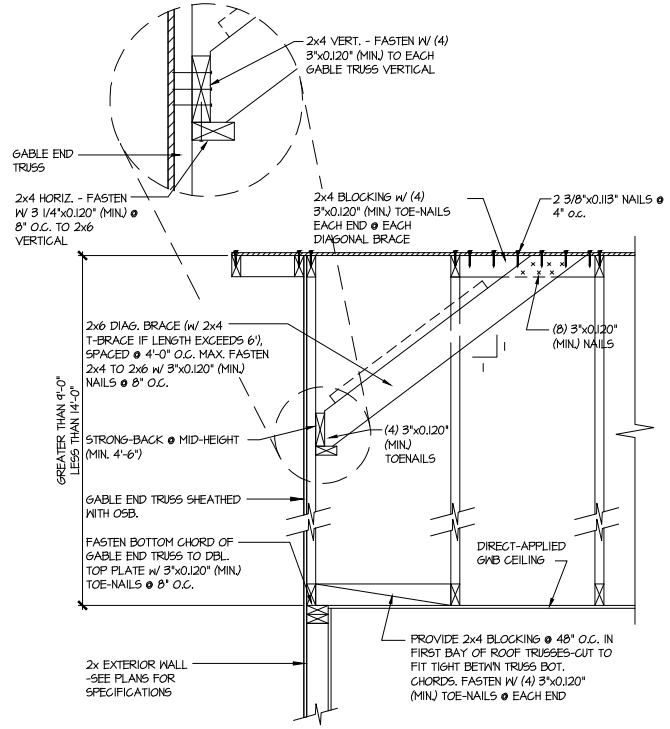

B TYPICAL GABLE END BRACING DETAIL
 SCALE: NONE
 REQ'D @ GABLE END TRUSS HEIGHT BETWEEN 9'-0" TO 14'-0"

BRACE GABLE END TRUSSES PER ABOVE DETAIL WHEN GABLE HEIGHT EXCEEDS 9'-0". L' BRACES NOT REQUIRED.

LETTERED DETAILS ARE TYPICAL FOR THIS HOME & SHALL BE IMPLEMENTED IN ALL APPLICABLE AREAS. THESE DETAILS ARE NOT "CUT" ON THE PLANS.
 NUMBERED DETAILS ARE PLAN SPECIFIC AND ARE ONLY REQUIRED WHERE SPECIFICALLY INDICATED ("CUT") ON THE PLANS.

MULHERN+KULP
 RESIDENTIAL STRUCTURAL ENGINEERING
 3025 Bluebell Parkway, Suite 105 - Alpharetta, GA 30022
 770-777-8874 - mulhern+kulp.com
 NC License # C-3825

Mulhern+Kulp project number:
 256-22018
 project mgr: SMK
 drawn by: RAP
 issue date: 01.05.2023

REVISIONS:
 date: initial:

SMITH DOUGLAS
 HOMES

FRAMING DETAILS
 GRAYSON MODEL
 120 MPH WIND ZONE
 NORTH CAROLINA

BRIARWOOD
 Lot 37

sheet:
SD2.1

72416321 37 BRIARWOOD BLUFF

THIS IS A TRUSS PLACEMENT DIAGRAM (TPD) ONLY; NOT AN ENGINEERED DOCUMENT. Trusses are designed as individual building components to be incorporated into the building design at the specification of the building designer. See individual truss design drawings (TDDs) for each truss design identified on the TPD. The Contractor is responsible for the temporary bracing of the roof and floor system, and the building designer is responsible for the permanent bracing of the roof and floor system. The design of the support structure including but not limited to headers, beams, walls, and columns is also the responsibility of the building designer. For general guidance regarding installation and bracing, consult "Building Component Safety Information" (BCSI) available from the SBC Association (www.sbcassociation.com). It is the responsibility of the General Contractor to verify that the provided component layout matches the final intended construction plans, loading conditions, and use. If they do not, it is the responsibility of the General Contractor to notify UFP and provide plans containing the latest specifications and designs. UFP will not be responsible for plan changes by others after final approval of shop drawings, or for errors or modifications made on-site during construction. DO NOT CUT, NOTCH, DRILL, OR OTHERWISE "REPAIR" MANUFACTURED TRUSSES IN ANY WAY WITHOUT PRIOR WRITTEN AUTHORIZATION BY A LICENSED PROFESSIONAL DESIGNATED BY UFP. The Framing is responsible to verify all dimensions, including adjusting member spacing within tolerances to allow for the drop and rise of plumbing/HVAC, unless noted otherwise. Truss-to-wall connections, if shown, are for uplift only and do not consider lateral loads. All connectors on this project are to be installed per the connector manufacturer's specifications. All connectors shown that are not truss-to-truss are suggestions only and are to be verified by the Building Designer or Engineer of Record for suitability to this particular project. UFP accepts no responsibility for the specific application or suitability of any connector that is not truss-to-truss as they apply to this specific structure.

PLACEMENT PLAN

Products						
Fab Type	Net Qty	Plies	Product	Length	PlotID	
MFD	2	2	1 3/4" x 9 1/4" 2.0E Microllam® LVL	10' 0"	BM1	Ⓜ

INSTALL A 2 X 6 ON TOP RIBBON NOTCH OF C SERIES TRUSSES FOR REAR TRUSSES TO BEAR ON

INSTALL A 2 X 6 ON FLOOR TRUSSES AFTER SHEATHED FOR C SERIES TRUSSES TO BEAR ON (BLOCK SOLID UNDER C03 GIRDERS DOWN TO WALL)

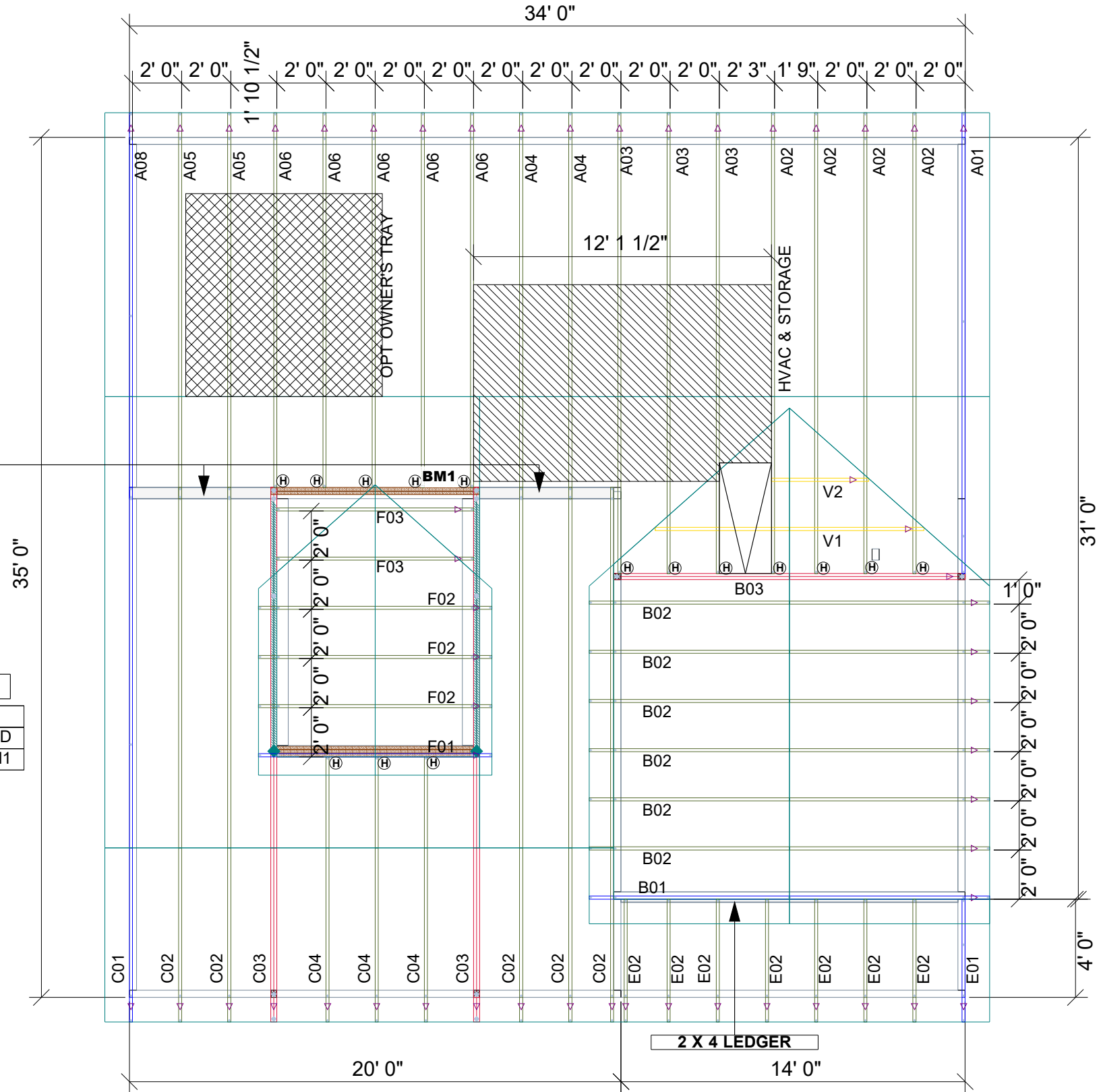

△ INDICATES LEFT END OF TRUSS SCALE: N.T.S.

REVISIONS	DATE	DESCRIPTION	DSN

DESIGNER: HATHCOCK
 LAYOUT DATE: 11/22/2023
 ARCH DATE: -
 STRUC DATE: -
 JOB #: -MASTER

-SMITH DOUGLAS

-GRAYSON ROOF BEH LH

This drawing is property of UFP Site Built, LLC. Any unauthorized use of this document without written permission is prohibited. UFP relinquishes ownership of delivered product upon delivery. Owner of product must obtain UFP's authorization prior to any alteration or modification of product. UFP will not be held responsible for any unauthorized modifications done or costs incurred without prior written authorization from UFP.



UFP SITE BUILT
 A UFP INDUSTRIES COMPANY

Burlington, NC
 Locust, NC
 Chesapeake, VA
 Liberty, NC
 Clinton, NC
 Ooltewah, TN
 Pearisburg, VA
 Conway, SC
 Jefferson, GA
 Stanfield, NC

Customer Service (800) 476-9356

THIS IS AN ENGINEERED WOOD PRODUCT (EWP) MEMBER PLACEMENT DIAGRAM ONLY; NOT AN ENGINEERED DOCUMENT. EWP members are designed as individual building components to be incorporated into the building design at the specification of the building designer. The Contractor is responsible for the temporary bracing of the floor system, and the building designer is responsible for the permanent bracing and blocking of the floor system and the overall structure. The design of the support structure including but not limited to headers, beams, walls, and columns is also the responsibility of the building designer. It is the responsibility of the General Contractor to notify UFP and provide plans containing the latest specifications and designs. UFP will not be responsible for plan changes by others after final approval of shop drawings, or for errors or modifications made on-site during construction. DO NOT CUT, NOTCH, DRILL, OR OTHERWISE "REPAIR" EWP MEMBERS IN ANY WAY WITHOUT PRIOR WRITTEN AUTHORIZATION BY A LICENSED PROFESSIONAL DESIGNATED BY UFP. The Framing is responsible to verify all dimensions, including adjusting member spacing within tolerances to allow for the drop and rise of plumbing/HVAC, unless noted otherwise. All connectors on this project are to be installed per the connector manufacturer's specifications. All connectors shown that are not joist to joist are suggestions only and are to be verified by the Building Designer or Engineer of Record for suitability to this particular project. UFP accepts no responsibility for the specific application or suitability of any connector that is not joist to joist as they apply to this specific structure.

2ND FLOOR PLACEMENT PLAN

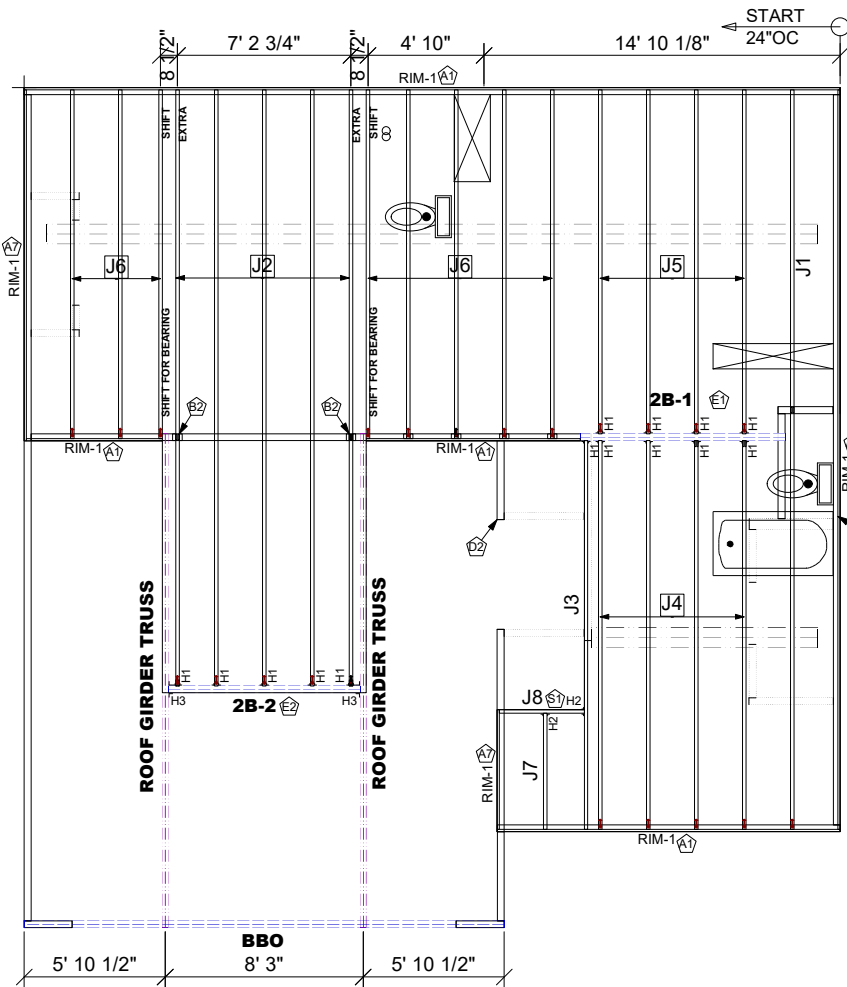
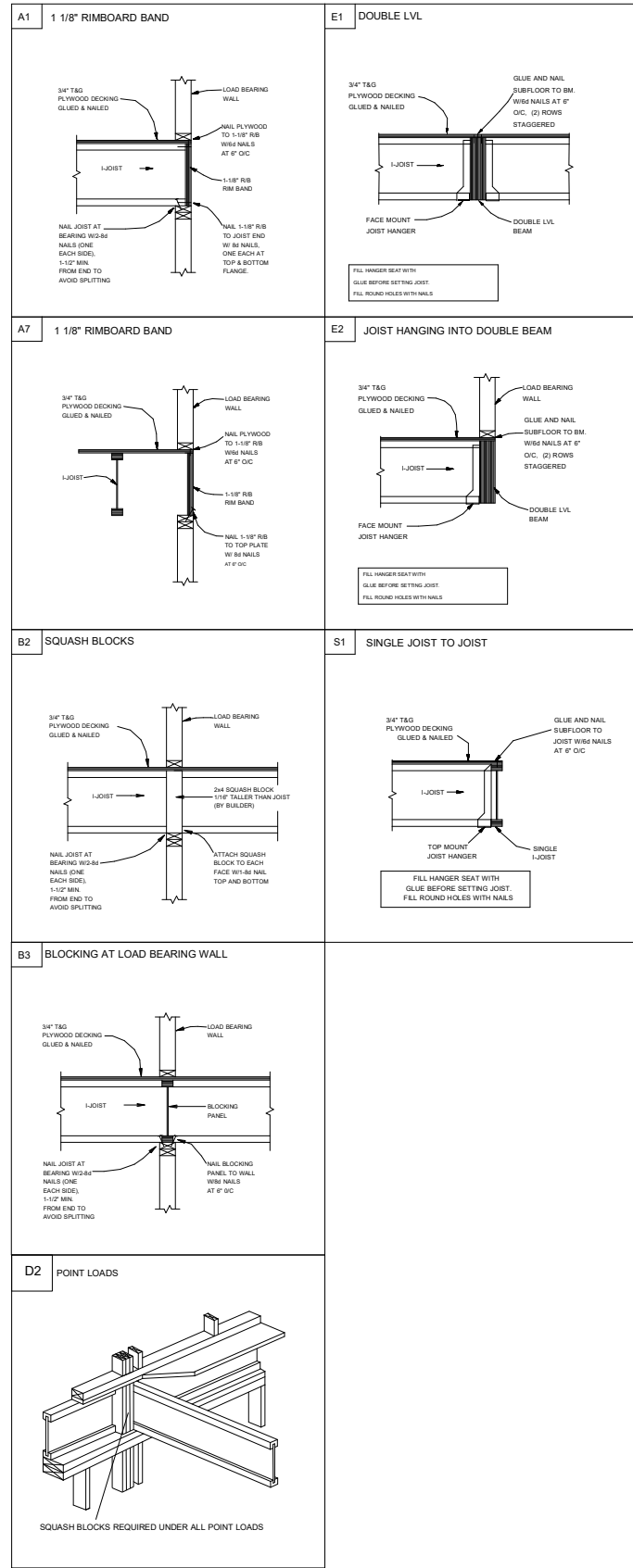

RED END THIS SIDE!
EXTIMO ROJA AQUI !!!!

FIELD TRIM NON RED END TO KEEP HOLES ALIGNED
CONTAR EL LADO DE SIN MARCA ROJA PARA HOYOS ALINEADOS

Products					
PlotID	Length	Product	Plies	Net Qty	Fab Type
J1	31' 0"	14" TJI@ 110	1	1	MFD
J2	25' 0"	14" TJI@ 110	1	5	MFD
J3	17' 0"	14" TJI@ 110	1	1	MFD
J4	17' 0"	14" TJI@ 110	1	4	MFD
J5	15' 0"	14" TJI@ 110	1	4	MFD
J6	15' 0"	14" TJI@ 110	1	8	MFD
J7	5' 0"	14" TJI@ 110	1	1	MFD
J8	4' 0"	14" TJI@ 110	1	1	MFD
2B-1	9' 0"	1 3/4" x 14" 2.0E Microllam® LVL	2	2	MFD
2B-2	8' 0"	1 3/4" x 14" 2.0E Microllam® LVL	2	2	MFD
RIM-1	16' 0"	1 1/8" x 14" TJ@ Rim Board	1	8	MFD

Connector Summary			
PlotID	Qty	Manuf	Product
H1	14	MiTek	IHFL1714
H2	2	MiTek	TFL1714
H3	2	MiTek	HD412IF

GENERAL NOTES:

- 1.) TOP CHORD OF JOISTS ARE PAINTED RED AT NUMBERED END. PLACE PAINTED END AS NOTED ON PLAN.
- 2.) FOLLOW SPECIAL SPACING AND LOCATION DIMENSIONS FOR EXTRAS OR SHIFTED JOISTS AS SHOWN ON PLAN.
- 3.) ALL INTERIOR WALL PLATES MUST BE LEVEL WITH OUTSIDE WALL TOP PLATES.
- 4.) DO NOT STACK CONSTRUCTION LOADS ON UN-BRACED JOISTS.
- 5.) PROVIDE SOLID SUPPORT BELOW ALL BEAM AND HEADER BEARING POINTS IN WALL AND JOIST SPACES CONTINUOUS DOWN TO THE FOUNDATION.
- 6.) LOCATE CRIPPLE STUDS IN JOIST SPACE DIRECTLY BELOW HEADER JACKS AT ALL FIRST FLOOR EXTERIOR DOOR LOCATIONS.
- 7.) INSTALL NAILS IN ALL HOLES PROVIDED IN JOIST HANGERS EXCEPT AT BOTTOM CHORD SEAT. PLACE A DAB OF GLUE IN THE HANGER SEAT BEFORE SETTING JOISTS.
- 8.) IMPORTANT NOTE! NO STRUCTURAL ANALYSIS OF CONVENTIONAL HEADERS HAS BEEN CONDUCTED IF NOT NOTED. THEY ARE CONSIDERED TO BE ADEQUATE TO SUPPORT THE APPLIED LOADS.

FRAMER NOTE

--- DENOTES DUCT HOLE RUNS

ALL DIMENSIONS TO CENTERLINE UNLESS OTHERWISE NOTED

• Avoid Plumbing Drops

FRAMER NOTE

1. GLUE AND NAIL PLYWOOD SUBFLOOR TO BEAMS AND GIRDERS AT 6" O/C WHERE NO WALL IS ABOVE.
2. FILL HANGER SEAT WITH GLUE BEFORE SETTING JOIST IN HANGER. FILL ROUND HOLES WITH NAILS.

CRITICAL !!

INSTALL 2X4 SQUASH BLOCKS IN FLOOR TRUSS SPACE BELOW ALL EXTERIOR DOOR HEADER JACKS. CUT 1/16" TALLER THAN TRUSS.

FIELD VERIFY DIMENSIONS TO JOISTS LOCATED UNDER WALLS!!

2ND FLOOR LAYOUT

PLAN LEGEND

- 1B-, 2B-** *INDICATES BEAM ABOVE TOP PLATE (FLUSH WITH FLOOR SYSTEM)
- H-, 1H-, GDH-** *INDICATES BEAM BELOW TOP PLATE (DROPPED BELOW FLOOR SYSTEM)
- *BEAMS MAY PROTRUDE ABOVE OR BELOW DECKING OR TOP PLATE RESPECTIVELY, REFER TO DETAIL IF BEAM IS A DIFFERENT DEPTH THAN FLOOR SYSTEM
- SINGLE PLY BEAM (ADD LINE FOR EACH ADDITIONAL PLY)
 - SHIFT: SHIFT JOIST TO MISS PLUMBING, ALIGN W/WALL OR SUPPORT FURNITURE
 - EXTRA: A JOIST ADDED TO THE LAYOUT IN ADDITION TO THE ON CENTER JOISTS
 - DOUBLE: TWO JOISTS SIDE BY SIDE (ONLY ASSEMBLED IF NOTED)

FIELD TRIM NON RED END TO KEEP HOLES ALIGNED
CONTAR EL LADO DE SIN MARCA ROJA PARA HOYOS ALINEADOS

FIELD LOCATE PLUMBING DROPS/CAN LIGHTS, ETC... PRIOR TO JOIST SECUREMENT TO AVOID INTERFERENCE.

LAYOUT FOR 19.2" O/C

1= 19-3/16"	9= 172-13/16"
2= 38-3/8"	10= 192"
3=57-5/8"	11= 211-3/16"
4= 76-13/16"	12= 230-3/8"
5= 96"	13= 249-13/16"
6= 115-3/16"	14= 268-13/16"
7= 134-3/8"	15= 288"
8= 153-5/8"	

REVISIONS	DATE	DESCRIPTION	DSN

DESIGNER PB2
LAYOUT DATE 5/17/2024
ARCH DATE 10/21/2023
STRUC DATE 2/6/2023

JOB #: 24051536F2

SCALE: 1/8" = 1'

Smith Douglas Homes

Grayson 2nd Floor



TRUSS TRAX
UP CONSTRUCTION

This drawing is property of UFP Site Built, LLC. Any unauthorized use of this document without written permission is prohibited. UFP relinquishes ownership of delivered product upon delivery. Owner of product must obtain UFP's authorization prior to any alteration or modification of product. UFP will not be held responsible for any unauthorized modifications done or costs incurred without prior written authorization from UFP.

UFP SITE BUILT
A UFP INDUSTRIES COMPANY

Burlington, NC
Chesapeake, VA
Clinton, NC
Conway, SC
Jefferson, GA
Locust, NC
Liberty, NC
Ooltewah, TN
Pearisburg, VA
Stanfield, NC

Customer Service (800) 476-9356