

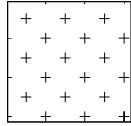

1. ALL MATERIAL IS 2x4
2. THIS DETAIL IS APPLICABLE FOR DESIGNS WITH DOLS. OF 1.15 OR 1.25 AND LUMBER SPECIES SP, DF, HF, OR SPF.
3. DETAIL SHALL BE USED FOR CONDITIONS OF A MISSING OR LOOSE CONNECTOR PLATE ONLY.
4. CHORD MATERIAL IS CONTINUOUS THROUGH JOINT, THERE IS NO MAXIMUM CHORD FORCE AND NO SPLICE PERMITTED.
5. REFER TO MITEK DESIGN DRAWING FOR WEB FORCES.

Lot 36 Birchwood SP01



ATTACH 1/2" PLYWOOD OR OSB GUSSET (15/32" RATED SHEATHING 32/16 EXP 1) TO EACH FACE OF TRUSS WITH (0.131" X MIN 2.5") NAILS IN 3 ROWS SPACED @ 4" O.C. NAILS TO BE DRIVEN FROM BOTH FACES. STAGGER SPACING FROM FRONT TO BACK FACE FOR A NET 2" O.C. SPACING IN THE TRUSS. USE 2" MEMBER END DISTANCE.

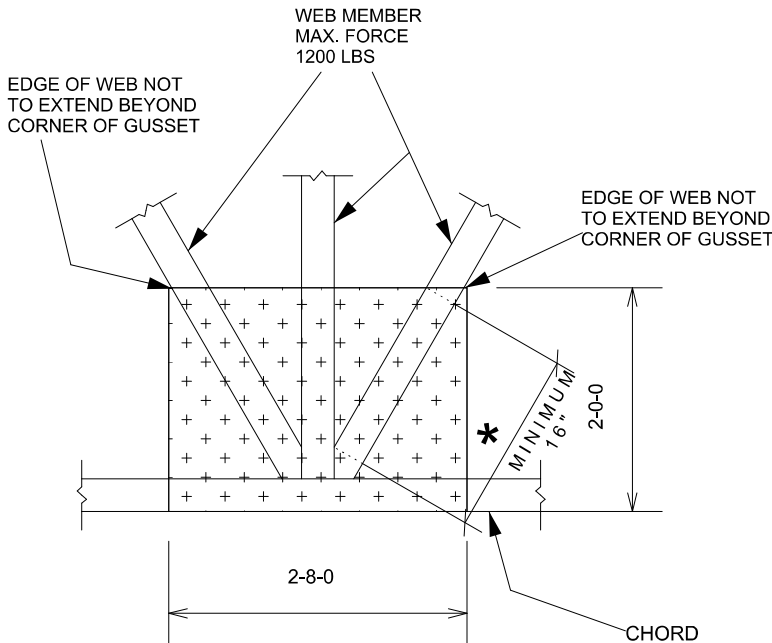
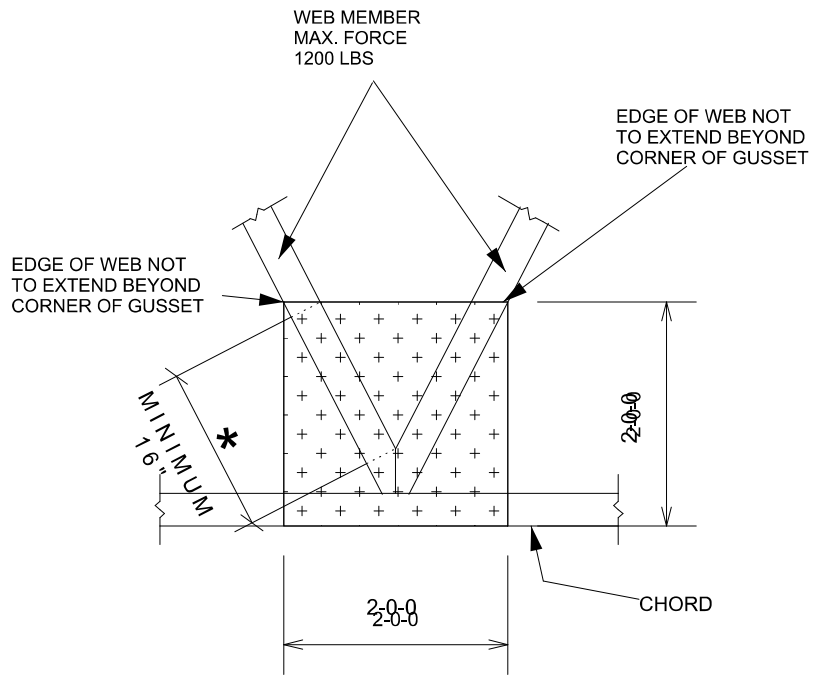
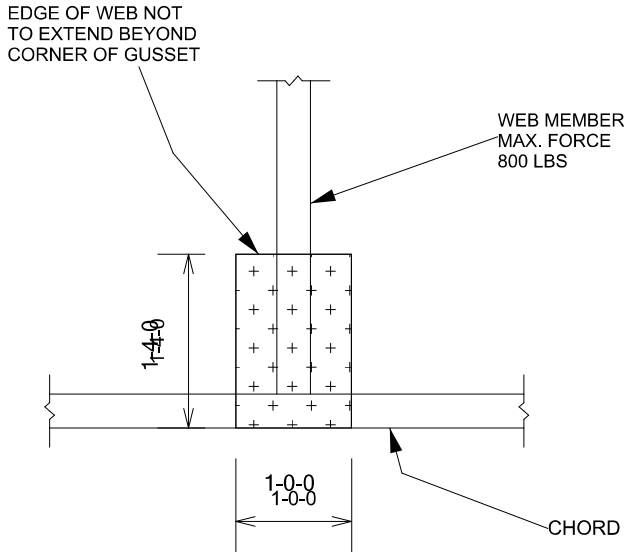

\* MEASUREMENT TAKEN AT POINTS WHERE WEB ACHIEVES FULL MEMBER DEPTH (AS MEASURED PERPENDICULAR TO WEB'S SAW-MILLED EDGE)



January 12, 2024

**WARNING - Verify design parameters and READ NOTES ON THIS AND INCLUDED MITEK REFERENCE PAGE MII-7473 rev. 1/2/2023 BEFORE USE.**  
 Design valid for use only with MiTek® connectors. This design is based only upon parameters shown, and is for an individual building component, not a truss system. Before use, the building designer must verify the applicability of design parameters and properly incorporate this design into the overall building design. Bracing indicated is to prevent buckling of individual truss web and/or chord members only. Additional temporary and permanent bracing is always required for stability and to prevent collapse with possible personal injury and property damage. For general guidance regarding the fabrication, storage, delivery, erection and bracing of trusses and truss systems, see **ANSI/TPI1 Quality Criteria and DSB-22** available from Truss Plate Institute ([www.tpinst.org](http://www.tpinst.org)) and **BCSI Building Component Safety Information** available from the Structural Building Component Association ([www.sbcacomponents.com](http://www.sbcacomponents.com))



818 Soundside Road  
Edenton, NC 27932