

RETAINING WALL DESIGN FOR PROVIDENCE CREEK ANGIER, NORTH CAROLINA

Plan Sheet Index:

- RW-1 Title Sheet***
- RW-2 Retaining Wall Layout***
- RW-3 Retaining Wall #1a & 1b Profiles***
- RW-4 Retaining Wall #2 Profiles***
- RW-5 Retaining Walls #3a & #3b Profiles***
- RW-6 Retaining Walls #4 and #5 Profiles***
- RW-7 Diamond Pro PS Unit Details***
- RW-8 Specifications***

Special Inspection and Material Testing Items			
RETAINING WALL CONSTRUCTION (IBC 1806.2)			
Item			Detailed Instructions and Frequencies
Verify the properties of the in-place and proposed soil materials	<input type="checkbox"/> Continuous	<input checked="" type="checkbox"/> Periodic	Materials shall meet the assumed design values in Section 1.2 of the Specifications
Verify the suitability of in-place and proposed soil materials	<input type="checkbox"/> Continuous	<input checked="" type="checkbox"/> Periodic	Materials shall meet the requirements of Sections 2.6 and 2.7 of the Specifications
Verify subgrade is adequate to achieve design bearing capacity	<input type="checkbox"/> Continuous	<input checked="" type="checkbox"/> Periodic	Bearing capacity of foundation and reinforced zone shall meet Section 1.3 of the Specifications
Verify leveling pad material and proper depth	<input type="checkbox"/> Continuous	<input checked="" type="checkbox"/> Periodic	Materials shall meet requirements of Sections 2.5 and 9.0 of the Specifications
Verify placement, setback, and connection method of units	<input checked="" type="checkbox"/> Continuous	<input type="checkbox"/> Periodic	Retaining Wall Profiles, Unit Details, and Sections 1.4, 2.2, 3.2, and 3.5 of the Specifications
Verify installation of drainage tile and drainage system	<input checked="" type="checkbox"/> Continuous	<input type="checkbox"/> Periodic	Retaining Wall Unit Details and Specifications
Verify geogrid material, length, and elevation placement	<input checked="" type="checkbox"/> Continuous	<input type="checkbox"/> Periodic	Retaining Wall Profiles and Sections 2.3, 3.3, and 9.0 of the Specifications
Verify density, moisture content, and lift thickness for reinforcing zone fill	<input checked="" type="checkbox"/> Continuous	<input type="checkbox"/> Periodic	Placement of reinforcing zone fill shall meet requirements of Sections 3.4 and 3.6 of the Specifications

A summary of testing services, signed and sealed by a registered professional engineer shall be provided to the Registered Design Professional prior to issuance of the final inspection report.

4905 Professional Court
Raleigh, North Carolina 27609
Phone (919) 876-9799 Fax (919) 876-8291

Registered Design Professional
Justin R. Pescosolido, P.E.

<p>TerraTech Engineers, Inc.</p> <p style="font-size: small;">4905 Professional Court Raleigh, North Carolina 27609 Phone: (919) 876-9799 Fax: (919) 876-8291</p>	<p>Seal</p>	<p>Providence Creek Angier, North Carolina Our Project Number 121-20-103521</p>	<table border="1" style="width: 100%; border-collapse: collapse; font-size: x-small;"> <thead> <tr> <th>REV</th> <th>DATE</th> <th>DESCRIPTION</th> <th>BY</th> </tr> </thead> <tbody> <tr> <td>1</td> <td>1-12-21</td> <td>MSE OVER-HEADWALL ADDED</td> <td>JRP</td> </tr> <tr><td> </td><td> </td><td> </td><td> </td></tr> <tr><td> </td><td> </td><td> </td><td> </td></tr> <tr><td> </td><td> </td><td> </td><td> </td></tr> <tr><td> </td><td> </td><td> </td><td> </td></tr> <tr><td> </td><td> </td><td> </td><td> </td></tr> <tr><td> </td><td> </td><td> </td><td> </td></tr> <tr><td> </td><td> </td><td> </td><td> </td></tr> <tr><td> </td><td> </td><td> </td><td> </td></tr> <tr><td> </td><td> </td><td> </td><td> </td></tr> </tbody> </table>	REV	DATE	DESCRIPTION	BY	1	1-12-21	MSE OVER-HEADWALL ADDED	JRP																																					<p>Title Sheet</p> <table style="width: 100%; font-size: x-small;"> <tr> <td style="width: 60%;">Designed by: Justin R. Pescosolido, P.E.</td> <td style="width: 20%;">Date: 12-16-20</td> <td style="width: 20%; text-align: right;">SHEET</td> </tr> <tr> <td>Drawn By: Justin R. Pescosolido, P.E.</td> <td>Date: 12-16-20</td> <td style="text-align: right;">RW-1</td> </tr> <tr> <td>Reviewed By: Christopher S. Pilz, P.E.</td> <td>Date: 12-16-20</td> <td></td> </tr> </table> <p style="text-align: center; font-weight: bold;">Retaining Wall Design</p>	Designed by: Justin R. Pescosolido, P.E.	Date: 12-16-20	SHEET	Drawn By: Justin R. Pescosolido, P.E.	Date: 12-16-20	RW-1	Reviewed By: Christopher S. Pilz, P.E.	Date: 12-16-20	
REV	DATE	DESCRIPTION	BY																																																						
1	1-12-21	MSE OVER-HEADWALL ADDED	JRP																																																						
Designed by: Justin R. Pescosolido, P.E.	Date: 12-16-20	SHEET																																																							
Drawn By: Justin R. Pescosolido, P.E.	Date: 12-16-20	RW-1																																																							
Reviewed By: Christopher S. Pilz, P.E.	Date: 12-16-20																																																								

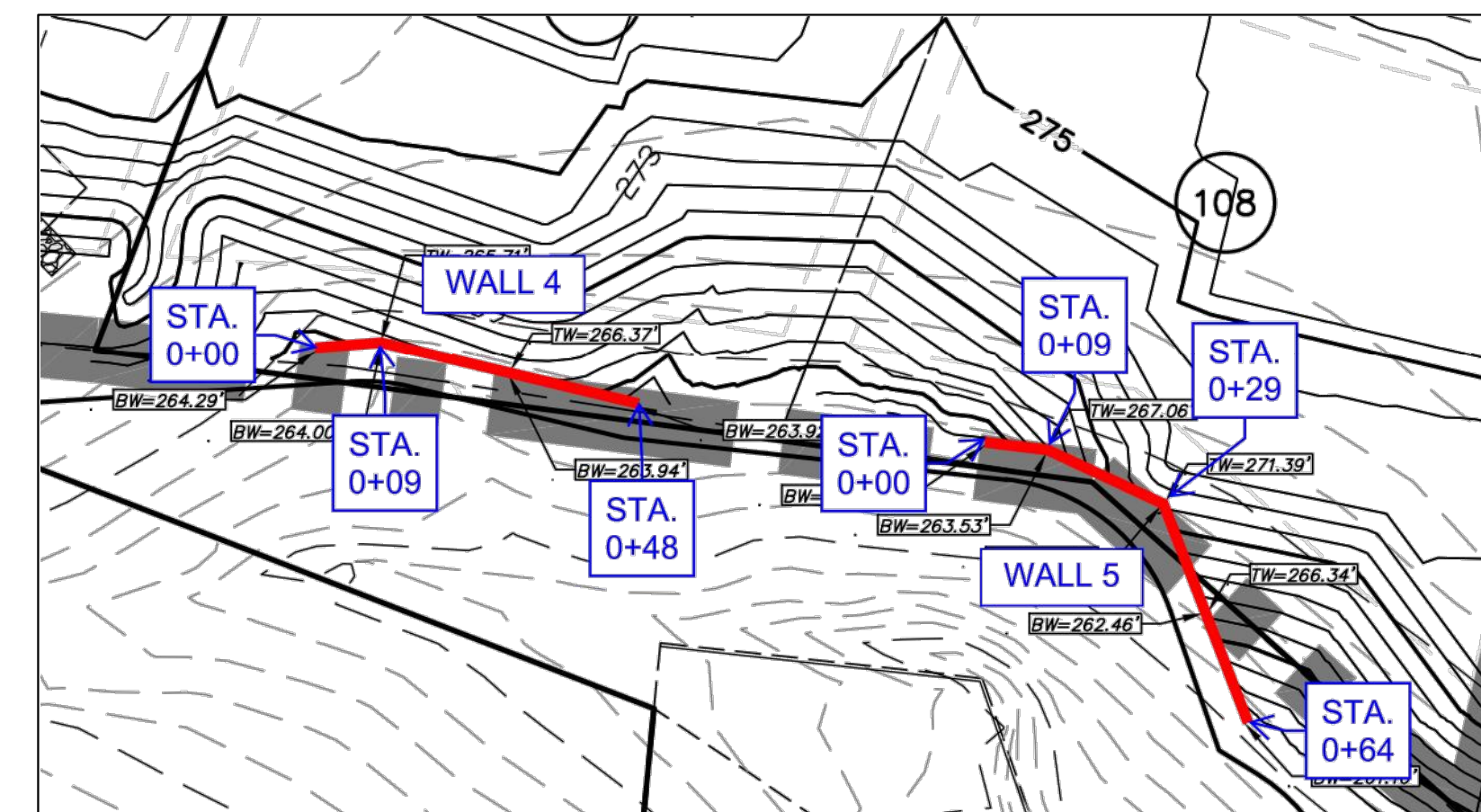
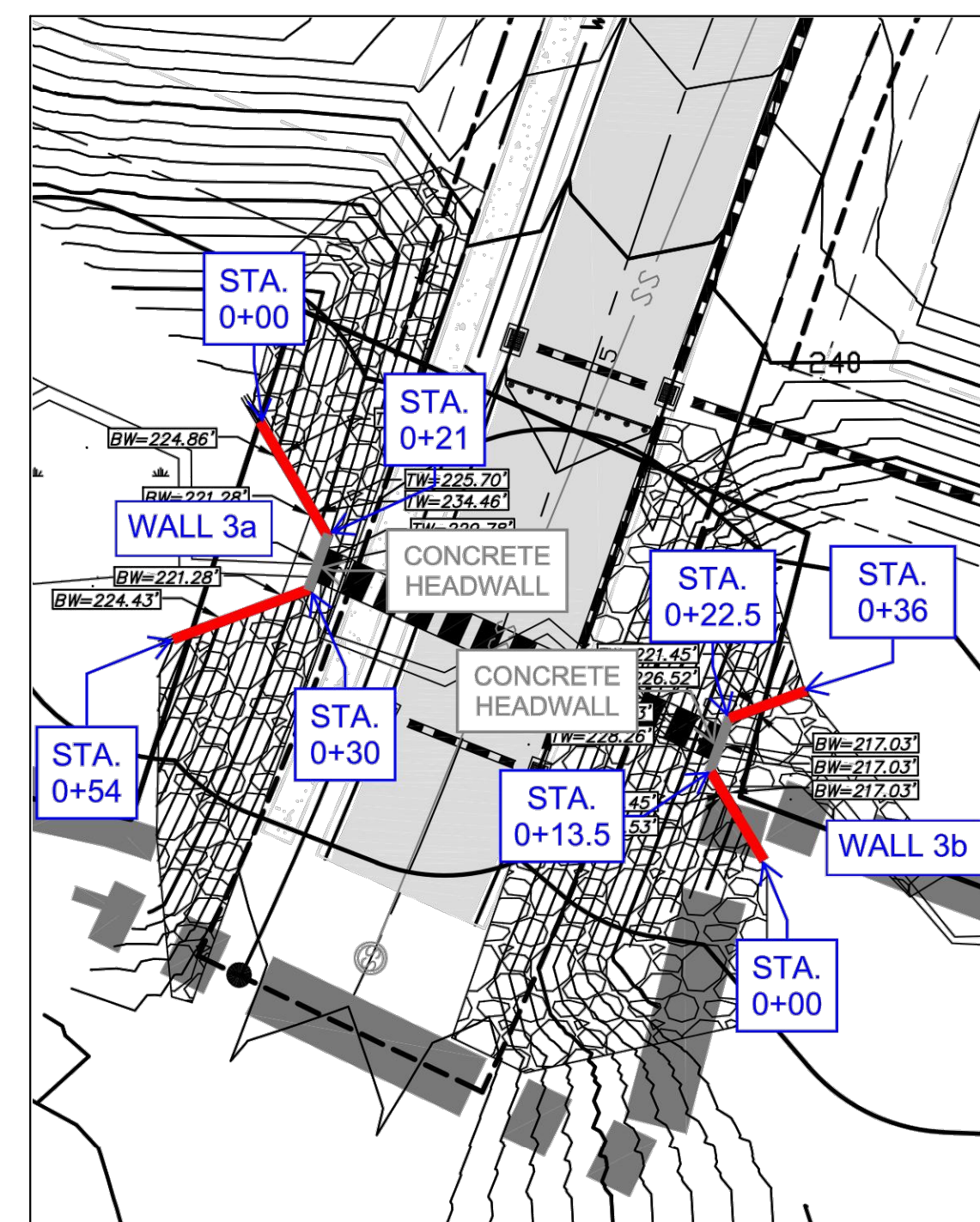
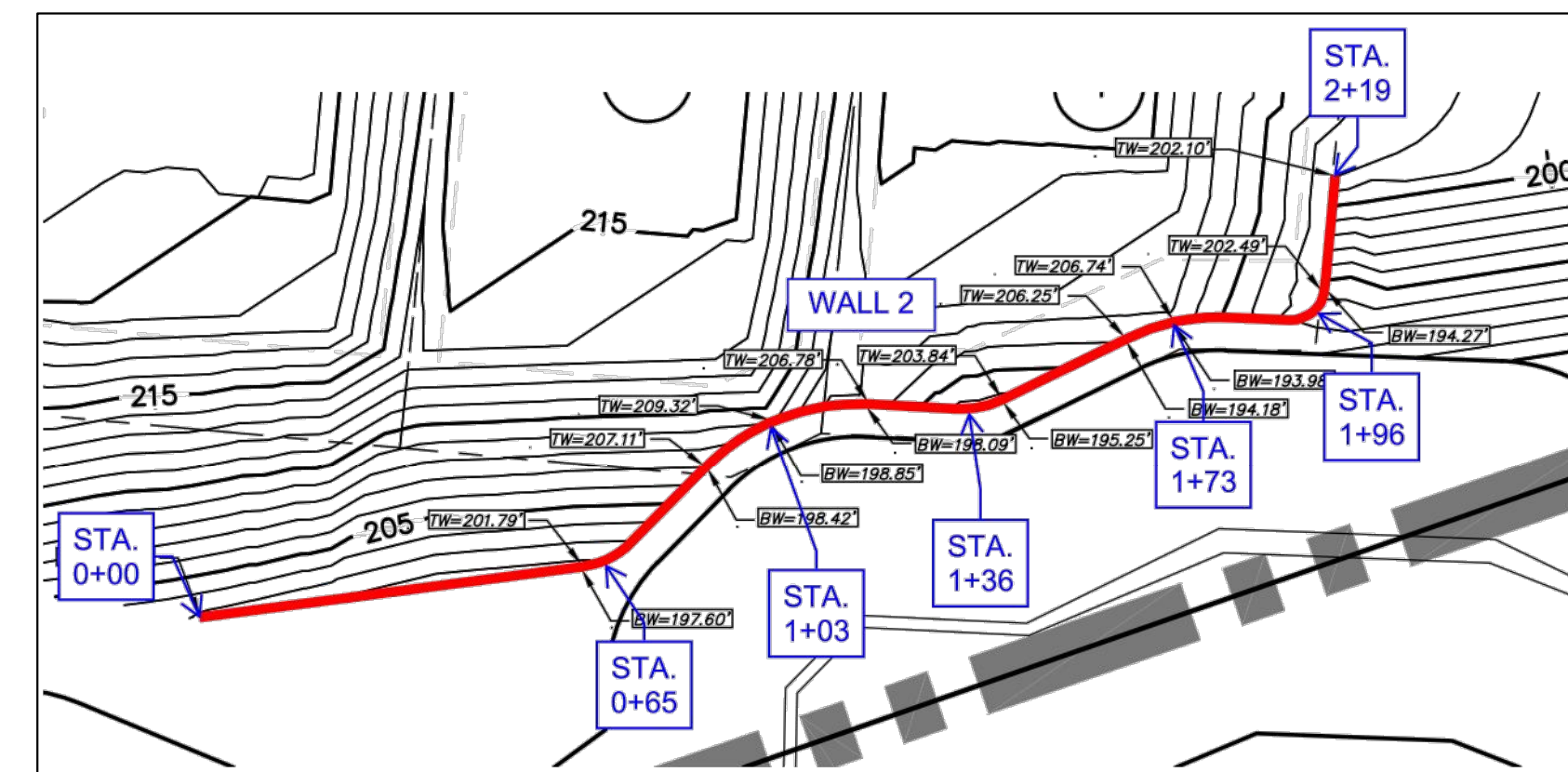
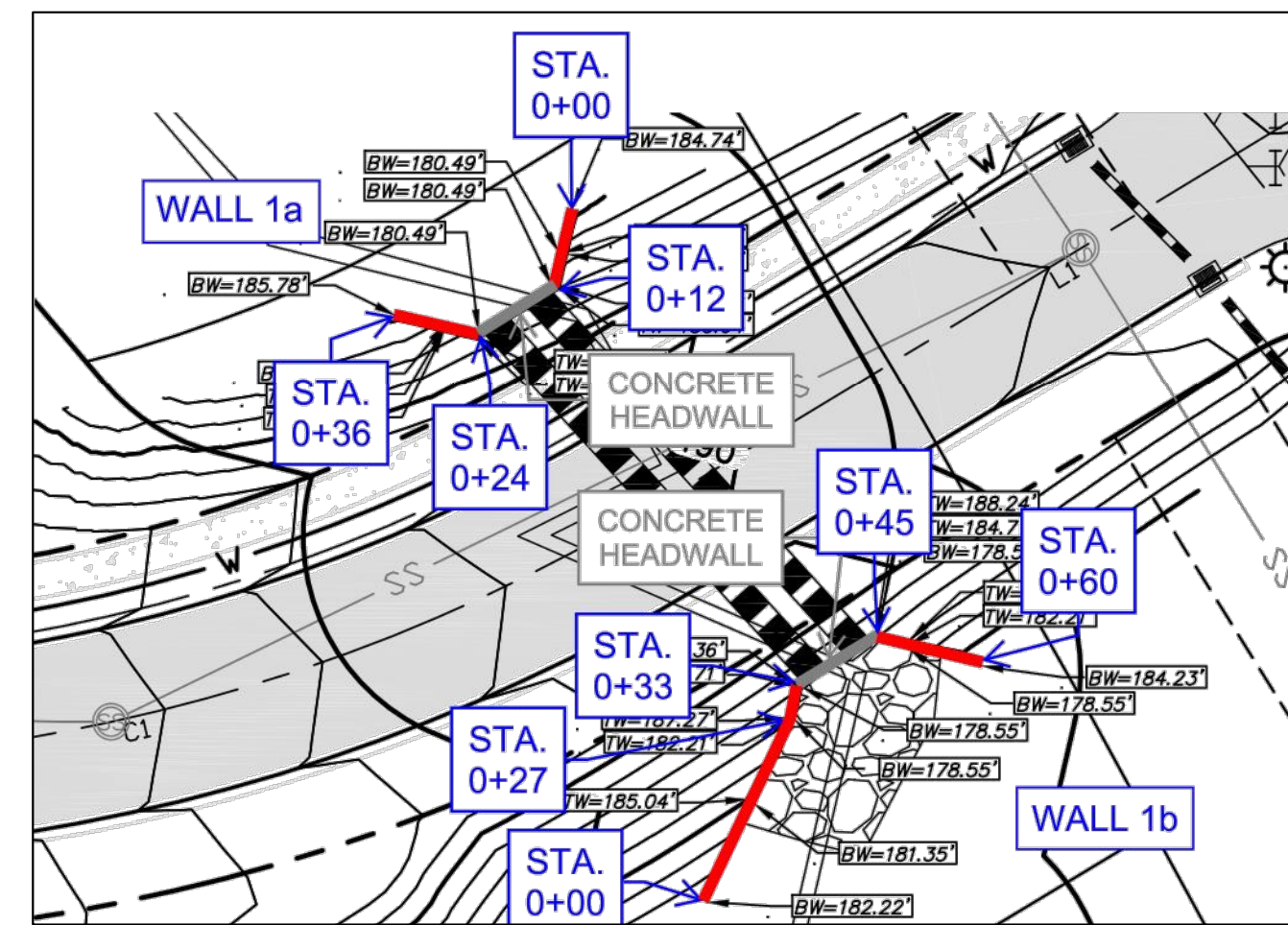

SITE LAYOUT FIGURES AND WALL ELEVATIONS WERE PROVIDED BY MCKIM & CREED AND SHOULD BE CONSIDERED APPROXIMATE. ACTUAL WALL LOCATIONS SHALL BE STAKED IN THE FIELD BY A QUALIFIED SURVEYOR BASED ON THE SITE/CIVIL DRAWINGS PRIOR TO CONSTRUCTION.

General Notes

These retaining walls have been designed using active earth pressure theory. Therefore, outward movement at the tops of the walls should be expected. Wall movement may be limited by using high quality fill soils with a low fines content in the reinforced zone. Some cracks could develop at the ground surface due to lateral movement of the walls. These cracks should be filled in as soon as they are observed to help protect the soils below the ground surface from softening related to water infiltration that could affect the support characteristics for adjacent construction.

Preliminary analyses for global stability and total and differential settlement were performed as part of the design services for these segmental retaining walls. Our analyses were based, in part, on assumed in-situ soil properties derived from our previous experience with similar construction in close geographic proximity and our previous experience providing construction materials testing services at this site. However, we have not performed soil test borings to verify the assumed soil properties. If soil conditions encountered during construction are different than those assumed herein, TerraTech Engineers shall be contacted immediately for review of and possible alterations to this design.

The Engineer requests that representatives of the owner and/or general contractor arrange a pre-construction meeting with all pertinent parties involved for the construction of the retaining walls shown on these plans. The Engineer's responsibility is limited to providing only the design services of the project's retaining walls contained herein. Retaining wall construction monitoring and retaining wall certifying are beyond the scope of these design services.

These walls were designed using no additional dead or live loading surcharge conditions and no additional lateral loading surcharge conditions. Structures such as light poles, handrail, guardrail, or drainage structures to be installed in the vicinity of the retaining walls shall be designed and constructed to resist imposing additional lateral loads on any retaining wall. If future construction alters the assumed loading conditions of any retaining wall, TerraTech Engineers, Inc. shall be notified to review the design criteria for the imposed loads.

We note that scour protection (Designed by Others, "DBO") is required where indicated along the base of Retaining Walls 1a, 1b, 2, 3a, and 3b. Scour protection design shall be specified by the site/civil engineer of record.

Construction Notes

- Prior to construction, confirmation of the distances to property lines, Tree Buffers, roadways, sidewalks, and/or curb and gutter to the face of the proposed walls shall be performed.
- Prior to construction, confirmation of existing utility line locations (Stormwater, Sewer, Water, Electrical, and Gas) and the locations of future utility lines shall be performed.
- Prior to construction, confirmation of the in-situ and proposed grades shall be performed by a licensed surveyor. TerraTech Engineers, Inc. shall be notified if the site grades are different than those shown on these drawings.
- During construction, care must be exercised to prevent the undermining of any existing structures. Conversely, construction of adjacent structures, including pavements, shall be constructed in such a manner as to avoid damaging the geogrid reinforcement of any retaining wall.
- Utility structures and underground lines located within the reinforced zone of retaining walls shall be installed prior to or during construction of the retaining wall to prevent damage to the reinforcement layers. If the presence of utility structures interferes with the integrity of the reinforcement, TerraTech Engineers, Inc. shall be notified immediately.
- After construction, heavy equipment should not operate within 3 feet of the top portion of any wall to prevent adverse impacts to the structural integrity of the retaining wall.
- After construction, care must be exercised to prevent damage to the upper layers of reinforcement and degrading of the retained soils of the retaining walls. Installation of light poles, signs, handrails, guardrails, shrubs, or trees (etc.) in the reinforced zone of any retaining wall shall not damage the upper layers of reinforcement. Any damaged reinforcement shall be repaired. Trees or other vegetation with significant root growth size shall not be present within 5 feet of the top of any wall to prevent damage to the upper courses of the wall. Furthermore, backfill of any utility ditches or other excavations that occur after wall construction should be backfilled immediately to prevent infiltration into the reinforced, retained, and/or foundation zones of any wall.
- Surface water drainage shall be designed by others to discharge surface water away from the wall faces and away from adjacent structures and/or pavements. We note that scour protection (Designed by Others, "DBO") is required where indicated along the base of Retaining Walls 1a, 1b, 2, 3a, and 3b. Scour protection design shall be specified by the site/civil engineer of record. Maintaining drainage provisions shown herein is critical to long term wall performance.
- Temporary re-routing and/or removal of any surface water in the areas of planned retaining wall construction is solely the responsibility of the contractor.

TerraTech Engineers, Inc.

4905 Professional Court
Raleigh, North Carolina 27609
Phone: (919) 876-9799 Fax: (919) 876-8291

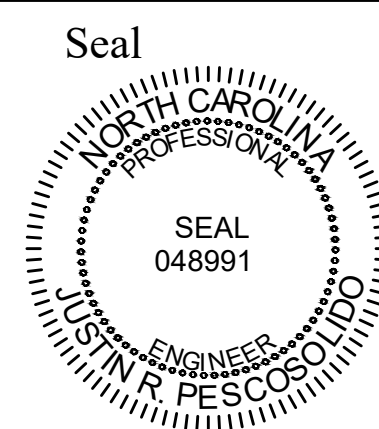

Providence Creek
Angier, North Carolina
Our Project Number 121-20-103521

REV	DATE	DESCRIPTION	BY
1	1-12-21	MSE OVER-HEADWALL ADDED	JRP

Retaining Wall Layout

Designed by: Justin R. Pescosolido, P.E.	Date: 12-16-20	SHEET RW-2
Drawn By: Justin R. Pescosolido, P.E.	Date: 12-16-20	
Reviewed By: Christopher S. Pilz, P.E.	Date: 12-16-20	
Retaining Wall Design		

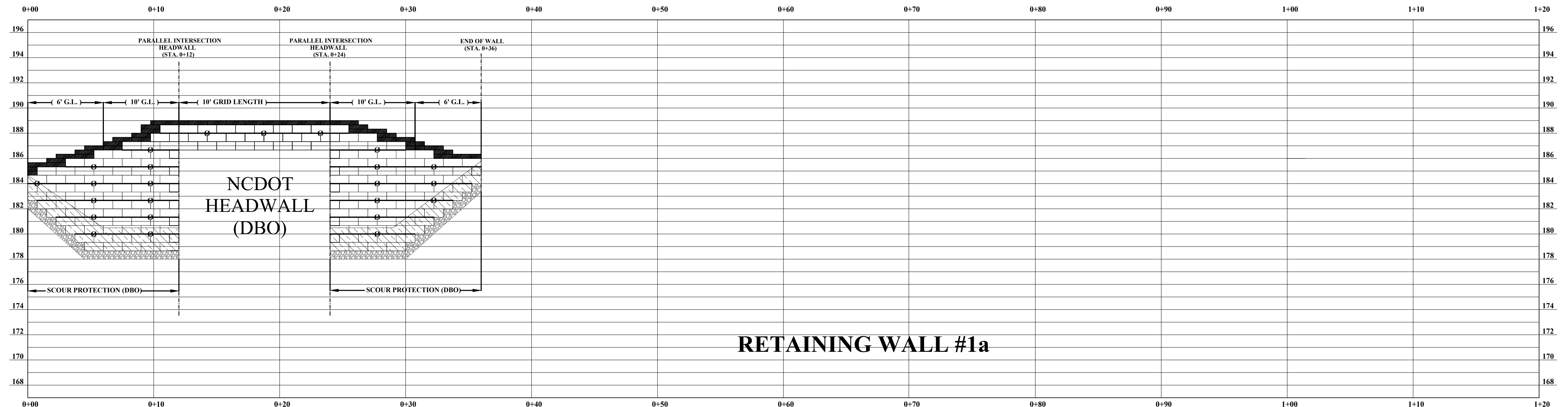

RETAINING WALL #1a

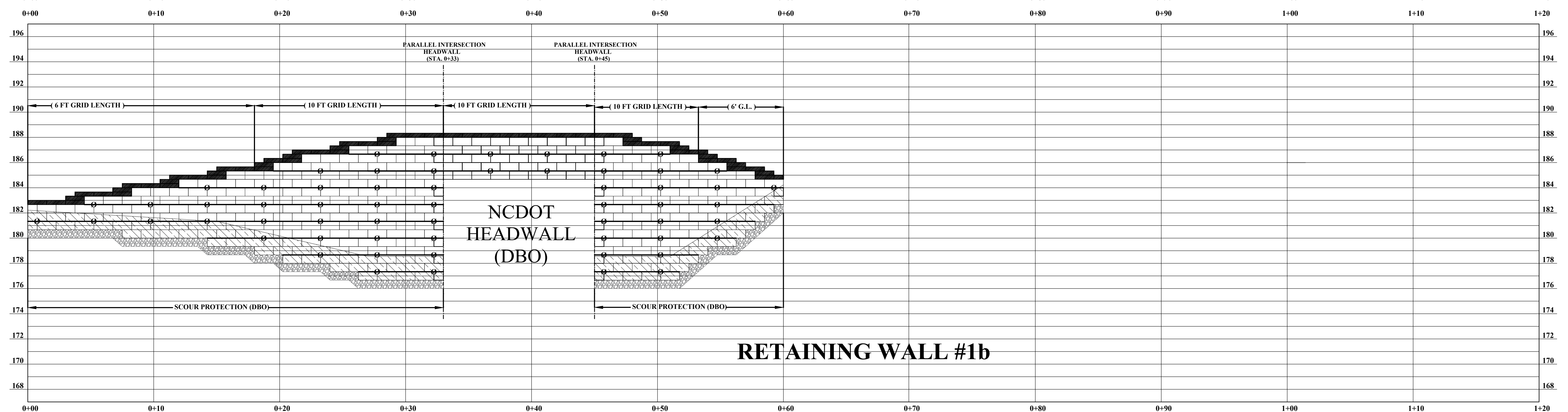

RETAINING WALL #1b

NOTE: RETAINING WALLS #1a AND #1b TO BE CONSTRUCTED WITH WASHED NO. 57 STONE WITHIN REINFORCED ZONE (ENTIRETY OF WALLS)

NOTE: ONE (1) #4 BAR @ 36" O.C. SHALL BE DRILLED AND EPOXIED (6" EMBEDDED, MIN) INTO THE TOP OF THE CONCRETE HEADWALL UTILIZING HILTI HIT-HY 200 (OR APPROVED EQUIVALENT). DOWEL SHALL EXTEND THROUGH ALL COURSES OF SEGMENTAL BLOCK WALL ABOVE. COURSES ENCLOSING DOWEL SHALL BE GROUTED SOLID.

- LEGEND:
- 1). STRATA SG-200 GEOGRID DESIGNATION
 - 2). EMBEDDED BLOCK DESIGNATION
 - 3). EMBEDDED BLOCK DESIGNATION
 - 4). LEVELING PAD DESIGNATION

TerraTech Engineers, Inc.

4905 Professional Court
 Raleigh, North Carolina 27609
 Phone: (919) 876-9799 Fax: (919) 876-8291

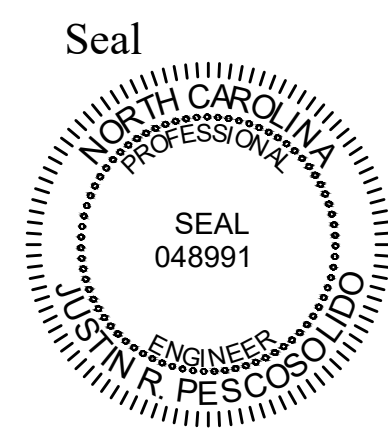

Providence Creek
 Angier, North Carolina
 Our Project Number 121-20-103521

REV	DATE	DESCRIPTION	BY
1	1-12-21	MSE OVER-HEADWALL ADDED	JRP

Retaining Wall #1a & #1b Profiles

Designed by: Justin R. Pescosolido, P.E.	Date: 12-16-20	SHEET RW-3
Drawn By: Justin R. Pescosolido, P.E.	Date: 12-16-20	
Reviewed By: Christopher S. Pilz, P.E.	Date: 12-16-20	
Retaining Wall Design		

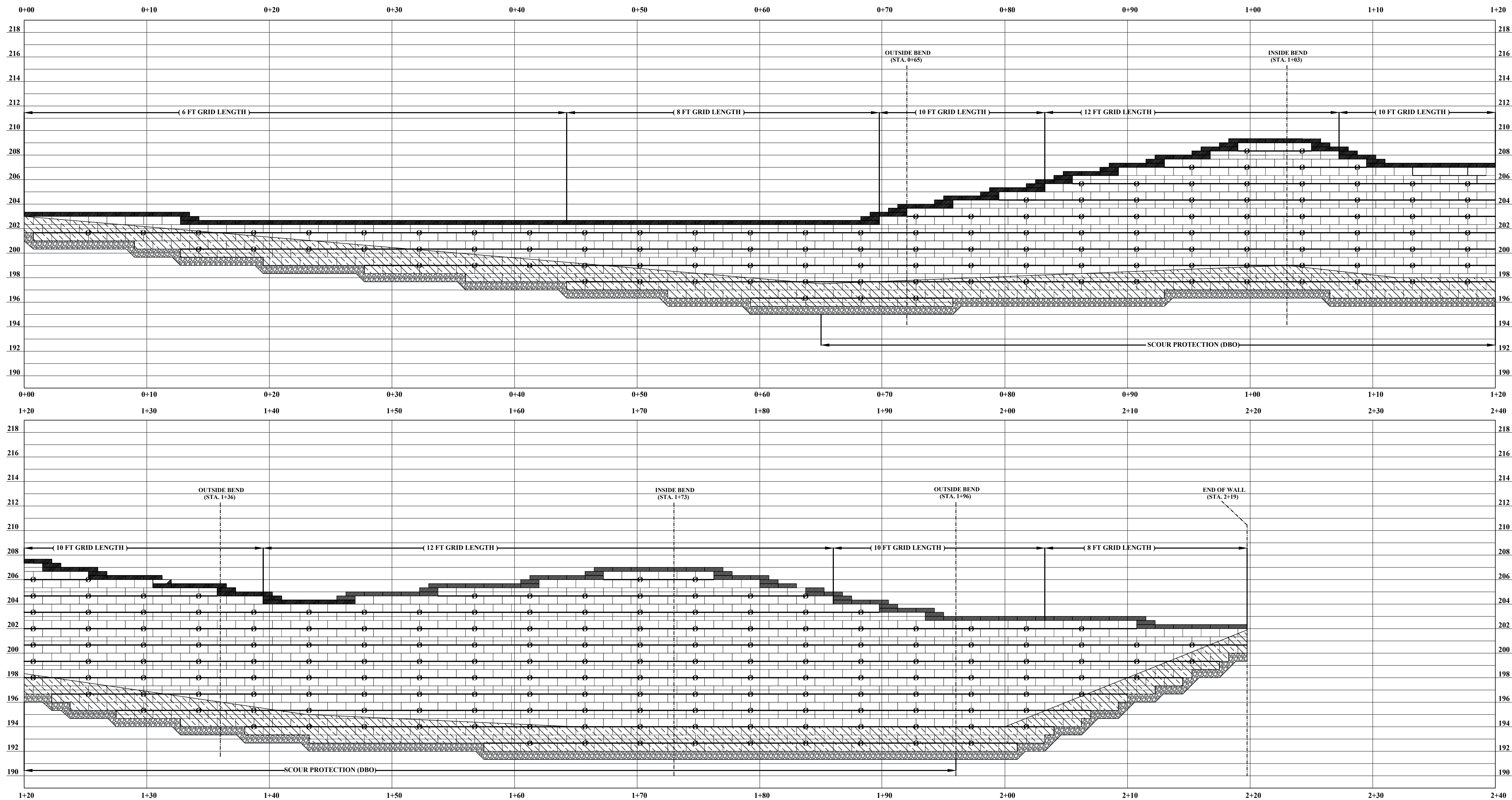

NOTE: RETAINING WALL #2 TO BE CONSTRUCTED WITH WASHED NO. 57 STONE WITHIN REINFORCED ZONE (STA. 0+65 THROUGH STA. 1+96).

RETAINING WALL #2

- LEGEND:
 1). STRATA SG-200 GEOGRID DESIGNATION
 2). EMBEDDED BLOCK DESIGNATION
 3). EMBEDDED BLOCK DESIGNATION
 4). LEVELING PAD DESIGNATION

TerraTech Engineers, Inc.

4905 Professional Court
 Raleigh, North Carolina 27609
 Phone: (919) 876-9799 Fax: (919) 876-8291



Providence Creek
 Angier, North Carolina
 Our Project Number 121-20-103521

REV	DATE	DESCRIPTION	BY
1	1-12-21	MSE OVER-HEADWALL ADDED	JRP

Retaining Wall #2 Profile

Designed by: Justin R. Pescosolido, P.E. Date: 12-16-20
 Drawn By: Justin R. Pescosolido, P.E. Date: 12-16-20
 Reviewed By: Christopher S. Pilz, P.E. Date: 12-16-20

SHEET
RW-4

Retaining Wall Design

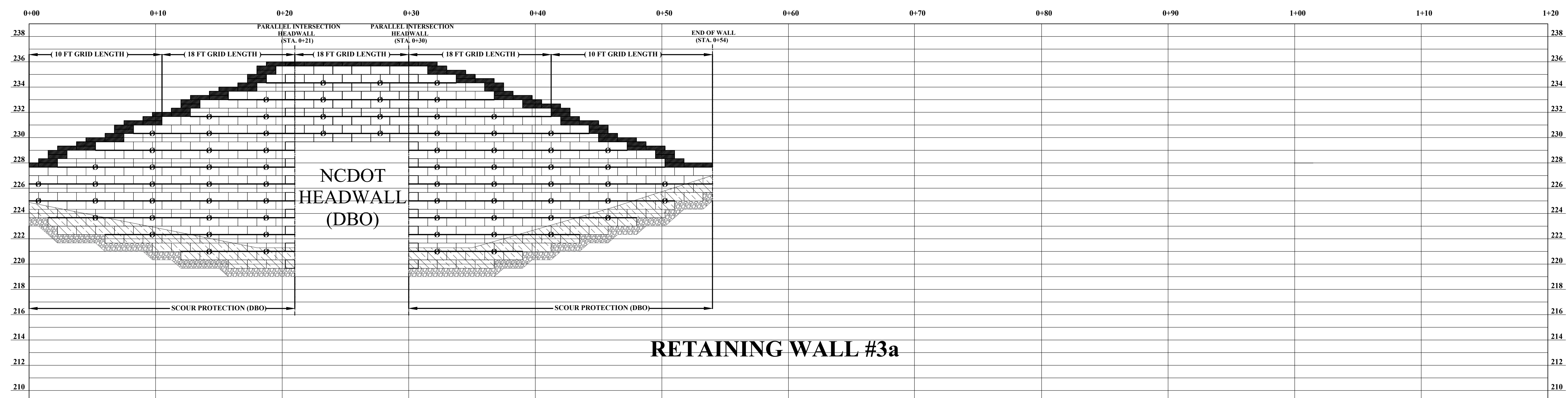

RETAINING WALL #3a

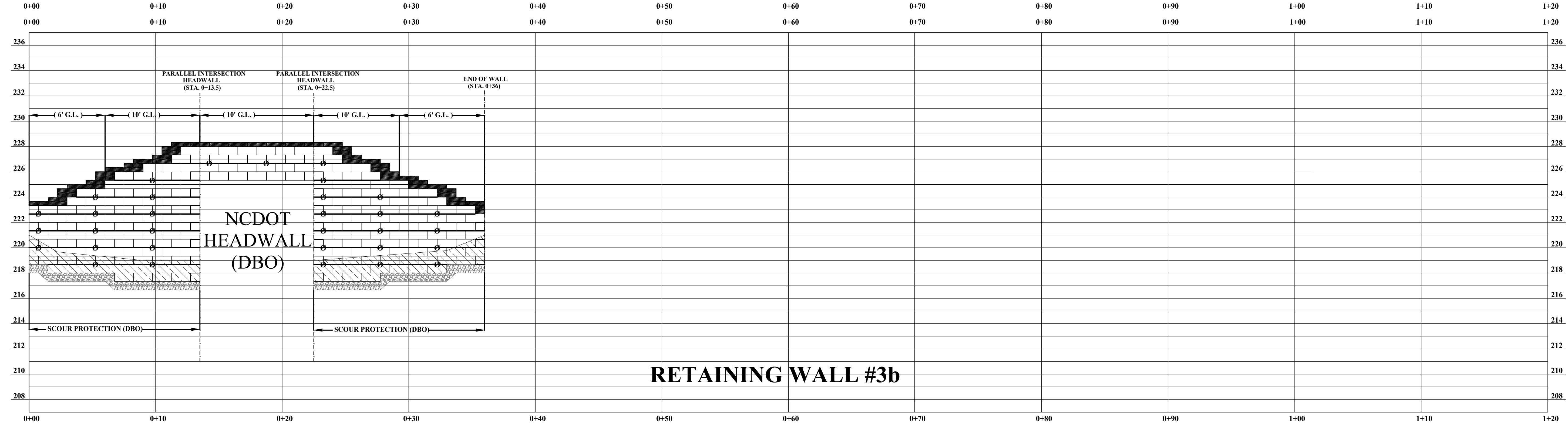

RETAINING WALL #3b

NOTE: RETAINING WALLS #3a AND #3b TO BE CONSTRUCTED WITH WASHED NO. 57 STONE WITHIN REINFORCED ZONE (ENTIRETY OF WALLS).

NOTE: ONE (1) #4 BAR @ 36" O.C. SHALL BE DRILLED AND EPOXIED (6" EMBEDDED, MIN) INTO THE TOP OF THE CONCRETE HEADWALL UTILIZING HILTI HIT-HY 200 (OR APPROVED EQUIVALENT). DOWEL SHALL EXTEND THROUGH ALL COURSES OF SEGMENTAL BLOCK WALL ABOVE. COURSES ENCLOSING DOWEL SHALL BE GROUTED SOLID.

- LEGEND:**
- 1). STRATA SG-200 GEOGRID DESIGNATION
 - 2). EMBEDDED BLOCK DESIGNATION
 - 3). LEVELING PAD DESIGNATION

TerraTech Engineers, Inc.

4905 Professional Court
Raleigh, North Carolina 27609
Phone: (919) 876-9799 Fax: (919) 876-8291

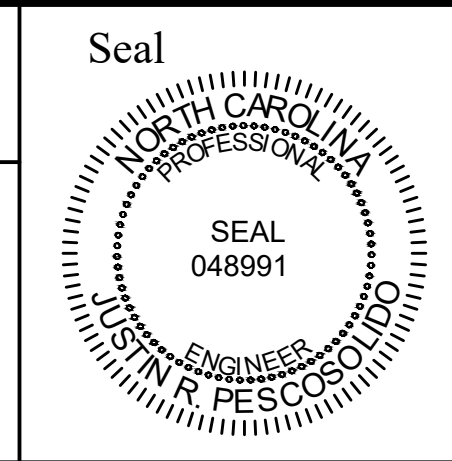

Providence Creek SD
Angier, North Carolina
Our Project Number 121-20-103521

REV	DATE	DESCRIPTION	BY
1	1-12-21	MSE OVER-HEADWALL ADDED	JRP

Retaining Wall #3a & #3b Profiles

Designed by: Justin R. Pescosolido, P.E.	Date: 12-16-20	SHEET RW-5
Drawn By: Justin R. Pescosolido, P.E.	Date: 12-16-20	
Reviewed By: Christopher S. Pilz, P.E.	Date: 12-16-20	
Retaining Wall Design		

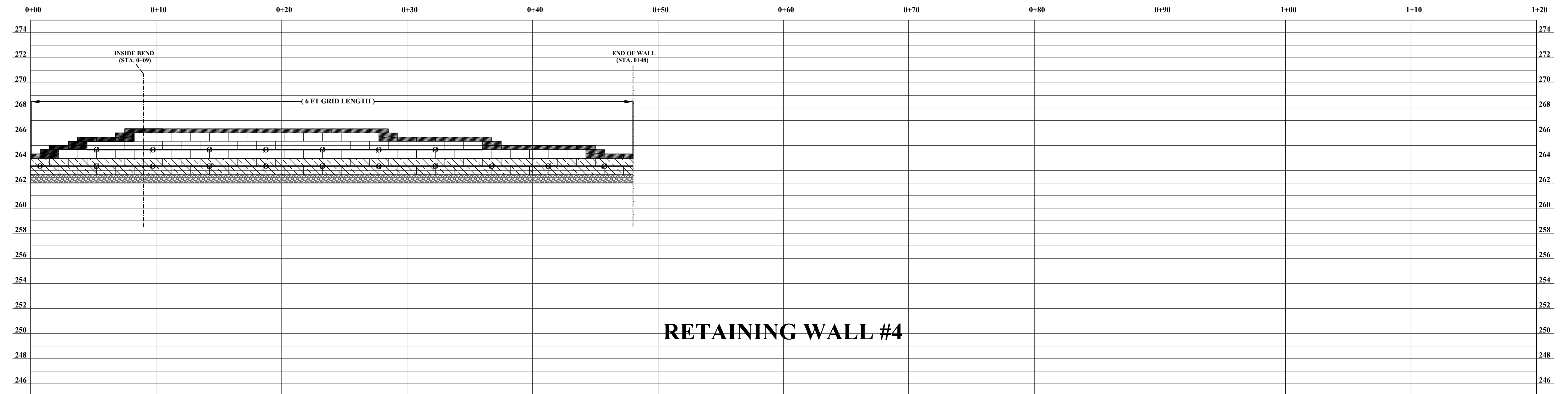

RETAINING WALL #4

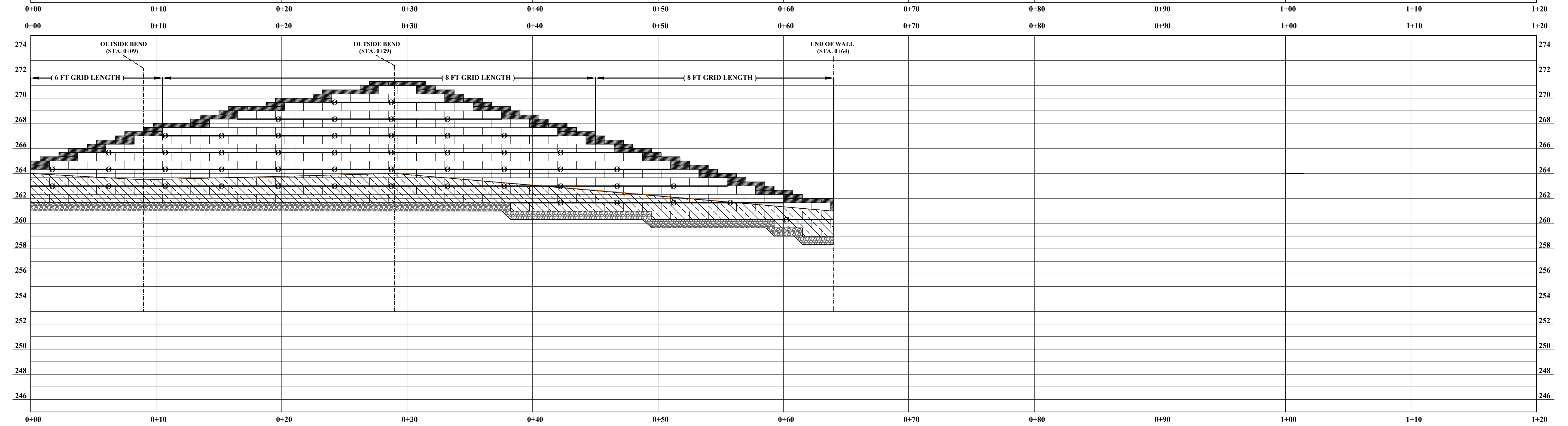

RETAINING WALL #5

- LEGEND:**
- 1). STRATA SG-200 GEOGRID DESIGNATION
 - 2). EMBEDDED BLOCK DESIGNATION
 - 3). LEVELING PAD DESIGNATION

TerraTech Engineers, Inc.

4905 Professional Court
 Raleigh, North Carolina 27609
 Phone: (919) 876-9799 Fax: (919) 876-8291



Providence Creek SD
 Angier, North Carolina
 Our Project Number 121-20-103521

REV	DATE	DESCRIPTION	BY
1	1-12-21	MSE OVER-HEADWALL ADDED	JRP

Retaining Wall #4 & #5 Profile

Designed by: Justin R. Pescosolido, P.E. Date: 12-16-20
 Drawn By: Justin R. Pescosolido, P.E. Date: 12-16-20
 Reviewed By: Christopher S. Pilz, P.E. Date: 12-16-20

SHEET
RW-6
Retaining Wall Design

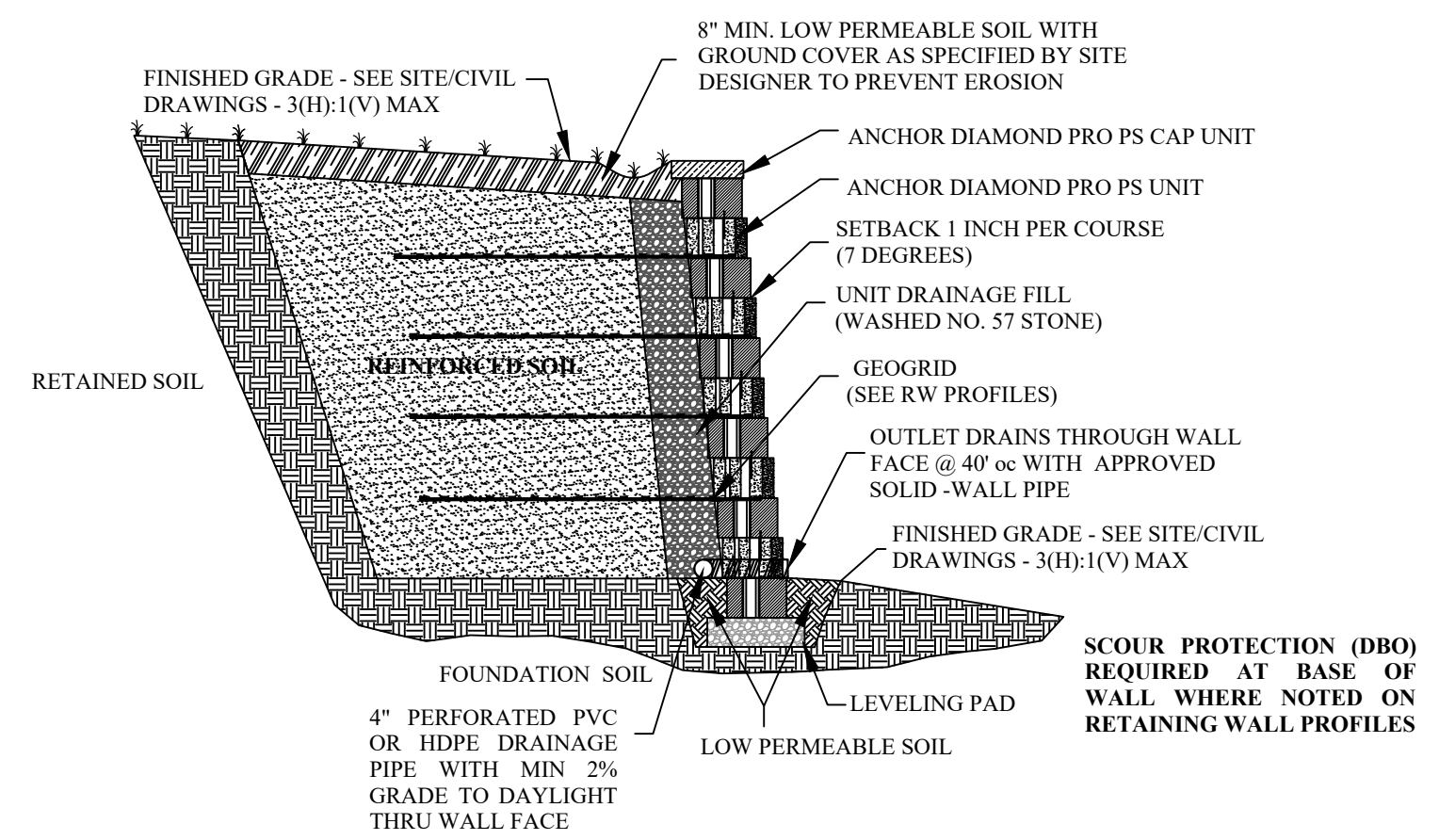

DIAMOND PRO PS RETAINING WALL DETAIL (SELECT FILL)

SCALE: NONE [Walls #2 (SEE PROFILE), #4, AND #5]

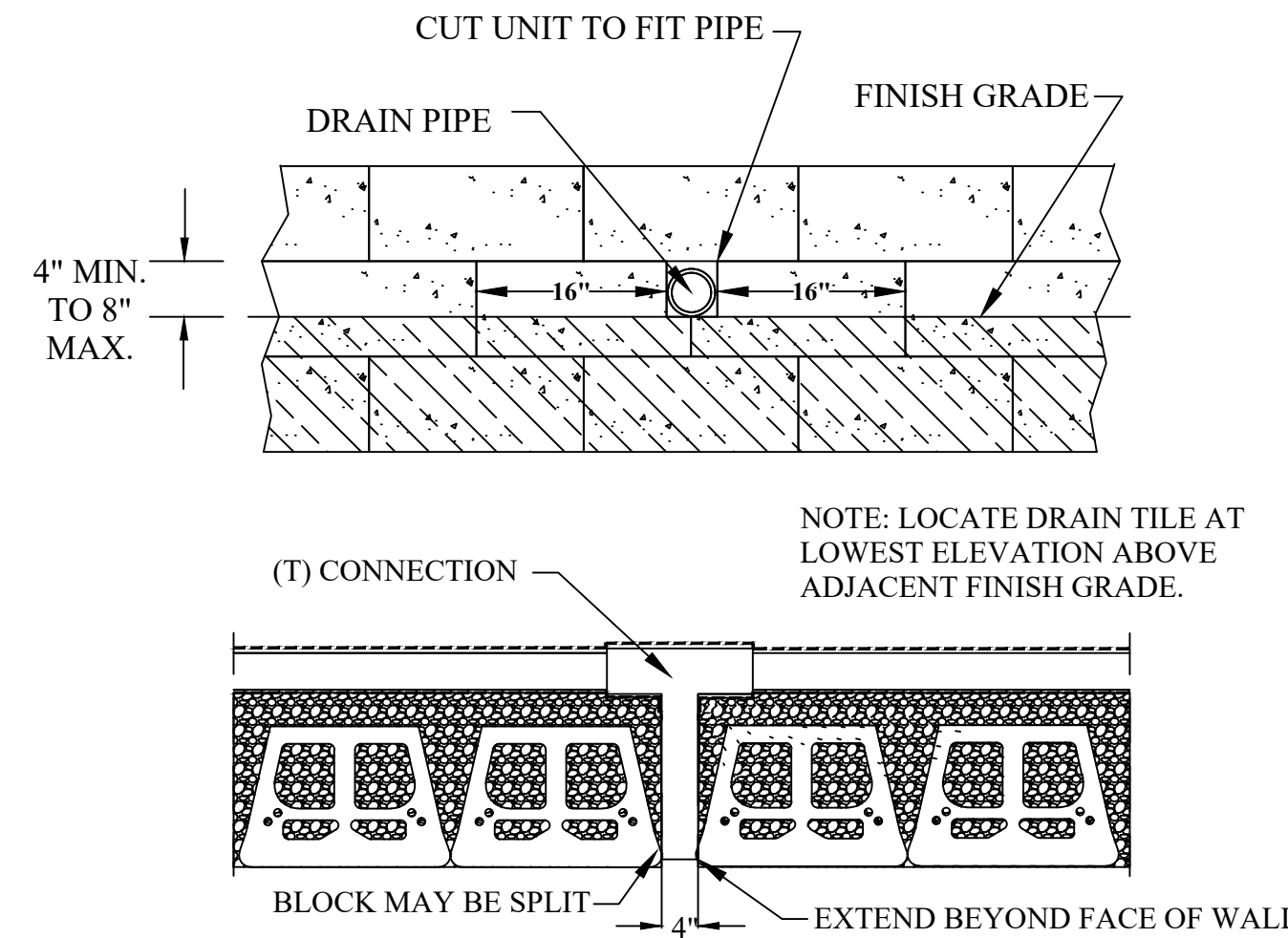

FACE OUTLET DRAIN DETAIL

SCALE: NONE

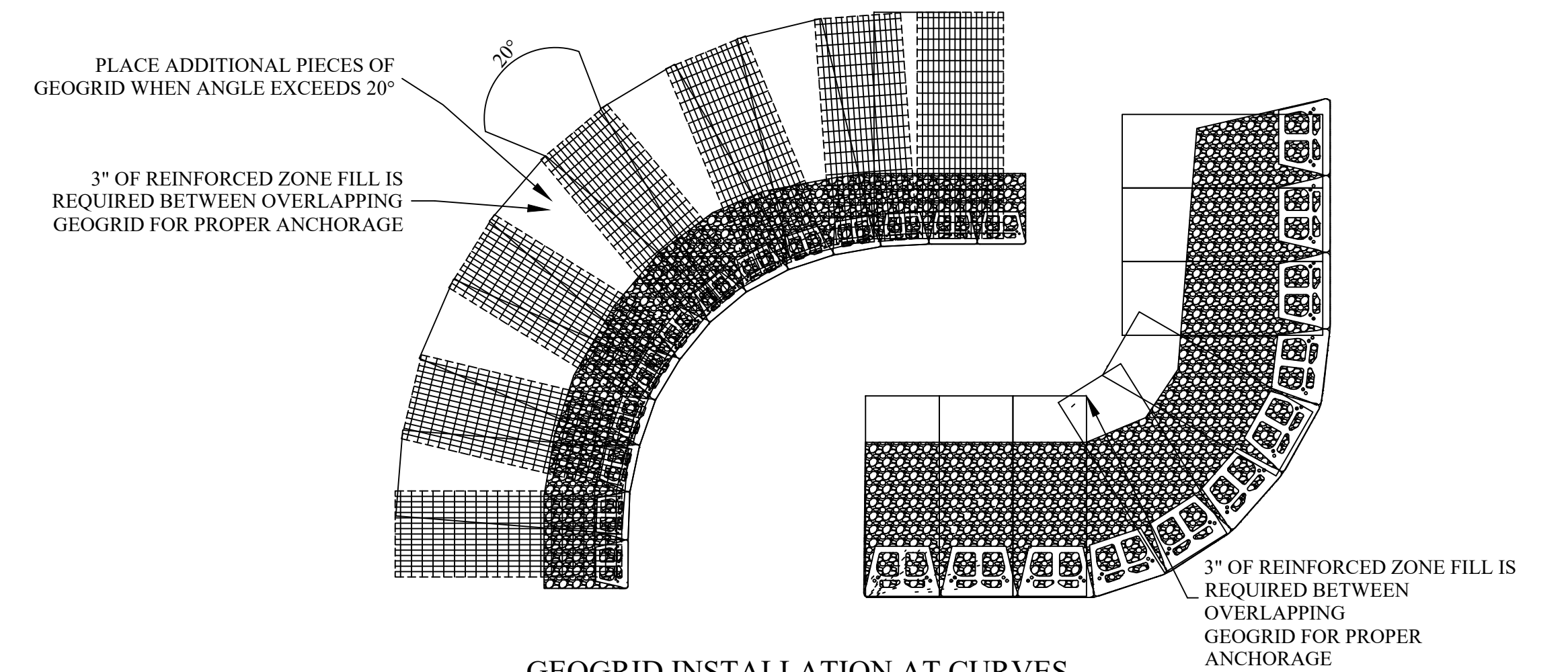

GEOGRID INSTALLATION AT CURVES

SCALE: NONE

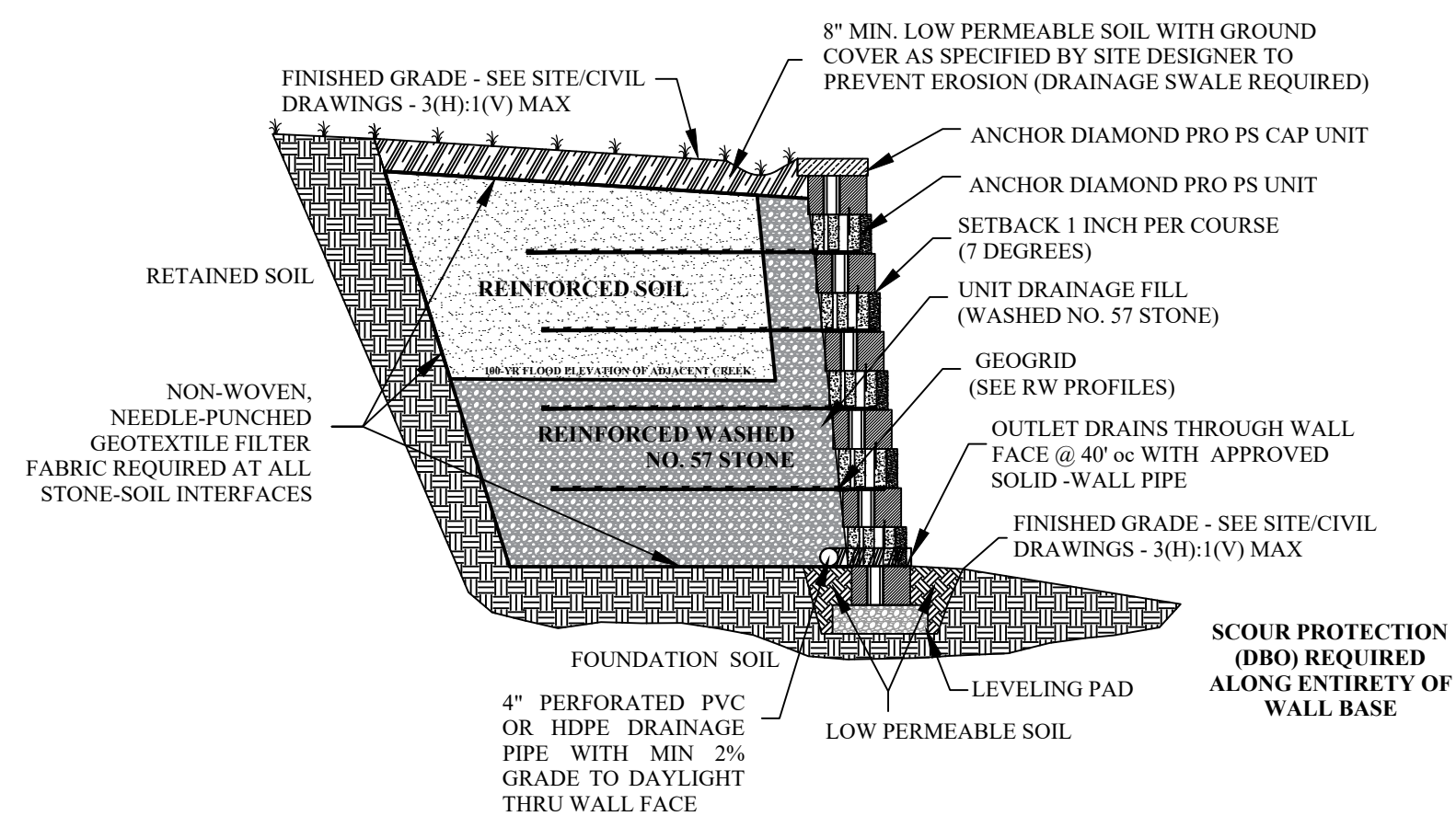

DIAMOND PRO PS RETAINING WALL DETAIL (WASHED 57 STONE)

SCALE: NONE [Walls #1a/1b, #2 (SEE PROFILE), and #3a/3b]

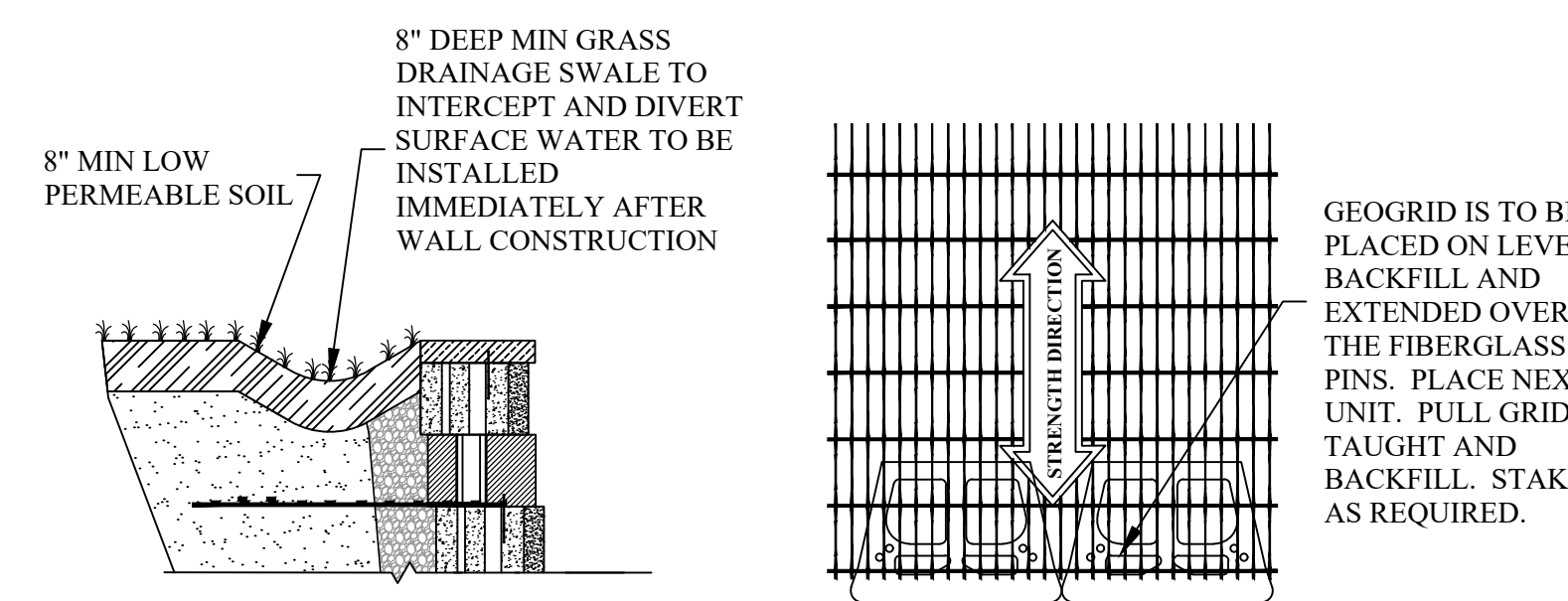

DRAINAGE SWALE DETAIL

SCALE: NONE

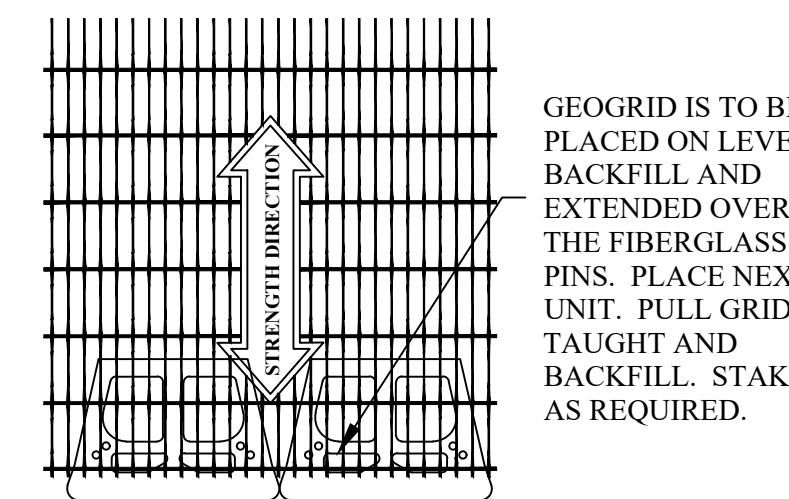

GRID AND PIN CONNECTION

SCALE: NONE

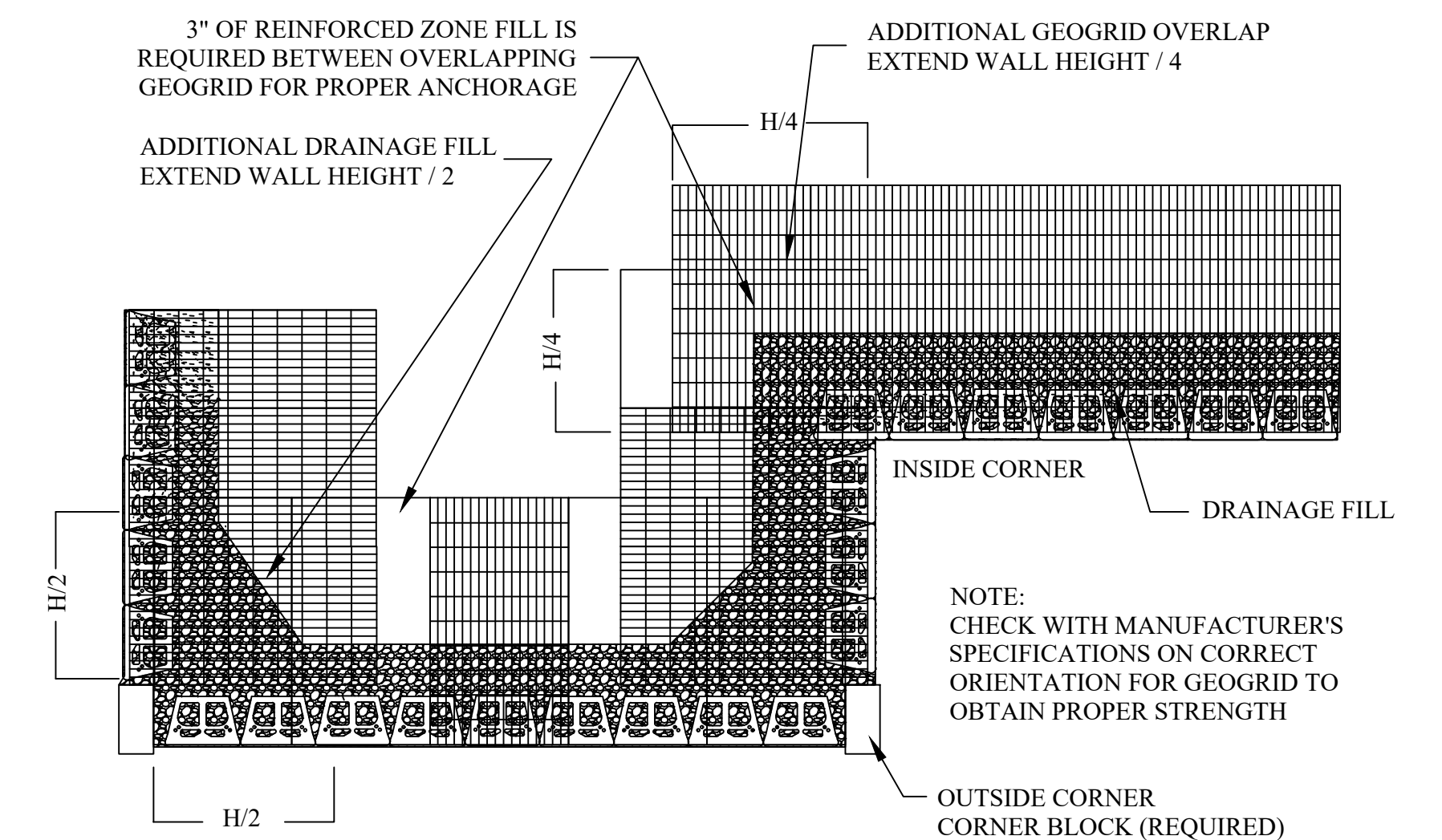

GEOGRID INSTALLATION AT CORNERS

SCALE: NONE

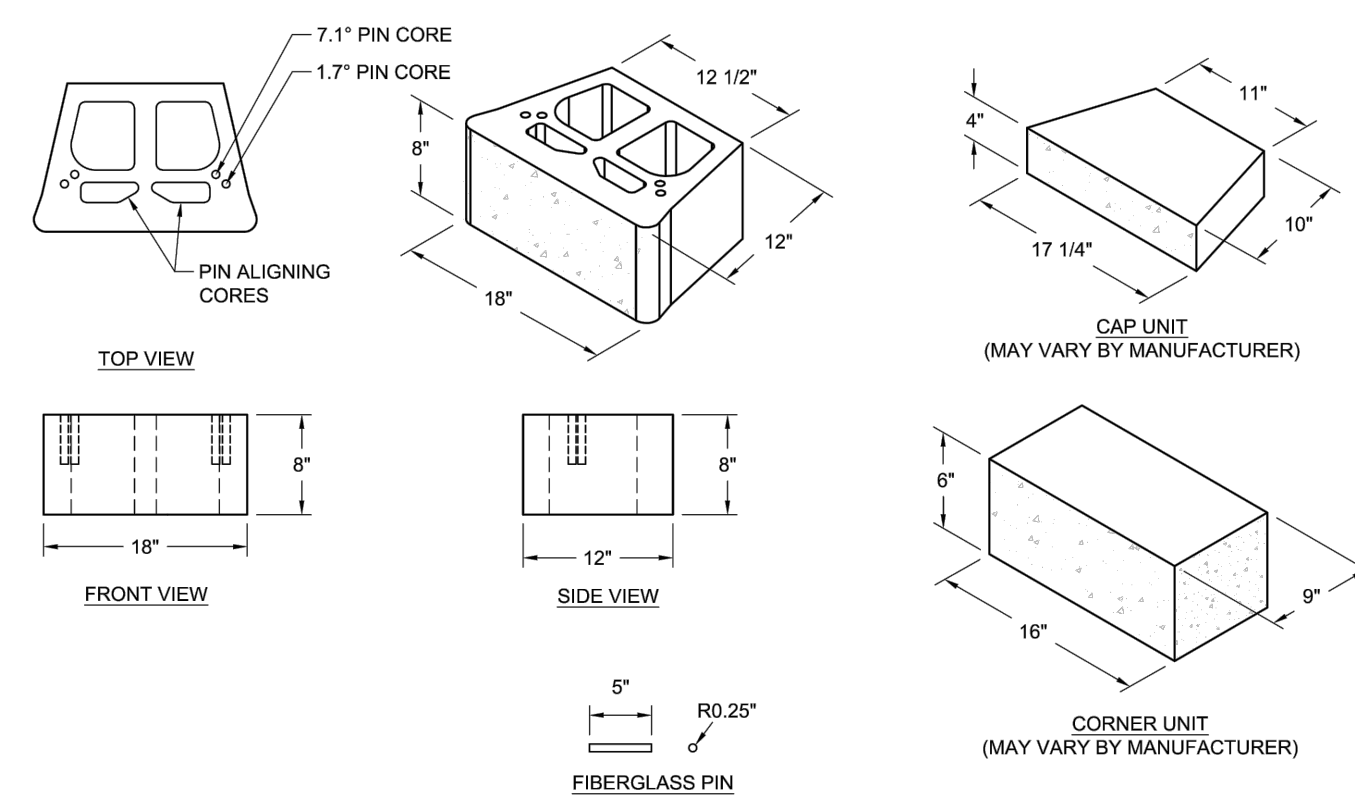

DIAMOND PRO UNIT DETAILS

SCALE: NONE

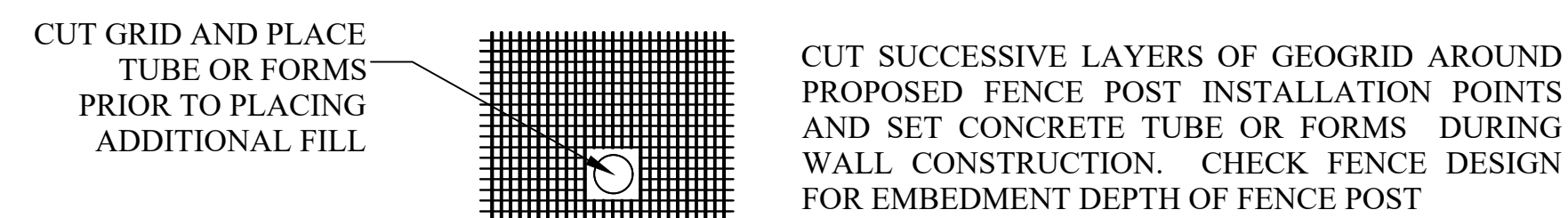
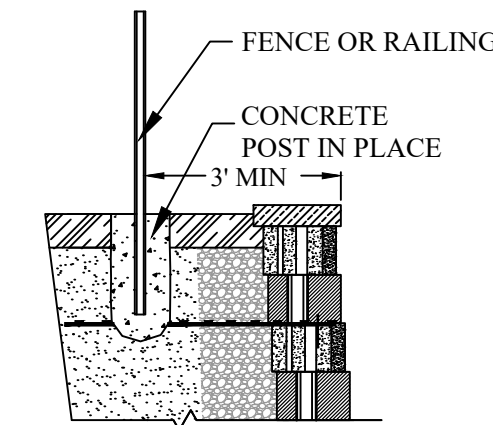

RAILING REQUIREMENTS FOR THE RETAINING WALL SHALL BE DETERMINED BY THE SITE DESIGNER. THE RAILING SHOULD BE DESIGNED IN ACCORDANCE WITH THE NORTH CAROLINA BUILDING CODE BY A REGISTERED DESIGN PROFESSIONAL. THE RAILING SHOULD BE DESIGNED SUCH THAT IT DOES NOT ADD ANY ADDITIONAL LATERAL FORCES TO THE RETAINING WALL. THE CONCRETE TUBES OR SLEEVE-IT FORMS FOR THE RAILINGS SHALL BE INSTALLED BY THE SITE CONTRACTOR AND COORDINATED WITH THE RETAINING WALL CONTRACTOR DURING CONSTRUCTION OF THE RETAINING WALL.

TYPICAL HAND RAILING DETAIL

SCALE: NONE

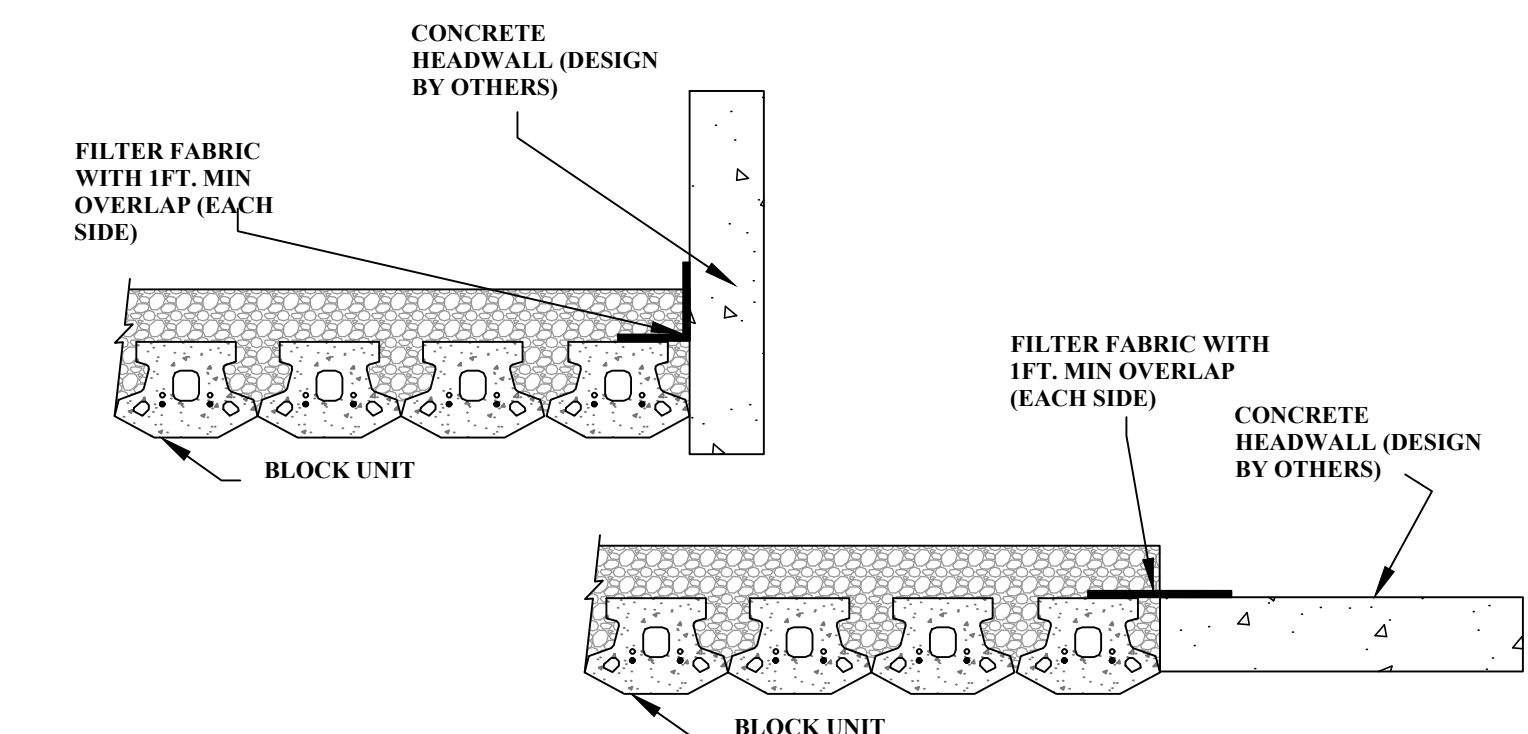

EXISTING FOUNDATION / WALL CONNECTION DETAIL

SCALE: NONE

TerraTech Engineers, Inc.

4905 Professional Court
Raleigh, North Carolina 27609
Phone: (919) 876-9799 Fax: (919) 876-8291

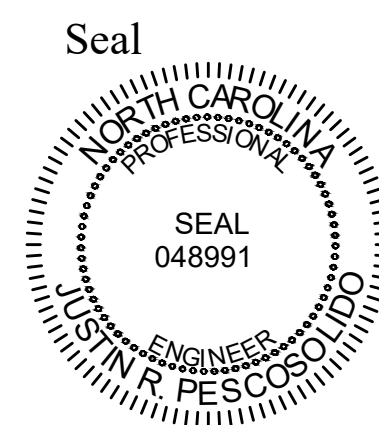

Providence Creek
Angier, North Carolina
Our Project Number 121-20-103521

REV	DATE	DESCRIPTION	BY
1	1-12-21	MSE OVER-HEADWALL ADDED	JRP

Diamond Pro PS Unit Details

Designed by: Justin R. Pescosolido, P.E.	Date: 12-16-20	SHEET RW-7
Drawn By: Justin R. Pescosolido, P.E.	Date: 12-16-20	
Reviewed By: Christopher S. Pilz, P.E.	Date: 12-16-20	
Retaining Wall Design		

1.0 GENERAL

SEGMENTAL RETAINING WALL SYSTEMS ARE DESIGNED AS GRAVITY RETAINING WALLS UTILIZING A HIGH DENSITY POLYESTER GEOGRID TO REINFORCE THE SOIL ZONE BEHIND THE WALL. THE GEOGRID IS POSITIVELY CONNECTED TO THE MODULAR CONCRETE BLOCKS CREATING A REINFORCED SOIL MASS CAPABLE OF RESISTING CERTAIN LATERAL EARTH PRESSURES AND CERTAIN SURCHARGED LOADS. ALL REFERENCES TO THE ENGINEER REFER TO TERRATECH ENGINEERS, INC.

1.1 QUALITY ASSURANCE

WORK SHALL BE PERFORMED ONLY BY AN EXPERIENCED CONTRACTOR. CONTRACTOR SHALL SUBMIT TO THE CERTIFYING ENGINEER EVIDENCE OF QUALIFICATIONS AND REFERENCES ON PROJECTS OF SIMILAR SCOPE. THE CERTIFYING ENGINEER RESERVES THE RIGHT TO REJECT ANY AND ALL QUALIFICATIONS SUBMITTALS. THE OWNER AND/OR GENERAL CONTRACTOR SHOULD PROVIDE AN INSPECTOR AS A FULL-TIME CONTINUOUS MONITOR OF WORK QUALITY.

1.2 BACK FILL MATERIALS

THE SOIL MATERIAL ASSOCIATED WITH THE RETAINING WALL(S) IN THE REINFORCED ZONE, THE RETAINED ZONE, AND THE FOUNDATION BEDDING SHALL HAVE, AT A MINIMUM, THE FOLLOWING PROPERTIES:

- A.) FOUNDATION SOILS ϕ = 28 DEGREES, COHESION = 0 PSF, WET UNIT WEIGHT = 115 LBS/CU.FT
- B.) RETAINED SOILS ϕ = 28 DEGREES, COHESION = 0 PSF, WET UNIT WEIGHT = 115 LBS/CU.FT
- C.) REINFORCED SOILS TYPE 1 ϕ = 30 DEGREES, COHESION = 0 PSF, WET UNIT WEIGHT = 120 LBS/CU.FT (PROCESSED FILL SOILS)
- D.) REINFORCED SOILS TYPE 1 ϕ = 34 DEGREES, COHESION = 0 PSF, WET UNIT WEIGHT = 110 LBS/CU.FT (WASHED NO. 57 STONE)

THESE SOIL PROPERTIES ARE BASED ON OUR PREVIOUS EXPERIENCE WITH SIMILAR CONSTRUCTION IN CLOSE GEOGRAPHIC VICINITY TO THE SITE AND OUR REVIEW OF AVAILABLE SOIL SURVEY MAPS. THE PROPERTIES ARE PROVIDED UNDER THE ASSUMPTION THAT ALL ENCOUNTERED SOFT, WET SOILS WILL BE REMOVED AND REPLACED PRIOR TO CONSTRUCTION. IF THE ASSUMED VALUES DO NOT REPRESENT THE ACTUAL SOIL CONDITIONS, THE ENGINEER SHALL BE NOTIFIED FOR REVIEW AND POSSIBLE REDESIGN.

1.3 FOUNDATION LOADS

THE MAXIMUM APPLIED FOUNDATION LOAD FOR THE WALL(S) IS: **2.0 KIPS/SQ.FT.**

1.4 WALL BATTER

WALL BATTER SHALL BE MAINTAINED PER MANUFACTURER'S SPECIFICATIONS (MINIMUM 1 INCH PER COURSE; 7 DEGREES).

2.0 MATERIAL NOTES

2.1 CONCRETE MASONRY WALL UNITS

CONCRETE WALL UNITS SHALL BE ANCHOR DIAMOND PRO PS BLOCK UNITS, MANUFACTURED IN ACCORDANCE WITH ASTM C-1372 AND ASTM C-140, AND SHALL HAVE A MINIMUM 28-DAY COMPRESSIVE STRENGTH OF 3,000 PSI.

2.2 RETAINING WALL SHEAR CONNECTIONS

SEGMENTAL WALL UNITS SHALL BE INTERLOCKED UTILIZING MANUFACTURER RECOMMENDED SHEAR PINS.

2.3 GEOGRID REINFORCEMENT

GEOSYNTHETIC REINFORCEMENT SHALL CONSIST OF HIGH TENACITY GEOGRIDS MANUFACTURED FOR SOIL REINFORCEMENT APPLICATIONS. THE TYPE, LENGTH, AND PLACEMENT OF THE REINFORCING GEOSYNTHETIC SHALL BE AS SHOWN ON THE PLANS. STRATAGRID SG-200 IS UTILIZED IN THIS RETAINING WALL DESIGN.

2.4 GEOTEXTILE FILTER FABRIC

GEOTEXTILE FILTER FABRIC SHALL CONSIST OF NEEDLE PUNCHED NON-WOVEN POLYPROPYLENE MATERIAL WHICH MEETS THE AASHTO M288-2006 CLASS 3 STRENGTH CRITERIA. IT SHALL HAVE A MAXIMUM AVERAGE ROLL VALUE OF 0.25 MM FOR ITS APPARENT OPENING SIZE AND PERMITIVITY OF AT LEAST 0.2/SEC. PRE-APPROVED NON-WOVEN GEOTEXTILES INCLUDE AMOCO 4546, CARTHAGE MILLS FX-40HS, SYNTHETIC INDUSTRIES GEOTEX 401, AND TENCATE MIRAFI 140N.

2.5 LEVELING PAD

MATERIAL SHALL CONSIST OF COMPACTED AGGREGATE BASE COURSE (ABC) STONE, WASHED NO. 57 STONE, OR UNREINFORCED CONCRETE. THE PAD SHALL BE A MINIMUM OF 8" THICK (UNO). THE ABC STONE SHALL BE COMPACTED TO 95% OF THE STANDARD PROCTOR (ASTM D-698) MAXIMUM DRY DENSITY. AGGREGATE MATERIAL SHALL RECEIVE A MINIMUM OF ONE PASS OF THE COMPACTION EQUIPMENT. THE TOP OF THE LEVELING PAD FOR THE WALL SECTIONS SHALL BE MAINTAINED IN ACCORDANCE WITH THE PROVIDED WALL PROFILES.

2.6 SOIL PROPERTIES

REINFORCED ZONE TYPE 1 FILL MATERIALS SHALL CLASSIFY AS GM, GP, SP, SP-SM, SM OR SC WITH NO MORE THAN 20% FINES. THE MINIMUM INTERNAL ANGLE OF FRICTION, COHESION, AND WET UNIT WEIGHT SHALL BE EQUAL TO OR GREATER THAN THE DESIGN VALUES PROVIDED IN SECTION 1.2. REINFORCED ZONE TYPE 2 FILL SOILS SHALL CONSIST OF WASHED NO. 57 STONE.

2.7 UNSUITABLE MATERIAL

SOILS CONTAINING ROOTS, BRUSH, SOD, OR OTHER ORGANIC MATERIAL SHALL NOT BE PERMITTED AS FILL. FROZEN SOILS, SNOW, ICE, HEAVY CLAYS, OR WET SOILS SHALL NOT BE PERMITTED AS FILL. MATERIAL PASSING THE NO. 40 SIEVE SHALL NOT HAVE A LIQUID LIMIT OF GREATER THAN 40 AND A PLASTICITY INDEX OF GREATER THAN 15, UNLESS WRITTEN CONSENT IS OBTAINED FROM THE DESIGN ENGINEER PRIOR TO PLACEMENT.

3.0 INSTALLATION NOTES

3.1 FOUNDATION REQUIREMENTS

THE FOUNDATION BEARING CAPACITY THAT WAS ASSUMED FOR THE DESIGN SHALL BE VERIFIED IN THE FIELD, AND COPIES OF THE TESTS PROVIDED TO THE CERTIFYING ENGINEER. THE FOUNDATION ZONE SHALL BE CLEARED OF ALL DEBRIS AND LOOSE SOIL. FOUNDATION SOILS NOT MEETING THE MINIMUM DESIGN CRITERIA, SHALL BE REMOVED AND REPLACED UTILIZING AGGREGATE BASE COURSE (ABC) STONE, PLACED IN LIFTS NOT EXCEEDING 8", AND COMPACTED TO AT LEAST 95% OF THE STANDARD PROCTOR (ASTM D-698) MAXIMUM DRY DENSITY. ALTERNATIVELY, CONSOLIDATED WASHED NO. 57 STONE (MAX. 8 INCH LOOSE LIFTS), WRAPPED IN AN APPROVED GEOTEXTILE FILTER FABRIC MAY BE UTILIZED IF GROUNDWATER IS PRESENT OR EXPECTED TO BE PRESENT IN THE REMEDIATION AREAS. REMEDIATION EXCAVATIONS SHALL BE DE-WATERED PRIOR TO MATERIAL REPLACEMENT. SOIL REMEDIATION EFFORTS SHALL BE PERFORMED UNDER THE RESPONSIBLE CHARGE OF A NORTH CAROLINA LICENSED PROFESSIONAL ENGINEER.

3.2 FIRST BLOCK COURSE

THE FIRST COURSE OF BLOCK SHALL BE PLACED ON TOP OF AND IN FULL CONTACT WITH THE LEVELING PAD. THE UNITS SHALL MAINTAIN A MINIMUM DISTANCE OF 6" FROM THE FRONT AND BACK OF THE LEVELING PAD. PROPER ALIGNMENT MAY BE ACHIEVED WITH THE AID OF A STRING LINE. PROCEED TO THE NEXT COURSE OF BLOCK. EACH UNIT SHALL BE IN CONTACT WITH THE UNITS ON BOTH SIDES AS WELL AS ABOVE AND BELOW. SOME ADJUSTMENTS MAY BE REQUIRED FOR WALLS WITH CURVES AND A BATTER.

3.3 GEOGRID INSTALLATION

THE GEOGRID REINFORCEMENT SHALL BE LAID HORIZONTALLY ON COMPACTED BACKFILL AND CONNECTED TO THE CONCRETE WALL UNITS IN ACCORDANCE WITH THE MANUFACTURER'S SPECIFICATIONS. GEOGRID SHALL BE PULLED TAUT REMOVING ALL SLACK FROM THE MATERIAL AND ANCHORED BEFORE ADDING FILL. GEOGRID SHALL BE INSTALLED AT THE ELEVATIONS AND LENGTHS REQUIRED AS SHOWN ON THE PLANS. THE SOIL SURFACE SHALL BE SMOOTH AND LEVEL AND HAVE BEEN COMPACTED BEFORE INSTALLING THE GEOGRID.

3.4 REINFORCED ZONE FILL PLACEMENT

REINFORCED ZONE TYPE 1 FILL MATERIALS SHALL BE PLACED IN A MAXIMUM 6" LIFT THAT IS COMPACTED TO 95% OF THE STANDARD PROCTOR (ASTM D-698) MAXIMUM DRY DENSITY AT A MOISTURE CONTENT WITHIN 3% OF THE OPTIMUM MOISTURE CONTENT. REINFORCED ZONE TYPE 2 FILL MATERIALS SHALL BE PLACED IN MAXIMUM 8" LIFTS AND CONSOLIDATED WITH AT LEAST 2 PASSES OF APPROPRIATE COMPACTION EQUIPMENT. ONLY HAND OPERATED EQUIPMENT SHALL BE ALLOWED WITHIN 3 FEET OF THE SEGMENTAL UNITS. FILL SHALL BE PLACED FROM THE WALL REARWARD TO INSURE TAUTNESS OF THE GEOGRID. CONSTRUCTION EQUIPMENT SHALL NOT BE OPERATED DIRECTLY ON THE GEOGRID.

3.5 RETAINING WALL CAPS

APPLY A CONSTRUCTION ADHESIVE TO THE UNITS TO PREVENT THEIR REMOVAL.

3.6 SOIL TESTING

WHERE REINFORCED ZONE TYPE 1 MATERIALS ARE PLACED, COMPACTION TESTING SHALL BE PERFORMED FOR EVERY LIFT ELEVATION REQUIRING GEOGRID OR EVERY THIRD LIFT AS A MINIMUM. TEST RESULTS SHALL BE PROVIDED TO THE CERTIFYING ENGINEER.

4.0 HYDROSTATIC PRESSURE POTENTIAL

THE ENGINEER SHALL BE NOTIFIED IF ANY OF THE FOLLOWING SHOULD BECOME EVIDENT:

- WATER OR WETNESS FROM OR IN A CUT BANK
- LOCAL SPRINGS, LOCAL STORM DRAINS, SEWER, OR WATER LINES UNDER OR BEHIND THE WALL(S).

5.0 ACCEPTABLE BLOCK

SEGMENTAL BLOCK UNITS SHALL BE USED AND KEPT FREE OF DEFECTS THAT WOULD INTERFERE WITH THE PLACING OR POSITIONING OF THE UNIT OR IMPAIR ITS STRENGTH. THE CONTRACTOR SHALL PREVENT EXCESS MUD, WET CEMENT, EPOXY, AND THE LIKE MATERIALS FROM COMING IN CONTACT WITH AND AFFIXING TO THE UNITS. MINOR CRACKS INCIDENTAL TO THE USUAL METHOD MANUFACTURING OR MINOR CHIPPING RESULTING FROM SHIPMENT AND DELIVERY ARE NOT GROUNDS FOR REJECTION.

6.0 ACCEPTABLE GEOGRID

GEOGRID SHALL BE REJECTED IF 20% OR MORE OF THE STRUCTURAL RIBS HAVE BEEN CUT OR RIPPED. THE CONTRACTOR SHALL INSPECT ALL GEOGRID DELIVERED TO THE SITE AND REJECT MATERIALS THAT MEET THIS CRITERIA. THE CONTRACTOR SHALL PREVENT EXCESS MUD, WET CEMENT, EPOXY, AND LIKE MATERIALS FROM COMING IN CONTACT WITH AND AFFIXING TO THE GEOGRID MATERIAL. IF THE GEOGRID IS DAMAGED ONSITE, IT SHALL BE REPLACED AT THE CONTRACTOR'S EXPENSE.

7.0 DRAINAGE COMPOSITE

DRAINAGE COMPOSITE REQUIREMENTS TO BE DETERMINED BY PROJECT GEOTECHNICAL ENGINEER AT TIME OF CONSTRUCTION.

8.0 SPECIAL PROVISIONS

- A.) CONSTRUCTION OF THE RETAINING WALL SHALL NOT UNDERMINE ANY EXISTING CONSTRUCTION. THE ENGINEER SHALL BE NOTIFIED IMMEDIATELY IF THE EXCAVATION FOR THE WALL IS EXPECTED TO EXTEND BEYOND THE PROPERTY BOUNDARY OR UNDERMINE ANY EXISTING CONSTRUCTION. SIMILARLY, ANY SUBSEQUENT CONSTRUCTION SHALL BE CARRIED OUT SO AS TO AVOID UNDERMINING OR DAMAGING ANY PORTIONS OF THESE RETAINING WALLS.
- B.) **WE NOTE THAT SCOUR PROTECTION (DBO) IS REQUIRED ALONG THE BASE OF RETAINING WALLS #1a, #1b, #3a, #3b, AND PORTIONS OF WALL #2. SCOUR PROTECTION SHALL BE DESIGNED BY SITE/CIVIL ENGINEER OF RECORD. WE HAVE NOT PERFORMED A SCOUR STUDY OR DESIGN OF ANY ENVIRONMENTAL OR HYDROLOGIC COMPONENTS RELATED TO THESE RETAINING WALLS AND/OR ADJACENT SITE CONDITIONS.**
- C.) MAINTAIN THE DIRECTION OF DRAINAGE AWAY FROM THE FACE AT ALL TIMES DURING CONSTRUCTION OF THE RETAINING WALL AND AFTER FINISHED GRADING. DOWNSPOUTS AND FOUNDATION DRAINS SHALL BE DIRECTED TO DISCHARGE AWAY FROM THE TOPS OF ANY RETAINING WALL AND SHALL NOT BE DIRECTED TO DISCHARGE DIRECTLY UP-GRADIENT OF ANY RETAINING WALL.
- D.) THE ENGINEER SHALL BE NOTIFIED BY THE INSTALLING CONTRACTOR SHOULD THE EMBEDMENT DEPTH OF THE RETAINING WALL BE LESS THAN THAT WHICH IS SHOWN ON THE RETAINING WALL PROFILES OF THIS DESIGN. CONSIDERATION SHOULD BE GIVEN TO INCLUDING PROVISIONS IN THE HOME OWNERS RESTRICTIVE COVENANTS TO PREVENT HOME OWNERS FROM INSTALLING STRUCTURES OR POST-CONSTRUCTION DRAINAGE SYSTEMS NEAR THESE RETAINING WALLS WITHOUT PRIOR APPROVAL OF A NORTH CAROLINA LICENSED PROFESSIONAL ENGINEER AND THE WALL DESIGNER.
- E.) AS PER THE NORTH CAROLINA STATE BUILDING CODE, A BUILDING PERMIT MUST BE OBTAINED PRIOR TO WALL CONSTRUCTION. THE CONTRACTOR SHALL CONTACT THE LOCAL MUNICIPALITY CODE ENFORCEMENT DIVISION TO OBTAIN A BUILDING PERMIT.

9.0 QUALIFICATION OF DESIGN

- A.) STABILITY OF ANY TEMPORARY SLOPES REQUIRED BY THE INSTALLATION OF A SEGMENTAL RETAINING WALL SHALL BE ADDRESSED BY A QUALIFIED GEOTECHNICAL ENGINEER. RESPONSIBILITY OF THESE TEMPORARY SLOPES RESTS WITH THE OWNER AND/OR THE CONTRACTOR OF THE PROJECT AND THE SLOPES SHALL MEET ALL OSHA STANDARDS.
- B.) HANDRAIL/GUARDRAIL REQUIREMENTS SHALL BE DETERMINED BY THE ARCHITECT OR SITE CIVIL DESIGNER. IF ADJUSTMENTS TO THE WALL LOCATION ARE REQUIRED TO ALLOW INSTALLATION OF THE HANDRAIL/GUARDRAIL, THE RETAINING WALL DESIGN ENGINEER SHOULD BE NOTIFIED IMMEDIATELY.
- C.) NOTIFY THE DESIGN ENGINEER PRIOR TO MODIFYING WALL CONSTRUCTION OR IF EXISTING SITE CONDITIONS DEVIATE FROM CONDITIONS PRESENTED IN THIS RETAINING WALL DESIGN.

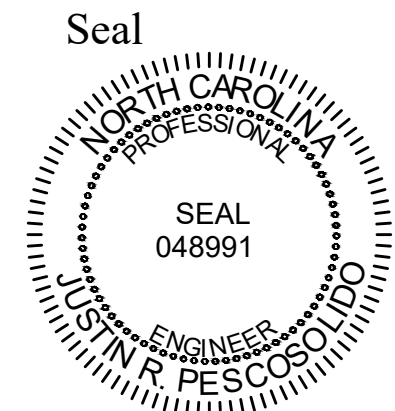
<h1 style="margin: 0;">TerraTech Engineers, Inc.</h1> <p style="margin: 0;">4905 Professional Court Raleigh, North Carolina 27609 Phone: (919) 876-9799 Fax: (919) 876-8291</p>		<p style="margin: 0;">Providence Creek Angier, North Carolina Our Project Number 121-20-103521</p>	REV	DATE	DESCRIPTION	BY	<h2 style="margin: 0;">Retaining Wall Specifications</h2>
			1	1-12-21	MSE OVER-HEADWALL ADDED	JRP	
							SHEET
							Designed by: Justin R. Pescosolido, P.E. Date: 12-16-20
							Drawn By: Justin R. Pescosolido, P.E. Date: 12-16-20
							Reviewed By: Christopher S. Pilz, P.E. Date: 12-16-20
Retaining Wall Design							RW-8