

- SHINGLES AS SPEC'D
- DECORATIVE GABLE BRACKET
- BOARD & BATTEN SIDING AS SPEC'D
- 10" BAND
- 8" HEADER TRIM W/ CROWN CAP OPTIONAL
- 4" TRIM
- B&B SHUTTERS AS SPEC'D
- STONE FOUNDATION AS SPEC'D



**FRONT ELEVATION**  
 SCALE: ..... 1/4" = 1'-0"

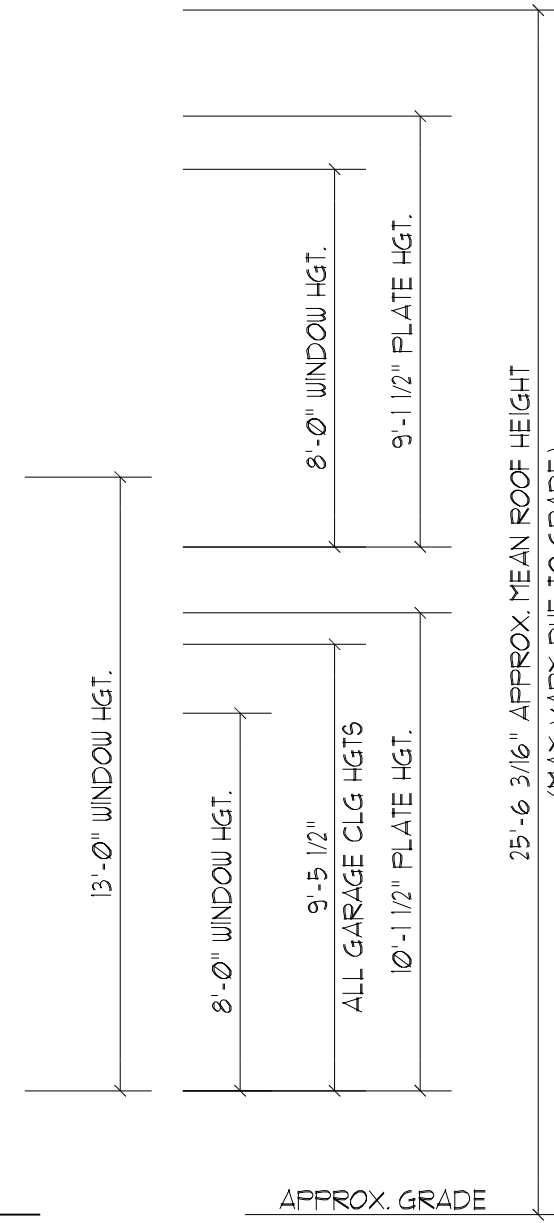

TABLE 402.1 ENERGY CONSERVATION CODE INSULATION AND FENESTRATION REQUIREMENTS BY COMPONENT

CLIMATE ZONE	FENS. U-FACT	SKY-LIGHT U-FACT	GLAZED FENS. SHGC	MINIMUM INSULATION R-VALUE						
				CEILING	WOOD WALL	MAS. WALL	FLOOR	BSPNT. WALL	SLAB DEPTH	GRAILL SPACE
3	0.35	0.55	0.30	30 or 30 cont.	15 or 13-2.5	5/13 or 5/10 cont.	19	5/13	0	5/13
4	0.35	0.55	0.30	30 or 30 cont.	15 or 13-2.5	5/13 or 5/10 cont.	19	10/13	10	10/13
5	0.35	0.55	NR	30 or 30 cont.	19, 13-5 or 15-5	13/11 or 13/12.5 cont.	30	10/13	10	10/13

SEE TABLE 301 CLIMATE ZONES BY COUNTY ENERGY CONSERVATION CODE  
 SEE FOOTNOTES OF TABLE N1021 FOR FOOTNOTES AND DETAILED EXPLANATIONS.



**LEFT SIDE ELEVATION**  
 SCALE: ..... 1/4" = 1'-0"

David D Grurd  
 (919) 601-1406  
 DynamicDesignGroup@gmail.com  
 www.DynamicDesignGroupInc.com

The drawings and specifications (plans) contained on these pages are the property of Dynamic Design Group and are offered to the named client or contractor for a conditional one time use. The conditional use is limited to the lot and subdivision specified herein, and only for said location. COPYRIGHT 2024  
 Contractor shall verify all conditions and dimensions prior to construction. Any error or omissions shall be reported to Dynamic Design Group for corrections or justification. Once construction has commenced, the contractor shall assume all responsibility. Dimensions govern over scale, code governs over dimensions.

**KEN HARVEY**  
 PROJECT FOR: HOMES  
 LOCATION: FUQUAY VARINA, NC  
 LOT: 51  
 SUBDIVISION: COTTON FARMS  
 COUNTY: WAKE

**LAVORE**  
 PLAN NAME  
**A1-3283-81GR**  
 PLAN I.D.  
**5.8.24**  
 DATE



**REAR ELEVATION**  
 SCALE: ..... 1/4" = 1'-0"



**RIGHT SIDE ELEVATION**  
 SCALE: ..... 1/4" = 1'-0"

David D Grorud  
 (919) 601-1406  
 DynamicDesignGroup@gmail.com  
 www.DynamicDesignGroupInc.com

The drawings and specifications (plans) contained on these pages are the property of Dynamic Design Group and are offered to the named client or contractor for a conditional one time use. The conditional use is limited to the lot and subdivision specified herein, and only for said location. COPYRIGHT 2024

Contractor shall verify all conditions and dimensions prior to construction. Any error or omissions shall be reported to Dynamic Design Group for corrections or justification. Once construction has commenced, the contractor shall assume all responsibility. Dimensions govern over scale, code governs over dimensions.

KEN HARVEY  
 PROJECT FOR: HOMES  
 LOCATION: FUQUAY VARINA, NC  
 LOT: 51  
 SUBDIVISION: COTTON FARMS  
 COUNTY: WAKE

**LAVORE**

PLAN NAME

A1-3283-81GR

PLAN I.D.

5.8.24

DATE

**A-1B**

SHEET

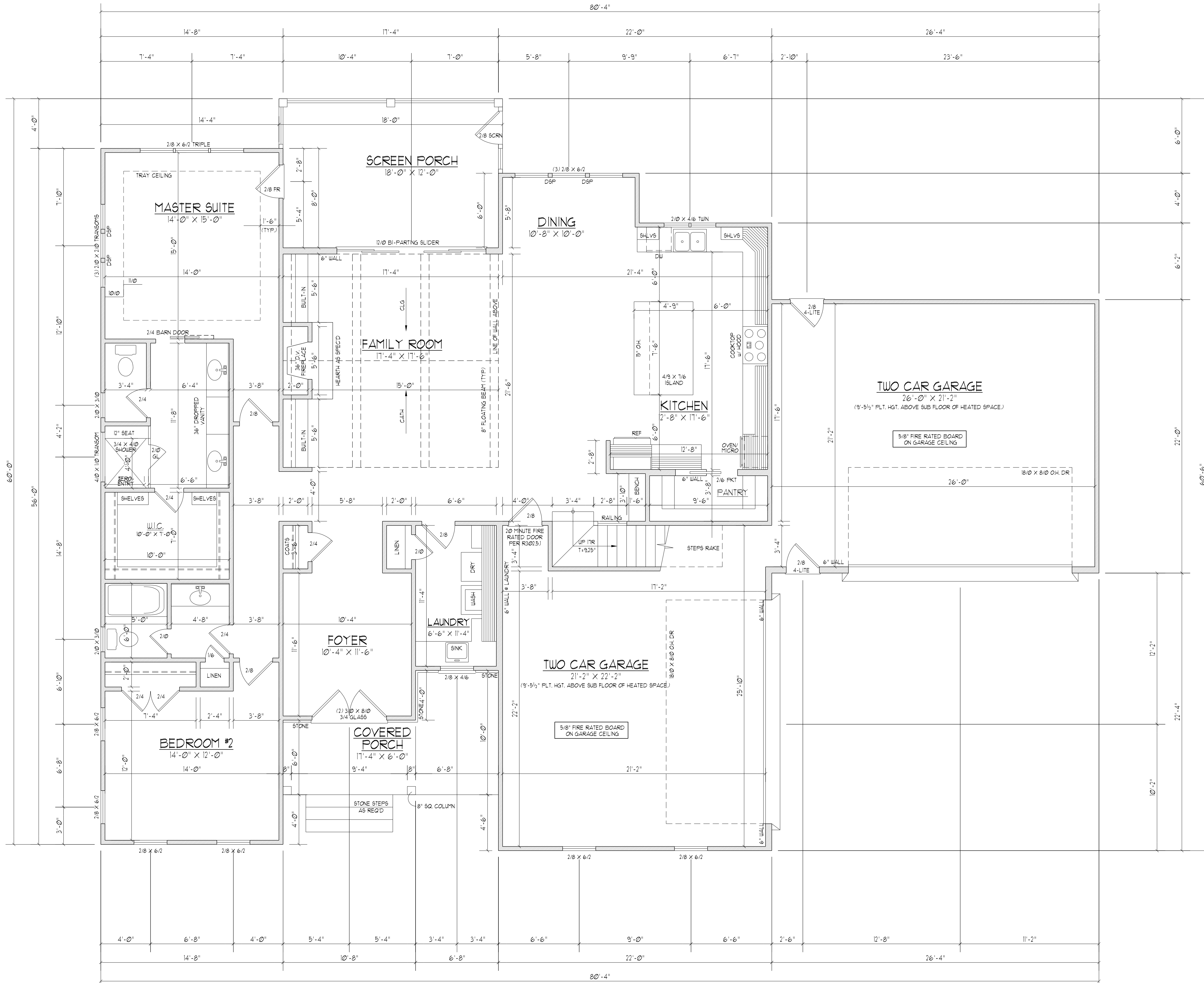

FIRST FLOOR PLAN  
 SCALE: 1/4" = 1'-0"

3060 HEATED SQ. FT.  
 109 SQ. FT. GARAGE  
 131 SQ. FT. COVERED PORCH  
 211 SQ. FT. SCREEN PORCH

- NOTES:
- 1) 10'-0" CLG. HGT. (10' - 1 1/2" FLT. HGT.) UNLESS OTHERWISE NOTED.
  - 2) ALL WALLS FIGURED AT 4" WIDTHS
  - 3) SET WINDOWS AT 8'-0" A.S.F. UNLESS OTHERWISE NOTED.
  - 4) DIMENSIONS ARE TO FRAMING UNLESS OTHERWISE NOTED.
  - 5) CONSULT WINDOW MANUFACTURER'S SPECS FOR EGRESS REQUIREMENTS, PRESSURE RATINGS, & ROUGH OPENINGS.
  - 6) ELECTRICAL BY BUILDER.

David D Grorud  
 (919) 601-1406  
 DynamicDesignGroup@gmail.com  
 www.DynamicDesignGroupInc.com

The drawings and specifications (plans) contained on these pages are the property of Dynamic Design Group and are offered to the named client or contractor for a conditional one time use. The conditional use is limited to the lot and subdivision specified herein, and only for said location. COPYRIGHT 2024  
 Contractor shall verify all conditions and dimensions prior to construction. Any error or omissions shall be reported to Dynamic Design Group for corrections or justification. Once construction has commenced, the contractor shall assume all responsibility. Dimensions govern over scale, code governs over dimensions.

KEN HARVEY  
 PROJECT FOR: HOMES  
 LOCATION: FUQUAY VARINA, NC  
 LOT: 51  
 SUBDIVISION: COTTON FARMS  
 COUNTY: WAKE

**LAVORE**

PLAN NAME

A1-3283-81GR 5.8.24

DATE

PLAN I.D.

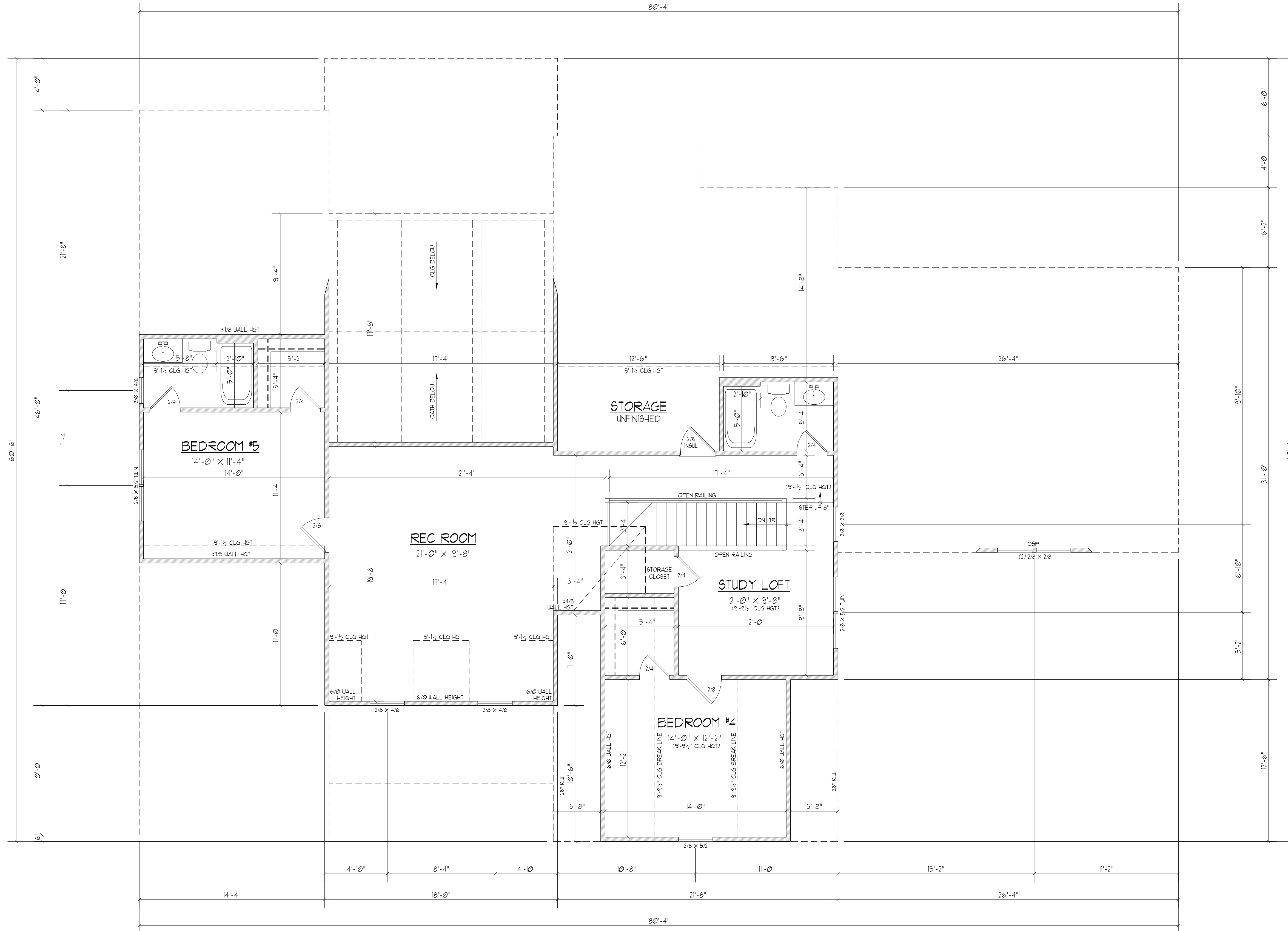

**SECOND FLOOR PLAN**

SCALE ..... 1/4"=1'-0"

123 H.T.D. SQ. FT.  
 208 H.V.A.C. / STORAGE AREA SQ. FT.

- NOTES:**
- 1) 9'-0" CLG. HGT. (9' - 1 1/2" PLT. HGT.) UNLESS OTHERWISE NOTED.
  - 2) ALL WALLS FIGURED AT 4" WIDTHS UNLESS OTHERWISE NOTED.
  - 3) SET WINDOWS AT 2'-0" A.S.F. UNLESS OTHERWISE NOTED.
  - 4) DIMENSIONS ARE TO FRAMING UNLESS OTHERWISE NOTED.
  - 5) CONSULT WINDOW MANUFACTURER'S SPECS. FOR EGRESS REQUIREMENTS, PRESSURE RATINGS, & ROUGH OPENG'S.
  - 6) ELECTRICAL BY BUILDER

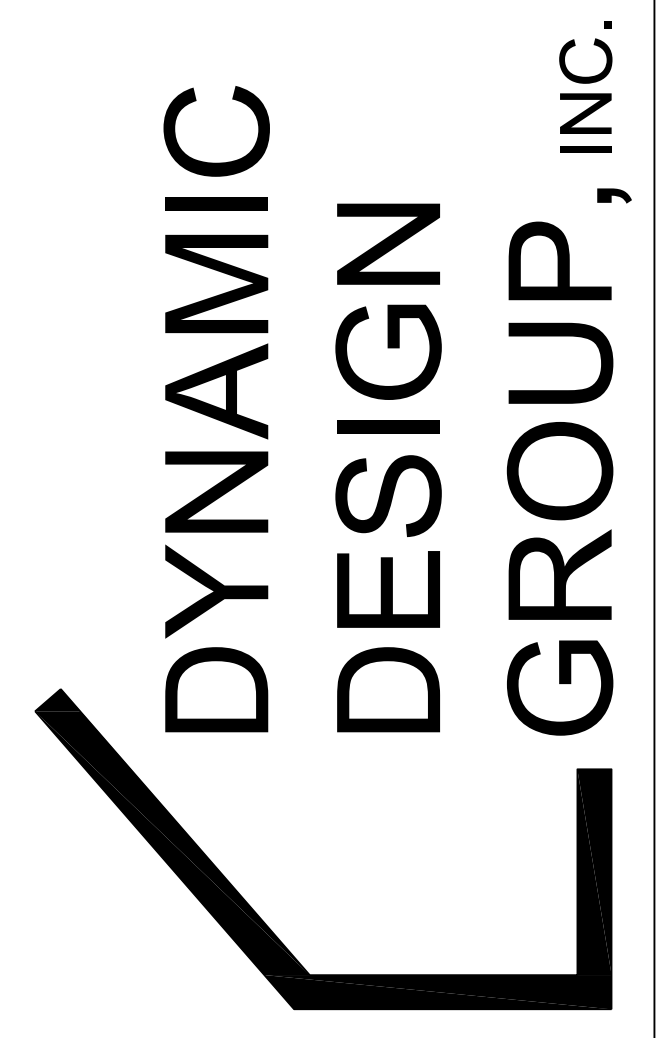

David D Grorud  
 (919) 601-1406  
 DynamicDesignGroup@gmail.com  
 www.DynamicDesignGroupInc.com

The drawings and specifications (plans) contained on these pages are the property of Dynamic Design Group and are offered to the named client or contractor for a conditional one time use. The conditional use is limited to the lot and subdivision specified herein, and only for said location. COPYRIGHT 2024  
 Contractor shall verify all conditions and dimensions prior to construction. Any error or omissions shall be reported to Dynamic Design Group for corrections or justification. Once construction has commenced, the contractor shall assume all responsibility. Dimensions govern over scale, code governs over dimensions.

**KEN HARVEY**  
 PROJECT FOR: HOMES  
 LOCATION: FUQUAY VARINA, NC  
 LOT: 51  
 SUBDIVISION: COTTON FARMS  
 COUNTY: WAKE

**LAVORE**  
 PLAN NAME  
**A1-3283-81GR** 5.8.24  
 PLAN I.D. DATE

**A-3**  
 SHEET

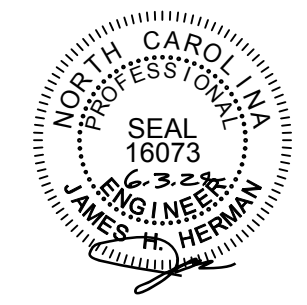

Engineers seal applies only to structural components on this document.  
Seal does not include construction means, methods, techniques, sequences, procedures or safety precautions.  
Any deviations or discrepancies on plans are to be brought to the immediate attention of Southern Engineers. Failure to do so will void Southern Engineer's liability.  
Seal is valid for projects permitted one year from date of seal.  
Use of these plans constitutes approval of terms & conditions as defined in the customer agreement.

**Southern Engineers, P.A.**  
3716 Benson Drive, Raleigh, NC 27609  
Phone: (919) 878-1617  
License: C-4772  
www.southernengineers.com

**DYNAMIC  
DESIGN  
GROUP**

**Lot 51, Cotton Farms**  
"L'Avant"  
KEN HARVEY HOMES

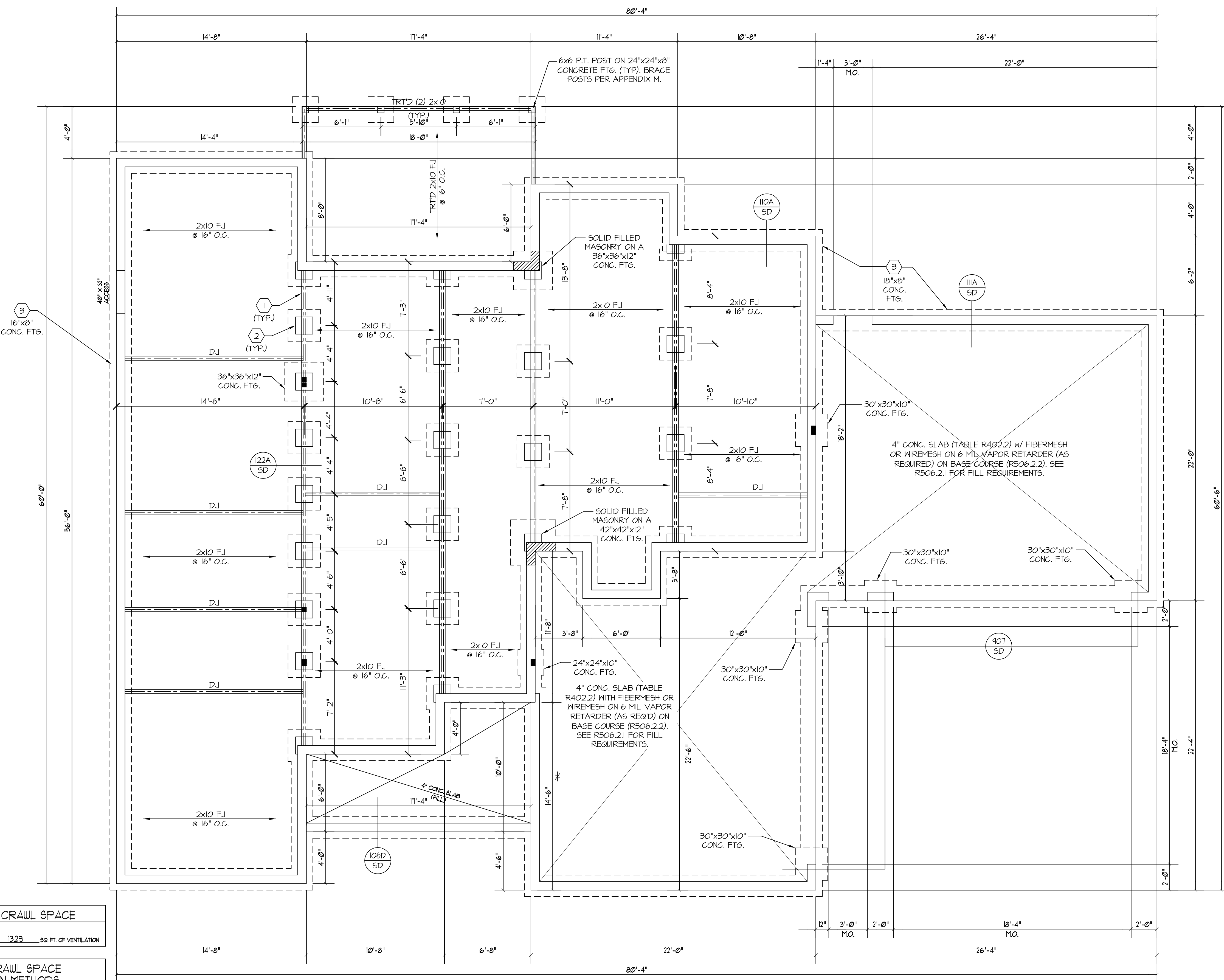

- FOUNDATION STRUCTURAL NOTES**  
NC (2018 NCRG); Wind: 115-120 mph - CRAWL
- (3) 2x10 SYP#2 OR SPF#2 GIRDER, TYPICAL UNO.
  - CONCRETE BLOCK PIER SIZE SHALL BE:  

SIZE	HOLLOW	SOLID
8x16	UP TO 32"	UP TO 5'-0"
12x16	UP TO 48"	UP TO 9'-0"
16x16	UP TO 64"	UP TO 12'-0"
24x24	UP TO 96"	

    - WITH 30" x 30" x 10" CONCRETE FOOTING, UNO.
  - WALL FOOTING AS FOLLOWS  

DEPTH:	8" - UP TO 2 STORY	10" - 3 STORY
WIDTH:	20" - 3 STORY	
SIDING:	16" - UP TO 2 STORY	20" - 3 STORY
BRICK:	16" - 1 STORY	20" - 2 STORY
	24" - 3 STORY	

    - FOR FOUNDATION WALL HEIGHT AND BACKFILL REQUIREMENTS, REFER TO CODE TABLE R404.1.1 (1 THRU 4) NOTE: ASSUMED SOIL BEARING CAPACITY = 2000 PSF. CONTRACTOR MUST VERIFY SITE CONDITIONS AND CONTACT SOILS ENGINEER IF MARGINAL OR UNSTABLE SOILS ARE ENCOUNTERED.
  - (4) 2x10 SPF #2 OR SYP #2 GIRDER
  - (2) 1.75x9.25 LVL OR LSL GIRDER
  - (3) 1.75x9.25 LVL OR LSL GIRDER
  - "■" DESIGNATES A SIGNIFICANT POINT LOAD TO HAVE SOLID BLOCKING TO PIER. SOLID BLOCK ALL BEAM BEARING POINTS NOTED TO HAVE THREE OR MORE STUDS TO FND, TYPICAL.
  - ABBREVIATIONS:  
    - "S.J." = SINGLE JOIST
    - "D.J." = DOUBLE JOIST
    - "T.J." = TRIPLE JOIST
  - ADJUST SUBFLOOR THICKNESS OR JOIST SPACING AS REQ'D FOR FLOOR FINISH MATERIALS.

**WALL VENTED CRAWL SPACE**

REQUIRED	2060	SQ. FT. / 50'	1329	SQ. FT. OF VENTILATION
----------	------	---------------	------	------------------------

**CLOSED CRAWL SPACE VENTILATION METHODS**  
(SEE REFERENCED SECTIONS IN CODE BOOK FOR DETAILED INSTRUCTIONS)

(R409.5.1) DEHUMIDIFIER	A PERMANENTLY INSTALLED DEHUMIDIFIER SHALL BE PROVIDED IN THE CRAWL SPACE WITH THE MINIMUM RATED CAPACITY OF 15 PINTS PER DAY.			
(R409.5.2) SUPPLY AIR	2060	SQ. FT. / 30'	10	CFM
(R409.5.3) HOUSE AIR	2060	SQ. FT. / 50'	42	CFM
(R409.5.4) EXHAUST FAN	2060	SQ. FT. / 50'	42	CFM
(R409.5.5) CONDITIONED SPACE	THE CRAWL SPACE SHALL BE DESIGNED AS A HEATED AND COOLED, CONDITIONED SPACE WITH WALL INSULATION INSTALLED AS PER THE REQUIREMENTS OF SECTION R409.5.1.			

**FOUNDATION STRUCTURAL PLAN**  
SCALE: 1/4" = 1'-0"  
REFER TO "SD" SHEET(S) FOR STANDARD DETAILS AND STRUCTURAL NOTES

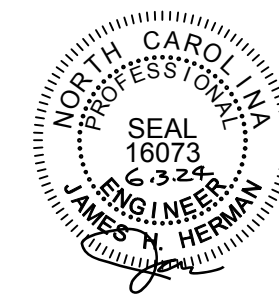

PROJECT #  
24-1493

Engineers seal applies only to structural components on this document.  
Seal does not include construction means, methods, techniques, sequences, procedures or safety precautions.  
Any deviations or discrepancies on plans are to be brought to the immediate attention of Southern Engineers. Failure to do so will void Southern Engineer's liability.  
Seal is valid for projects permitted one year from date of seal.  
Use of these plans constitutes approval of terms & conditions as defined in the customer agreement.

**Southern Engineers, P.A.**  
3716 Benson Drive, Raleigh, NC 27609  
Phone: (919) 878-1617  
License: C-4772  
www.southernengineers.com

**DYNAMIC  
DESIGN  
GROUP**

**Lot 51, Cotton Farms  
"Lavore"**  
KEN HARVEY HOMES

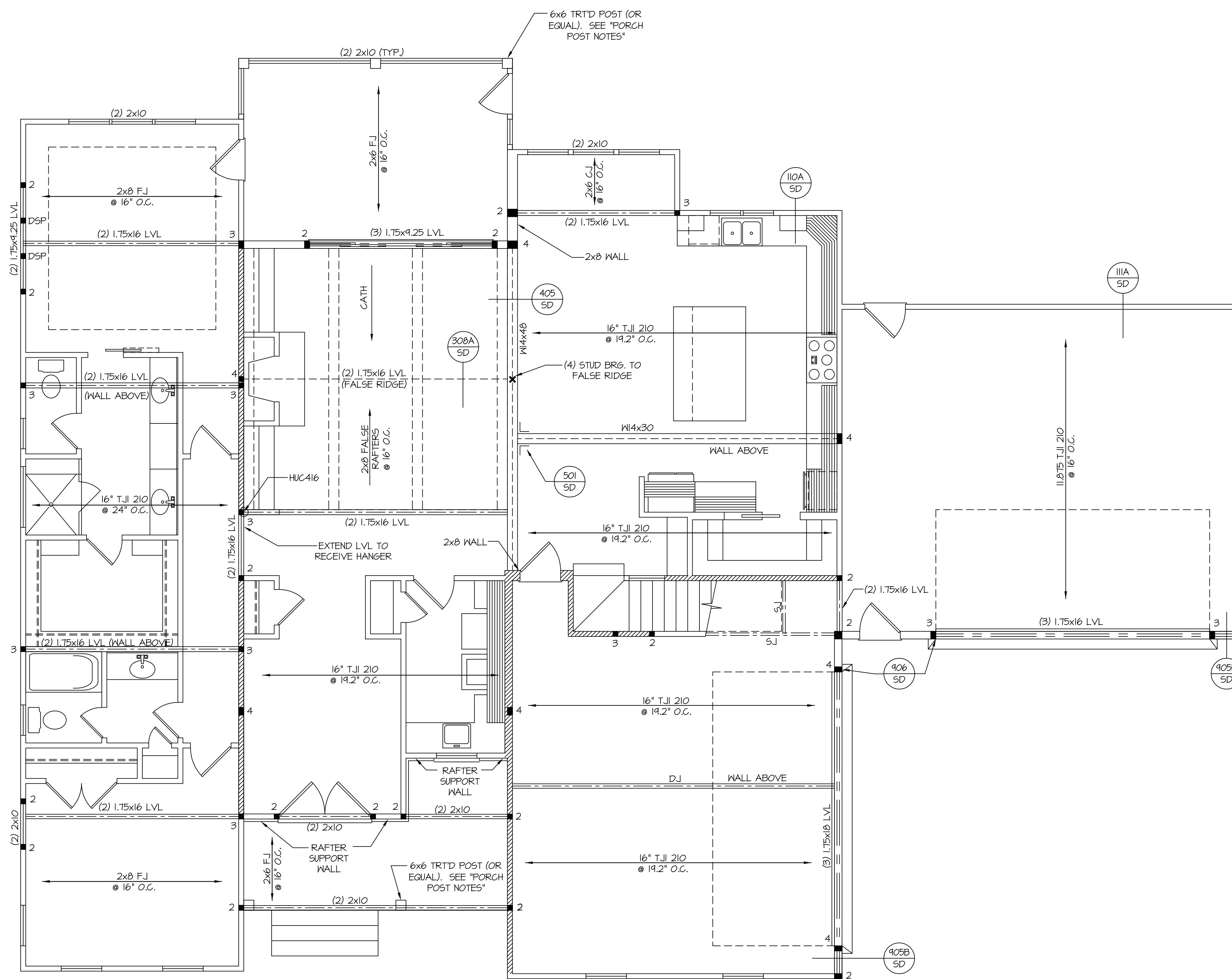

FIRST FLOOR STRUCTURAL PLAN

SCALE: 1/4" = 1'-0"

REFER TO "SD" SHEET(S) FOR STANDARD DETAILS AND STRUCTURAL NOTES

S-2

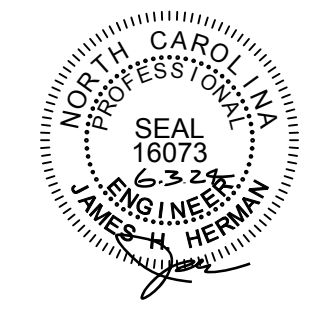
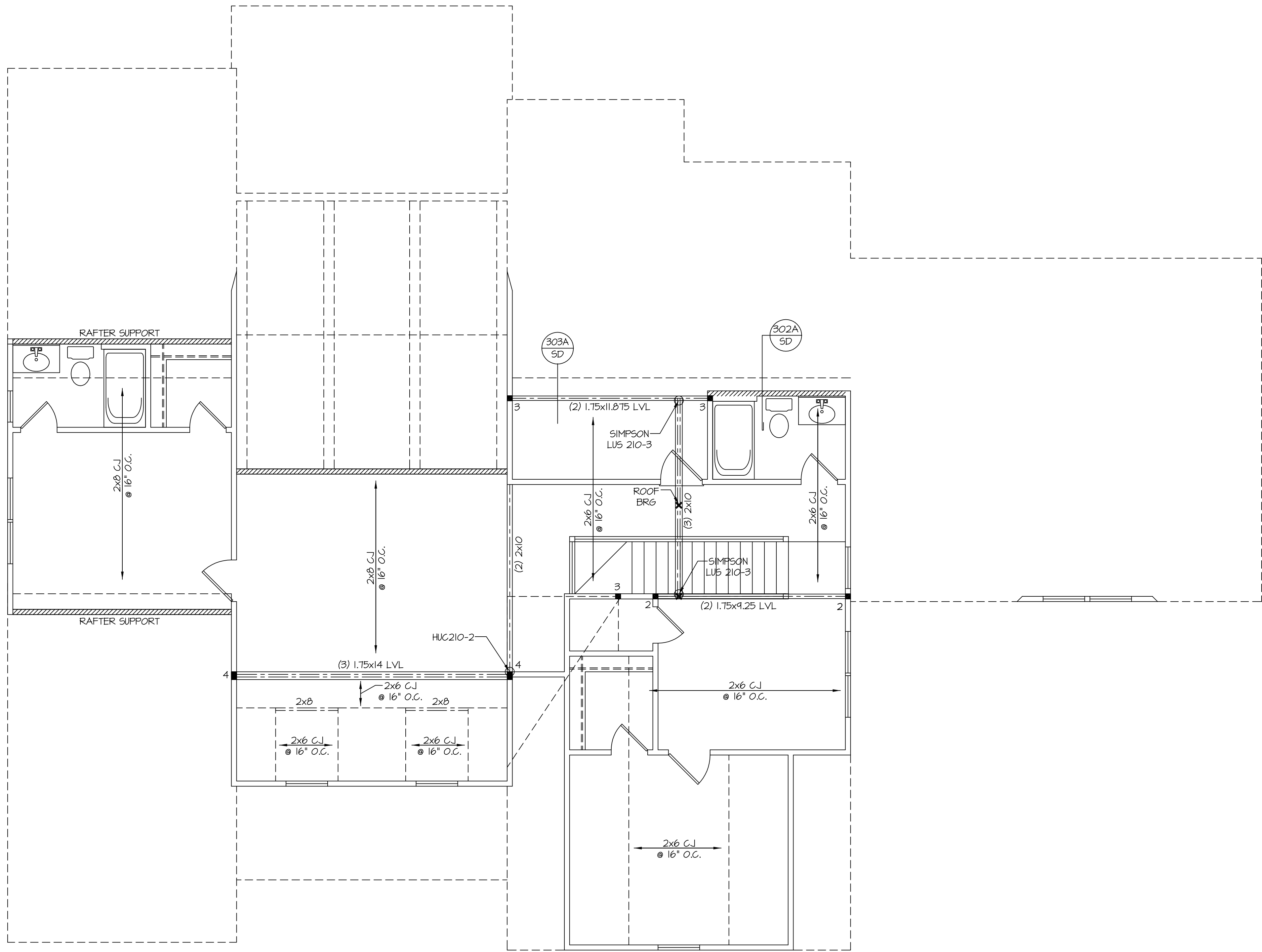

**PROJECT #**  
24-1493

Engineers seal applies only to structural components on this document.  
Seal does not include construction means, methods, techniques, sequences, procedures or safety precautions.  
Any deviations or discrepancies on plans are to be brought to the immediate attention of Southern Engineers. Failure to do so will void Southern Engineer's liability.  
Seal is valid for projects permitted one year from date of seal.  
Use of these plans constitutes approval of terms & conditions as defined in the customer agreement.

**Southern Engineers, P.A.**  
3716 Benson Drive, Raleigh, NC 27609  
Phone: (919) 878-1617  
License: C-4772  
www.southernengineers.com

**DYNAMIC  
DESIGN  
GROUP**

**Lot 51, Cotton Farms**  
"Lavore"  
**KEN HARVEY HOMES**

**S-3**

**SECOND FLOOR STRUCTURAL PLAN**  
SCALE: 1/4"=1'-0"  
REFER TO "SD" SHEET(S) FOR STANDARD DETAILS AND STRUCTURAL NOTES

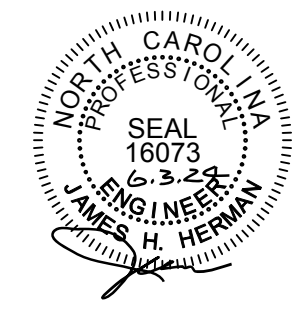

ATTIC VENTILATION						
REQUIRED	3531	SQ FT OF ATTIC / 300 =	11.77	SQ FT. OF INLET & OUTLET		
PROVIDED (INLET)	27	SQ FT. PER X	120	LINEAR FT. OF VENT. = 840	SQ FT. OF VENT. = 46	% (TOTAL OF INLET)
PROVIDED (OUTLET)	11	SQ FT. PER X	88	LINEAR FT. OF VENT. = 968	SQ FT. OF VENT. = 54	% (TOTAL OF OUTLET)
				1808	TOTAL SQ. FT. OF VENT.	

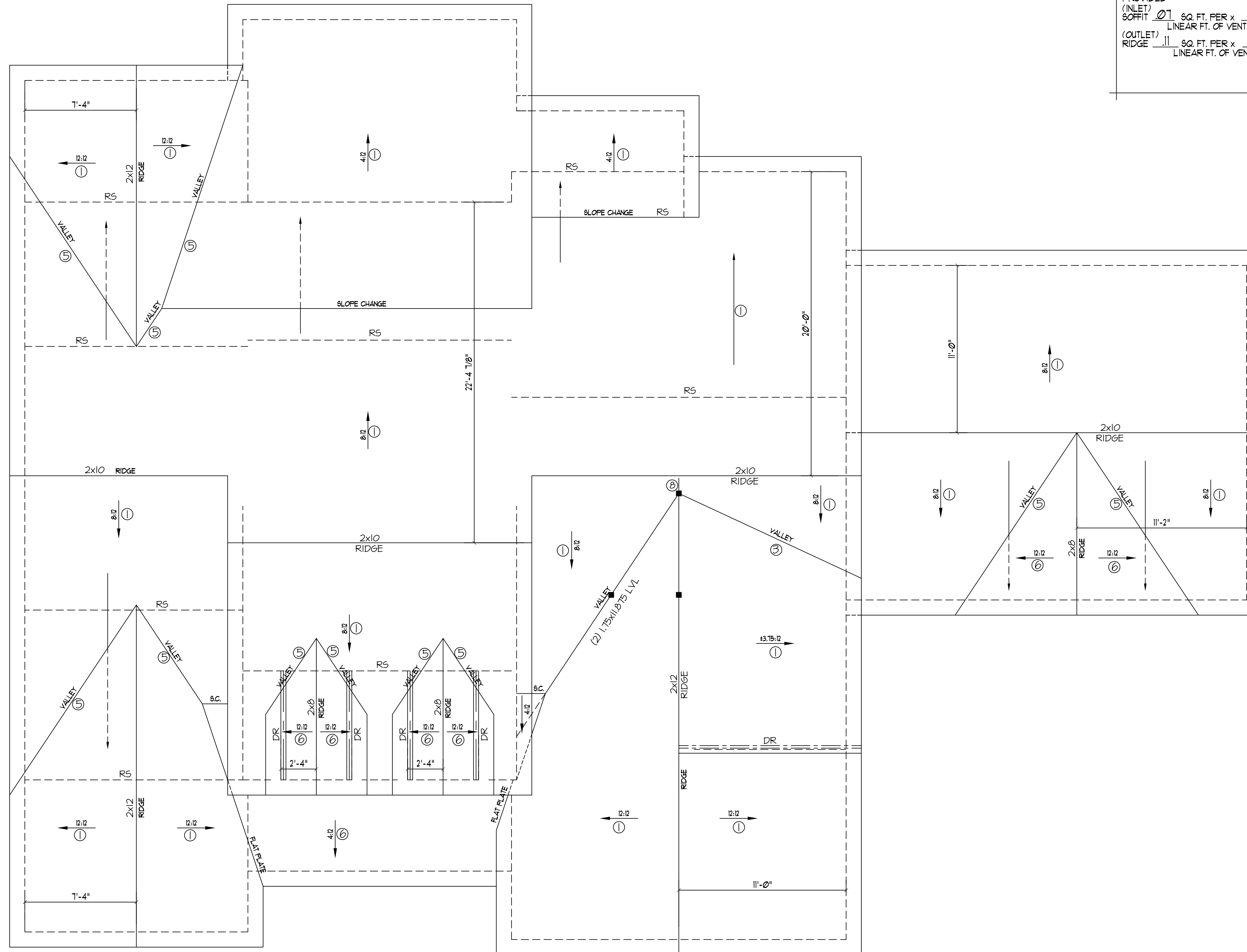

**ROOF FRAMING NOTES:**

NC (2018 NCRG); Wind: 115-120 mph

- ① 2x8 RAFTERS @ 16" O.C. WITH 2x10 RIDGE, UNO.
  - ② (2) 2x10 OR 1.75x11.875 LVL HIP. (2) 2x10 HIPs MAY BE SPLICED WITH A MIN. 6'-0" OVERLAP AT CENTER
  - ③ (2) 2x10 OR 1.75x9.25 LVL VALLEY. DO NOT SPLICE VALLEYS
  - ④ 1.75x11.875 LVL OR (2)1.75x9.25 LVL VALLEY
  - ⑤ FALSE FRAME VALLEY ON 2x10 FLAT PLATE
  - ⑥ 2x6 RAFTERS @ 16" O.C. W/ 2x8 RIDGE, UNO.
  - ⑦ 2x10 RAFTERS @ 16" O.C. W/ 2x12 RIDGE, UNO.
  - ⑧ EXTEND RIDGE 12" BEYOND INTERSECTION
- "SR" = SINGLE RAFTER
  - "DR" = DOUBLE RAFTER
  - "TR" = TRIPLE RAFTER
  - "RS" = ROOF SUPPORT
  - ■ = (3) STUD OR 4x4 POST FOR ROOF SUPPORT (USE 2x6 STUDS OR 6x6 POST FOR SUPPORT OVER 10'-0" IN HEIGHT)
  - ATTACH VAULTED RAFTERS WITH HURRICANE CLIPS: SIMPSON "H-25A" OR EQUIVALENT. TIES TO BE INSTALLED ON THE OUTSIDE FACE OF FRAMING.
  - INSTALL RAFTER TIES AND COLLAR TIES PER SECTION R802.3.1 OF THE 2018 NC RESIDENTIAL CODE.

ROOF STRUCTURAL PLAN

SCALE: 1/4" = 1'-0"

REFER TO "SD" SHEET(S) FOR STANDARD DETAILS AND STRUCTURAL NOTES

Southern Engineers, P.A.  
3716 Benson Drive, Raleigh, NC 27609  
Phone: (919) 878-1617  
License: C-4772  
www.southernengineers.com

DYNAMIC  
DESIGN  
GROUP

Lot 51, Cotton Farms  
"L'Avore"  
KEN HARVEY HOMES

Engineers seal applies only to structural components on this document.  
Seal does not include construction means, methods, techniques, sequences, procedures or safety precautions.  
Any deviations or discrepancies on plans are to be brought to the immediate attention of Southern Engineers. Failure to do so will void Southern Engineer's liability.  
Seal is valid for projects permitted one year from date of seal.  
Use of these plans constitutes approval of terms & conditions as defined in the customer agreement.



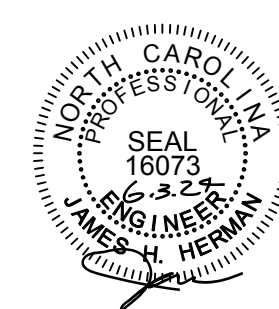

PROJECT #  
24-1493

Engineers seal applies only to structural components on this document. Seal does not include construction means, methods, techniques, sequences, procedures or safety precautions. Any deviations or discrepancies on plans are to be brought to the immediate attention of Southern Engineers. Failure to do so will void Southern Engineer's liability. Seal is valid for projects permitted one year from date of seal. Use of these plans constitutes approval of terms & conditions as defined in the customer agreement.

**Southern Engineers, P.A.**  
3716 Benson Drive, Raleigh, NC 27609  
Phone: (919) 878-1617  
License: C-4772  
www.southernengineers.com

**DYNAMIC  
DESIGN  
GROUP**

**Lot 51, Cotton Farms**  
"Lavore"  
**KEN HARVEY HOMES**

**SD**

### STRUCTURAL NOTES

NC (2018 NCR): Wind: 115-120 mph

- ENGINEER'S SEAL APPLIES ONLY TO STRUCTURAL COMPONENTS INCLUDING ROOF RAFTERS, HIPs, VALLEYS, RIDGES, FLOORS, WALLS, BEAMS AND HEADERS, COLUMNS, CANTILEVERS, OFFSET LOAD BEARING WALLS, PIER & GIRDER SYSTEM, FOOTING, AND PILING SYSTEM. ENGINEER'S SEAL DOES NOT CERTIFY DIMENSIONAL ACCURACY OR ARCHITECTURAL LAYOUT INCLUDING ROOF SYSTEM. ALL REQUIREMENTS FOR PROFESSIONAL CERTIFICATION SHALL BE PROVIDED BY THE APPROPRIATE PROFESSIONAL. SOUTHERN ENGINEERS, P.A. CERTIFIES ONLY THE STRUCTURAL COMPONENTS AS SPECIFICALLY STATED.
- ALL CONSTRUCTION SHALL CONFORM TO THE LATEST REQUIREMENTS OF THE 2018 NC RESIDENTIAL CODE, PLUS ALL LOCAL CODES AND REGULATIONS. THE STRUCTURAL ENGINEER IS NOT RESPONSIBLE FOR, AND WILL NOT HAVE CONTROL OF, CONSTRUCTION MEANS, METHODS, TECHNIQUES, SEQUENCES OR PROCEDURES, OR FOR SAFETY PRECAUTIONS AND PROGRAMS IN CONNECTION WITH THE CONSTRUCTION WORK, NOR WILL THE ENGINEER BE RESPONSIBLE FOR THE CONTRACTOR'S FAILURE TO CARRY OUT THE CONSTRUCTION WORK IN ACCORDANCE WITH THE CONTRACT DOCUMENTS. "CONSTRUCTION REVIEW" SERVICES ARE NOT PART OF OUR CONTRACT. ALL MEMBERS SHALL BE FRAMED ANCHORED, TIED AND BRACED IN ACCORDANCE WITH GOOD CONSTRUCTION PRACTICE AND THE BUILDING CODE.
- DESIGN LOADS (LISTED AS: LIVE LOAD, DEAD LOAD, DEFLECTION)
  - ROOMS OTHER THAN SLEEPING ROOMS: (40 PSF, 10 PSF, L/360)
  - SLEEPING ROOMS: (30 PSF, 10 PSF, L/360)
  - ATTIC WITH PERMANENT STAIR: (40 PSF, 10 PSF, L/360)
  - ATTIC WITHOUT PERMANENT STAIR: (20 PSF, 10 PSF, L/360)
  - ATTIC WITHOUT STORAGE: (10 PSF, 10 PSF, L/240)
  - STAIRS: (40 PSF, 10 PSF, L/360)
  - DECKS AND EXTERIOR BALCONIES: (40 PSF, 10 PSF, L/360)
  - PASSENGER VEHICLE GARAGES: (50 PSF, 10 PSF, L/360)
  - SNOW: (20 PSF)
- WALLS SHALL BE BRACED BY SHEATHING WALLS ON ALL STORIES WITH WOOD STRUCTURAL PANELS. SEE FRAMING NOTES FOR THICKNESS AND NAILING REQUIREMENTS.
- SEE APPENDIX M (DGA6) FOR EXTERIOR DECK REQUIREMENTS INCLUDING ATTACHMENTS FOR LATERAL LOADS.
- CONCRETE SHALL HAVE A MINIMUM 28 DAY STRENGTH OF 3000 PSI AND A MAXIMUM SLUMP OF 5 INCHES UNLESS NOTED OTHERWISE (UNO). AIR ENTRAINED PER TABLE 402.2. ALL CONCRETE SHALL BE PROPORTIONED, MIXED, HANDLED, SAMPLED, TESTED, AND PLACED IN ACCORDANCE WITH ACI STANDARDS. ALL SAMPLES FOR PUMPING SHALL BE TAKEN FROM THE EXIT END OF THE PUMP. CONTROL JOINTS IN SLABS SHALL BE SPACED ON A GRID OF +30 TIMES THE DEPTH (D). CONTROL JOINTS SHALL BE SAWCUT TO A DEPTH OF 1/3. (I.E. 4" CONCRETE SLABS SHALL HAVE 1/4" DEEP CONTROL JOINTS SAWCUT IN SLAB ON A +10'-0" x +10'-0" GRID).
- ALLOWABLE SOIL BEARING PRESSURE ASSUMED TO BE 2000 PSF. THE CONTRACTOR MUST CONTACT A GEOTECHNICAL ENGINEER AND THE STRUCTURAL ENGINEER IF UNSATISFACTORY SUBSURFACE CONDITIONS ARE ENCOUNTERED. THE SURFACE AREA ADJACENT TO THE FOUNDATION WALL SHALL BE PROVIDED WITH ADEQUATE DRAINAGE, AND SHALL BE GRADED SO AS TO DRAIN SURFACE WATER AWAY FROM FOUNDATION WALLS.
- ALL FRAMING LUMBER SHALL BE SPF #2 (Fb = 875 PSI) UNLESS NOTED OTHERWISE (UNO). ALL TREATED LUMBER SHALL BE SYP # 2. PLATE MATERIAL MAY BE SPF # 3 OR SYP #3 (F<sub>c</sub>perp) = 425 PSI - MIN.
  - L.V.L. SHALL BE LAMINATED VENEER LUMBER: Fb=2600 PSI, Fv=285 PSI, E=1.9x10<sup>6</sup> PSI.
  - P.S.L. SHALL BE PARALLEL STRAND LUMBER: Fb=2400 PSI, Fv=240 PSI, E=2.0x10<sup>6</sup> PSI.
  - L.S.L. SHALL BE LAMINATED STRAND LUMBER: Fb=2250 PSI, Fv=400 PSI, E=1.55x10<sup>6</sup> PSI. INSTALL ALL CONNECTIONS PER MANUFACTURER'S INSTRUCTIONS.
- ALL ROOF TRUSS AND I-JOIST LAYOUTS SHALL BE PREPARED IN ACCORDANCE WITH THE SEALED STRUCTURAL DRAWINGS. TRUSSES AND I-JOISTS SHALL BE INSTALLED ACCORDING TO THE MANUFACTURER'S SPECIFICATIONS. ANY CHANGE IN TRUSS OR I-JOIST LAYOUT SHALL BE COORDINATED WITH SOUTHERN ENGINEERS.
- ALL STRUCTURAL STEEL SHALL BE ASTM A-36. STEEL BEAMS SHALL BE SUPPORTED AT EACH END WITH A MINIMUM BEARING LENGTH OF 3 1/2" INCHES AND FULL FLANGE WIDTH. PROVIDE SOLID BEARING FROM BEAM SUPPORT TO FOUNDATION. BEAMS SHALL BE ATTACHED TO EACH SUPPORT WITH TWO LAG SCREWS (1/2" DIAMETER x 4" LONG). LATERAL SUPPORT IS CONSIDERED ADEQUATE PROVIDING THE JOIST ARE TOE NAILED TO THE SOLE PLATE, AND SOLE PLATE IS NAILED OR BOLTED TO THE BEAM FLANGE @ 48" O.C. ALL STEEL TUBING SHALL BE ASTM A500.
- REBAR SHALL BE DEFORMED STEEL, ASTM615, GRADE 60. LAP ALL REBAR SPLICES 30 BAR DIAMETERS.
- FLITCH BEAMS SHALL BE BOLTED TOGETHER USING (2) ROWS OF 1/2" DIAMETER BOLTS (ASTM A325) WITH WASHERS PLACED UNDER THE THREADED END OF BOLT. BOLTS SHALL BE SPACED AT 24" O.C. (MAX), AND STAGGERED AT THE TOP AND BOTTOM OF BEAM (2" EDGE DISTANCE), WITH 2 BOLTS LOCATED AT 6" FROM EACH END.
- BRICK LINTELS (WHEN REQUIRED) SHALL BE 3 1/2"x3 1/2"x1/4" STEEL ANGLE FOR UP TO 6'-0" SPAN AND 6"x4"x5/16" STEEL ANGLE WITH 6" LEG VERTICAL FOR SPANS UP TO 4'-0". SEE PLANS FOR SPANS OVER 4'-0". SEE ALSO SECTION R103.03 LINTELS.
- METAL CONNECTORS REFERENCED ON PLANS CORRESPOND TO SIMPSON STRONG-TIE BRAND. CONNECTORS OF EQUAL OR BETTER CAPACITY ARE ACCEPTABLE. CORROSION RESISTANCE PER CODE AND AS RECOMMENDED BY MANUFACTURER.

### FRAMING NOTES

NC (2018 NCR): Wind: 115-120 mph

- BRACING METHOD AND TYPE: CONTINUOUSLY SHEATHED WSP, CS-WSP. NOTE THAT THE WALL BRACING AMOUNT PROVIDED ON THE PLANS (DETAILS AND SPECIFICATIONS) IS GREATER THAN THE AMOUNT OF WALL BRACING REQUIRED BY SECTION R602.10.4 OF THE CODE. SEE NOTES BELOW FOR DETAILS AND SPECIFICATIONS FOR WALL BRACING AND WALL FRAMING.
- EXTERIOR WALL SHEATHING: WALLS SHALL BE BRACED BY SHEATHING WALLS ON ALL STORIES WITH WOOD STRUCTURAL PANEL SHEATHING (WSP) (EXPOSURE B: 7/16", EXPOSURE C: 15/32"). SHEATHING SHALL BE ATTACHED WITH 8d NAILS AT A 6"/12" NAILING PATTERN (6" OC AT PANEL EDGES AND 12" OC AT INTERMEDIATE SUPPORTS). INSTALL BLOCKING AT ALL PANEL EDGES.
- WSP SHEATHING SHALL EXTEND TO THE UPPERMOST DOUBLE BEARING PLATE, BLOCK AT ROOF PER SECTION R602.10.4.5 AND ATTACH BRACED WALLS PER CODE. WSP SHEATHING BETWEEN FLOORS SHALL BE SPLICED ALONG CONTINUOUS BAND OR THE WSP SHEATHING MAY BE SPLICED ACROSS STUDS (CONTINUOUS ACROSS FLOOR SYSTEM) WITH BLOCKING AT PANEL EDGES. (MINIMUM 12" BEYOND FLOOR BREAK) OR OTHER APPROVED METHOD.
- "HD" = HOLD-DOWN: HOLD-DOWN DEVICE (NOTED AS "HD" ON PLANS) SHALL BE AN 800 POUND CAPACITY ASSEMBLY AS NOTED ON PLANS. SEE DETAILS FOR HD ASSEMBLY.
  - \*\*GROUND/FIRST FLOOR: USE "HD HOLD-DOWN DETAIL" ON SD SHEET (OR EQUIV)
  - \*\*UPPER FLOORS: ATTACH BASE OF KING STUD WITH A SIMPSON CS20 OR CSH20 STRAP DOWN ACROSS THE BAND AND DOWN TO A STUD BELOW OR HEADER BELOW. EXTEND STRAP 7" MIN ALONG EACH STUD (OR HEADER) AND ATTACH EACH END W/ (7) 8d NAILS.
- INTERIOR BRACED WALL: (NOTED AS "IBW" ON PLANS) ATTACH 1/2" GYPSUM BOARD (GB) ON EACH SIDE OF WALL WITH A MIN. OF 5d COOLER NAILS OR #6 SCREWS @ 7" O.C. ALONG THE EDGES AND AT INTERMEDIATE SUPPORTS. SEE SECTION R602.10.4.4 OF THE CODE.
- INTERIOR BRACED WALL-WOOD STRUCTURAL PANEL: (NOTED AS "IBW-WSP" ON PLANS). ATTACH ONE SIDE WITH 3/4" WSP SHEATHING WITH 8d NAILS AT A 6"/12" NAILING PATTERN (6" OC AT PANEL EDGES AND 12" OC AT INTERMEDIATE SUPPORTS). INSTALL BLOCKING AT ALL PANEL EDGES. ATTACH GB OVER WSP AS REQUIRED. ATTACH OPPOSITE SIDE WITH 1/2" GB WITH A MIN. OF 5d COOLER NAILS OR #6 SCREWS @ 7" OC ALONG THE EDGES AND AT INTERMEDIATE SUPPORTS. SEE SECTION R602.10.4.4 OF THE CODE.

### HEADER/BEAM & COLUMN NOTES

- ALL EXTERIOR AND LOAD BEARING HEADERS SHALL BE MIN. (2)2x10 (4" WALL) OR (3)2x10 (6" WALL) WITH (1) SUPPORT STUD, UNLESS NOTED OTHERWISE.
- THE NUMBER SHOWN AT BEAM AND HEADER SUPPORTS INDICATES THE NUMBER OF SUPPORT STUDS REQUIRED IN STUD POCKET OR COLUMN. THE NUMBER OF KING STUDS AT EACH END OF HEADERS IN EXTERIOR WALLS SHALL BE ACCORDING TO ITEM "d" IN TABLE R602.3(5) OR AS BELOW PER NCDOT COMMENTARY "KING STUDS AT WALL OPENINGS" REVISED 1-4-2020:
  - UP TO 3' SPAN: (1) KING STUD
  - OVER 3' UP TO 6' SPAN: (2) KING STUDS
  - OVER 6' UP TO 9' SPAN: (3) KING STUDS
  - OVER 9' UP TO 12' SPAN: (4) KING STUDS
  - OVER 12' UP TO 15' SPAN: (5) KING STUDS

### TRUSS SYSTEM REQUIREMENTS

NC (2018 NCR): Wind: 115-120 mph

- TRUSS SYSTEM LAYOUTS (PLACEMENT PLANS) SHALL BE DESIGNED IN ACCORDANCE WITH SEALED STRUCTURAL PLANS. ANY NEED TO CHANGE TRUSSES SHALL BE COORDINATED WITH SOUTHERN ENGINEERS.
- TRUSS SCHEMATICS (PROFILES) SHALL BE PREPARED AND SEALED BY TRUSS MANUFACTURER.
- ALL TRUSSES SHALL BE DESIGNED FOR BEARING ON SPF #2 OR #3 PLATES OR LEDGERS (UNO).
- ALL REQUIRED ANCHORS FOR TRUSSES DUE TO UPLIFT OR BEARING SHALL MEET THE REQUIREMENTS AS SPECIFIED ON THE TRUSS SCHEMATICS.

### WOOD I-JOISTS

(SHALL BE ONE OF THE FOLLOWING):

- TJI 210 BY TRUS JOIST
- LPI 20 PLUS BY LP
- BC1 5000s LB BY BC
- BLI 40 BY ONCENTER

- ALL I-JOISTS SHALL BE INSTALLED ACCORDING TO MANUFACTURER'S SPECIFICATIONS.
- INSTALL SQUASH BLOCKS, WEB STIFFENERS, ETC. AS REQUIRED BY AND ACCORDING TO THE I-JOIST MANUFACTURER'S SPECIFICATIONS AND INSTRUCTIONS.
- HANGERS FOR I-JOISTS ARE THE RESPONSIBILITY OF THE I-JOIST SUPPLIER.

NOTE: I-JOISTS MAY BE SUBSTITUTED WITH FLOOR TRUSSES DESIGNED BY SUPPLIER (SAME DEPTH AND LAYOUT).

### PORCH POST NOTES:

- 4X4 (6x6) TRTD POST (OR EQUAL).
- ATTACH TRUSSES (RAFTERS) AT PORCH WITH HURRICANE CONNECTORS.
  - POST CAP: SIMPSON AC4-MAX (AC6-MAX)
  - POST CAP AT CORNER: (2) SIMPSON LCE4 (MITER HEADER AT CORNER). HIGH WIND; ADD (1) SIMPSON H6.
  - POST BASE: SIMPSON ABU44 (ABU66).
    - MONO: 3/8" ANCHOR (EMBED 7")
    - CMU: 3/8" ANCHOR (EXTEND TO FOOTING - HIGH WIND ONLY)
  - POST BASE: WOOD FOUNDATION: (2) SIMPSON CS16 STRAPS AT POSTS. EXTEND 12" ONTO EACH POST (UPPER AND LOWER) OR TO GIRDER.
- NOTE: THE ABOVE CONNECTORS ARE SUGGESTIONS. EQUIVALENT CONNECTORS THAT MEET THE REQUIREMENTS OF THE NC RESIDENTIAL BUILDING CODE, LOCAL CODES, AND/OR ARE APPROVED BY THE BUILDING INSPECTOR MAY BE SUBSTITUTED.

### LVL CONNECTION LEGEND

- (2) PLY 1.75" LVL BEAMS:
  - (3) ROWS OF 10d NAILS @ 12" O.C. OR
  - (2) ROWS OF SIMPSON SDW22338 (OR EQUAL) SCREWS @ 16" O.C. FOR BEAMS UP TO 18"
  - (3) ROWS OF SIMPSON SDW22338 (OR EQUAL) SCREWS @ 16" O.C. FOR BEAMS GREATER THAN 18".
- (3) PLY 1.75" LVL BEAMS:
  - (3) ROWS OF 10d NAILS @ 8" O.C. ON EACH SIDE OR
  - (2) ROWS OF SIMPSON SDW22500 (OR EQUAL) SCREWS @ 16" O.C. FOR BEAMS UP TO 18"
  - (3) ROWS OF SIMPSON SDW22500 (OR EQUAL) SCREWS @ 16" O.C. FOR BEAMS GREATER THAN 18".
- (4) PLY 1.75" LVL BEAMS:
  - (2) ROWS OF SIMPSON SDW22634 (OR EQUAL) SCREWS @ 16" O.C. FOR BEAMS UP TO 18"
  - (3) ROWS OF SIMPSON SDW22634 (OR EQUAL) SCREWS @ 16" O.C. FOR BEAMS GREATER THAN 18".

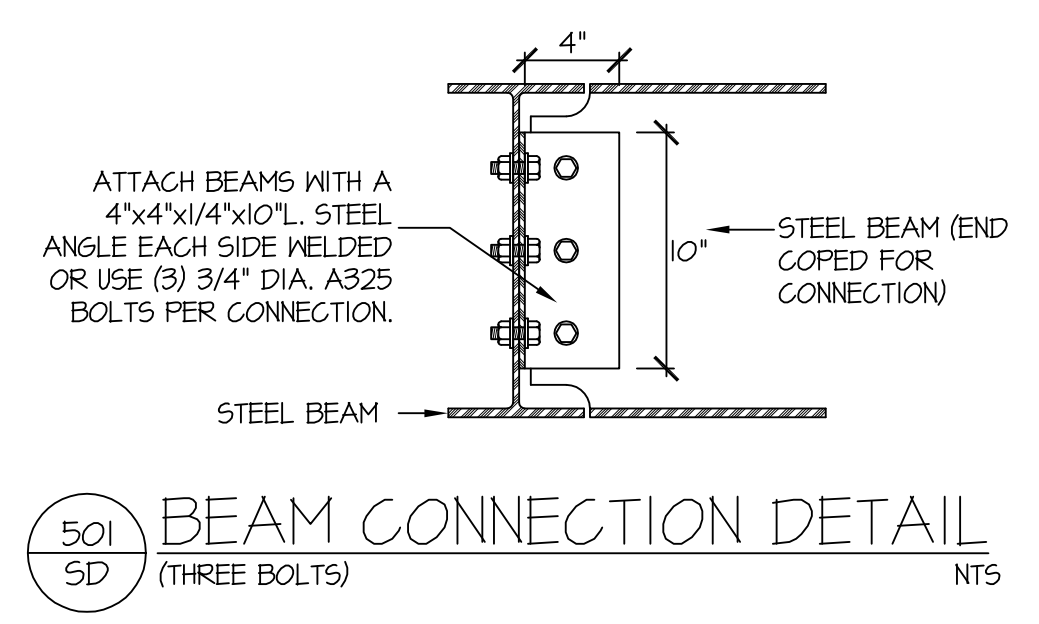
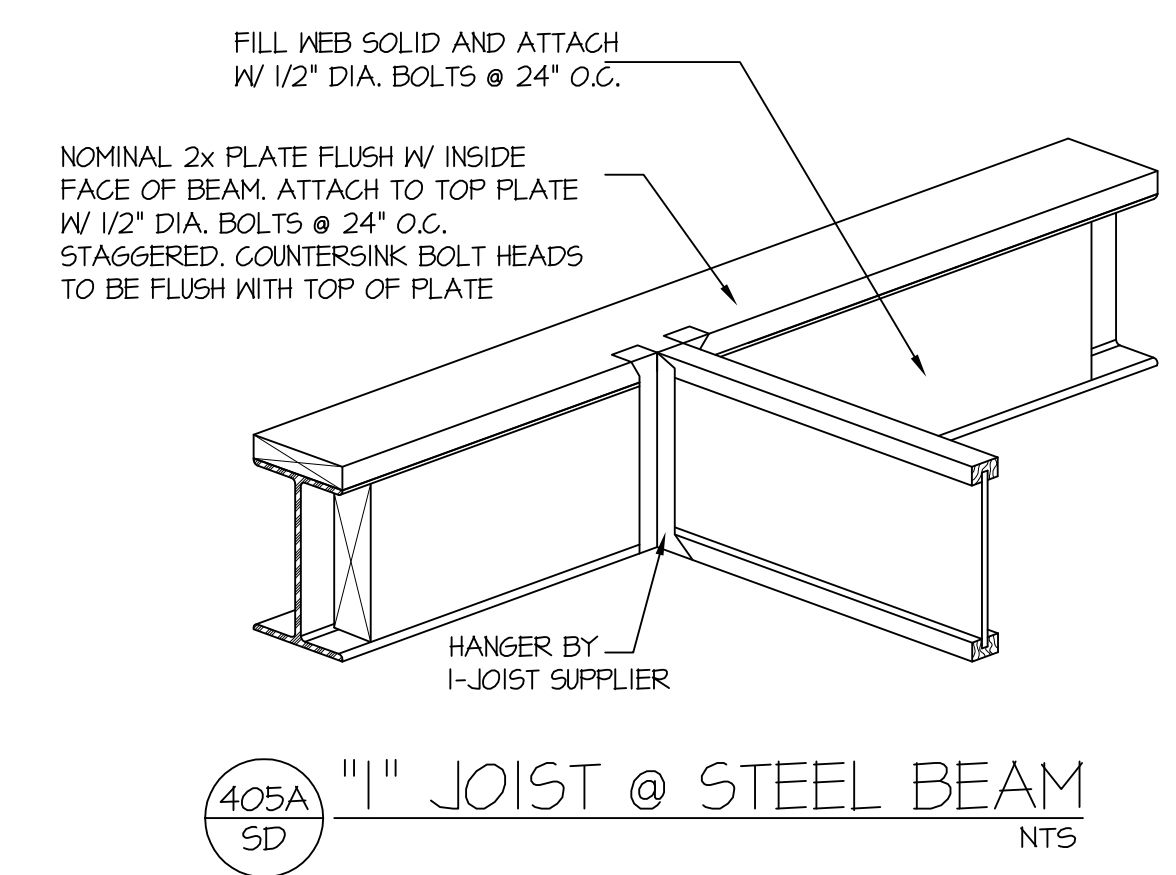
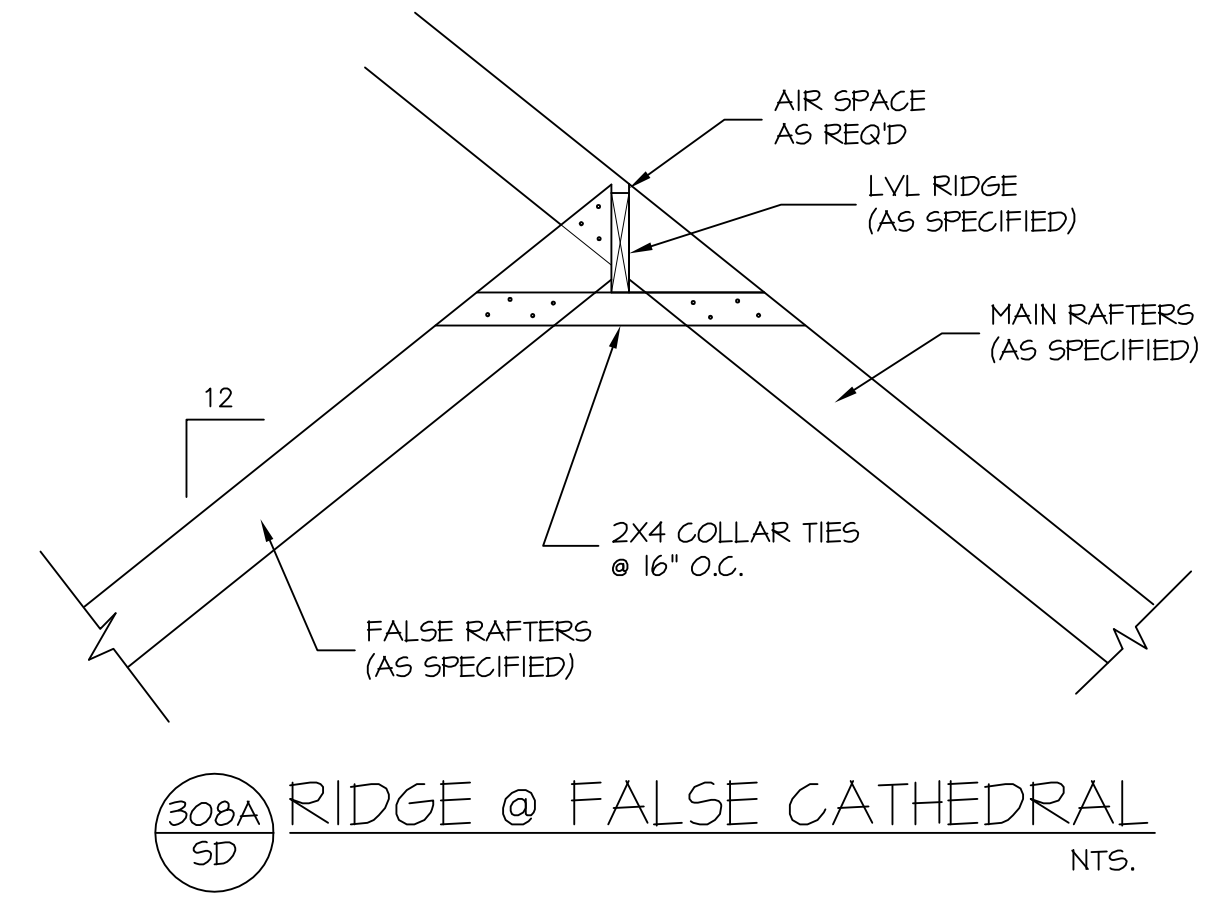
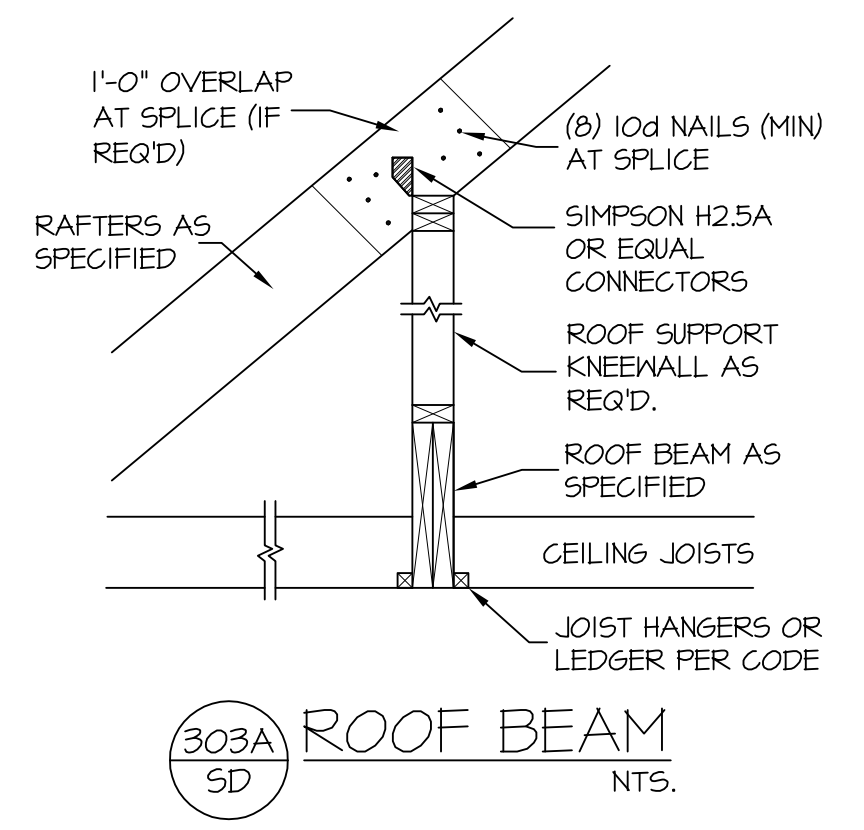
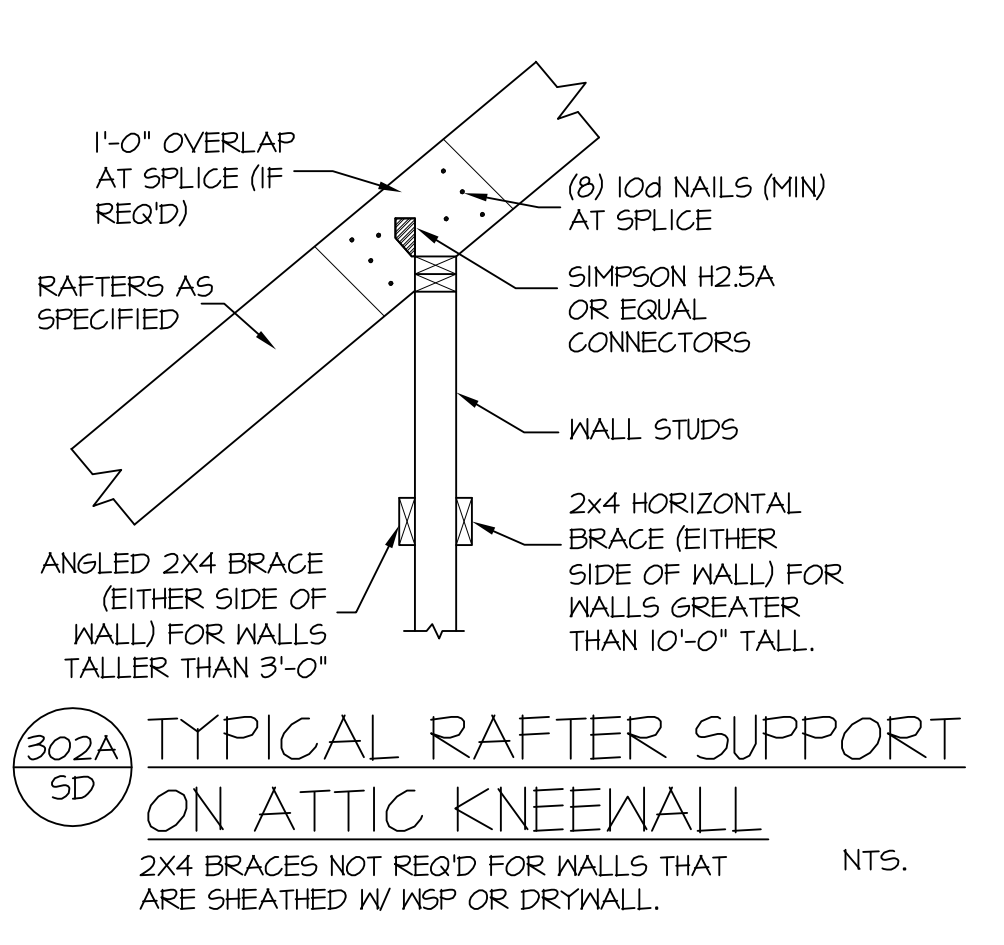
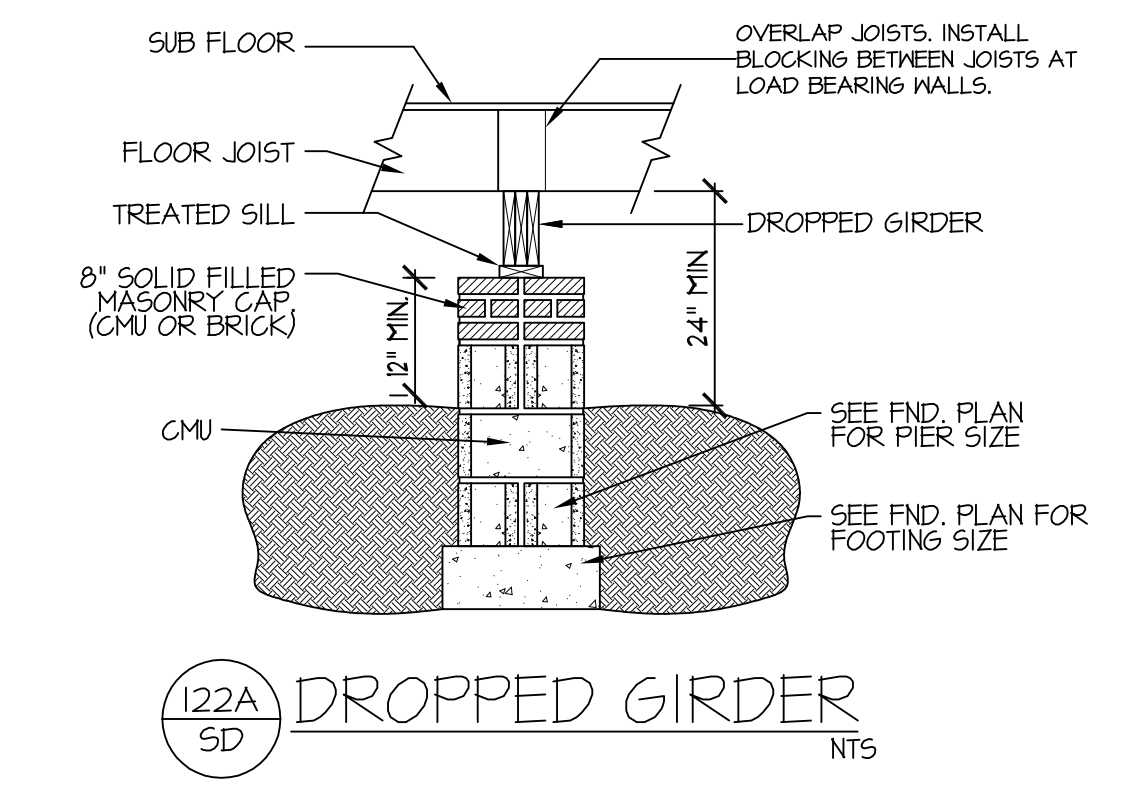
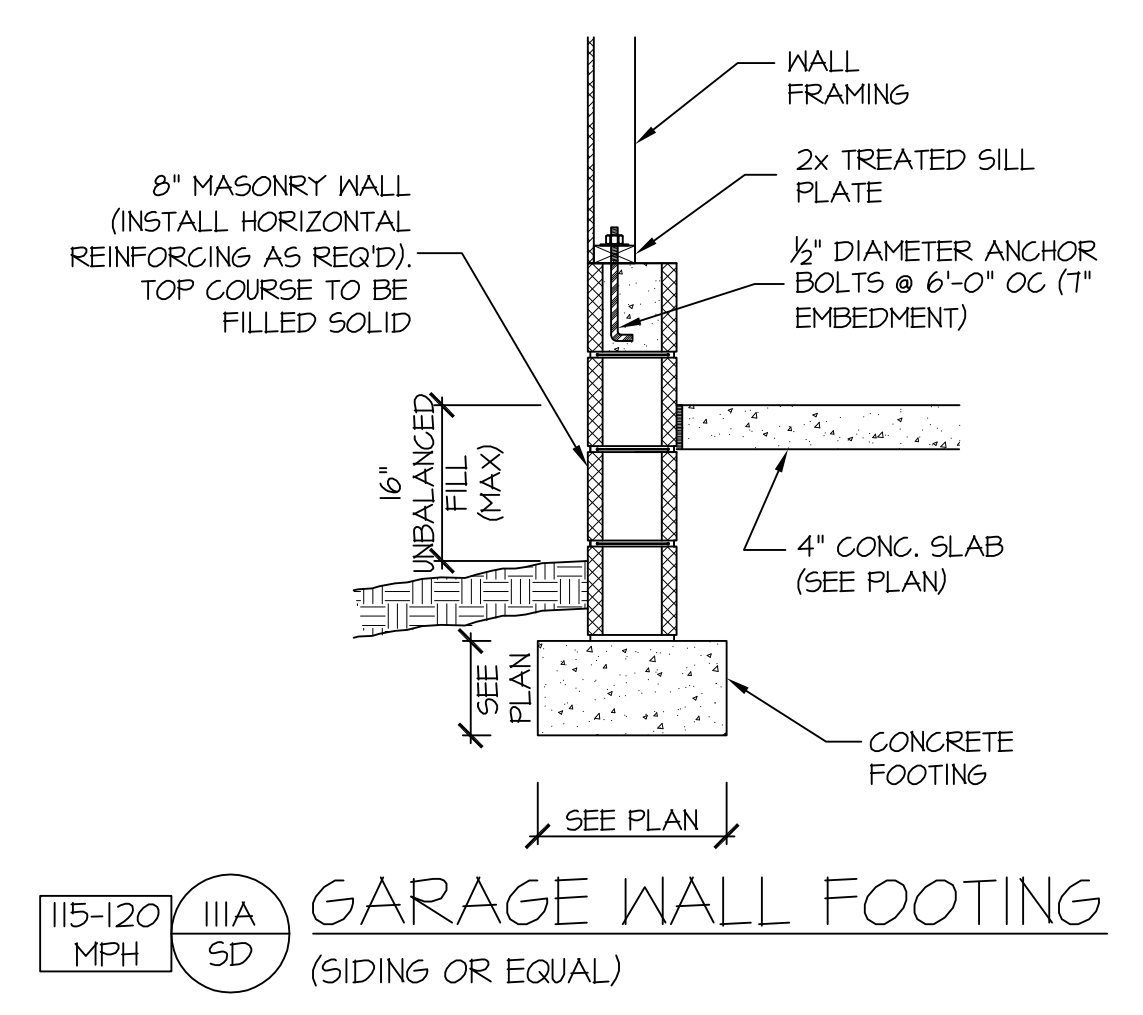
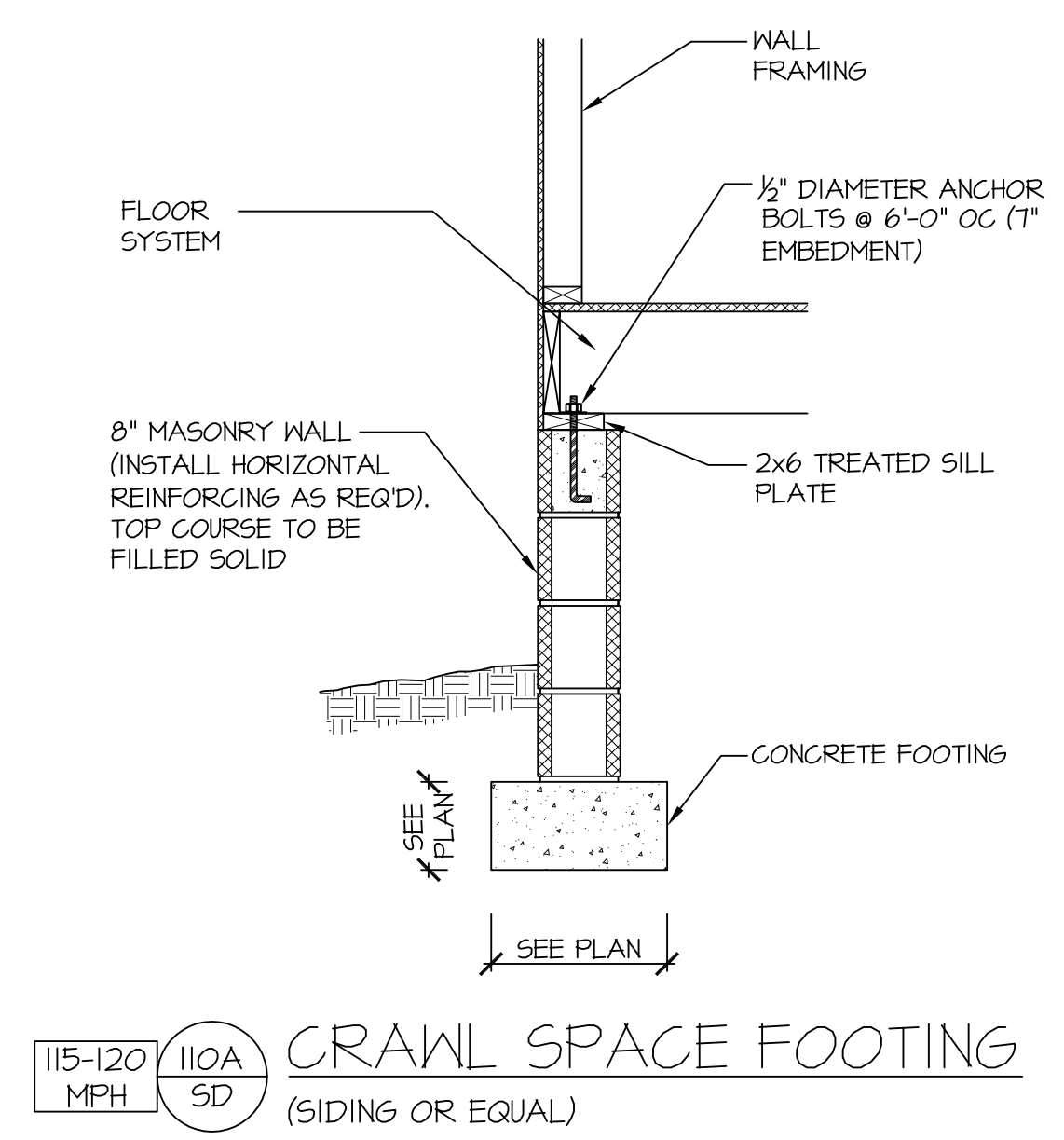
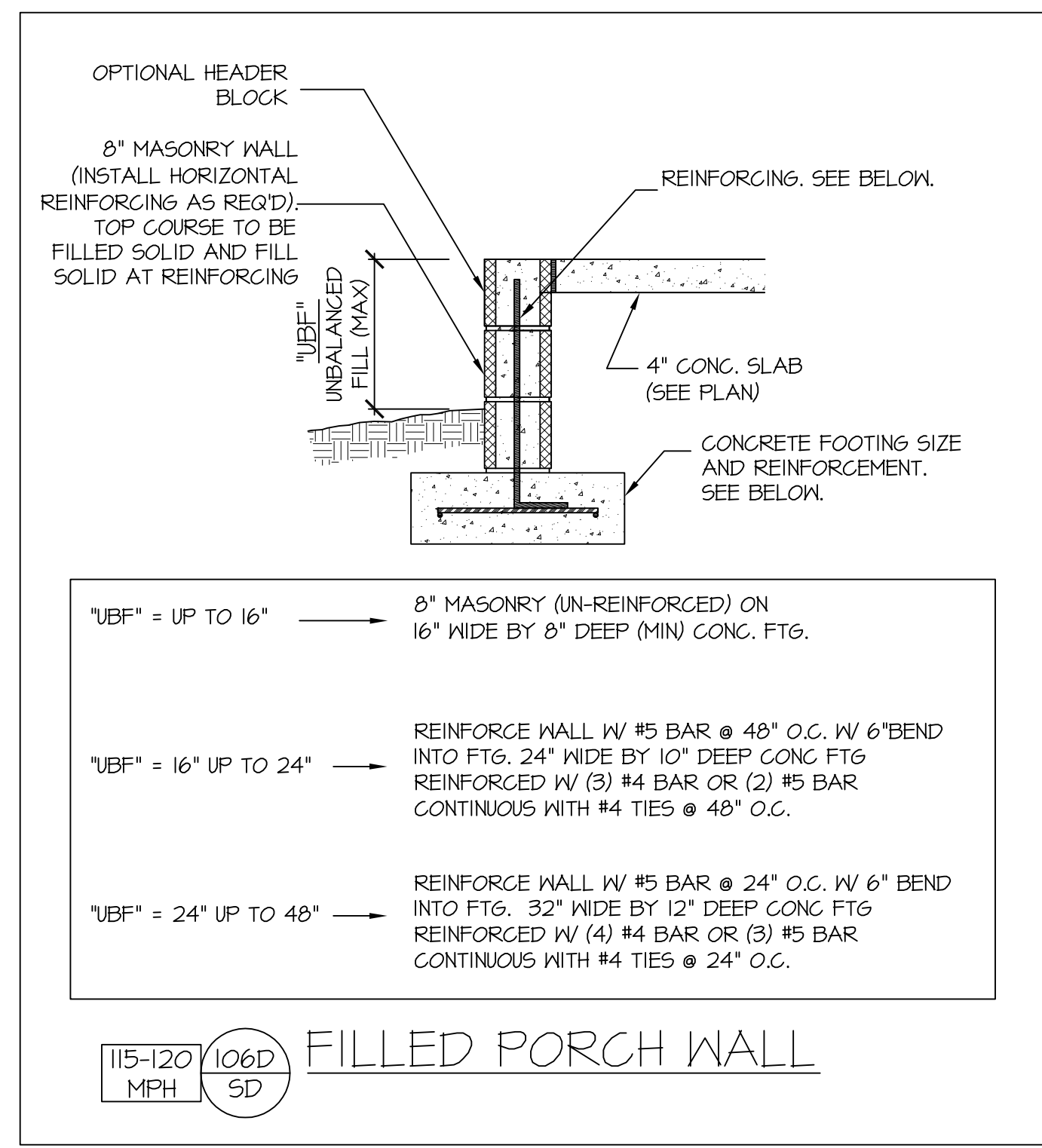
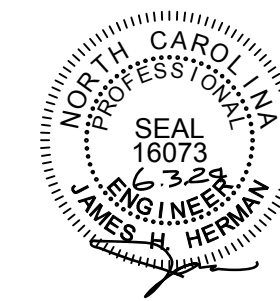

Engineers seal applies only to structural components on this document.  
Seal does not include construction means, methods, techniques, sequences, procedures or safety precautions.  
Any deviations or discrepancies on plans are to be brought to the immediate attention of Southern Engineers. Failure to do so will void Southern Engineer's liability.  
Seal is valid for projects permitted one year from date of seal.  
Use of these plans constitutes approval of terms & conditions as defined in the customer agreement.

**Southern Engineers, P.A.**  
3716 Benson Drive, Raleigh, NC 27609  
Phone: (919) 878-1617  
License: C-4772  
www.southernengineers.com

**DYNAMIC DESIGN GROUP**

**Lot 51, Cotton Farms**  
"Lavore"  
**KEN HARVEY HOMES**

**SD**

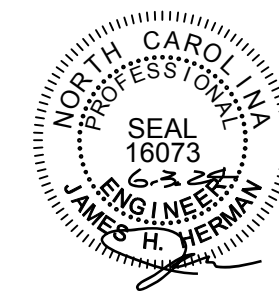

PROJECT #  
24-1493

Engineers seal applies only to structural components on this document.  
Seal does not include construction means, methods, techniques, sequences, procedures or safety precautions.  
Any deviations or discrepancies on plans are to be brought to the immediate attention of Southern Engineers. Failure to do so will void Southern Engineer's liability.  
Seal is valid for projects permitted one year from date of seal.  
Use of these plans constitutes approval of terms & conditions as defined in the customer agreement.

**Southern Engineers, P.A.**  
3716 Benson Drive, Raleigh, NC 27609  
Phone: (919) 878-1617  
License: C-4772  
www.southernengineers.com

**DYNAMIC  
DESIGN  
GROUP**

**Lot 51, Cotton Farms  
"Lavoré"  
KEN HARVEY HOMES**

**SD**

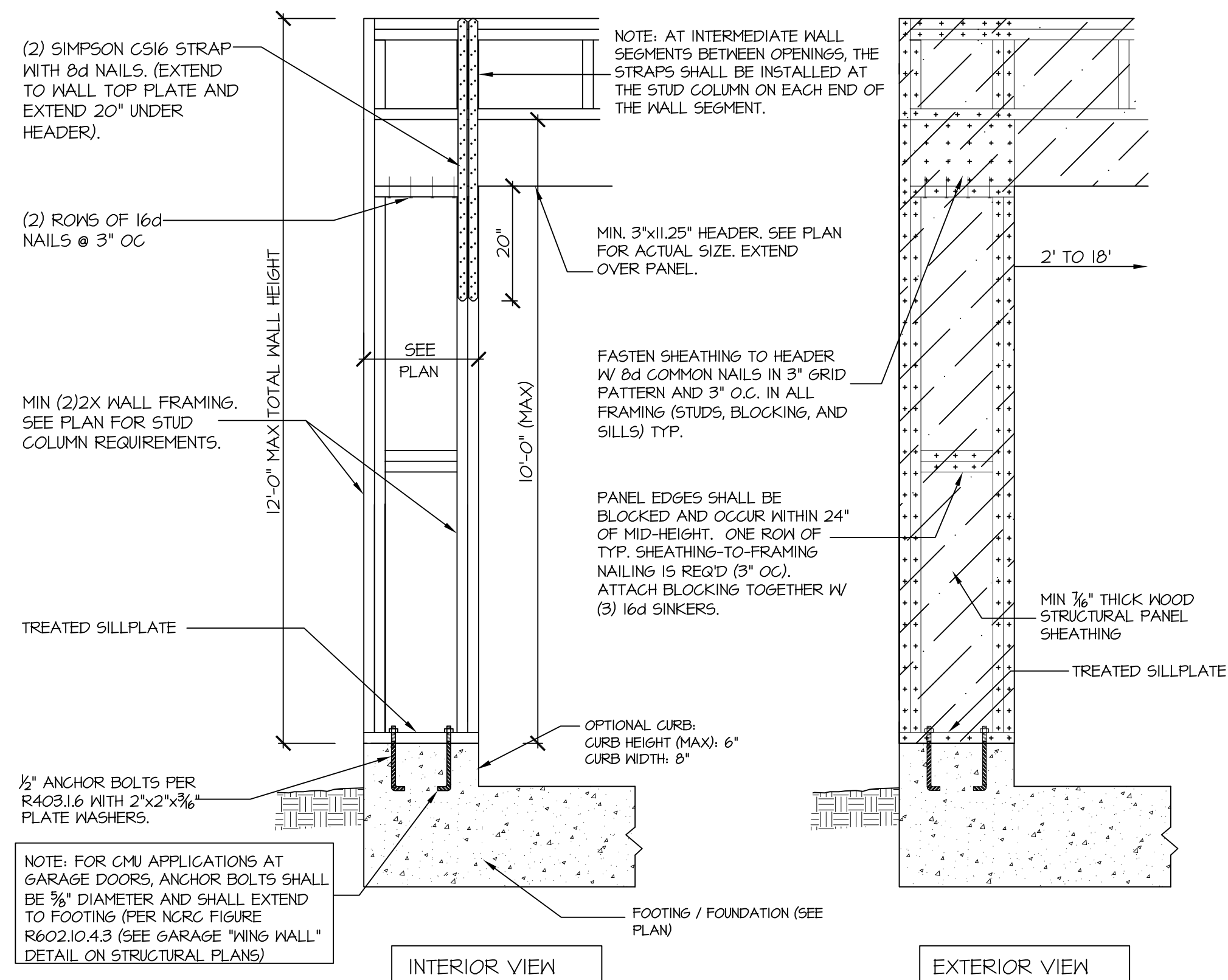

905B SD CS-PF: CONTINUOUS PORTAL FRAME CONSTRUCTION  
DETAIL AND APPLICATION BASED ON NCRG FIGURE R602.10.1 - PORTAL FRAME CONSTRUCTION

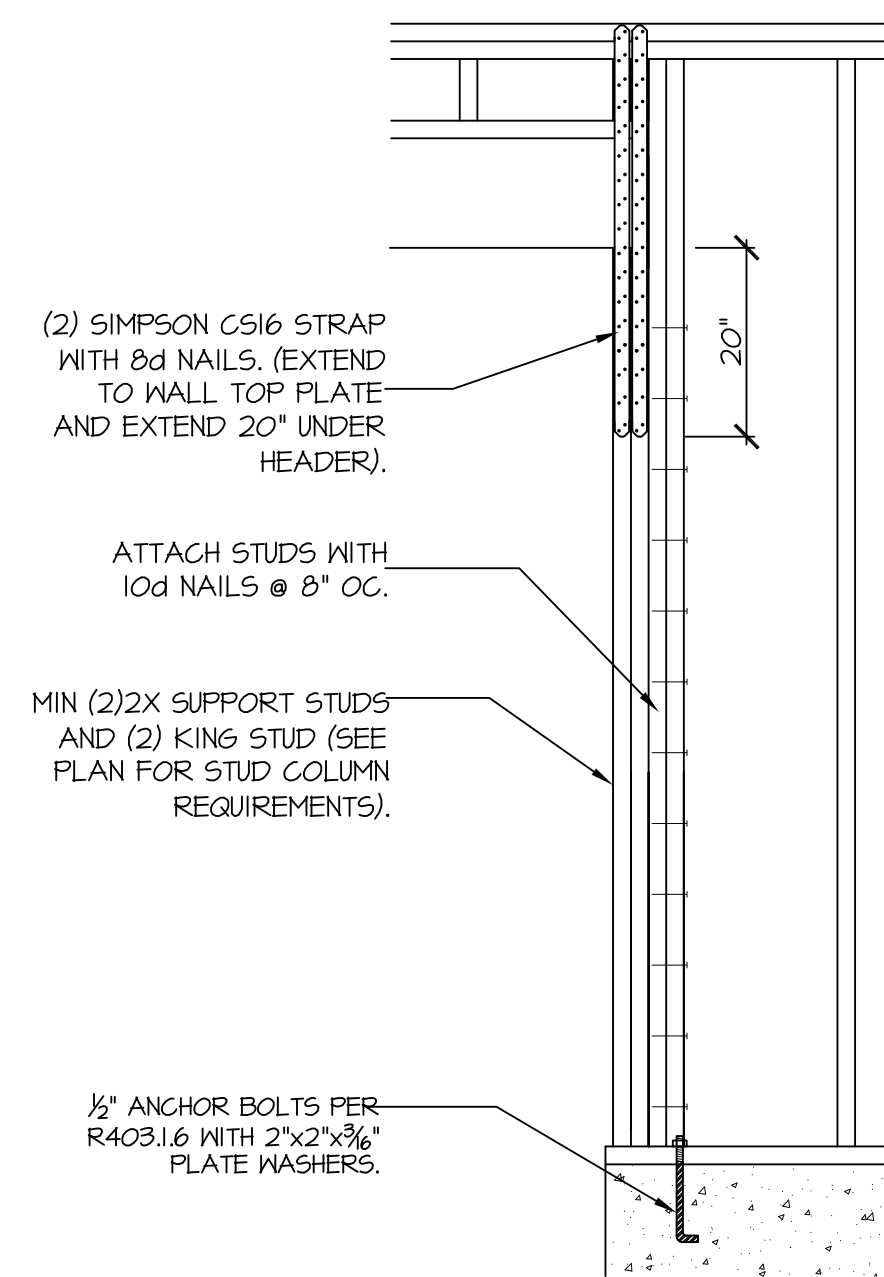

906 SD CS-PF: END CONDITION DETAIL  
(FOR USE WITH SINGLE CS-PF CONDITION)  
DETAIL AND APPLICATION BASED ON NCRG FIGURE R602.10.1 - PORTAL FRAME CONSTRUCTION

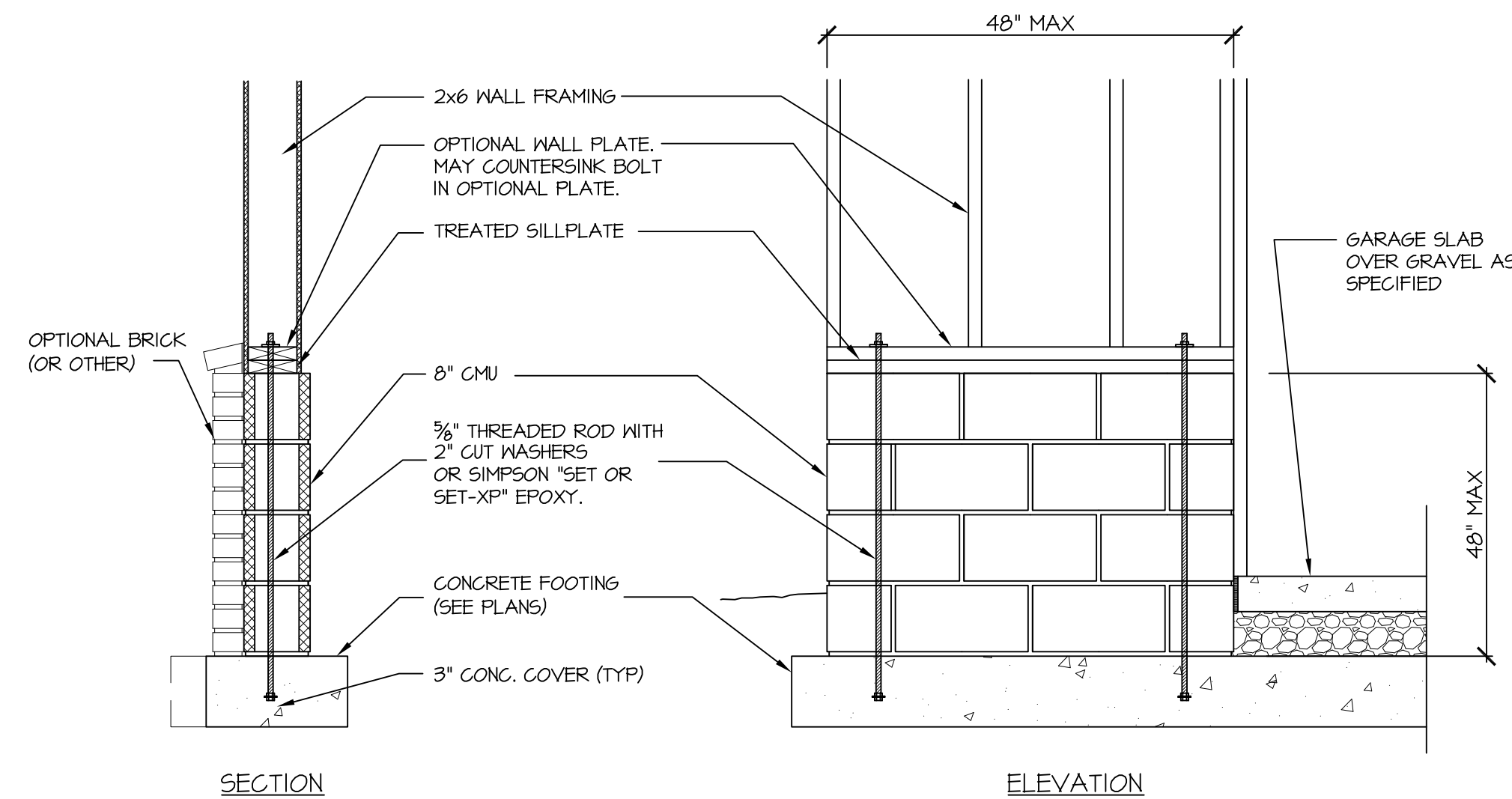

907 SD GARAGE 'WING WALL' REINFORCING  
PER IRC FIGURE R602.10.4.3

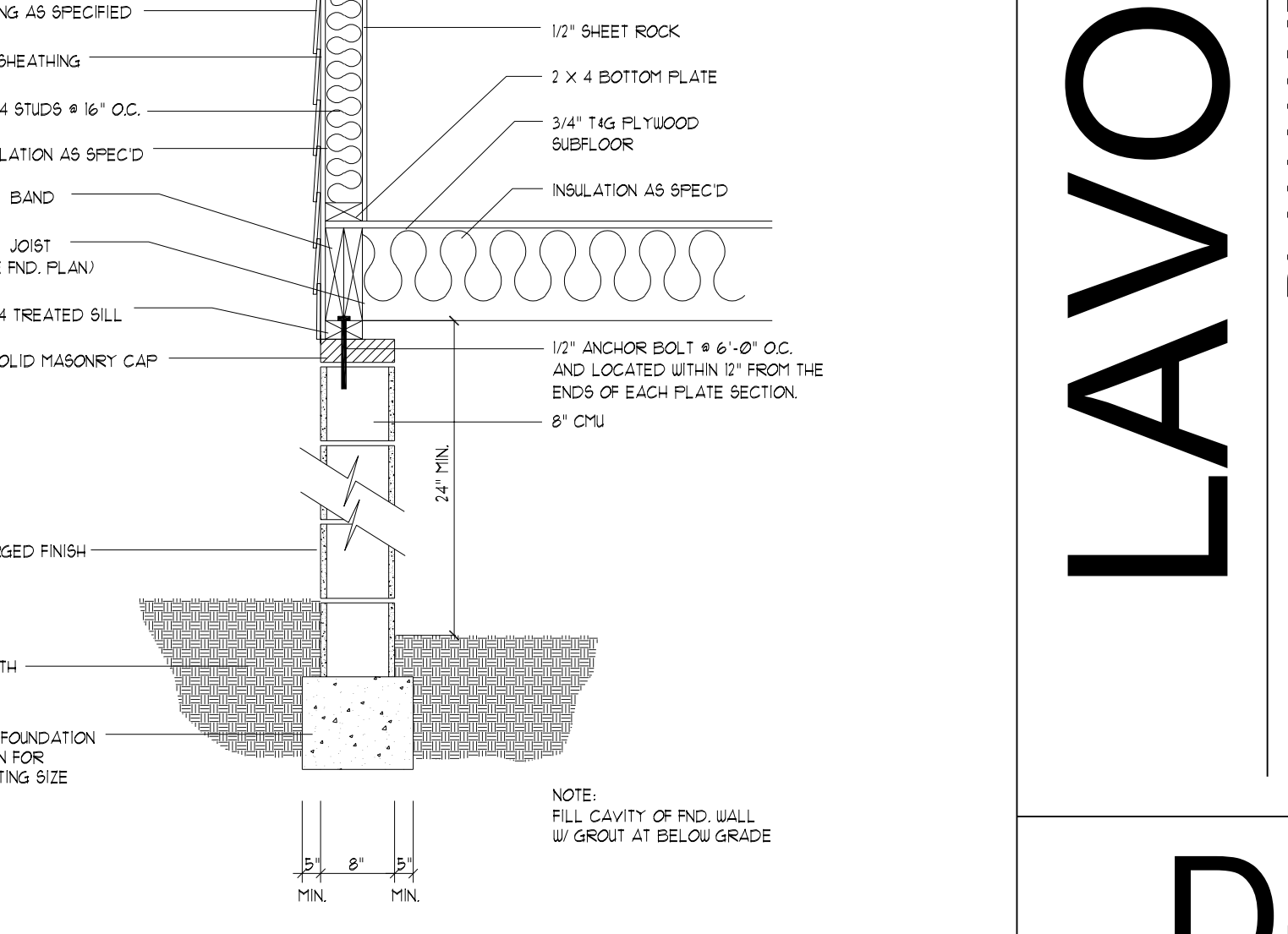
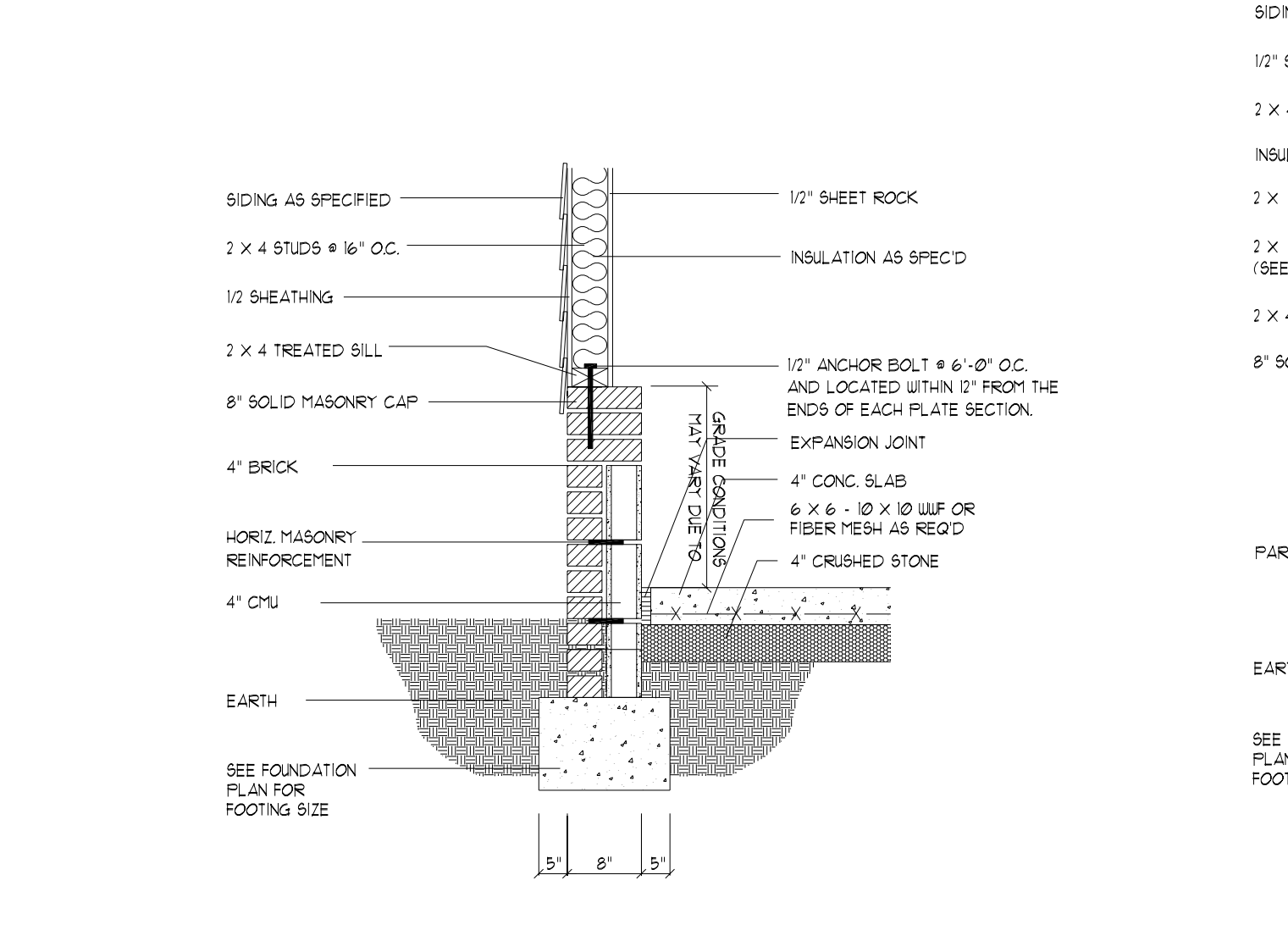
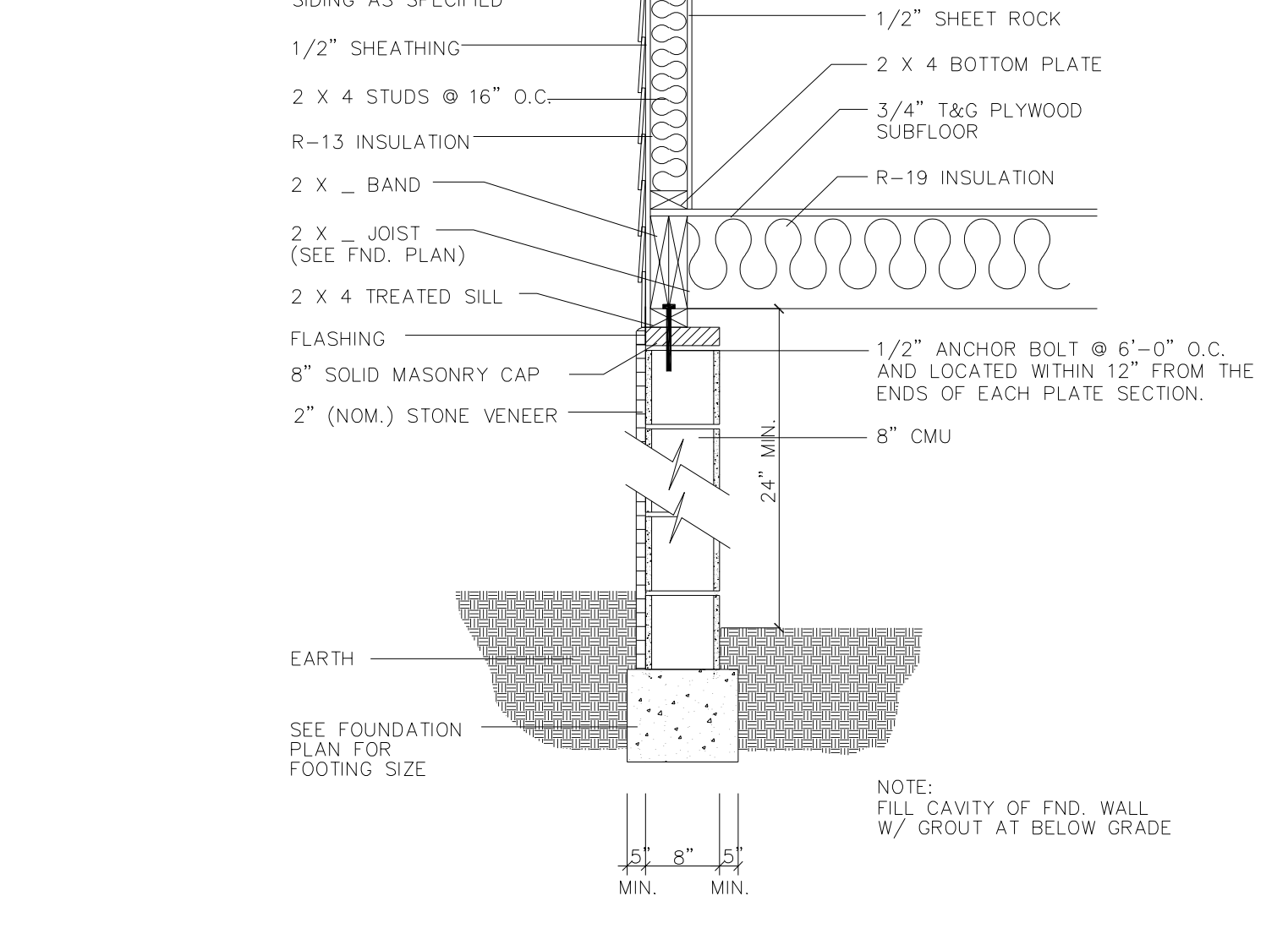
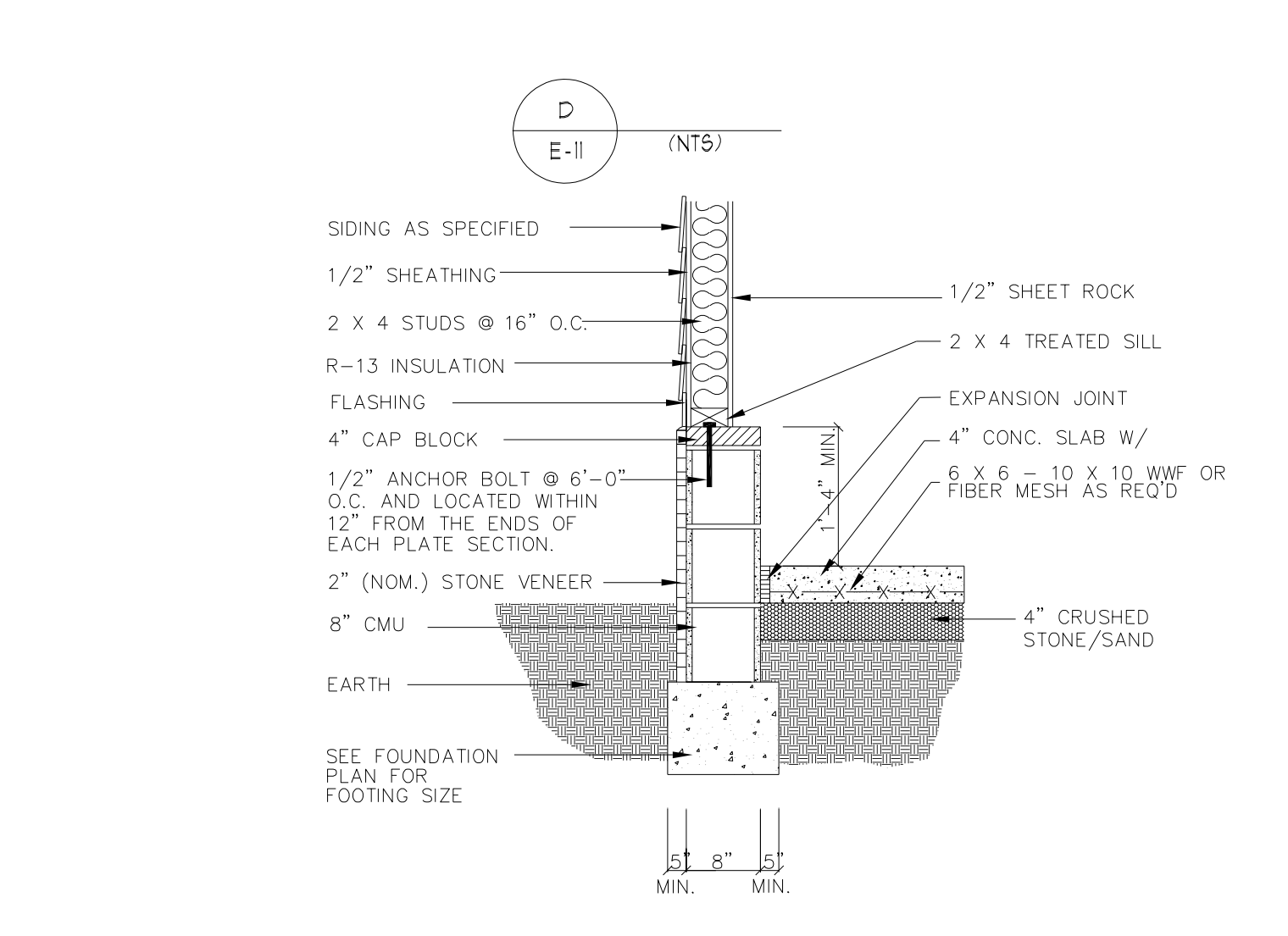
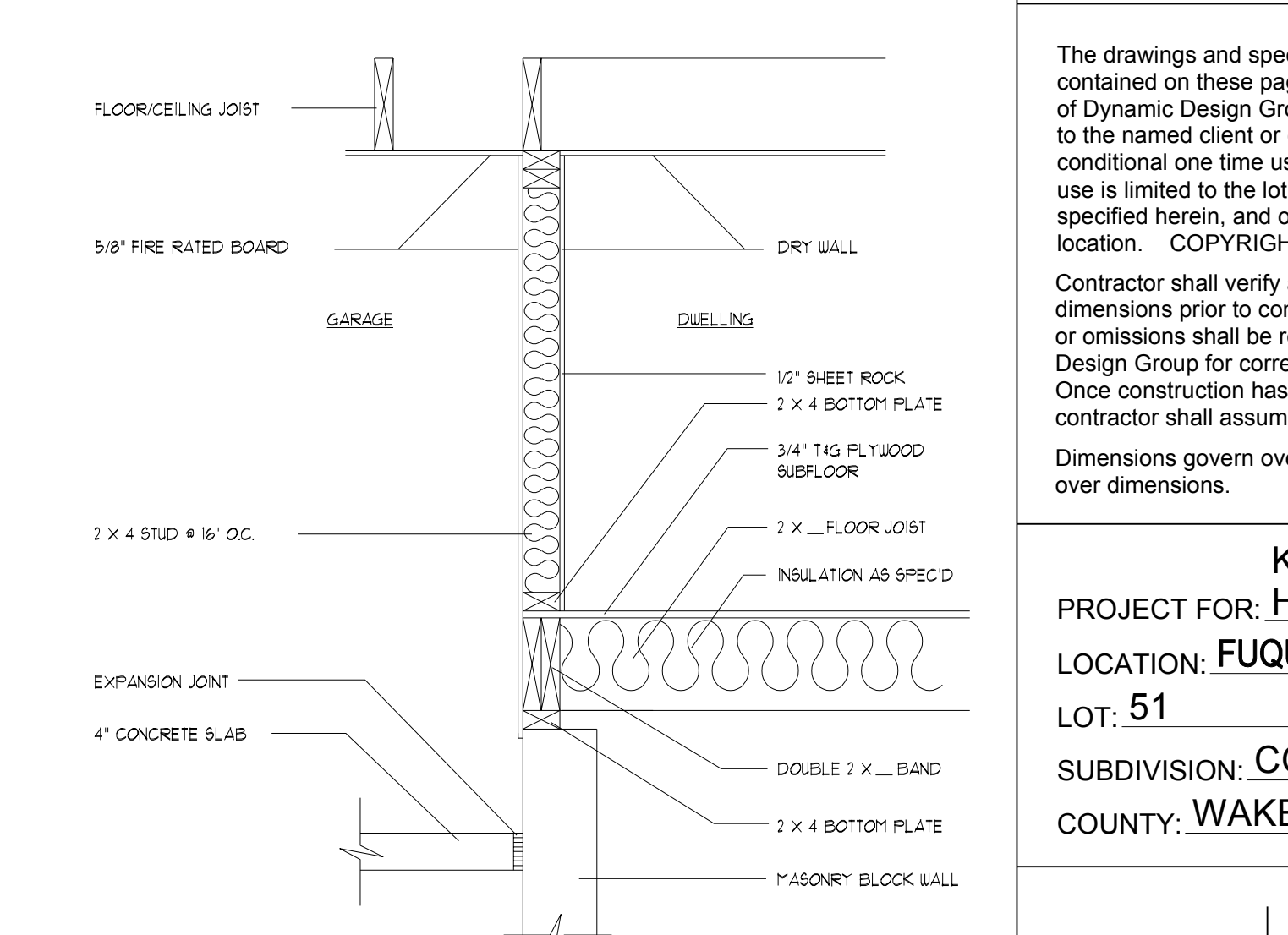
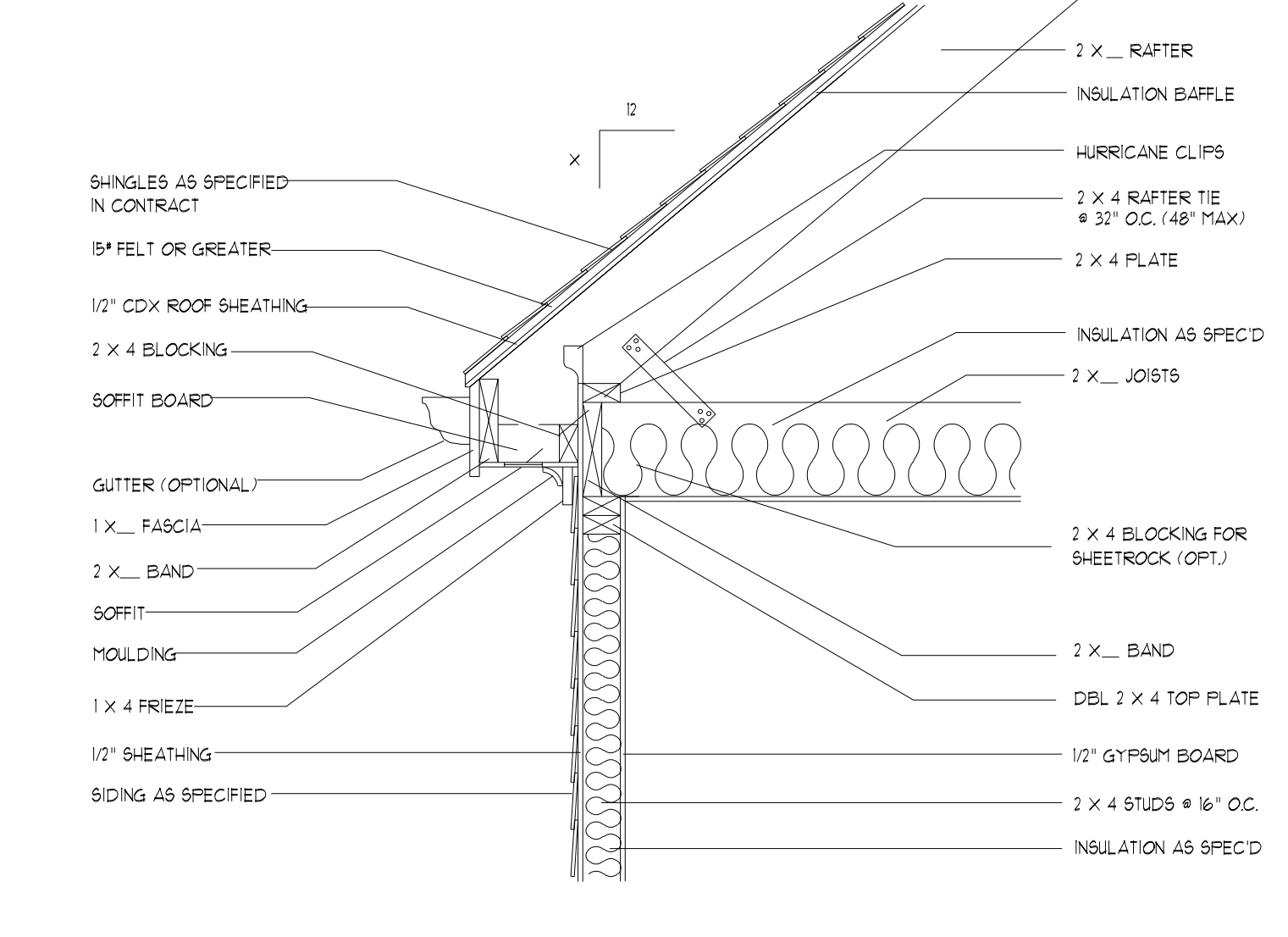
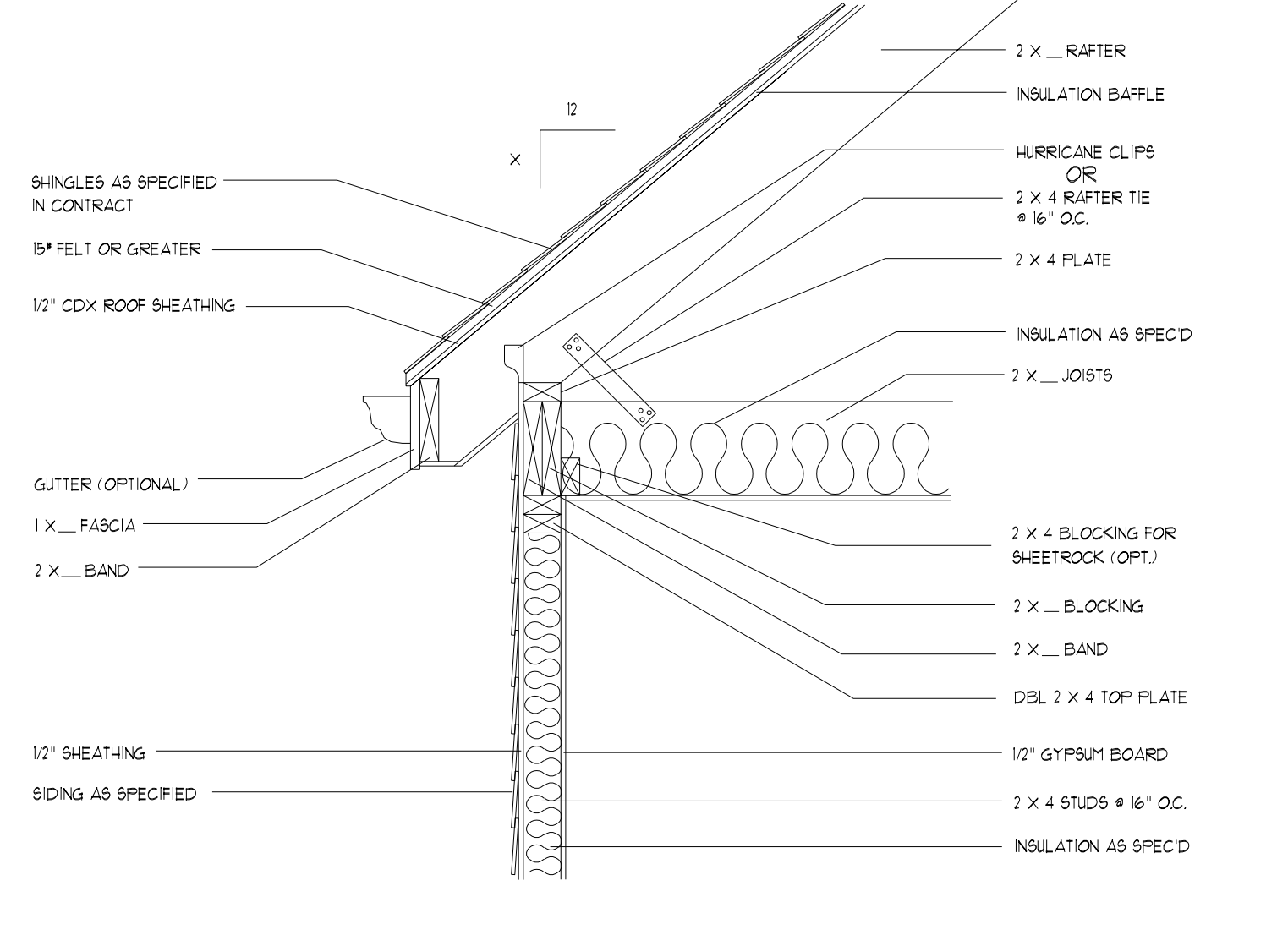
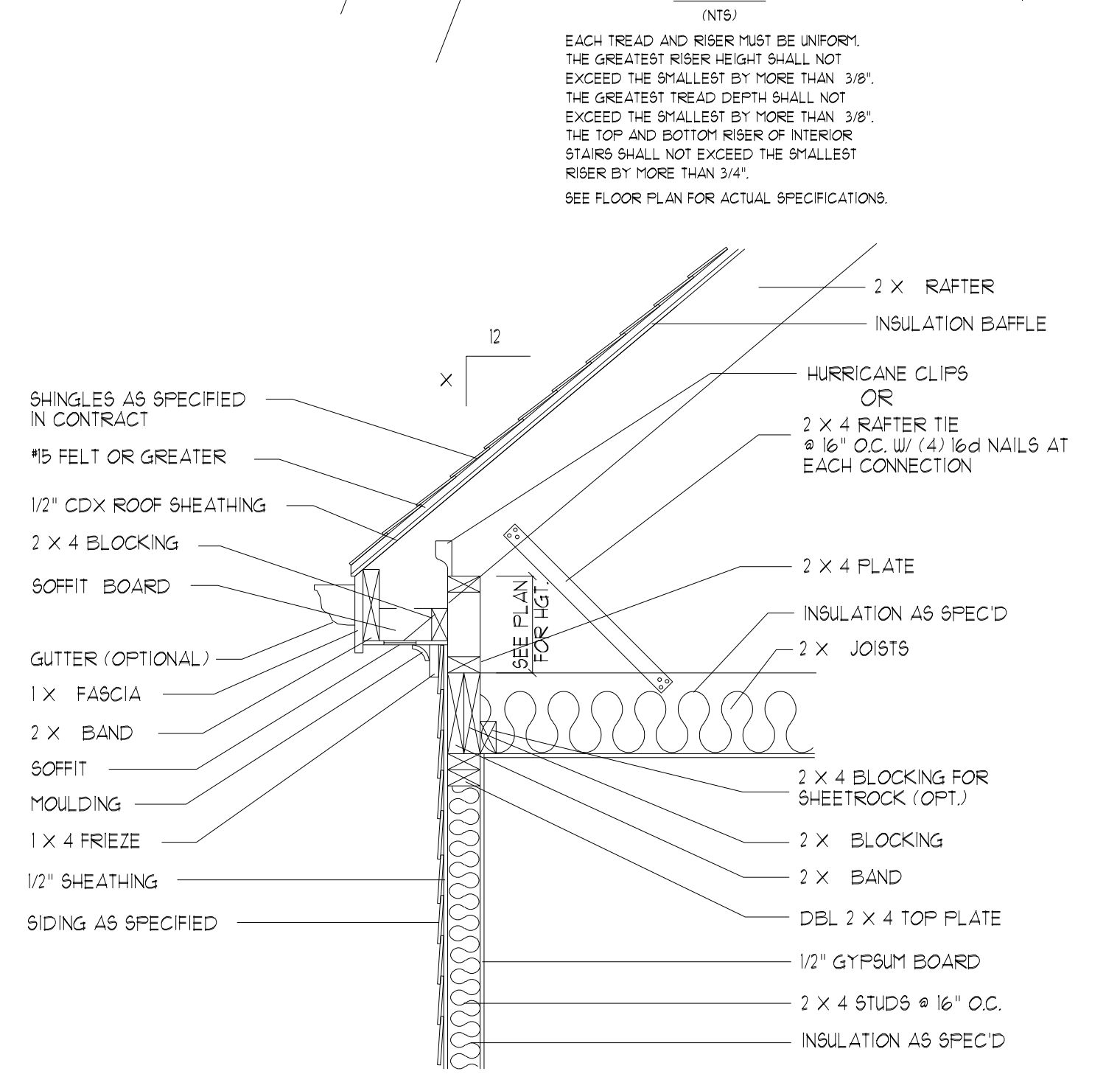
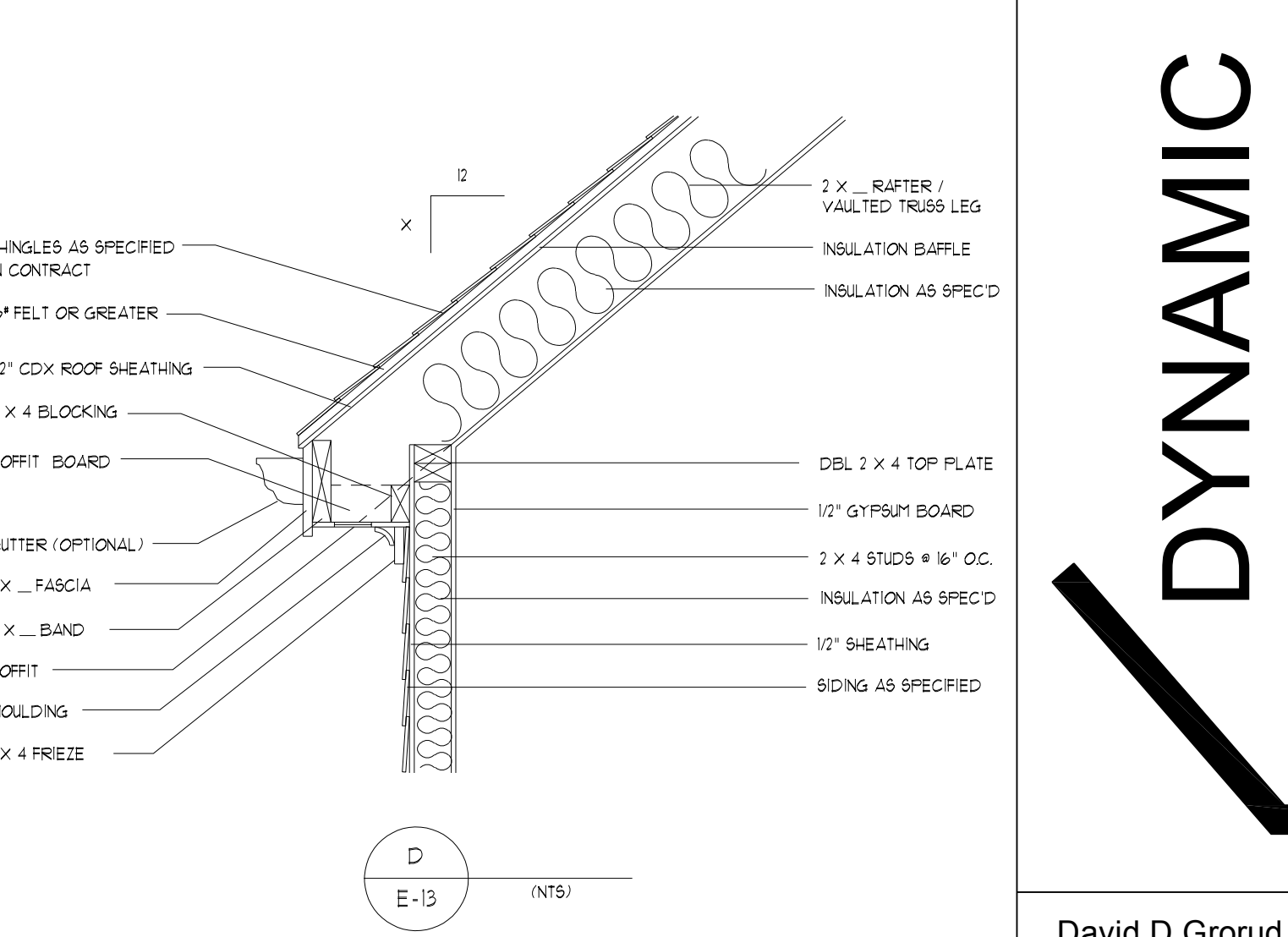
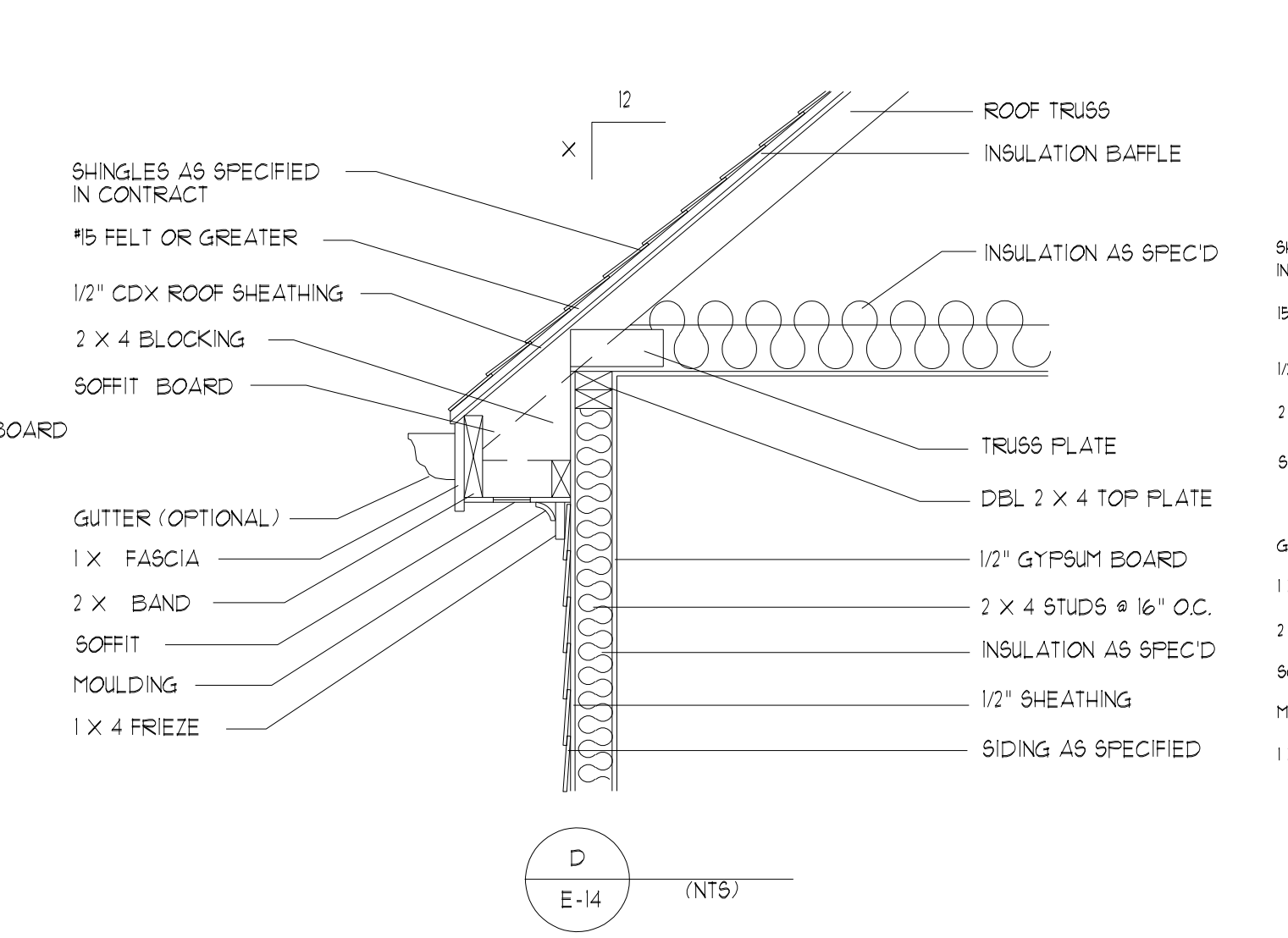
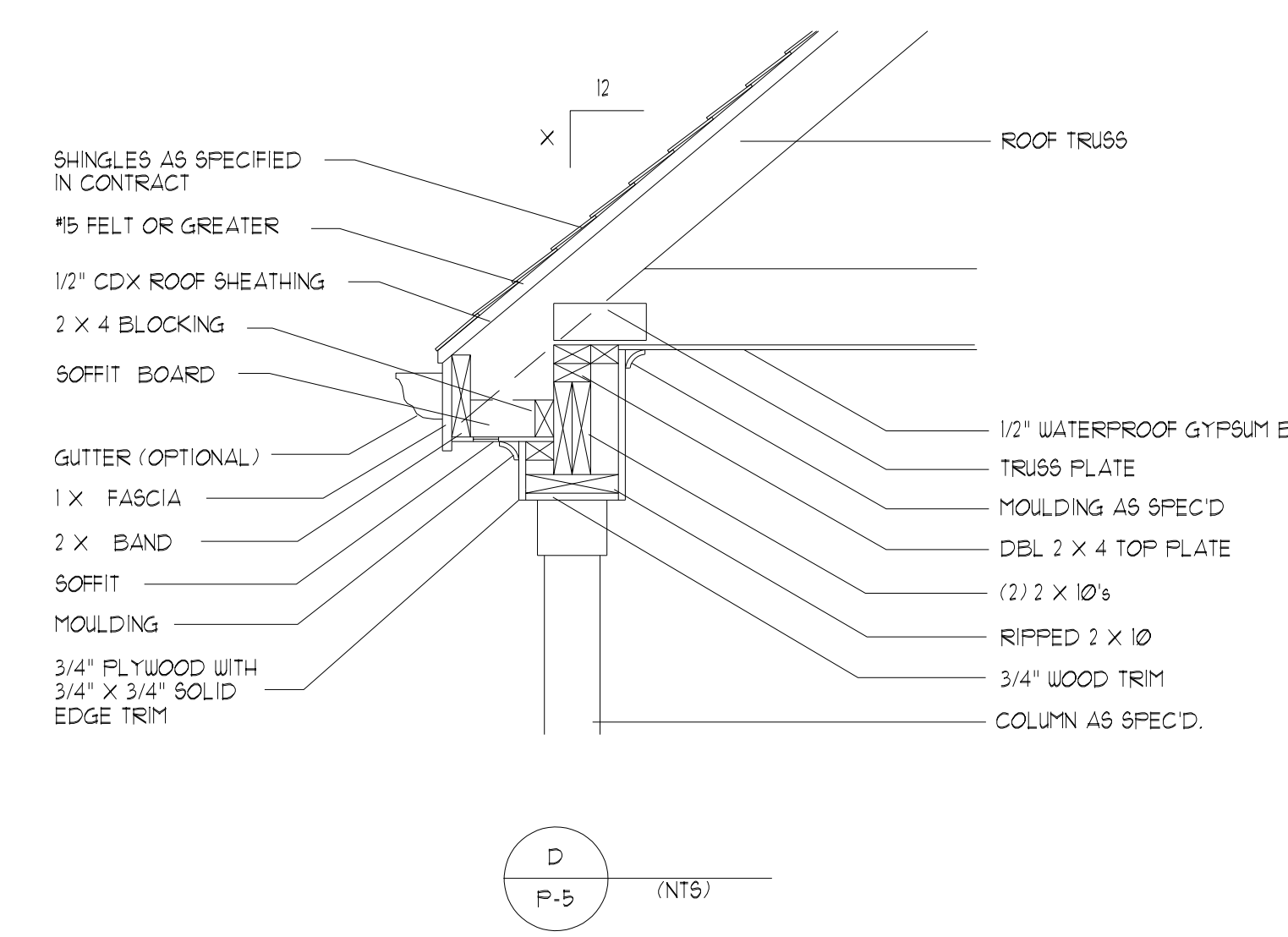
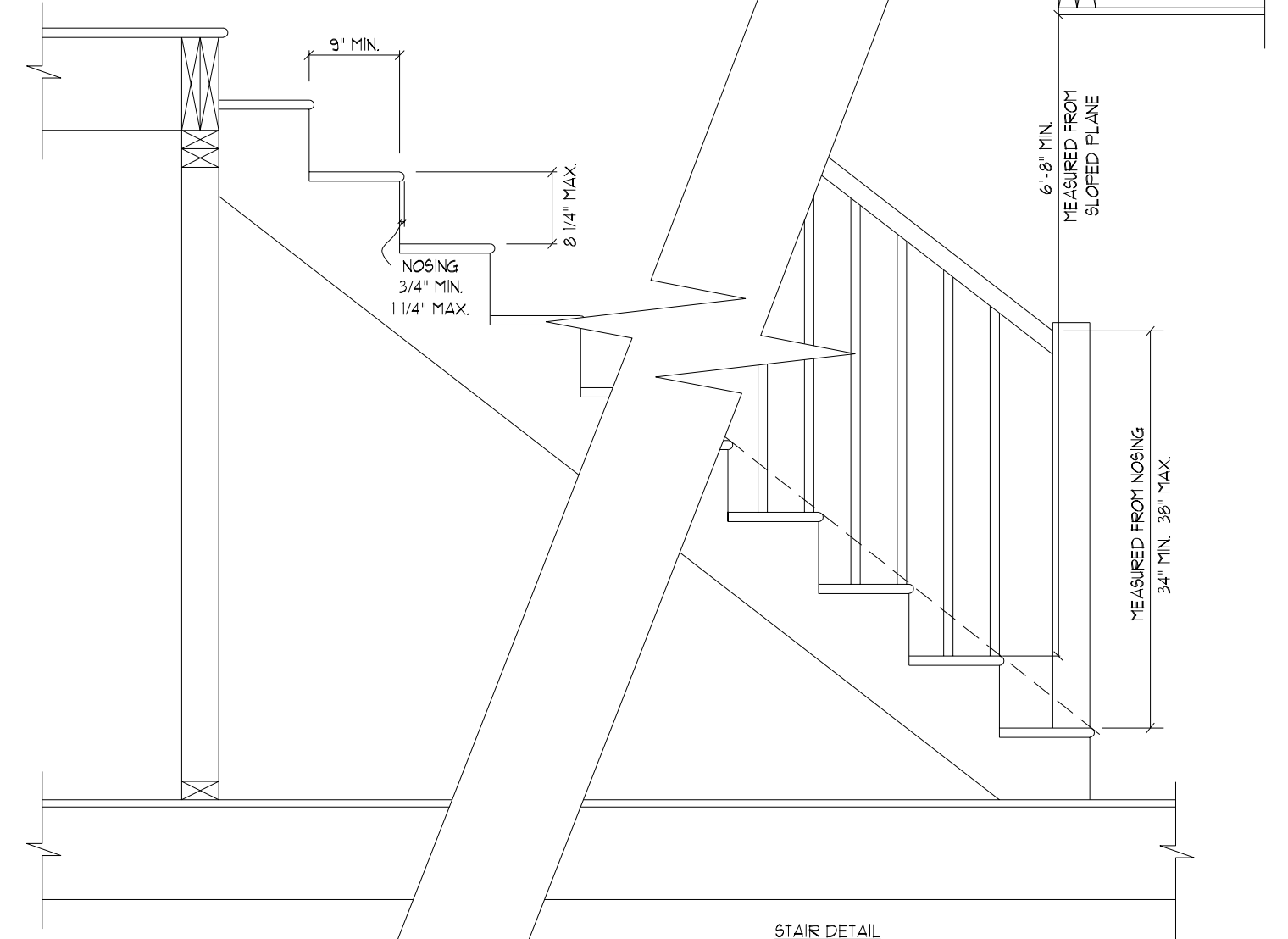

David D Grurd  
 (919) 601-1406  
 DynamicDesignGroup@gmail.com  
 www.DynamicDesignGroupInc.com

The drawings and specifications (plans) contained on these pages are the property of Dynamic Design Group and are offered to the named client or contractor for a conditional one time use. The conditional use is limited to the lot and subdivision specified herein, and only for said location. COPYRIGHT 2024  
 Contractor shall verify all conditions and dimensions prior to construction. Any error or omissions shall be reported to Dynamic Design Group for corrections or justification. Once construction has commenced, the contractor shall assume all responsibility. Dimensions govern over scale, code governs over dimensions.

**KEN HARVEY HOMES**  
 PROJECT FOR:  
 LOCATION: **FUQUAY VARINA, NC**  
 LOT: **51**  
 SUBDIVISION: **COTTON FARMS**  
 COUNTY: **WAKE**

**LAVORE**  
 PLAN NAME  
**A1-3283-81GR**  
 PLAN I.D.  
**5.8.24**  
 DATE