



Boise Cascade
www.bldr.com

1135 ROBESON STREET
FAYETTEVILLE, NC 28305
V (910) 485-1111

7601 BOEING DRIVE
GREENSBORO, NC 27409
V (336) 884-5454

3189 NC HIGHWAY 5
ABERDEEN NC 28315
V (910) 944-2516

This layout and associated materials list has been prepared based on project plans and/or information provided to Builders FirstSource (BFS). It remains the responsibility of the builder, architect, designer, or other responsible persons to review this information to assure that it is appropriate, accurate, complete and complies with applicable building codes.

- GENERAL NOTES:**
- 1.) READ THE INSTALLATION GUIDE BEFORE FRAMING.
 - 2.) ALL WALLS SHOWN ARE LOAD BEARING UNLESS NOTED OTHERWISE. WALLS NOT SHOWN ARE CONSIDERED NON-LOAD BEARING.
 - 3.) UNLESS STATED OTHERWISE ALL CEILING & ROOF LOADS BRACE DIRECTLY TO LOAD BEARING WALLS SUPPORTED BY FOUNDATION.
 - 4.) CONTACT BUILDERS FIRSTSOURCE BEFORE MAKING ANY ALTERATIONS OR ADJUSTMENTS...FAILURE TO DO SO MAY RESULT IN COSTLY REPAIRS.

STOUT BONNET

2ND FLOOR PLACEMENT PLAN

Builders FirstSource, Central Carolina Markets

DRAWN BY: Vernon Schmidt

SCALE: NTS

DATE: 6/13/2024

JOB NUMBER: 4083555

MINIMUM DESIGN DATA

LIVE LOAD 40 PSF
DEAD LOAD 10 PSF

TOTAL LOAD 50 PSF

DOL = 100%

DEFLECTION CRITERIA
L/480 (MINIMUM)

ARCHITECTURAL PLAN DATE
xx-xx-xxxx

REVISED ARCH. PLAN DATE
xx-xx-xx

SD3132024

Sheet
1 of 1

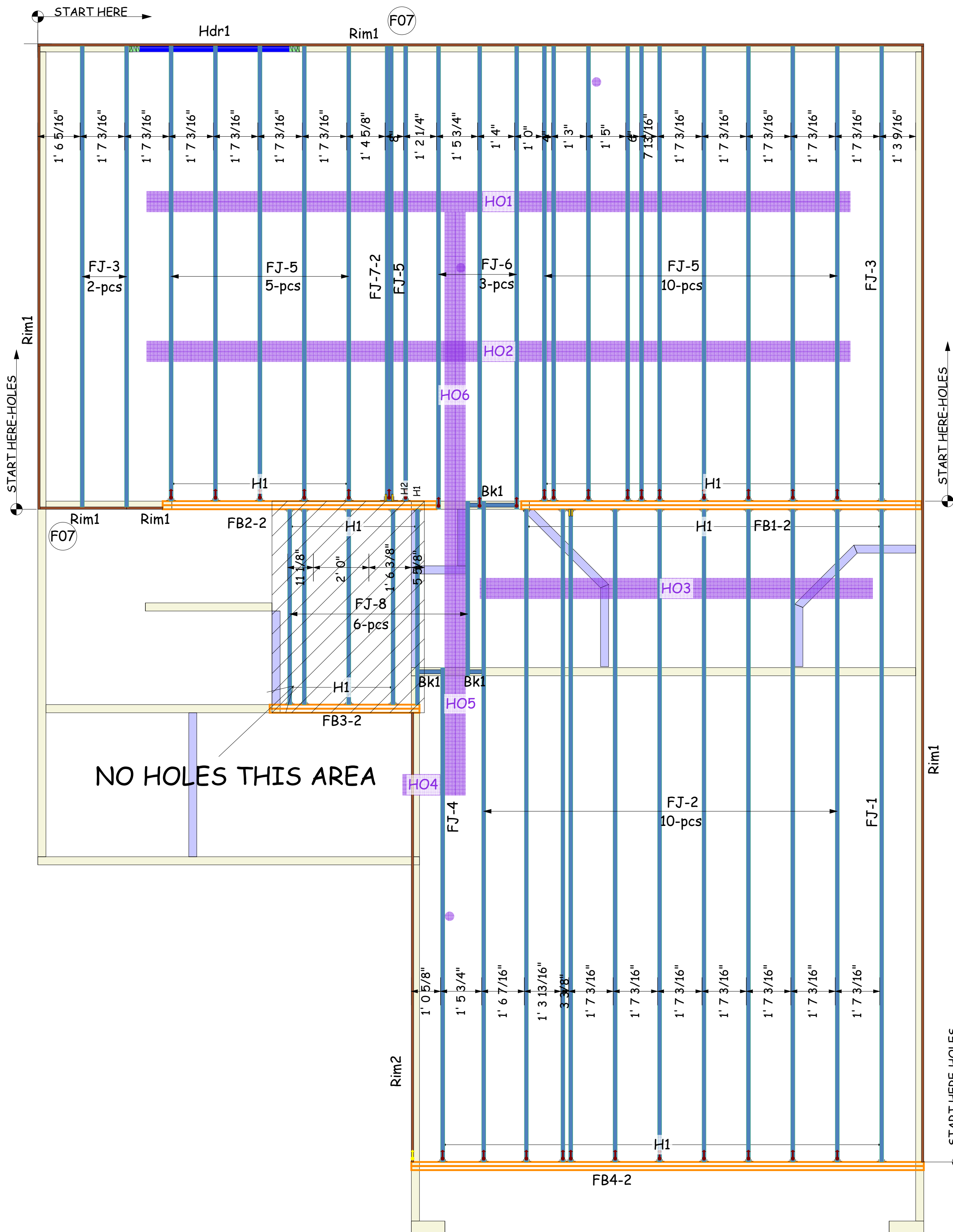
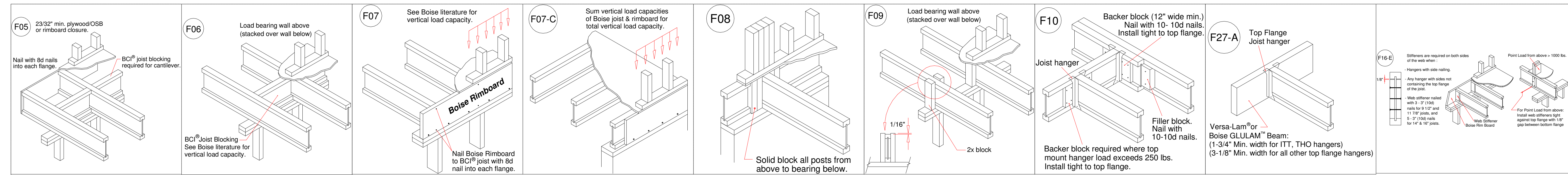

Products				
PlotID	Length	Product	Plies	Net Qty
FJ-1	24' 0"	14" BCI® 4500s-1.8	1	1
FJ-2	24' 0"	14" BCI® 4500s-1.8	1	10
FJ-3	18' 0"	14" BCI® 4500s-1.8	1	3
FJ-4	18' 0"	14" BCI® 4500s-1.8	1	1
FJ-5	18' 0"	14" BCI® 4500s-1.8	1	16
FJ-6	18' 0"	14" BCI® 4500s-1.8	1	3
FJ-7-2	18' 0"	14" BCI® 4500s-1.8	2	2
FJ-8	8' 0"	14" BCI® 4500s-1.8	1	6
FB1-2	16' 0"	1-3/4" x 14" VERSA-LAM® LVL 2.1E 3100 SP	2	2
FB2-2	10' 0"	1-3/4" x 14" VERSA-LAM® LVL 2.1E 3100 SP	2	2
FB3-2	6' 0"	1-3/4" x 14" VERSA-LAM® LVL 2.1E 3100 SP	2	2
FB4-2	20' 0"	1-3/4" x 18" VERSA-LAM® LVL 2.1E 3100 SP	2	2
Rim1	12' 0"	1" x 14" BC RIM BOARD OSB	1	8
Rim2	12' 0"	1" x 14" BC RIM BOARD OSB	1	2
Bk1	3' 0"	14" BCI® 4500s-1.8	1	1

Wall Framing				
PlotID	Length	Product	Plies	Net Qty
Hdr1	6' 0"	1-3/4" x 9-1/4" VERSA-LAM® LVL 2.1E 3100 SP	2	2

Accessories				
PlotID	Length	Product	Plies	Net Qty
Web Stiffeners (14" BCI® 4500s-1.8)				
			1	4

Hangers				
PlotID	Qty	Manuf	Product	
H1	48	Simpson	IUS1.81/14	
H2	1	Simpson	MIU3.56/14	

Hole Schedule							
Member	Net Qty	Obstruction	Shape	Width/Dia.	Height	Distance From Start	Distance From Top
FJ-2	10	HO3	Circular	9"	N/A	20' 8"	7"
FJ-4	1	HO4	Circular	9"	N/A	13' 7 1/8"	7"
FJ-5	16	HO1	Circular	9"	N/A	10' 9 1/2"	7"
		HO2	Circular	9"	N/A	5' 4 3/4"	7"
FJ-6	3	HO1	Circular	9"	N/A	11' 1"	7"
		HO2	Circular	9"	N/A	5' 8 1/4"	7"
FJ-7-2	2	HO1	Circular	9"	N/A	10' 9 1/2"	7"
		HO2	Circular	9"	N/A	5' 4 3/4"	7"
Rim2	1	HO4	Circular	9"	N/A	13' 7 1/8"	7"

Lot 1 Fairground Farms