

I, MICHAEL P. GRIFFIN, certify that under my direction and supervision this map was drawn from an actual field survey; that the error of closure of the survey as calculated by coordinates is 1: 10,000+; that the area shown hereon was calculated by coordinates.

Witness my hand and seal this 21ST day of JUNE 2024.

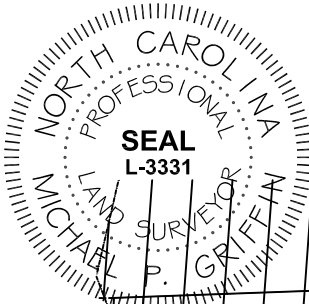

*Michael P. Griffin*

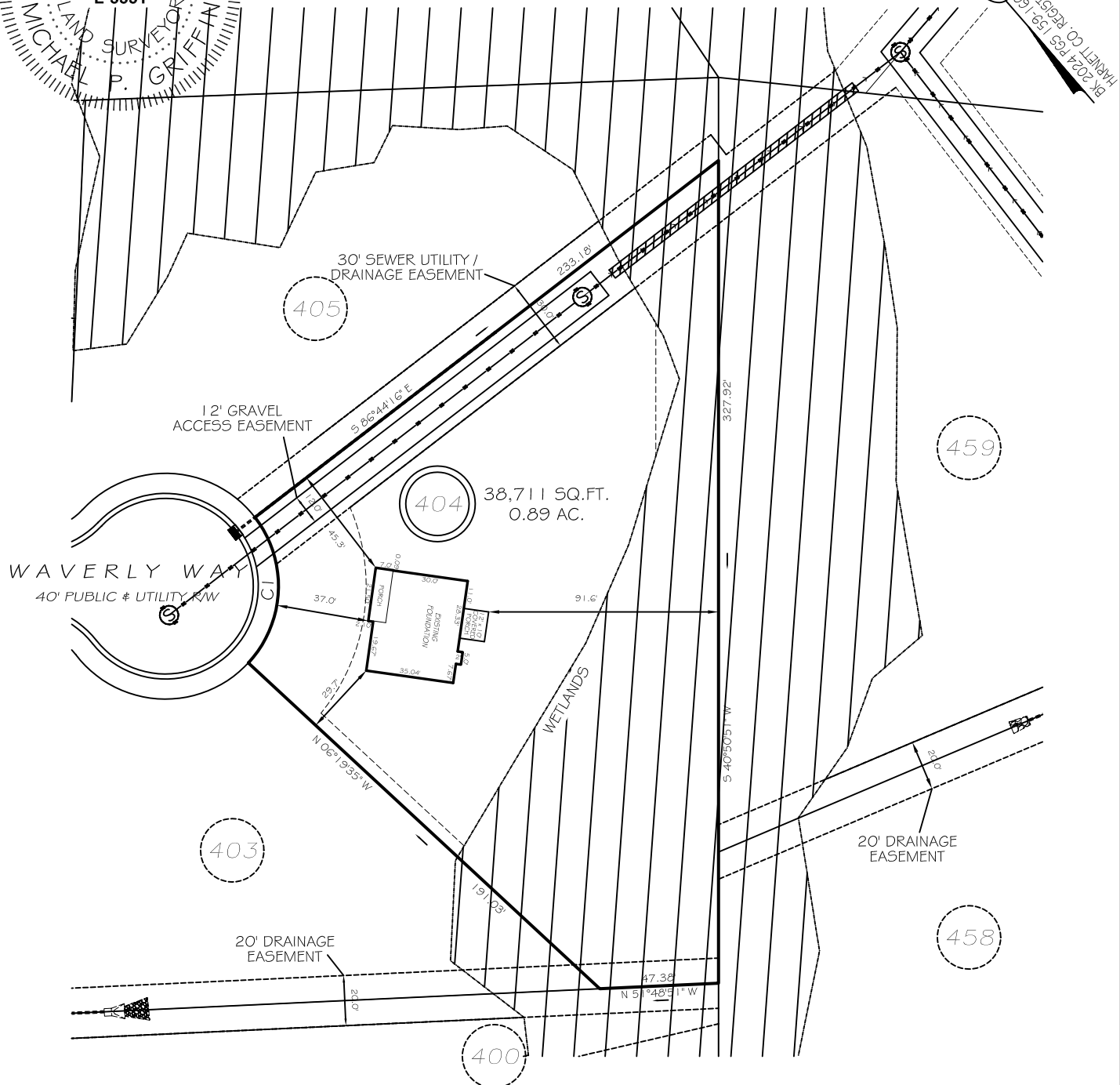
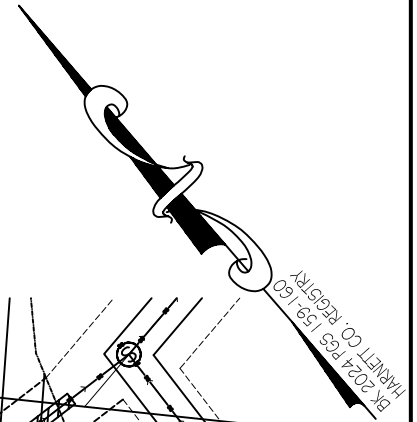

**SETBACKS**

FRONT	35'
REAR	25'
SIDE (ONE SIDE)	5'
SIDE (ONE SIDE)	10'
CORNER SIDE	20'

CI R=50.00' L=63.16' N43°28'05"E 58.10'

THIS PROPERTY IS NOT LOCATED IN THE 100 YEAR FLOOD ZONE.

**LEGEND**

EIP	EXISTING IRON PIPE	FES	FLARED END SECTION
IPS	IRON PIPE SET	WM	WATER METER
R/W	RIGHT OF WAY	CO	CLEAN OUT
N/F	NOW OR FORMERLY	FH	FIRE HYDRANT
EIS	EXISTING IRON STAKE	CB	CATCH BASIN

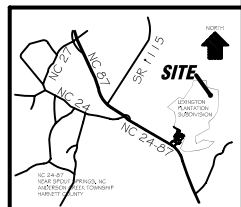

**GLS** GRIFFIN LAND SURVEYING, INC.  
 P.O. BOX 148  
 FUQUAY-VARINA, NC 27526  
 (919) 567-1963

**PLOT PLAN**  
 FOR  
**DREAM FINDERS HOMES, LLC**  
 LEXINGTON PLANTATION  
 LOT 404  
 WAVERLY WAY  
 NORTH CAROLINA  
 HARNETT COUNTY ANDERSON CREEK TOWNSHIP

DRAWN BY <b>KDF</b>	DATE <b>6/21/24</b>
CHECKED BY <b>MPG</b>	SCALE <b>1" = 60'</b>