

LEFT ELEVATION
SCALE: 1/4" = 1'-0"



REAR ELEVATION
SCALE: 1/4" = 1'-0"



RIGHT ELEVATION
SCALE: 1/4" = 1'-0"



FRONT ELEVATION
SCALE: 1/4" = 1'-0"



PRELIM
FINAL
04-13-2021
REVISION

MONTREAL
CRAWLSPACE



advancedhouseplans
www.advancedhouseplans.com | 844.875.9838

ADVANCED HOUSE PLANS IS A PROFESSIONAL RESIDENTIAL DESIGN FIRM LOCATED IN OHIO. WE BECAUSE SITE CONDITIONS VARY, AND CANNOT GUARANTEE THAT THESE PLANS SHOULD NOT BE UNDERTAKEN WITHOUT THE CONSULTATION OF A PROFESSIONAL ENGINEER OR ARCHITECT. ALL DIMENSIONS, MATERIALS, FINISHES, AND CODES ARE SUBJECT TO CHANGE WITHOUT NOTICE. THE PURCHASER OF THESE PLANS IS RESPONSIBLE FOR OBTAINING ALL NECESSARY PERMITS AND REGULATIONS PRIOR TO CONSTRUCTION. THAT MAY OCCUR DURING OR AFTER THE BUILDING PROCESS.

© 2021
29935

SHEET
2
OF
1

The purchaser of these plans is given the limited license to reproduce these plans for construction purposes only and further distribution is illegal. Do not scale prints - see dimensions.

OPENING ID	TYPE	PRODUCT CODE	SIZE	COUNT
1	WINDOW	30X48 CASEMENT 1	2'-6" x 4'-0"	1
2	WINDOW	36X72 CASEMENT 1	3'-0" x 6'-0"	4
3	WINDOW	24X42 CASEMENT 1	2'-0" x 3'-6"	1
4	WINDOW	42X72 CASEMENT 1	3'-6" x 6'-0"	1
5	WINDOW	24X36 CASEMENT 1	2'-0" x 3'-0"	1
A	SLIDING DOOR	12X80 SLIDING GLASS 2	6'-0" x 6'-8"	1
B	DOOR	32X80 COLONIAL E 1	2'-8" x 6'-8"	1
C	DOOR	36X80 GLASS 1	3'-0" x 6'-8"	1
D	GARAGE	216X36 STABLE	18'-0" x 8'-0"	1
E	DOOR	28X80 COLONIAL E 1	2'-4" x 6'-8"	1
F	DOOR	36X80 COLONIAL E 2	3'-0" x 6'-8"	1
G	DOOR	24X80 COLONIAL E 1	2'-0" x 6'-8"	1
H	DOOR	30X80 COLONIAL E 1	2'-6" x 6'-8"	1

- GENERAL NOTES:**
1. ALL MAIN LEVEL WALLS ARE 9'-1 1/8" HIGH UNLESS NOTED OTHERWISE
 2. ALL ANGLED WALLS ARE @ 45 DEG. UNLESS NOTED OTHERWISE
 3. ALL EXTERIOR WALLS ARE 4" (3 1/2" STUD/2" SHEATHING)
 4. ALL INTERIOR WALLS ARE 3 1/2" UNLESS NOTED OTHERWISE
 5. MECH. LOCATION DETERMINED PER CONTRACTOR

ELECTRICAL	QTY	SYMBOL
CEILING CLASSIC	1	[Symbol]
can light 6 inch ceiling classic	1	[Symbol]
EXTERIOR CAN LIGHT	1	[Symbol]
exterior light 03	4	[Symbol]
GARBAGE DISPOSAL	1	[Symbol]
Garage Door outlet	1	[Symbol]
LIGHT	4	[Symbol]
PLUMBER SWITCH	1	[Symbol]
Smoke Detector	2	[Symbol]
table tv outlet	3	[Symbol]
Fan	1	[Symbol]
light	2	[Symbol]
outlet	29	[Symbol]
outlet 220v	1	[Symbol]
outlet gfi	14	[Symbol]
outlet gfi weatherproof	1	[Symbol]
outlet up	3	[Symbol]
switch	8	[Symbol]
switch 3 way	11	[Symbol]
switch 4 way	3	[Symbol]
wall mounted 03 3 lights	1	[Symbol]

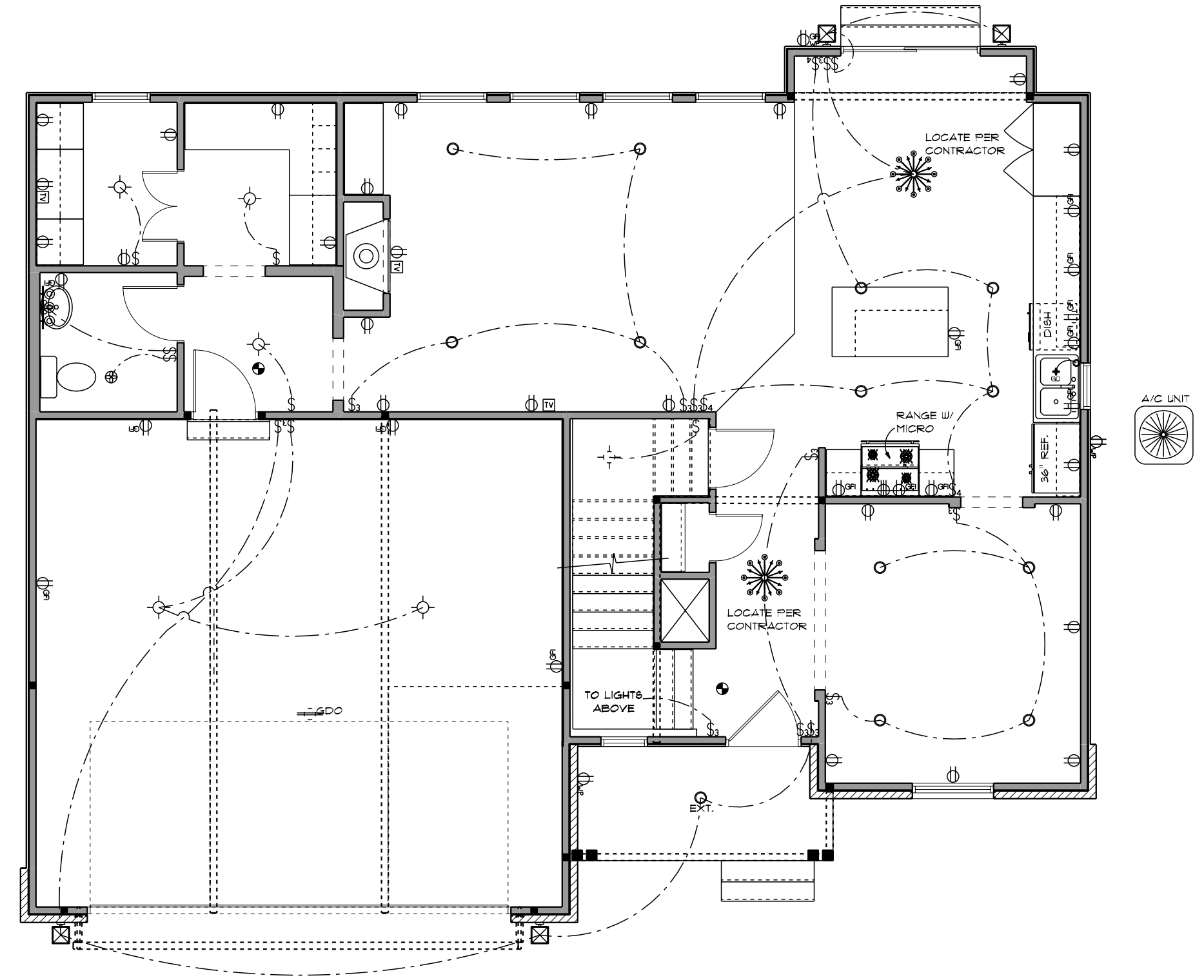

MAIN LEVEL ELECTRICAL PLAN
SCALE: 3/8" = 1'-0"

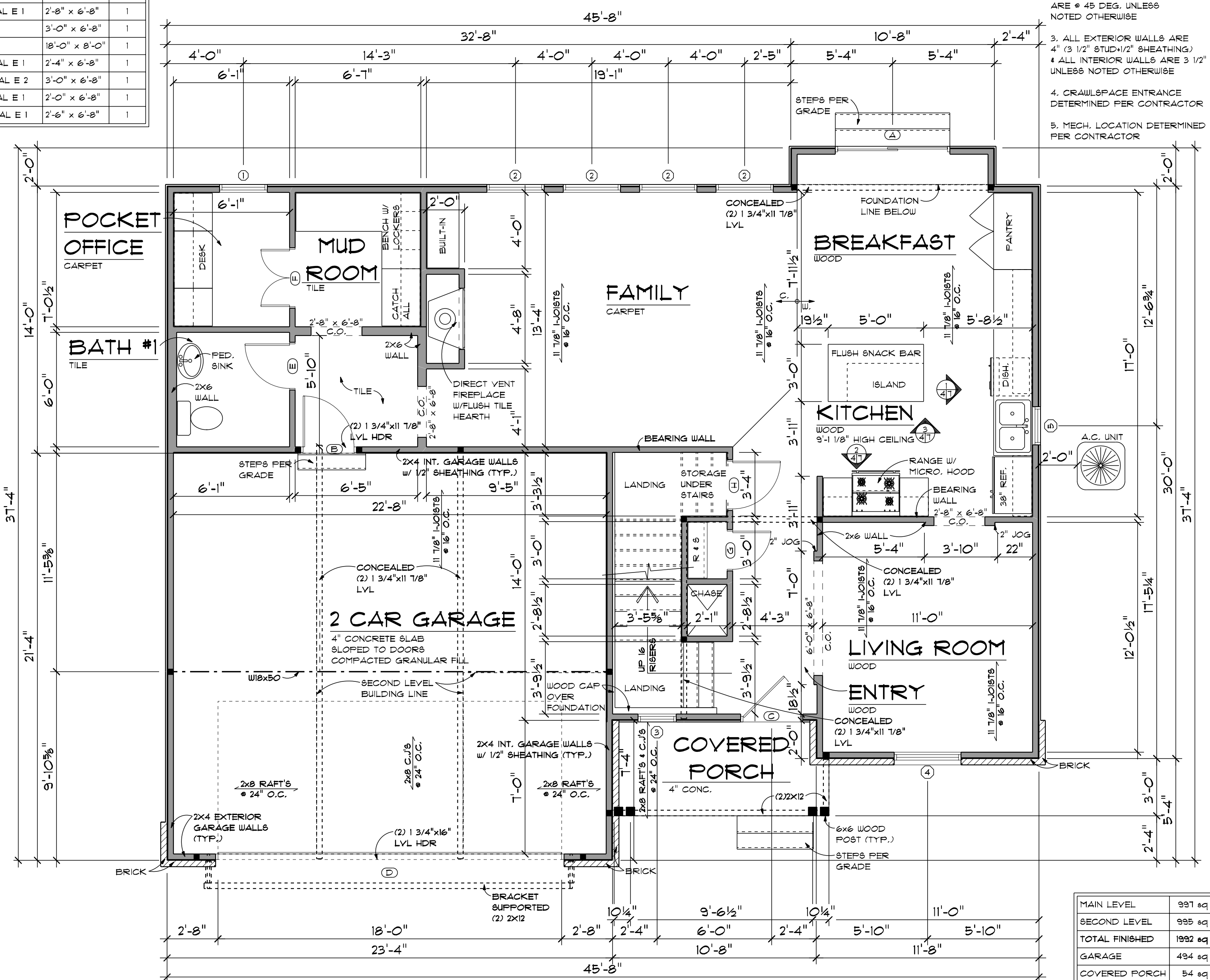

MAIN LEVEL FLOOR PLAN
SCALE: 1/4" = 1'-0"

MAIN LEVEL	997 sq ft.
SECOND LEVEL	988 sq ft.
TOTAL FINISHED	1985 sq ft.
GARAGE	494 sq ft.
COVERED PORCH	54 sq ft.

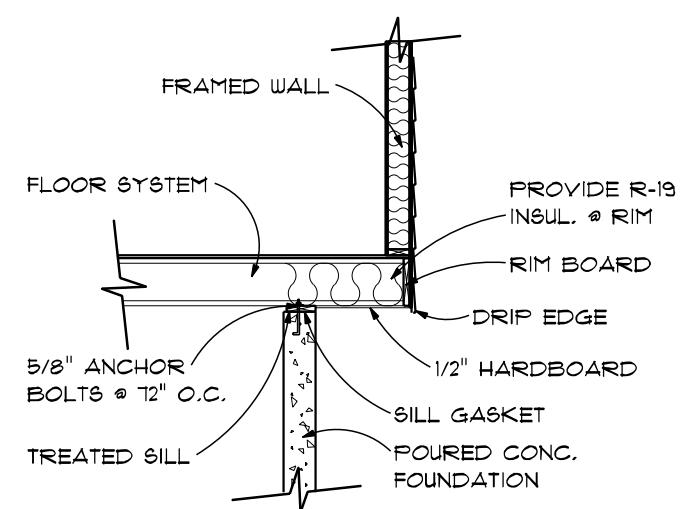

TYP. CANTILEVER
SCALE: 1/4" = 1'-0"

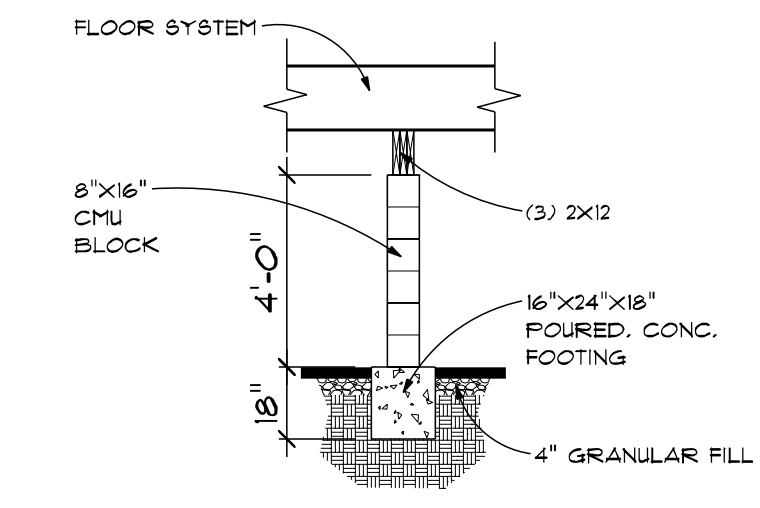

CRAWLSPACE CMU PIER DETAIL
SCALE: 1/4" = 1'-0"

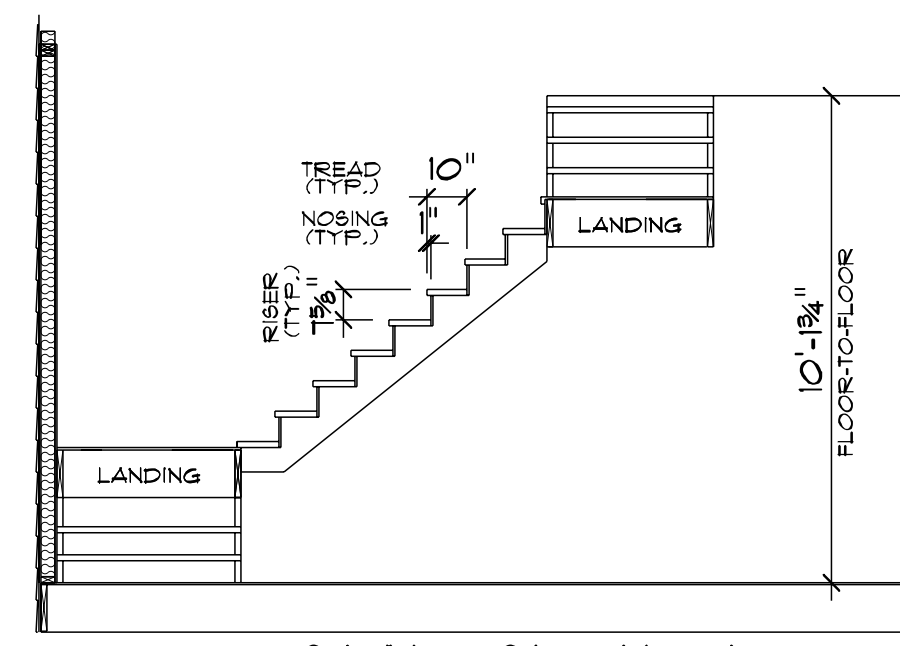

STAIR SECTION
SCALE: 1/4" = 1'-0"

- NOTES:
1. PROVIDE HANDRAIL PER CODE.
 2. MAINTAIN 6'-8" MIN. HEADROOM PER CODE.
 3. VERIFY FINISH FLOOR MATERIALS W/ CONTRACTOR & ADJUST AS NECESSARY.
 4. VERIFY FLOOR-TO-FLOOR & RISER DIMENSIONS W/ AS-BUILT CONDITIONS PRIOR TO STAIR CONSTRUCTION.

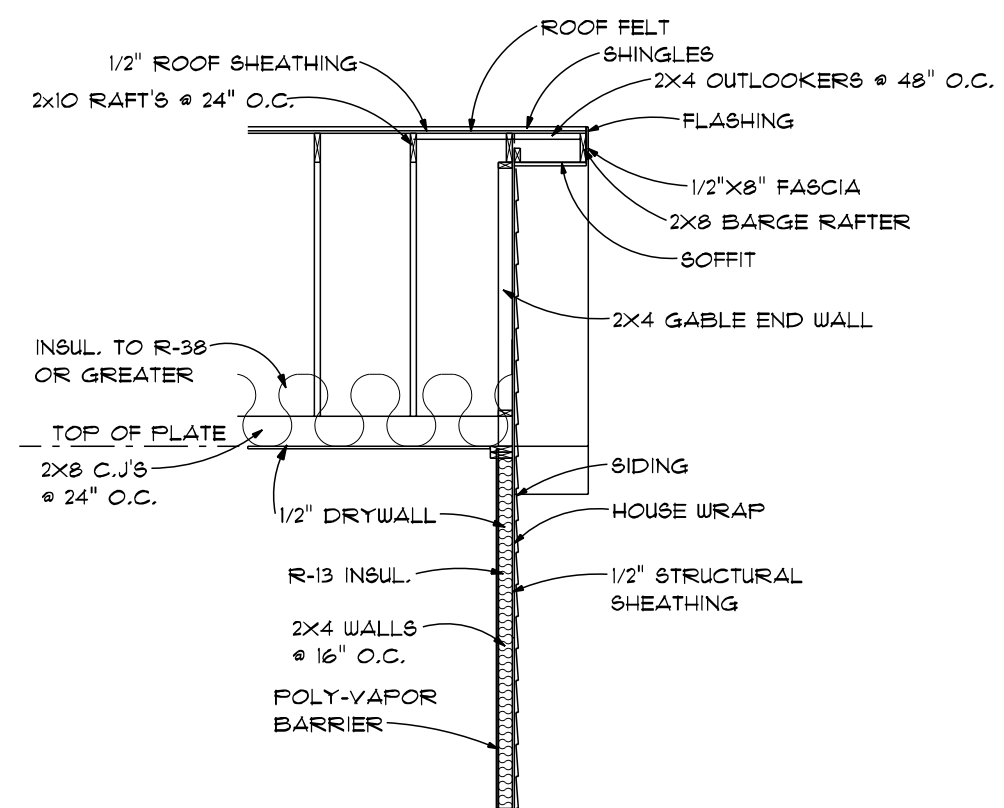

TYP. GABLE END SECTION
SCALE: 1/4" = 1'-0"

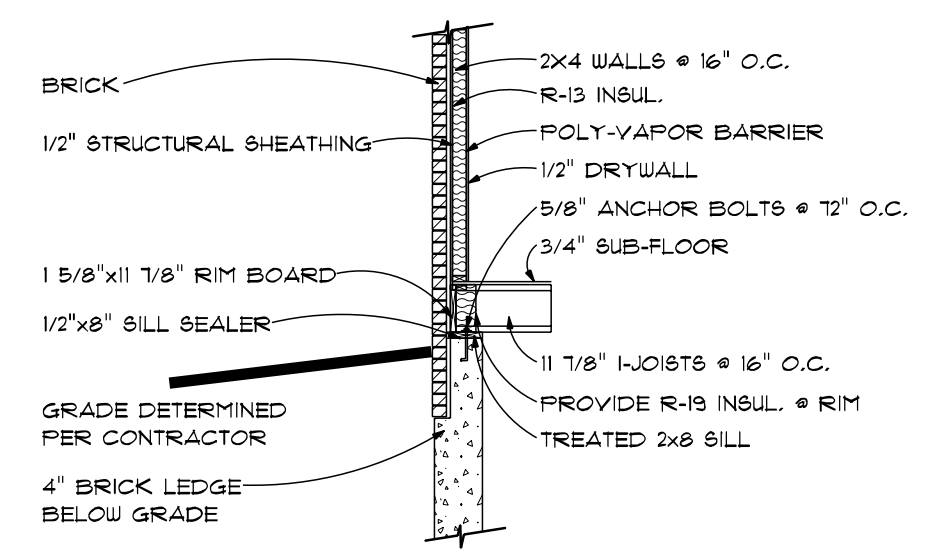

BRICK LEDGE DETAIL
SCALE: 1/4" = 1'-0"

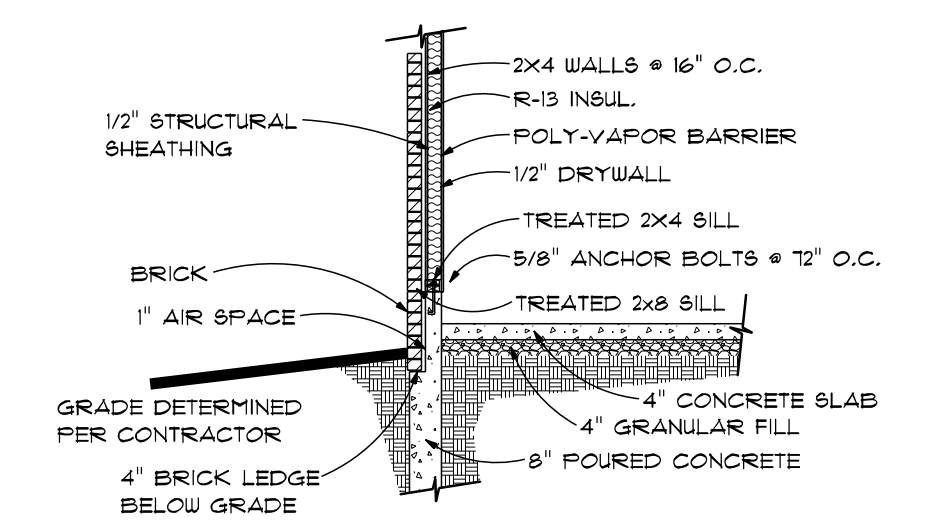

GARAGE BRICK LEDGE DETAIL
SCALE: 1/4" = 1'-0"

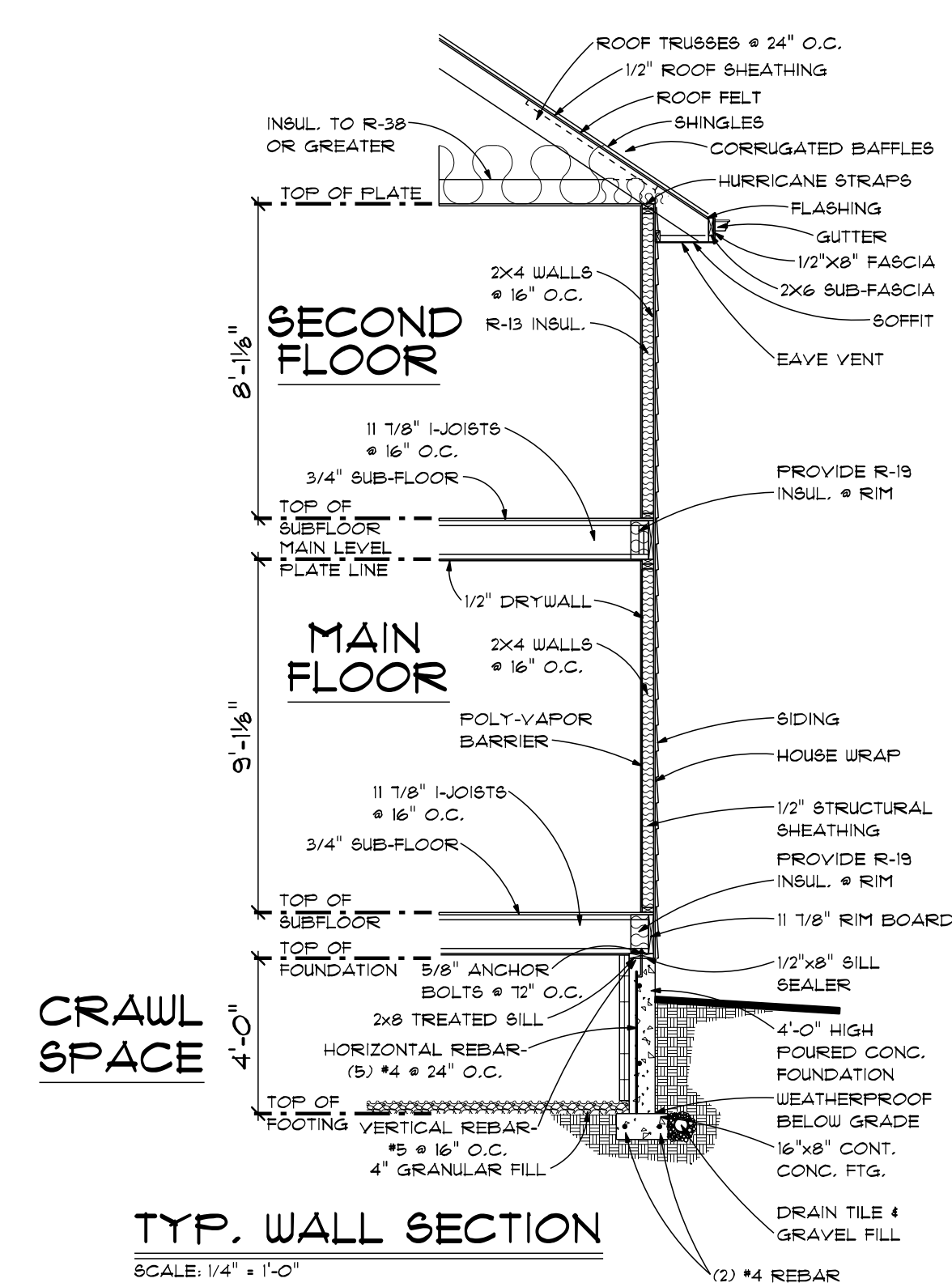

TYP. WALL SECTION
SCALE: 1/4" = 1'-0"

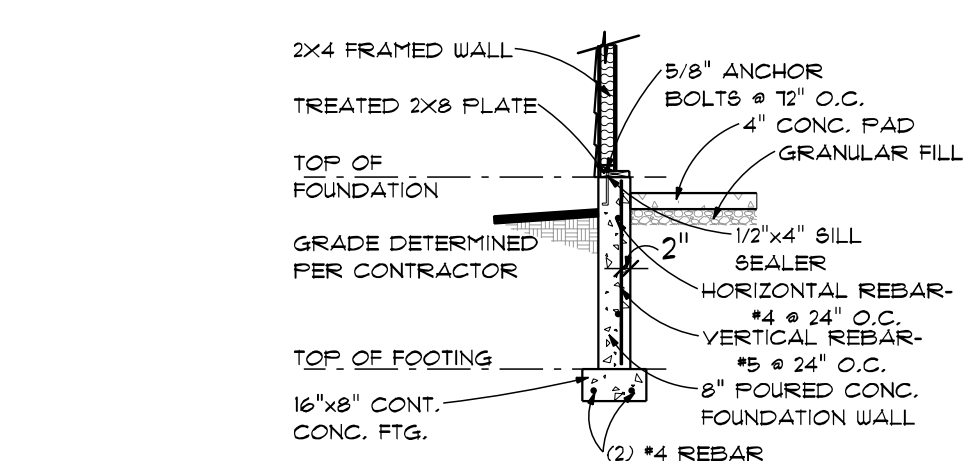

TYP. GARAGE WALL
SCALE: 1/4" = 1'-0"

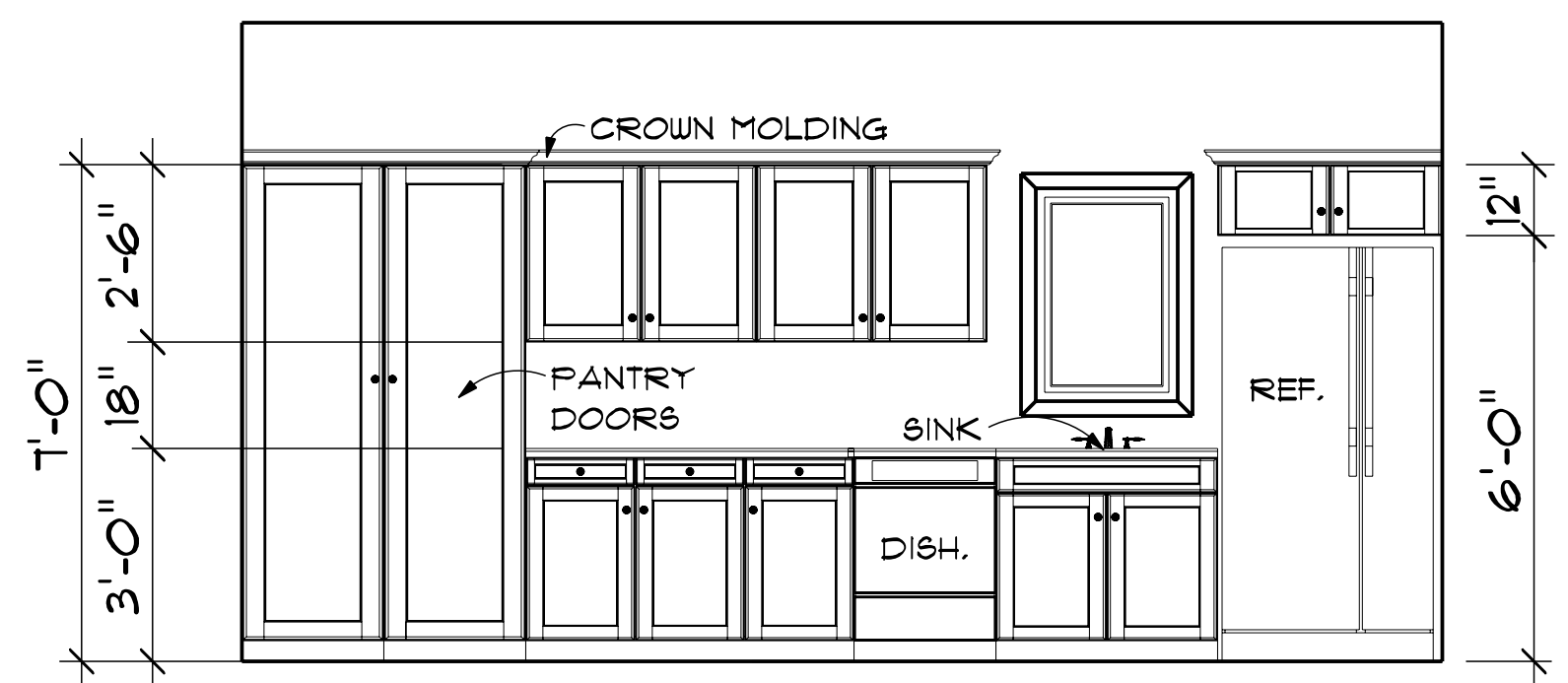

DETAIL 1

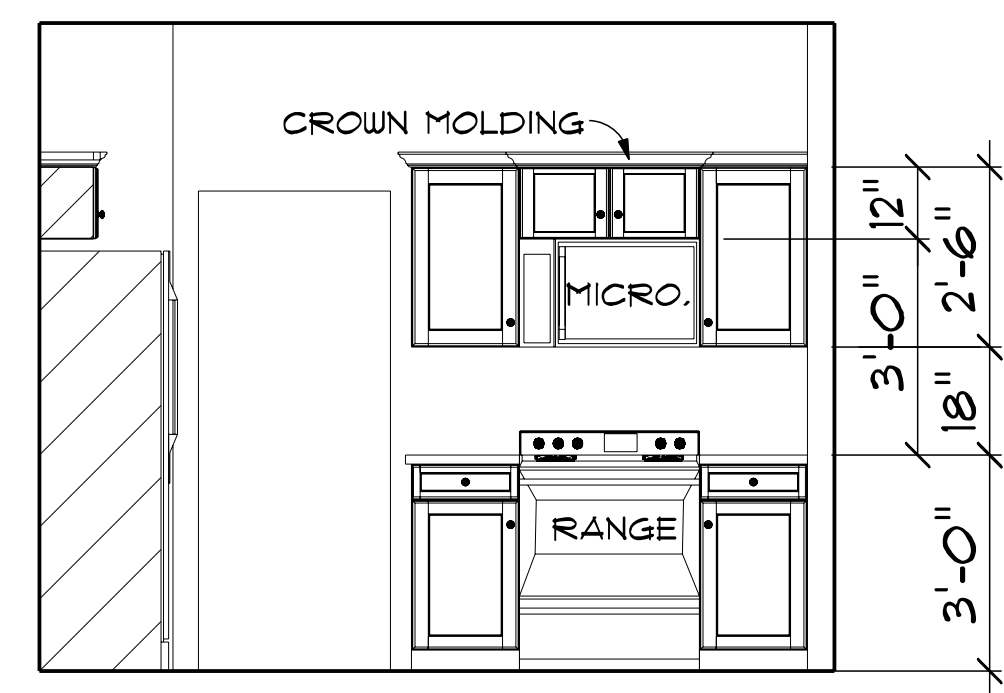

DETAIL 2

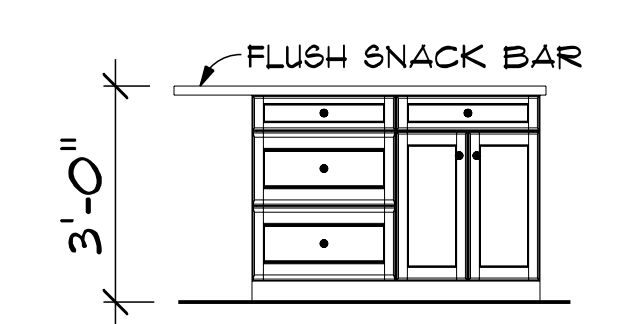

DETAIL 3

CABINET DETAILS

SCALE: 3/8" = 1'-0"



PRELIM
FINAL
04-13-2021
REVISION

MONTREAL
CRAWLSPACE



advancedhouseplans
www.advancedhouseplans.com | 844.675.9838

ADVANCED HOUSE PLANS IS A PROFESSIONAL RESIDENTIAL DESIGN FIRM LOCATION: CHAMPAINE, IL BECAUSE SITE CONDITIONS VARY, ANY CANNOT BE GUARANTEED. THESE PLANS SHOULD NOT BE UNDERTAKEN WITHOUT THE CONSULTATION OF A PROFESSIONAL ENGINEER. ALL DIMENSIONS, MATERIALS, FINISHES, CODE & SITE REQUIREMENTS PRIOR TO CONSTRUCTION. THAT MAY OCCUR DURING OR AFTER THE BUILDING PROCESS.

© 2021
29935

SHEET
1
1-0

The purchaser of these plans is given the limited license to reproduce these plans for construction purposes only and further distribution is illegal. Do not scale prints - see dimensions.