

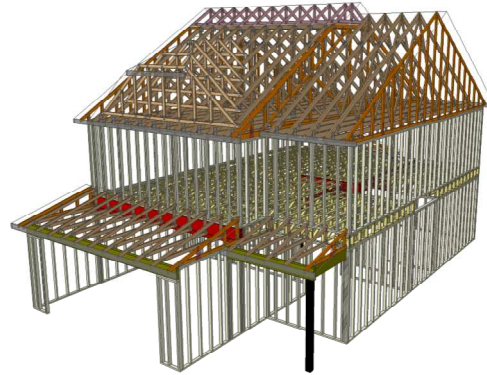

Carter Sanford Component Plant
298 Harvey Faulk Rd
Sanford, NC 27332

Phone #:919-775-1450

Builder: DRB HOMES
Model: 71 FaNC
MALBEC 4.1



THE PLACEMENT PLAN NOTES:

1. The Placement Plan is a diagram for truss installation. It is not an engineered drawing and has not been reviewed by an engineer. The Owner/Building Designer is responsible for obtaining an engineer's review if one is required by the local jurisdiction.
2. The responsibilities of the Owner, Contractor, Building Designer, Component Designer and Component Manufacturer shall be as set forth in ANSI/TPI 1. Capitalized terms shall be as defined in ANSI/TP 1 unless otherwise indicated.
3. Each Component is designed as an individual component utilizing information provided by others. The Owner/Building Designer is responsible for reviewing all Component Submittal Packages and individual Component Design Drawings for compliance with the Construction Documents and compatibility with the overall Building design.
4. Contractor will not proceed with component installation until the Owner/Building Designer has reviewed the Component Submittal Package. Questions on the suitability of any Component will be resolved by the Building Designer.
5. The Building Designer and Contractor are responsible for all temporary and permanent bracing.
6. The Placement Plan assumes the building is dimensionally correct, structurally sound, and in a suitable condition to support each Component during installation and thereafter, including but not limited to installation of all bearing points. Proper design and construction of all structural components, including foundations, headers, beams, walls and columns are the responsibility of the Owner, Building Designer and Contractor.
7. Do not cut, drill, or modify any Component without first consulting the Component Manufacturer or Building Designer. Damaged Components shall not be installed unless directed by the Building Designer or approved by the Component Manufacturer.
8. Components must be handled and installed following all applicable safety standards and best practices, including but not limited to BCSI, OSHA, TPI and local codes. Failure to properly handle, brace or otherwise install Component can result in serious injury or death.

Approved by: _____

Date: _____

Fab Type	Net Qty	Pieces	Product	Length	PlotID
FF	2	2	2.0 Rigidlam DF LVL 1-3/4 x 14	10' 0"	FB2-2
FF	3	3	2.0 Rigidlam DF LVL 1-3/4 x 18	22' 0"	FB1-3

Qty	Product	Manuf	Truss Connector Total List
23	THA422	Simpson	
10	THAC422	Simpson	

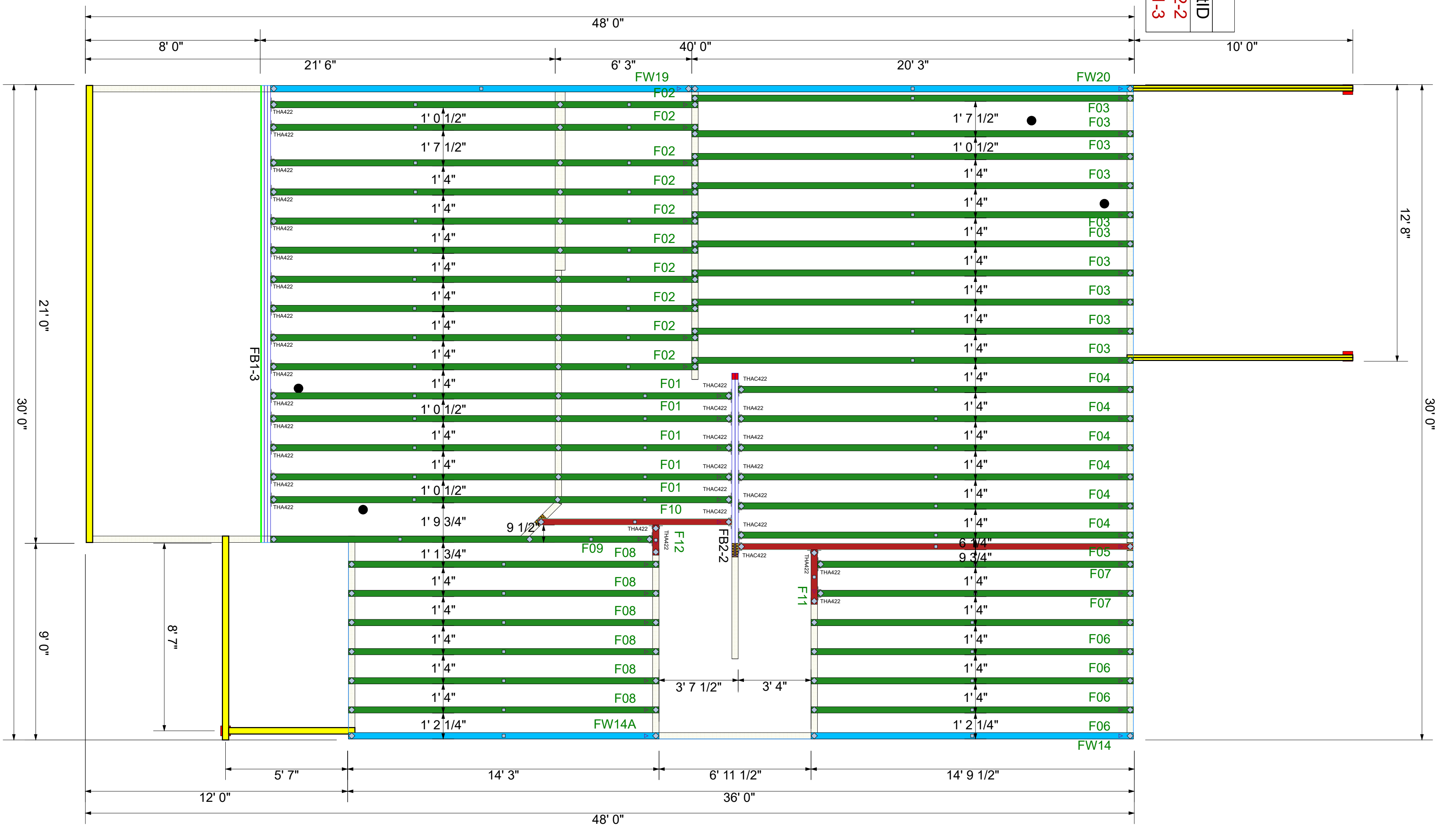

** FRAMER MUST REFER TO PLANS WHILE SETTING COMPONENTS. **

** DAMAGED COMPONENTS SHOULD NOT BE INSTALLED UNLESS TOLD TO BY THE COMPONENT PLANT. **

** TRIANGULAR SYMBOL NEAR END OF TRUSS INDICATES LEFT END OF TRUSS AS SHOWN ON INDIVIDUAL TRUSS DRAWINGS. **

** PLUMBING DROPS NOTED ARE IN THE APPROXIMATE LOCATIONS PER PLAN. BUILDER TO VERIFY LOCATIONS BEFORE SETTING TRUSSES. **

** REFER TO FINAL TRUSS ENGINEERING SHEETS FOR PLY TO PLY CONNECTIONS. **

** GIRDERS MUST BE FULLY CONNECTED TOGETHER PRIOR TO ADDING ANY LOADS. **

** DIMENSIONS ARE READ AS: FOOT-INCH-SIXTEENTH. **

** TRUSS TO TRUSS CONNECTIONS ARE TOE-NAILED, UNLESS NOTED OTHERWISE. **

Scale:	NTS
Date:	2/26/2024
Designer:	ND
Project Number:	24020110
Sheet Number:	1/1

DRB HOMES NC LLC
71 FARM AT NEILLS CREEK
MALBEC 4.1
**COMPONENT
PLACEMENT PLAN**



THIS IS A TRUSS PLACEMENT DIAGRAM ONLY. These trusses are designed as individual components to be incorporated into the building design at the specification of the building designer. See individual design sheets for each truss design identified on the placement drawing. The building designer is responsible for temporary and permanent bracing of the roof and floor systems and for the overall structure. The design of the truss support structure including headers, beams, walls, and columns is the responsibility of the building designer. For general guidance regarding the bracing, consult "Bracing of Wood Truss" available from the Truss Plate Institute, 583 D'Onifrio Drive, Madison, WI 53179

Revisions
00/00/00 Name
00/00/00 Name
00/00/00 Name
00/00/00 Name

Trenco

818 Soundside Rd
Edenton, NC 27932

Re: 24020110
DRB - 71 FaNC

The truss drawing(s) referenced below have been prepared by Truss Engineering Co. under my direct supervision based on the parameters provided by Carter Components (Sanford, NC)).

Pages or sheets covered by this seal: I63855449 thru I63855483

My license renewal date for the state of North Carolina is December 31, 2024.

North Carolina COA: C-0844

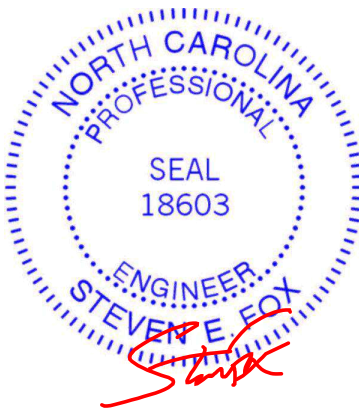

February 27, 2024

Fox, Steve

IMPORTANT NOTE: The seal on these truss component designs is a certification that the engineer named is licensed in the jurisdiction(s) identified and that the designs comply with ANSI/TPI 1. These designs are based upon parameters shown (e.g., loads, supports, dimensions, shapes and design codes), which were given to MiTek or TRENCO. Any project specific information included is for MiTek's or TRENCO's customers file reference purpose only, and was not taken into account in the preparation of these designs. MiTek or TRENCO has not independently verified the applicability of the design parameters or the designs for any particular building. Before use, the building designer should verify applicability of design parameters and properly incorporate these designs into the overall building design per ANSI/TPI 1, Chapter 2.

Job 24020110	Truss A01	Truss Type Piggyback Base	Qty 6	Ply 1	DRB - 71 FaNC Job Reference (optional)	163855449
-----------------	--------------	------------------------------	----------	----------	---	-----------

Carter Components (Sanford, NC), Sanford, NC - 27332,

Run: 8.63 S Nov 1 2023 Print: 8.630 S Nov 1 2023 MiTek Industries, Inc. Mon Feb 26 11:35:07
ID:Gdxs?AHeSaFuA1U3?nxAzyHf-RfC?PsB70Hq3NSgPqnl8w3uITXbGKWrCDoi7J4zJC?f

Page: 1

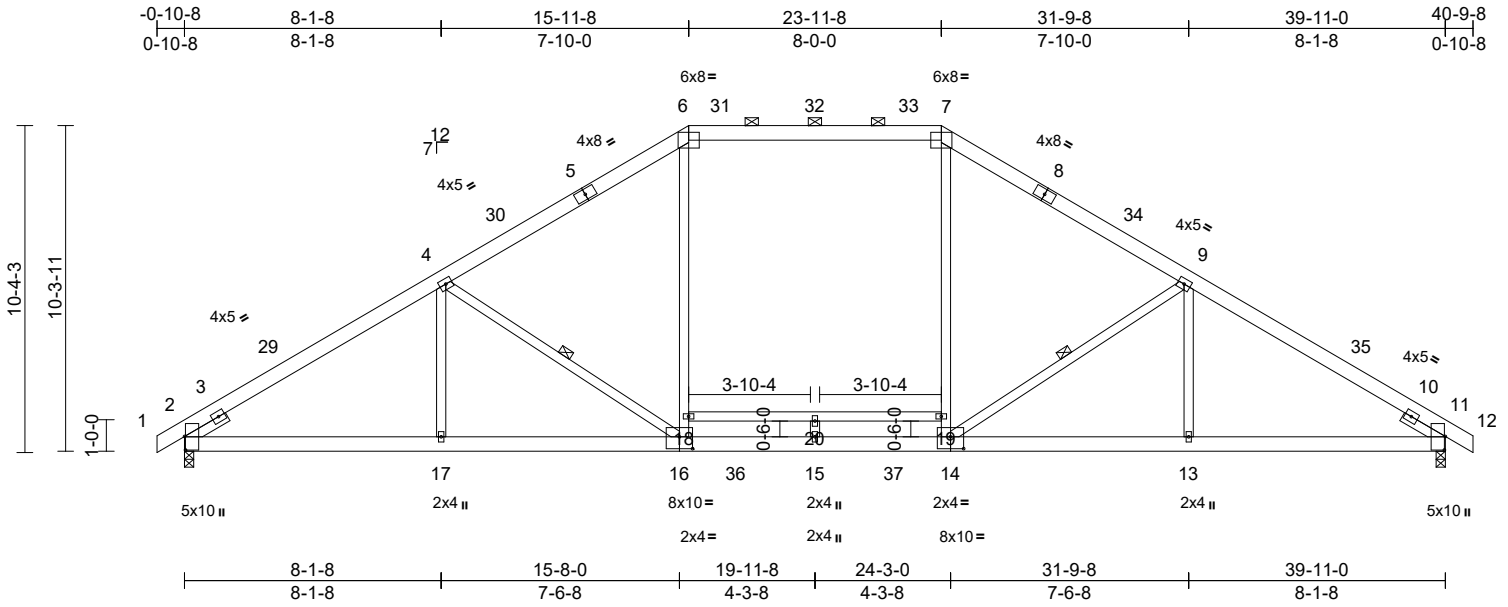

Scale = 1:72.9
Plate Offsets (X, Y): [2:0-5-2,0-0-6], [11:0-5-2,0-0-6], [14:0-5-0,0-4-8], [16:0-5-0,0-4-8]

Loading	(psf)	Spacing	2-0-0	CSI	DEFL	in	(loc)	l/defl	L/d	PLATES	GRIP	
TCLL (roof)	20.0	Plate Grip DOL	1.15	TC	0.77	Vert(LL)	-0.42	16-17	>999	240	MT20	244/190
Snow (Pf)	20.0	Lumber DOL	1.15	BC	0.96	Vert(CT)	-0.51	16-17	>948	180		
TCDL	10.0	Rep Stress Incr	YES	WB	0.34	Horz(CT)	0.08	11	n/a	n/a		
BCLL	0.0*	Code	IRC2018/TPI2014	Matrix-MSH								
BCDL	10.0											
											Weight: 290 lb	FT = 20%

LUMBER
TOP CHORD 2x6 SP No.2
BOT CHORD 2x6 SP 2400F 2.0E *Except* 16-14:2x6 SP No.2
WEBS 2x4 SP No.3
SLIDER Left 2x4 SP No.3 -- 1-6-0, Right 2x4 SP No.3 -- 1-6-0

BRACING
TOP CHORD Structural wood sheathing directly applied or 3-2-10 oc purlins, except 2-0-0 oc purlins (4-1-5 max.): 6-7.
BOT CHORD Rigid ceiling directly applied or 2-2-0 oc bracing.
WEBS 1 Row at midpt 4-16, 9-14

REACTIONS (size) 2=0-3-8, 11=0-3-8
Max Horiz 2=231 (LC 13)
Max Uplift 2=-72 (LC 14), 11=-72 (LC 15)
Max Grav 2=1877 (LC 39), 11=1877 (LC 39)

FORCES (lb) - Maximum Compression/Maximum Tension
TOP CHORD 1-2=0/26, 2-4=-2843/103, 4-6=-2371/57, 6-7=-1872/105, 7-9=-2371/57, 9-11=-2843/103, 11-12=0/26
BOT CHORD 2-17=-190/2361, 15-17=-125/2361, 13-15=0/2361, 11-13=-49/2361
WEBS 4-17=-47/215, 4-16=-740/324, 16-18=0/646, 6-18=0/647, 14-19=0/646, 7-19=0/647, 9-14=-740/324, 9-13=-47/215, 18-20=0/106, 19-20=0/106, 15-20=0/22

NOTES
1) Unbalanced roof live loads have been considered for this design.

- Wind: ASCE 7-16; Vult=130mph (3-second gust) Vasd=103mph; TCDL=6.0psf; BCDL=6.0psf; h=25ft; Cat. II; Exp B; Enclosed; MWFRS (envelope) exterior zone and C-C Exterior(2E) -0-10-8 to 3-1-6, Interior (1) 3-1-6 to 10-3-12, Exterior(2R) 10-3-12 to 29-7-4, Interior (1) 29-7-4 to 36-9-10, Exterior(2E) 36-9-10 to 40-9-8 zone; cantilever left and right exposed; end vertical left and right exposed; C-C for members and forces & MWFRS for reactions shown; Lumber DOL=1.60 plate grip DOL=1.60
- TCLL: ASCE 7-16; Pr=20.0 psf (roof LL: Lum DOL=1.15 Plate DOL=1.15); Pf=20.0 psf (Lum DOL=1.15 Plate DOL=1.15); Is=1.0; Rough Cat B; Fully Exp.; Ce=0.9; Cs=1.00; Ct=1.10
- Unbalanced snow loads have been considered for this design.
- This truss has been designed for greater of min roof live load of 12.0 psf or 1.00 times flat roof load of 20.0 psf on overhangs non-concurrent with other live loads.
- 200.0lb AC unit load placed on the bottom chord, 19-11-8 from left end, supported at two points, 5-0-0 apart.
- Provide adequate drainage to prevent water ponding.
- This truss has been designed for a 10.0 psf bottom chord live load nonconcurrent with any other live loads.
- * This truss has been designed for a roof live load of 20.0psf on the bottom chord in all areas where a rectangle 3-06-00 tall by 2-00-00 wide will fit between the bottom chord and any other members.
- One H2.5A Simpson Strong-Tie connectors recommended to connect truss to bearing walls due to UPLIFT at jt(s) 2 and 11. This connection is for uplift only and does not consider lateral forces.
- This truss is designed in accordance with the 2018 International Residential Code sections R502.11.1 and R802.10.2 and referenced standard ANSI/TPI 1.

12) Graphical purlin representation does not depict the size or the orientation of the purlin along the top and/or bottom chord.
LOAD CASE(S) Standard

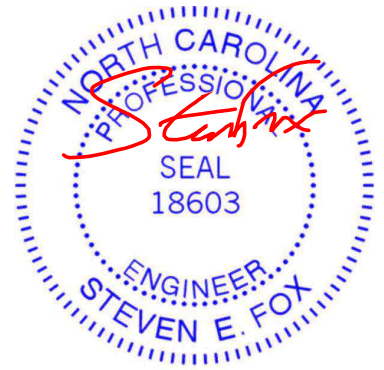

February 27, 2024

WARNING - Verify design parameters and READ NOTES ON THIS AND INCLUDED MITEK REFERENCE PAGE MII-7473 rev. 1/2/2023 BEFORE USE.

Design valid for use only with MiTek® connectors. This design is based only upon parameters shown, and is for an individual building component, not a truss system. Before use, the building designer must verify the applicability of design parameters and properly incorporate this design into the overall building design. Bracing indicated is to prevent buckling of individual truss web and/or chord members only. Additional temporary and permanent bracing is always required for stability and to prevent collapse with possible personal injury and property damage. For general guidance regarding the fabrication, storage, delivery, erection and bracing of trusses and truss systems, see **ANSI/TPI1 Quality Criteria and DSB-22** available from Truss Plate Institute (www.tpinst.org) and **BCSI Building Component Safety Information** available from the Structural Building Component Association (www.sbcacomponents.com)



818 Soundside Road
Edenton, NC 27932

Job 24020110	Truss A02	Truss Type Piggyback Base	Qty 4	Ply 1	DRB - 71 FaNC Job Reference (optional)	163855450
-----------------	--------------	------------------------------	----------	----------	---	-----------

Carter Components (Sanford, NC), Sanford, NC - 27332,

Run: 8.63 E May 25 2023 Print: 8.630 E May 25 2023 MiTek Industries, Inc. Tue Feb 27 11:38:11
ID:RYhNtKCAhGhQyV756JSEzypGh-p8kshdKKFY5hygXIAYNVNB02im0cNzFDaEQVbzyg7x

Page: 1

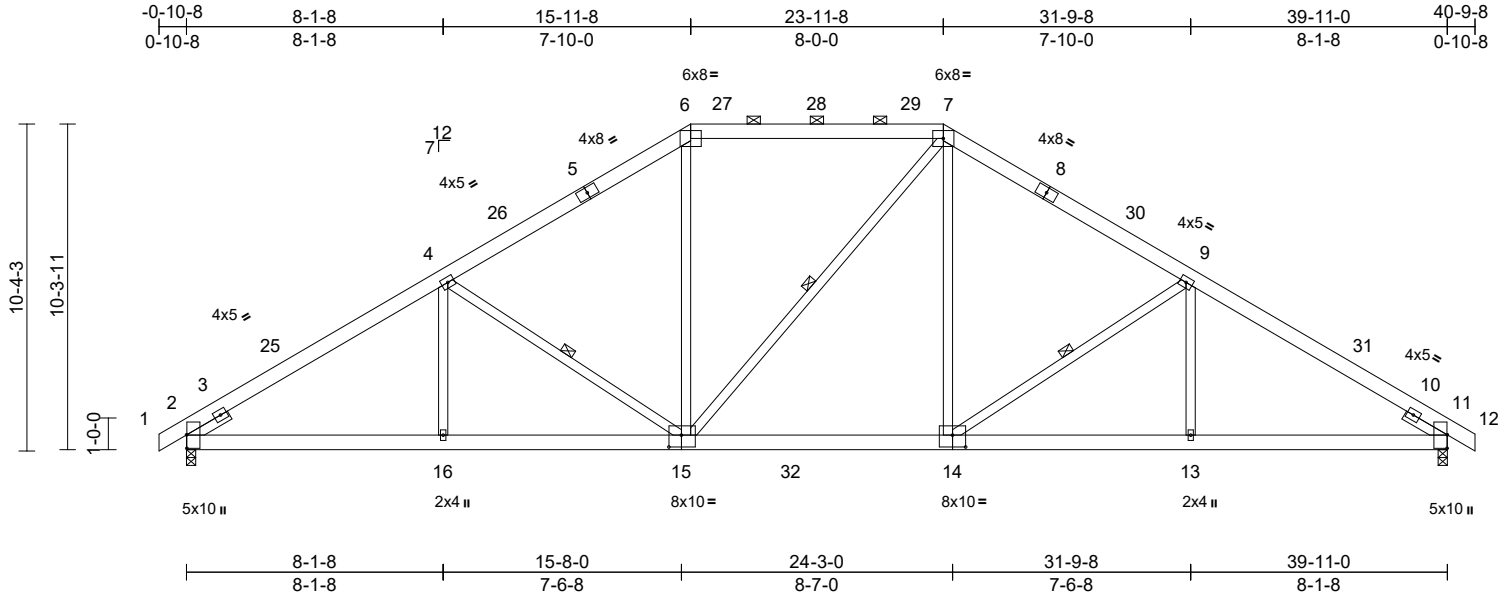

Scale = 1:72.9

Plate Offsets (X, Y): [2:0-5-2,0-0-2], [11:0-5-2,0-0-2], [14:0-5-0,0-4-8], [15:0-4-12,0-4-8]

Loading	(psf)	Spacing	2-0-0	CSI	DEFL	in	(loc)	l/defl	L/d	PLATES	GRIP	
TCLL (roof)	20.0	Plate Grip DOL	1.15	TC	0.68	Vert(LL)	-0.15	14-15	>999	240	MT20	244/190
Snow (Pf)	20.0	Lumber DOL	1.15	BC	0.84	Vert(CT)	-0.26	14-15	>999	180		
TCDL	10.0	Rep Stress Incr	YES	WB	0.32	Horz(CT)	0.10	11	n/a	n/a		
BCLL	0.0*	Code	IRC2018/TPI2014	Matrix-MSH								
BCDL	10.0											
											Weight: 295 lb	FT = 20%

LUMBER
TOP CHORD 2x6 SP No.2
BOT CHORD 2x6 SP No.2
WEBS 2x4 SP No.3
SLIDER Left 2x4 SP No.3 -- 1-6-0, Right 2x4 SP No.3 -- 1-6-0

BRACING
TOP CHORD Structural wood sheathing directly applied or 3-7-13 oc purlins, except 2-0-0 oc purlins (4-4-9 max.): 6-7.
BOT CHORD Rigid ceiling directly applied or 10-0-0 oc bracing.
WEBS 1 Row at midpt 4-15, 9-14, 7-15

REACTIONS
(lb/size) 2=1649/0-3-8, 11=1649/0-3-8
Max Horiz 2=-231 (LC 12)
Max Uplift 2=-172 (LC 14), 11=-172 (LC 15)
Max Grav 2=1879 (LC 47), 11=1885 (LC 49)

FORCES
(lb) - Maximum Compression/Maximum Tension
TOP CHORD 1-2=0/26, 2-3=-1638/0, 3-25=-2807/226, 4-25=-2646/257, 4-26=-2292/221, 5-26=-2139/234, 5-6=-2124/255, 6-27=-1828/276, 27-28=-1828/276, 28-29=-1828/276, 7-29=-1828/276, 7-8=-2136/255, 8-30=-2151/234, 9-30=-2304/221, 9-31=-2658/257, 10-31=-2819/227, 10-11=-1374/0, 11-12=0/26
BOT CHORD 2-16=-255/2451, 15-16=-255/2451, 15-32=0/1837, 14-32=0/1837, 13-14=-100/2348, 11-13=-100/2348
WEBS 4-16=0/249, 4-15=-732/228, 6-15=-12/732, 7-14=-30/786, 9-14=-733/229, 9-13=0/251, 7-15=-230/233

NOTES
1) Unbalanced roof live loads have been considered for this design.

- Wind: ASCE 7-16; Vult=130mph (3-second gust) Vasd=103mph; TCDL=6.0psf; BCDL=6.0psf; h=25ft; Cat. II; Exp B; Enclosed; MWFRS (envelope) exterior zone and C-C Exterior(2E)-0-10-8 to 3-1-6, Interior (1) 3-1-6 to 10-3-12, Exterior(2R) 10-3-12 to 29-7-4, Interior (1) 29-7-4 to 36-9-10, Exterior(2E) 36-9-10 to 40-9-8 zone; cantilever left and right exposed; end vertical left and right exposed; C-C for members and forces & MWFRS for reactions shown; Lumber DOL=1.60 plate grip DOL=1.60
- TCLL: ASCE 7-16; Pr=20.0 psf (roof LL: Lum DOL=1.15 Plate DOL=1.15); Pf=20.0 psf (Lum DOL=1.15 Plate DOL=1.15); Is=1.0; Rough Cat B; Fully Exp.; Ce=0.9; Cs=1.00; Ct=1.10
- Unbalanced snow loads have been considered for this design.
- This truss has been designed for greater of min roof live load of 12.0 psf or 1.00 times flat roof load of 20.0 psf on overhangs non-concurrent with other live loads.
- Provide adequate drainage to prevent water ponding.
- This truss has been designed for a 10.0 psf bottom chord live load nonconcurrent with any other live loads.
- * This truss has been designed for a live load of 20.0psf on the bottom chord in all areas where a rectangle 3-06-00 tall by 2-00-00 wide will fit between the bottom chord and any other members, with BCDL = 10.0psf.
- One RT4 MiTek connectors recommended to connect truss to bearing walls due to UPLIFT at it(s) 2 and 11. This connection is for uplift only and does not consider lateral forces.
- This truss is designed in accordance with the 2018 International Residential Code sections R502.11.1 and R802.10.2 and referenced standard ANSI/TPI 1.
- Graphical purlin representation does not depict the size or the orientation of the purlin along the top and/or bottom chord.

LOAD CASE(S) Standard

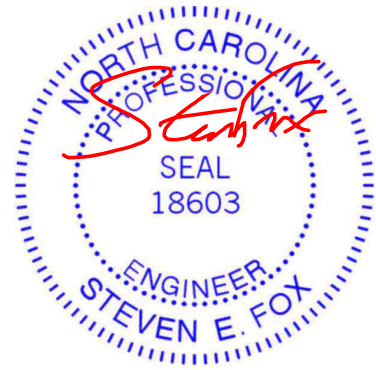

February 27, 2024

WARNING - Verify design parameters and READ NOTES ON THIS AND INCLUDED MITEK REFERENCE PAGE MII-7473 rev. 1/2/2023 BEFORE USE.
Design valid for use only with MiTek® connectors. This design is based only upon parameters shown, and is for an individual building component, not a truss system. Before use, the building designer must verify the applicability of design parameters and properly incorporate this design into the overall building design. Bracing indicated is to prevent buckling of individual truss web and/or chord members only. Additional temporary and permanent bracing is always required for stability and to prevent collapse with possible personal injury and property damage. For general guidance regarding the fabrication, storage, delivery, erection and bracing of trusses and truss systems, see **ANSI/TPI1 Quality Criteria and DSB-22** available from Truss Plate Institute (www.tpinst.org) and **BCSI Building Component Safety Information** available from the Structural Building Component Association (www.sbcacomponents.com)

ENGINEERING BY
TRENCO
A MiTek Affiliate
818 Soundside Road
Edenton, NC 27932

Job 24020110	Truss A03	Truss Type Piggyback Base Supported Gable	Qty 1	Ply 1	DRB - 71 FaNC Job Reference (optional)	163855451
-----------------	--------------	--	----------	----------	---	-----------

Carter Components (Sanford, NC), Sanford, NC - 27332,

Run: 8.63 S Nov 1 2023 Print: 8.630 S Nov 1 2023 MiTek Industries, Inc. Mon Feb 26 11:35:10
ID:hZGCK5eUZHy5oQuxeYaQVjzypGH-RfC?PsB70Hq3NSgPqL8w3uITXbGKwCdoi7J4zJC?f

Page: 1

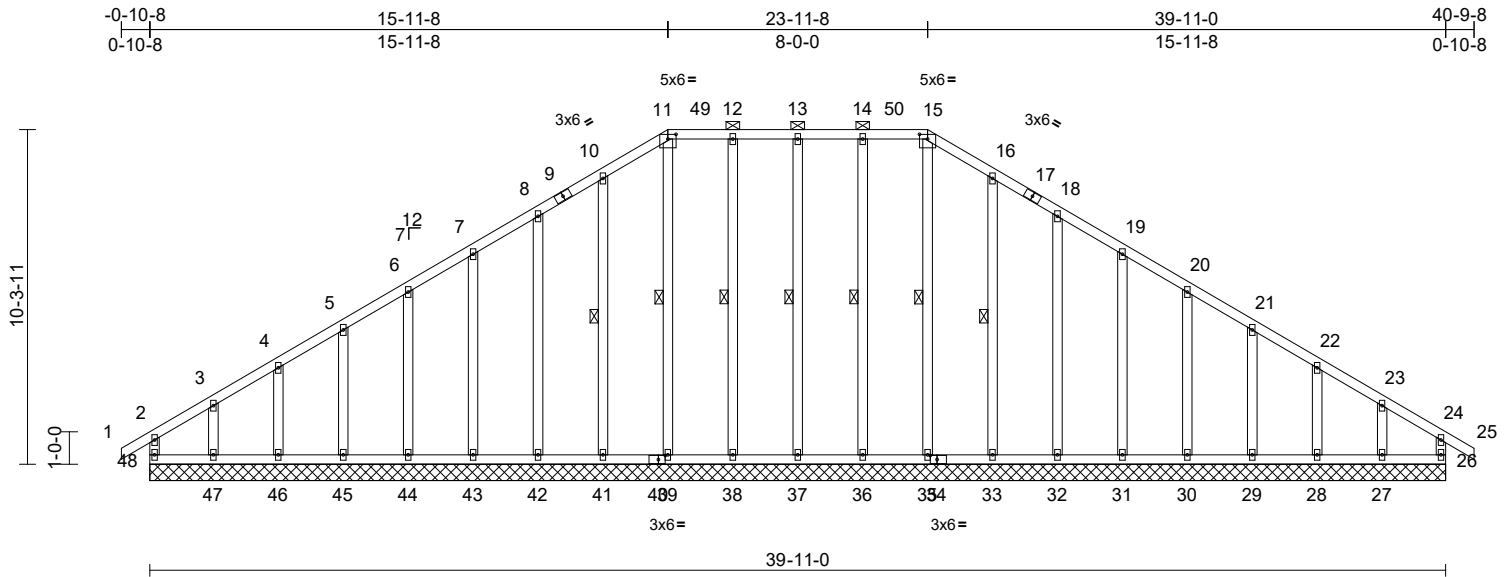

Scale = 1:71

Plate Offsets (X, Y): [11:0-3-0,0-1-12], [15:0-3-0,0-1-12], [34:0-2-8,0-1-8], [40:0-2-8,0-1-8]

Loading	(psf)	Spacing	1-11-4	CSI	DEFL	in	(loc)	l/defl	L/d	PLATES	GRIP	
TCLL (roof)	20.0	Plate Grip DOL	1.15	TC	0.18	Vert(LL)	n/a	-	n/a	999	MT20	244/190
Snow (Pf)	20.0	Lumber DOL	1.15	BC	0.09	Vert(CT)	n/a	-	n/a	999		
TCDL	10.0	Rep Stress Incr	YES	WB	0.20	Horz(CT)	0.01	26	n/a	n/a		
BCLL	0.0*	Code	IRC2018/TPI2014	Matrix-MR								
BCDL	10.0											
											Weight: 310 lb	FT = 20%

LUMBER		Max Grav	WEBS
TOP CHORD	2x4 SP No.2	26=163 (LC 47), 27=193 (LC 25), 28=159 (LC 39), 29=163 (LC 25), 30=186 (LC 43), 31=219 (LC 43), 32=214 (LC 43), 33=227 (LC 43), 35=162 (LC 51), 36=225 (LC 38), 37=212 (LC 38), 38=225 (LC 38), 39=172 (LC 53), 41=227 (LC 41), 42=214 (LC 41), 43=219 (LC 41), 44=186 (LC 41), 45=165 (LC 28), 46=159 (LC 39), 47=217 (LC 24), 48=204 (LC 49)	13-37=-173/50, 12-38=-187/49, 11-39=-133/20, 10-41=-188/72, 8-42=-175/74, 7-43=-180/72, 6-44=-147/72, 5-45=-124/74, 4-46=-120/66, 3-47=-148/114, 14-36=-187/50, 15-35=-123/9, 16-33=-188/71, 18-32=-175/74, 19-31=-180/72, 20-30=-147/72, 21-29=-123/74, 22-28=-121/65, 23-27=-134/105
BOT CHORD	2x4 SP No.2		
WEBS	2x4 SP No.3		
OTHERS	2x4 SP No.3		

BRACING		FORCES
TOP CHORD	Structural wood sheathing directly applied or 6-0-0 oc purlins, except end verticals, and 2-0-0 oc purlins (6-0-0 max.): 11-15.	(lb) - Maximum Compression/Maximum Tension
BOT CHORD	Rigid ceiling directly applied or 6-0-0 oc bracing.	TOP CHORD 2-48=-164/90, 1-2=0/30, 2-3=-177/172, 3-4=-137/134, 4-5=-128/135, 5-6=-114/148, 6-7=-103/176, 7-8=-110/207, 8-10=-136/254, 10-11=-163/298, 11-12=-143/273, 12-13=-143/273, 13-14=-143/273, 14-15=-143/273, 15-16=-163/298, 16-18=-136/254, 18-19=-110/207, 19-20=-84/162, 20-21=-60/119, 21-22=-71/92, 22-23=-80/80, 23-24=-115/107, 24-25=0/30, 24-26=-131/49
WEBS	1 Row at midpt 13-37, 12-38, 11-39, 10-41, 14-36, 15-35, 16-33	BOT CHORD 47-48=-104/115, 46-47=-104/115, 45-46=-104/115, 44-45=-104/115, 43-44=-104/115, 42-43=-104/115, 41-42=-104/115, 39-41=-104/115, 38-39=-104/115, 37-38=-104/115, 36-37=-104/115, 35-36=-104/115, 33-35=-104/115, 32-33=-104/115, 31-32=-104/115, 30-31=-104/115, 29-30=-104/115, 28-29=-104/115, 27-28=-104/115, 26-27=-104/115

REACTIONS	(size)	NOTES
Max Horiz	48=-249 (LC 12)	1) Unbalanced roof live loads have been considered for this design.
Max Uplift	26=-58 (LC 11), 27=-112 (LC 15), 28=-34 (LC 15), 29=-52 (LC 15), 30=-48 (LC 15), 31=-48 (LC 15), 32=-51 (LC 15), 33=-48 (LC 15), 36=-27 (LC 11), 37=-26 (LC 10), 38=-25 (LC 11), 41=-48 (LC 14), 42=-51 (LC 14), 43=-49 (LC 14), 44=-48 (LC 14), 45=-53 (LC 14), 46=-31 (LC 14), 47=-128 (LC 14), 48=-110 (LC 10)	2) Wind: ASCE 7-16; Vult=130mph (3-second gust) Vasd=103mph; TCCL=6.0psf; BCDL=6.0psf; h=25ft; Cat. II; Exp B; Enclosed; MWFRS (envelope) exterior zone and C-C Corner(3E) -0-10-8 to 3-1-6, Exterior(2N) 3-1-6 to 11-11-8, Corner(3R) 11-11-8 to 27-11-8, Exterior (2N) 27-11-8 to 36-9-10, Corner(3E) 36-9-10 to 40-9-8 zone; cantilever left and right exposed ; end vertical left and right exposed; C-C for members and forces & MWFRS for reactions shown; Lumber DOL=1.60 plate grip DOL=1.60

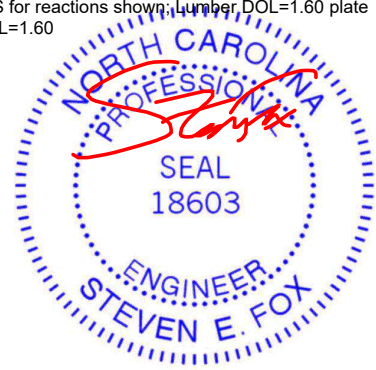

February 27, 2024

Continued on page 2

WARNING - Verify design parameters and READ NOTES ON THIS AND INCLUDED MITEK REFERENCE PAGE MII-7473 rev. 1/2/2023 BEFORE USE.

Design valid for use only with MiTek® connectors. This design is based only upon parameters shown, and is for an individual building component, not a truss system. Before use, the building designer must verify the applicability of design parameters and properly incorporate this design into the overall building design. Bracing indicated is to prevent buckling of individual truss web and/or chord members only. All temporary and permanent bracing is always required for stability and to prevent collapse with possible personal injury and property damage. For general guidance regarding the fabrication, storage, delivery, erection and bracing of trusses and truss systems, see **ANSI/TPI Quality Criteria and DSB-22** available from Truss Plate Institute (www.tpinst.org) and **BCSI Building Component Safety Information** available from the Structural Building Component Association (www.sbcacomponents.com)



818 Soundside Road
Edenton, NC 27932

Job	Truss	Truss Type	Qty	Ply	DRB - 71 FaNC	I63855451
24020110	A03	Piggyback Base Supported Gable	1	1	Job Reference (optional)	

Carter Components (Sanford, NC), Sanford, NC - 27332,

Run: 8.63 S Nov 1 2023 Print: 8.630 S Nov 1 2023 MiTek Industries, Inc. Mon Feb 26 11:35:10
ID:hZGCK5eUZhY5oQuxeYaQVjzypGH-RfC?PsB70Hq3NSgPqnL8w3uITXbGKWrCDoi7J4zJC?f

Page: 2

- 3) Truss designed for wind loads in the plane of the truss only. For studs exposed to wind (normal to the face), see Standard Industry Gable End Details as applicable, or consult qualified building designer as per ANSI/TPI 1.
- 4) TCLK: ASCE 7-16; Pr=20.0 psf (roof LL: Lum DOL=1.15 Plate DOL=1.15); Pf=20.0 psf (Lum DOL=1.15 Plate DOL=1.15); Is=1.0; Rough Cat B; Fully Exp.; Ce=0.9; Cs=1.00; Ct=1.10
- 5) Unbalanced snow loads have been considered for this design.
- 6) This truss has been designed for greater of min roof live load of 12.0 psf or 1.00 times flat roof load of 20.0 psf on overhangs non-concurrent with other live loads.
- 7) Provide adequate drainage to prevent water ponding.
- 8) All plates are 2x4 MT20 unless otherwise indicated.
- 9) Gable requires continuous bottom chord bearing.
- 10) Truss to be fully sheathed from one face or securely braced against lateral movement (i.e. diagonal web).
- 11) Gable studs spaced at 2-0-0 oc.
- 12) This truss has been designed for a 10.0 psf bottom chord live load nonconcurrent with any other live loads.
- 13) * This truss has been designed for a live load of 20.0psf on the bottom chord in all areas where a rectangle 3-06-00 tall by 2-00-00 wide will fit between the bottom chord and any other members.
- 14) Provide mechanical connection (by others) of truss to bearing plate capable of withstanding 110 lb uplift at joint 48, 58 lb uplift at joint 26, 26 lb uplift at joint 37, 25 lb uplift at joint 38, 48 lb uplift at joint 41, 51 lb uplift at joint 42, 49 lb uplift at joint 43, 48 lb uplift at joint 44, 53 lb uplift at joint 45, 31 lb uplift at joint 46, 128 lb uplift at joint 47, 27 lb uplift at joint 36, 48 lb uplift at joint 33, 51 lb uplift at joint 32, 48 lb uplift at joint 31, 48 lb uplift at joint 30, 52 lb uplift at joint 29, 34 lb uplift at joint 28 and 112 lb uplift at joint 27.
- 15) This truss is designed in accordance with the 2018 International Residential Code sections R502.11.1 and R802.10.2 and referenced standard ANSI/TPI 1.
- 16) Graphical purlin representation does not depict the size or the orientation of the purlin along the top and/or bottom chord.

LOAD CASE(S) Standard

WARNING - Verify design parameters and READ NOTES ON THIS AND INCLUDED MITEK REFERENCE PAGE MII-7473 rev. 1/2/2023 BEFORE USE.

Design valid for use only with MiTek® connectors. This design is based only upon parameters shown, and is for an individual building component, not a truss system. Before use, the building designer must verify the applicability of design parameters and properly incorporate this design into the overall building design. Bracing indicated is to prevent buckling of individual truss web and/or chord members only. Additional temporary and permanent bracing is always required for stability and to prevent collapse with possible personal injury and property damage. For general guidance regarding the fabrication, storage, delivery, erection and bracing of trusses and truss systems, see **ANSI/TPI1 Quality Criteria and DSB-22** available from Truss Plate Institute (www.tpinst.org) and **BCSI Building Component Safety Information** available from the Structural Building Component Association (www.sbcacomponents.com)



818 Soundside Road
Edenton, NC 27932

Job 24020110	Truss A04	Truss Type Piggyback Base Structural Gable	Qty 1	Ply 1	DRB - 71 FaNC Job Reference (optional)	I63855452
-----------------	--------------	---	----------	----------	---	-----------

Carter Components (Sanford, NC), Sanford, NC - 27332,

Run: 8.63 S Nov 1 2023 Print: 8.630 S Nov 1 2023 MiTek Industries, Inc. Mon Feb 26 11:35:11
ID:2KeN4EJcNub9W0AiwJaYnXzypFP-RfC?PsB70Hq3NSgPqnL8w3ulTXbGKWrCDoi7J4zJC?f

Page: 2

- 13) N/A
 14) This truss is designed in accordance with the 2018 International Residential Code sections R502.11.1 and R802.10.2 and referenced standard ANSI/TPI 1.
 15) Graphical purlin representation does not depict the size or the orientation of the purlin along the top and/or bottom chord.
 16) N/A

LOAD CASE(S) Standard

WARNING - Verify design parameters and READ NOTES ON THIS AND INCLUDED MITEK REFERENCE PAGE MII-7473 rev. 1/2/2023 BEFORE USE.

Design valid for use only with MiTek® connectors. This design is based only upon parameters shown, and is for an individual building component, not a truss system. Before use, the building designer must verify the applicability of design parameters and properly incorporate this design into the overall building design. Bracing indicated is to prevent buckling of individual truss web and/or chord members only. Additional temporary and permanent bracing is always required for stability and to prevent collapse with possible personal injury and property damage. For general guidance regarding the fabrication, storage, delivery, erection and bracing of trusses and truss systems, see **ANSI/TPI1 Quality Criteria and DSB-22** available from Truss Plate Institute (www.tpinst.org) and **BCSI Building Component Safety Information** available from the Structural Building Component Association (www.sbcacomponents.com)



818 Soundside Road
Edenton, NC 27932

Job 24020110	Truss B01	Truss Type Common	Qty 4	Ply 1	DRB - 71 FaNC Job Reference (optional)	163855453
-----------------	--------------	----------------------	----------	----------	---	-----------

Carter Components (Sanford, NC), Sanford, NC - 27332,

Run: 8.63 S Nov 1 2023 Print: 8.630 S Nov 1 2023 MiTek Industries, Inc. Mon Feb 26 11:35:12
ID:W3FcQCIz8e0BDPmRU9iIhvzypEs-RfC?PsB70Hq3NSgPqnL8w3ulTXbGKwRCDoi7J4zJC?f

Page: 1

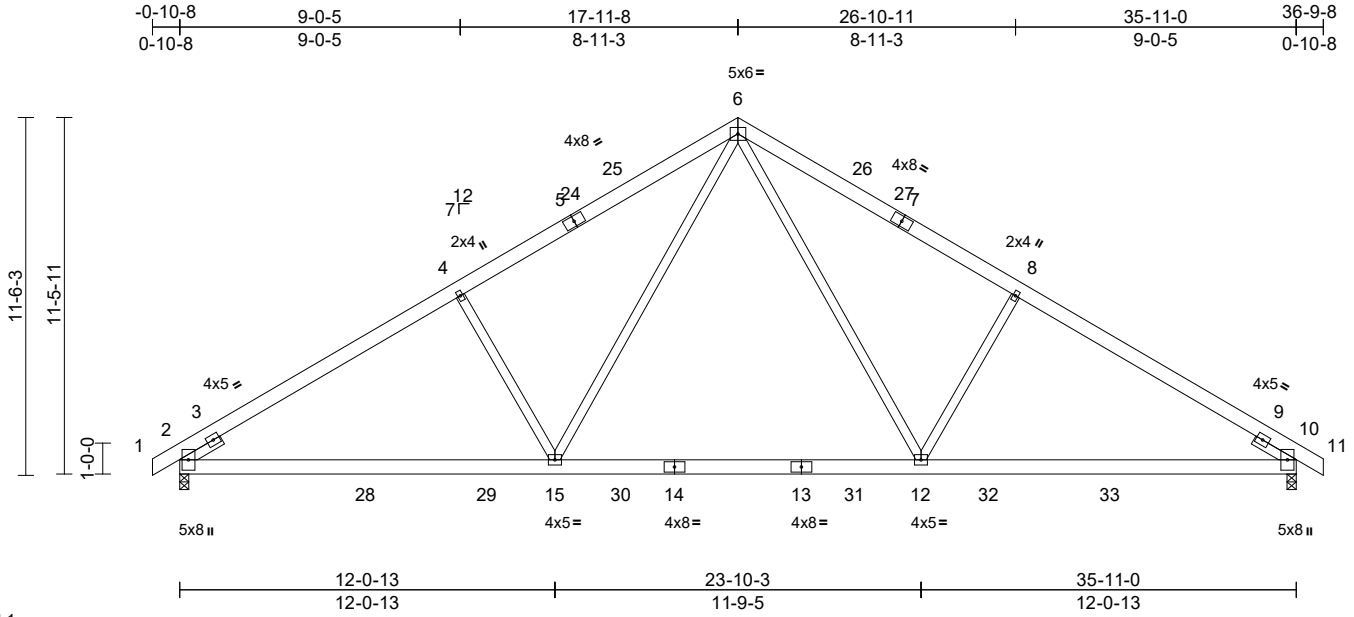

Scale = 1:74.1

Plate Offsets (X, Y): [2:0-4-2,0-0-14], [10:0-4-2,0-0-14]

Loading	(psf)	Spacing	2-0-0	CSI	DEFL	in	(loc)	l/defl	L/d	PLATES	GRIP	
TCLL (roof)	20.0	Plate Grip DOL	1.15	TC	0.78	Vert(LL)	-0.22	12-15	>999	240	MT20	244/190
Snow (Pf)	20.0	Lumber DOL	1.15	BC	0.80	Vert(CT)	-0.36	12-15	>999	180		
TCDL	10.0	Rep Stress Incr	YES	WB	0.42	Horz(CT)	0.06	10	n/a	n/a		
BCLL	0.0*	Code	IRC2018/TPI2014	Matrix-MSH								
BCDL	10.0											
											Weight: 245 lb	FT = 20%

LUMBER
TOP CHORD 2x6 SP No.2
BOT CHORD 2x6 SP No.2
WEBS 2x4 SP No.2 *Except* 4-15,8-12:2x4 SP No.3
SLIDER Left 2x4 SP No.3 -- 1-6-0, Right 2x4 SP No.3 -- 1-6-0

BRACING
TOP CHORD Structural wood sheathing directly applied or 3-3-12 oc purlins.
BOT CHORD Rigid ceiling directly applied or 10-0-0 oc bracing.

REACTIONS (size) 2=0-3-8, 10=0-3-8
Max Horiz 2=-258 (LC 12)
Max Uplift 2=-147 (LC 14), 10=-147 (LC 15)
Max Grav 2=1760 (LC 24), 10=1760 (LC 25)

FORCES (lb) - Maximum Compression/Maximum Tension
TOP CHORD 1-2=0/26, 2-4=-2473/233, 4-6=-2285/292, 6-8=-2285/292, 8-10=-2474/233, 10-11=0/26
BOT CHORD 2-15=-271/2220, 12-15=-17/1470, 10-12=-119/2027
WEBS 6-15=-153/1077, 6-12=-154/1077, 4-15=-524/311, 8-12=-524/311

NOTES
1) Unbalanced roof live loads have been considered for this design.
2) Wind: ASCE 7-16; Vult=130mph (3-second gust) Vasd=103mph; TCDL=6.0psf; BCDL=6.0psf; h=25ft; Cat. II; Exp B; Enclosed; MWFRS (envelope) exterior zone and C-C Exterior(2E) -0-10-8 to 2-8-10, Interior (1) 2-8-10 to 14-4-6, Exterior(2R) 14-4-6 to 21-6-10, Interior (1) 21-6-10 to 33-2-6, Exterior(2E) 33-2-6 to 36-9-8 zone; cantilever left and right exposed; end vertical left and right exposed; C-C for members and forces & MWFRS for reactions shown; Lumber DOL=1.60 plate grip DOL=1.60

- TCLL: ASCE 7-16; Pr=20.0 psf (roof LL: Lum DOL=1.15 Plate DOL=1.15); Pf=20.0 psf (Lum DOL=1.15 Plate DOL=1.15); Is=1.0; Rough Cat B; Fully Exp.; Ce=0.9; Cs=1.00; Ct=1.10
- Unbalanced snow loads have been considered for this design.
- This truss has been designed for greater of min roof live load of 12.0 psf or 1.00 times flat roof load of 20.0 psf on overhangs non-concurrent with other live loads.
- This truss has been designed for a 10.0 psf bottom chord live load nonconcurrent with any other live loads.
- * This truss has been designed for a live load of 20.0psf on the bottom chord in all areas where a rectangle 3-06-00 tall by 2-00-00 wide will fit between the bottom chord and any other members, with BCDL = 10.0psf.
- One H2.5A Simpson Strong-Tie connectors recommended to connect truss to bearing walls due to UPLIFT at jt(s) 2 and 10. This connection is for uplift only and does not consider lateral forces.
- This truss is designed in accordance with the 2018 International Residential Code sections R502.11.1 and R802.10.2 and referenced standard ANSI/TPI 1.

LOAD CASE(S) Standard



February 27, 2024

WARNING - Verify design parameters and READ NOTES ON THIS AND INCLUDED MITEK REFERENCE PAGE MII-7473 rev. 1/2/2023 BEFORE USE.

Design valid for use only with MiTek® connectors. This design is based only upon parameters shown, and is for an individual building component, not a truss system. Before use, the building designer must verify the applicability of design parameters and properly incorporate this design into the overall building design. Bracing indicated is to prevent buckling of individual truss web and/or chord members only. Additional temporary and permanent bracing is always required for stability and to prevent collapse with possible personal injury and property damage. For general guidance regarding the fabrication, storage, delivery, erection and bracing of trusses and truss systems, see **ANSI/TPI1 Quality Criteria and DSB-22** available from Truss Plate Institute (www.tpinst.org) and **BCSI Building Component Safety Information** available from the Structural Building Component Association (www.sbcacomponents.com)



818 Soundside Road
Edenton, NC 27932

Job 24020110	Truss B02	Truss Type Common Supported Gable	Qty 1	Ply 1	DRB - 71 FaNC Job Reference (optional)	163855454
-----------------	--------------	--------------------------------------	----------	----------	---	-----------

Carter Components (Sanford, NC), Sanford, NC - 27332,

Run: 8.63 S Nov 1 2023 Print: 8.630 S Nov 1 2023 MiTek Industries, Inc. Mon Feb 26 11:35:13
ID:EF0p5R3VnxPMyYwdZkH5HczpER-RfC?PsB70Hq3NSgPqnL8w3uTXbGKwRCDoi7J4zJC?f

Page: 1

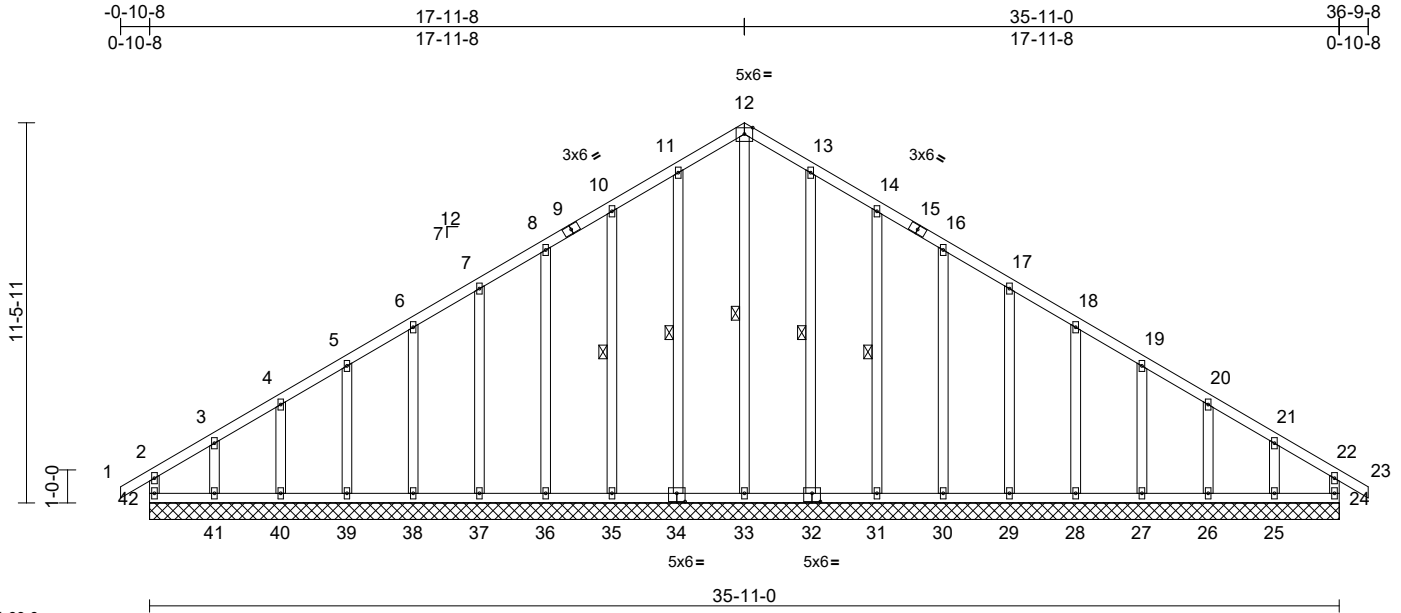

Scale = 1:69.6

Plate Offsets (X, Y): [32:0-3-0,0-3-0], [34:0-3-0,0-3-0]

Loading	(psf)	Spacing	1-11-4	CSI	DEFL	in	(loc)	l/defl	L/d	PLATES	GRIP	
TCLL (roof)	20.0	Plate Grip DOL	1.15	TC	0.20	Vert(LL)	n/a	-	n/a	999	MT20	244/190
Snow (Pf)	20.0	Lumber DOL	1.15	BC	0.10	Vert(CT)	n/a	-	n/a	999		
TCDL	10.0	Rep Stress Incr	YES	WB	0.15	Horz(CT)	0.01	24	n/a	n/a		
BCLL	0.0*	Code	IRC2018/TPI2014	Matrix-MR								
BCDL	10.0											
											Weight: 272 lb	FT = 20%

LUMBER

TOP CHORD	2x4 SP No.2
BOT CHORD	2x4 SP No.2
WEBS	2x4 SP No.3
OTHERS	2x4 SP No.3 *Except* 33-12:2x4 SP No.2

BRACING

TOP CHORD	Structural wood sheathing directly applied or 6-0-0 oc purlins, except end verticals.
BOT CHORD	Rigid ceiling directly applied or 6-0-0 oc bracing.
WEBS	1 Row at midpt 12-33, 11-34, 10-35, 13-32, 14-31

REACTIONS (size)

24=35-11-0, 25=35-11-0,
26=35-11-0, 27=35-11-0,
28=35-11-0, 29=35-11-0,
30=35-11-0, 31=35-11-0,
32=35-11-0, 33=35-11-0,
34=35-11-0, 35=35-11-0,
36=35-11-0, 37=35-11-0,
38=35-11-0, 39=35-11-0,
40=35-11-0, 41=35-11-0,
42=35-11-0
Max Horiz 42=275 (LC 12)
Max Uplift 24=68 (LC 11), 25=123 (LC 15),
26=32 (LC 15), 27=53 (LC 15),
28=48 (LC 15), 29=49 (LC 15),
30=47 (LC 15), 31=55 (LC 15),
32=37 (LC 15), 34=39 (LC 14),
35=55 (LC 14), 36=48 (LC 14),
37=49 (LC 14), 38=47 (LC 14),
39=54 (LC 14), 40=28 (LC 14),
41=140 (LC 14), 42=120 (LC 10)

Max Grav 24=175 (LC 24), 25=199 (LC 25),
26=159 (LC 22), 27=164 (LC 25),
28=161 (LC 25), 29=161 (LC 25),
30=168 (LC 22), 31=225 (LC 22),
32=242 (LC 22), 33=252 (LC 15),
34=242 (LC 21), 35=225 (LC 21),
36=168 (LC 21), 37=162 (LC 24),
38=160 (LC 24), 39=165 (LC 28),
40=159 (LC 21), 41=223 (LC 24),
42=216 (LC 25)

FORCES (lb) - Maximum Compression/Maximum Tension

TOP CHORD 2-42=-173/98, 1-2=0/30, 2-3=-200/187,
3-4=-152/145, 4-5=-145/145, 5-6=-130/149,
6-7=-117/176, 7-8=-104/204, 8-10=-130/238,
10-11=-157/286, 11-12=-181/325,
12-13=-181/325, 13-14=-157/286,
14-16=-130/238, 16-17=-104/194,
17-18=-78/148, 18-19=-74/119,
19-20=-88/92, 20-21=-98/91,
21-22=-139/124, 22-23=0/30, 22-24=-141/57

BOT CHORD 41-42=-116/133, 40-41=-116/133,
39-40=-116/133, 38-39=-116/133,
37-38=-116/133, 36-37=-116/133,
35-36=-116/133, 33-35=-116/133,
31-33=-117/134, 30-31=-117/134,
29-30=-117/134, 28-29=-117/134,
27-28=-117/134, 26-27=-117/134,
25-26=-117/134, 24-25=-117/134

WEBS 12-33=-264/91, 11-34=-204/62,
10-35=-186/78, 8-36=-130/71, 7-37=-123/72,
6-38=-122/71, 5-39=-124/74, 4-40=-120/65,
3-41=-151/120, 13-32=-204/61,
14-31=-186/78, 16-30=-130/71,
17-29=-123/72, 18-28=-122/72,
19-27=-123/74, 20-26=-120/64,
21-25=-138/111

- 1) Unbalanced roof live loads have been considered for this design.
- 2) Wind: ASCE 7-16; Vult=130mph (3-second gust) Vasd=103mph; TCDL=6.0psf; BCDL=6.0psf; h=25ft; Cat. II; Exp B; Enclosed; MWFRS (envelope) exterior zone and C-C Corner(3E) -0-10-8 to 2-8-10, Exterior (2N) 2-8-10 to 14-4-6, Corner(3R) 14-4-6 to 21-6-10, Exterior(2N) 21-6-10 to 33-2-6, Corner(3E) 33-2-6 to 36-9-8 zone; cantilever left and right exposed ; end vertical left and right exposed;C-C for members and forces & MWFRS for reactions shown; Lumber DOL=1.60 plate grip DOL=1.60
- 3) Truss designed for wind loads in the plane of the truss only. For studs exposed to wind (normal to the face), see Standard Industry Gable End Details as applicable, or consult qualified building designer as per ANSI/TPI 1.
- 4) TCLL: ASCE 7-16; Pr=20.0 psf (roof LL: Lum DOL=1.15) Plate DOL=1.15; Pf=20.0 psf (Lum DOL=1.15 Plate DOL=1.15); Is=1.0; Rough Cat B; Fully Exp.; Ce=0.9; Cs=1.00; Ct=1.10
- 5) Unbalanced snow loads have been considered for this design.

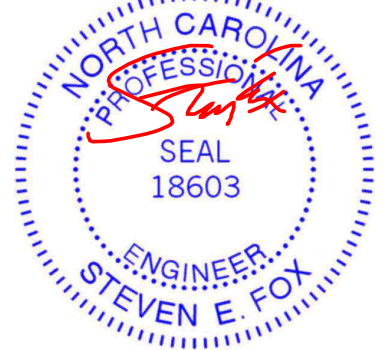

February 27, 2024

Continued on page 2

WARNING - Verify design parameters and READ NOTES ON THIS AND INCLUDED MITEK REFERENCE PAGE MII-7473 rev. 1/2/2023 BEFORE USE.

Design valid for use only with MiTek® connectors. This design is based only upon parameters shown, and is for an individual building component, not a truss system. Before use, the building designer must verify the applicability of design parameters and properly incorporate this design into the overall building design. Bracing indicated is to prevent buckling of individual truss web and/or chord members only. Additional temporary and permanent bracing is always required for stability and to prevent collapse with possible personal injury and property damage. For general guidance regarding the fabrication, storage, delivery, erection and bracing of trusses and truss systems, see **ANSI/TPI1 Quality Criteria and DSB-22** available from Truss Plate Institute (www.tpinst.org) and **BCSI Building Component Safety Information** available from the Structural Building Component Association (www.sbcacomponents.com)



818 Soundside Road
Edenton, NC 27932

Job 24020110	Truss B02	Truss Type Common Supported Gable	Qty 1	Ply 1	DRB - 71 FaNC Job Reference (optional)	I63855454
-----------------	--------------	--------------------------------------	----------	----------	---	-----------

Carter Components (Sanford, NC), Sanford, NC - 27332,

Run: 8.63 S Nov 1 2023 Print: 8.630 S Nov 1 2023 MiTek Industries, Inc. Mon Feb 26 11:35:13
ID:EF0p5R3VnxPMYywdZKh5HczypER-RfC?PsB70Hq3NSgPqnL8w3uTXbGKWrCDoi7J4zJC?f

Page: 2

- 6) This truss has been designed for greater of min roof live load of 12.0 psf or 1.00 times flat roof load of 20.0 psf on overhangs non-concurrent with other live loads.
- 7) All plates are 2x4 MT20 unless otherwise indicated.
- 8) Gable requires continuous bottom chord bearing.
- 9) Truss to be fully sheathed from one face or securely braced against lateral movement (i.e. diagonal web).
- 10) Gable studs spaced at 2-0-0 oc.
- 11) This truss has been designed for a 10.0 psf bottom chord live load nonconcurrent with any other live loads.
- 12) * This truss has been designed for a live load of 20.0psf on the bottom chord in all areas where a rectangle 3-06-00 tall by 2-00-00 wide will fit between the bottom chord and any other members.
- 13) Provide mechanical connection (by others) of truss to bearing plate capable of withstanding 120 lb uplift at joint 42, 68 lb uplift at joint 24, 39 lb uplift at joint 34, 55 lb uplift at joint 35, 48 lb uplift at joint 36, 49 lb uplift at joint 37, 47 lb uplift at joint 38, 54 lb uplift at joint 39, 28 lb uplift at joint 40, 140 lb uplift at joint 41, 37 lb uplift at joint 32, 55 lb uplift at joint 31, 47 lb uplift at joint 30, 49 lb uplift at joint 29, 48 lb uplift at joint 28, 53 lb uplift at joint 27, 32 lb uplift at joint 26 and 123 lb uplift at joint 25.
- 14) This truss is designed in accordance with the 2018 International Residential Code sections R502.11.1 and R802.10.2 and referenced standard ANSI/TPI 1.

LOAD CASE(S) Standard

WARNING - Verify design parameters and READ NOTES ON THIS AND INCLUDED MITEK REFERENCE PAGE MII-7473 rev. 1/2/2023 BEFORE USE.

Design valid for use only with MiTek® connectors. This design is based only upon parameters shown, and is for an individual building component, not a truss system. Before use, the building designer must verify the applicability of design parameters and properly incorporate this design into the overall building design. Bracing indicated is to prevent buckling of individual truss web and/or chord members only. Additional temporary and permanent bracing is always required for stability and to prevent collapse with possible personal injury and property damage. For general guidance regarding the fabrication, storage, delivery, erection and bracing of trusses and truss systems, see **ANSI/TPI1 Quality Criteria and DSB-22** available from Truss Plate Institute (www.tpinst.org) and **BCSI Building Component Safety Information** available from the Structural Building Component Association (www.sbcacomponents.com)



818 Soundside Road
Edenton, NC 27932

Job 24020110	Truss C01	Truss Type Monopitch	Qty 10	Ply 1	DRB - 71 FaNC Job Reference (optional)	163855455
-----------------	--------------	-------------------------	-----------	----------	---	-----------

Carter Components (Sanford, NC), Sanford, NC - 27332,

Run: 8.63 S Nov 1 2023 Print: 8.630 S Nov 1 2023 MiTek Industries, Inc. Mon Feb 26 11:35:13
ID:L1C9i0Rk9B5Z9DOJeE7VzypDz-RfC?PsB70Hq3NSgPqnL8w3ulTXbGKwRCDoi7J4zJC?f

Page: 1

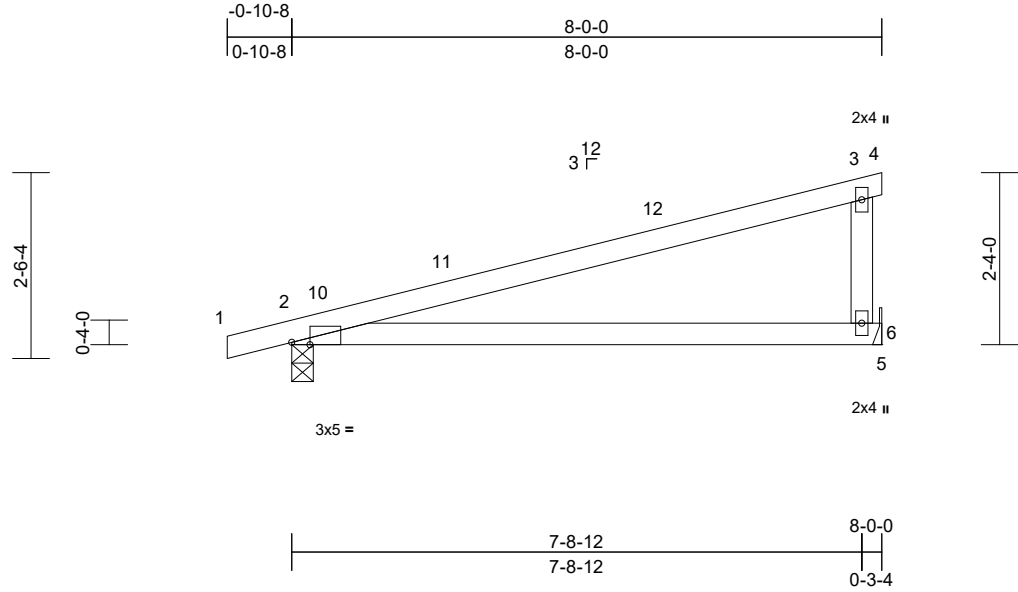

Scale = 1:31.2

Plate Offsets (X, Y): [2:0-2-15,Edge]

Loading	(psf)	Spacing	2-0-0	CSI	DEFL	in	(loc)	l/defl	L/d	PLATES	GRIP	
TCLL (roof)	20.0	Plate Grip DOL	1.15	TC	0.97	Vert(LL)	-0.25	6-9	>364	240	MT20	244/190
Snow (Pf)	20.0	Lumber DOL	1.15	BC	0.94	Vert(CT)	-0.45	6-9	>205	180		
TCDL	10.0	Rep Stress Incr	YES	WB	0.00	Horz(CT)	0.01	2	n/a	n/a		
BCLL	0.0*	Code	IRC2018/TPI2014	Matrix-MP								
BCDL	10.0											
											Weight: 28 lb	FT = 20%

LUMBER

TOP CHORD 2x4 SP No.1
BOT CHORD 2x4 SP No.2
WEBS 2x4 SP No.3

BRACING

TOP CHORD Structural wood sheathing directly applied, except end verticals.
BOT CHORD Rigid ceiling directly applied.

REACTIONS (size) 2=0-3-8, 6= Mechanical
Max Horiz 2=81 (LC 13)
Max Uplift 2=-78 (LC 10), 6=-55 (LC 14)
Max Grav 2=450 (LC 21), 6=432 (LC 21)

FORCES (lb) - Maximum Compression/Maximum Tension

TOP CHORD 1-2=0/13, 2-3=-304/74, 3-4=-6/0, 3-6=-311/177
BOT CHORD 2-6=-102/272, 5-6=0/0

NOTES

- 1) Wind: ASCE 7-16; Vult=130mph (3-second gust)
Vasd=103mph; TCDL=6.0psf; BCDL=6.0psf; h=25ft;
Cat. II; Exp B; Enclosed; MWFRS (envelope) exterior zone and C-C Exterior(2E) -0-10-8 to 2-1-8, Interior (1) 2-1-8 to 5-0-0, Exterior(2E) 5-0-0 to 8-0-0 zone; cantilever left and right exposed ; end vertical left and right exposed;C-C for members and forces & MWFRS for reactions shown; Lumber DOL=1.60 plate grip DOL=1.60
- 2) TCLL: ASCE 7-16; Pr=20.0 psf (roof LL: Lum DOL=1.15 Plate DOL=1.15); Pf=20.0 psf (Lum DOL=1.15 Plate DOL=1.15); Is=1.0; Rough Cat B; Fully Exp.; Ce=0.9; Cs=1.00; Ct=1.10
- 3) Unbalanced snow loads have been considered for this design.
- 4) This truss has been designed for greater of min roof live load of 12.0 psf or 1.00 times flat roof load of 20.0 psf on overhangs non-concurrent with other live loads.

- 5) This truss has been designed for a 10.0 psf bottom chord live load nonconcurrent with any other live loads.
- 6) * This truss has been designed for a live load of 20.0psf on the bottom chord in all areas where a rectangle 3-06-00 tall by 2-00-00 wide will fit between the bottom chord and any other members.
- 7) Refer to girder(s) for truss to truss connections.
- 8) Provide mechanical connection (by others) of truss to bearing plate capable of withstanding 55 lb uplift at joint 6.
- 9) One H2.5A Simpson Strong-Tie connectors recommended to connect truss to bearing walls due to UPLIFT at jt(s) 2. This connection is for uplift only and does not consider lateral forces.
- 10) This truss is designed in accordance with the 2018 International Residential Code sections R502.11.1 and R802.10.2 and referenced standard ANSI/TPI 1.

LOAD CASE(S) Standard

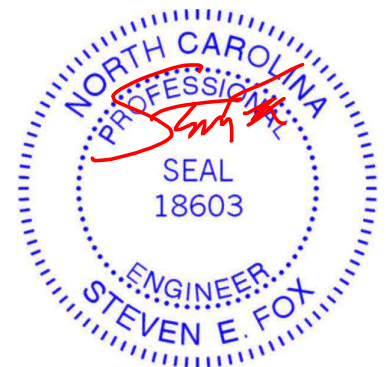

February 27, 2024

WARNING - Verify design parameters and READ NOTES ON THIS AND INCLUDED MITEK REFERENCE PAGE MII-7473 rev. 1/2/2023 BEFORE USE.

Design valid for use only with MiTek® connectors. This design is based only upon parameters shown, and is for an individual building component, not a truss system. Before use, the building designer must verify the applicability of design parameters and properly incorporate this design into the overall building design. Bracing indicated is to prevent buckling of individual truss web and/or chord members only. Additional temporary and permanent bracing is always required for stability and to prevent collapse with possible personal injury and property damage. For general guidance regarding the fabrication, storage, delivery, erection and bracing of trusses and truss systems, see **ANSI/TPI1 Quality Criteria and DSB-22** available from Truss Plate Institute (www.tpinst.org) and **BCSI Building Component Safety Information** available from the Structural Building Component Association (www.sbcacomponents.com)



818 Soundside Road
Edenton, NC 27932

Job 24020110	Truss C02	Truss Type Monopitch Supported Gable	Qty 2	Ply 1	DRB - 71 FaNC Job Reference (optional)	163855456
-----------------	--------------	---	----------	----------	---	-----------

Carter Components (Sanford, NC), Sanford, NC - 27332,

Run: 8.63 S Nov 1 2023 Print: 8.630 S Nov 1 2023 MiTek Industries, Inc. Mon Feb 26 11:35:13
ID:B?78iMB74HgN0u3L96IUJzypD4-RfC?PsB70Hq3NSgPqnL8w3uITxbGKWrCdoi7J4zJC?F

Page: 1

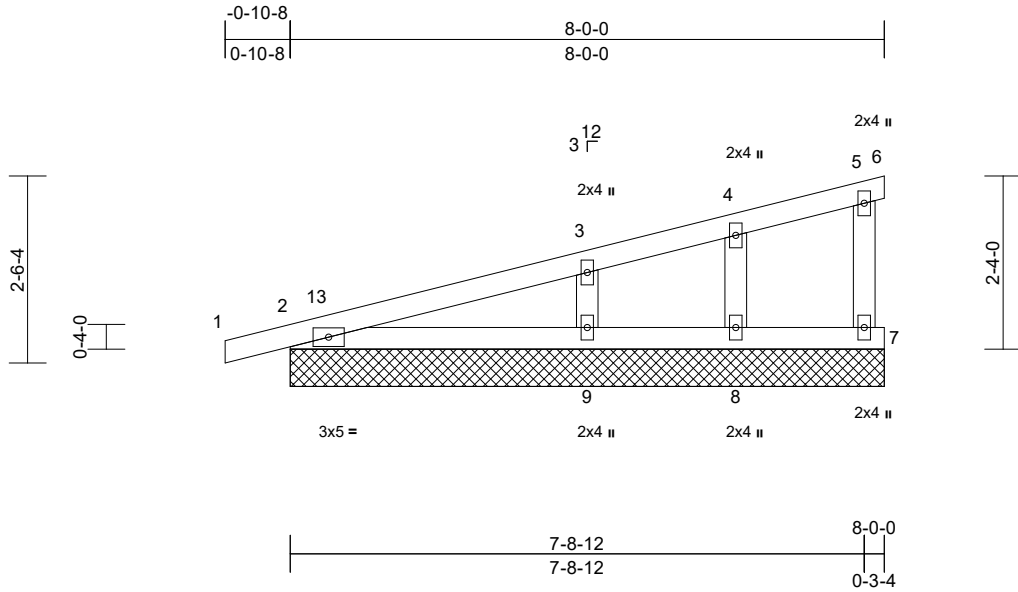

Scale = 1:31

Loading	(psf)	Spacing	1-11-4	CSI	DEFL	in	(loc)	l/defl	L/d	PLATES	GRIP	
TCLL (roof)	20.0	Plate Grip DOL	1.15	TC	0.19	Vert(LL)	n/a	-	n/a	999	MT20	244/190
Snow (Pf)	20.0	Lumber DOL	1.15	BC	0.19	Vert(CT)	n/a	-	n/a	999		
TCDL	10.0	Rep Stress Incr	YES	WB	0.06	Horz(CT)	0.00	2	n/a	n/a		
BCLL	0.0*	Code	IRC2018/TPI2014	Matrix-MP								
BCDL	10.0											
										Weight: 31 lb	FT = 20%	

LUMBER

TOP CHORD	2x4 SP No.2
BOT CHORD	2x4 SP No.2
WEBS	2x4 SP No.3
OTHERS	2x4 SP No.3

BRACING

TOP CHORD	Structural wood sheathing directly applied or 6-0-0 oc purlins, except end verticals.
BOT CHORD	Rigid ceiling directly applied or 10-0-0 oc bracing.

REACTIONS

(size)	2=8-0-0, 7=8-0-0, 8=8-0-0, 9=8-0-0, 10=8-0-0
Max Horiz	2=78 (LC 13), 10=78 (LC 13)
Max Uplift	2=-46 (LC 10), 7=-14 (LC 14), 8=-20 (LC 10), 9=-56 (LC 14), 10=-46 (LC 10)
Max Grav	2=215 (LC 21), 7=108 (LC 21), 8=126 (LC 21), 9=400 (LC 21), 10=215 (LC 21)

FORCES

(lb) - Maximum Compression/Maximum Tension	
TOP CHORD	1-2=0/12, 2-3=-92/77, 3-4=-43/49, 4-5=-33/43, 5-6=-5/0, 5-7=-88/38
BOT CHORD	2-9=-24/88, 8-9=-24/44, 7-8=-24/44
WEBS	3-9=-279/214, 4-8=-122/117

NOTES

- Wind: ASCE 7-16; Vult=130mph (3-second gust) Vasd=103mph; TCDL=6.0psf; BCDL=6.0psf; h=25ft; Cat. II; Exp B; Enclosed; MWFRS (envelope) exterior zone and C-C Corner(3E) -0-10-8 to 2-1-8, Exterior(2N) 2-1-8 to 5-0-0, Corner(3E) 5-0-0 to 8-0-0 zone; cantilever left and right exposed; end vertical left and right exposed; C-C for members and forces & MWFRS for reactions shown; Lumber DOL=1.60 plate grip DOL=1.60

- Truss designed for wind loads in the plane of the truss only. For studs exposed to wind (normal to the face), see Standard Industry Gable End Details as applicable, or consult qualified building designer as per ANSI/TPI 1.
- TCLL: ASCE 7-16; Pr=20.0 psf (roof LL: Lum DOL=1.15 Plate DOL=1.15); Pf=20.0 psf (Lum DOL=1.15 Plate DOL=1.15); Is=1.0; Rough Cat B; Fully Exp.; Ce=0.9; Cs=1.00; Ct=1.10
- Unbalanced snow loads have been considered for this design.
- This truss has been designed for greater of min roof live load of 12.0 psf or 1.00 times flat roof load of 20.0 psf on overhangs non-concurrent with other live loads.
- Gable requires continuous bottom chord bearing.
- Gable studs spaced at 2-0-0 oc.
- This truss has been designed for a 10.0 psf bottom chord live load nonconcurrent with any other live loads.
- * This truss has been designed for a live load of 20.0psf on the bottom chord in all areas where a rectangle 3-06-00 tall by 2-00-00 wide will fit between the bottom chord and any other members.
- Provide mechanical connection (by others) of truss to bearing plate capable of withstanding 46 lb uplift at joint 2, 14 lb uplift at joint 7, 56 lb uplift at joint 9, 20 lb uplift at joint 8 and 46 lb uplift at joint 2.
- This truss is designed in accordance with the 2018 International Residential Code sections R502.11.1 and R802.10.2 and referenced standard ANSI/TPI 1.

LOAD CASE(S) Standard

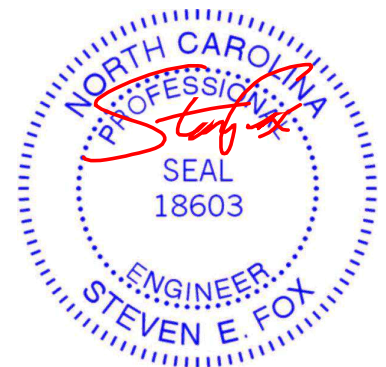

February 27, 2024

WARNING - Verify design parameters and READ NOTES ON THIS AND INCLUDED MITEK REFERENCE PAGE MII-7473 rev. 1/2/2023 BEFORE USE.

Design valid for use only with MiTek® connectors. This design is based only upon parameters shown, and is for an individual building component, not a truss system. Before use, the building designer must verify the applicability of design parameters and properly incorporate this design into the overall building design. Bracing indicated is to prevent buckling of individual truss web and/or chord members only. Additional temporary and permanent bracing is always required for stability and to prevent collapse with possible personal injury and property damage. For general guidance regarding the fabrication, storage, delivery, erection and bracing of trusses and truss systems, see **ANSI/TPI1 Quality Criteria and DSB-22** available from Truss Plate Institute (www.tpinst.org) and **BCSI Building Component Safety Information** available from the Structural Building Component Association (www.sbcacomponents.com)



818 Soundside Road
Edenton, NC 27932

Job 24020110	Truss C03	Truss Type Monopitch	Qty 4	Ply 1	DRB - 71 FaNC Job Reference (optional)	I63855457
-----------------	--------------	-------------------------	----------	----------	---	-----------

Carter Components (Sanford, NC), Sanford, NC - 27332,

Run: 8.63 S Nov 1 2023 Print: 8.630 S Nov 1 2023 MiTek Industries, Inc. Mon Feb 26 11:35:14
ID:Ut7CyCdodGXBJDiD3D_6TbrypCR-RfC?PsB70Hq3NSgPqnL8w3ulTXbGKWrCdoi7J4zJC?f

Page: 1

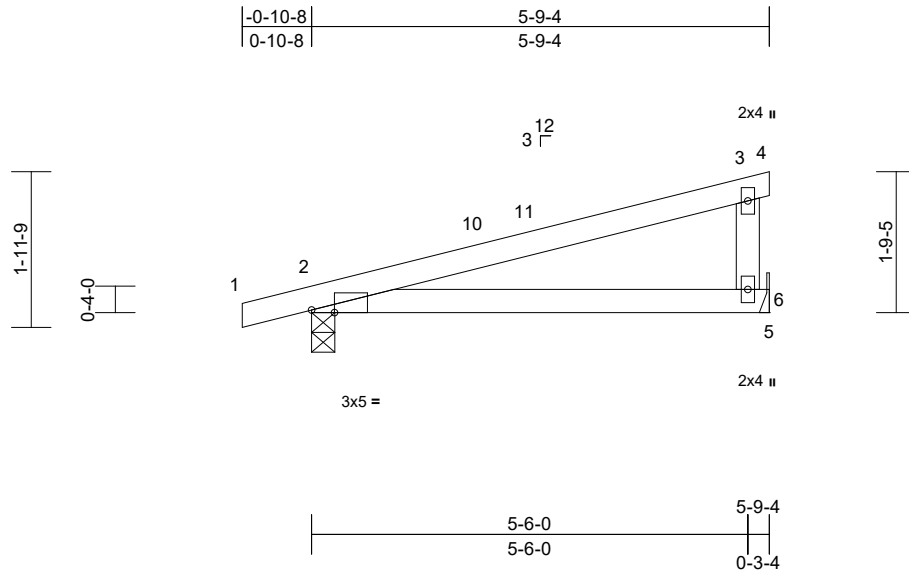

Scale = 1:29
Plate Offsets (X, Y): [2:0-3-7,Edge]

Loading	(psf)	Spacing	2-0-0	CSI	DEFL	in	(loc)	l/defl	L/d	PLATES	GRIP	
TCLL (roof)	20.0	Plate Grip DOL	1.15	TC	0.57	Vert(LL)	-0.07	6-9	>943	240	MT20	244/190
Snow (Pf)	20.0	Lumber DOL	1.15	BC	0.50	Vert(CT)	-0.12	6-9	>542	180		
TCDL	10.0	Rep Stress Incr	YES	WB	0.00	Horz(CT)	0.00	2	n/a	n/a		
BCLL	0.0*	Code	IRC2018/TPI2014	Matrix-MP								
BCDL	10.0											
											Weight: 21 lb	FT = 20%

LUMBER

TOP CHORD 2x4 SP No.2
BOT CHORD 2x4 SP No.2
WEBS 2x4 SP No.3

BRACING

TOP CHORD Structural wood sheathing directly applied or 5-9-4 oc purlins, except end verticals.
BOT CHORD Rigid ceiling directly applied or 10-0-0 oc bracing.

REACTIONS

(size) 2=0-3-8, 6= Mechanical
Max Horiz 2=59 (LC 13)
Max Uplift 2=-66 (LC 10), 6=-39 (LC 14)
Max Grav 2=369 (LC 21), 6=312 (LC 21)

FORCES

(lb) - Maximum Compression/Maximum Tension

TOP CHORD 1-2=0/18, 2-3=-183/53, 3-4=-6/0,
3-6=-220/140
BOT CHORD 2-6=-76/165, 5-6=0/0

NOTES

- 1) Wind: ASCE 7-16; Vult=130mph (3-second gust)
Vasd=103mph; TCDL=6.0psf; BCDL=6.0psf; h=25ft;
Cat. II; Exp B; Enclosed; MWFRS (envelope) exterior zone and C-C Exterior(2E) -0-10-8 to 2-1-8, Interior (1) 2-1-8 to 2-9-4, Exterior(2E) 2-9-4 to 5-9-4 zone; cantilever left and right exposed; end vertical left and right exposed; C-C for members and forces & MWFRS for reactions shown; Lumber DOL=1.60 plate grip DOL=1.60
- 2) TCLL: ASCE 7-16; Pr=20.0 psf (roof LL: Lum DOL=1.15 Plate DOL=1.15); Pf=20.0 psf (Lum DOL=1.15 Plate DOL=1.15); Is=1.0; Rough Cat B; Fully Exp.; Ce=0.9; Cs=1.00; Ct=1.10
- 3) Unbalanced snow loads have been considered for this design.
- 4) This truss has been designed for greater of min roof live load of 12.0 psf or 1.00 times flat roof load of 20.0 psf on overhangs non-concurrent with other live loads.

- 5) This truss has been designed for a 10.0 psf bottom chord live load nonconcurrent with any other live loads.
- 6) * This truss has been designed for a live load of 20.0psf on the bottom chord in all areas where a rectangle 3-06-00 tall by 2-00-00 wide will fit between the bottom chord and any other members.
- 7) Refer to girder(s) for truss to truss connections.
- 8) Provide mechanical connection (by others) of truss to bearing plate capable of withstanding 39 lb uplift at joint 6.
- 9) One H2.5A Simpson Strong-Tie connectors recommended to connect truss to bearing walls due to UPLIFT at jt(s) 2. This connection is for uplift only and does not consider lateral forces.
- 10) This truss is designed in accordance with the 2018 International Residential Code sections R502.11.1 and R802.10.2 and referenced standard ANSI/TPI 1.

LOAD CASE(S) Standard

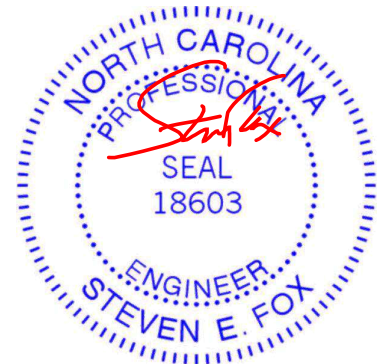

February 27, 2024

WARNING - Verify design parameters and READ NOTES ON THIS AND INCLUDED MITEK REFERENCE PAGE MII-7473 rev. 1/2/2023 BEFORE USE.

Design valid for use only with MiTek® connectors. This design is based only upon parameters shown, and is for an individual building component, not a truss system. Before use, the building designer must verify the applicability of design parameters and properly incorporate this design into the overall building design. Bracing indicated is to prevent buckling of individual truss web and/or chord members only. Additional temporary and permanent bracing is always required for stability and to prevent collapse with possible personal injury and property damage. For general guidance regarding the fabrication, storage, delivery, erection and bracing of trusses and truss systems, see **ANSI/TPI1 Quality Criteria and DSB-22** available from Truss Plate Institute (www.tpinst.org) and **BCSI Building Component Safety Information** available from the Structural Building Component Association (www.sbccomponents.com)



818 Soundside Road
Edenton, NC 27932

Job 24020110	Truss C04	Truss Type Monopitch Supported Gable	Qty 1	Ply 1	DRB - 71 FaNC Job Reference (optional)	163855458
-----------------	--------------	---	----------	----------	---	-----------

Carter Components (Sanford, NC), Sanford, NC - 27332,

Run: 8.63 S Nov 1 2023 Print: 8.630 S Nov 1 2023 MiTek Industries, Inc. Mon Feb 26 11:35:14
ID:Bpk_3dk3HLomWmT8eJASstizpCH-RfC?PsB70Hq3NSgPqnL8w3ulTXbGKWRcDoi7J4zJC?f

Page: 1

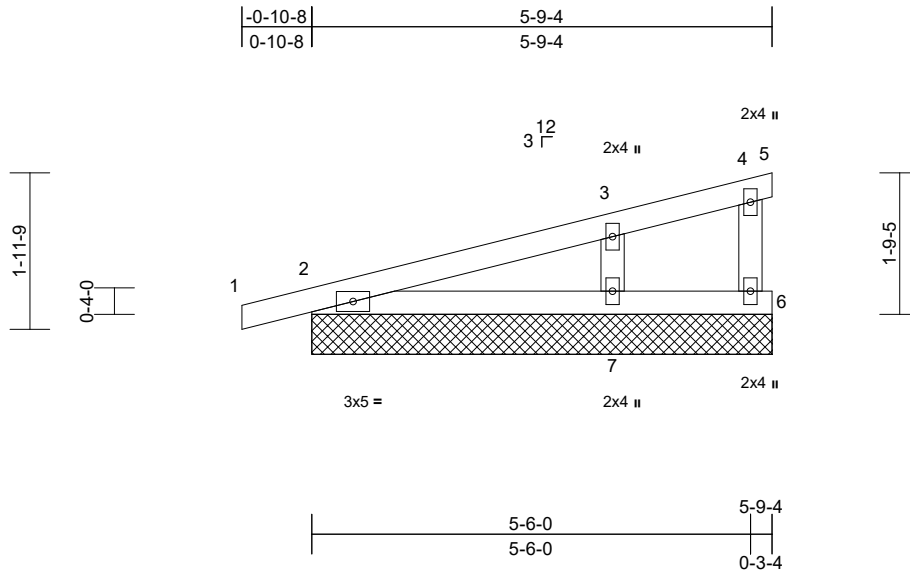

Loading	(psf)	Spacing	1-11-4	CSI	DEFL	in	(loc)	l/defl	L/d	PLATES	GRIP	
TCLL (roof)	20.0	Plate Grip DOL	1.15	TC	0.17	Vert(LL)	n/a	-	n/a	999	MT20	244/190
Snow (Pf)	20.0	Lumber DOL	1.15	BC	0.16	Vert(CT)	n/a	-	n/a	999		
TCDL	10.0	Rep Stress Incr	YES	WB	0.07	Horz(CT)	0.00	5	n/a	n/a		
BCLL	0.0*	Code	IRC2018/TPI2014	Matrix-MP								
BCDL	10.0											
											Weight: 22 lb	FT = 20%

LUMBER
TOP CHORD 2x4 SP No.2
BOT CHORD 2x4 SP No.2
WEBS 2x4 SP No.3
OTHERS 2x4 SP No.3

BRACING
TOP CHORD Structural wood sheathing directly applied or 5-9-4 oc purlins, except end verticals.
BOT CHORD Rigid ceiling directly applied or 10-0-0 oc bracing.

REACTIONS (size)
2=5-9-4, 5=5-9-4, 6=5-9-4, 7=5-9-4, 8=5-9-4
Max Horiz 2=57 (LC 11), 8=57 (LC 11)
Max Uplift 2=-49 (LC 10), 5=-2 (LC 14), 6=-12 (LC 7), 7=-52 (LC 14), 8=-49 (LC 10)
Max Grav 2=240 (LC 21), 5=32 (LC 21), 6=4 (LC 21), 7=378 (LC 21), 8=240 (LC 21)

FORCES (lb) - Maximum Compression/Maximum Tension
TOP CHORD 1-2=0/17, 2-3=-79/60, 3-4=-33/28, 4-5=-5/7, 4-6=-14/32
BOT CHORD 2-7=-22/82, 6-7=-17/32
WEBS 3-7=-268/243

- NOTES**
- Wind: ASCE 7-16; Vult=130mph (3-second gust)
Vasd=103mph; TCDL=6.0psf; BCDL=6.0psf; h=25ft;
Cat. II; Exp B; Enclosed; MWFRS (envelope) exterior zone and C-C Corner(3E) -0-10-8 to 2-1-8, Exterior(2N) 2-1-8 to 5-9-4 zone; cantilever left and right exposed; end vertical left and right exposed; C-C for members and forces & MWFRS for reactions shown; Lumber DOL=1.60 plate grip DOL=1.60
 - Truss designed for wind loads in the plane of the truss only. For studs exposed to wind (normal to the face), see Standard Industry Gable End Details as applicable, or consult qualified building designer as per ANSI/TPI 1.

- TCLL: ASCE 7-16; Pr=20.0 psf (roof LL: Lum DOL=1.15 Plate DOL=1.15); Pf=20.0 psf (Lum DOL=1.15 Plate DOL=1.15); Is=1.0; Rough Cat B; Fully Exp.; Ce=0.9; Cs=1.00; Ct=1.10
- Unbalanced snow loads have been considered for this design.
- This truss has been designed for greater of min roof live load of 12.0 psf or 1.00 times flat roof load of 20.0 psf on overhangs non-concurrent with other live loads.
- Gable requires continuous bottom chord bearing.
- Gable studs spaced at 2-0-0 oc.
- This truss has been designed for a 10.0 psf bottom chord live load nonconcurrent with any other live loads.
- * This truss has been designed for a live load of 20.0psf on the bottom chord in all areas where a rectangle 3-06-00 tall by 2-00-00 wide will fit between the bottom chord and any other members.
- Provide mechanical connection (by others) of truss to bearing plate capable of withstanding 49 lb uplift at joint 2, 2 lb uplift at joint 5, 12 lb uplift at joint 6, 52 lb uplift at joint 7 and 49 lb uplift at joint 2.
- Beveled plate or shim required to provide full bearing surface with truss chord at joint(s) 2, 8.
- This truss is designed in accordance with the 2018 International Residential Code sections R502.11.1 and R802.10.2 and referenced standard ANSI/TPI 1.

LOAD CASE(S) Standard

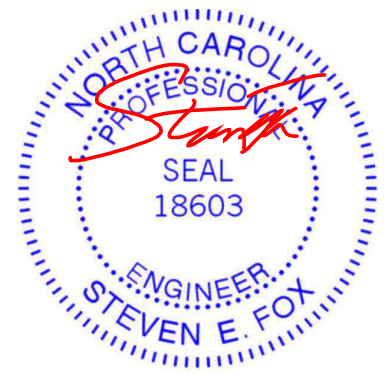

February 27, 2024

WARNING - Verify design parameters and READ NOTES ON THIS AND INCLUDED MITEK REFERENCE PAGE MII-7473 rev. 1/2/2023 BEFORE USE.
Design valid for use only with MiTek® connectors. This design is based only upon parameters shown, and is for an individual building component, not a truss system. Before use, the building designer must verify the applicability of design parameters and properly incorporate this design into the overall building design. Bracing indicated is to prevent buckling of individual truss web and/or chord members only. Additional temporary and permanent bracing is always required for stability and to prevent collapse with possible personal injury and property damage. For general guidance regarding the fabrication, storage, delivery, erection and bracing of trusses and truss systems, see **ANSI/TPI1 Quality Criteria and DSB-22** available from Truss Plate Institute (www.tpinst.org) and **BCSI Building Component Safety Information** available from the Structural Building Component Association (www.sbcacomponents.com)



818 Soundside Road
Edenton, NC 27932

Job 24020110	Truss D01	Truss Type Common	Qty 4	Ply 1	DRB - 71 FaNC Job Reference (optional)	163855459
-----------------	--------------	----------------------	----------	----------	---	-----------

Carter Components (Sanford, NC), Sanford, NC - 27332,

Run: 8.63 S Nov 1 2023 Print: 8.630 S Nov 1 2023 MiTek Industries, Inc. Mon Feb 26 11:35:14
ID:SpzxPUqXAaa15FKE92CMSzhHzI-RfC?PsB70Hq3NSgPqnL8w3ulTXbGKWrCDoi7J4zJC?F

Page: 1

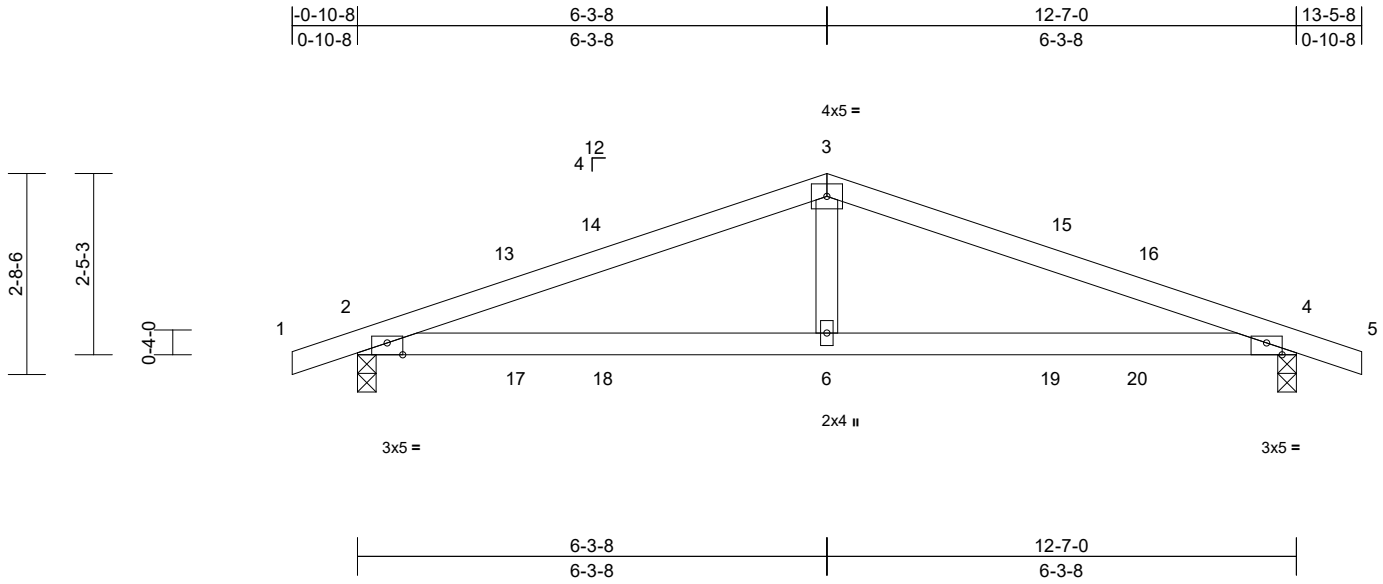

Scale = 1:30.9

Plate Offsets (X, Y): [2:0-2-8,Edge], [4:0-2-8,Edge]

Loading	(psf)	Spacing	2-0-0	CSI	DEFL	in	(loc)	l/defl	L/d	PLATES	GRIP	
TCLL (roof)	20.0	Plate Grip DOL	1.15	TC	0.73	Vert(LL)	0.13	6-12	>999	240	MT20	244/190
Snow (Pf)	20.0	Lumber DOL	1.15	BC	0.78	Vert(CT)	-0.16	6-12	>963	180		
TCDL	10.0	Rep Stress Incr	YES	WB	0.11	Horz(CT)	-0.02	4	n/a	n/a		
BCLL	0.0*	Code	IRC2018/TPI2014	Matrix-MSH								
BCDL	10.0											
											Weight: 44 lb	FT = 20%

LUMBER

TOP CHORD 2x4 SP No.2
BOT CHORD 2x4 SP No.2
WEBS 2x4 SP No.3

BRACING

TOP CHORD Structural wood sheathing directly applied or 3-9-12 oc purlins.
BOT CHORD Rigid ceiling directly applied or 5-0-10 oc bracing.

REACTIONS

(size) 2=0-3-0, 4=0-3-0
Max Horiz 2=38 (LC 14)
Max Uplift 2=-202 (LC 10), 4=-202 (LC 11)
Max Grav 2=649 (LC 21), 4=649 (LC 22)

FORCES

(lb) - Maximum Compression/Maximum Tension
TOP CHORD 1-2=0/17, 2-3=-968/1305, 3-4=-968/1305, 4-5=0/17
BOT CHORD 2-6=-1146/864, 4-6=-1146/864
WEBS 3-6=-496/291

NOTES

- Unbalanced roof live loads have been considered for this design.
- Wind: ASCE 7-16; Vult=130mph (3-second gust) Vasd=103mph; TCDL=6.0psf; BCDL=6.0psf; h=25ft; Cat. II; Exp B; Enclosed; MWFRS (envelope) exterior zone and C-C Exterior(2E) -0-10-8 to 2-1-8, Interior (1) 2-1-8 to 3-3-8, Exterior(2R) 3-3-8 to 9-3-8, Interior (1) 9-3-8 to 10-5-8, Exterior(2E) 10-5-8 to 13-5-8 zone; cantilever left and right exposed; end vertical left and right exposed; porch left and right exposed; C-C for members and forces & MWFRS for reactions shown; Lumber DOL=1.60 plate grip DOL=1.60
- TCLL: ASCE 7-16; Pr=20.0 psf (roof LL: Lum DOL=1.15 Plate DOL=1.15); Pf=20.0 psf (Lum DOL=1.15 Plate DOL=1.15); Is=1.0; Rough Cat B; Fully Exp.; Ce=0.9; Cs=1.00; Ct=1.10

- Unbalanced snow loads have been considered for this design.
- This truss has been designed for greater of min roof live load of 12.0 psf or 1.00 times flat roof load of 20.0 psf on overhangs non-concurrent with other live loads.
- This truss has been designed for a 10.0 psf bottom chord live load nonconcurrent with any other live loads.
- * This truss has been designed for a live load of 20.0psf on the bottom chord in all areas where a rectangle 3-06-00 tall by 2-00-00 wide will fit between the bottom chord and any other members.
- One H2.5A Simpson Strong-Tie connectors recommended to connect truss to bearing walls due to UPLIFT at jt(s) 2 and 4. This connection is for uplift only and does not consider lateral forces.
- This truss is designed in accordance with the 2018 International Residential Code sections R502.11.1 and R802.10.2 and referenced standard ANSI/TPI 1.

LOAD CASE(S) Standard

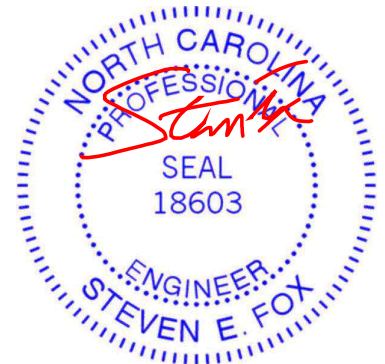

February 27, 2024

WARNING - Verify design parameters and READ NOTES ON THIS AND INCLUDED MITEK REFERENCE PAGE MII-7473 rev. 1/2/2023 BEFORE USE.

Design valid for use only with MiTek® connectors. This design is based only upon parameters shown, and is for an individual building component, not a truss system. Before use, the building designer must verify the applicability of design parameters and properly incorporate this design into the overall building design. Bracing indicated is to prevent buckling of individual truss web and/or chord members only. Additional temporary and permanent bracing is always required for stability and to prevent collapse with possible personal injury and property damage. For general guidance regarding the fabrication, storage, delivery, erection and bracing of trusses and truss systems, see **ANSI/TPI1 Quality Criteria and DSB-22** available from Truss Plate Institute (www.tpinst.org) and **BCSI Building Component Safety Information** available from the Structural Building Component Association (www.sbcacomponents.com)



818 Soundside Road
Edenton, NC 27932

Job 24020110	Truss D02	Truss Type Common Structural Gable	Qty 1	Ply 1	DRB - 71 FaNC Job Reference (optional)	163855460
-----------------	--------------	---------------------------------------	----------	----------	---	-----------

Carter Components (Sanford, NC), Sanford, NC - 27332,

Run: 8.63 S Nov 1 2023 Print: 8.630 S Nov 1 2023 MiTek Industries, Inc. Mon Feb 26 11:35:14
ID:OwXIGMdQ3ZhiPobRsWGHFHzhHzx-RfC?PsB70Hq3NSgPqnL8w3uITXbGKwRCDoi7J4zJC?f

Page: 1

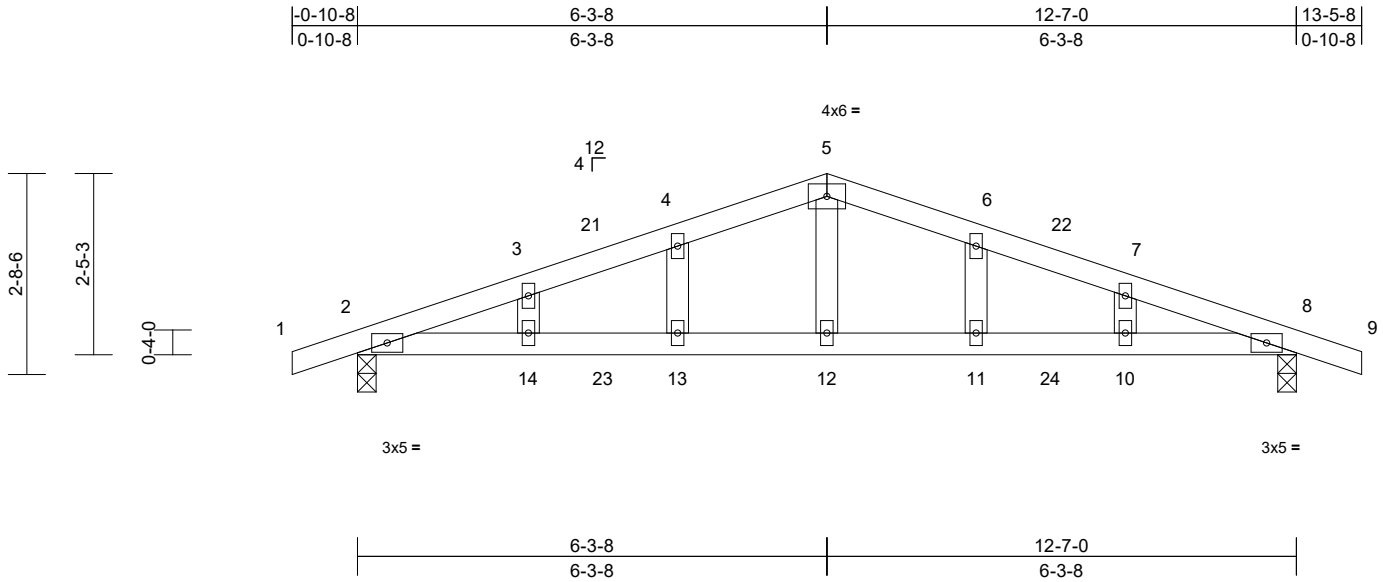

Scale = 1:30.9

Loading	(psf)	Spacing	1-11-4	CSI	DEFL	in	(loc)	l/defl	L/d	PLATES	GRIP	
TCLL (roof)	20.0	Plate Grip DOL	1.15	TC	0.46	Vert(LL)	0.13	10-11	>999	240	MT20	244/190
Snow (Pf)	20.0	Lumber DOL	1.15	BC	0.67	Vert(CT)	-0.17	10-11	>871	180		
TCDL	10.0	Rep Stress Incr	YES	WB	0.13	Horz(CT)	-0.02	8	n/a	n/a		
BCLL	0.0*	Code	IRC2018/TPI2014	Matrix-MSH								
BCDL	10.0											
											Weight: 49 lb	FT = 20%

LUMBER	
TOP CHORD	2x4 SP No.2
BOT CHORD	2x4 SP No.2
WEBS	2x4 SP No.3
OTHERS	2x4 SP No.3

BRACING	
TOP CHORD	Structural wood sheathing directly applied or 5-2-10 oc purlins.
BOT CHORD	Rigid ceiling directly applied or 4-9-7 oc bracing.

REACTIONS	
(size)	2=0-3-0, 8=0-3-0
Max Horiz	2=37 (LC 18)
Max Uplift	2=-196 (LC 10), 8=-196 (LC 11)
Max Grav	2=629 (LC 21), 8=629 (LC 22)

FORCES	
(lb) - Maximum Compression/Maximum Tension	
TOP CHORD	1-2=0/16, 2-3=-942/1277, 3-4=-917/1277, 4-5=-903/1298, 5-6=-903/1298, 6-7=-917/1277, 7-8=-942/1277, 8-9=0/16
BOT CHORD	2-14=-1138/860, 13-14=-1138/860, 12-13=-1138/860, 11-12=-1138/860, 10-11=-1138/860, 8-10=-1138/860
WEBS	5-12=-521/309, 4-13=-109/46, 3-14=-53/34, 6-11=-109/47, 7-10=-53/34

- NOTES**
- Unbalanced roof live loads have been considered for this design.
 - Wind: ASCE 7-16; Vult=130mph (3-second gust) Vasd=103mph; TCDL=6.0psf; BCDL=6.0psf; h=25ft; Cat. II; Exp B; Enclosed; MWFRS (envelope) exterior zone and C-C Exterior(2E) -0-10-8 to 2-3-8, Interior (1) 2-3-8 to 3-3-8, Exterior(2R) 3-3-8 to 9-3-8, Interior (1) 9-3-8 to 10-3-8, Exterior(2E) 10-3-8 to 13-5-8 zone; cantilever left and right exposed; end vertical left and right exposed; porch left and right exposed; C-C for members and forces & MWFRS for reactions shown; Lumber DOL=1.60 plate grip DOL=1.60

- Truss designed for wind loads in the plane of the truss only. For studs exposed to wind (normal to the face), see Standard Industry Gable End Details as applicable, or consult qualified building designer as per ANSI/TPI 1.
- TCLL: ASCE 7-16; Pr=20.0 psf (roof LL: Lum DOL=1.15 Plate DOL=1.15); Pf=20.0 psf (Lum DOL=1.15 Plate DOL=1.15); Is=1.0; Rough Cat B; Fully Exp.; Ce=0.9; Cs=1.00; Ct=1.10
- Unbalanced snow loads have been considered for this design.
- This truss has been designed for greater of min roof live load of 12.0 psf or 1.00 times flat roof load of 20.0 psf on overhangs non-concurrent with other live loads.
- All plates are 2x4 MT20 unless otherwise indicated.
- Gable studs spaced at 2-0-0 oc.
- This truss has been designed for a 10.0 psf bottom chord live load nonconcurrent with any other live loads.
- * This truss has been designed for a live load of 20.0psf on the bottom chord in all areas where a rectangle 3-06-00 tall by 2-00-00 wide will fit between the bottom chord and any other members.
- One H2.5A Simpson Strong-Tie connectors recommended to connect truss to bearing walls due to UPLIFT at jt(s) 2 and 8. This connection is for uplift only and does not consider lateral forces.
- This truss is designed in accordance with the 2018 International Residential Code sections R502.11.1 and R802.10.2 and referenced standard ANSI/TPI 1.

LOAD CASE(S) Standard



February 27, 2024

WARNING - Verify design parameters and READ NOTES ON THIS AND INCLUDED MITEK REFERENCE PAGE MII-7473 rev. 1/2/2023 BEFORE USE.

Design valid for use only with MiTek® connectors. This design is based only upon parameters shown, and is for an individual building component, not a truss system. Before use, the building designer must verify the applicability of design parameters and properly incorporate this design into the overall building design. Bracing indicated is to prevent buckling of individual truss web and/or chord members only. Additional temporary and permanent bracing is always required for stability and to prevent collapse with possible personal injury and property damage. For general guidance regarding the fabrication, storage, delivery, erection and bracing of trusses and truss systems, see **ANSI/TPI1 Quality Criteria and DSB-22** available from Truss Plate Institute (www.tpinst.org) and **BCSI Building Component Safety Information** available from the Structural Building Component Association (www.sbcacomponents.com)



818 Soundside Road
Edenton, NC 27932

Job 24020110	Truss F01	Truss Type Floor	Qty 5	Ply 1	DRB - 71 FaNC Job Reference (optional)	163855461
-----------------	--------------	---------------------	----------	----------	---	-----------

Carter Components (Sanford, NC), Sanford, NC - 27332,

Run: 8.63 S Nov 1 2023 Print: 8.630 S Nov 1 2023 MiTek Industries, Inc. Mon Feb 26 11:35:15
ID:OCrecDxPXX19myk2T7iUyAznBd4-RfC?PsB70Hq3NSgPqnL8w3ulTXbGKWrCDoi7J4zJC?F

Page: 1

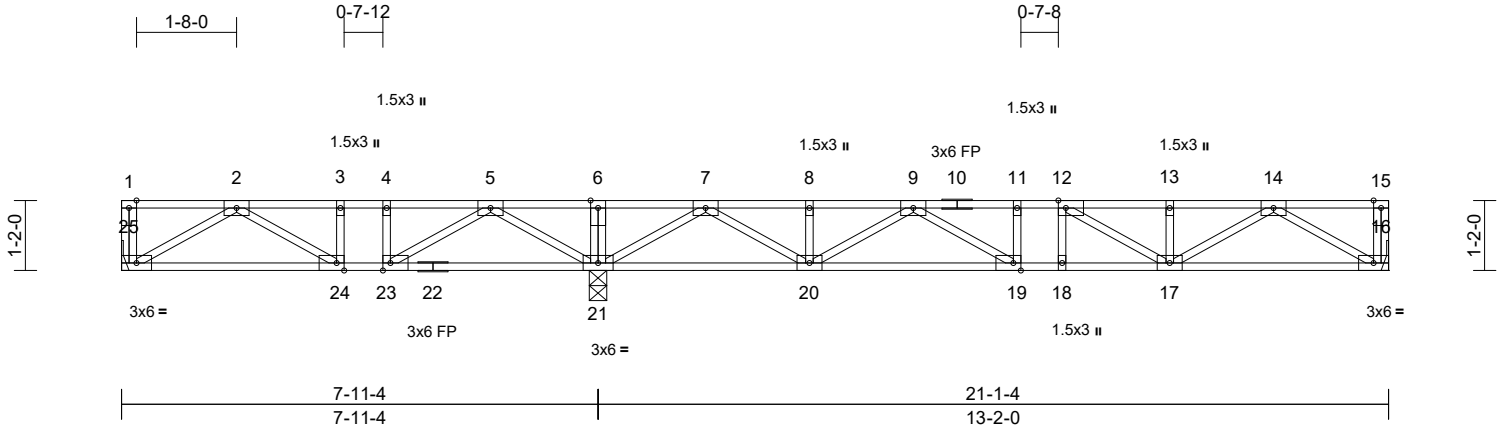

Scale = 1:38.4

Plate Offsets (X, Y): [12:0-1-8,Edge], [19:0-1-8,Edge], [23:0-1-8,Edge], [24:0-1-8,Edge]

Loading	(psf)	Spacing	1-4-0	CSI	DEFL	in	(loc)	l/defl	L/d	PLATES	GRIP	
TCLL	40.0	Plate Grip DOL	1.00	TC	0.37	Vert(LL)	-0.05	19	>999	480	MT20	244/190
TCDL	10.0	Lumber DOL	1.00	BC	0.32	Vert(CT)	-0.07	19-20	>999	360		
BCLL	0.0	Rep Stress Incr	YES	WB	0.33	Horz(CT)	0.01	16	n/a	n/a		
BCDL	5.0	Code	IRC2018/TPI2014	Matrix-MSH							Weight: 110 lb	FT = 20%F, 11%E

LUMBER
TOP CHORD 2x4 SP No.2(flat)
BOT CHORD 2x4 SP No.2(flat)
WEBS 2x4 SP No.3(flat)

BRACING
TOP CHORD Structural wood sheathing directly applied or 6-0-0 oc purlins, except end verticals.
BOT CHORD Rigid ceiling directly applied or 6-0-0 oc bracing.

REACTIONS (size) 16= Mechanical, 21=0-3-8, 25= Mechanical
Max Uplift 25=30 (LC 4)
Max Grav 16=413 (LC 4), 21=963 (LC 1), 25=237 (LC 3)

FORCES (lb) - Maximum Compression/Maximum Tension
TOP CHORD 1-25=-46/0, 15-16=-49/0, 1-2=0/0, 2-3=-359/251, 3-4=-359/251, 4-5=-359/251, 5-6=0/893, 6-7=0/893, 7-8=-606/0, 8-9=-606/0, 9-11=-1120/0, 11-12=-1120/0, 12-13=-979/0, 13-14=-979/0, 14-15=0/0
BOT CHORD 24-25=-84/309, 23-24=-251/359, 21-23=-523/107, 20-21=-157/22, 19-20=0/964, 18-19=0/1120, 17-18=0/1120, 16-17=0/609
WEBS 6-21=-138/0, 5-21=-660/0, 2-25=-357/97, 5-23=0/473, 2-24=-195/59, 3-24=-29/80, 4-23=-188/0, 7-21=-940/0, 14-16=-705/0, 7-20=0/702, 14-17=0/432, 8-20=-115/0, 13-17=-132/0, 9-20=-436/0, 12-17=-229/40, 9-19=0/288, 11-19=-83/0, 12-18=-56/36

- 4) Provide mechanical connection (by others) of truss to bearing plate capable of withstanding 30 lb uplift at joint 25.
 - 5) This truss is designed in accordance with the 2018 International Residential Code sections R502.11.1 and R802.10.2 and referenced standard ANSI/TPI 1.
 - 6) Recommend 2x6 strongbacks, on edge, spaced at 10-00-00 oc and fastened to each truss with 3-10d (0.131" X 3") nails. Strongbacks to be attached to walls at their outer ends or restrained by other means.
 - 7) CAUTION, Do not erect truss backwards.
- LOAD CASE(S)** Standard

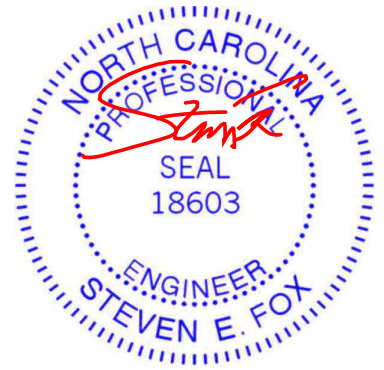

February 27, 2024

WARNING - Verify design parameters and READ NOTES ON THIS AND INCLUDED MITEK REFERENCE PAGE MII-7473 rev. 1/2/2023 BEFORE USE.

Design valid for use only with MiTek® connectors. This design is based only upon parameters shown, and is for an individual building component, not a truss system. Before use, the building designer must verify the applicability of design parameters and properly incorporate this design into the overall building design. Bracing indicated is to prevent buckling of individual truss web and/or chord members only. Additional temporary and permanent bracing is always required for stability and to prevent collapse with possible personal injury and property damage. For general guidance regarding the fabrication, storage, delivery, erection and bracing of trusses and truss systems, see **ANSI/TPI1 Quality Criteria and DSB-22** available from Truss Plate Institute (www.tpinst.org) and **BCSI Building Component Safety Information** available from the Structural Building Component Association (www.sbcacomponents.com)



818 Soundside Road
Edenton, NC 27932

Job 24020110	Truss F02	Truss Type Floor	Qty 10	Ply 1	DRB - 71 FaNC Job Reference (optional)	163855462
-----------------	--------------	---------------------	-----------	----------	---	-----------

Carter Components (Sanford, NC), Sanford, NC - 27332,

Run: 8.63 S Nov 1 2023 Print: 8.630 S Nov 1 2023 MiTek Industries, Inc. Mon Feb 26 11:35:15
ID:o22Co2BypgZJA0FueK3AmNznBcm-RfC?PsB70Hq3NSgPqnL8w3uITXbGKWrCDoi7J4zJC?f

Page: 1

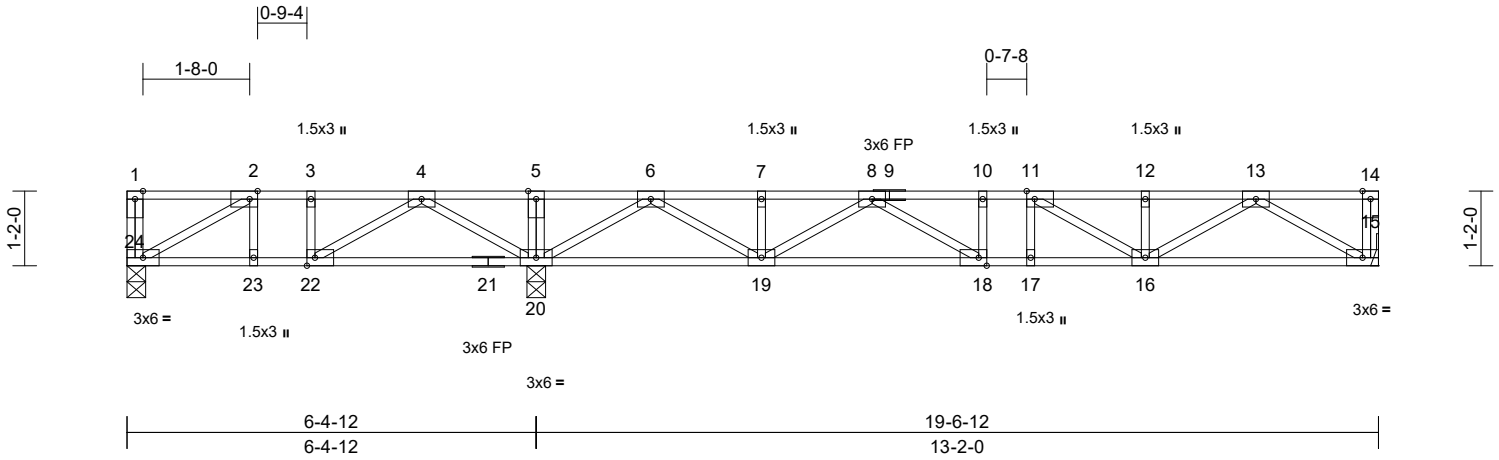

Scale = 1:36

Plate Offsets (X, Y): [2:0-1-8,Edge], [11:0-1-8,Edge], [18:0-1-8,Edge], [22:0-1-8,Edge]

Loading	(psf)	Spacing	1-4-0	CSI	DEFL	in	(loc)	l/defl	L/d	PLATES	GRIP	
TCLL	40.0	Plate Grip DOL	1.00	TC	0.36	Vert(LL)	-0.05	18	>999	480	MT20	244/190
TCDL	10.0	Lumber DOL	1.00	BC	0.32	Vert(CT)	-0.07	18-19	>999	360		
BCLL	0.0	Rep Stress Incr	YES	WB	0.33	Horz(CT)	0.01	15	n/a	n/a		
BCDL	5.0	Code	IRC2018/TPI2014	Matrix-MSH							Weight: 103 lb	FT = 20%F, 11%E

LUMBER

TOP CHORD 2x4 SP No.2(flat)
BOT CHORD 2x4 SP No.2(flat)
WEBS 2x4 SP No.3(flat)

BRACING

TOP CHORD Structural wood sheathing directly applied or 6-0-0 oc purlins, except end verticals.
BOT CHORD Rigid ceiling directly applied or 6-0-0 oc bracing.

REACTIONS

(size) 15= Mechanical, 20=0-3-8, 24=0-3-8
Max Uplift 24=65 (LC 4)
Max Grav 15=417 (LC 7), 20=922 (LC 1), 24=173 (LC 3)

FORCES

(lb) - Maximum Compression/Maximum Tension

TOP CHORD 1-24=-68/0, 14-15=-49/0, 1-2=0/0, 2-3=-203/193, 3-4=-203/193, 4-5=0/865, 5-6=0/865, 6-7=-643/0, 7-8=-643/0, 8-10=-1142/0, 10-11=-1142/0, 11-12=-992/0, 12-13=-992/0, 13-14=0/0
BOT CHORD 23-24=-193/203, 22-23=-193/203, 20-22=-476/52, 19-20=-124/65, 18-19=0/995, 17-18=0/1142, 16-17=0/1142, 15-16=0/616
WEBS 5-20=-135/0, 4-20=-591/0, 2-24=-233/221, 4-22=0/399, 2-23=-69/3, 3-22=-141/0, 6-20=-936/0, 13-15=-713/0, 6-19=0/696, 13-16=0/439, 7-19=-114/0, 12-16=-132/0, 8-19=-432/0, 11-16=-240/32, 8-18=0/282, 10-18=-81/0, 11-17=-54/38

NOTES

- Unbalanced floor live loads have been considered for this design.
- All plates are 3x5 MT20 unless otherwise indicated.
- Refer to girder(s) for truss to truss connections.

- One H2.5A Simpson Strong-Tie connectors recommended to connect truss to bearing walls due to UPLIFT at jt(s) 24. This connection is for uplift only and does not consider lateral forces.
- This truss is designed in accordance with the 2018 International Residential Code sections R502.11.1 and R802.10.2 and referenced standard ANSI/TPI 1.
- Recommend 2x6 strongbacks, on edge, spaced at 10-00-00 oc and fastened to each truss with 3-10d (0.131" X 3") nails. Strongbacks to be attached to walls at their outer ends or restrained by other means.
- CAUTION, Do not erect truss backwards.

LOAD CASE(S) Standard

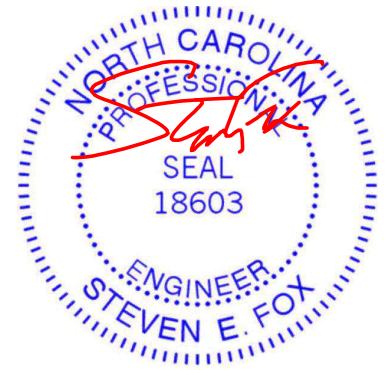

February 27, 2024

WARNING - Verify design parameters and READ NOTES ON THIS AND INCLUDED MITEK REFERENCE PAGE MII-7473 rev. 1/2/2023 BEFORE USE.

Design valid for use only with MiTek® connectors. This design is based only upon parameters shown, and is for an individual building component, not a truss system. Before use, the building designer must verify the applicability of design parameters and properly incorporate this design into the overall building design. Bracing indicated is to prevent buckling of individual truss web and/or chord members only. Additional temporary and permanent bracing is always required for stability and to prevent collapse with possible personal injury and property damage. For general guidance regarding the fabrication, storage, delivery, erection and bracing of trusses and truss systems, see **ANSI/TPI1 Quality Criteria and DSB-22** available from Truss Plate Institute (www.tpinst.org) and **BCSI Building Component Safety Information** available from the Structural Building Component Association (www.sbcacomponents.com)



818 Soundside Road
Edenton, NC 27932

Job 24020110	Truss F03	Truss Type Floor	Qty 10	Ply 1	DRB - 71 FaNC Job Reference (optional)	163855463
-----------------	--------------	---------------------	-----------	----------	---	-----------

Carter Components (Sanford, NC), Sanford, NC - 27332,

Run: 8.63 S Nov 1 2023 Print: 8.630 S Nov 1 2023 MiTek Industries, Inc. Mon Feb 26 11:35:15
ID:5fVGrGT?92av2i5V2MVpkRznBcO-RfC?PsB70Hq3NSgPqnL8w3ulTXbGkWrCDoi7J4zJC?f

Page: 1

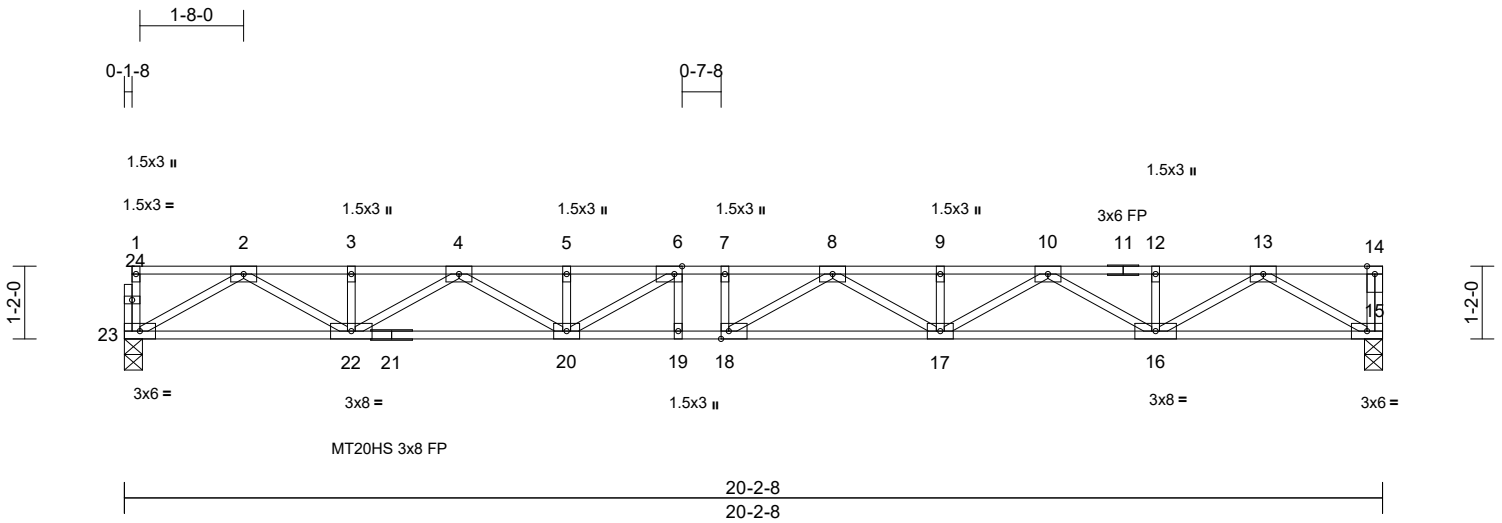

Scale = 1:37

Plate Offsets (X, Y): [6:0-1-8,Edge], [18:0-1-8,Edge]

Loading	(psf)	Spacing	1-4-0	CSI	DEFL	in	(loc)	l/defl	L/d	PLATES	GRIP	
TCLL	40.0	Plate Grip DOL	1.00	TC	0.37	Vert(LL)	-0.34	17-18	>705	480	MT20HS	187/143
TCDL	10.0	Lumber DOL	1.00	BC	0.73	Vert(CT)	-0.47	17-18	>509	360	MT20	244/190
BCLL	0.0	Rep Stress Incr	YES	WB	0.50	Horz(CT)	0.07	15	n/a	n/a		
BCLD	5.0	Code	IRC2018/TPI2014	Matrix-MSH								
											Weight: 104 lb	FT = 20%F, 11%E

LUMBER

TOP CHORD 2x4 SP No.2(flat)
 BOT CHORD 2x4 SP No.2(flat) *Except* 21-15:2x4 SP No.1(flat)
 WEBS 2x4 SP No.3(flat)
 OTHERS 2x4 SP No.3(flat)

5) Recommend 2x6 strongbacks, on edge, spaced at 10-00-00 oc and fastened to each truss with 3-10d (0.131" X 3") nails. Strongbacks to be attached to walls at their outer ends or restrained by other means.
 6) CAUTION, Do not erect truss backwards.

LOAD CASE(S) Standard

BRACING

TOP CHORD Structural wood sheathing directly applied or 6-0-0 oc purlins, except end verticals.
 BOT CHORD Rigid ceiling directly applied or 10-0-0 oc bracing.

REACTIONS (size) 15=0-3-8, 23=0-3-8
 Max Grav 15=732 (LC 1), 23=728 (LC 1)

FORCES (lb) - Maximum Compression/Maximum Tension
 TOP CHORD 1-23=-48/0, 14-15=-49/0, 1-2=-3/0, 2-3=-2049/0, 3-4=-2049/0, 4-5=-3187/0, 5-6=-3187/0, 6-7=-3474/0, 7-8=-3474/0, 8-9=-3193/0, 9-10=-3193/0, 10-12=-2047/0, 12-13=-2047/0, 13-14=0/0
 BOT CHORD 22-23=0/1154, 20-22=0/2718, 19-20=0/3474, 18-19=0/3474, 17-18=0/3446, 16-17=0/2720, 15-16=0/1155
 WEBS 13-15=-1336/0, 2-23=-1332/0, 13-16=0/1041, 2-22=0/1045, 12-16=-107/0, 3-22=-111/0, 10-16=-786/0, 4-22=-780/0, 10-17=0/552, 4-20=0/548, 9-17=-106/0, 5-20=-135/9, 8-17=-309/0, 6-20=-508/42, 8-18=-210/292, 6-19=-58/106, 7-18=-81/36

NOTES

- 1) Unbalanced floor live loads have been considered for this design.
- 2) All plates are MT20 plates unless otherwise indicated.
- 3) All plates are 3x5 MT20 unless otherwise indicated.
- 4) This truss is designed in accordance with the 2018 International Residential Code sections R502.11.1 and R802.10.2 and referenced standard ANSI/TPI 1.

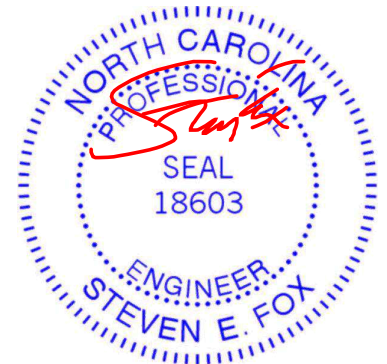

February 27, 2024

WARNING - Verify design parameters and READ NOTES ON THIS AND INCLUDED MITEK REFERENCE PAGE MII-7473 rev. 1/2/2023 BEFORE USE.

Design valid for use only with MiTek® connectors. This design is based only upon parameters shown, and is for an individual building component, not a truss system. Before use, the building designer must verify the applicability of design parameters and properly incorporate this design into the overall building design. Bracing indicated is to prevent buckling of individual truss web and/or chord members only. Additional temporary and permanent bracing is always required for stability and to prevent collapse with possible personal injury and property damage. For general guidance regarding the fabrication, storage, delivery, erection and bracing of trusses and truss systems, see **ANSI/TPI1 Quality Criteria and DSB-22** available from Truss Plate Institute (www.tpinst.org) and **BCSI Building Component Safety Information** available from the Structural Building Component Association (www.sbcacomponents.com)



818 Soundside Road
 Edenton, NC 27932

Job 24020110	Truss F04	Truss Type Floor	Qty 6	Ply 1	DRB - 71 FaNC Job Reference (optional)	163855464
-----------------	--------------	---------------------	----------	----------	---	-----------

Carter Components (Sanford, NC), Sanford, NC - 27332,

Run: 8.63 S Nov 1 2023 Print: 8.630 S Nov 1 2023 MiTek Industries, Inc. Mon Feb 26 11:35:16
ID:9Yvx_OfPdfTnL0kOR0GKrcznBc9-RfC?PsB70Hq3NSgPqnL8w3uITXbGKWrCDoi7J4zJC7f

Page: 1

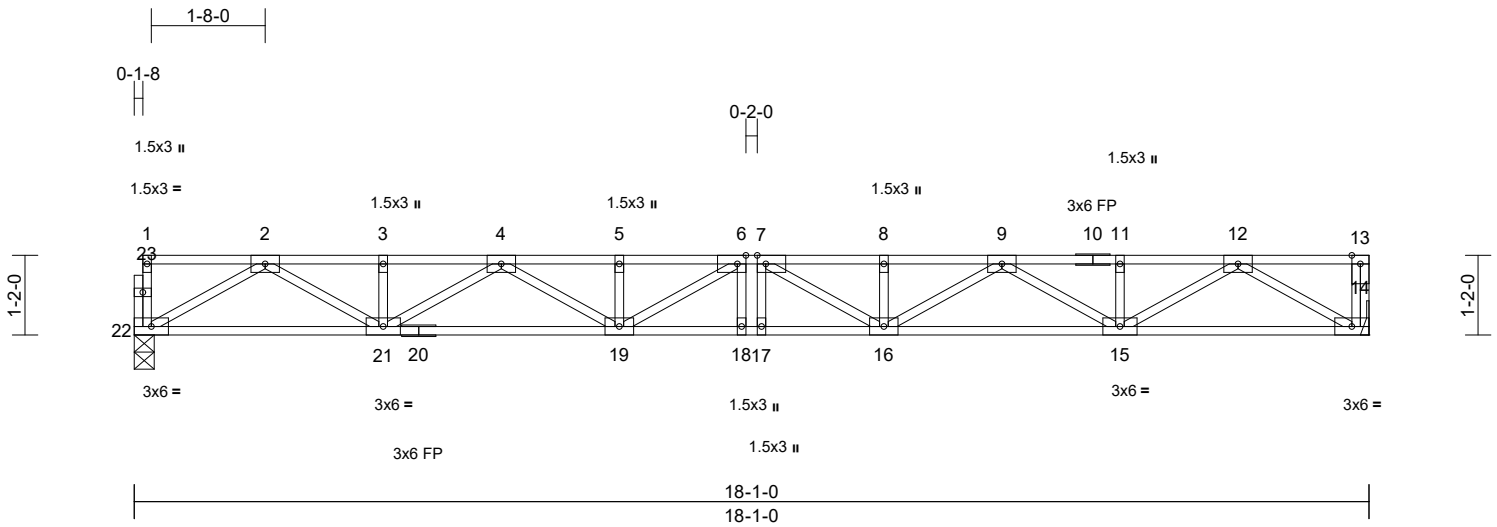

Scale = 1:33.7

Plate Offsets (X, Y): [6:0-1-8,Edge], [7:0-1-8,Edge]

Loading	(psf)	Spacing	1-4-0	CSI	DEFL	in	(loc)	l/defl	L/d	PLATES	GRIP	
TCLL	40.0	Plate Grip DOL	1.00	TC	0.24	Vert(LL)	-0.23	18	>930	480	MT20	244/190
TCDL	10.0	Lumber DOL	1.00	BC	0.77	Vert(CT)	-0.32	18	>676	360		
BCLL	0.0	Rep Stress Incr	YES	WB	0.43	Horz(CT)	0.06	14	n/a	n/a		
BCDL	5.0	Code	IRC2018/TPI2014	Matrix-MSH							Weight: 95 lb	FT = 20%F, 11%E

LUMBER

TOP CHORD 2x4 SP No.2(flat)
BOT CHORD 2x4 SP No.2(flat)
WEBS 2x4 SP No.3(flat)
OTHERS 2x4 SP No.3(flat)

- 5) Recommend 2x6 strongbacks, on edge, spaced at 10-00-00 oc and fastened to each truss with 3-10d (0.131" X 3") nails. Strongbacks to be attached to walls at their outer ends or restrained by other means.
- 6) CAUTION, Do not erect truss backwards.

BRACING

TOP CHORD Structural wood sheathing directly applied or 6-0-0 oc purlins, except end verticals.
BOT CHORD Rigid ceiling directly applied or 10-0-0 oc bracing.

LOAD CASE(S) Standard

REACTIONS

(size) 14= Mechanical, 22=0-3-8
Max Grav 14=654 (LC 1), 22=650 (LC 1)

FORCES

(lb) - Maximum Compression/Maximum Tension

TOP CHORD 1-22=-48/0, 13-14=-49/0, 1-2=-3/0,
2-3=-1787/0, 3-4=-1787/0, 4-5=-2674/0,
5-6=-2674/0, 6-7=-2798/0, 7-8=-2674/0,
8-9=-2674/0, 9-11=-1787/0, 11-12=-1787/0,
12-13=0/0
BOT CHORD 21-22=0/1020, 19-21=0/2326, 18-19=0/2798,
17-18=0/2798, 16-17=0/2798, 15-16=0/2326,
14-15=0/1022
WEBS 12-14=-1182/0, 2-22=-1177/0, 12-15=0/893,
2-21=0/895, 11-15=-110/0, 3-21=-112/0,
9-15=-630/0, 4-21=-629/0, 9-16=0/406,
4-19=0/406, 8-16=-130/0, 5-19=-130/0,
7-16=-309/114, 6-19=-309/114, 6-18=-76/85,
7-17=-76/85

NOTES

- 1) Unbalanced floor live loads have been considered for this design.
- 2) All plates are 3x5 MT20 unless otherwise indicated.
- 3) Refer to girder(s) for truss to truss connections.
- 4) This truss is designed in accordance with the 2018 International Residential Code sections R502.11.1 and R802.10.2 and referenced standard ANSI/TPI 1.

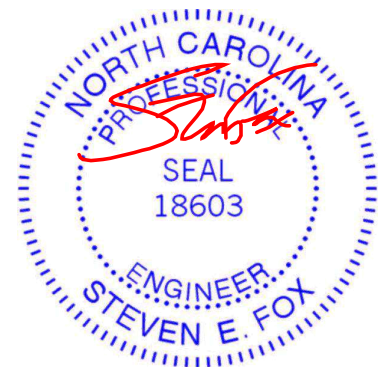

February 27, 2024

WARNING - Verify design parameters and READ NOTES ON THIS AND INCLUDED MITEK REFERENCE PAGE MII-7473 rev. 1/2/2023 BEFORE USE.

Design valid for use only with MiTek® connectors. This design is based only upon parameters shown, and is for an individual building component, not a truss system. Before use, the building designer must verify the applicability of design parameters and properly incorporate this design into the overall building design. Bracing indicated is to prevent buckling of individual truss web and/or chord members only. Additional temporary and permanent bracing is always required for stability and to prevent collapse with possible personal injury and property damage. For general guidance regarding the fabrication, storage, delivery, erection and bracing of trusses and truss systems, see **ANSI/TPI1 Quality Criteria and DSB-22** available from Truss Plate Institute (www.tpinst.org) and **BCSI Building Component Safety Information** available from the Structural Building Component Association (www.sbcacomponents.com)



818 Soundside Road
Edenton, NC 27932

Job 24020110	Truss F05	Truss Type Floor Girder	Qty 1	Ply 1	DRB - 71 FaNC Job Reference (optional)	163855465
-----------------	--------------	----------------------------	----------	----------	---	-----------

Carter Components (Sanford, NC), Sanford, NC - 27332,

Run: 8.63 S Nov 1 2023 Print: 8.630 S Nov 1 2023 MiTek Industries, Inc. Mon Feb 26 11:35:16
ID:t1_Yzn4sX6gPLl1q80rDynznBZ1-RfC?PsB70Hq3NSgPqnL8w3uTXbGKWrCDoi7J4zJC?F

Page: 1

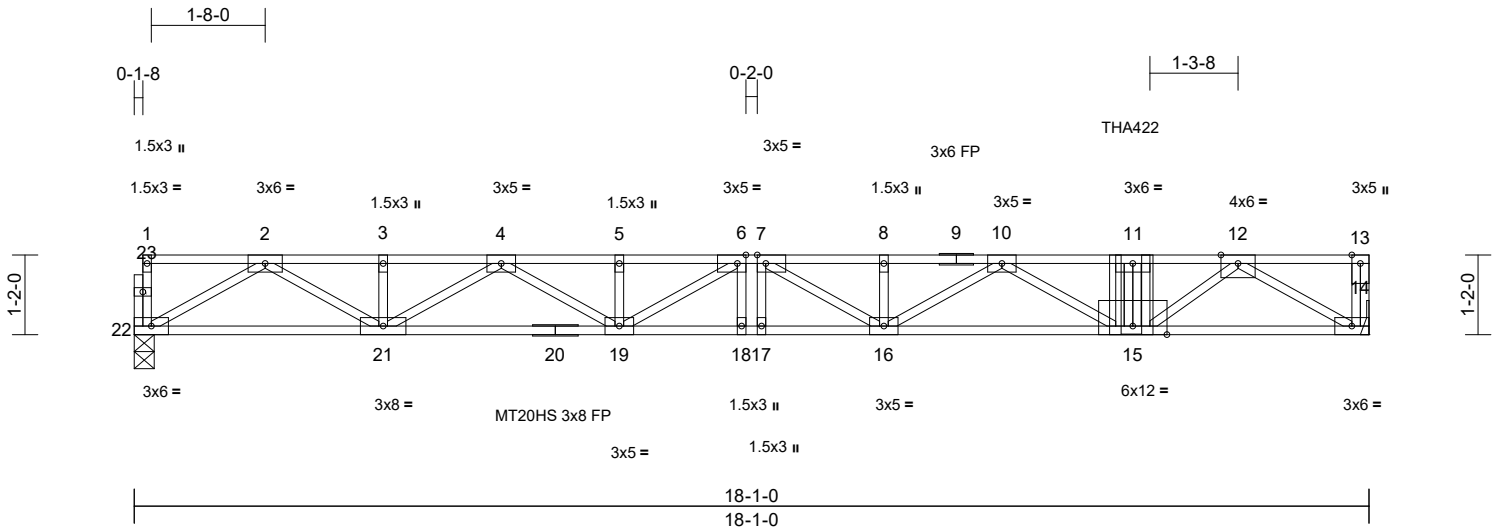

Scale = 1:33.7

Plate Offsets (X, Y): [6:0-1-8,Edge], [7:0-1-8,Edge]

Loading	(psf)	Spacing	1-4-0	CSI	DEFL	in	(loc)	l/defl	L/d	PLATES	GRIP	
TCLL	40.0	Plate Grip DOL	1.00	TC	0.44	Vert(LL)	-0.29	16-17	>745	480	MT20HS	187/143
TCDL	10.0	Lumber DOL	1.00	BC	0.88	Vert(CT)	-0.40	16-17	>540	360	MT20	244/190
BCLL	0.0	Rep Stress Incr	NO	WB	0.73	Horz(CT)	0.07	14	n/a	n/a		
BCDL	5.0	Code	IRC2018/TPI2014	Matrix-MSH							Weight: 99 lb	FT = 20%F, 11%E

LUMBER

TOP CHORD 2x4 SP No.2(flat)
 BOT CHORD 2x4 SP No.2(flat) *Except* 20-14:2x4 SP No.1(flat)
 WEBS 2x4 SP No.3(flat)
 OTHERS 2x4 SP No.3(flat)

BRACING

TOP CHORD Structural wood sheathing directly applied or 6-0-0 oc purlins, except end verticals.
 BOT CHORD Rigid ceiling directly applied or 10-0-0 oc bracing.

REACTIONS (size) 14= Mechanical, 22=0-3-8
 Max Grav 14=1047 (LC 1), 22=740 (LC 1)

FORCES (lb) - Maximum Compression/Maximum Tension

TOP CHORD 1-22=-48/0, 13-14=-51/0, 1-2=-3/0, 2-3=-2092/0, 3-4=-2092/0, 4-5=-3273/0, 5-6=-3273/0, 6-7=-3570/0, 7-8=-3613/0, 8-10=-3613/0, 10-11=-2964/0, 11-12=-2964/0, 12-13=0/0

BOT CHORD 21-22=0/1175, 19-21=0/2780, 18-19=0/3570, 17-18=0/3570, 16-17=0/3570, 15-16=0/3417, 14-15=0/1694

WEBS 12-14=-1959/0, 2-22=-1356/0, 2-21=0/1070, 11-15=-624/0, 3-21=-111/0, 10-15=-516/0, 4-21=-804/0, 10-16=0/229, 4-19=0/575, 8-16=-129/0, 5-19=-121/0, 7-16=-99/323, 6-19=-523/0, 6-18=-28/144, 7-17=-135/37, 12-15=0/1533

NOTES

- 1) Unbalanced floor live loads have been considered for this design.
- 2) All plates are MT20 plates unless otherwise indicated.
- 3) Refer to girder(s) for truss to truss connections.
- 4) This truss is designed in accordance with the 2018 International Residential Code sections R502.11.1 and R802.10.2 and referenced standard ANSI/TPI 1.

- 5) Recommend 2x6 strongbacks, on edge, spaced at 10-00-00 oc and fastened to each truss with 3-10d (0.131" X 3") nails. Strongbacks to be attached to walls at their outer ends or restrained by other means.
- 6) CAUTION, Do not erect truss backwards.
- 7) Use Simpson Strong-Tie THA422 (Single Chord Girder) or equivalent at 14-7-4 from the left end to connect truss (es) to front face of top chord.
- 8) Fill all nail holes where hanger is in contact with lumber.
- 9) In the LOAD CASE(S) section, loads applied to the face of the truss are noted as front (F) or back (B).

LOAD CASE(S) Standard

- 1) Dead + Floor Live (balanced): Lumber Increase=1.00, Plate Increase=1.00
 Uniform Loads (lb/ft)
 Vert: 14-22=-7, 1-13=-67
 Concentrated Loads (lb)
 Vert: 11=-484 (F)

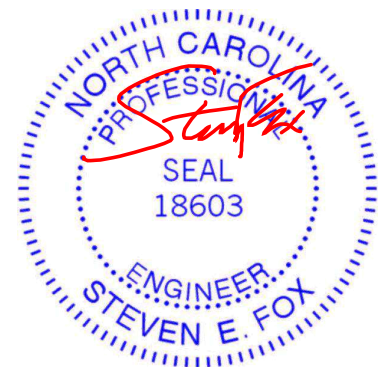

February 27, 2024

WARNING - Verify design parameters and READ NOTES ON THIS AND INCLUDED MITEK REFERENCE PAGE MII-7473 rev. 1/2/2023 BEFORE USE.

Design valid for use only with MiTek® connectors. This design is based only upon parameters shown, and is for an individual building component, not a truss system. Before use, the building designer must verify the applicability of design parameters and properly incorporate this design into the overall building design. Bracing indicated is to prevent buckling of individual truss web and/or chord members only. Additional temporary and permanent bracing is always required for stability and to prevent collapse with possible personal injury and property damage. For general guidance regarding the fabrication, storage, delivery, erection and bracing of trusses and truss systems, see **ANSI/TPI1 Quality Criteria and DSB-22** available from Truss Plate Institute (www.tpinst.org) and **BCSI Building Component Safety Information** available from the Structural Building Component Association (www.sbcacomponents.com)

ENGINEERING BY
TRENCO
 A MiTek Affiliate

818 Soundside Road
 Edenton, NC 27932

Job 24020110	Truss F06	Truss Type Floor	Qty 4	Ply 1	DRB - 71 FaNC Job Reference (optional)	163855466
-----------------	--------------	---------------------	----------	----------	---	-----------

Carter Components (Sanford, NC), Sanford, NC - 27332,

Run: 8.63 S Nov 1 2023 Print: 8.630 S Nov 1 2023 MiTek Industries, Inc. Mon Feb 26 11:35:16
ID:aO6VBduywp_xl5GEcDd0fqznBbr-RfC?PsB70Hq3NSgPqnL8w3uITXbGKWrCDoi7J4zJC?f

Page: 1

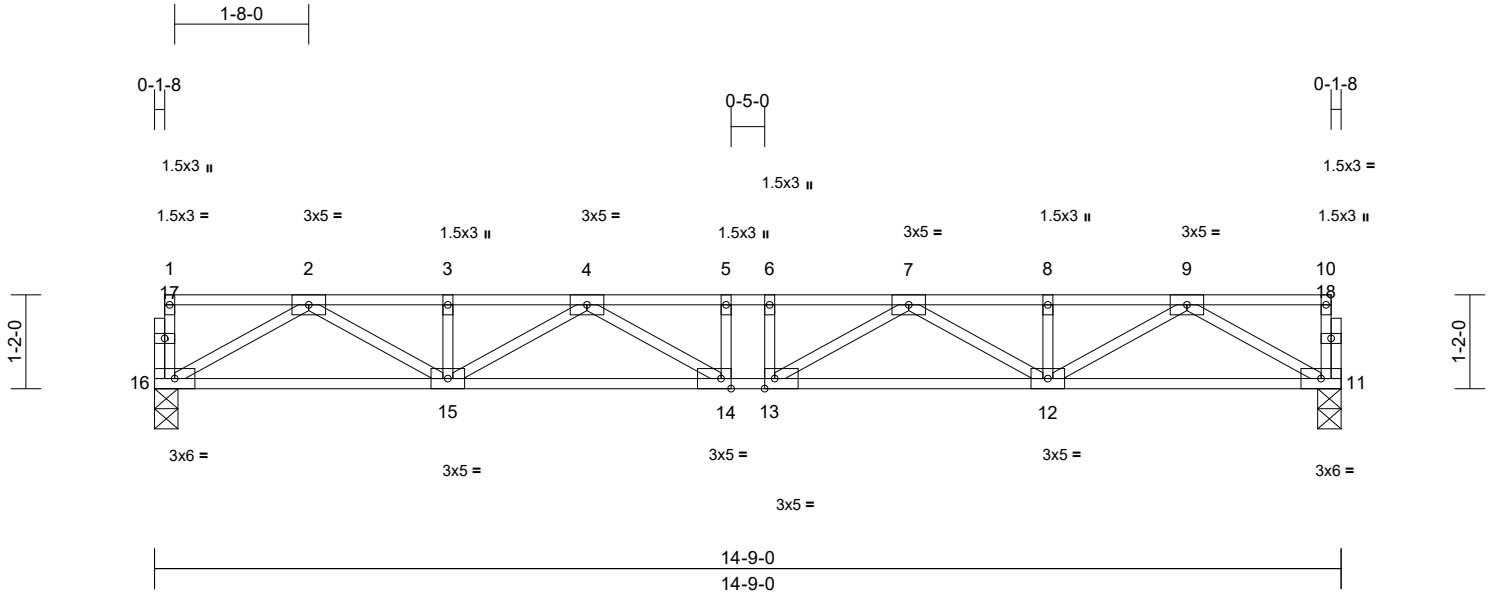

Scale = 1:28.6

Plate Offsets (X, Y): [13:0-1-8,Edge], [14:0-1-8,Edge]

Loading	(psf)	Spacing	1-4-0	CSI	DEFL	in	(loc)	l/defl	L/d	PLATES	GRIP	
TCLL	40.0	Plate Grip DOL	1.00	TC	0.17	Vert(LL)	-0.11	13-14	>999	480	MT20	244/190
TCDL	10.0	Lumber DOL	1.00	BC	0.50	Vert(CT)	-0.14	14	>999	360		
BCLL	0.0	Rep Stress Incr	YES	WB	0.31	Horz(CT)	0.03	11	n/a	n/a		
BCDL	5.0	Code	IRC2018/TPI2014	Matrix-MSH							Weight: 77 lb	FT = 20%F, 11%E

LUMBER

TOP CHORD 2x4 SP No.2(flat)
 BOT CHORD 2x4 SP No.2(flat)
 WEBS 2x4 SP No.3(flat)
 OTHERS 2x4 SP No.3(flat)

BRACING

TOP CHORD Structural wood sheathing directly applied or 6-0-0 oc purlins, except end verticals.
 BOT CHORD Rigid ceiling directly applied or 10-0-0 oc bracing.

REACTIONS (size) 11=0-3-8, 16=0-3-8
 Max Grav 11=527 (LC 1), 16=527 (LC 1)

FORCES (lb) - Maximum Compression/Maximum Tension
 TOP CHORD 1-16=-47/0, 10-11=-47/0, 1-2=-3/0,
 2-3=-1375/0, 3-4=-1375/0, 4-5=-1852/0,
 5-6=-1852/0, 6-7=-1852/0, 7-8=-1375/0,
 8-9=-1375/0, 9-10=-3/0
 BOT CHORD 15-16=0/811, 14-15=0/1715, 13-14=0/1852,
 12-13=0/1715, 11-12=0/811
 WEBS 9-11=-935/0, 2-16=-935/0, 9-12=0/659,
 2-15=0/659, 8-12=-109/0, 3-15=-109/0,
 7-12=-396/0, 4-15=-396/0, 7-13=-44/284,
 4-14=-44/284, 5-14=-91/0, 6-13=-91/0

NOTES

- 1) Unbalanced floor live loads have been considered for this design.
- 2) All plates are 1.5x3 MT20 unless otherwise indicated.
- 3) This truss is designed in accordance with the 2018 International Residential Code sections R502.11.1 and R802.10.2 and referenced standard ANSI/TPI 1.
- 4) Recommend 2x6 strongbacks, on edge, spaced at 10-00-00 oc and fastened to each truss with 3-10d (0.131" X 3") nails. Strongbacks to be attached to walls at their outer ends or restrained by other means.

LOAD CASE(S) Standard



February 27, 2024

WARNING - Verify design parameters and READ NOTES ON THIS AND INCLUDED MITEK REFERENCE PAGE MII-7473 rev. 1/2/2023 BEFORE USE.
 Design valid for use only with MiTek® connectors. This design is based only upon parameters shown, and is for an individual building component, not a truss system. Before use, the building designer must verify the applicability of design parameters and properly incorporate this design into the overall building design. Bracing indicated is to prevent buckling of individual truss web and/or chord members only. Additional temporary and permanent bracing is always required for stability and to prevent collapse with possible personal injury and property damage. For general guidance regarding the fabrication, storage, delivery, erection and bracing of trusses and truss systems, see **ANSI/TPI1 Quality Criteria and DSB-22** available from Truss Plate Institute (www.tpinst.org) and **BCSI Building Component Safety Information** available from the Structural Building Component Association (www.sbcacomponents.com)



818 Soundside Road
 Edenton, NC 27932

Job 24020110	Truss F07	Truss Type Floor	Qty 2	Ply 1	DRB - 71 FaNC Job Reference (optional)	163855467
-----------------	--------------	---------------------	----------	----------	---	-----------

Carter Components (Sanford, NC), Sanford, NC - 27332,

Run: 8.63 S Nov 1 2023 Print: 8.630 S Nov 1 2023 MiTek Industries, Inc. Mon Feb 26 11:35:16
ID:SRIRbP87zFeymJNGK7Vx?FznBbW-RfC?PsB70Hq3NSgPqnl8w3uITXbGkWrCDoi7J4zJC?f

Page: 1

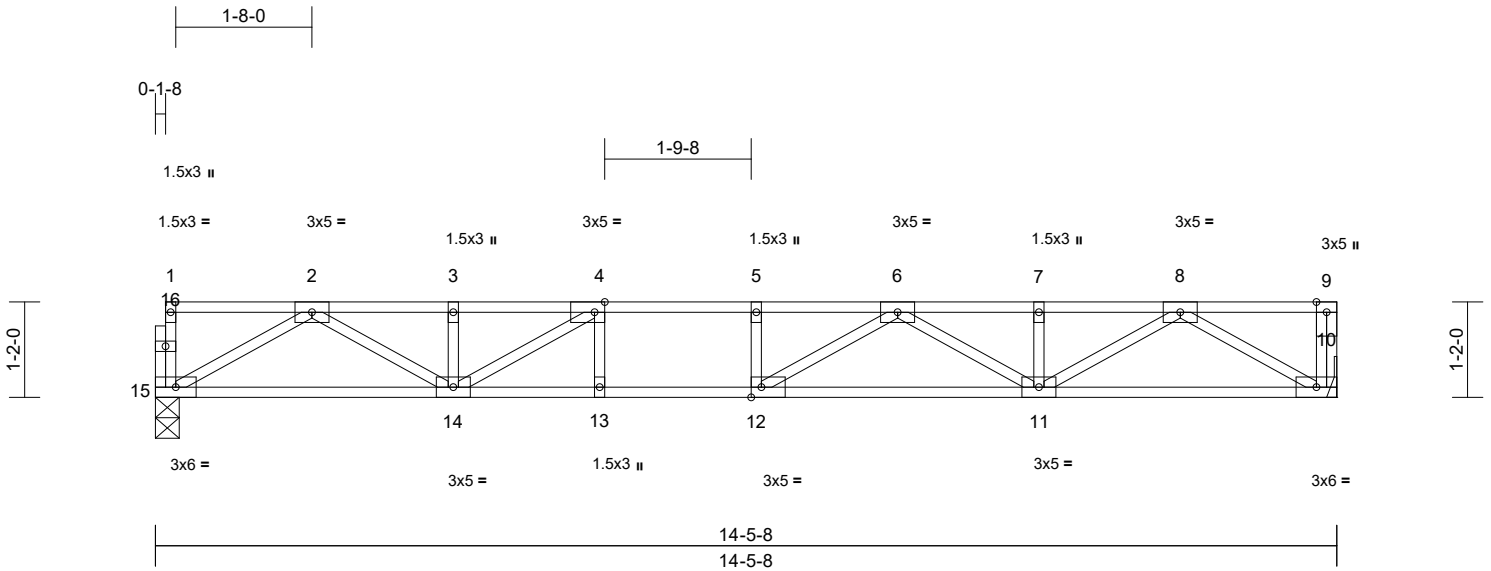

Scale = 1:28.2

Plate Offsets (X, Y): [4:0-1-8,Edge], [12:0-1-8,Edge]

Loading	(psf)	Spacing	1-4-0	CSI	DEFL	in	(loc)	l/defl	L/d	PLATES	GRIP	
TCLL	40.0	Plate Grip DOL	1.00	TC	0.46	Vert(LL)	-0.14	11-12	>999	480	MT20	244/190
TCDL	10.0	Lumber DOL	1.00	BC	0.69	Vert(CT)	-0.19	11-12	>889	360		
BCLL	0.0	Rep Stress Incr	YES	WB	0.30	Horz(CT)	0.03	10	n/a	n/a		
BCDL	5.0	Code	IRC2018/TPI2014	Matrix-MSH							Weight: 73 lb	FT = 20%F, 11%E

- LUMBER**
- TOP CHORD 2x4 SP No.2(flat)
 - BOT CHORD 2x4 SP No.2(flat)
 - WEBS 2x4 SP No.3(flat)
 - OTHERS 2x4 SP No.3(flat)
- BRACING**
- TOP CHORD Structural wood sheathing directly applied or 6-0-0 oc purlins, except end verticals.
 - BOT CHORD Rigid ceiling directly applied or 10-0-0 oc bracing.
- REACTIONS** (size) 10= Mechanical, 15=0-3-8
Max Grav 10=521 (LC 1), 15=517 (LC 1)
- FORCES** (lb) - Maximum Compression/Maximum Tension
- TOP CHORD 1-15=-47/0, 9-10=-49/0, 1-2=-3/0, 2-3=-1326/0, 3-4=-1326/0, 4-5=-1734/0, 5-6=-1734/0, 6-7=-1343/0, 7-8=-1343/0, 8-9=0/0
 - BOT CHORD 14-15=0/792, 13-14=0/1734, 12-13=0/1734, 11-12=0/1660, 10-11=0/797
 - WEBS 8-10=-922/0, 2-15=-913/0, 8-11=0/637, 2-14=0/624, 7-11=-102/0, 3-14=-125/42, 6-11=-370/0, 4-14=-567/0, 6-12=-71/281, 4-13=-19/94, 5-12=-107/0

- NOTES**
- Unbalanced floor live loads have been considered for this design.
 - All plates are 3x5 MT20 unless otherwise indicated.
 - Refer to girder(s) for truss to truss connections.
 - This truss is designed in accordance with the 2018 International Residential Code sections R502.11.1 and R802.10.2 and referenced standard ANSI/TPI 1.
 - Recommend 2x6 strongbacks, on edge, spaced at 10-00-00 oc and fastened to each truss with 3-10d (0.131" X 3") nails. Strongbacks to be attached to walls at their outer ends or restrained by other means.
 - CAUTION, Do not erect truss backwards.
- LOAD CASE(S)** Standard

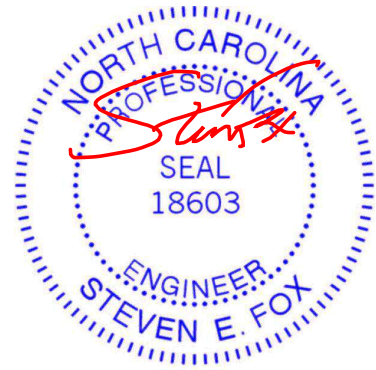

February 27, 2024

WARNING - Verify design parameters and READ NOTES ON THIS AND INCLUDED MITEK REFERENCE PAGE MII-7473 rev. 1/2/2023 BEFORE USE.

Design valid for use only with MiTek® connectors. This design is based only upon parameters shown, and is for an individual building component, not a truss system. Before use, the building designer must verify the applicability of design parameters and properly incorporate this design into the overall building design. Bracing indicated is to prevent buckling of individual truss web and/or chord members only. Additional temporary and permanent bracing is always required for stability and to prevent collapse with possible personal injury and property damage. For general guidance regarding the fabrication, storage, delivery, erection and bracing of trusses and truss systems, see **ANSI/TPI1 Quality Criteria and DSB-22** available from Truss Plate Institute (www.tpinst.org) and **BCSI Building Component Safety Information** available from the Structural Building Component Association (www.sbcacomponents.com)



818 Soundside Road
Edenton, NC 27932

Job 24020110	Truss F08	Truss Type Floor	Qty 6	Ply 1	DRB - 71 FaNC Job Reference (optional)	163855468
-----------------	--------------	---------------------	----------	----------	---	-----------

Carter Components (Sanford, NC), Sanford, NC - 27332,

Run: 8.63 S Nov 1 2023 Print: 8.630 S Nov 1 2023 MiTek Industries, Inc. Mon Feb 26 11:35:16
ID:Ad0eFeT3cY17VTxSQLUGbyznBb5-RfC?PsB70Hq3NSgPqnL8w3uITXbGKWrCDoi7J4zJC?f

Page: 1

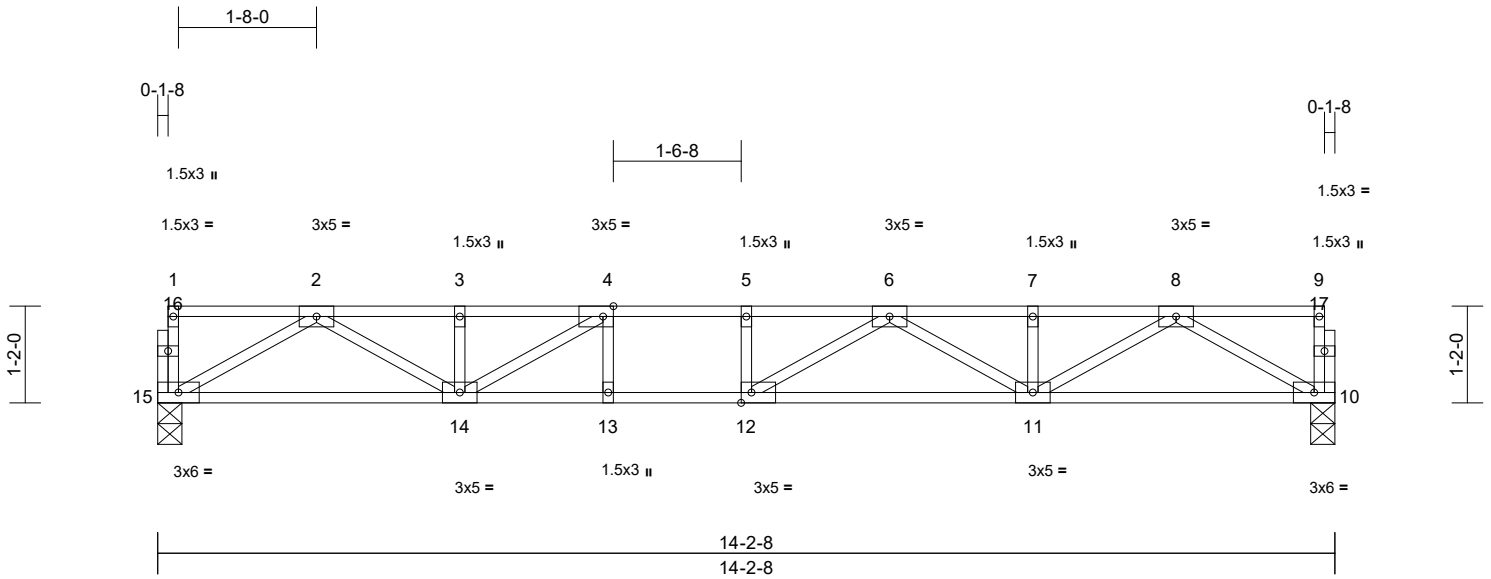

Scale = 1:27.8

Plate Offsets (X, Y): [4:0-1-8,Edge], [12:0-1-8,Edge]

Loading	(psf)	Spacing	1-4-0	CSI	DEFL	in	(loc)	l/defl	L/d	PLATES	GRIP	
TCLL	40.0	Plate Grip DOL	1.00	TC	0.41	Vert(LL)	-0.12	11-12	>999	480	MT20	244/190
TCDL	10.0	Lumber DOL	1.00	BC	0.63	Vert(CT)	-0.17	11-12	>999	360		
BCLL	0.0	Rep Stress Incr	YES	WB	0.30	Horz(CT)	0.03	10	n/a	n/a		
BCDL	5.0	Code	IRC2018/TPI2014	Matrix-MSH							Weight: 72 lb	FT = 20%F, 11%E

LUMBER

TOP CHORD 2x4 SP No.2(flat)
BOT CHORD 2x4 SP No.2(flat)
WEBS 2x4 SP No.3(flat)
OTHERS 2x4 SP No.3(flat)

BRACING

TOP CHORD Structural wood sheathing directly applied or 6-0-0 oc purlins, except end verticals.
BOT CHORD Rigid ceiling directly applied or 10-0-0 oc bracing.

REACTIONS (size) 10=0-3-8, 15=0-3-8
Max Grav 10=508 (LC 1), 15=508 (LC 1)

FORCES (lb) - Maximum Compression/Maximum Tension

TOP CHORD 1-15=-48/0, 9-10=-47/0, 1-2=-3/0,
2-3=-1298/0, 3-4=-1298/0, 4-5=-1677/0,
5-6=-1677/0, 6-7=-1312/0, 7-8=-1312/0,
8-9=-3/0

BOT CHORD 14-15=0/776, 13-14=0/1677, 12-13=0/1677,
11-12=0/1615, 10-11=0/780

WEBS 8-10=-899/0, 2-15=-895/0, 8-11=0/620,
2-14=0/609, 7-11=-103/0, 3-14=-127/33,
6-11=-354/0, 4-14=-528/0, 6-12=-81/259,
4-13=-21/89, 5-12=-96/0

NOTES

- Unbalanced floor live loads have been considered for this design.
- All plates are 1.5x3 MT20 unless otherwise indicated.
- This truss is designed in accordance with the 2018 International Residential Code sections R502.11.1 and R802.10.2 and referenced standard ANSI/TPI 1.
- Recommend 2x6 strongbacks, on edge, spaced at 10-00-00 oc and fastened to each truss with 3-10d (0.131" X 3") nails. Strongbacks to be attached to walls at their outer ends or restrained by other means.

LOAD CASE(S) Standard

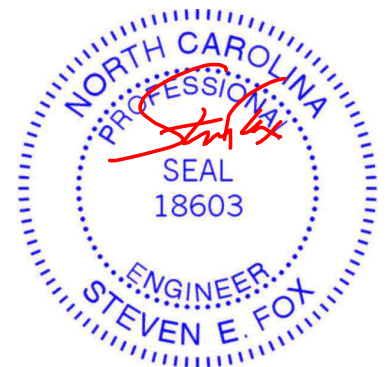

February 27, 2024

WARNING - Verify design parameters and READ NOTES ON THIS AND INCLUDED MITEK REFERENCE PAGE MII-7473 rev. 1/2/2023 BEFORE USE.

Design valid for use only with MiTek® connectors. This design is based only upon parameters shown, and is for an individual building component, not a truss system. Before use, the building designer must verify the applicability of design parameters and properly incorporate this design into the overall building design. Bracing indicated is to prevent buckling of individual truss web and/or chord members only. Additional temporary and permanent bracing is always required for stability and to prevent collapse with possible personal injury and property damage. For general guidance regarding the fabrication, storage, delivery, erection and bracing of trusses and truss systems, see **ANSI/TPI1 Quality Criteria and DSB-22** available from Truss Plate Institute (www.tpinst.org) and **BCSI Building Component Safety Information** available from the Structural Building Component Association (www.sbcacomponents.com)

ENGINEERING BY
TRENCO
A MiTek Affiliate

818 Soundside Road
Edenton, NC 27932

Job 24020110	Truss F09	Truss Type Floor	Qty 1	Ply 1	DRB - 71 FaNC Job Reference (optional)	163855469
-----------------	--------------	---------------------	----------	----------	---	-----------

Carter Components (Sanford, NC), Sanford, NC - 27332,

Run: 8.63 S Nov 1 2023 Print: 8.630 S Nov 1 2023 MiTek Industries, Inc. Mon Feb 26 11:35:17
ID:WbpXJLXCR5gQcEpQCR4RI?znBb0-RfC?PsB70Hq3NSgPqnL8w3uTXbGKWrCD0i7J4zJC?f

Page: 1

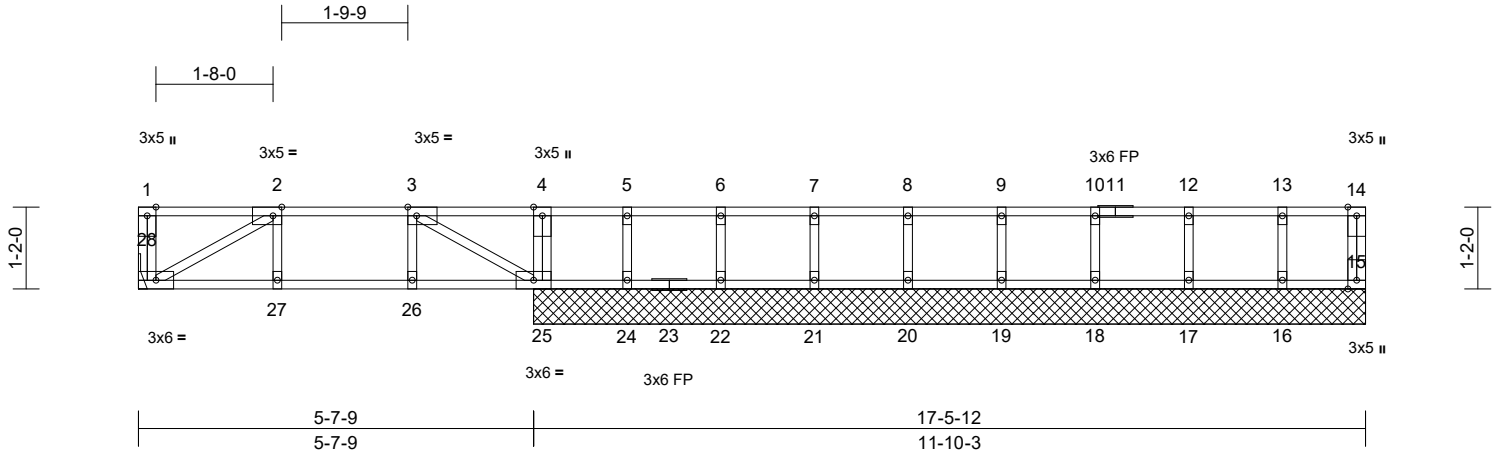

Scale = 1:32.8

Plate Offsets (X, Y): [2:0-1-8,Edge], [3:0-1-8,Edge]

Loading	(psf)	Spacing	1-4-0	CSI	DEFL	in	(loc)	l/defl	L/d	PLATES	GRIP	
TCLL	40.0	Plate Grip DOL	1.00	TC	0.13	Vert(LL)	-0.01	27-28	>999	480	MT20	244/190
TCDL	10.0	Lumber DOL	1.00	BC	0.14	Vert(CT)	-0.01	27-28	>999	360		
BCLL	0.0	Rep Stress Incr	YES	WB	0.07	Horz(CT)	0.00	15	n/a	n/a		
BCDL	5.0	Code	IRC2018/TPI2014	Matrix-MSH							Weight: 79 lb	FT = 20%F, 11%E

- LUMBER**
- TOP CHORD 2x4 SP No.2(flat)
 - BOT CHORD 2x4 SP No.2(flat)
 - WEBS 2x4 SP No.3(flat)
 - OTHERS 2x4 SP No.3(flat)

- BRACING**
- TOP CHORD Structural wood sheathing directly applied or 6-0-0 oc purlins, except end verticals.
 - BOT CHORD Rigid ceiling directly applied or 10-0-0 oc bracing.

- REACTIONS** (size)
- 15=11-10-3, 16=11-10-3, 17=11-10-3, 18=11-10-3, 19=11-10-3, 20=11-10-3, 21=11-10-3, 22=11-10-3, 24=11-10-3, 25=11-10-3, 28= Mechanical
 - Max Grav 15=29 (LC 3), 16=97 (LC 4), 17=98 (LC 3), 18=98 (LC 4), 19=98 (LC 3), 20=98 (LC 4), 21=99 (LC 3), 22=105 (LC 4), 24=111 (LC 3), 25=262 (LC 1), 28=203 (LC 1)

- FORCES** (lb) - Maximum Compression/Maximum Tension
- TOP CHORD 1-28=-54/0, 14-15=-26/0, 1-2=0/0, 2-3=-259/0, 3-4=0/0, 4-5=0/0, 5-6=0/0, 6-7=0/0, 7-8=0/0, 8-9=0/0, 9-10=0/0, 10-12=0/0, 12-13=0/0, 13-14=0/0
 - BOT CHORD 27-28=0/259, 26-27=0/259, 25-26=0/259, 24-25=0/0, 22-24=0/0, 21-22=0/0, 20-21=0/0, 19-20=0/0, 18-19=0/0, 17-18=0/0, 16-17=0/0, 15-16=0/0
 - WEBS 4-25=-118/0, 3-25=-297/0, 2-28=-297/0, 2-27=-4/26, 3-26=-5/33, 5-24=-97/0, 6-22=-94/0, 7-21=-89/0, 8-20=-89/0, 9-19=-89/0, 10-18=-89/0, 12-17=-89/0, 13-16=-88/0

NOTES

- Unbalanced floor live loads have been considered for this design.
- All plates are 1.5x3 MT20 unless otherwise indicated.
- Truss to be fully sheathed from one face or securely braced against lateral movement (i.e. diagonal web).
- Gable studs spaced at 1-4-0 oc.
- Refer to girder(s) for truss to truss connections.
- This truss is designed in accordance with the 2018 International Residential Code sections R502.11.1 and R802.10.2 and referenced standard ANSI/TPI 1.
- Recommend 2x6 strongbacks, on edge, spaced at 10-00-00 oc and fastened to each truss with 3-10d (0.131" X 3") nails. Strongbacks to be attached to walls at their outer ends or restrained by other means.
- CAUTION, Do not erect truss backwards.

LOAD CASE(S) Standard

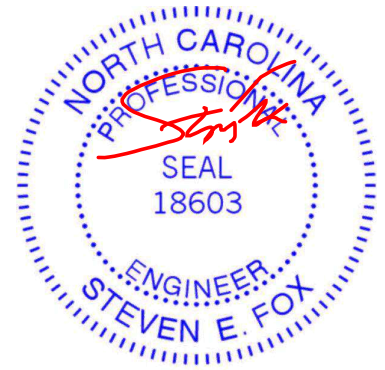

February 27, 2024

WARNING - Verify design parameters and READ NOTES ON THIS AND INCLUDED MITEK REFERENCE PAGE MII-7473 rev. 1/2/2023 BEFORE USE.

Design valid for use only with MiTek® connectors. This design is based only upon parameters shown, and is for an individual building component, not a truss system. Before use, the building designer must verify the applicability of design parameters and properly incorporate this design into the overall building design. Bracing indicated is to prevent buckling of individual truss web and/or chord members only. Additional temporary and permanent bracing is always required for stability and to prevent collapse with possible personal injury and property damage. For general guidance regarding the fabrication, storage, delivery, erection and bracing of trusses and truss systems, see **ANSI/TPI1 Quality Criteria and DSB-22** available from Truss Plate Institute (www.tpinst.org) and **BCSI Building Component Safety Information** available from the Structural Building Component Association (www.sbcacomponents.com)



818 Soundside Road
Edenton, NC 27932

Job 24020110	Truss F10	Truss Type Floor Girder	Qty 1	Ply 1	DRB - 71 FaNC Job Reference (optional)	I63855470
-----------------	--------------	----------------------------	----------	----------	---	-----------

Carter Components (Sanford, NC), Sanford, NC - 27332,

Run: 8.63 S Nov 1 2023 Print: 8.630 S Nov 1 2023 MiTek Industries, Inc. Mon Feb 26 11:35:17

Page: 1

ID:PR9IQzPMUDKCEIKGzMKDBznBZu-RfC?PsB70Hq3NSgPqnL8w3uITXbGKWrCdoi7J4zJC?f

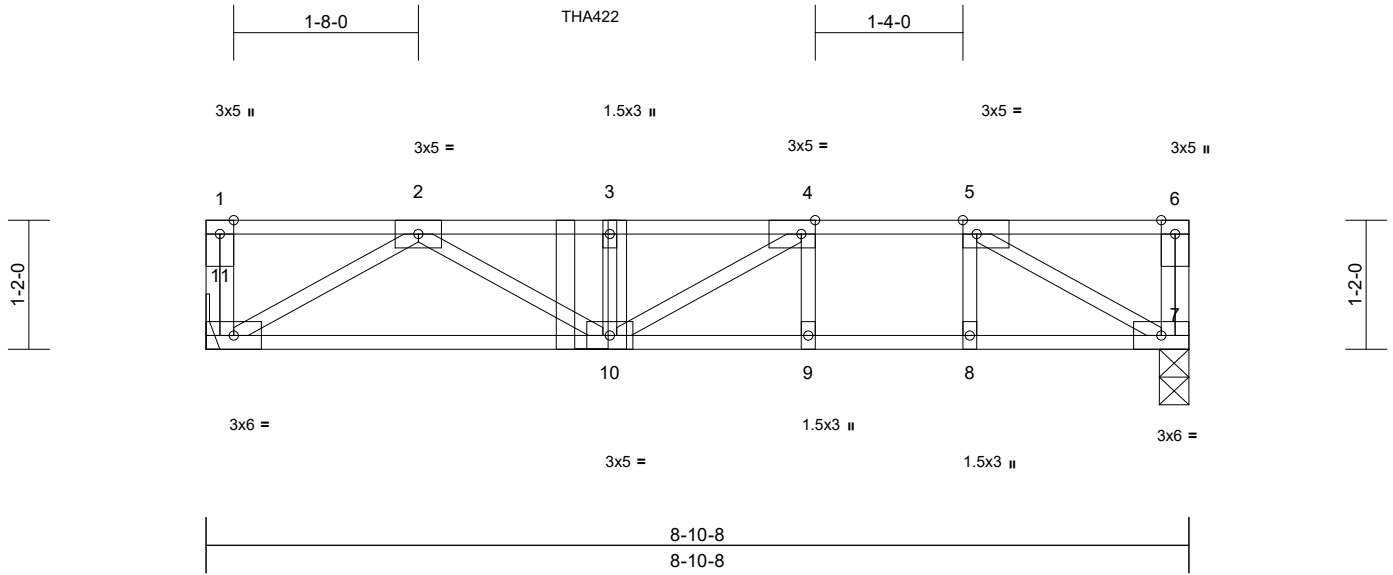

Scale = 1:20.8

Plate Offsets (X, Y): [4:0-1-8,Edge], [5:0-1-8,Edge]

Loading	(psf)	Spacing	1-4-0	CSI	DEFL	in	(loc)	l/defl	L/d	PLATES	GRIP	
TCLL	40.0	Plate Grip DOL	1.00	TC	0.52	Vert(LL)	-0.08	9-10	>999	480	MT20	244/190
TCDL	10.0	Lumber DOL	1.00	BC	0.69	Vert(CT)	-0.10	9-10	>999	360		
BCLL	0.0	Rep Stress Incr	NO	WB	0.19	Horz(CT)	0.01	7	n/a	n/a		
BCDL	5.0	Code	IRC2018/TPI2014	Matrix-MSH							Weight: 47 lb	FT = 20%F, 11%E

LUMBER

TOP CHORD 2x4 SP No.2(flat)
BOT CHORD 2x4 SP No.2(flat)
WEBS 2x4 SP No.3(flat)

BRACING

TOP CHORD Structural wood sheathing directly applied or 6-0-0 oc purlins, except end verticals.
BOT CHORD Rigid ceiling directly applied or 10-0-0 oc bracing.

REACTIONS (size) 7=0-3-3, 11= Mechanical
Max Grav 7=354 (LC 1), 11=378 (LC 3)

FORCES (lb) - Maximum Compression/Maximum Tension

TOP CHORD 1-11=-51/0, 6-7=-36/27, 1-2=0/0, 2-3=-886/0, 3-4=-886/0, 4-5=-633/0, 5-6=0/0
BOT CHORD 10-11=0/550, 9-10=0/633, 8-9=0/633, 7-8=0/633
WEBS 5-7=-726/0, 2-11=-636/0, 2-10=0/393, 3-10=-299/0, 4-10=0/334, 4-9=-136/0, 5-8=0/144

NOTES

- 1) Unbalanced floor live loads have been considered for this design.
- 2) Refer to girder(s) for truss to truss connections.
- 3) This truss is designed in accordance with the 2018 International Residential Code sections R502.11.1 and R802.10.2 and referenced standard ANSI/TPI 1.
- 4) Recommend 2x6 strongbacks, on edge, spaced at 10-00-00 oc and fastened to each truss with 3-10d (0.131" X 3") nails. Strongbacks to be attached to walls at their outer ends or restrained by other means.
- 5) Use Simpson Strong-Tie THA422 (Single Chord Girder) or equivalent at 3-5-12 from the left end to connect truss(es) to front face of top chord.
- 6) Fill all nail holes where hanger is in contact with lumber.
- 7) In the LOAD CASE(S) section, loads applied to the face of the truss are noted as front (F) or back (B).

LOAD CASE(S) Standard

- 1) Dead + Floor Live (balanced): Lumber Increase=1.00, Plate Increase=1.00
Uniform Loads (lb/ft)
Vert: 7-11=-7, 1-6=-67
Concentrated Loads (lb)
Vert: 3=-91 (F)

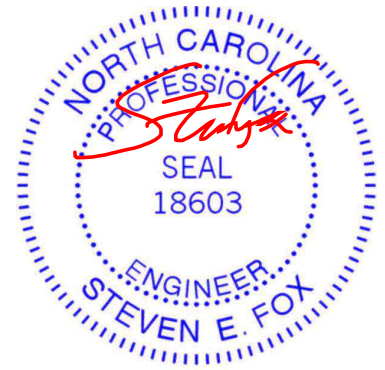

February 27, 2024

WARNING - Verify design parameters and READ NOTES ON THIS AND INCLUDED MITEK REFERENCE PAGE MII-7473 rev. 1/2/2023 BEFORE USE.

Design valid for use only with MiTek® connectors. This design is based only upon parameters shown, and is for an individual building component, not a truss system. Before use, the building designer must verify the applicability of design parameters and properly incorporate this design into the overall building design. Bracing indicated is to prevent buckling of individual truss web and/or chord members only. Additional temporary and permanent bracing is always required for stability and to prevent collapse with possible personal injury and property damage. For general guidance regarding the fabrication, storage, delivery, erection and bracing of trusses and truss systems, see **ANSI/TPI1 Quality Criteria and DSB-22** available from Truss Plate Institute (www.tpinst.org) and **BCSI Building Component Safety Information** available from the Structural Building Component Association (www.sbcacomponents.com)

ENGINEERING BY
TRENCO
A MiTek Affiliate

818 Soundside Road
Edenton, NC 27932

Job 24020110	Truss F11	Truss Type Floor Girder	Qty 1	Ply 1	DRB - 71 FaNC Job Reference (optional)	I63855471
-----------------	--------------	----------------------------	----------	----------	---	-----------

Carter Components (Sanford, NC), Sanford, NC - 27332,

Run: 8.63 S Nov 1 2023 Print: 8.630 S Nov 1 2023 MiTek Industries, Inc. Mon Feb 26 11:35:17
ID:PAeKr9CiU_bcihX_xuZL1bznBa9-RfC?PsB70Hq3NSgPqnL8w3uITXbGkWRCDoi7J4zJC?f

Page: 1

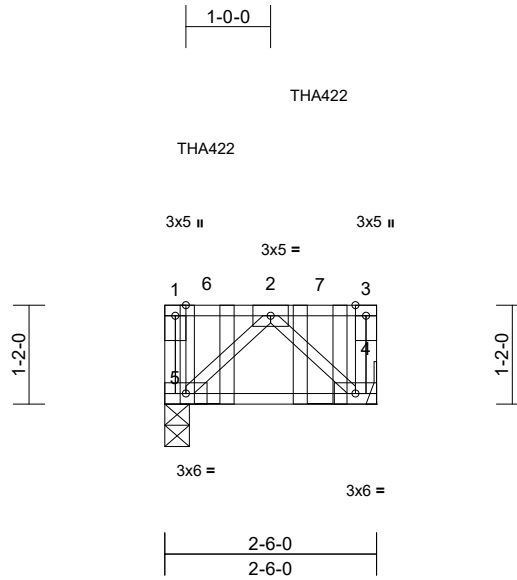

Scale = 1:27.2

Loading	(psf)	Spacing	1-4-0	CSI	DEFL	in	(loc)	l/defl	L/d	PLATES	GRIP	
TCLL	40.0	Plate Grip DOL	1.00	TC	0.65	Vert(LL)	n/a	-	n/a	999	MT20	244/190
TCDL	10.0	Lumber DOL	1.00	BC	0.13	Vert(CT)	0.00	4-5	>999	360		
BCLL	0.0	Rep Stress Incr	NO	WB	0.11	Horz(CT)	0.00	4	n/a	n/a		
BCDL	5.0	Code	IRC2018/TPI2014	Matrix-MP							Weight: 17 lb	FT = 20%F, 11%E

LUMBER

TOP CHORD 2x4 SP No.2(flat)
BOT CHORD 2x4 SP No.2(flat)
WEBS 2x4 SP No.3(flat)

BRACING

TOP CHORD Structural wood sheathing directly applied or 2-6-0 oc purlins, except end verticals.
BOT CHORD Rigid ceiling directly applied or 10-0-0 oc bracing.

REACTIONS (size) 4= Mechanical, 5=0-3-8
Max Grav 4=529 (LC 1), 5=603 (LC 1)

FORCES (lb) - Maximum Compression/Maximum Tension

TOP CHORD 1-5=-276/0, 3-4=-201/0, 1-2=0/0, 2-3=0/0
BOT CHORD 4-5=0/346
WEBS 2-5=-471/0, 2-4=-471/0

NOTES

- 1) Refer to girder(s) for truss to truss connections.
- 2) This truss is designed in accordance with the 2018 International Residential Code sections R502.11.1 and R802.10.2 and referenced standard ANSI/TPI 1.
- 3) Recommend 2x6 strongbacks, on edge, spaced at 10-00-00 oc and fastened to each truss with 3-10d (0.131" X 3") nails. Strongbacks to be attached to walls at their outer ends or restrained by other means.
- 4) Use Simpson Strong-Tie THA422 (Single Chord Girder) or equivalent spaced at 1-4-0 oc max. starting at 0-6-0 from the left end to 1-10-0 to connect truss(es) to back face of top chord.
- 5) Fill all nail holes where hanger is in contact with lumber.
- 6) In the LOAD CASE(S) section, loads applied to the face of the truss are noted as front (F) or back (B).

LOAD CASE(S) Standard

- 1) Dead + Floor Live (balanced): Lumber Increase=1.00, Plate Increase=1.00
Uniform Loads (lb/ft)
Vert: 4-5=-7, 1-3=-67
Concentrated Loads (lb)
Vert: 6=-486 (B), 7=-481 (B)



February 27, 2024

WARNING - Verify design parameters and READ NOTES ON THIS AND INCLUDED MITEK REFERENCE PAGE MII-7473 rev. 1/2/2023 BEFORE USE.

Design valid for use only with MiTek® connectors. This design is based only upon parameters shown, and is for an individual building component, not a truss system. Before use, the building designer must verify the applicability of design parameters and properly incorporate this design into the overall building design. Bracing indicated is to prevent buckling of individual truss web and/or chord members only. Additional temporary and permanent bracing is always required for stability and to prevent collapse with possible personal injury and property damage. For general guidance regarding the fabrication, storage, delivery, erection and bracing of trusses and truss systems, see **ANSI/TPI1 Quality Criteria and DSB-22** available from Truss Plate Institute (www.tpinst.org) and **BCSI Building Component Safety Information** available from the Structural Building Component Association (www.sbcacomponents.com)

ENGINEERING BY
TRENCO
A MiTek Affiliate

818 Soundside Road
Edenton, NC 27932

Job 24020110	Truss F12	Truss Type Floor Girder	Qty 1	Ply 1	DRB - 71 FaNC Job Reference (optional)	163855472
-----------------	--------------	----------------------------	----------	----------	---	-----------

Carter Components (Sanford, NC), Sanford, NC - 27332,

Run: 8.63 S Nov 1 2023 Print: 8.630 S Nov 1 2023 MiTek Industries, Inc. Mon Feb 26 11:35:17
ID:bloU9wKcuN_3WNs64IFwzwnBa_-RFC?PsB70Hq3NSgPqnL8w3uITXbGKWrCDoi7J4zJC?f

Page: 1

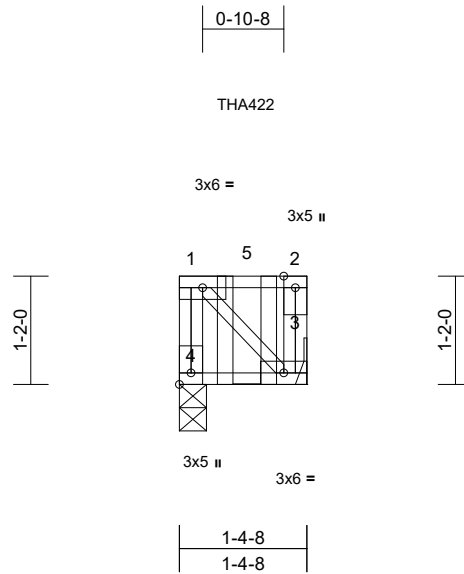

Scale = 1:24.8

Plate Offsets (X, Y): [4:Edge,0-1-8]

Loading	(psf)	Spacing	1-4-0	CSI	DEFL	in	(loc)	l/defl	L/d	PLATES	GRIP	
TCLL	40.0	Plate Grip DOL	1.00	TC	0.37	Vert(LL)	n/a	-	n/a	999	MT20	244/190
TCDL	10.0	Lumber DOL	1.00	BC	0.01	Vert(CT)	0.00	3-4	>999	360		
BCLL	0.0	Rep Stress Incr	NO	WB	0.00	Horz(CT)	0.00	3	n/a	n/a		
BCDL	5.0	Code	IRC2018/TPI2014	Matrix-MP							Weight: 11 lb	FT = 20%F, 11%E

LUMBER

TOP CHORD 2x4 SP No.2(flat)
BOT CHORD 2x4 SP No.2(flat)
WEBS 2x4 SP No.3(flat)

BRACING

TOP CHORD Structural wood sheathing directly applied or 1-4-8 oc purlins, except end verticals.
BOT CHORD Rigid ceiling directly applied or 10-0-0 oc bracing.

REACTIONS (size) 3= Mechanical, 4=0-3-8
Max Grav 3=130 (LC 1), 4=118 (LC 1)

FORCES (lb) - Maximum Compression/Maximum Tension

TOP CHORD 1-4=-114/0, 2-3=-126/0, 1-2=0/0
BOT CHORD 3-4=0/0
WEBS 1-3=0/0

NOTES

- 1) Refer to girder(s) for truss to truss connections.
- 2) This truss is designed in accordance with the 2018 International Residential Code sections R502.11.1 and R802.10.2 and referenced standard ANSI/TPI 1.
- 3) Recommend 2x6 strongbacks, on edge, spaced at 10-00-00 oc and fastened to each truss with 3-10d (0.131" X 3") nails. Strongbacks to be attached to walls at their outer ends or restrained by other means.
- 4) Use Simpson Strong-Tie THA422 (Single Chord Girder) or equivalent at 0-8-12 from the left end to connect truss (es) to front face of top chord.
- 5) Fill all nail holes where hanger is in contact with lumber.
- 6) In the LOAD CASE(S) section, loads applied to the face of the truss are noted as front (F) or back (B).

LOAD CASE(S) Standard

- 1) Dead + Floor Live (balanced): Lumber Increase=1.00, Plate Increase=1.00
Uniform Loads (lb/ft)
Vert: 3-4=-7, 1-2=-67
Concentrated Loads (lb)
Vert: 5=-166 (F)

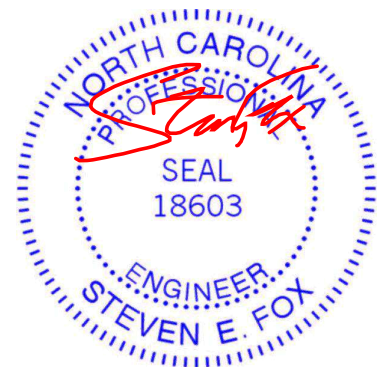

February 27, 2024

WARNING - Verify design parameters and READ NOTES ON THIS AND INCLUDED MITEK REFERENCE PAGE MII-7473 rev. 1/2/2023 BEFORE USE.

Design valid for use only with MiTek® connectors. This design is based only upon parameters shown, and is for an individual building component, not a truss system. Before use, the building designer must verify the applicability of design parameters and properly incorporate this design into the overall building design. Bracing indicated is to prevent buckling of individual truss web and/or chord members only. Additional temporary and permanent bracing is always required for stability and to prevent collapse with possible personal injury and property damage. For general guidance regarding the fabrication, storage, delivery, erection and bracing of trusses and truss systems, see **ANSI/TPI1 Quality Criteria and DSB-22** available from Truss Plate Institute (www.tpinst.org) and **BCSI Building Component Safety Information** available from the Structural Building Component Association (www.sbcacomponents.com)

ENGINEERING BY
TRENCO
A MiTek Affiliate

818 Soundside Road
Edenton, NC 27932

Job 24020110	Truss FW14	Truss Type Floor Supported Gable	Qty 1	Ply 1	DRB - 71 FaNC Job Reference (optional)	163855473
-----------------	---------------	-------------------------------------	----------	----------	---	-----------

Carter Components (Sanford, NC), Sanford, NC - 27332,

Run: 8.63 S Nov 1 2023 Print: 8.630 S Nov 1 2023 MiTek Industries, Inc. Mon Feb 26 11:35:18
ID:PjhB_nc1URtonv7Xw1AJpznBzd-RfC?PsB70Hq3NSgPqnL8w3ulTXbGKWrCDoi7J4zJC?f

Page: 1

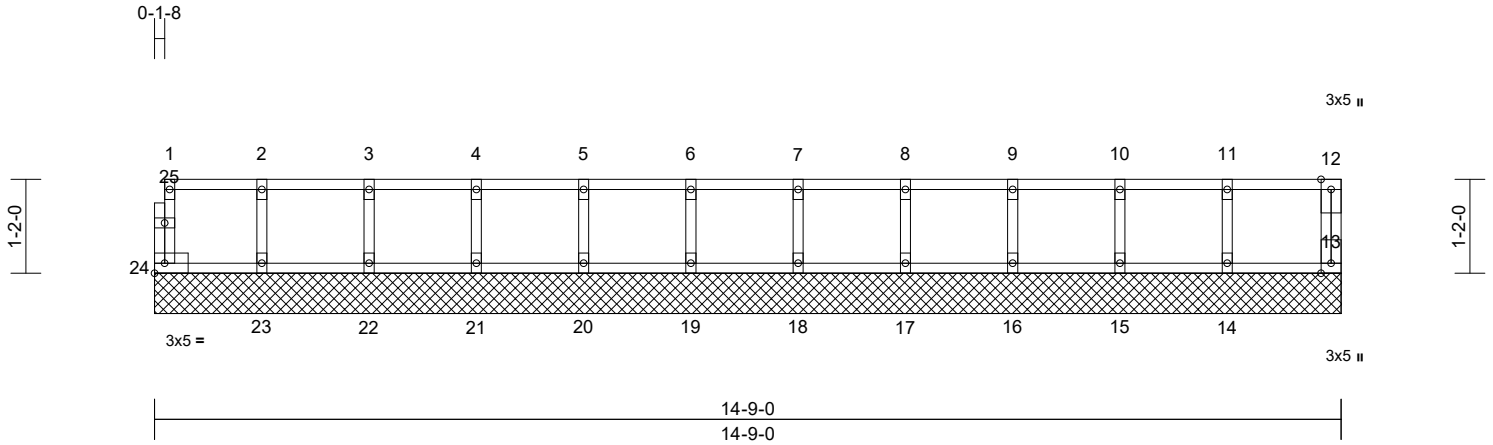

Scale = 1:28.6

Loading	(psf)	Spacing	1-4-0	CSI	DEFL	in	(loc)	l/defl	L/d	PLATES	GRIP
TCLL	40.0	Plate Grip DOL	1.00	TC	0.05	n/a	-	n/a	999	MT20	244/190
TCDL	10.0	Lumber DOL	1.00	BC	0.01	n/a	-	n/a	999		
BCLL	0.0	Rep Stress Incr	YES	WB	0.02	0.00	13	n/a	n/a		
BCDL	5.0	Code	IRC2018/TPI2014	Matrix-MR						Weight: 63 lb	FT = 20%F, 11%E

LUMBER

TOP CHORD 2x4 SP No.2(flat)
BOT CHORD 2x4 SP No.2(flat)
WEBS 2x4 SP No.3(flat)
OTHERS 2x4 SP No.3(flat)

BRACING

TOP CHORD Structural wood sheathing directly applied or 6-0-0 oc purlins, except end verticals.
BOT CHORD Rigid ceiling directly applied or 10-0-0 oc bracing.

REACTIONS (size) 13=14-9-0, 14=14-9-0, 15=14-9-0, 16=14-9-0, 17=14-9-0, 18=14-9-0, 19=14-9-0, 20=14-9-0, 21=14-9-0, 22=14-9-0, 23=14-9-0, 24=14-9-0
Max Grav 13=45 (LC 1), 14=99 (LC 1), 15=98 (LC 1), 16=98 (LC 1), 17=98 (LC 1), 18=98 (LC 1), 19=98 (LC 1), 20=98 (LC 1), 21=98 (LC 1), 22=99 (LC 1), 23=94 (LC 1), 24=38 (LC 1)

FORCES

(lb) - Maximum Compression/Maximum Tension
TOP CHORD 1-24=-34/0, 12-13=-41/0, 1-2=-7/0, 2-3=-7/0, 3-4=-7/0, 4-5=-7/0, 5-6=-7/0, 6-7=-7/0, 7-8=-7/0, 8-9=-7/0, 9-10=-7/0, 10-11=-7/0, 11-12=-7/0
BOT CHORD 23-24=0/7, 22-23=0/7, 21-22=0/7, 20-21=0/7, 19-20=0/7, 18-19=0/7, 17-18=0/7, 16-17=0/7, 15-16=0/7, 14-15=0/7, 13-14=0/7
WEBS 2-23=-86/0, 3-22=-90/0, 4-21=-89/0, 5-20=-89/0, 6-19=-89/0, 7-18=-89/0, 8-17=-89/0, 9-16=-89/0, 10-15=-89/0, 11-14=-90/0

NOTES

- All plates are 1.5x3 MT20 unless otherwise indicated.
- Gable requires continuous bottom chord bearing.
- Truss to be fully sheathed from one face or securely braced against lateral movement (i.e. diagonal web).
- Gable studs spaced at 1-4-0 oc.

- This truss is designed in accordance with the 2018 International Residential Code sections R502.11.1 and R802.10.2 and referenced standard ANSI/TPI 1.
- Recommend 2x6 strongbacks, on edge, spaced at 10-00-00 oc and fastened to each truss with 3-10d (0.131" X 3") nails. Strongbacks to be attached to walls at their outer ends or restrained by other means.
- CAUTION, Do not erect truss backwards.

LOAD CASE(S) Standard

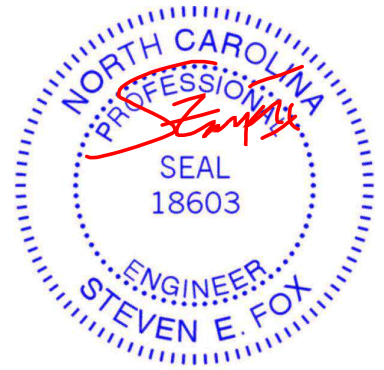

February 27, 2024

WARNING - Verify design parameters and READ NOTES ON THIS AND INCLUDED MITEK REFERENCE PAGE MII-7473 rev. 1/2/2023 BEFORE USE.

Design valid for use only with MiTek® connectors. This design is based only upon parameters shown, and is for an individual building component, not a truss system. Before use, the building designer must verify the applicability of design parameters and properly incorporate this design into the overall building design. Bracing indicated is to prevent buckling of individual truss web and/or chord members only. Additional temporary and permanent bracing is always required for stability and to prevent collapse with possible personal injury and property damage. For general guidance regarding the fabrication, storage, delivery, erection and bracing of trusses and truss systems, see **ANSI/TPI1 Quality Criteria and DSB-22** available from Truss Plate Institute (www.tpinst.org) and **BCSI Building Component Safety Information** available from the Structural Building Component Association (www.sbcacomponents.com)



818 Soundside Road
Edenton, NC 27932

Job 24020110	Truss FW14A	Truss Type Floor Supported Gable	Qty 1	Ply 1	DRB - 71 FaNC Job Reference (optional)	163855474
-----------------	----------------	-------------------------------------	----------	----------	---	-----------

Carter Components (Sanford, NC), Sanford, NC - 27332,

Run: 8.63 S Nov 1 2023 Print: 8.630 S Nov 1 2023 MiTek Industries, Inc. Mon Feb 26 11:35:18
ID:qINJcpfvmMGMeNs6bAj01PznBZA-RfC?PsB70Hq3NSgPqnL8w3ulTXbGKWrCDoi7J4zJC?f

Page: 1

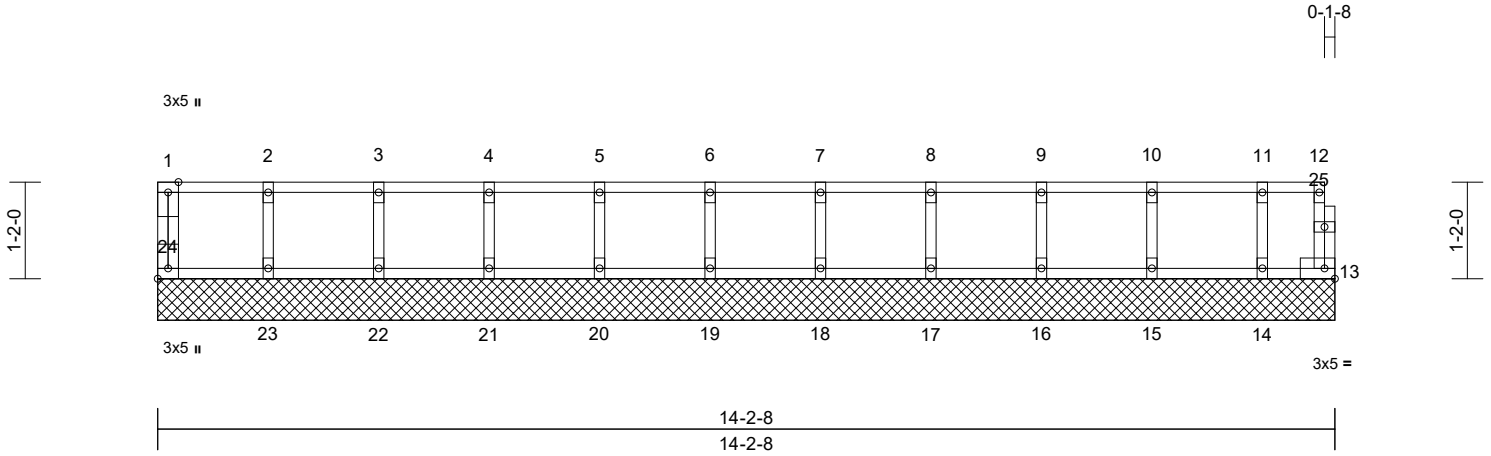

Scale = 1:27.8

Plate Offsets (X, Y): [24:Edge,0-1-8]

Loading	(psf)	Spacing	1-4-0	CSI	DEFL	in	(loc)	l/defl	L/d	PLATES	GRIP	
TCLL	40.0	Plate Grip DOL	1.00	TC	0.05	Vert(LL)	n/a	-	n/a	999	MT20	244/190
TCDL	10.0	Lumber DOL	1.00	BC	0.01	Vert(TL)	n/a	-	n/a	999		
BCLL	0.0	Rep Stress Incr	YES	WB	0.02	Horiz(TL)	0.00	13	n/a	n/a		
BCDL	5.0	Code	IRC2018/TPI2014	Matrix-MR							Weight: 61 lb	FT = 20%F, 11%E

LUMBER

- TOP CHORD 2x4 SP No.2(flat)
- BOT CHORD 2x4 SP No.2(flat)
- WEBS 2x4 SP No.3(flat)
- OTHERS 2x4 SP No.3(flat)

BRACING

- TOP CHORD Structural wood sheathing directly applied or 6-0-0 oc purlins, except end verticals.
- BOT CHORD Rigid ceiling directly applied or 10-0-0 oc bracing.

REACTIONS (size)

- 13=14-2-8, 14=14-2-8, 15=14-2-8, 16=14-2-8, 17=14-2-8, 18=14-2-8, 19=14-2-8, 20=14-2-8, 21=14-2-8, 22=14-2-8, 23=14-2-8, 24=14-2-8
- Max Grav 13=20 (LC 1), 14=77 (LC 1), 15=102 (LC 1), 16=97 (LC 1), 17=98 (LC 1), 18=98 (LC 1), 19=98 (LC 1), 20=98 (LC 1), 21=98 (LC 1), 22=98 (LC 1), 23=98 (LC 1), 24=39 (LC 1)

FORCES (lb) - Maximum Compression/Maximum Tension

- TOP CHORD 1-24=-36/0, 12-13=-16/0, 1-2=-4/0, 2-3=-4/0, 3-4=-4/0, 4-5=-4/0, 5-6=-4/0, 6-7=-4/0, 7-8=-4/0, 8-9=-4/0, 9-10=-4/0, 10-11=-4/0, 11-12=-4/0
- BOT CHORD 23-24=0/4, 22-23=0/4, 21-22=0/4, 20-21=0/4, 19-20=0/4, 18-19=0/4, 17-18=0/4, 16-17=0/4, 15-16=0/4, 14-15=0/4, 13-14=0/4
- WEBS 2-23=-88/0, 3-22=-89/0, 4-21=-89/0, 5-20=-89/0, 6-19=-89/0, 7-18=-89/0, 8-17=-89/0, 9-16=-88/0, 10-15=-92/0, 11-14=-72/0

NOTES

- All plates are 1.5x3 MT20 unless otherwise indicated.
- Gable requires continuous bottom chord bearing.
- Truss to be fully sheathed from one face or securely braced against lateral movement (i.e. diagonal web).

- Gable studs spaced at 1-4-0 oc.
- This truss is designed in accordance with the 2018 International Residential Code sections R502.11.1 and R802.10.2 and referenced standard ANSI/TPI 1.
- Recommend 2x6 strongbacks, on edge, spaced at 10-00-00 oc and fastened to each truss with 3-10d (0.131" X 3") nails. Strongbacks to be attached to walls at their outer ends or restrained by other means.
- CAUTION, Do not erect truss backwards.

LOAD CASE(S) Standard

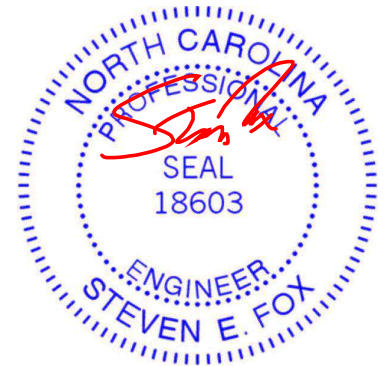

February 27, 2024

WARNING - Verify design parameters and READ NOTES ON THIS AND INCLUDED MITEK REFERENCE PAGE MII-7473 rev. 1/2/2023 BEFORE USE.

Design valid for use only with MiTek® connectors. This design is based only upon parameters shown, and is for an individual building component, not a truss system. Before use, the building designer must verify the applicability of design parameters and properly incorporate this design into the overall building design. Bracing indicated is to prevent buckling of individual truss web and/or chord members only. Additional temporary and permanent bracing is always required for stability and to prevent collapse with possible personal injury and property damage. For general guidance regarding the fabrication, storage, delivery, erection and bracing of trusses and truss systems, see **ANSI/TPI1 Quality Criteria and DSB-22** available from Truss Plate Institute (www.tpinst.org) and **BCSI Building Component Safety Information** available from the Structural Building Component Association (www.sbccomponents.com)



818 Soundside Road
Edenton, NC 27932

Job 24020110	Truss FW19	Truss Type Floor Supported Gable	Qty 1	Ply 1	DRB - 71 FaNC Job Reference (optional)	163855475
-----------------	---------------	-------------------------------------	----------	----------	---	-----------

Carter Components (Sanford, NC), Sanford, NC - 27332,

Run: 8.63 S Nov 1 2023 Print: 8.630 S Nov 1 2023 MiTek Industries, Inc. Mon Feb 26 11:35:18
ID:Et2SFqho3HexVqagHijf1znBZX-RfC?PsB70Hq3NSgPqnL8w3ulTXbGKWRCDoi7J4zJC?f

Page: 1

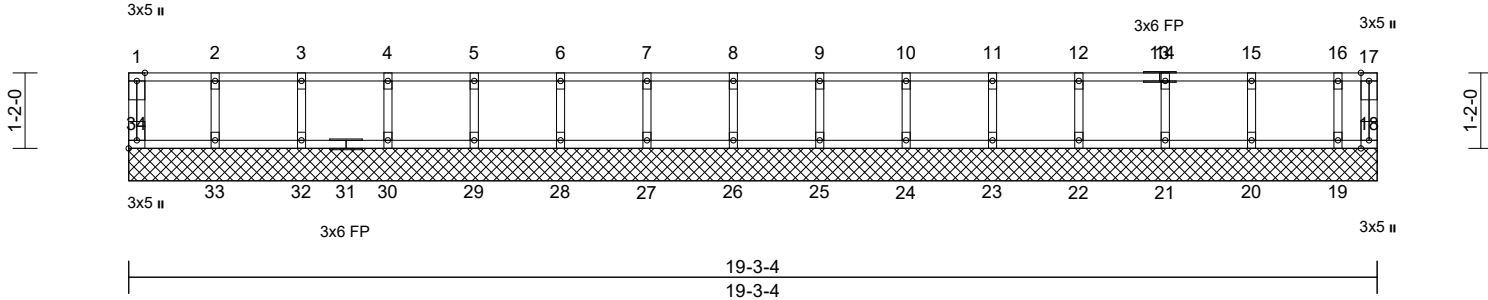

Scale = 1:35.6

Plate Offsets (X, Y): [34:Edge,0-1-8]

Loading	(psf)	Spacing	1-4-0	CSI	DEFL	in	(loc)	l/defl	L/d	PLATES	GRIP	
TCLL	40.0	Plate Grip DOL	1.00	TC	0.05	Vert(LL)	n/a	-	n/a	999	MT20	244/190
TCDL	10.0	Lumber DOL	1.00	BC	0.01	Vert(TL)	n/a	-	n/a	999		
BCLL	0.0	Rep Stress Incr	YES	WB	0.02	Horiz(TL)	0.00	18	n/a	n/a		
BCDL	5.0	Code	IRC2018/TPI2014	Matrix-MR							Weight: 82 lb	FT = 20%F, 11%E

LUMBER

TOP CHORD 2x4 SP No.2(flat)
BOT CHORD 2x4 SP No.2(flat)
WEBS 2x4 SP No.3(flat)
OTHERS 2x4 SP No.3(flat)

BRACING

TOP CHORD Structural wood sheathing directly applied or 6-0-0 oc purlins, except end verticals.
BOT CHORD Rigid ceiling directly applied or 10-0-0 oc bracing.

REACTIONS (size) 18=19-3-4, 19=19-3-4, 20=19-3-4, 21=19-3-4, 22=19-3-4, 23=19-3-4, 24=19-3-4, 25=19-3-4, 26=19-3-4, 27=19-3-4, 28=19-3-4, 29=19-3-4, 30=19-3-4, 32=19-3-4, 33=19-3-4, 34=19-3-4

Max Grav 18=11 (LC 1), 19=69 (LC 1), 20=102 (LC 1), 21=97 (LC 1), 22=98 (LC 1), 23=98 (LC 1), 24=98 (LC 1), 25=98 (LC 1), 26=98 (LC 1), 27=98 (LC 1), 28=98 (LC 1), 29=98 (LC 1), 30=98 (LC 1), 32=98 (LC 1), 33=99 (LC 1), 34=39 (LC 1)

FORCES

(lb) - Maximum Compression/Maximum Tension

TOP CHORD 1-34=-36/0, 17-18=-6/0, 1-2=-4/0, 2-3=-4/0, 3-4=-4/0, 4-5=-4/0, 5-6=-4/0, 6-7=-4/0, 7-8=-4/0, 8-9=-4/0, 9-10=-4/0, 10-11=-4/0, 11-12=-4/0, 12-14=-4/0, 14-15=-4/0, 15-16=-4/0, 16-17=-4/0
BOT CHORD 33-34=0/4, 32-33=0/4, 30-32=0/4, 29-30=0/4, 28-29=0/4, 27-28=0/4, 26-27=0/4, 25-26=0/4, 24-25=0/4, 23-24=0/4, 22-23=0/4, 21-22=0/4, 20-21=0/4, 19-20=0/4, 18-19=0/4
WEBS 2-33=-89/0, 3-32=-89/0, 4-30=-89/0, 5-29=-89/0, 6-28=-89/0, 7-27=-89/0, 8-26=-89/0, 9-25=-89/0, 10-24=-89/0, 11-23=-89/0, 12-22=-89/0, 14-21=-88/0, 15-20=-92/0, 16-19=-68/0

NOTES

- 1) All plates are 1.5x3 MT20 unless otherwise indicated.
- 2) Gable requires continuous bottom chord bearing.
- 3) Truss to be fully sheathed from one face or securely braced against lateral movement (i.e. diagonal web).
- 4) Gable studs spaced at 1-4-0 oc.
- 5) This truss is designed in accordance with the 2018 International Residential Code sections R502.11.1 and R802.10.2 and referenced standard ANSI/TPI 1.
- 6) Recommend 2x6 strongbacks, on edge, spaced at 10-00-00 oc and fastened to each truss with 3-10d (0.131" X 3") nails. Strongbacks to be attached to walls at their outer ends or restrained by other means.

LOAD CASE(S) Standard

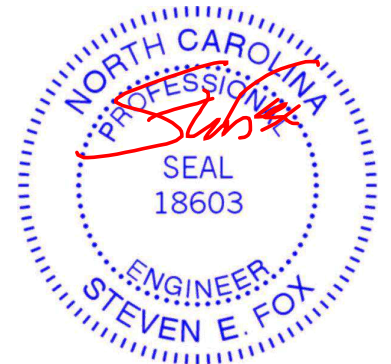

February 27, 2024

WARNING - Verify design parameters and READ NOTES ON THIS AND INCLUDED MITEK REFERENCE PAGE MII-7473 rev. 1/2/2023 BEFORE USE.

Design valid for use only with MiTek® connectors. This design is based only upon parameters shown, and is for an individual building component, not a truss system. Before use, the building designer must verify the applicability of design parameters and properly incorporate this design into the overall building design. Bracing indicated is to prevent buckling of individual truss web and/or chord members only. Additional temporary and permanent bracing is always required for stability and to prevent collapse with possible personal injury and property damage. For general guidance regarding the fabrication, storage, delivery, erection and bracing of trusses and truss systems, see **ANSI/TPI1 Quality Criteria and DSB-22** available from Truss Plate Institute (www.tpinst.org) and **BCSI Building Component Safety Information** available from the Structural Building Component Association (www.sbcacomponents.com)



818 Soundside Road
Edenton, NC 27932

Job 24020110	Truss FW20	Truss Type Floor Supported Gable	Qty 1	Ply 1	DRB - 71 FaNC Job Reference (optional)	163855476
-----------------	---------------	-------------------------------------	----------	----------	---	-----------

Carter Components (Sanford, NC), Sanford, NC - 27332,

Run: 8.63 S Nov 1 2023 Print: 8.630 S Nov 1 2023 MiTek Industries, Inc. Mon Feb 26 11:35:18
ID:Q_DcYbphTf0NJXwoQ6zlbMznBZM-RfC?PsB70Hq3NSgPqnL8w3uITXbGKWrCDoi7J4zJC?f

Page: 1

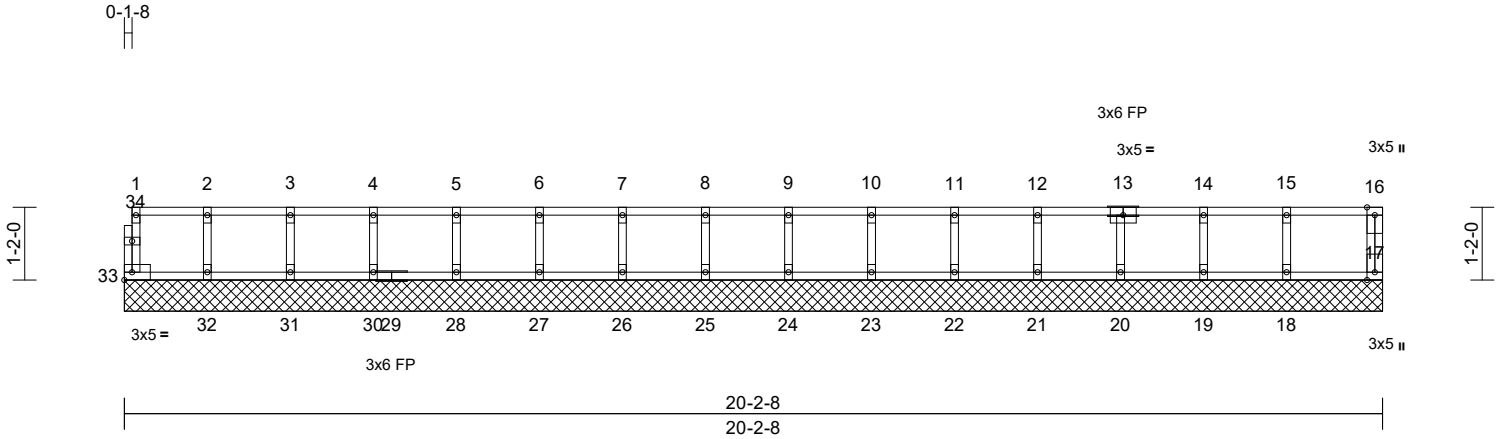

Scale = 1:37

Loading	(psf)	Spacing	1-4-0	CSI	DEFL	in	(loc)	l/defl	L/d	PLATES	GRIP	
TCLL	40.0	Plate Grip DOL	1.00	TC	0.06	Vert(LL)	n/a	-	n/a	999	MT20	244/190
TCDL	10.0	Lumber DOL	1.00	BC	0.01	Vert(TL)	n/a	-	n/a	999		
BCLL	0.0	Rep Stress Incr	YES	WB	0.02	Horiz(TL)	0.00	17	n/a	n/a		
BCDL	5.0	Code	IRC2018/TPI2014	Matrix-MR							Weight: 84 lb	FT = 20%F, 11%E

LUMBER
TOP CHORD 2x4 SP No.2(flat)
BOT CHORD 2x4 SP No.2(flat)
WEBS 2x4 SP No.3(flat)
OTHERS 2x4 SP No.3(flat)

BRACING
TOP CHORD Structural wood sheathing directly applied or 6-0-0 oc purlins, except end verticals.
BOT CHORD Rigid ceiling directly applied or 10-0-0 oc bracing.

REACTIONS (size) 17=20-2-8, 18=20-2-8, 19=20-2-8, 20=20-2-8, 21=20-2-8, 22=20-2-8, 23=20-2-8, 24=20-2-8, 25=20-2-8, 26=20-2-8, 27=20-2-8, 28=20-2-8, 30=20-2-8, 31=20-2-8, 32=20-2-8, 33=20-2-8
Max Grav 17=51 (LC 1), 18=103 (LC 1), 19=94 (LC 1), 20=98 (LC 1), 21=100 (LC 1), 22=97 (LC 1), 23=98 (LC 1), 24=98 (LC 1), 25=98 (LC 1), 26=98 (LC 1), 27=98 (LC 1), 28=98 (LC 1), 30=98 (LC 1), 31=99 (LC 1), 32=95 (LC 1), 33=38 (LC 1)

FORCES (lb) - Maximum Compression/Maximum Tension
TOP CHORD 1-33=-34/0, 16-17=-46/0, 1-2=-7/0, 2-3=-7/0, 3-4=-7/0, 4-5=-7/0, 5-6=-7/0, 6-7=-7/0, 7-8=-7/0, 8-9=-7/0, 9-10=-7/0, 10-11=-7/0, 11-12=-7/0, 12-14=-10/0, 14-15=-10/0, 15-16=-10/0
BOT CHORD 32-33=0/7, 31-32=0/7, 30-31=0/7, 28-30=0/7, 27-28=0/7, 26-27=0/7, 25-26=0/7, 24-25=0/7, 23-24=0/7, 22-23=0/7, 21-22=0/7, 20-21=0/7, 19-20=0/10, 18-19=0/10, 17-18=0/10
WEBS 2-32=-87/0, 3-31=-90/0, 4-30=-89/0, 5-28=-89/0, 6-27=-89/0, 7-26=-89/0, 8-25=-89/0, 9-24=-89/0, 10-23=-89/0, 11-22=-88/0, 12-21=-91/0, 13-20=-89/0, 14-19=-85/0, 15-18=-94/0

NOTES

- 1) All plates are 1.5x3 MT20 unless otherwise indicated.
- 2) Gable requires continuous bottom chord bearing.
- 3) Truss to be fully sheathed from one face or securely braced against lateral movement (i.e. diagonal web).
- 4) Gable studs spaced at 1-4-0 oc.
- 5) This truss is designed in accordance with the 2018 International Residential Code sections R502.11.1 and R802.10.2 and referenced standard ANSI/TPI 1.
- 6) Recommend 2x6 strongbacks, on edge, spaced at 10-00-00 oc and fastened to each truss with 3-10d (0.131" X 3") nails. Strongbacks to be attached to walls at their outer ends or restrained by other means.
- 7) CAUTION, Do not erect truss backwards.

LOAD CASE(S) Standard



February 27, 2024

WARNING - Verify design parameters and READ NOTES ON THIS AND INCLUDED MITEK REFERENCE PAGE MII-7473 rev. 1/2/2023 BEFORE USE.

Design valid for use only with MiTek® connectors. This design is based only upon parameters shown, and is for an individual building component, not a truss system. Before use, the building designer must verify the applicability of design parameters and properly incorporate this design into the overall building design. Bracing indicated is to prevent buckling of individual truss web and/or chord members only. Additional temporary and permanent bracing is always required for stability and to prevent collapse with possible personal injury and property damage. For general guidance regarding the fabrication, storage, delivery, erection and bracing of trusses and truss systems, see **ANSI/TPI1 Quality Criteria and DSB-22** available from Truss Plate Institute (www.tpinst.org) and **BCSI Building Component Safety Information** available from the Structural Building Component Association (www.sbcacomponents.com)



818 Soundside Road
Edenton, NC 27932

Job 24020110	Truss PB1	Truss Type Piggyback	Qty 12	Ply 1	DRB - 71 FaNC Job Reference (optional)	163855477
-----------------	--------------	-------------------------	-----------	----------	---	-----------

Carter Components (Sanford, NC), Sanford, NC - 27332,

Run: 8.63 S Nov 1 2023 Print: 8.630 S Nov 1 2023 MiTek Industries, Inc. Mon Feb 26 11:35:18
ID:kA8RvPcE13INZ6lZX7XyQlZypGJ-RfC?PsB70Hq3NSgPqnl8w3ulTXbGKWrCDoi7J4zJC?F

Page: 1

-0-9-12	3-1-13	6-3-11	7-1-7
0-9-12	3-1-13	3-1-13	0-9-12

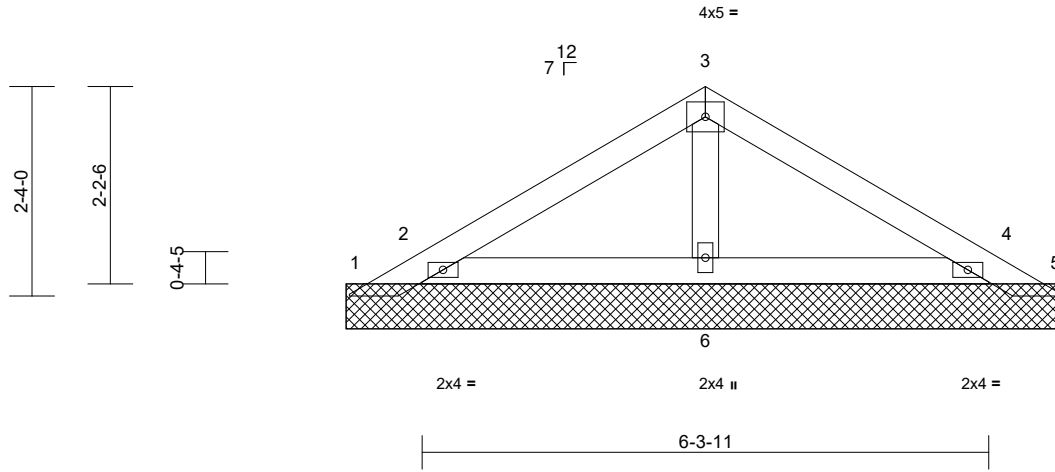

Scale = 1:25.6

Loading	(psf)	Spacing	1-11-4	CSI	DEFL	in	(loc)	l/defl	L/d	PLATES	GRIP	
TCLL (roof)	20.0	Plate Grip DOL	1.15	TC	0.23	Vert(LL)	n/a	-	n/a	999	MT20	244/190
Snow (Pf)	20.0	Lumber DOL	1.15	BC	0.08	Vert(TL)	n/a	-	n/a	999		
TCDL	10.0	Rep Stress Incr	YES	WB	0.02	Horiz(TL)	0.00	4	n/a	n/a		
BCLL	0.0*	Code	IRC2018/TPI2014	Matrix-MP								
BCDL	10.0										Weight: 25 lb	FT = 20%

LUMBER
TOP CHORD 2x4 SP No.2
BOT CHORD 2x4 SP No.2
OTHERS 2x4 SP No.3

BRACING
TOP CHORD Structural wood sheathing directly applied or 6-0-0 oc purlins.
BOT CHORD Rigid ceiling directly applied or 10-0-0 oc bracing.

REACTIONS (size) 1=8-0-0, 2=8-0-0, 4=8-0-0, 5=8-0-0, 6=8-0-0, 7=8-0-0, 10=8-0-0
Max Horiz 1=-49 (LC 12)
Max Uplift 1=-151 (LC 21), 2=-88 (LC 14), 4=-84 (LC 15), 5=-149 (LC 22), 7=-88 (LC 14), 10=-84 (LC 15)
Max Grav 1=58 (LC 14), 2=435 (LC 21), 4=422 (LC 22), 5=42 (LC 15), 6=192 (LC 21), 7=435 (LC 21), 10=422 (LC 22)

FORCES (lb) - Maximum Compression/Maximum Tension
TOP CHORD 1-2=-61/115, 2-3=-107/64, 3-4=-107/64, 4-5=-36/105
BOT CHORD 2-6=-54/39, 4-6=-55/39
WEBS 3-6=-102/32

NOTES
1) Unbalanced roof live loads have been considered for this design.
2) Wind: ASCE 7-16; Vult=130mph (3-second gust) Vasd=103mph; TCDL=6.0psf; BCCL=6.0psf; h=25ft; Cat. II; Exp B; Enclosed; MWFRS (envelope) exterior zone and C-C Exterior(2E) 0-3-11 to 3-3-11, Exterior(2R) 3-3-11 to 4-8-5, Exterior(2E) 4-8-5 to 7-8-5 zone; cantilever left and right exposed ; end vertical left and right exposed;C-C for members and forces & MWFRS for reactions shown; Lumber DOL=1.60 plate grip DOL=1.60

- Truss designed for wind loads in the plane of the truss only. For studs exposed to wind (normal to the face), see Standard Industry Gable End Details as applicable, or consult qualified building designer as per ANSI/TPI 1.
- TCLL: ASCE 7-16; Pr=20.0 psf (roof LL: Lum DOL=1.15 Plate DOL=1.15); Pf=20.0 psf (Lum DOL=1.15 Plate DOL=1.15); Is=1.0; Rough Cat B; Fully Exp.; Ce=0.9; Cs=1.00; Ct=1.10
- Unbalanced snow loads have been considered for this design.
- Gable requires continuous bottom chord bearing.
- Gable studs spaced at 2-0-0 oc.
- This truss has been designed for a 10.0 psf bottom chord live load nonconcurrent with any other live loads.
- * This truss has been designed for a live load of 20.0psf on the bottom chord in all areas where a rectangle 3-06-00 tall by 2-00-00 wide will fit between the bottom chord and any other members.
- Provide mechanical connection (by others) of truss to bearing plate capable of withstanding 151 lb uplift at joint 1 and 149 lb uplift at joint 5.
- N/A
- This truss is designed in accordance with the 2018 International Residential Code sections R502.11.1 and R802.10.2 and referenced standard ANSI/TPI 1.
- See Standard Industry Piggyback Truss Connection Detail for Connection to base truss as applicable, or consult qualified building designer.

LOAD CASE(S) Standard

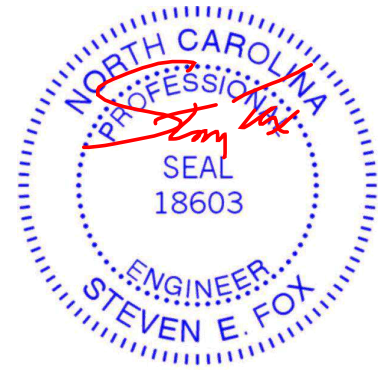

February 27, 2024

WARNING - Verify design parameters and READ NOTES ON THIS AND INCLUDED MITEK REFERENCE PAGE MII-7473 rev. 1/2/2023 BEFORE USE.

Design valid for use only with MiTek® connectors. This design is based only upon parameters shown, and is for an individual building component, not a truss system. Before use, the building designer must verify the applicability of design parameters and properly incorporate this design into the overall building design. Bracing indicated is to prevent buckling of individual truss web and/or chord members only. Additional temporary and permanent bracing is always required for stability and to prevent collapse with possible personal injury and property damage. For general guidance regarding the fabrication, storage, delivery, erection and bracing of trusses and truss systems, see **ANSI/TPI1 Quality Criteria and DSB-22** available from Truss Plate Institute (www.tpinst.org) and **BCSI Building Component Safety Information** available from the Structural Building Component Association (www.sbcacomponents.com)



818 Soundside Road
Edenton, NC 27932

Job 24020110	Truss V04	Truss Type Valley	Qty 1	Ply 1	DRB - 71 FaNC Job Reference (optional)	163855478
-----------------	--------------	----------------------	----------	----------	---	-----------

Carter Components (Sanford, NC), Sanford, NC - 27332,

Run: 8.63 S Nov 1 2023 Print: 8.630 S Nov 1 2023 MiTek Industries, Inc. Mon Feb 26 11:35:19
ID:ELGZLWFI13TUL_d3dxyYyGzhIFC-RfC?PsB70Hq3NSgPqnL8w3ulTXbGKWrCDoi7J4zJC?F

Page: 1

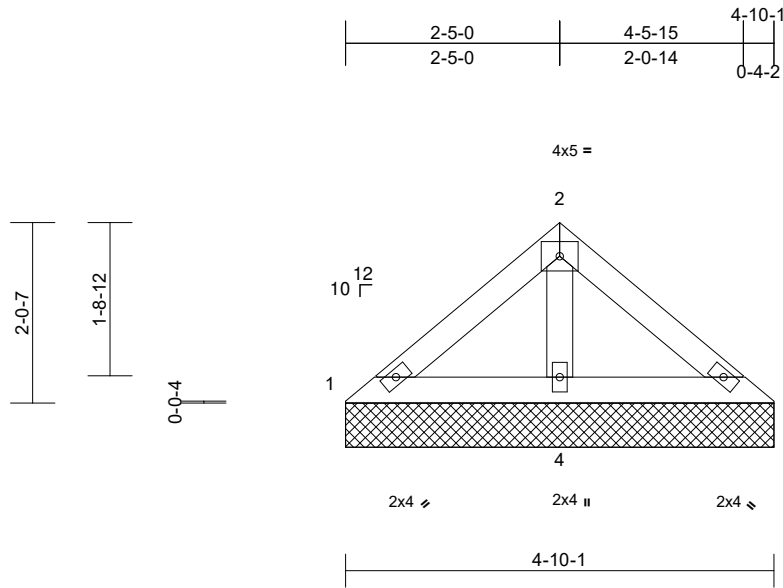

Scale = 1:26

Loading	(psf)	Spacing	2-0-0	CSI	DEFL	in	(loc)	l/defl	L/d	PLATES	GRIP	
TCLL (roof)	20.0	Plate Grip DOL	1.15	TC	0.11	Vert(LL)	n/a	-	n/a	999	MT20	244/190
Snow (Pf)	20.0	Lumber DOL	1.15	BC	0.10	Vert(TL)	n/a	-	n/a	999		
TCDL	10.0	Rep Stress Incr	YES	WB	0.08	Horiz(TL)	0.00	3	n/a	n/a		
BCLL	0.0*	Code	IRC2018/TPI2014	Matrix-MP								
BCDL	10.0											
										Weight: 17 lb	FT = 20%	

LUMBER

TOP CHORD 2x4 SP No.2
BOT CHORD 2x4 SP No.2
OTHERS 2x4 SP No.3

BRACING

TOP CHORD Structural wood sheathing directly applied or 4-10-1 oc purlins.
BOT CHORD Rigid ceiling directly applied or 6-0-0 oc bracing.

REACTIONS

(size) 1=4-10-1, 3=4-10-1, 4=4-10-1,
9=4-10-1
Max Horiz 1=43 (LC 11)
Max Uplift 1=-73 (LC 21), 4=-31 (LC 15)
Max Grav 1=73 (LC 20), 3=0 (LC 13), 4=470
(LC 21), 9=0 (LC 13)

FORCES

(lb) - Maximum Compression/Maximum Tension

TOP CHORD 1-2=-57/234, 2-3=-116/263
BOT CHORD 1-4=-174/106, 3-4=-186/115
WEBS 2-4=-378/127

NOTES

- Unbalanced roof live loads have been considered for this design.
- Wind: ASCE 7-16; Vult=130mph (3-second gust)
Vasd=103mph; TCDL=6.0psf; BCDL=6.0psf; h=25ft;
Cat. II; Exp B; Enclosed; MWFRS (envelope) exterior zone and C-C Exterior(2E) zone; cantilever left and right exposed ; end vertical left and right exposed;C-C for members and forces & MWFRS for reactions shown; Lumber DOL=1.60 plate grip DOL=1.60
- Truss designed for wind loads in the plane of the truss only. For studs exposed to wind (normal to the face), see Standard Industry Gable End Details as applicable, or consult qualified building designer as per ANSI/TPI 1.
- TCLL: ASCE 7-16; Pr=20.0 psf (roof LL: Lum DOL=1.15 Plate DOL=1.15); Pf=20.0 psf (Lum DOL=1.15 Plate DOL=1.15); Is=1.0; Rough Cat B; Fully Exp.; Ce=0.9; Cs=1.00; Ct=1.10

- Unbalanced snow loads have been considered for this design.
- Gable requires continuous bottom chord bearing.
- Gable studs spaced at 4-0-0 oc.
- This truss has been designed for a 10.0 psf bottom chord live load nonconcurrent with any other live loads.
- * This truss has been designed for a live load of 20.0psf on the bottom chord in all areas where a rectangle 3-06-00 tall by 2-00-00 wide will fit between the bottom chord and any other members.
- Provide mechanical connection (by others) of truss to bearing plate capable of withstanding 73 lb uplift at joint 1 and 31 lb uplift at joint 4.
- This truss is designed in accordance with the 2018 International Residential Code sections R502.11.1 and R802.10.2 and referenced standard ANSI/TPI 1.

LOAD CASE(S) Standard



February 27, 2024

WARNING - Verify design parameters and READ NOTES ON THIS AND INCLUDED MITEK REFERENCE PAGE MII-7473 rev. 1/2/2023 BEFORE USE.

Design valid for use only with MiTek® connectors. This design is based only upon parameters shown, and is for an individual building component, not a truss system. Before use, the building designer must verify the applicability of design parameters and properly incorporate this design into the overall building design. Bracing indicated is to prevent buckling of individual truss web and/or chord members only. Additional temporary and permanent bracing is always required for stability and to prevent collapse with possible personal injury and property damage. For general guidance regarding the fabrication, storage, delivery, erection and bracing of trusses and truss systems, see **ANSI/TPI1 Quality Criteria and DSB-22** available from Truss Plate Institute (www.tpinst.org) and **BCSI Building Component Safety Information** available from the Structural Building Component Association (www.sbcacomponents.com)

ENGINEERING BY
TRENCO
A MiTek Affiliate

818 Soundside Road
Edenton, NC 27932

Job 24020110	Truss V07	Truss Type Valley	Qty 1	Ply 1	DRB - 71 FaNC Job Reference (optional)	163855479
-----------------	--------------	----------------------	----------	----------	---	-----------

Carter Components (Sanford, NC), Sanford, NC - 27332,

Run: 8.63 S Nov 1 2023 Print: 8.630 S Nov 1 2023 MiTek Industries, Inc. Mon Feb 26 11:35:19
ID:qmaRjUDQ?85wUWuYpOrLezhIFF-RfC?PsB70Hq3NSgPqnL8w3uITXbGKwRcDoi7J4zJC?f

Page: 1

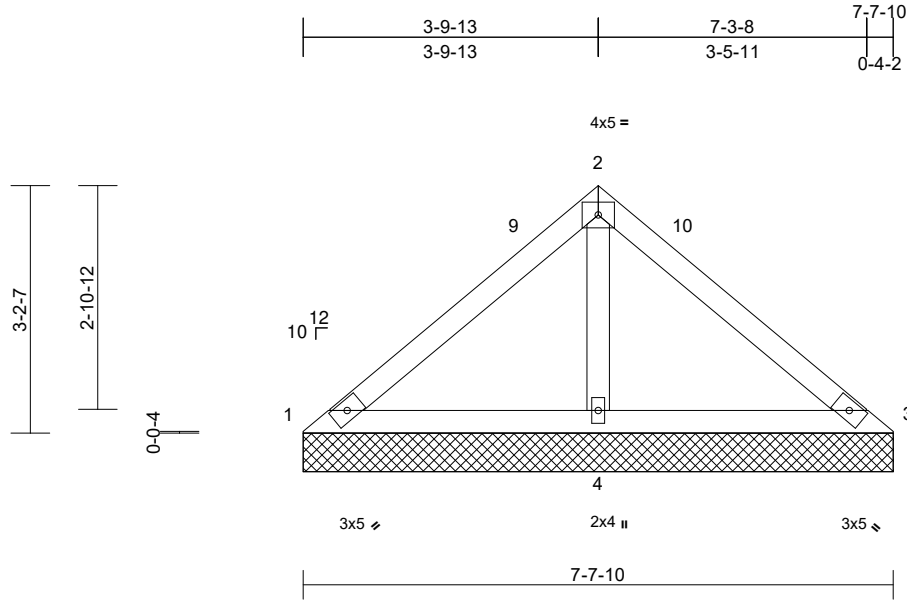

Loading	(psf)	Spacing	2-0-0	CSI	DEFL	in	(loc)	l/defl	L/d	PLATES	GRIP	
TCLL (roof)	20.0	Plate Grip DOL	1.15	TC	0.30	Vert(LL)	n/a	-	n/a	999	MT20	244/190
Snow (Pf)	20.0	Lumber DOL	1.15	BC	0.30	Vert(TL)	n/a	-	n/a	999		
TCDL	10.0	Rep Stress Incr	YES	WB	0.10	Horiz(TL)	0.00	4	n/a	n/a		
BCLL	0.0*	Code	IRC2018/TPI2014	Matrix-MP								
BCDL	10.0											
											Weight: 29 lb	FT = 20%

LUMBER
TOP CHORD 2x4 SP No.2
BOT CHORD 2x4 SP No.2
OTHERS 2x4 SP No.3

BRACING
TOP CHORD Structural wood sheathing directly applied or 7-7-10 oc purlins.
BOT CHORD Rigid ceiling directly applied or 6-0-0 oc bracing.

REACTIONS (size) 1=7-7-10, 3=7-7-10, 4=7-7-10
Max Horiz 1=-71 (LC 10)
Max Uplift 1=-26 (LC 21), 3=-26 (LC 20), 4=-82 (LC 14)
Max Grav 1=105 (LC 20), 3=105 (LC 21), 4=579 (LC 21)

FORCES (lb) - Maximum Compression/Maximum Tension
TOP CHORD 1-2=-99/255, 2-3=-99/255
BOT CHORD 1-4=-176/162, 3-4=-176/162
WEBS 2-4=-419/217

- TCLL: ASCE 7-16; Pr=20.0 psf (roof LL: Lum DOL=1.15 Plate DOL=1.15); Pf=20.0 psf (Lum DOL=1.15 Plate DOL=1.15); Is=1.0; Rough Cat B; Fully Exp.; Ce=0.9; Cs=1.00; Ct=1.10
- Unbalanced snow loads have been considered for this design.
- Gable requires continuous bottom chord bearing.
- Gable studs spaced at 4-0-0 oc.
- This truss has been designed for a 10.0 psf bottom chord live load nonconcurrent with any other live loads.
- * This truss has been designed for a live load of 20.0psf on the bottom chord in all areas where a rectangle 3-06-00 tall by 2-00-00 wide will fit between the bottom chord and any other members.
- Provide mechanical connection (by others) of truss to bearing plate capable of withstanding 26 lb uplift at joint 1, 26 lb uplift at joint 3 and 82 lb uplift at joint 4.
- This truss is designed in accordance with the 2018 International Residential Code sections R502.11.1 and R802.10.2 and referenced standard ANSI/TPI 1.

LOAD CASE(S) Standard

NOTES

- Unbalanced roof live loads have been considered for this design.
- Wind: ASCE 7-16; Vult=130mph (3-second gust) Vasd=103mph; TCDL=6.0psf; BCDL=6.0psf; h=25ft; Cat. II; Exp B; Enclosed; MWFRS (envelope) exterior zone and C-C Exterior(2E) 0-0-5 to 3-0-5, Exterior(2R) 3-0-5 to 4-7-15, Exterior(2E) 4-7-15 to 7-7-15 zone; cantilever left and right exposed; end vertical left and right exposed; C-C for members and forces & MWFRS for reactions shown; Lumber DOL=1.60 plate grip DOL=1.60
- Truss designed for wind loads in the plane of the truss only. For studs exposed to wind (normal to the face), see Standard Industry Gable End Details as applicable, or consult qualified building designer as per ANSI/TPI 1.



February 27, 2024

WARNING - Verify design parameters and READ NOTES ON THIS AND INCLUDED MITEK REFERENCE PAGE MII-7473 rev. 1/2/2023 BEFORE USE.

Design valid for use only with MiTek® connectors. This design is based only upon parameters shown, and is for an individual building component, not a truss system. Before use, the building designer must verify the applicability of design parameters and properly incorporate this design into the overall building design. Bracing indicated is to prevent buckling of individual truss web and/or chord members only. Additional temporary and permanent bracing is always required for stability and to prevent collapse with possible personal injury and property damage. For general guidance regarding the fabrication, storage, delivery, erection and bracing of trusses and truss systems, see **ANSI/TPI1 Quality Criteria and DSB-22** available from Truss Plate Institute (www.tpinst.org) and **BCSI Building Component Safety Information** available from the Structural Building Component Association (www.sbcacomponents.com)

ENGINEERING BY
TRENCO
A MiTek Affiliate

818 Soundside Road
Edenton, NC 27932

Job 24020110	Truss V10	Truss Type Valley	Qty 1	Ply 1	DRB - 71 FaNC Job Reference (optional)	163855480
-----------------	--------------	----------------------	----------	----------	---	-----------

Carter Components (Sanford, NC), Sanford, NC - 27332,

Run: 8.63 S Nov 1 2023 Print: 8.630 S Nov 1 2023 MiTek Industries, Inc. Mon Feb 26 11:35:19
ID:QBvI4TBXiDjLd3AwHhr8j?zhIFI-RfC?PsB70Hq3NSgPqnL8w3ulTXbGKWrCdoi7J4zJC?F

Page: 1

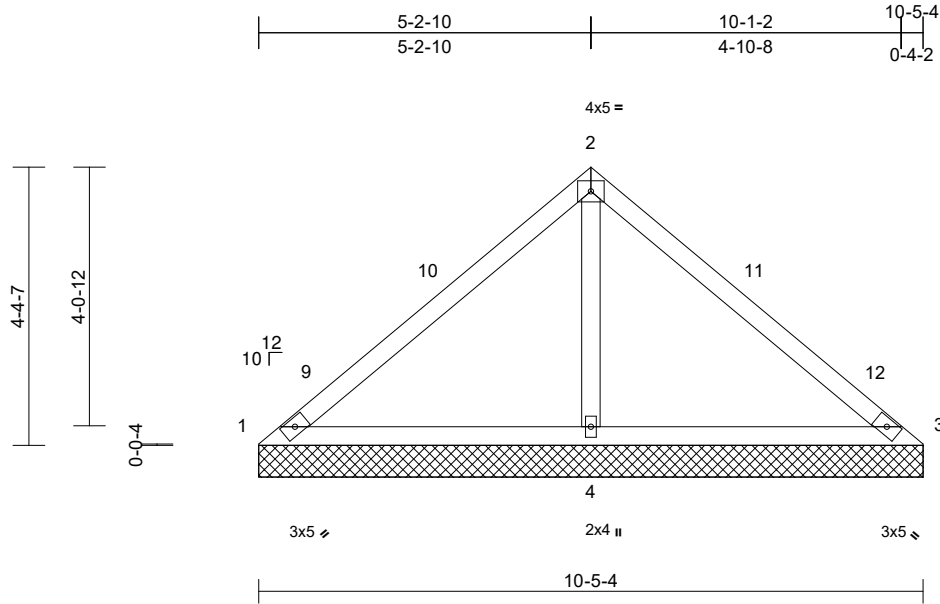

Scale = 1:36.2

Loading	(psf)	Spacing	2-0-0	CSI	DEFL	in	(loc)	l/defl	L/d	PLATES	GRIP	
TCLL (roof)	20.0	Plate Grip DOL	1.15	TC	0.54	Vert(LL)	n/a	-	n/a	999	MT20	244/190
Snow (Pf)	20.0	Lumber DOL	1.15	BC	0.48	Vert(TL)	n/a	-	n/a	999		
TCDL	10.0	Rep Stress Incr	YES	WB	0.23	Horiz(TL)	0.01	4	n/a	n/a		
BCLL	0.0*	Code	IRC2018/TPI2014	Matrix-MSH								
BCDL	10.0											
										Weight: 40 lb	FT = 20%	

LUMBER

TOP CHORD 2x4 SP No.2
BOT CHORD 2x4 SP No.2
OTHERS 2x4 SP No.3

BRACING

TOP CHORD Structural wood sheathing directly applied or 10-0-0 oc purlins.
BOT CHORD Rigid ceiling directly applied or 6-0-0 oc bracing.

REACTIONS

(size) 1=10-5-4, 3=10-5-4, 4=10-5-4
Max Horiz 1=98 (LC 11)
Max Uplift 1=-66 (LC 21), 3=-66 (LC 20), 4=-127 (LC 14)
Max Grav 1=82 (LC 20), 3=82 (LC 21), 4=862 (LC 20)

FORCES

(lb) - Maximum Compression/Maximum Tension

TOP CHORD 1-2=-133/426, 2-3=-133/426
BOT CHORD 1-4=-246/189, 3-4=-246/189
WEBS 2-4=-674/299

NOTES

- 1) Unbalanced roof live loads have been considered for this design.
- 2) Wind: ASCE 7-16; Vult=130mph (3-second gust) Vasd=103mph; TCDL=6.0psf; BCDL=6.0psf; h=25ft; Cat. II; Exp B; Enclosed; MWFRS (envelope) exterior zone and C-C Exterior(2E) 0-0-5 to 3-0-5, Exterior(2R) 3-0-5 to 7-5-9, Exterior(2E) 7-5-9 to 10-5-9 zone; cantilever left and right exposed; end vertical left and right exposed; C-C for members and forces & MWFRS for reactions shown; Lumber DOL=1.60 plate grip DOL=1.60
- 3) Truss designed for wind loads in the plane of the truss only. For studs exposed to wind (normal to the face), see Standard Industry Gable End Details as applicable, or consult qualified building designer as per ANSI/TPI 1.

- 4) TCLL: ASCE 7-16; Pr=20.0 psf (roof LL: Lum DOL=1.15 Plate DOL=1.15); Pf=20.0 psf (Lum DOL=1.15 Plate DOL=1.15); Is=1.0; Rough Cat B; Fully Exp.; Ce=0.9; Cs=1.00; Ct=1.10
- 5) Unbalanced snow loads have been considered for this design.
- 6) Gable requires continuous bottom chord bearing.
- 7) Gable studs spaced at 4-0-0 oc.
- 8) This truss has been designed for a 10.0 psf bottom chord live load nonconcurrent with any other live loads.
- 9) * This truss has been designed for a live load of 20.0psf on the bottom chord in all areas where a rectangle 3-06-00 tall by 2-00-00 wide will fit between the bottom chord and any other members.
- 10) Provide mechanical connection (by others) of truss to bearing plate capable of withstanding 66 lb uplift at joint 1, 66 lb uplift at joint 3 and 127 lb uplift at joint 4.
- 11) This truss is designed in accordance with the 2018 International Residential Code sections R502.11.1 and R802.10.2 and referenced standard ANSI/TPI 1.

LOAD CASE(S) Standard

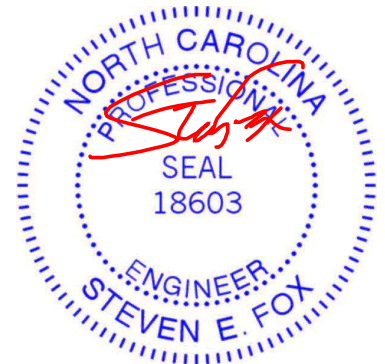

February 27, 2024

WARNING - Verify design parameters and READ NOTES ON THIS AND INCLUDED MITEK REFERENCE PAGE MII-7473 rev. 1/2/2023 BEFORE USE.

Design valid for use only with MiTek® connectors. This design is based only upon parameters shown, and is for an individual building component, not a truss system. Before use, the building designer must verify the applicability of design parameters and properly incorporate this design into the overall building design. Bracing indicated is to prevent buckling of individual truss web and/or chord members only. Additional temporary and permanent bracing is always required for stability and to prevent collapse with possible personal injury and property damage. For general guidance regarding the fabrication, storage, delivery, erection and bracing of trusses and truss systems, see **ANSI/TPI1 Quality Criteria and DSB-22** available from Truss Plate Institute (www.tpinst.org) and **BCSI Building Component Safety Information** available from the Structural Building Component Association (www.sbcacomponents.com)

ENGINEERING BY
TRENCO
A MiTek Affiliate

818 Soundside Road
Edenton, NC 27932

Job 24020110	Truss V13	Truss Type Valley	Qty 1	Ply 1	DRB - 71 FaNC Job Reference (optional)	I63855481
-----------------	--------------	----------------------	----------	----------	---	-----------

Carter Components (Sanford, NC), Sanford, NC - 27332,

Run: 8.63 S Nov 1 2023 Print: 8.630 S Nov 1 2023 MiTek Industries, Inc. Mon Feb 26 11:35:19
ID:XQfnF581e_Cv8Rs82rmCZ9zhIFM-RfC?PsB70Hq3NSgPqnL8w3uITXbGKWrCDoi7J4zJC7f

Page: 1

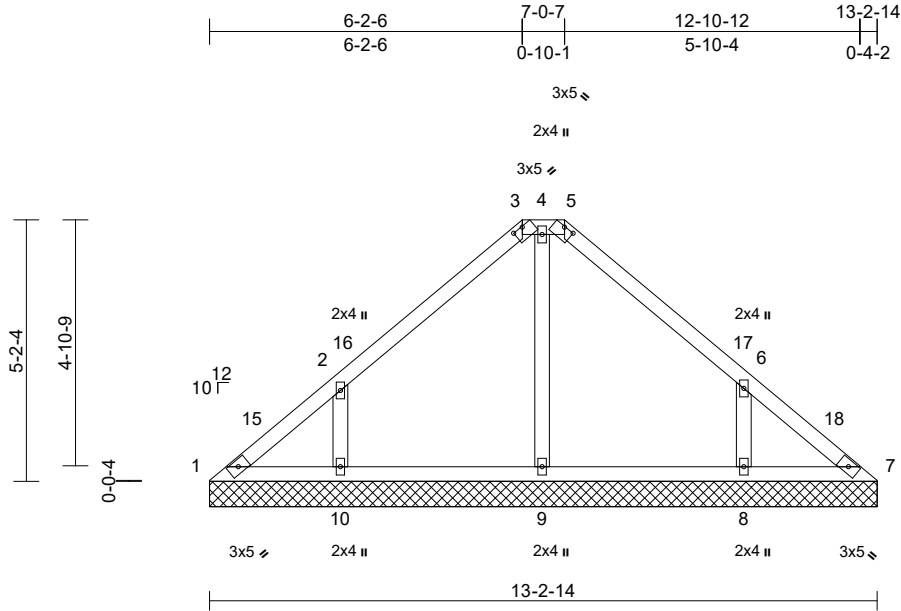

Scale = 1:45.7

Plate Offsets (X, Y): [3:0-2-8,0-0-3], [5:0-2-8,0-0-3]

Loading	(psf)	Spacing	2-0-0	CSI	DEFL	in	(loc)	l/defl	L/d	PLATES	GRIP	
TCLL (roof)	20.0	Plate Grip DOL	1.15	TC	0.26	Vert(LL)	n/a	-	n/a	999	MT20	244/190
Snow (Pf)	20.0	Lumber DOL	1.15	BC	0.12	Vert(TL)	n/a	-	n/a	999		
TCDL	10.0	Rep Stress Incr	YES	WB	0.12	Horiz(TL)	0.00	7	n/a	n/a		
BCLL	0.0*	Code	IRC2018/TPI2014	Matrix-MSH								
BCDL	10.0											
										Weight: 55 lb	FT = 20%	

LUMBER

TOP CHORD 2x4 SP No.2
BOT CHORD 2x4 SP No.2
OTHERS 2x4 SP No.3

BRACING

TOP CHORD Structural wood sheathing directly applied or 6-0-0 oc purlins, except 2-0-0 oc purlins (6-0-0 max.): 3-5.
BOT CHORD Rigid ceiling directly applied or 10-0-0 oc bracing.

REACTIONS

(size) 1=13-2-14, 7=13-2-14, 8=13-2-14, 9=13-2-14, 10=13-2-14
Max Horiz 1=-118 (LC 10)
Max Uplift 1=-29 (LC 10), 8=-137 (LC 15), 10=-140 (LC 14)
Max Grav 1=150 (LC 48), 7=143 (LC 38), 8=445 (LC 38), 9=318 (LC 38), 10=444 (LC 38)

FORCES

(lb) - Maximum Compression/Maximum Tension
TOP CHORD 1-2=-189/108, 2-3=-199/142, 3-4=-93/164, 4-5=-93/164, 5-6=-198/142, 6-7=-173/61
BOT CHORD 1-10=-36/138, 9-10=-35/93, 8-9=-35/93, 7-8=-35/125
WEBS 4-9=-240/15, 2-10=-357/257, 6-8=-357/253

NOTES

- Unbalanced roof live loads have been considered for this design.
- Wind: ASCE 7-16; Vult=130mph (3-second gust) Vasd=103mph; TCDL=6.0psf; BCDL=6.0psf; h=25ft; Cat. II; Exp B; Enclosed; MWFRS (envelope) exterior zone and C-C Corner(3E) 0-0-5 to 3-0-5, Corner(3R) 3-0-5 to 10-3-2, Corner(3E) 10-3-2 to 13-3-2 zone; cantilever left and right exposed; end vertical left and right exposed; C-C for members and forces & MWFRS for reactions shown; Lumber DOL=1.60 plate grip DOL=1.60

- Truss designed for wind loads in the plane of the truss only. For studs exposed to wind (normal to the face), see Standard Industry Gable End Details as applicable, or consult qualified building designer as per ANSI/TPI 1.
- TCLL: ASCE 7-16; Pr=20.0 psf (roof LL: Lum DOL=1.15 Plate DOL=1.15); Pf=20.0 psf (Lum DOL=1.15 Plate DOL=1.15); Is=1.0; Rough Cat B; Fully Exp.; Ce=0.9; Cs=1.00; Ct=1.10
- Unbalanced snow loads have been considered for this design.
- Provide adequate drainage to prevent water ponding.
- Gable requires continuous bottom chord bearing.
- Gable studs spaced at 4-0-0 oc.
- This truss has been designed for a 10.0 psf bottom chord live load nonconcurrent with any other live loads.
- * This truss has been designed for a live load of 20.0psf on the bottom chord in all areas where a rectangle 3-06-00 tall by 2-00-00 wide will fit between the bottom chord and any other members.
- Provide mechanical connection (by others) of truss to bearing plate capable of withstanding 29 lb uplift at joint 1, 140 lb uplift at joint 10 and 137 lb uplift at joint 8.
- This truss is designed in accordance with the 2018 International Residential Code sections R502.11.1 and R802.10.2 and referenced standard ANSI/TPI 1.
- Graphical purlin representation does not depict the size or the orientation of the purlin along the top and/or bottom chord.

LOAD CASE(S) Standard

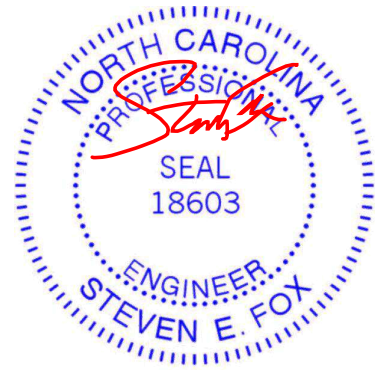

February 27, 2024

WARNING - Verify design parameters and READ NOTES ON THIS AND INCLUDED MITEK REFERENCE PAGE MII-7473 rev. 1/2/2023 BEFORE USE.

Design valid for use only with MiTek® connectors. This design is based only upon parameters shown, and is for an individual building component, not a truss system. Before use, the building designer must verify the applicability of design parameters and properly incorporate this design into the overall building design. Bracing indicated is to prevent buckling of individual truss web and/or chord members only. Additional temporary and permanent bracing is always required for stability and to prevent collapse with possible personal injury and property damage. For general guidance regarding the fabrication, storage, delivery, erection and bracing of trusses and truss systems, see **ANSI/TPI1 Quality Criteria and DSB-22** available from Truss Plate Institute (www.tpinst.org) and **BCSI Building Component Safety Information** available from the Structural Building Component Association (www.sbcacomponents.com)



818 Soundside Road
Edenton, NC 27932

Job 24020110	Truss V16	Truss Type Valley	Qty 1	Ply 1	DRB - 71 FaNC Job Reference (optional)	163855482
-----------------	--------------	----------------------	----------	----------	---	-----------

Carter Components (Sanford, NC), Sanford, NC - 27332,

Run: 8.63 S Nov 1 2023 Print: 8.630 S Nov 1 2023 MiTek Industries, Inc. Mon Feb 26 11:35:20
ID:EG9s4GRel9v8BXQ?efjcCwzhIGG-RfC?PsB70Hq3NSgPqnL8w3uITXbGKWrCDoi7J4zJC?F

Page: 1

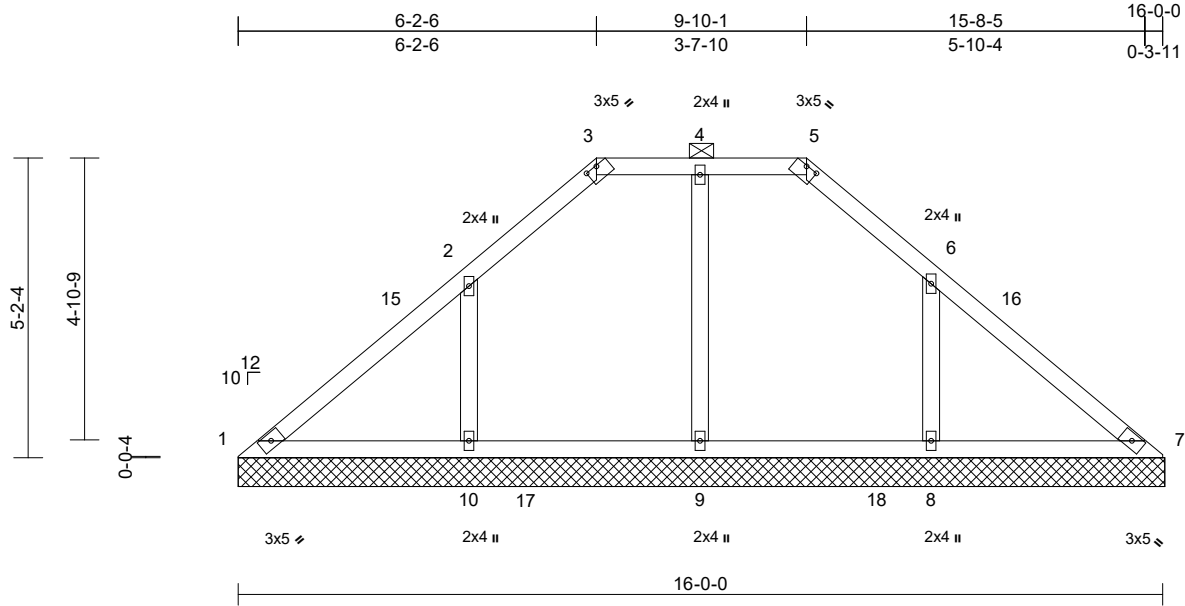

Scale = 1:39.9

Plate Offsets (X, Y): [3:0-2-8,0-0-3], [5:0-2-8,0-0-3]

Loading	(psf)	Spacing	2-0-0	CSI	DEFL	in	(loc)	l/defl	L/d	PLATES	GRIP	
TCLL (roof)	20.0	Plate Grip DOL	1.15	TC	0.28	Vert(LL)	n/a	-	n/a	999	MT20	244/190
Snow (Pf)	20.0	Lumber DOL	1.15	BC	0.28	Vert(TL)	n/a	-	n/a	999		
TCDL	10.0	Rep Stress Incr	YES	WB	0.13	Horiz(TL)	0.01	7	n/a	n/a		
BCLL	0.0*	Code	IRC2018/TPI2014	Matrix-MSH								
BCDL	10.0											
										Weight: 67 lb	FT = 20%	

LUMBER

TOP CHORD 2x4 SP No.2
BOT CHORD 2x4 SP No.2
OTHERS 2x4 SP No.3

BRACING

TOP CHORD Structural wood sheathing directly applied or 6'-0" oc purlins, except 2'-0" oc purlins (6'-0" max.): 3-5.
BOT CHORD Rigid ceiling directly applied or 6'-0" oc bracing.

REACTIONS

(size) 1=16-0-7, 7=16-0-7, 8=16-0-7, 9=16-0-7, 10=16-0-7
Max Horiz 1=-118 (LC 10)
Max Uplift 8=-133 (LC 15), 9=-5 (LC 11), 10=-139 (LC 14)
Max Grav 1=210 (LC 38), 7=213 (LC 38), 8=574 (LC 48), 9=405 (LC 43), 10=579 (LC 46)

FORCES

(lb) - Maximum Compression/Maximum Tension
TOP CHORD 1-2=-250/143, 2-3=-213/76, 3-4=-82/78, 4-5=-82/78, 5-6=-212/77, 6-7=-253/131
BOT CHORD 1-10=-69/217, 9-10=-69/157, 8-9=-69/157, 7-8=-69/194
WEBS 4-9=-258/62, 2-10=-369/213, 6-8=-369/212

NOTES

- Unbalanced roof live loads have been considered for this design.
- Wind: ASCE 7-16; Vult=130mph (3-second gust) Vasd=103mph; TCDL=6.0psf; BCDL=6.0psf; h=25ft; Cat. II; Exp B; Enclosed; MWFRS (envelope) exterior zone and C-C Corner(3E) 0-0-5 to 3-0-5, Corner(3R) 3-0-5 to 13-0-12, Corner(3E) 13-0-12 to 16-0-12 zone; cantilever left and right exposed ; end vertical left and right exposed;C-C for members and forces & MWFRS for reactions shown; Lumber DOL=1.60 plate grip DOL=1.60

- Truss designed for wind loads in the plane of the truss only. For studs exposed to wind (normal to the face), see Standard Industry Gable End Details as applicable, or consult qualified building designer as per ANSI/TPI 1.
- TCLL: ASCE 7-16; Pr=20.0 psf (roof LL: Lum DOL=1.15 Plate DOL=1.15); Pf=20.0 psf (Lum DOL=1.15 Plate DOL=1.15); Is=1.0; Rough Cat B; Fully Exp.; Ce=0.9; Cs=1.00; Ct=1.10
- Unbalanced snow loads have been considered for this design.
- Provide adequate drainage to prevent water ponding.
- Gable requires continuous bottom chord bearing.
- Gable studs spaced at 4'-0" oc.
- This truss has been designed for a 10.0 psf bottom chord live load nonconcurrent with any other live loads.
- * This truss has been designed for a live load of 20.0psf on the bottom chord in all areas where a rectangle 3'-06"-00 tall by 2'-00"-00 wide will fit between the bottom chord and any other members, with BCDL = 10.0psf.
- Provide mechanical connection (by others) of truss to bearing plate capable of withstanding 5 lb uplift at joint 9, 139 lb uplift at joint 10 and 133 lb uplift at joint 8.
- Beveled plate or shim required to provide full bearing surface with truss chord at joint(s) 7.
- This truss is designed in accordance with the 2018 International Residential Code sections R502.11.1 and R802.10.2 and referenced standard ANSI/TPI 1.
- Graphical purlin representation does not depict the size or the orientation of the purlin along the top and/or bottom chord.

LOAD CASE(S) Standard

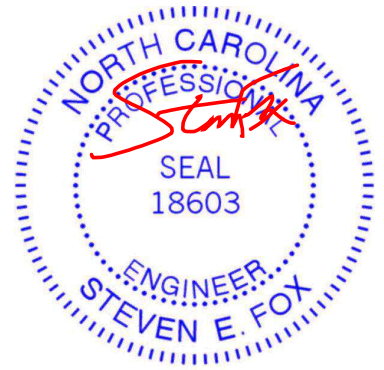

February 27, 2024

WARNING - Verify design parameters and READ NOTES ON THIS AND INCLUDED MITEK REFERENCE PAGE MII-7473 rev. 1/2/2023 BEFORE USE.

Design valid for use only with MiTek® connectors. This design is based only upon parameters shown, and is for an individual building component, not a truss system. Before use, the building designer must verify the applicability of design parameters and properly incorporate this design into the overall building design. Bracing indicated is to prevent buckling of individual truss web and/or chord members only. Additional temporary and permanent bracing is always required for stability and to prevent collapse with possible personal injury and property damage. For general guidance regarding the fabrication, storage, delivery, erection and bracing of trusses and truss systems, see **ANSI/TPI1 Quality Criteria and DSB-22** available from Truss Plate Institute (www.tpinst.org) and **BCSI Building Component Safety Information** available from the Structural Building Component Association (www.sbcacomponents.com)



818 Soundside Road
Edenton, NC 27932

Job 24020110	Truss V18	Truss Type Valley	Qty 1	Ply 1	DRB - 71 FaNC Job Reference (optional)	163855483
-----------------	--------------	----------------------	----------	----------	---	-----------

Carter Components (Sanford, NC), Sanford, NC - 27332,

Run: 8.63 S Nov 1 2023 Print: 8.630 S Nov 1 2023 MiTek Industries, Inc. Mon Feb 26 11:35:20
ID:WLY4zrJNf5eZ_?f43ZYGopzhIGQ-RfC?PsB70Hq3NSgPqnL8w3uITxBGKWrCDoi7J4zJC7f

Page: 1

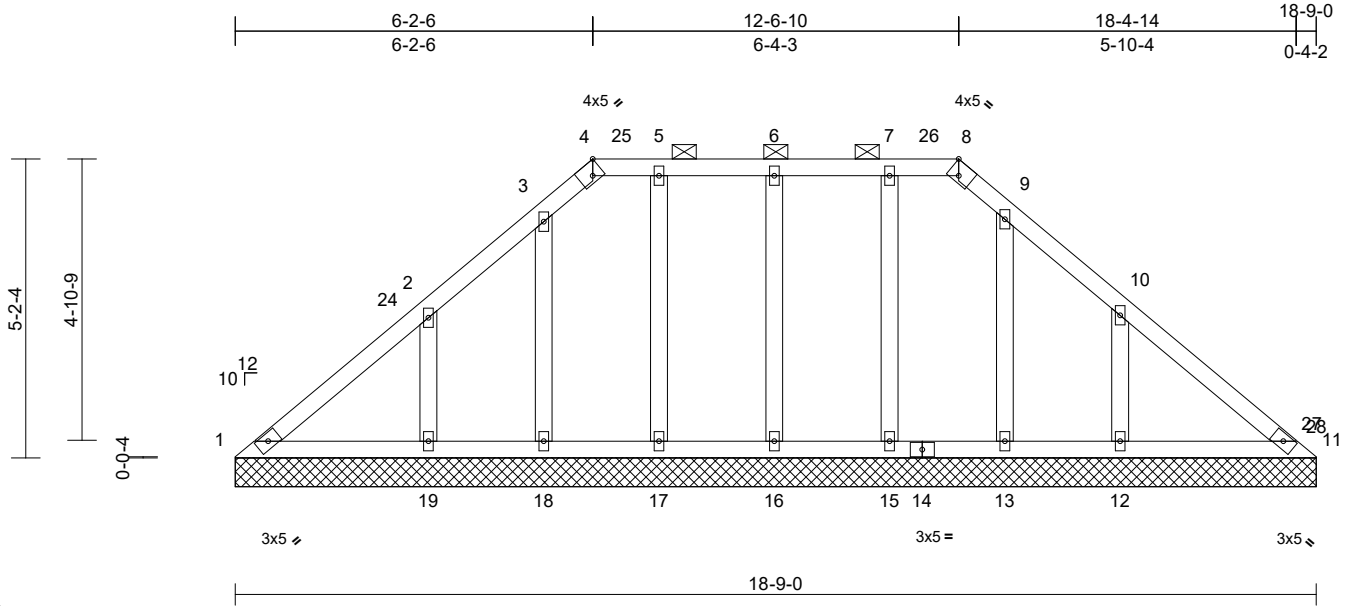

Scale = 1:40

Plate Offsets (X, Y): [4:0-2-4,Edge], [8:Edge,0-2-11]

Loading	(psf)	Spacing	1-11-4	CSI	DEFL	in	(loc)	l/defl	L/d	PLATES	GRIP	
TCLL (roof)	20.0	Plate Grip DOL	1.15	TC	0.17	Vert(LL)	n/a	-	n/a	999	MT20	244/190
Snow (Pf)	20.0	Lumber DOL	1.15	BC	0.17	Vert(TL)	n/a	-	n/a	999		
TCDL	10.0	Rep Stress Incr	YES	WB	0.09	Horiz(TL)	0.00	11	n/a	n/a		
BCLL	0.0*	Code	IRC2018/TPI2014	Matrix-MSH								
BCDL	10.0											
											Weight: 99 lb	FT = 20%

LUMBER

TOP CHORD 2x4 SP No.2
BOT CHORD 2x4 SP No.2
OTHERS 2x4 SP No.3

BRACING

TOP CHORD Structural wood sheathing directly applied or 6-0-0 oc purlins, except 2-0-0 oc purlins (6-0-0 max.): 4-8.
BOT CHORD Rigid ceiling directly applied or 6-0-0 oc bracing.

REACTIONS

(size) 1=18-9-0, 11=18-9-0, 12=18-9-0, 13=18-9-0, 15=18-9-0, 16=18-9-0, 17=18-9-0, 18=18-9-0, 19=18-9-0
Max Horiz 1=114 (LC 11)
Max Uplift 1=-6 (LC 10), 12=-113 (LC 15), 13=-16 (LC 15), 15=-11 (LC 11), 16=-35 (LC 10), 17=-18 (LC 11), 18=-27 (LC 14), 19=-114 (LC 14)
Max Grav 1=136 (LC 40), 11=107 (LC 42), 12=381 (LC 38), 13=164 (LC 38), 15=228 (LC 37), 16=224 (LC 37), 17=226 (LC 37), 18=167 (LC 38), 19=379 (LC 38)

FORCES

(lb) - Maximum Compression/Maximum Tension
TOP CHORD 1-2=-161/171, 2-3=-51/101, 3-4=-36/74, 4-5=-25/75, 5-6=-25/75, 6-7=-25/75, 7-8=-25/75, 8-9=-37/74, 9-10=-47/83, 10-11=-132/146
BOT CHORD 1-19=-68/135, 18-19=-68/127, 17-18=-68/127, 16-17=-68/127, 15-16=-68/127, 13-15=-68/127, 12-13=-68/127, 11-12=-68/127
WEBS 6-16=-188/66, 5-17=-183/42, 3-18=-158/54, 2-19=-266/160, 7-15=-184/37, 9-13=-156/43, 10-12=-269/165

NOTES

- Unbalanced roof live loads have been considered for this design.
- Wind: ASCE 7-16; Vult=130mph (3-second gust) Vasd=103mph; TC DL=6.0psf; BCDL=6.0psf; h=25ft; Cat. II; Exp B; Enclosed; MWFRS (envelope) exterior zone and C-C Corner(3E) 0-0-5 to 3-0-5, Corner(3R) 3-0-5 to 15-4-8, Corner(3E) 15-4-8 to 18-4-12 zone; cantilever left and right exposed ; end vertical left and right exposed;C-C for members and forces & MWFRS for reactions shown; Lumber DOL=1.60 plate grip DOL=1.60
- Truss designed for wind loads in the plane of the truss only. For studs exposed to wind (normal to the face), see Standard Industry Gable End Details as applicable, or consult qualified building designer as per ANSI/TPI 1.
- TCLL: ASCE 7-16; Pr=20.0 psf (roof LL: Lum DOL=1.15 Plate DOL=1.15); Pf=20.0 psf (Lum DOL=1.15 Plate DOL=1.15); Is=1.0; Rough Cat B; Fully Exp.; Ce=0.9; Cs=1.00; Ct=1.10
- Unbalanced snow loads have been considered for this design.
- Provide adequate drainage to prevent water ponding.
- All plates are 2x4 MT20 unless otherwise indicated.
- Gable requires continuous bottom chord bearing.
- Gable studs spaced at 2-0-0 oc.
- This truss has been designed for a 10.0 psf bottom chord live load nonconcurrent with any other live loads.
- * This truss has been designed for a live load of 20.0psf on the bottom chord in all areas where a rectangle 3-06-00 tall by 2-00-00 wide will fit between the bottom chord and any other members.
- Provide mechanical connection (by others) of truss to bearing plate capable of withstanding 6 lb uplift at joint 1, 35 lb uplift at joint 16, 18 lb uplift at joint 17, 27 lb uplift at joint 18, 114 lb uplift at joint 19, 11 lb uplift at joint 15, 16 lb uplift at joint 13 and 113 lb uplift at joint 12.

- This truss is designed in accordance with the 2018 International Residential Code sections R502.11.1 and R802.10.2 and referenced standard ANSI/TPI 1.
 - Graphical purlin representation does not depict the size or the orientation of the purlin along the top and/or bottom chord.
- LOAD CASE(S)** Standard

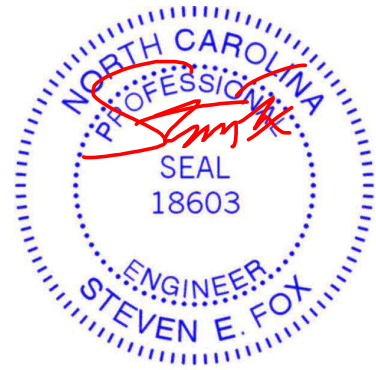

February 27, 2024

WARNING - Verify design parameters and READ NOTES ON THIS AND INCLUDED MITEK REFERENCE PAGE MII-7473 rev. 1/2/2023 BEFORE USE.

Design valid for use only with MiTek® connectors. This design is based only upon parameters shown, and is for an individual building component, not a truss system. Before use, the building designer must verify the applicability of design parameters and properly incorporate this design into the overall building design. Bracing indicated is to prevent buckling of individual truss web and/or chord members only. Additional temporary and permanent bracing is always required for stability and to prevent collapse with possible personal injury and property damage. For general guidance regarding the fabrication, storage, delivery, erection and bracing of trusses and truss systems, see **ANSI/TPI1 Quality Criteria and DSB-22** available from Truss Plate Institute (www.tpinst.org) and **BCSI Building Component Safety Information** available from the Structural Building Component Association (www.sbccomponents.com)



818 Soundside Road
Edenton, NC 27932

Symbols

PLATE LOCATION AND ORIENTATION

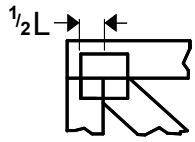

Center plate on joint unless x, y offsets are indicated. Dimensions are in ft-in-sixteenths. Apply plates to both sides of truss and fully embed teeth.

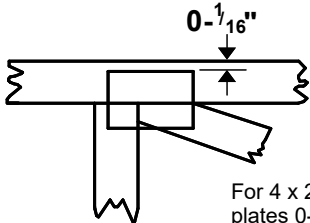

For 4 x 2 orientation, locate plates 0- 1/16" from outside edge of truss.



This symbol indicates the required direction of slots in connector plates.

* Plate location details available in MiTek software or upon request.

PLATE SIZE

4 x 4

The first dimension is the plate width measured perpendicular to slots. Second dimension is the length parallel to slots.

LATERAL BRACING LOCATION

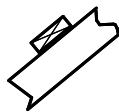

Indicated by symbol shown and/or by text in the bracing section of the output. Use T or I bracing if indicated.

BEARING

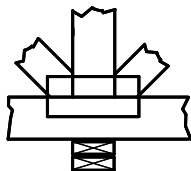

Indicates location where bearings (supports) occur. Icons vary but reaction section indicates joint number/letter where bearings occur. Min size shown is for crushing only.

Industry Standards:

- ANSI/TPI1: National Design Specification for Metal Plate Connected Wood Truss Construction.
- DSB-22: Design Standard for Bracing.
- BCSI: Building Component Safety Information, Guide to Good Practice for Handling, Installing, Restraining & Bracing of Metal Plate Connected Wood Trusses.

Numbering System

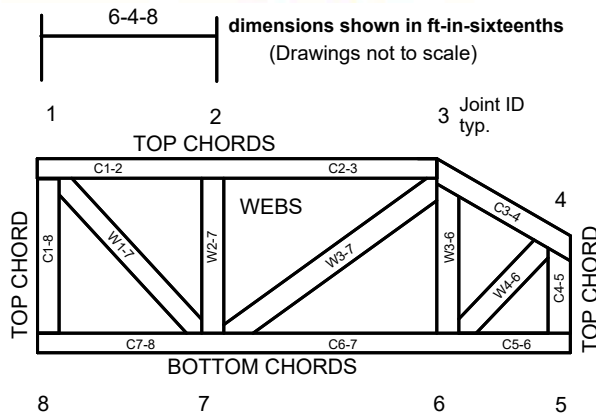

JOINTS ARE GENERALLY NUMBERED/LETTERED CLOCKWISE AROUND THE TRUSS STARTING AT THE JOINT FARTHEST TO THE LEFT.

CHORDS AND WEBS ARE IDENTIFIED BY END JOINT NUMBERS/LETTERS.

Product Code Approvals

ICC-ES Reports:

- ESR-1988, ESR-2362, ESR-2685, ESR-3282
- ESR-4722, ESL-1388

Design General Notes

Trusses are designed for wind loads in the plane of the truss unless otherwise shown.

Lumber design values are in accordance with ANSI/TPI 1 section 6.3 These truss designs rely on lumber values established by others.

© 2023 MiTek® All Rights Reserved



MiTek Engineering Reference Sheet: MII-7473 rev. 1/2/2023

General Safety Notes

Failure to Follow Could Cause Property Damage or Personal Injury

1. Additional stability bracing for truss system, e.g. diagonal or X-bracing, is always required. See BCSI.
2. Truss bracing must be designed by an engineer. For wide truss spacing, individual lateral braces themselves may require bracing, or alternative Tor I bracing should be considered.
3. Never exceed the design loading shown and never stack materials on inadequately braced trusses.
4. Provide copies of this truss design to the building designer, erection supervisor, property owner and all other interested parties.
5. Cut members to bear tightly against each other.
6. Place plates on each face of truss at each joint and embed fully. Knots and wane at joint locations are regulated by ANSI/TPI 1.
7. Design assumes trusses will be suitably protected from the environment in accord with ANSI/TPI 1.
8. Unless otherwise noted, moisture content of lumber shall not exceed 19% at time of fabrication.
9. Unless expressly noted, this design is not applicable for use with fire retardant, preservative treated, or green lumber.
10. Camber is a non-structural consideration and is the responsibility of truss fabricator. General practice is to camber for dead load deflection.
11. Plate type, size, orientation and location dimensions indicated are minimum plating requirements.
12. Lumber used shall be of the species and size, and in all respects, equal to or better than that specified.
13. Top chords must be sheathed or purlins provided at spacing indicated on design.
14. Bottom chords require lateral bracing at 10 ft. spacing, or less, if no ceiling is installed, unless otherwise noted.
15. Connections not shown are the responsibility of others.
16. Do not cut or alter truss member or plate without prior approval of an engineer.
17. Install and load vertically unless indicated otherwise.
18. Use of green or treated lumber may pose unacceptable environmental, health or performance risks. Consult with project engineer before use.
19. Review all portions of this design (front, back, words and pictures) before use. Reviewing pictures alone is not sufficient.
20. Design assumes manufacture in accordance with ANSI/TPI 1 Quality Criteria.
21. The design does not take into account any dynamic or other loads other than those expressly stated.