

Trenco
818 Soundside Rd
Edenton, NC 27932

Re: 24030153-01
142 Serenity-Roof-B329 B LH CP

The truss drawing(s) referenced below have been prepared by Truss Engineering Co. under my direct supervision based on the parameters provided by Carter Components (Sanford, NC)).

Pages or sheets covered by this seal: I64576253 thru I64576296

My license renewal date for the state of North Carolina is December 31, 2024.

North Carolina COA: C-0844



April 1, 2024

Tony Miller

IMPORTANT NOTE: The seal on these truss component designs is a certification that the engineer named is licensed in the jurisdiction(s) identified and that the designs comply with ANSI/TPI 1. These designs are based upon parameters shown (e.g., loads, supports, dimensions, shapes and design codes), which were given to MiTek or TRENCO. Any project specific information included is for MiTek's or TRENCO's customers file reference purpose only, and was not taken into account in the preparation of these designs. MiTek or TRENCO has not independently verified the applicability of the design parameters or the designs for any particular building. Before use, the building designer should verify applicability of design parameters and properly incorporate these designs into the overall building design per ANSI/TPI 1, Chapter 2.

Job 24030153-01	Truss GGE	Truss Type Common Supported Gable	Qty 1	Ply 1	142 Serenity-Roof-B329 B LH CP Job Reference (optional)	164576253
--------------------	--------------	--------------------------------------	----------	----------	--	-----------

Carter Components (Sanford, NC), Sanford, NC - 27332,

Run: 9.03 S 8.73 Mar 21 2024 Print: 8.730 S Mar 21 2024 MiTek Industries, Inc. Fri Mar 29 10:41:42
ID:H5y9cKKYeyPOV7lubbBRXyzMCst-RIC?PsB70Hq3NSgPqnL8w3uITXbGKWRCDoi7J4zJC?f

Page: 1

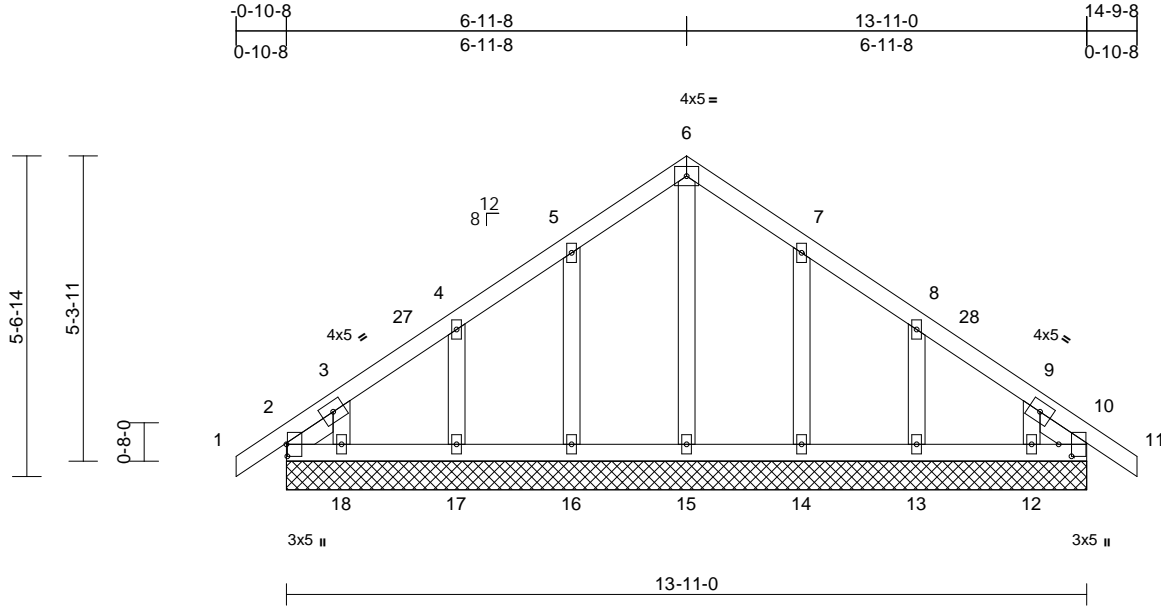

Scale = 1:40.1

Plate Offsets (X, Y): [2:0-2-8,0-0-3], [10:0-2-8,0-2-11]

Loading	(psf)	Spacing	2-0-0	CSI	DEFL	in	(loc)	l/defl	L/d	PLATES	GRIP	
TCLL (roof)	20.0	Plate Grip DOL	1.15	TC	0.08	Vert(LL)	n/a	-	n/a	999	MT20	244/190
Snow (Pf)	20.0	Lumber DOL	1.15	BC	0.03	Vert(CT)	n/a	-	n/a	999		
TCDL	10.0	Rep Stress Incr	YES	WB	0.07	Horz(CT)	0.00	10	n/a	n/a		
BCLL	0.0*	Code	IRC2018/TPI2014	Matrix-MSH								
BCDL	10.0										Weight: 78 lb	FT = 20%

LUMBER
TOP CHORD 2x4 SP No.2
BOT CHORD 2x4 SP No.2
OTHERS 2x4 SP No.3
SLIDER Left 2x4 SP No.3 -- 0-11-14, Right 2x4 SP No.3 -- 0-11-14

NOTES
1) Unbalanced roof live loads have been considered for this design.
2) Wind: ASCE 7-16; Vult=130mph (3-second gust) Vasd=103mph; TCCL=6.0psf; BCCL=6.0psf; h=25ft; Cat. II; Exp B; Enclosed; MWFRS (envelope) exterior zone and C-C Corner(3E) -0-10-8 to 2-1-8, Exterior(2N) 2-1-8 to 3-11-8, Corner(3R) 3-11-8 to 9-11-8, Exterior(2N) 9-11-8 to 11-9-8, Corner(3E) 11-9-8 to 14-9-8 zone; cantilever left and right exposed; end vertical left and right exposed; C-C for members and forces & MWFRS for reactions shown; Lumber DOL=1.60 plate grip DOL=1.60
3) Truss designed for wind loads in the plane of the truss only. For studs exposed to wind (normal to the face), see Standard Industry Gable End Details as applicable, or consult qualified building designer as per ANSI/TPI 1.
4) TCLL: ASCE 7-16; Pr=20.0 psf (roof LL: Lum DOL=1.15 Plate DOL=1.15); Pf=20.0 psf (Lum DOL=1.15 Plate DOL=1.15); Is=1.0; Rough Cat B; Fully Exp.; Ce=0.9; Cs=1.00; Ct=1.10
5) Unbalanced snow loads have been considered for this design.
6) This truss has been designed for greater of min roof live load of 12.0 psf or 1.00 times flat roof load of 20.0 psf on overhangs non-concurrent with other live loads.
7) All plates are 2x4 MT20 unless otherwise indicated.
8) Gable requires continuous bottom chord bearing.
9) Gable studs spaced at 2-0-0 oc.
10) This truss has been designed for a 10.0 psf bottom chord live load nonconcurrent with any other live loads.

11) * This truss has been designed for a live load of 20.0psf on the bottom chord in all areas where a rectangle 3-06-00 tall by 2-00-00 wide will fit between the bottom chord and any other members.
12) N/A

BRACING
TOP CHORD Structural wood sheathing directly applied or 6-0-0 oc purlins.
BOT CHORD Rigid ceiling directly applied or 10-0-0 oc bracing.

REACTIONS (size)
2=13-11-0, 10=13-11-0, 12=13-11-0, 13=13-11-0, 14=13-11-0, 15=13-11-0, 16=13-11-0, 17=13-11-0, 18=13-11-0, 19=13-11-0, 23=13-11-0
Max Horiz 2=-123 (LC 12), 19=-123 (LC 12)
Max Uplift 2=-47 (LC 10), 10=-13 (LC 11), 12=-68 (LC 15), 13=-60 (LC 15), 14=-60 (LC 15), 16=-61 (LC 14), 17=-59 (LC 14), 18=-77 (LC 14), 19=-47 (LC 10), 23=-13 (LC 11)
Max Grav 2=129 (LC 26), 10=112 (LC 22), 12=126 (LC 26), 13=227 (LC 22), 14=259 (LC 22), 15=146 (LC 33), 16=259 (LC 21), 17=227 (LC 21), 18=136 (LC 25), 19=129 (LC 26), 23=112 (LC 22)

FORCES (lb) - Maximum Compression/Maximum Tension
TOP CHORD 1-2=0/29, 2-3=-71/76, 3-4=-93/76, 4-5=-82/79, 5-6=-91/152, 6-7=-91/152, 7-8=-75/79, 8-9=-61/34, 9-10=-70/58, 10-11=0/29

13) This truss is designed in accordance with the 2018 International Residential Code sections R502.11.1 and R802.10.2 and referenced standard ANSI/TPI 1.
LOAD CASE(S) Standard

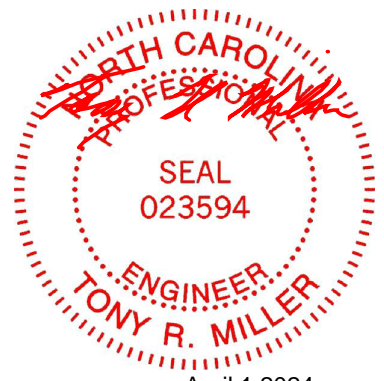

April 1, 2024

WARNING - Verify design parameters and READ NOTES ON THIS AND INCLUDED MITEK REFERENCE PAGE MII-7473 rev. 1/2/2023 BEFORE USE.
Design valid for use only with MiTek® connectors. This design is based only upon parameters shown, and is for an individual building component, not a truss system. Before use, the building designer must verify the applicability of design parameters and properly incorporate this design into the overall building design. Bracing indicated is to prevent buckling of individual truss web and/or chord members only. Additional temporary and permanent bracing is always required for stability and to prevent collapse with possible personal injury and property damage. For general guidance regarding the fabrication, storage, delivery, erection and bracing of trusses and truss systems, see **ANSI/TPI Quality Criteria and DSB-22** available from Truss Plate Institute (www.tpinst.org) and **BCSI Building Component Safety Information** available from the Structural Building Component Association (www.sbcacomponents.com)

ENGINEERING BY
TRENCO
A MiTek Affiliate
818 Soundside Road
Edenton, NC 27932

Job 24030153-01	Truss BSE	Truss Type Common Structural Gable	Qty 1	Ply 1	142 Serenity-Roof-B329 B LH CP Job Reference (optional)	164576254
--------------------	--------------	---------------------------------------	----------	----------	--	-----------

Carter Components (Sanford, NC), Sanford, NC - 27332,

Run: 9.03 S 8.73 Mar 21 2024 Print: 8.730 S Mar 21 2024 MITek Industries, Inc. Fri Mar 29 10:41:40
ID:PsmVvbbMaAB85kbfL?kTKzMCsP-RfC?PsB70Hq3NSgPqnl8w3ulTXbGKwRCdoi7J4zJC?f

Page: 1

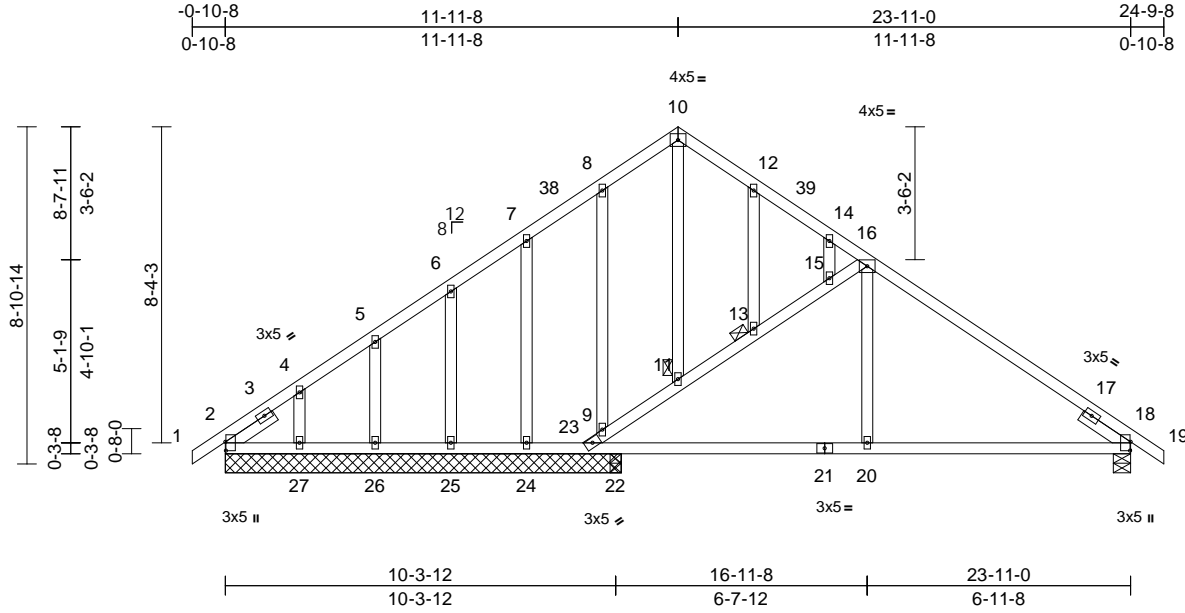

Scale = 1:60.9
Plate Offsets (X, Y): [2:0-2-13,0-0-3], [18:0-2-13,0-0-3]

Loading	(psf)	Spacing	2-0-0	CSI	DEFL	in	(loc)	l/defl	L/d	PLATES	GRIP	
TCLL (roof)	20.0	Plate Grip DOL	1.15	TC	0.49	Vert(LL)	0.07	20-36	>999	240	MT20	244/190
Snow (Pf)	20.0	Lumber DOL	1.15	BC	0.41	Vert(CT)	-0.10	20-36	>999	180		
TCDL	10.0	Rep Stress Incr	YES	WB	0.11	Horz(CT)	0.02	18	n/a	n/a		
BCLL	0.0*	Code	IRC2018/TPI2014	Matrix-MSH								
BCDL	10.0											
											Weight: 154 lb	FT = 20%

LUMBER
TOP CHORD 2x4 SP No.2
BOT CHORD 2x4 SP No.2
WEBS 2x4 SP No.3
OTHERS 2x4 SP No.3
SLIDER Left 2x4 SP No.3 -- 1-6-0, Right 2x4 SP No.3 -- 1-6-0

BRACING
TOP CHORD Structural wood sheathing directly applied or 6-0-0 oc purlins.
BOT CHORD Rigid ceiling directly applied or 10-0-0 oc bracing.
JOINTS 1 Brace at Jt(s): 11, 13

REACTIONS (size)
2=10-5-8, 18=0-5-8, 22=0-3-8, 24=10-5-8, 25=10-5-8, 26=10-5-8, 27=10-5-8, 28=10-5-8, 34=0-5-8
Max Horiz 2=-201 (LC 12), 28=-201 (LC 12)
Max Uplift 2=-27 (LC 10), 18=-80 (LC 15), 24=-123 (LC 14), 25=-42 (LC 14), 26=-51 (LC 14), 27=-112 (LC 14), 28=-27 (LC 10), 34=-80 (LC 15)
Max Grav 2=247 (LC 26), 18=669 (LC 1), 22=417 (LC 7), 24=277 (LC 1), 25=145 (LC 25), 26=175 (LC 1), 27=168 (LC 25), 28=247 (LC 26), 34=669 (LC 1)

FORCES (lb) - Maximum Compression/Maximum Tension
TOP CHORD 1-2=0/29, 2-4=-251/112, 4-5=-224/82, 5-6=-215/68, 6-7=-199/60, 7-8=-192/100, 8-10=-200/112, 10-12=-185/113, 12-14=-201/73, 14-16=-220/57, 16-18=-730/91, 18-19=0/29, 9-23=-449/647, 9-11=-580/172, 11-13=-596/200, 13-15=-551/171, 15-16=-542/168

NOTES
1) Unbalanced roof live loads have been considered for this design.
2) Wind: ASCE 7-16; Vult=130mph (3-second gust) Vasd=103mph; TCCL=6.0psf; BCDL=6.0psf; h=25ft; Cat. II; Exp B; Enclosed; MWFRS (envelope) exterior zone and C-C Exterior(2E) -0-10-8 to 1-11-8, Interior (1) 1-11-8 to 8-11-8, Exterior(2R) 8-11-8 to 14-11-8, Interior (1) 14-11-8 to 21-9-8, Exterior(2E) 21-9-8 to 24-9-8 zone; cantilever left and right exposed ; end vertical left and right exposed;C-C for members and forces & MWFRS for reactions shown; Lumber DOL=1.60 plate grip DOL=1.60
3) Truss designed for wind loads in the plane of the truss only. For studs exposed to wind (normal to the face), see Standard Industry Gable End Details as applicable, or consult qualified building designer as per ANSI/TPI 1.
4) TCLL: ASCE 7-16; Pr=20.0 psf (roof LL: Lum DOL=1.15 Plate DOL=1.15); Pf=20.0 psf (Lum DOL=1.15 Plate DOL=1.15); Is=1.0; Rough Cat B; Fully Exp.; Ce=0.9; Cs=1.00; Ct=1.10
5) Unbalanced snow loads have been considered for this design.
6) This truss has been designed for greater of min roof live load of 12.0 psf or 1.00 times flat roof load of 20.0 psf on overhangs non-concurrent with other live loads.
7) All plates are 2x4 MT20 unless otherwise indicated.
8) Gable studs spaced at 2-0-0 oc.
9) This truss has been designed for a 10.0 psf bottom chord live load nonconcurrent with any other live loads.

10) * This truss has been designed for a live load of 20.0psf on the bottom chord in all areas where a rectangle 3-06-00 tall by 2-00-00 wide will fit between the bottom chord and any other members.
11) One H2.5A Simpson Strong-Tie connectors recommended to connect truss to bearing walls due to UPLIFT at joint 18. This connection is for uplift only and does not consider lateral forces.
12) This truss is designed in accordance with the 2018 International Residential Code sections R502.11.1 and R802.10.2 and referenced standard ANSI/TPI 1.
13) Graphical purlin representation does not depict the size or the orientation of the purlin along the top and/or bottom chord.

LOAD CASE(S) Standard

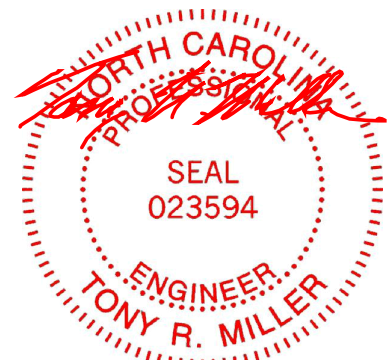

April 1, 2024

WARNING - Verify design parameters and READ NOTES ON THIS AND INCLUDED MITEK REFERENCE PAGE MII-7473 rev. 1/2/2023 BEFORE USE.

Design valid for use only with MITek® connectors. This design is based only upon parameters shown, and is for an individual building component, not a truss system. Before use, the building designer must verify the applicability of design parameters and properly incorporate this design into the overall building design. Bracing indicated is to prevent buckling of individual truss web and/or chord members only. Additional temporary and permanent bracing is always required for stability and to prevent collapse with possible personal injury and property damage. For general guidance regarding the fabrication, storage, delivery, erection and bracing of trusses and truss systems, see **ANSI/TP1 Quality Criteria and DSB-22** available from Truss Plate Institute (www.tpinst.org) and **BCSI Building Component Safety Information** available from the Structural Building Component Association (www.sbcacomponents.com)



818 Soundside Road
Edenton, NC 27932

Job 24030153-01	Truss B	Truss Type Common	Qty 7	Ply 1	142 Serenity-Roof-B329 B LH CP Job Reference (optional)	164576255
--------------------	------------	----------------------	----------	----------	--	-----------

Carter Components (Sanford, NC), Sanford, NC - 27332,

Run: 9.03 S 8.73 Mar 21 2024 Print: 8.730 S Mar 21 2024 MiTek Industries, Inc. Fri Mar 29 10:41:39
ID:EMM7m2s8ARjqRghTN8EGzMCQR-RfC?PsB70Hq3NSgPqnL8w3uITXbGKWrCDoi7J4zJC7f

Page: 1

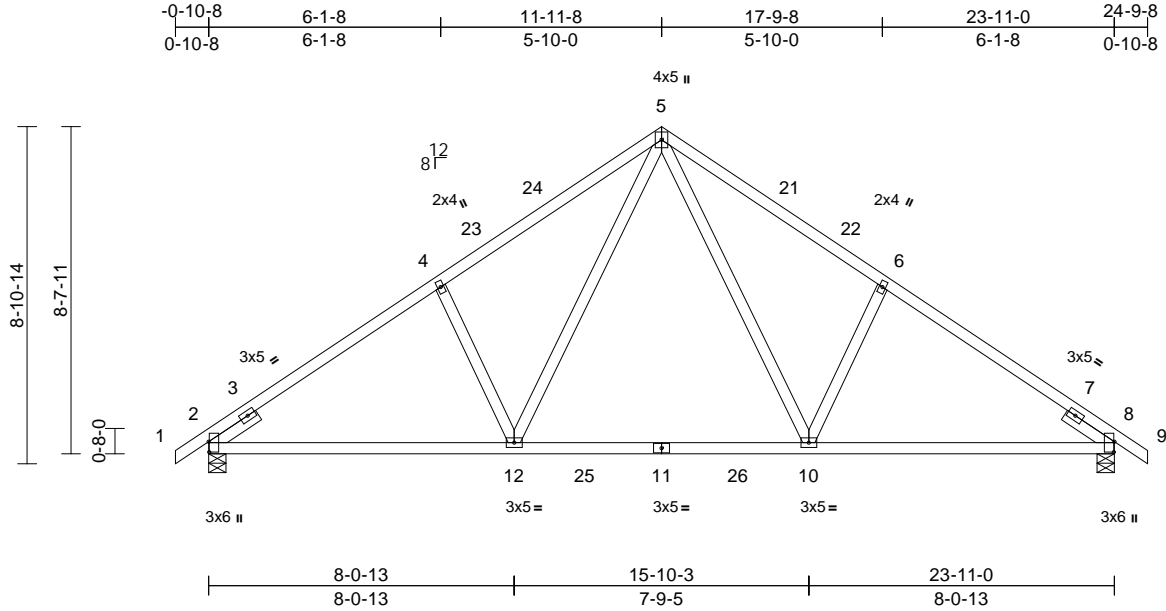

Scale = 1:60.8

Plate Offsets (X, Y): [2:0-3-5,0-0-3], [8:0-3-5,0-0-3]

Loading	(psf)	Spacing	2-0-0	CSI	DEFL	in (loc)	l/defl	L/d	PLATES	GRIP		
TCLL (roof)	20.0	Plate Grip DOL	1.15	TC	0.85	Vert(LL)	-0.16	10-12	>999	240	MT20	244/190
Snow (Pf)	20.0	Lumber DOL	1.15	BC	0.70	Vert(CT)	-0.23	10-12	>999	180		
TCDL	10.0	Rep Stress Incr	YES	WB	0.27	Horz(CT)	-0.03	2	n/a	n/a		
BCLL	0.0*	Code	IRC2018/TPI2014	Matrix-MSH								
BCDL	10.0											
										Weight: 126 lb	FT = 20%	

LUMBER

TOP CHORD 2x4 SP No.2
 BOT CHORD 2x4 SP No.2
 WEBS 2x4 SP No.3
 SLIDER Left 2x4 SP No.3 -- 1-6-0, Right 2x4 SP No.3 -- 1-6-0

BRACING

TOP CHORD Structural wood sheathing directly applied or 2-2-0 oc purlins.
 BOT CHORD Rigid ceiling directly applied or 10-0-0 oc bracing.

REACTIONS

(size) 2=0-5-8, 8=0-5-8
 Max Horiz 8=201 (LC 13)
 Max Uplift 2=-99 (LC 14), 8=-99 (LC 15)
 Max Grav 2=1136 (LC 25), 8=1136 (LC 26)

FORCES

(lb) - Maximum Compression/Maximum Tension
 TOP CHORD 5-6=-1566/217, 6-8=-1647/152, 8-9=0/29, 1-2=0/29, 2-4=-1647/152, 4-5=-1566/217
 BOT CHORD 2-12=-101/1296, 10-12=0/844, 8-10=-209/1296
 WEBS 5-12=-128/709, 4-12=-384/223, 5-10=-128/709, 6-10=-384/223

NOTES

- 1) Unbalanced roof live loads have been considered for this design.
- 2) Wind: ASCE 7-16; Vult=130mph (3-second gust) Vasd=103mph; TCDL=6.0psf; BCDL=6.0psf; h=25ft; Cat. II; Exp B; Enclosed; MWFRS (envelope) exterior zone and C-C Exterior(2E) -0-10-8 to 2-1-8, Interior (1) 2-1-8 to 8-11-8, Exterior(2R) 8-11-8 to 14-11-8, Interior (1) 14-11-8 to 21-9-8, Exterior(2E) 21-9-8 to 24-9-8 zone; cantilever left and right exposed ; end vertical left and right exposed;C-C for members and forces & MWFRS for reactions shown; Lumber DOL=1.60 plate grip DOL=1.60

- 3) TCLL: ASCE 7-16; Pr=20.0 psf (roof LL: Lum DOL=1.15 Plate DOL=1.15); Pf=20.0 psf (Lum DOL=1.15 Plate DOL=1.15); Is=1.0; Rough Cat B; Fully Exp.; Ce=0.9; Cs=1.00; Ct=1.10
- 4) Unbalanced snow loads have been considered for this design.
- 5) This truss has been designed for greater of min roof live load of 12.0 psf or 1.00 times flat roof load of 20.0 psf on overhangs non-concurrent with other live loads.
- 6) This truss has been designed for a 10.0 psf bottom chord live load nonconcurrent with any other live loads.
- 7) * This truss has been designed for a live load of 20.0psf on the bottom chord in all areas where a rectangle 3-06-00 tall by 2-00-00 wide will fit between the bottom chord and any other members, with BCDL = 10.0psf.
- 8) One H2.5A Simpson Strong-Tie connectors recommended to connect truss to bearing walls due to UPLIFT at jt(s) 2 and 8. This connection is for uplift only and does not consider lateral forces.
- 9) This truss is designed in accordance with the 2018 International Residential Code sections R502.11.1 and R802.10.2 and referenced standard ANSI/TPI 1.

LOAD CASE(S) Standard



April 1, 2024

WARNING - Verify design parameters and READ NOTES ON THIS AND INCLUDED MITEK REFERENCE PAGE MII-7473 rev. 1/2/2023 BEFORE USE.

Design valid for use only with MiTek® connectors. This design is based only upon parameters shown, and is for an individual building component, not a truss system. Before use, the building designer must verify the applicability of design parameters and properly incorporate this design into the overall building design. Bracing indicated is to prevent buckling of individual truss web and/or chord members only. Additional temporary and permanent bracing is always required for stability and to prevent collapse with possible personal injury and property damage. For general guidance regarding the fabrication, storage, delivery, erection and bracing of trusses and truss systems, see **ANSI/TPI1 Quality Criteria and DSB-22** available from Truss Plate Institute (www.tpinst.org) and **BCSI Building Component Safety Information** available from the Structural Building Component Association (www.sbcacomponents.com)



818 Soundside Road
 Edenton, NC 27932

Job 24030153-01	Truss DSE	Truss Type Common Supported Gable	Qty 1	Ply 1	142 Serenity-Roof-B329 B LH CP Job Reference (optional)	164576256
--------------------	--------------	--------------------------------------	----------	----------	--	-----------

Carter Components (Sanford, NC), Sanford, NC - 27332,

Run: 9.03 S 8.73 Mar 21 2024 Print: 8.730 S Mar 21 2024 MiTek Industries, Inc. Fri Mar 29 10:41:41
ID:scQGvP9BX7kqzHzzzTKiZMCKE-RfC?PsB70Hq3NSgPqL8w3uITXbGKwRCdoi7J4zJC?7

Page: 1

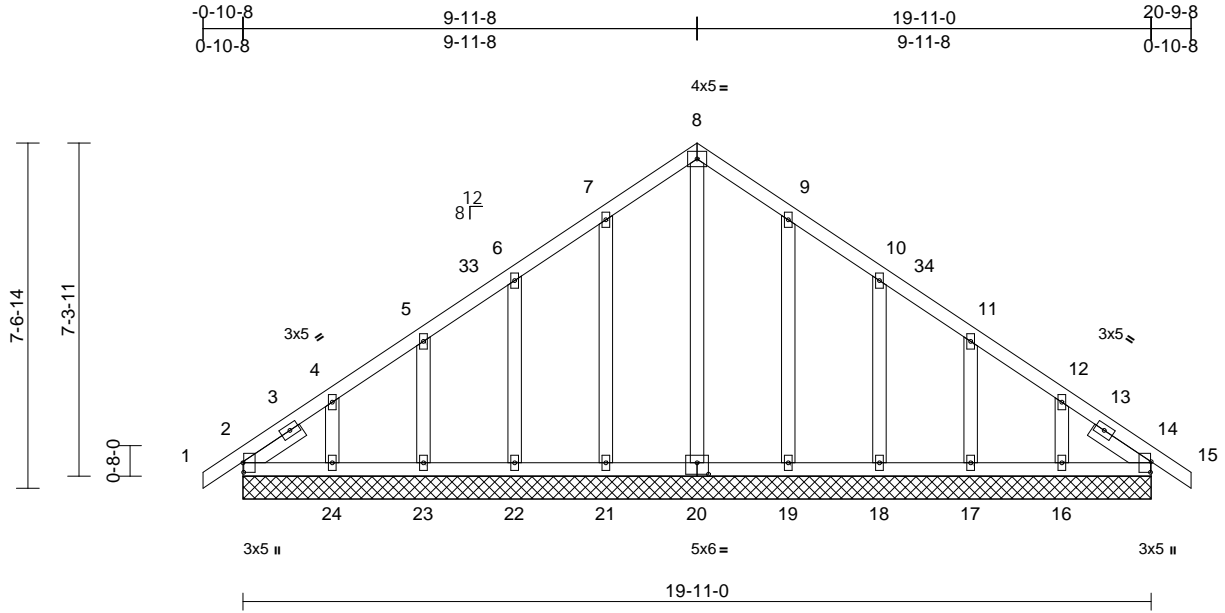

Scale = 1:50.5

Plate Offsets (X, Y): [2:0-2-8,0-0-3], [14:0-2-13,0-0-3], [20:0-3-0,0-3-0]

Loading	(psf)	Spacing	2-0-0	CSI	DEFL	in	(loc)	l/defl	L/d	PLATES	GRIP	
TCLL (roof)	20.0	Plate Grip DOL	1.15	TC	0.08	Vert(LL)	n/a	-	n/a	999	MT20	244/190
Snow (Pf)	20.0	Lumber DOL	1.15	BC	0.04	Vert(CT)	n/a	-	n/a	999		
TCDL	10.0	Rep Stress Incr	YES	WB	0.14	Horz(CT)	0.00	14	n/a	n/a		
BCLL	0.0*	Code	IRC2018/TPI2014	Matrix-MSH								
BCDL	10.0											
											Weight: 124 lb	FT = 20%

LUMBER
TOP CHORD 2x4 SP No.2
BOT CHORD 2x4 SP No.2
OTHERS 2x4 SP No.3
SLIDER Left 2x4 SP No.3 -- 1-6-0, Right 2x4 SP No.3 -- 1-6-0

BRACING
TOP CHORD Structural wood sheathing directly applied or 6-0-0 oc purlins.
BOT CHORD Rigid ceiling directly applied or 10-0-0 oc bracing.

REACTIONS (size) 2=19-11-0, 14=19-11-0, 16=19-11-0, 17=19-11-0, 18=19-11-0, 19=19-11-0, 20=19-11-0, 21=19-11-0, 22=19-11-0, 23=19-11-0, 24=19-11-0, 25=19-11-0, 29=19-11-0
Max Horiz 2=170 (LC 13), 25=170 (LC 13)
Max Uplift 2=43 (LC 10), 14=3 (LC 11), 16=86 (LC 15), 17=52 (LC 15), 18=62 (LC 15), 19=56 (LC 15), 21=58 (LC 14), 22=61 (LC 14), 23=50 (LC 14), 24=94 (LC 14), 25=43 (LC 10), 29=3 (LC 11)
Max Grav 2=167 (LC 26), 14=146 (LC 22), 16=178 (LC 26), 17=166 (LC 26), 18=222 (LC 22), 19=259 (LC 22), 20=167 (LC 28), 21=259 (LC 21), 22=222 (LC 21), 23=165 (LC 25), 24=187 (LC 25), 25=167 (LC 26), 29=146 (LC 22)

FORCES (lb) - Maximum Compression/Maximum Tension

TOP CHORD 1-2=0/29, 2-4=-145/128, 4-5=-116/97, 5-6=-105/90, 6-7=-92/125, 7-8=-113/184, 8-9=-113/184, 9-10=-87/125, 10-11=-63/61, 11-12=-73/40, 12-14=-103/66, 14-15=0/29
BOT CHORD 2-24=-55/128, 23-24=-55/128, 22-23=-55/128, 21-22=-55/128, 19-21=-55/128, 18-19=-55/128, 17-18=-55/128, 16-17=-55/128, 14-16=-55/128
WEBS 8-20=-141/28, 7-21=-219/84, 6-22=-182/91, 5-23=-143/85, 4-24=-145/103, 9-19=-219/84, 10-18=-182/91, 11-17=-143/85, 12-16=-145/103

NOTES
1) Unbalanced roof live loads have been considered for this design.
2) Wind: ASCE 7-16; Vult=130mph (3-second gust) Vasd=103mph; TCDL=6.0psf; BCDL=6.0psf; h=25ft; Cat. II; Exp B; Enclosed; MWFRS (envelope) exterior zone and C-C Corner(3E) -0-10-8 to 1-11-8, Exterior(2N) 1-11-8 to 6-11-8, Corner(3R) 6-11-8 to 12-11-8, Exterior (2N) 12-11-8 to 17-9-8, Corner(3E) 17-9-8 to 20-9-8 zone; cantilever left and right exposed ; end vertical left and right exposed;C-C for members and forces & MWFRS for reactions shown; Lumber DOL=1.60 plate grip DOL=1.60
3) Truss designed for wind loads in the plane of the truss only. For studs exposed to wind (normal to the face), see Standard Industry Gable End Details as applicable, or consult qualified building designer as per ANSI/TPI 1.
4) TCLL: ASCE 7-16; Pr=20.0 psf (roof LL: Lum DOL=1.15 Plate DOL=1.15); Pf=20.0 psf (Lum DOL=1.15 Plate DOL=1.15); Is=1.0; Rough Cat B; Fully Exp.; Ce=0.9; Cs=1.00; Ct=1.10
5) Unbalanced snow loads have been considered for this design.

6) This truss has been designed for greater of min roof live load of 12.0 psf or 1.00 times flat roof load of 20.0 psf on overhangs non-concurrent with other live loads.
7) All plates are 2x4 MT20 unless otherwise indicated.
8) Gable requires continuous bottom chord bearing.
9) Gable studs spaced at 2-0-0 oc.
10) This truss has been designed for a 10.0 psf bottom chord live load nonconcurrent with any other live loads.
11) * This truss has been designed for a live load of 20.0psf on the bottom chord in all areas where a rectangle 3-06-00 tall by 2-00-00 wide will fit between the bottom chord and any other members.
12) N/A

13) Beveled plate or shim required to provide full bearing surface with truss chord at joint(s) 14, 29.
14) This truss is designed in accordance with the 2018 International Residential Code sections R502.11.1 and R802.10.2 and referenced standard ANSI/TPI 1.



April 1, 2024

Continued on page 2

WARNING - Verify design parameters and READ NOTES ON THIS AND INCLUDED MITEK REFERENCE PAGE MII-7473 rev. 1/2/2023 BEFORE USE.

Design valid for use only with MiTek® connectors. This design is based only upon parameters shown, and is for an individual building component, not a truss system. Before use, the building designer must verify the applicability of design parameters and properly incorporate this design into the overall building design. Bracing indicated is to prevent buckling of individual truss web and/or chord members only. Additional temporary and permanent bracing is always required for stability and to prevent collapse with possible personal injury and property damage. For general guidance regarding the fabrication, storage, delivery, erection and bracing of trusses and truss systems, see **ANSI/TPI Quality Criteria and DSB-22** available from Truss Plate Institute (www.tpinst.org) and **BCSI Building Component Safety Information** available from the Structural Building Component Association (www.sbcacomponents.com)



818 Soundside Road
Edenton, NC 27932

Job 24030153-01	Truss DSE	Truss Type Common Supported Gable	Qty 1	Ply 1	142 Serenity-Roof-B329 B LH CP Job Reference (optional)	I64576256
--------------------	--------------	--------------------------------------	----------	----------	--	-----------

Carter Components (Sanford, NC), Sanford, NC - 27332,

Run: 9.03 S 8.73 Mar 21 2024 Print: 8.730 S Mar 21 2024 MiTek Industries, Inc. Fri Mar 29 10:41:41
ID:scQGvP9BX7kqzqHzzoTKiTzMKCE-RfC?PsB70Hq3NSgPqnL8w3ulTXbGKWrCDoi7J4zJC?f

Page: 2

LOAD CASE(S) Standard

WARNING - Verify design parameters and READ NOTES ON THIS AND INCLUDED MITEK REFERENCE PAGE MII-7473 rev. 1/2/2023 BEFORE USE.

Design valid for use only with MiTek® connectors. This design is based only upon parameters shown, and is for an individual building component, not a truss system. Before use, the building designer must verify the applicability of design parameters and properly incorporate this design into the overall building design. Bracing indicated is to prevent buckling of individual truss web and/or chord members only. Additional temporary and permanent bracing is always required for stability and to prevent collapse with possible personal injury and property damage. For general guidance regarding the fabrication, storage, delivery, erection and bracing of trusses and truss systems, see **ANSI/TP1 Quality Criteria and DSB-22** available from Truss Plate Institute (www.tpinst.org) and **BCSI Building Component Safety Information** available from the Structural Building Component Association (www.sbcacomponents.com)



818 Soundside Road
Edenton, NC 27932

Job 24030153-01	Truss D	Truss Type Common	Qty 9	Ply 1	142 Serenity-Roof-B329 B LH CP Job Reference (optional)	I64576257
--------------------	------------	----------------------	----------	----------	--	-----------

Carter Components (Sanford, NC), Sanford, NC - 27332,

Run: 9.03 S 8.73 Mar 21 2024 Print: 8.730 S Mar 21 2024 MiTek Industries, Inc. Fri Mar 29 10:41:41
ID:hUF6be17ILO98xsq?mix9zMKCP-RfC?PsB70Hq3NSgPqnL8w3uTXbGKWrCDoi7J4zJC7f

Page: 1

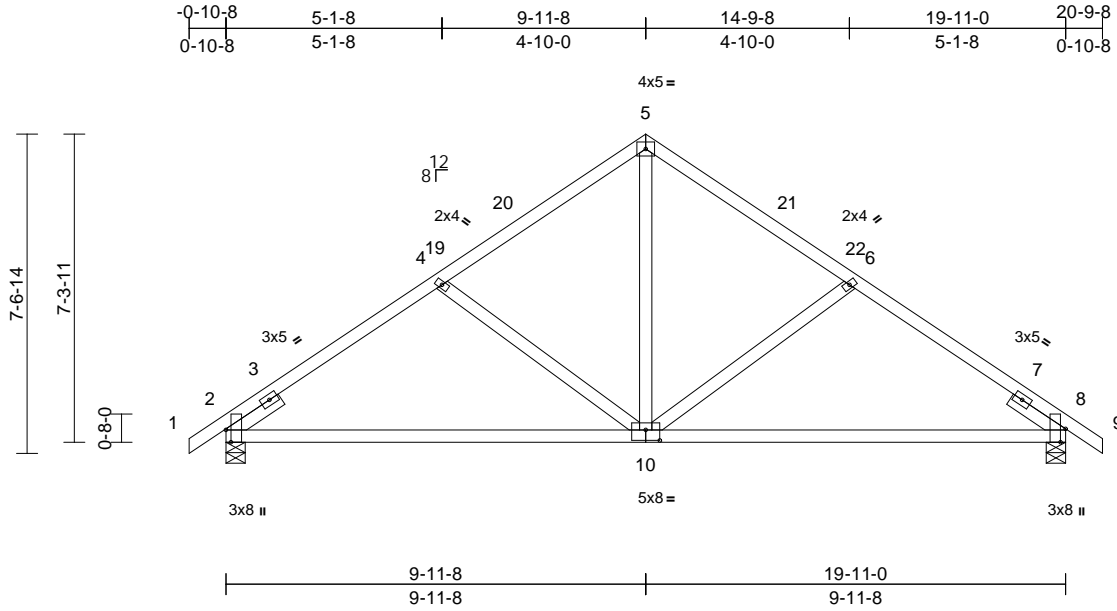

Scale = 1:54.7

Plate Offsets (X, Y): [2:0-3-8,Edge], [8:0-3-13,Edge], [10:0-4-0,0-3-0]

Loading	(psf)	Spacing	2-0-0	CSI	DEFL	in	(loc)	l/defl	L/d	PLATES	GRIP	
TCLL (roof)	20.0	Plate Grip DOL	1.15	TC	0.51	Vert(LL)	-0.13	10-17	>999	240	MT20	244/190
Snow (Pf)	20.0	Lumber DOL	1.15	BC	0.83	Vert(CT)	-0.27	10-17	>875	180		
TCDL	10.0	Rep Stress Incr	YES	WB	0.27	Horz(CT)	0.02	8	n/a	n/a		
BCLL	0.0*	Code	IRC2018/TPI2014	Matrix-MSH								
BCDL	10.0											
											Weight: 101 lb	FT = 20%

LUMBER

- TOP CHORD 2x4 SP No.2
- BOT CHORD 2x4 SP No.2
- WEBS 2x4 SP No.3
- SLIDER Left 2x4 SP No.3 -- 1-6-0, Right 2x4 SP No.3 -- 1-6-0

BRACING

- TOP CHORD Structural wood sheathing directly applied or 5-4-1 oc purlins.
- BOT CHORD Rigid ceiling directly applied or 10-0-0 oc bracing.

REACTIONS

- (size) 2=0-5-8, 8=0-5-8
- Max Horiz 2=170 (LC 13)
- Max Uplift 2=-85 (LC 14), 8=-85 (LC 15)
- Max Grav 2=897 (LC 21), 8=897 (LC 22)

FORCES

- (lb) - Maximum Compression/Maximum Tension
- TOP CHORD 1-2=0/29, 2-4=-1006/147, 4-5=-875/137, 5-6=-875/137, 6-8=-1006/147, 8-9=0/29
- BOT CHORD 2-8=-193/897
- WEBS 5-10=-29/593, 6-10=-366/183, 4-10=-366/183

NOTES

- Unbalanced roof live loads have been considered for this design.
- Wind: ASCE 7-16; Vult=130mph (3-second gust) Vasd=103mph; TCDL=6.0psf; BCDL=6.0psf; h=25ft; Cat. II; Exp B; Enclosed; MWFRS (envelope) exterior zone and C-C Exterior(2E) -0-10-8 to 2-1-8, Interior (1) 2-1-8 to 6-11-8, Exterior(2R) 6-11-8 to 12-11-8, Interior (1) 12-11-8 to 17-9-8, Exterior(2E) 17-9-8 to 20-9-8 zone; cantilever left and right exposed ; end vertical left and right exposed;C-C for members and forces & MWFRS for reactions shown; Lumber DOL=1.60 plate grip DOL=1.60

- TCLL: ASCE 7-16; Pr=20.0 psf (roof LL: Lum DOL=1.15 Plate DOL=1.15); Pf=20.0 psf (Lum DOL=1.15 Plate DOL=1.15); Is=1.0; Rough Cat B; Fully Exp.; Ce=0.9; Cs=1.00; Ct=1.10
- Unbalanced snow loads have been considered for this design.
- This truss has been designed for greater of min roof live load of 12.0 psf or 1.00 times flat roof load of 20.0 psf on overhangs non-concurrent with other live loads.
- This truss has been designed for a 10.0 psf bottom chord live load nonconcurrent with any other live loads.
- * This truss has been designed for a live load of 20.0psf on the bottom chord in all areas where a rectangle 3-06-00 tall by 2-00-00 wide will fit between the bottom chord and any other members.
- One H2.5A Simpson Strong-Tie connectors recommended to connect truss to bearing walls due to UPLIFT at jt(s) 2 and 8. This connection is for uplift only and does not consider lateral forces.
- This truss is designed in accordance with the 2018 International Residential Code sections R502.11.1 and R802.10.2 and referenced standard ANSI/TPI 1.

LOAD CASE(S) Standard

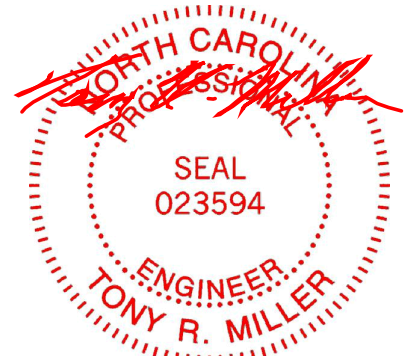

April 1, 2024

WARNING - Verify design parameters and READ NOTES ON THIS AND INCLUDED MITEK REFERENCE PAGE MII-7473 rev. 1/2/2023 BEFORE USE.

Design valid for use only with MiTek® connectors. This design is based only upon parameters shown, and is for an individual building component, not a truss system. Before use, the building designer must verify the applicability of design parameters and properly incorporate this design into the overall building design. Bracing indicated is to prevent buckling of individual truss web and/or chord members only. Additional temporary and permanent bracing is always required for stability and to prevent collapse with possible personal injury and property damage. For general guidance regarding the fabrication, storage, delivery, erection and bracing of trusses and truss systems, see **ANSI/TPI Quality Criteria and DSB-22** available from Truss Plate Institute (www.tpinst.org) and **BCSI Building Component Safety Information** available from the Structural Building Component Association (www.sbcacomponents.com)



818 Soundside Road
Edenton, NC 27932

Job 24030153-01	Truss D1	Truss Type Common	Qty 2	Ply 1	142 Serenity-Roof-B329 B LH CP Job Reference (optional)	I64576258
--------------------	-------------	----------------------	----------	----------	--	-----------

Carter Components (Sanford, NC), Sanford, NC - 27332,

Run: 9.03 S 8.73 Mar 21 2024 Print: 8.730 S Mar 21 2024 MiTek Industries, Inc. Fri Mar 29 10:41:41
ID:Z_zCtCt8BmiE58RMZm1ivPzMcKc-RfC?PsB70Hq3NSgPqnL8w3uITXbGKwRcD0i7J4zJC?#

Page: 1

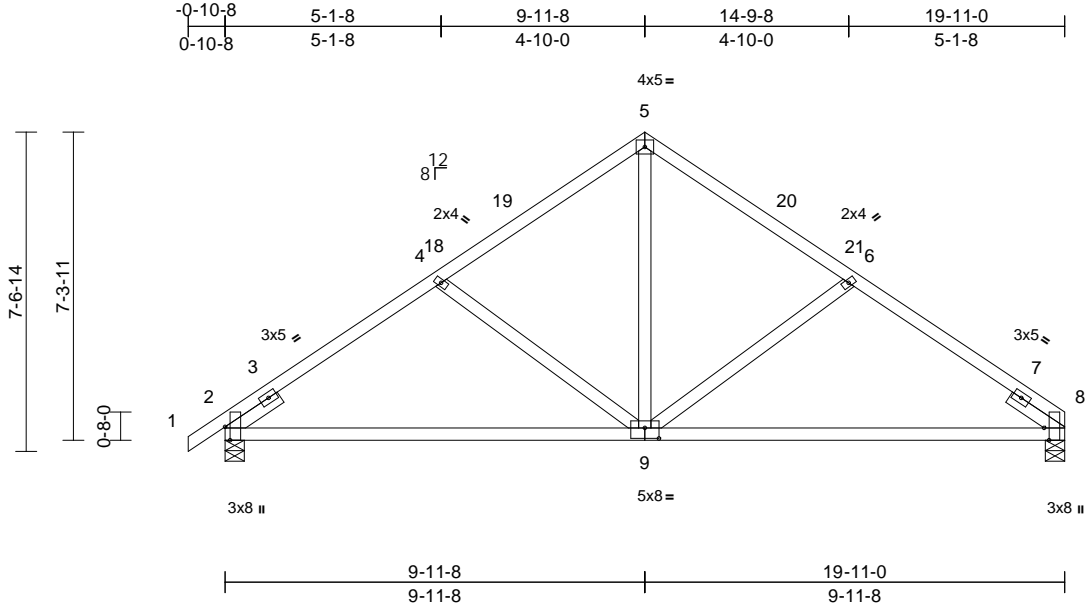

Scale = 1:54.7

Plate Offsets (X, Y): [2:0-3-13,Edge], [8:0-3-8,Edge], [9:0-4-0,0-3-0]

Loading	(psf)	Spacing	2-0-0	CSI	DEFL	in	(loc)	l/defl	L/d	PLATES	GRIP	
TCLL (roof)	20.0	Plate Grip DOL	1.15	TC	0.51	Vert(LL)	-0.13	9-12	>999	240	MT20	244/190
Snow (Pf)	20.0	Lumber DOL	1.15	BC	0.83	Vert(CT)	-0.28	9-12	>868	180		
TCDL	10.0	Rep Stress Incr	YES	WB	0.27	Horz(CT)	0.02	8	n/a	n/a		
BCLL	0.0*	Code	IRC2018/TPI2014	Matrix-MSH								
BCDL	10.0											
											Weight: 99 lb	FT = 20%

LUMBER

TOP CHORD 2x4 SP No.2
 BOT CHORD 2x4 SP No.2
 WEBS 2x4 SP No.3
 SLIDER Left 2x4 SP No.3 -- 1-6-0, Right 2x4 SP No.3 -- 1-6-0

BRACING

TOP CHORD Structural wood sheathing directly applied or 5-4-1 oc purlins.
 BOT CHORD Rigid ceiling directly applied or 10-0-0 oc bracing.

REACTIONS

(size) 2=0-5-8, 8=0-5-8
 Max Horiz 2=165 (LC 13)
 Max Uplift 2=-85 (LC 14), 8=-67 (LC 15)
 Max Grav 2=897 (LC 21), 8=843 (LC 22)

FORCES

(lb) - Maximum Compression/Maximum Tension
 TOP CHORD 1-2=0/29, 2-4=-1007/148, 4-5=-876/139, 5-6=-877/139, 6-8=-1010/149
 BOT CHORD 2-8=-200/903
 WEBS 5-9=-31/595, 6-9=-370/184, 4-9=-366/183

NOTES

- 1) Unbalanced roof live loads have been considered for this design.
- 2) Wind: ASCE 7-16; Vult=130mph (3-second gust) Vasd=103mph; TCDL=6.0psf; BCDL=6.0psf; h=25ft; Cat. II; Exp B; Enclosed; MWFRS (envelope) exterior zone and C-C Exterior(2E) -0-10-8 to 2-1-8, Interior (1) 2-1-8 to 6-11-8, Exterior(2R) 6-11-8 to 12-11-8, Interior (1) 12-11-8 to 16-11-0, Exterior(2E) 16-11-0 to 19-11-0 zone; cantilever left and right exposed; end vertical left and right exposed; C-C for members and forces & MWFRS for reactions shown; Lumber DOL=1.60 plate grip DOL=1.60

- 3) TCLL: ASCE 7-16; Pr=20.0 psf (roof LL: Lum DOL=1.15 Plate DOL=1.15); Pf=20.0 psf (Lum DOL=1.15 Plate DOL=1.15); Is=1.0; Rough Cat B; Fully Exp.; Ce=0.9; Cs=1.00; Ct=1.10
- 4) Unbalanced snow loads have been considered for this design.
- 5) This truss has been designed for greater of min roof live load of 12.0 psf or 1.00 times flat roof load of 20.0 psf on overhangs non-concurrent with other live loads.
- 6) This truss has been designed for a 10.0 psf bottom chord live load nonconcurrent with any other live loads.
- 7) * This truss has been designed for a live load of 20.0psf on the bottom chord in all areas where a rectangle 3-06-00 tall by 2-00-00 wide will fit between the bottom chord and any other members.
- 8) One H2.5A Simpson Strong-Tie connectors recommended to connect truss to bearing walls due to UPLIFT at jt(s) 8 and 2. This connection is for uplift only and does not consider lateral forces.
- 9) This truss is designed in accordance with the 2018 International Residential Code sections R502.11.1 and R802.10.2 and referenced standard ANSI/TPI 1.

LOAD CASE(S) Standard

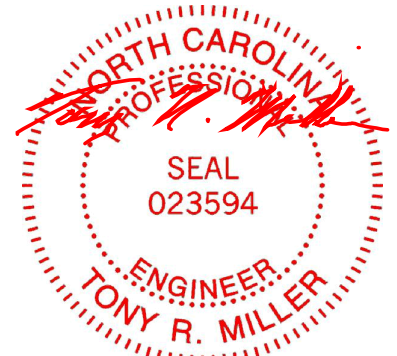

April 1, 2024

WARNING - Verify design parameters and READ NOTES ON THIS AND INCLUDED MITEK REFERENCE PAGE MII-7473 rev. 1/2/2023 BEFORE USE.

Design valid for use only with MiTek® connectors. This design is based only upon parameters shown, and is for an individual building component, not a truss system. Before use, the building designer must verify the applicability of design parameters and properly incorporate this design into the overall building design. Bracing indicated is to prevent buckling of individual truss web and/or chord members only. Additional temporary and permanent bracing is always required for stability and to prevent collapse with possible personal injury and property damage. For general guidance regarding the fabrication, storage, delivery, erection and bracing of trusses and truss systems, see **ANSI/TPH Quality Criteria and DSB-22** available from Truss Plate Institute (www.tpinst.org) and **BCSI Building Component Safety Information** available from the Structural Building Component Association (www.sbcacomponents.com)



818 Soundside Road
 Edenton, NC 27932

Job 24030153-01	Truss B1	Truss Type Hip	Qty 1	Ply 1	142 Serenity-Roof-B329 B LH CP Job Reference (optional)	I64576259
--------------------	-------------	-------------------	----------	----------	--	-----------

Carter Components (Sanford, NC), Sanford, NC - 27332,

Run: 9.03 S 8.73 Mar 21 2024 Print: 8.730 S Mar 21 2024 MiTek Industries, Inc. Fri Mar 29 10:41:39
ID:A4ZwKcHPRJy77vzWsgkq2UzMCQX-RfC?PsB70Hq3NSgPqnL8w3ulTXbGKwRCDoi7J4zJC?f

Page: 1

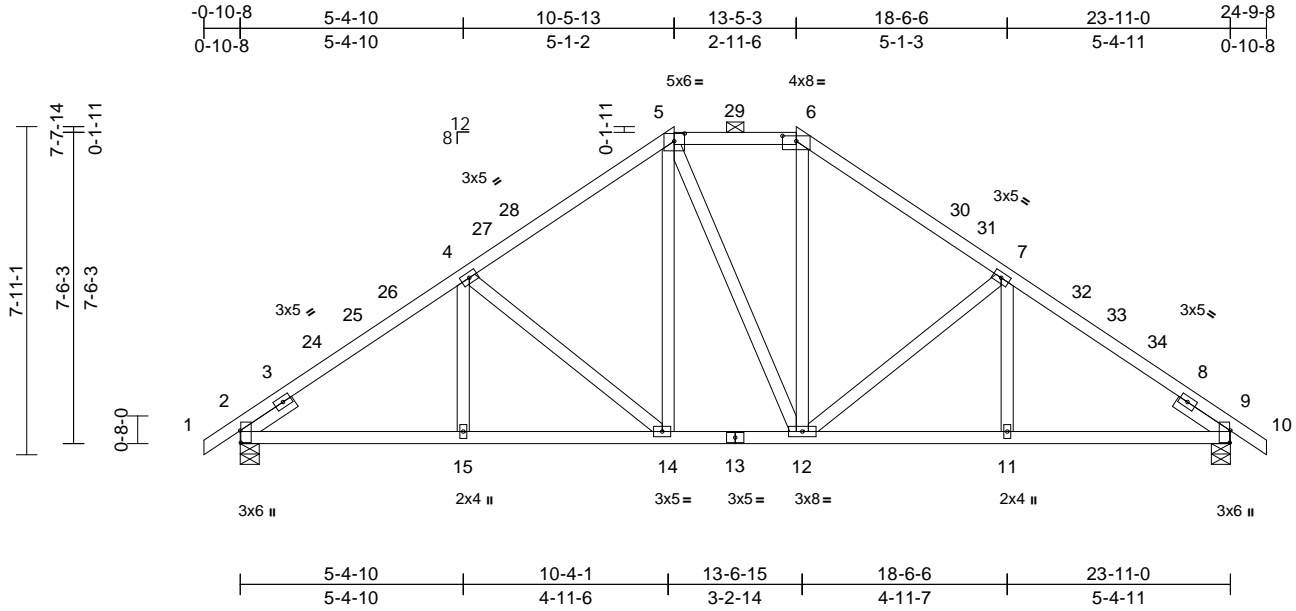

Scale = 1:55.7

Plate Offsets (X, Y): [2:0-3-9,0-0-3], [5:0-3-0,0-2-3], [6:0-4-0,0-1-9], [9:0-3-9,0-0-3]

Loading	(psf)	Spacing	2-0-0	CSI	DEFL	in	(loc)	l/defl	L/d	PLATES	GRIP	
TCLL (roof)	20.0	Plate Grip DOL	1.15	TC	0.57	Vert(LL)	-0.06	14-15	>999	240	MT20	244/190
Snow (Pf)	20.0	Lumber DOL	1.15	BC	0.56	Vert(CT)	-0.12	14-15	>999	180		
TCDL	10.0	Rep Stress Incr	YES	WB	0.34	Horz(CT)	0.05	9	n/a	n/a		
BCLL	0.0*	Code	IRC2018/TPI2014	Matrix-MSH								
BCDL	10.0											
											Weight: 146 lb	FT = 20%

LUMBER
TOP CHORD 2x4 SP No.2
BOT CHORD 2x4 SP No.2
WEBS 2x4 SP No.3
SLIDER Left 2x4 SP No.3 -- 1-6-0, Right 2x4 SP No.3 -- 1-6-0

BRACING
TOP CHORD Structural wood sheathing directly applied or 4-1-6 oc purlins, except 2-0-0 oc purlins (5-9-6 max.): 5-6.
BOT CHORD Rigid ceiling directly applied or 10-0-0 oc bracing.

REACTIONS (size) 2=0-5-8, 9=0-5-8
Max Horiz 2=176 (LC 13)
Max Uplift 2=-104 (LC 14), 9=-104 (LC 15)
Max Grav 2=1209 (LC 41), 9=1209 (LC 41)

FORCES (lb) - Maximum Compression/Maximum Tension
TOP CHORD 1-2=0/29, 2-4=-1647/136, 4-5=-1287/169, 5-6=-957/181, 6-7=-1288/169, 7-9=-1646/137, 9-10=0/29
BOT CHORD 2-15=-171/1305, 14-15=-135/1305, 12-14=-10/954, 11-12=-16/1305, 9-11=-76/1305
WEBS 4-15=0/191, 4-14=-452/158, 5-14=-47/363, 5-12=-148/153, 6-12=-38/362, 7-12=-451/158, 7-11=0/190

NOTES
1) Unbalanced roof live loads have been considered for this design.

- Wind: ASCE 7-16; Vult=130mph (3-second gust) Vasd=103mph; TCDL=6.0psf; BCDL=6.0psf; h=25ft; Cat. II; Exp B; Enclosed; MWFRS (envelope) exterior zone and C-C Exterior(2E) -0-10-8 to 2-1-8, Interior (1) 2-1-8 to 6-2-14, Exterior(2R) 6-2-14 to 17-8-2, Interior (1) 17-8-2 to 21-9-8, Exterior(2E) 21-9-8 to 24-9-8 zone; cantilever left and right exposed; end vertical left and right exposed; C-C for members and forces & MWFRS for reactions shown; Lumber DOL=1.60 plate grip DOL=1.60
- TCLL: ASCE 7-16; Pr=20.0 psf (roof LL: Lum DOL=1.15 Plate DOL=1.15); Pf=20.0 psf (Lum DOL=1.15 Plate DOL=1.15); Is=1.0; Rough Cat B; Fully Exp.; Ce=0.9; Cs=1.00; Ct=1.10
- Unbalanced snow loads have been considered for this design.
- This truss has been designed for greater of min roof live load of 12.0 psf or 1.00 times flat roof load of 20.0 psf on overhangs non-concurrent with other live loads.
- Provide adequate drainage to prevent water ponding.
- This truss has been designed for a 10.0 psf bottom chord live load nonconcurrent with any other live loads.
- * This truss has been designed for a live load of 20.0psf on the bottom chord in all areas where a rectangle 3-06-00 tall by 2-00-00 wide will fit between the bottom chord and any other members.
- One H2.5A Simpson Strong-Tie connectors recommended to connect truss to bearing walls due to UPLIFT at jt(s) 2 and 9. This connection is for uplift only and does not consider lateral forces.
- This truss is designed in accordance with the 2018 International Residential Code sections R502.11.1 and R802.10.2 and referenced standard ANSI/TPI 1.
- Graphical purlin representation does not depict the size or the orientation of the purlin along the top and/or bottom chord.

LOAD CASE(S) Standard



April 1, 2024

WARNING - Verify design parameters and READ NOTES ON THIS AND INCLUDED MITEK REFERENCE PAGE MII-7473 rev. 1/2/2023 BEFORE USE.

Design valid for use only with MiTek® connectors. This design is based only upon parameters shown, and is for an individual building component, not a truss system. Before use, the building designer must verify the applicability of design parameters and properly incorporate this design into the overall building design. Bracing indicated is to prevent buckling of individual truss web and/or chord members only. Additional temporary and permanent bracing is always required for stability and to prevent collapse with possible personal injury and property damage. For general guidance regarding the fabrication, storage, delivery, erection and bracing of trusses and truss systems, see **ANSI/TPI1 Quality Criteria and DSB-22** available from Truss Plate Institute (www.tpinst.org) and **BCSI Building Component Safety Information** available from the Structural Building Component Association (www.sbcacomponents.com)

ENGINEERING BY
TRENCO
A MiTek Affiliate

818 Soundside Road
Edenton, NC 27932

Job 24030153-01	Truss B2	Truss Type Roof Special	Qty 1	Ply 1	142 Serenity-Roof-B329 B LH CP Job Reference (optional)	164576260
--------------------	-------------	----------------------------	----------	----------	--	-----------

Carter Components (Sanford, NC), Sanford, NC - 27332,

Run: 9.03 S 8.73 Mar 21 2024 Print: 8.730 S Mar 21 2024 MITek Industries, Inc. Fri Mar 29 10:41:39
ID:TVbG3FBSnMPMdQCxIwaQalzMCPM-RfC?PsB70Hq3NSgPqnL8w3ulTXbGKwRCDoi7J4zJC?f

Page: 1

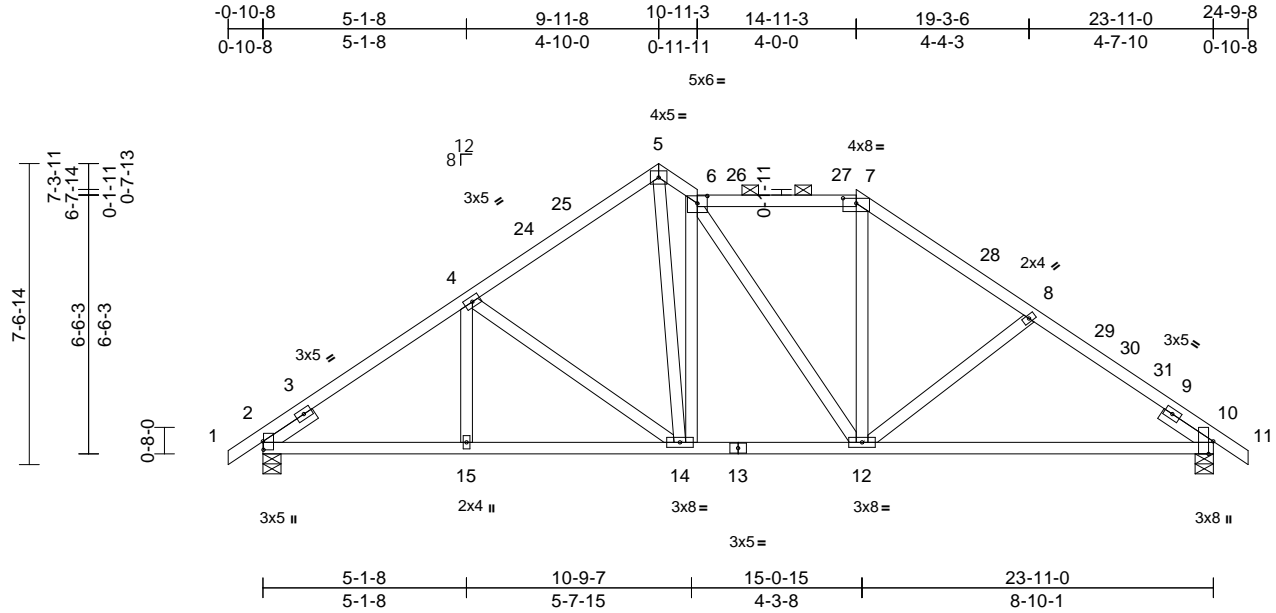

Scale = 1:58

Plate Offsets (X, Y): [2:0-2-9,0-0-3], [6:0-3-0,0-2-4], [7:0-4-0,0-1-9], [10:0-3-13,Edge]

Loading	(psf)	Spacing	2-0-0	CSI	DEFL	in	(loc)	l/defl	L/d	PLATES	GRIP	
TCLL (roof)	20.0	Plate Grip DOL	1.15	TC	0.49	Vert(LL)	-0.11	12-22	>999	240	MT20	244/190
Snow (Pf)	20.0	Lumber DOL	1.15	BC	0.61	Vert(CT)	-0.23	12-22	>999	180		
TCDL	10.0	Rep Stress Incr	YES	WB	0.67	Horz(CT)	0.04	10	n/a	n/a		
BCLL	0.0*	Code	IRC2018/TPI2014	Matrix-MSH								
BCDL	10.0											
											Weight: 146 lb	FT = 20%

LUMBER
TOP CHORD 2x4 SP No.2
BOT CHORD 2x4 SP No.2
WEBS 2x4 SP No.3
SLIDER Left 2x4 SP No.3 -- 1-6-0, Right 2x4 SP No.3 -- 1-6-0

BRACING
TOP CHORD Structural wood sheathing directly applied or 4-8-4 oc purlins, except 2-0-0 oc purlins (5-3-9 max.): 6-7.
BOT CHORD Rigid ceiling directly applied or 10-0-0 oc bracing.

REACTIONS (size) 2=0-5-8, 10=0-5-8
Max Horiz 2=170 (LC 13)
Max Uplift 2=-88 (LC 14), 10=-120 (LC 15)
Max Grav 2=1031 (LC 21), 10=1093 (LC 43)

FORCES (lb) - Maximum Compression/Maximum Tension
TOP CHORD 1-2=0/29, 2-4=-1409/146, 4-5=-1114/180, 5-6=-1154/218, 6-7=-975/182, 7-8=-1229/173, 8-10=-1479/185, 10-11=0/29
BOT CHORD 2-15=-152/1103, 14-15=-111/1103, 12-14=0/949, 10-12=-111/1166
WEBS 4-15=0/198, 4-14=-403/149, 5-14=-155/1031, 6-14=-835/190, 6-12=-176/110, 7-12=0/354, 8-12=-354/152

NOTES
1) Unbalanced roof live loads have been considered for this design.

- Wind: ASCE 7-16; Vult=130mph (3-second gust) Vasd=103mph; TCDL=6.0psf; BCDL=6.0psf; h=25ft; Cat. II; Exp B; Enclosed; MWFRS (envelope) exterior zone and C-C Exterior(2E) -0-10-8 to 2-1-8, Interior (1) 2-1-8 to 6-11-8, Exterior(2R) 6-11-8 to 9-11-8, Exterior(2E) 9-11-8 to 10-11-3, Interior (1) 10-11-3 to 11-11-3, Exterior (2R) 11-11-3 to 17-11-3, Interior (1) 17-11-3 to 21-9-8, Exterior(2E) 21-9-8 to 24-9-8 zone; cantilever left and right exposed; end vertical left and right exposed; C-C for members and forces & MWFRS for reactions shown; Lumber DOL=1.60 plate grip DOL=1.60
- TCLL: ASCE 7-16; Pr=20.0 psf (roof LL: Lum DOL=1.15 Plate DOL=1.15); Pf=20.0 psf (Lum DOL=1.15 Plate DOL=1.15); Is=1.0; Rough Cat B; Fully Exp.; Ce=0.9; Cs=1.00; Ct=1.10
- Unbalanced snow loads have been considered for this design.
- This truss has been designed for greater of min roof live load of 12.0 psf or 1.00 times flat roof load of 20.0 psf on overhangs non-concurrent with other live loads.
- Provide adequate drainage to prevent water ponding.
- This truss has been designed for a 10.0 psf bottom chord live load nonconcurrent with any other live loads.
- * This truss has been designed for a live load of 20.0psf on the bottom chord in all areas where a rectangle 3-06-00 tall by 2-00-00 wide will fit between the bottom chord and any other members.
- One H2.5A Simpson Strong-Tie connectors recommended to connect truss to bearing walls due to UPLIFT at jt(s) 2 and 10. This connection is for uplift only and does not consider lateral forces.
- This truss is designed in accordance with the 2018 International Residential Code sections R502.11.1 and R802.10.2 and referenced standard ANSI/TPI 1.
- Graphical purlin representation does not depict the size or the orientation of the purlin along the top and/or bottom chord.

LOAD CASE(S) Standard



April 1, 2024

WARNING - Verify design parameters and READ NOTES ON THIS AND INCLUDED MITEK REFERENCE PAGE MII-7473 rev. 1/2/2023 BEFORE USE.

Design valid for use only with MITek® connectors. This design is based only upon parameters shown, and is for an individual building component, not a truss system. Before use, the building designer must verify the applicability of design parameters and properly incorporate this design into the overall building design. Bracing indicated is to prevent buckling of individual truss web and/or chord members only. Additional temporary and permanent bracing is always required for stability and to prevent collapse with possible personal injury and property damage. For general guidance regarding the fabrication, storage, delivery, erection and bracing of trusses and truss systems, see **ANSI/TPI Quality Criteria and DSB-22** available from Truss Plate Institute (www.tpinst.org) and **BCSI Building Component Safety Information** available from the Structural Building Component Association (www.sbcacomponents.com)

ENGINEERING BY
TRENCO
A MITek Affiliate

818 Soundside Road
Edenton, NC 27932

Job 24030153-01	Truss B3	Truss Type Roof Special	Qty 1	Ply 1	142 Serenity-Roof-B329 B LH CP Job Reference (optional)	164576261
--------------------	-------------	----------------------------	----------	----------	--	-----------

Carter Components (Sanford, NC), Sanford, NC - 27332,

Run: 9.03 S 8.73 Mar 21 2024 Print: 8.730 S Mar 21 2024 MITek Industries, Inc. Fri Mar 29 10:41:40
ID:TJB YmhpRm1q7EGckE7?N93zMCOZ-RfC?PsB70Hq3NSgPqnL8w3ulTXbGKWRCDoi7J4zJC7f

Page: 1

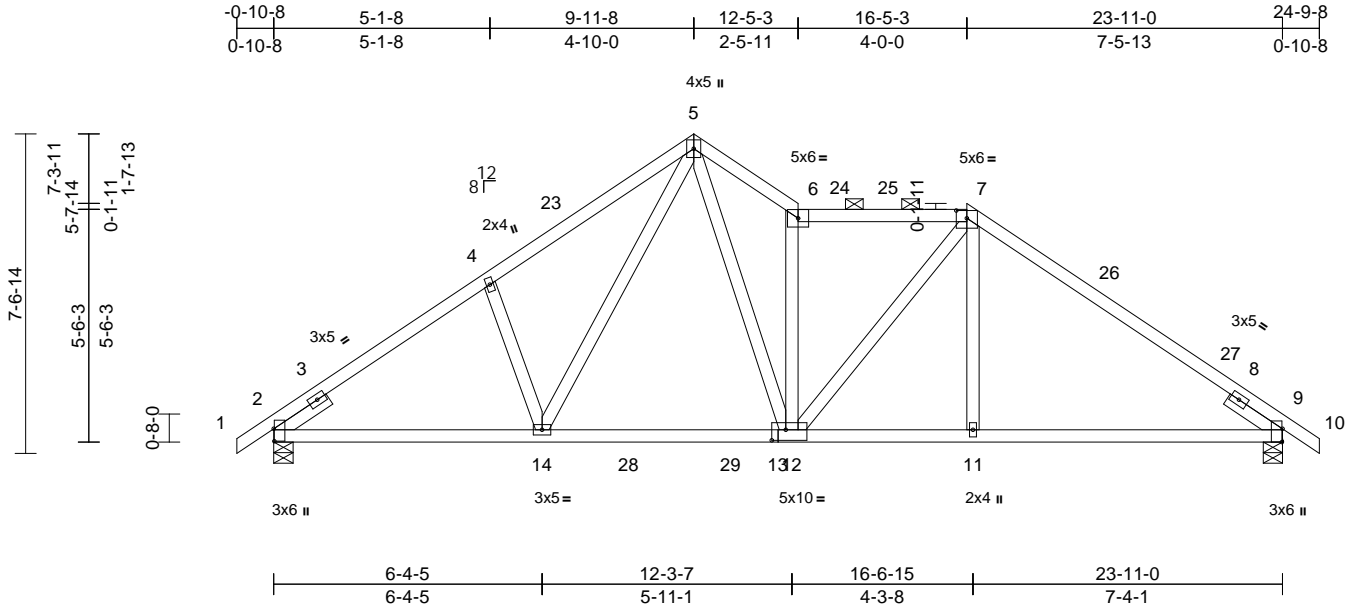

Scale = 1:54.6
Plate Offsets (X, Y): [2:0-3-9,0-0-3], [7:0-3-0,0-2-3], [9:0-3-13,Edge], [13:0-4-0,0-3-0]

Loading	(psf)	Spacing	2-0-0	CSI	DEFL	in	(loc)	l/defl	L/d	PLATES	GRIP	
TCLL (roof)	20.0	Plate Grip DOL	1.15	TC	0.88	Vert(LL)	-0.12	11-21	>999	240	MT20	244/190
Snow (Pf)	20.0	Lumber DOL	1.15	BC	0.68	Vert(CT)	-0.20	11-21	>999	180		
TCDL	10.0	Rep Stress Incr	YES	WB	0.64	Horz(CT)	0.03	9	n/a	n/a		
BCLL	0.0*	Code	IRC2018/TPI2014	Matrix-MSH								
BCDL	10.0											
											Weight: 137 lb	FT = 20%

LUMBER
TOP CHORD 2x4 SP No.2 *Except* 7-10:2x4 SP No.1
BOT CHORD 2x4 SP No.2
WEBS 2x4 SP No.3
SLIDER Left 2x4 SP No.3 -- 1-6-0, Right 2x4 SP No.3 -- 1-6-0

BRACING
TOP CHORD Structural wood sheathing directly applied or 2-2-0 oc purlins, except 2-0-0 oc purlins (4-8-8 max.): 6-7.
BOT CHORD Rigid ceiling directly applied or 10-0-0 oc bracing.

REACTIONS (size) 2=0-5-8, 9=0-5-8
Max Horiz 2=170 (LC 13)
Max Uplift 2=-88 (LC 14), 9=-120 (LC 15)
Max Grav 2=1116 (LC 25), 9=1164 (LC 51)

FORCES (lb) - Maximum Compression/Maximum Tension
TOP CHORD 1-2=0/29, 2-4=-1675/151, 4-5=-1634/218, 5-6=-1741/249, 6-7=-1441/184, 7-9=-1639/162, 9-10=0/29
BOT CHORD 2-14=-156/1323, 12-14=0/977, 11-12=-9/1221, 9-11=-196/1228
WEBS 4-14=-334/189, 5-14=-124/555, 5-12=-164/1160, 6-12=-1129/180, 7-12=-57/307, 7-11=0/266

NOTES
1) Unbalanced roof live loads have been considered for this design.

- 2) Wind: ASCE 7-16; Vult=130mph (3-second gust) Vasd=103mph; TCDL=6.0psf; BCDL=6.0psf; h=25ft; Cat. II; Exp B; Enclosed; MWFRS (envelope) exterior zone and C-C Exterior(2E) -0-10-8 to 2-1-8, Interior (1) 2-1-8 to 6-11-8, Exterior(2R) 6-11-8 to 9-11-8, Exterior(2E) 9-11-8 to 12-5-3, Interior (1) 12-5-3 to 13-5-3, Exterior (2R) 13-5-3 to 19-5-3, Interior (1) 19-5-3 to 21-9-8, Exterior(2E) 21-9-8 to 24-9-8 zone; cantilever left and right exposed; end vertical left and right exposed; C-C for members and forces & MWFRS for reactions shown; Lumber DOL=1.60 plate grip DOL=1.60
- 3) TCLL: ASCE 7-16; Pr=20.0 psf (roof LL: Lum DOL=1.15 Plate DOL=1.15); Pf=20.0 psf (Lum DOL=1.15 Plate DOL=1.15); Is=1.0; Rough Cat B; Fully Exp.; Ce=0.9; Cs=1.00; Ct=1.10
- 4) Unbalanced snow loads have been considered for this design.
- 5) This truss has been designed for greater of min roof live load of 12.0 psf or 1.00 times flat roof load of 20.0 psf on overhangs non-concurrent with other live loads.
- 6) Provide adequate drainage to prevent water ponding.
- 7) This truss has been designed for a 10.0 psf bottom chord live load nonconcurrent with any other live loads.
- 8) * This truss has been designed for a live load of 20.0psf on the bottom chord in all areas where a rectangle 3-06-00 tall by 2-00-00 wide will fit between the bottom chord and any other members, with BCDL = 10.0psf.
- 9) One H2.5A Simpson Strong-Tie connectors recommended to connect truss to bearing walls due to UPLIFT at jt(s) 2 and 9. This connection is for uplift only and does not consider lateral forces.
- 10) This truss is designed in accordance with the 2018 International Residential Code sections R502.11.1 and R802.10.2 and referenced standard ANSI/TPI 1.
- 11) Graphical purlin representation does not depict the size or the orientation of the purlin along the top and/or bottom chord.

LOAD CASE(S) Standard



April 1, 2024

WARNING - Verify design parameters and READ NOTES ON THIS AND INCLUDED MITEK REFERENCE PAGE MII-7473 rev. 1/2/2023 BEFORE USE.

Design valid for use only with MITek® connectors. This design is based only upon parameters shown, and is for an individual building component, not a truss system. Before use, the building designer must verify the applicability of design parameters and properly incorporate this design into the overall building design. Bracing indicated is to prevent buckling of individual truss web and/or chord members only. Additional temporary and permanent bracing is always required for stability and to prevent collapse with possible personal injury and property damage. For general guidance regarding the fabrication, storage, delivery, erection and bracing of trusses and truss systems, see **ANSI/TPI Quality Criteria and DSB-22** available from Truss Plate Institute (www.tpinst.org) and **BCSI Building Component Safety Information** available from the Structural Building Component Association (www.sbcacomponents.com)

ENGINEERING BY
TRENCO
A MITek Affiliate

818 Soundside Road
Edenton, NC 27932

Job 24030153-01	Truss B4	Truss Type Roof Special	Qty 1	Ply 1	142 Serenity-Roof-B329 B LH CP Job Reference (optional)	164576262
--------------------	-------------	----------------------------	----------	----------	--	-----------

Carter Components (Sanford, NC), Sanford, NC - 27332,

Run: 9.03 S 8.73 Mar 21 2024 Print: 8.730 S Mar 21 2024 MITek Industries, Inc. Fri Mar 29 10:41:40

Page: 1

ID:MMYUAt3cpTU9GVinz1tIVUzMCOE-RfC?PsB70Hq3NSgPqnL8w3ulTXbGKWRCDoi7J4zJC7f

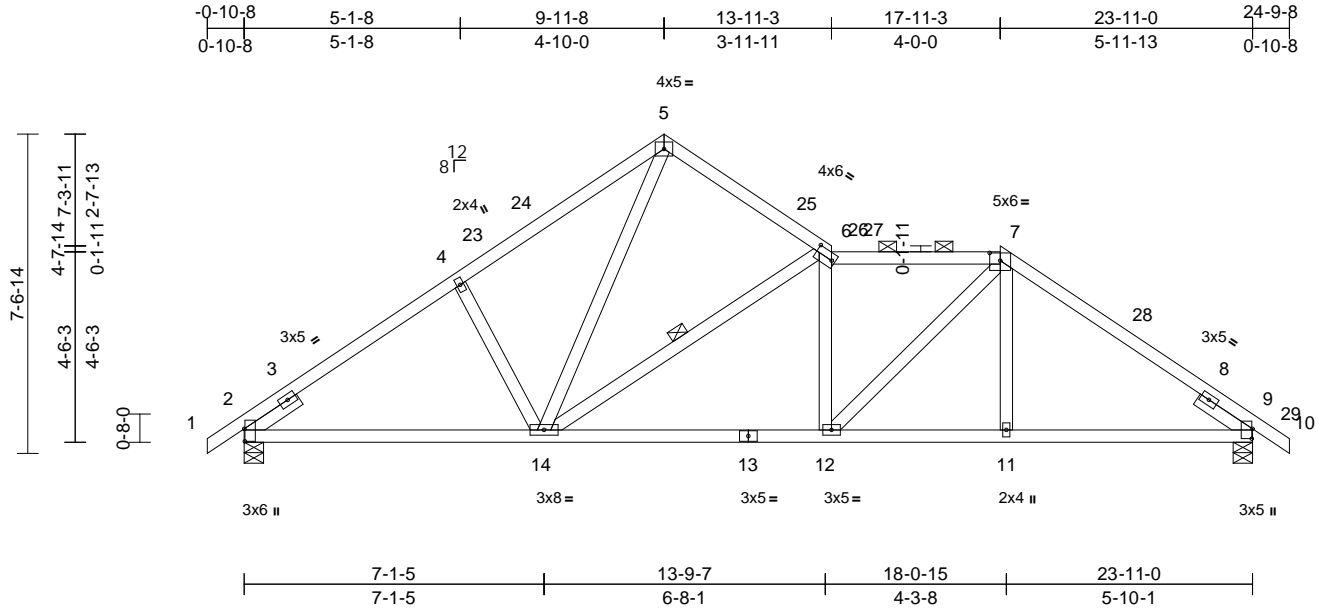

Scale = 1:54.7

Plate Offsets (X, Y): [2:0-3-9,0-0-3], [6:0-5-0,0-2-0], [7:0-3-0,0-2-3], [9:0-2-13,0-0-3]

Loading	(psf)	Spacing	2-0-0	CSI	DEFL	in	(loc)	l/defl	L/d	PLATES	GRIP	
TCLL (roof)	20.0	Plate Grip DOL	1.15	TC	0.60	Vert(LL)	-0.07	12-14	>999	240	MT20	244/190
Snow (Pf)	20.0	Lumber DOL	1.15	BC	0.52	Vert(CT)	-0.16	12-14	>999	180		
TCDL	10.0	Rep Stress Incr	YES	WB	0.37	Horz(CT)	0.05	9	n/a	n/a		
BCLL	0.0*	Code	IRC2018/TPI2014	Matrix-MSH								
BCDL	10.0											
											Weight: 134 lb	FT = 20%

LUMBER

TOP CHORD 2x4 SP No.2
 BOT CHORD 2x4 SP No.2
 WEBS 2x4 SP No.3
 SLIDER Left 2x4 SP No.3 -- 1-6-0, Right 2x4 SP No.3 -- 1-6-0

BRACING

TOP CHORD Structural wood sheathing directly applied or 3-11-11 oc purlins, except 2-0-0 oc purlins (4-4-5 max.): 6-7.
 BOT CHORD Rigid ceiling directly applied or 10-0-0 oc bracing.
 WEBS 1 Row at midpt 6-14

REACTIONS

(size) 2=0-5-8, 9=0-5-8
 Max Horiz 2=170 (LC 13)
 Max Uplift 2=-88 (LC 14), 9=-120 (LC 15)
 Max Grav 2=1074 (LC 44), 9=1142 (LC 43)

FORCES

(lb) - Maximum Compression/Maximum Tension
 TOP CHORD 1-2=0/29, 2-4=-1434/170, 4-5=-1328/214, 5-6=-872/168, 6-7=-1444/202, 7-9=-1388/170, 9-10=0/45
 BOT CHORD 2-14=-160/1141, 12-14=-47/1418, 11-12=-33/1084, 9-11=-133/1088
 WEBS 4-14=-329/182, 5-14=-108/933, 6-14=-962/160, 6-12=-248/98, 7-12=-38/507, 7-11=0/173

NOTES

1) Unbalanced roof live loads have been considered for this design.

- Wind: ASCE 7-16; Vult=130mph (3-second gust) Vasd=103mph; TCDL=6.0psf; BCDL=6.0psf; h=25ft; Cat. II; Exp B; Enclosed; MWFRS (envelope) exterior zone and C-C Exterior(2E) -0-10-8 to 2-1-8, Interior (1) 2-1-8 to 6-11-8, Exterior(2R) 6-11-8 to 12-11-8, Interior (1) 12-11-8 to 14-11-3, Exterior(2R) 14-11-3 to 20-11-3, Interior (1) 20-11-3 to 21-9-8, Exterior(2E) 21-9-8 to 24-9-8 zone; cantilever left and right exposed ; end vertical left and right exposed;C-C for members and forces & MWFRS for reactions shown; Lumber DOL=1.60 plate grip DOL=1.60
- TCLL: ASCE 7-16; Pr=20.0 psf (roof LL: Lum DOL=1.15 Plate DOL=1.15); Pf=20.0 psf (Lum DOL=1.15 Plate DOL=1.15); Is=1.0; Rough Cat B; Fully Exp.; Ce=0.9; Cs=1.00; Ct=1.10
- Unbalanced snow loads have been considered for this design.
- This truss has been designed for greater of min roof live load of 12.0 psf or 1.00 times flat roof load of 20.0 psf on overhangs non-concurrent with other live loads.
- Provide adequate drainage to prevent water ponding.
- This truss has been designed for a 10.0 psf bottom chord live load nonconcurrent with any other live loads.
- * This truss has been designed for a live load of 20.0psf on the bottom chord in all areas where a rectangle 3-06-00 tall by 2-00-00 wide will fit between the bottom chord and any other members.
- One H2.5A Simpson Strong-Tie connectors recommended to connect truss to bearing walls due to UPLIFT at jt(s) 2 and 9. This connection is for uplift only and does not consider lateral forces.
- This truss is designed in accordance with the 2018 International Residential Code sections R502.11.1 and R802.10.2 and referenced standard ANSI/TPI 1.
- Graphical purlin representation does not depict the size or the orientation of the purlin along the top and/or bottom chord.

LOAD CASE(S) Standard



April 1, 2024

WARNING - Verify design parameters and READ NOTES ON THIS AND INCLUDED MITEK REFERENCE PAGE MII-7473 rev. 1/2/2023 BEFORE USE.

Design valid for use only with MITek® connectors. This design is based only upon parameters shown, and is for an individual building component, not a truss system. Before use, the building designer must verify the applicability of design parameters and properly incorporate this design into the overall building design. Bracing indicated is to prevent buckling of individual truss web and/or chord members only. Additional temporary and permanent bracing is always required for stability and to prevent collapse with possible personal injury and property damage. For general guidance regarding the fabrication, storage, delivery, erection and bracing of trusses and truss systems, see ANSI/TPI Quality Criteria and DSB-22 available from Truss Plate Institute (www.tpinst.org) and BCSI Building Component Safety Information available from the Structural Building Component Association (www.sbcacomponents.com)



818 Soundside Road
 Edenton, NC 27932

Job 24030153-01	Truss B5GR	Truss Type Roof Special Girder	Qty 1	Ply 2	142 Serenity-Roof-B329 B LH CP Job Reference (optional)	164576263
--------------------	---------------	-----------------------------------	----------	----------	--	-----------

Carter Components (Sanford, NC), Sanford, NC - 27332,

Run: 9.03 S 8.73 Mar 21 2024 Print: 8.730 S Mar 21 2024 MiTek Industries, Inc. Fri Mar 29 10:41:40
ID: BbQTIaY1ODof8sM?JaCfV5zMCN4-RfC?PsB70Hq3NSgPqnL8w3ulTXbGKWRCDoi7J4zJC?f

Page: 1

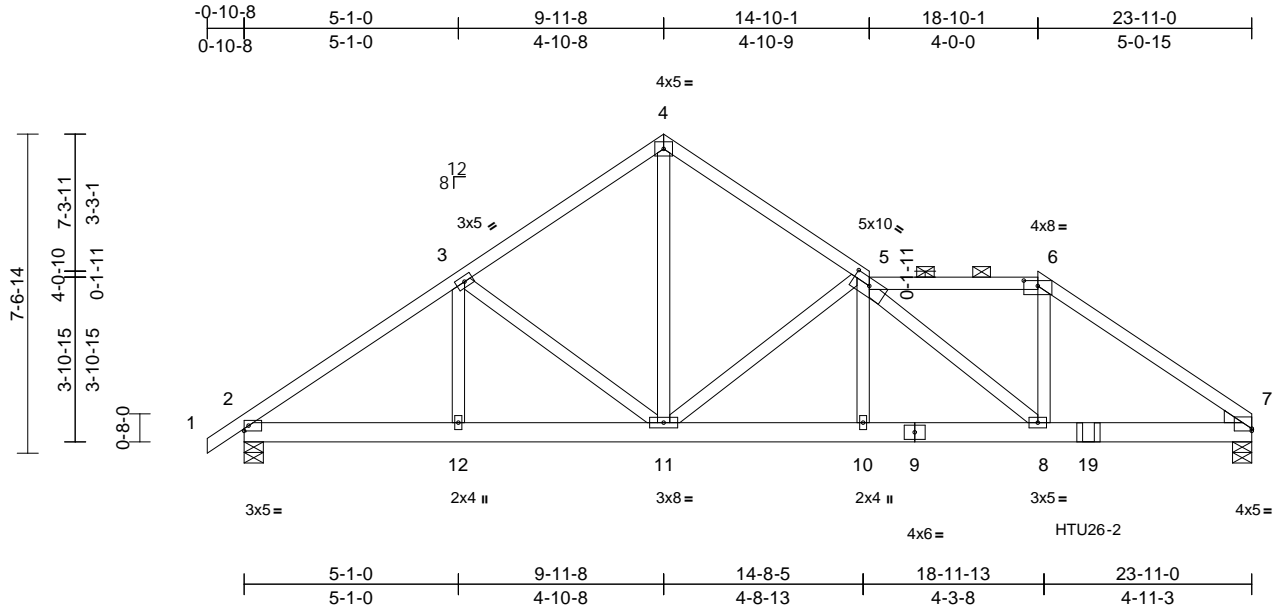

Scale = 1:54.7

Plate Offsets (X, Y): [5:0-5-0,0-2-2], [6:0-4-0,0-1-9], [7:Edge,0-0-10]

Loading	(psf)	Spacing	2-0-0	CSI	DEFL	in	(loc)	l/defl	L/d	PLATES	GRIP	
TCLL (roof)	20.0	Plate Grip DOL	1.15	TC	0.36	Vert(LL)	-0.04	10-11	>999	240	MT20	244/190
Snow (Pf)	20.0	Lumber DOL	1.15	BC	0.55	Vert(CT)	-0.08	10-11	>999	180		
TCDL	10.0	Rep Stress Incr	NO	WB	0.26	Horz(CT)	0.02	7	n/a	n/a		
BCLL	0.0*	Code	IRC2018/TPI2014	Matrix-MSH								
BCDL	10.0											
											Weight: 299 lb	FT = 20%

LUMBER
TOP CHORD 2x4 SP No.2
BOT CHORD 2x6 SP No.2
WEBS 2x4 SP No.3
WEDGE Right: 2x4 SP No.3

BRACING
TOP CHORD Structural wood sheathing directly applied or 6-0-0 oc purlins, except 2-0-0 oc purlins (6-0-0 max.): 5-6.
BOT CHORD Rigid ceiling directly applied or 10-0-0 oc bracing.

REACTIONS (size) 2=0-5-8, 7=0-5-8
Max Horiz 2=165 (LC 9)
Max Uplift 2=-114 (LC 12), 7=-231 (LC 13)
Max Grav 2=1271 (LC 40), 7=1936 (LC 39)

FORCES (lb) - Maximum Compression/Maximum Tension
TOP CHORD 1-2=0/29, 2-3=-1795/150, 3-4=-1509/209, 4-5=-1468/184, 5-6=-2120/319, 6-7=-2684/336
BOT CHORD 2-12=-175/1431, 11-12=-155/1431, 10-11=-161/2325, 8-10=-164/2327, 7-8=-200/2168
WEBS 3-12=0/145, 3-11=-379/166, 4-11=-115/1213, 5-11=-1521/260, 5-10=-54/89, 5-8=-275/260, 6-8=-81/1179

NOTES
1) 2-ply truss to be connected together with 10d (0.131"x3") nails as follows:
Top chords connected as follows: 2x4 - 1 row at 0-9-0 oc.
Bottom chords connected as follows: 2x6 - 2 rows staggered at 0-9-0 oc.
Web connected as follows: 2x4 - 1 row at 0-9-0 oc.

- All loads are considered equally applied to all plies, except if noted as front (F) or back (B) face in the LOAD CASE(S) section. Ply to ply connections have been provided to distribute only loads noted as (F) or (B), unless otherwise indicated.
- Unbalanced roof live loads have been considered for this design.
- Wind: ASCE 7-16; Vult=130mph (3-second gust) Vasd=103mph; TCDL=6.0psf; BCDL=6.0psf; h=25ft; Cat II; Exp B; Enclosed; MWFRS (envelope) exterior zone; cantilever left and right exposed; end vertical left and right exposed; Lumber DOL=1.60 plate grip DOL=1.60
- TCLL: ASCE 7-16; Pr=20.0 psf (roof LL: Lum DOL=1.15 Plate DOL=1.15); Pf=20.0 psf (Lum DOL=1.15 Plate DOL=1.15); Is=1.0; Rough Cat B; Fully Exp.; Ce=0.9; Cs=1.00; Ct=1.10
- Unbalanced snow loads have been considered for this design.
- This truss has been designed for greater of min roof live load of 12.0 psf or 1.00 times flat roof load of 20.0 psf on overhangs non-concurrent with other live loads.
- Provide adequate drainage to prevent water ponding.
- This truss has been designed for a 10.0 psf bottom chord live load nonconcurrent with any other live loads.
- * This truss has been designed for a live load of 20.0psf on the bottom chord in all areas where a rectangle 3-06-00 tall by 2-00-00 wide will fit between the bottom chord and any other members.
- LGT2 Simpson Strong-Tie connectors recommended to connect truss to bearing walls due to UPLIFT at jt(s) 7 and 2. This connection is for uplift only and does not consider lateral forces.
- This truss is designed in accordance with the 2018 International Residential Code sections R502.11.1 and R802.10.2 and referenced standard ANSI/TPI 1.

- Graphical purlin representation does not depict the size or the orientation of the purlin along the top and/or bottom chord.
 - Use Simpson Strong-Tie HTU26-2 (20-10d Girder, 14-10d Truss, Single Ply Girder) or equivalent at 20-0-8 from the left end to connect truss(es) to front face of bottom chord.
 - Fill all nail holes where hanger is in contact with lumber.
 - LGT2 Hurricane ties must have two studs in line below the truss.
- LOAD CASE(S)** Standard
- Dead + Snow (balanced): Lumber Increase=1.15, Plate Increase=1.15
Uniform Loads (lb/ft)
Vert: 1-4=-60, 4-5=-60, 5-6=-60, 6-7=-60, 13-16=-20
Concentrated Loads (lb)
Vert: 19=-1056 (F)



April 1, 2024

WARNING - Verify design parameters and READ NOTES ON THIS AND INCLUDED MITEK REFERENCE PAGE MII-7473 rev. 1/2/2023 BEFORE USE.

Design valid for use only with MiTek® connectors. This design is based only upon parameters shown, and is for an individual building component, not a truss system. Before use, the building designer must verify the applicability of design parameters and properly incorporate this design into the overall building design. Bracing indicated is to prevent buckling of individual truss web and/or chord members only. Additional temporary and permanent bracing is always required for stability and to prevent collapse with possible personal injury and property damage. For general guidance regarding the fabrication, storage, delivery, erection and bracing of trusses and truss systems, see **ANSI/TPI Quality Criteria and DSB-22** available from Truss Plate Institute (www.tpinst.org) and **BCSI Building Component Safety Information** available from the Structural Building Component Association (www.sbcacomponents.com)

ENGINEERING BY
TRENCO
A MiTek Affiliate

818 Soundside Road
Edenton, NC 27932

Job 24030153-01	Truss D1A	Truss Type Common	Qty 2	Ply 1	142 Serenity-Roof-B329 B LH CP Job Reference (optional)	164576264
--------------------	--------------	----------------------	----------	----------	--	-----------

Carter Components (Sanford, NC), Sanford, NC - 27332,

Run: 9.03 S 8.73 Mar 21 2024 Print: 8.730 S Mar 21 2024 MiTek Industries, Inc. Fri Mar 29 10:41:41

Page: 1

Id:CsyuH_9hORxEgU9Gof?ehgzMCMp-RfC?PsB70Hq3NSgPqnL8w3uITXbGKWrCDoi7J4zJC?f

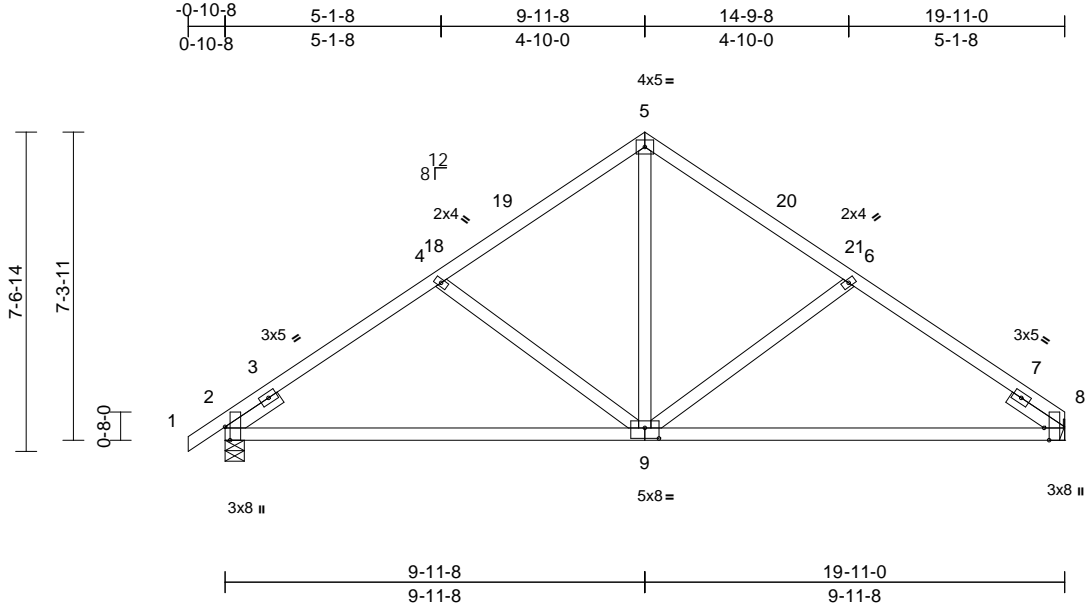

Scale = 1:54.7

Plate Offsets (X, Y): [2:0-3-13,Edge], [8:0-3-8,Edge], [9:0-4-0,0-3-0]

Loading	(psf)	Spacing	2-0-0	CSI	DEFL	in	(loc)	l/defl	L/d	PLATES	GRIP	
TCLL (roof)	20.0	Plate Grip DOL	1.15	TC	0.51	Vert(LL)	-0.13	9-12	>999	240	MT20	244/190
Snow (Pf)	20.0	Lumber DOL	1.15	BC	0.83	Vert(CT)	-0.28	9-12	>868	180		
TCDL	10.0	Rep Stress Incr	YES	WB	0.27	Horz(CT)	0.02	8	n/a	n/a		
BCLL	0.0*	Code	IRC2018/TPI2014	Matrix-MSH								
BCDL	10.0											
											Weight: 99 lb	FT = 20%

LUMBER

TOP CHORD 2x4 SP No.2
 BOT CHORD 2x4 SP No.2
 WEBS 2x4 SP No.3
 SLIDER Left 2x4 SP No.3 -- 1-6-0, Right 2x4 SP No.3 -- 1-6-0

BRACING

TOP CHORD Structural wood sheathing directly applied or 5-4-1 oc purlins.
 BOT CHORD Rigid ceiling directly applied or 10-0-0 oc bracing.

REACTIONS

(size) 2=0-5-8, 8= Mechanical
 Max Horiz 2=165 (LC 13)
 Max Uplift 2=-85 (LC 14), 8=-67 (LC 15)
 Max Grav 2=897 (LC 21), 8=843 (LC 22)

FORCES

(lb) - Maximum Compression/Maximum Tension
 TOP CHORD 1-2=0/29, 2-4=-1007/148, 4-5=-876/139, 5-6=-877/139, 6-8=-1010/149
 BOT CHORD 2-8=-200/903
 WEBS 5-9=-31/595, 6-9=-370/184, 4-9=-366/183

NOTES

- 1) Unbalanced roof live loads have been considered for this design.
- 2) Wind: ASCE 7-16; Vult=130mph (3-second gust) Vasd=103mph; TCDL=6.0psf; BCDL=6.0psf; h=25ft; Cat. II; Exp B; Enclosed; MWFRS (envelope) exterior zone and C-C Exterior(2E) -0-10-8 to 2-1-8, Interior (1) 2-1-8 to 6-11-8, Exterior(2R) 6-11-8 to 12-11-8, Interior (1) 12-11-8 to 16-11-0, Exterior(2E) 16-11-0 to 19-11-0 zone; cantilever left and right exposed; end vertical left and right exposed; C-C for members and forces & MWFRS for reactions shown; Lumber DOL=1.60 plate grip DOL=1.60

- 3) TCLL: ASCE 7-16; Pr=20.0 psf (roof LL: Lum DOL=1.15 Plate DOL=1.15); Pf=20.0 psf (Lum DOL=1.15 Plate DOL=1.15); Is=1.0; Rough Cat B; Fully Exp.; Ce=0.9; Cs=1.00; Ct=1.10
- 4) Unbalanced snow loads have been considered for this design.
- 5) This truss has been designed for greater of min roof live load of 12.0 psf or 1.00 times flat roof load of 20.0 psf on overhangs non-concurrent with other live loads.
- 6) This truss has been designed for a 10.0 psf bottom chord live load nonconcurrent with any other live loads.
- 7) * This truss has been designed for a live load of 20.0psf on the bottom chord in all areas where a rectangle 3-06-00 tall by 2-00-00 wide will fit between the bottom chord and any other members.
- 8) Refer to girder(s) for truss connections.
- 9) Provide mechanical connection (by others) of truss to bearing plate capable of withstanding 67 lb uplift at joint 8.
- 10) One H2.5A Simpson Strong-Tie connectors recommended to connect truss to bearing walls due to UPLIFT at jt(s) 2. This connection is for uplift only and does not consider lateral forces.
- 11) This truss is designed in accordance with the 2018 International Residential Code sections R502.11.1 and R802.10.2 and referenced standard ANSI/TPI 1.

LOAD CASE(S) Standard



April 1, 2024

WARNING - Verify design parameters and READ NOTES ON THIS AND INCLUDED MITEK REFERENCE PAGE MII-7473 rev. 1/2/2023 BEFORE USE.

Design valid for use only with MiTek® connectors. This design is based only upon parameters shown, and is for an individual building component, not a truss system. Before use, the building designer must verify the applicability of design parameters and properly incorporate this design into the overall building design. Bracing indicated is to prevent buckling of individual truss web and/or chord members only. Additional temporary and permanent bracing is always required for stability and to prevent collapse with possible personal injury and property damage. For general guidance regarding the fabrication, storage, delivery, erection and bracing of trusses and truss systems, see **ANSI/TPI Quality Criteria and DSB-22** available from Truss Plate Institute (www.tpinst.org) and **BCSI Building Component Safety Information** available from the Structural Building Component Association (www.sbcacomponents.com)



818 Soundside Road
 Edenton, NC 27932

Job 24030153-01	Truss HGE	Truss Type Common Supported Gable	Qty 1	Ply 1	142 Serenity-Roof-B329 B LH CP Job Reference (optional)	164576265
--------------------	--------------	--------------------------------------	----------	----------	--	-----------

Carter Components (Sanford, NC), Sanford, NC - 27332,

Run: 9.03 S 8.73 Mar 21 2024 Print: 8.730 S Mar 21 2024 MiTek Industries, Inc. Fri Mar 29 10:41:42

Page: 1

ID:4Z51CcRpxX4FZrkeSa9c43zMDE_-RFC?PsB70Hq3NSgPqnL8w3uITXbGKwRcDoi7J4zJC?f

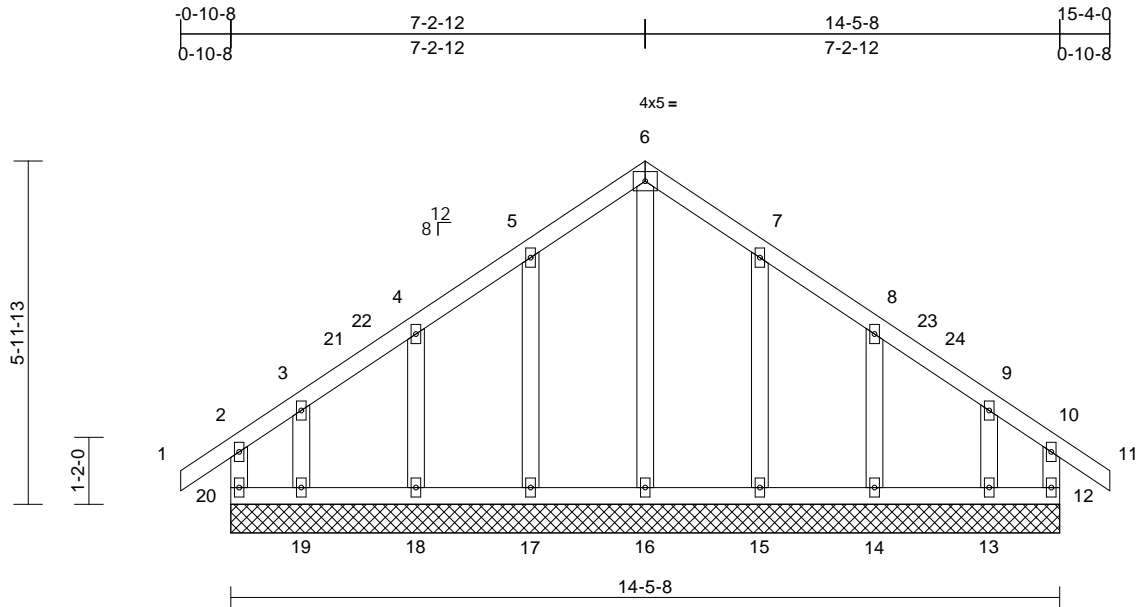

Scale = 1:40.2

Loading	(psf)	Spacing	2-0-0	CSI	DEFL	in	(loc)	l/defl	L/d	PLATES	GRIP	
TCLL (roof)	20.0	Plate Grip DOL	1.15	TC	0.13	Vert(LL)	n/a	-	n/a	999	MT20	244/190
Snow (Pf)	20.0	Lumber DOL	1.15	BC	0.06	Vert(CT)	n/a	-	n/a	999		
TCDL	10.0	Rep Stress Incr	YES	WB	0.12	Horz(CT)	0.00	12	n/a	n/a		
BCLL	0.0*	Code	IRC2018/TPI2014	Matrix-MR								
BCDL	10.0											
											Weight: 86 lb	FT = 20%

LUMBER
TOP CHORD 2x4 SP No.2
BOT CHORD 2x4 SP No.2
WEBS 2x4 SP No.3
OTHERS 2x4 SP No.3

BRACING
TOP CHORD Structural wood sheathing directly applied or 6-0-0 oc purlins, except end verticals.
BOT CHORD Rigid ceiling directly applied or 6-0-0 oc bracing.

REACTIONS (size)
12=14-5-8, 13=14-5-8, 14=14-5-8, 15=14-5-8, 16=14-5-8, 17=14-5-8, 18=14-5-8, 19=14-5-8, 20=14-5-8
Max Horiz 20=159 (LC 12)
Max Uplift 12=75 (LC 11), 13=92 (LC 15), 14=56 (LC 15), 15=59 (LC 15), 17=59 (LC 14), 18=55 (LC 14), 19=98 (LC 14), 20=96 (LC 10)
Max Grav 12=142 (LC 25), 13=171 (LC 26), 14=229 (LC 22), 15=259 (LC 22), 16=180 (LC 28), 17=259 (LC 21), 18=229 (LC 21), 19=182 (LC 25), 20=159 (LC 26)

FORCES (lb) - Maximum Compression/Maximum Tension
TOP CHORD 2-20=-124/107, 1-2=0/34, 2-3=-97/98, 3-4=-64/94, 4-5=-60/172, 5-6=-96/241, 6-7=-96/241, 7-8=-60/172, 8-9=-52/95, 9-10=-77/80, 10-11=0/34, 10-12=-112/91
BOT CHORD 19-20=-78/90, 18-19=-78/90, 17-18=-78/90, 16-17=-78/90, 15-16=-78/90, 14-15=-78/90, 13-14=-78/90, 12-13=-78/90
WEBS 6-16=-192/16, 5-17=-219/101, 4-18=-188/116, 3-19=-123/89, 7-15=-219/101, 8-14=-188/115, 9-13=-112/100

NOTES

- Unbalanced roof live loads have been considered for this design.
- Wind: ASCE 7-16; Vult=130mph (3-second gust) Vasd=103mph; TC DL=6.0psf; BCDL=6.0psf; h=25ft; Cat. II; Exp B; Enclosed; MWFRS (envelope) exterior zone and C-C Corner(3E) -0-10-8 to 2-1-8, Exterior(2N) 2-1-8 to 4-2-12, Corner(3R) 4-2-12 to 10-2-12, Exterior(2N) 10-2-12 to 12-4-0, Corner(3E) 12-4-0 to 15-4-0 zone; cantilever left and right exposed; end vertical left and right exposed; C-C for members and forces & MWFRS for reactions shown; Lumber DOL=1.60 plate grip DOL=1.60
- Truss designed for wind loads in the plane of the truss only. For studs exposed to wind (normal to the face), see Standard Industry Gable End Details as applicable, or consult qualified building designer as per ANSI/TPI 1.
- TCLL: ASCE 7-16; Pr=20.0 psf (roof LL: Lum DOL=1.15 Plate DOL=1.15); Pf=20.0 psf (Lum DOL=1.15 Plate DOL=1.15); Is=1.0; Rough Cat B; Fully Exp.; Ce=0.9; Cs=1.00; Ct=1.10
- Unbalanced snow loads have been considered for this design.
- This truss has been designed for greater of min roof live load of 12.0 psf or 1.00 times flat roof load of 20.0 psf on overhangs non-concurrent with other live loads.
- All plates are 2x4 MT20 unless otherwise indicated.
- Gable requires continuous bottom chord bearing.
- Truss to be fully sheathed from one face or securely braced against lateral movement (i.e. diagonal web).
- Gable studs spaced at 2-0-0 oc.
- This truss has been designed for a 10.0 psf bottom chord live load nonconcurrent with any other live loads.
- * This truss has been designed for a live load of 20.0psf on the bottom chord in all areas where a rectangle 3-06-00 tall by 2-00-00 wide will fit between the bottom chord and any other members.

- Provide mechanical connection (by others) of truss to bearing plate capable of withstanding 96 lb uplift at joint 20, 75 lb uplift at joint 12, 59 lb uplift at joint 17, 55 lb uplift at joint 18, 98 lb uplift at joint 19, 59 lb uplift at joint 15, 56 lb uplift at joint 14 and 92 lb uplift at joint 13.
 - This truss is designed in accordance with the 2018 International Residential Code sections R502.11.1 and R802.10.2 and referenced standard ANSI/TPI 1.
- LOAD CASE(S)** Standard



April 1, 2024

WARNING - Verify design parameters and READ NOTES ON THIS AND INCLUDED MITEK REFERENCE PAGE MII-7473 rev. 1/2/2023 BEFORE USE.

Design valid for use only with MiTek® connectors. This design is based only upon parameters shown, and is for an individual building component, not a truss system. Before use, the building designer must verify the applicability of design parameters and properly incorporate this design into the overall building design. Bracing indicated is to prevent buckling of individual truss web and/or chord members only. Additional temporary and permanent bracing is always required for stability and to prevent collapse with possible personal injury and property damage. For general guidance regarding the fabrication, storage, delivery, erection and bracing of trusses and truss systems, see **ANSI/TPI Quality Criteria and DSB-22** available from Truss Plate Institute (www.tpinst.org) and **BCSI Building Component Safety Information** available from the Structural Building Component Association (www.sbcacomponents.com)

ENGINEERING BY
TRENCO
A MiTek Affiliate

818 Soundside Road
Edenton, NC 27932

Job 24030153-01	Truss H	Truss Type Common	Qty 5	Ply 1	142 Serenity-Roof-B329 B LH CP Job Reference (optional)	I64576266
--------------------	------------	----------------------	----------	----------	--	-----------

Carter Components (Sanford, NC), Sanford, NC - 27332,

Run: 9.03 S 8.73 Mar 21 2024 Print: 8.730 S Mar 21 2024 MiTek Industries, Inc. Fri Mar 29 10:41:42

Page: 1

ID:bfGOJ8MZD?XWYZ9mx9bVf?zMDGf-RfC?PsB70Hq3NSgPqnL8w3uITXbGKwRCDoi7J4zJC?f

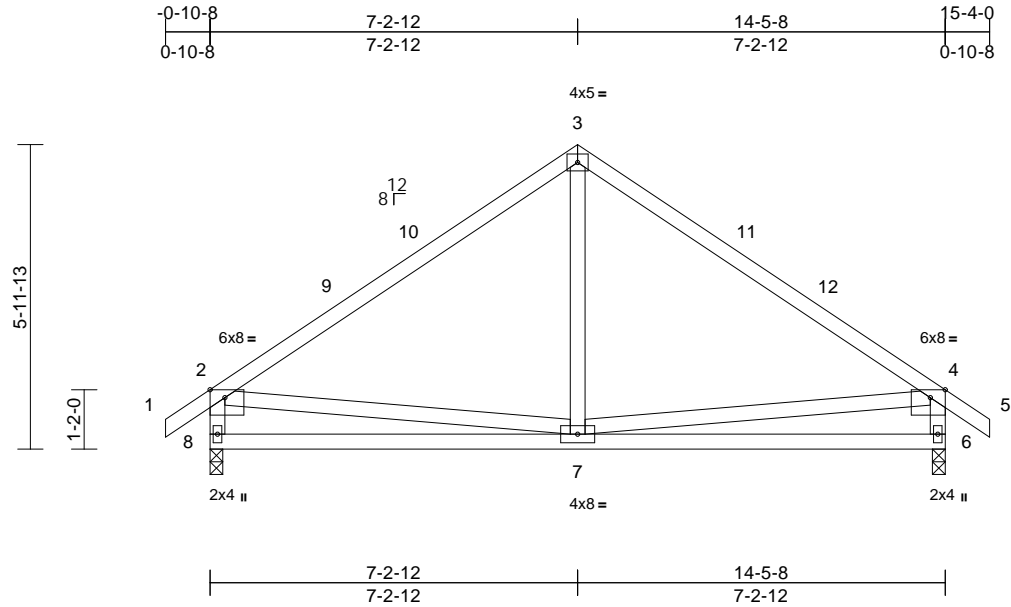

Scale = 1:45.3

Plate Offsets (X, Y): [2:0-3-8,Edge], [4:0-3-8,Edge]

Loading	(psf)	Spacing	2-0-0	CSI	DEFL	in	(loc)	l/defl	L/d	PLATES	GRIP	
TCLL (roof)	20.0	Plate Grip DOL	1.15	TC	0.93	Vert(LL)	-0.05	7-8	>999	240	MT20	244/190
Snow (Pf)	20.0	Lumber DOL	1.15	BC	0.45	Vert(CT)	-0.10	7-8	>999	180		
TCDL	10.0	Rep Stress Incr	YES	WB	0.14	Horz(CT)	0.01	6	n/a	n/a		
BCLL	0.0*	Code	IRC2018/TPI2014	Matrix-MSH								
BCDL	10.0											
											Weight: 81 lb	FT = 20%

LUMBER

TOP CHORD 2x4 SP No.2
 BOT CHORD 2x4 SP No.2
 WEBS 2x4 SP No.3 *Except* 8-2,6-4:2x4 SP No.2

BRACING

TOP CHORD Structural wood sheathing directly applied or 2-2-0 oc purlins, except end verticals.
 BOT CHORD Rigid ceiling directly applied or 10-0-0 oc bracing.

REACTIONS

(size) 6=0-3-0, 8=0-3-0
 Max Horiz 8=-159 (LC 12)
 Max Uplift 6=-65 (LC 15), 8=-65 (LC 14)
 Max Grav 6=705 (LC 22), 8=705 (LC 21)

FORCES

(lb) - Maximum Compression/Maximum Tension
 TOP CHORD 1-2=0/34, 2-3=-666/278, 3-4=-666/278,
 4-5=0/34, 2-8=-642/258, 4-6=-642/254
 BOT CHORD 7-8=-234/435, 6-7=-157/435
 WEBS 3-7=-125/283, 2-7=-138/267, 4-7=-143/267

NOTES

- Unbalanced roof live loads have been considered for this design.
- Wind: ASCE 7-16; Vult=130mph (3-second gust)
 Vasd=103mph; TCDL=6.0psf; BCDL=6.0psf; h=25ft; Cat. II; Exp B; Enclosed; MWFRS (envelope) exterior zone and C-C Exterior(2E) 0-10-8 to 2-1-8, Interior (1) 2-1-8 to 4-2-12, Exterior(2R) 4-2-12 to 10-2-12, Interior (1) 10-2-12 to 12-4-0, Exterior(2E) 12-4-0 to 15-4-0 zone; cantilever left and right exposed; end vertical left and right exposed; porch left and right exposed; C-C for members and forces & MWFRS for reactions shown; Lumber DOL=1.60 plate grip DOL=1.60
- TCLL: ASCE 7-16; Pr=20.0 psf (roof LL: Lum DOL=1.15 Plate DOL=1.15); Pf=20.0 psf (Lum DOL=1.15 Plate DOL=1.15); Is=1.0; Rough Cat B; Fully Exp.; Ce=0.9; Cs=1.00; Ct=1.10

- Unbalanced snow loads have been considered for this design.
- This truss has been designed for greater of min roof live load of 12.0 psf or 1.00 times flat roof load of 20.0 psf on overhangs non-concurrent with other live loads.
- This truss has been designed for a 10.0 psf bottom chord live load nonconcurrent with any other live loads.
- * This truss has been designed for a live load of 20.0psf on the bottom chord in all areas where a rectangle 3-06-00 tall by 2-00-00 wide will fit between the bottom chord and any other members.
- One H2.5A Simpson Strong-Tie connectors recommended to connect truss to bearing walls due to UPLIFT at jt(s) 8 and 6. This connection is for uplift only and does not consider lateral forces.
- This truss is designed in accordance with the 2018 International Residential Code sections R502.11.1 and R802.10.2 and referenced standard ANSI/TPI 1.

LOAD CASE(S) Standard

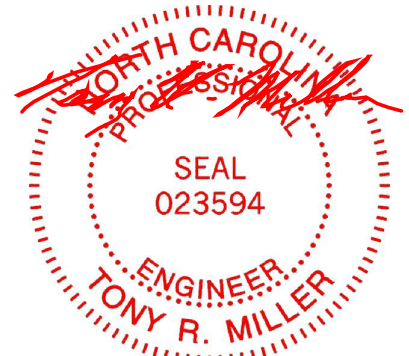

April 1, 2024

WARNING - Verify design parameters and READ NOTES ON THIS AND INCLUDED MITEK REFERENCE PAGE MII-7473 rev. 1/2/2023 BEFORE USE.

Design valid for use only with MiTek® connectors. This design is based only upon parameters shown, and is for an individual building component, not a truss system. Before use, the building designer must verify the applicability of design parameters and properly incorporate this design into the overall building design. Bracing indicated is to prevent buckling of individual truss web and/or chord members only. Additional temporary and permanent bracing is always required for stability and to prevent collapse with possible personal injury and property damage. For general guidance regarding the fabrication, storage, delivery, erection and bracing of trusses and truss systems, see **ANSI/TPH Quality Criteria and DSB-22** available from Truss Plate Institute (www.tpinst.org) and **BCSI Building Component Safety Information** available from the Structural Building Component Association (www.sbcacomponents.com)



818 Soundside Road
 Edenton, NC 27932

Job 24030153-01	Truss EGR	Truss Type Common Girder	Qty 1	Ply 2	142 Serenity-Roof-B329 B LH CP Job Reference (optional)	164576267
--------------------	--------------	-----------------------------	----------	----------	--	-----------

Carter Components (Sanford, NC), Sanford, NC - 27332,

Run: 9.03 S 8.73 Mar 21 2024 Print: 8.730 S Mar 21 2024 MITek Industries, Inc. Fri Mar 29 10:41:41
ID:Ws_ekb?PSj8j0DmtCOLcX6zMBu1-RFC?PsB70Hq3NSGpqnL8w3uITXbGKwRCDoi7J4zJC?

Page: 1

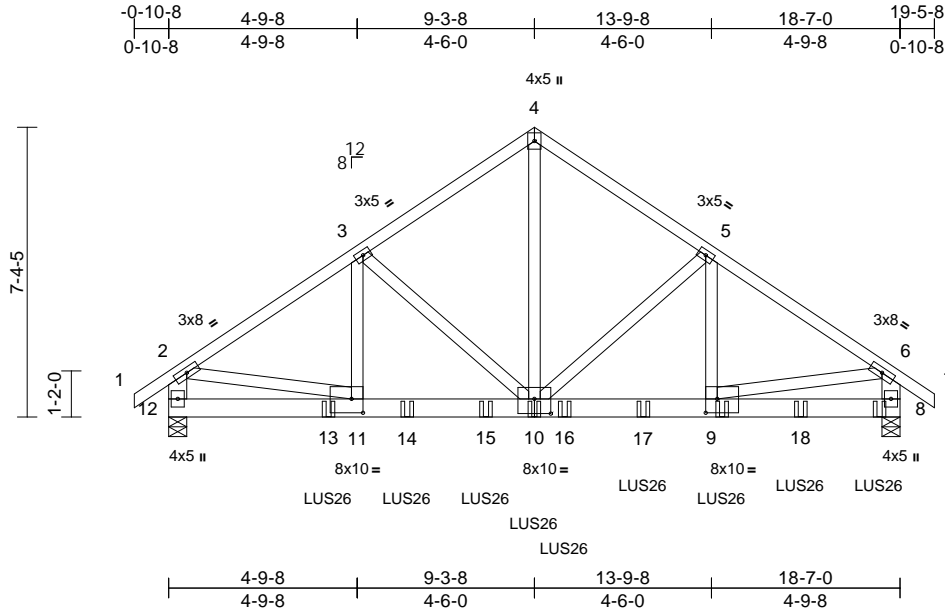

Scale = 1:58.5

Plate Offsets (X, Y): [9:0-3-8,0-4-4], [10:0-5-0,0-4-8], [11:0-3-8,0-4-4]

Loading	(psf)	Spacing	2-0-0	CSI	DEFL	in	(loc)	l/defl	L/d	PLATES	GRIP	
TCLL (roof)	20.0	Plate Grip DOL	1.15	TC	0.38	Vert(LL)	-0.07	10-11	>999	240	MT20	244/190
Snow (Pf)	20.0	Lumber DOL	1.15	BC	0.75	Vert(CT)	-0.12	10-11	>999	180		
TCDL	10.0	Rep Stress Incr	NO	WB	0.78	Horz(CT)	0.02	8	n/a	n/a		
BCLL	0.0*	Code	IRC2018/TPI2014	Matrix-MSH								
BCDL	10.0											
											Weight: 266 lb	FT = 20%

LUMBER
TOP CHORD 2x4 SP No.2
BOT CHORD 2x6 SP No.2
WEBS 2x4 SP No.3 *Except* 12-2,8-6:2x6 SP No.2

BRACING
TOP CHORD Structural wood sheathing directly applied or 5-7-0 oc purlins, except end verticals.
BOT CHORD Rigid ceiling directly applied or 10-0-0 oc bracing.

REACTIONS (size) 8=0-5-8, 12=0-5-8
Max Horiz 12=191 (LC 11)
Max Uplift 8=-688 (LC 13), 12=-619 (LC 12)
Max Grav 8=4392 (LC 20), 12=3720 (LC 19)

FORCES (lb) - Maximum Compression/Maximum Tension
TOP CHORD 1-2=0/37, 2-3=-4819/802, 3-4=-3792/665, 4-5=-3792/665, 5-6=-4604/724, 6-7=0/37, 2-12=-3549/612, 6-8=-3370/553
BOT CHORD 11-12=-226/571, 9-11=-666/3940, 8-9=-112/556
WEBS 4-10=-638/3766, 5-10=-999/243, 5-9=-115/918, 3-10=-1185/329, 3-11=-216/1060, 2-11=-520/3585, 6-9=-450/3290

NOTES
1) 2-ply truss to be connected together with 10d (0.131"x3") nails as follows:
Top chords connected as follows: 2x4 - 1 row at 0-9-0 oc, 2x6 - 2 rows staggered at 0-9-0 oc.
Bottom chords connected as follows: 2x6 - 2 rows staggered at 0-9-0 oc.
Web connected as follows: 2x4 - 1 row at 0-9-0 oc.
2) All loads are considered equally applied to all plies, except if noted as front (F) or back (B) face in the LOAD CASE(S) section. Ply to ply connections have been provided to distribute only loads noted as (F) or (B), unless otherwise indicated.

- Unbalanced roof live loads have been considered for this design.
- Wind: ASCE 7-16; Vult=130mph (3-second gust) Vasd=103mph; TCDL=6.0psf; BCDL=6.0psf; h=25ft; Cat II; Exp B; Enclosed; MWFRS (envelope) exterior zone; cantilever left and right exposed; end vertical left and right exposed; Lumber DOL=1.60 plate grip DOL=1.60
- TCLL: ASCE 7-16; Pr=20.0 psf (roof LL: Lum DOL=1.15 Plate DOL=1.15); Pf=20.0 psf (Lum DOL=1.15 Plate DOL=1.15); Is=1.0; Rough Cat B; Fully Exp.; Ce=0.9; Cs=1.00; Ct=1.10
- Unbalanced snow loads have been considered for this design.
- This truss has been designed for greater of min roof live load of 12.0 psf or 1.00 times flat roof load of 20.0 psf on overhangs non-concurrent with other live loads.
- This truss has been designed for a 10.0 psf bottom chord live load nonconcurrent with any other live loads.
- * This truss has been designed for a live load of 20.0psf on the bottom chord in all areas where a rectangle 3-06-00 tall by 2-00-00 wide will fit between the bottom chord and any other members.
- LGT2 Simpson Strong-Tie connectors recommended to connect truss to bearing walls due to UPLIFT at jt(s) 12 and 8. This connection is for uplift only and does not consider lateral forces.
- This truss is designed in accordance with the 2018 International Residential Code sections R502.11.1 and R802.10.2 and referenced standard ANSI/TPI 1.
- Use Simpson Strong-Tie LUS26 (4-10d Girder, 4-10d Truss) or equivalent at 4-0-12 from the left end to connect truss(es) to back face of bottom chord.
- Use Simpson Strong-Tie LUS26 (4-10d Girder, 3-10d Truss, Single Ply Girder) or equivalent spaced at 2-0-0 oc max. starting at 6-0-12 from the left end to 18-0-12 to connect truss(es) to back face of bottom chord.
- Fill all nail holes where hanger is in contact with lumber.

- LGT2 Hurricane ties must have two studs in line below the truss.
 - Hanger(s) or other connection device(s) shall be provided sufficient to support concentrated load(s) 657 lb down and 104 lb up at 18-4-4 on bottom chord. The design/selection of such connection device(s) is the responsibility of others.
- LOAD CASE(S)** Standard
- Dead + Snow (balanced): Lumber Increase=1.15, Plate Increase=1.15
Uniform Loads (lb/ft)
Vert: 1-2=-60, 2-4=-60, 4-6=-60, 6-7=-60, 8-12=-20
Concentrated Loads (lb)
Vert: 10=-630 (B), 9=-628 (B), 8=-638 (B), 13=-1038 (B), 14=-803 (B), 15=-801 (B), 16=-628 (B), 17=-628 (B), 18=-631 (B)

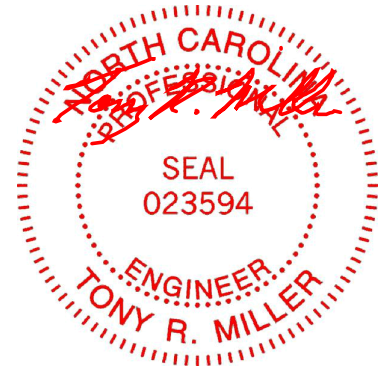

April 1, 2024

WARNING - Verify design parameters and READ NOTES ON THIS AND INCLUDED MITEK REFERENCE PAGE MII-7473 rev. 1/2/2023 BEFORE USE.

Design valid for use only with MITek® connectors. This design is based only upon parameters shown, and is for an individual building component, not a truss system. Before use, the building designer must verify the applicability of design parameters and properly incorporate this design into the overall building design. Bracing indicated is to prevent buckling of individual truss web and/or chord members only. Additional temporary and permanent bracing is always required for stability and to prevent collapse with possible personal injury and property damage. For general guidance regarding the fabrication, storage, delivery, erection and bracing of trusses and truss systems, see **ANSI/TPI Quality Criteria and DSB-22** available from Truss Plate Institute (www.tpinst.org) and **BCSI Building Component Safety Information** available from the Structural Building Component Association (www.sbcacomponents.com)



818 Soundside Road
Edenton, NC 27932

Job 24030153-01	Truss EGE	Truss Type Common Supported Gable	Qty 1	Ply 1	142 Serenity-Roof-B329 B LH CP Job Reference (optional)	I64576268
--------------------	--------------	--------------------------------------	----------	----------	--	-----------

Carter Components (Sanford, NC), Sanford, NC - 27332,

Run: 9.03 S 8.73 Mar 21 2024 Print: 8.730 S Mar 21 2024 MITek Industries, Inc. Fri Mar 29 10:41:41

Page: 1

ID: _esNCUIUPIWo4zacA9qaZdzMD57-RfC?PsB70Hq3NSgPqnL8w3ulTXbGKWRCDoi7J4zJC?f

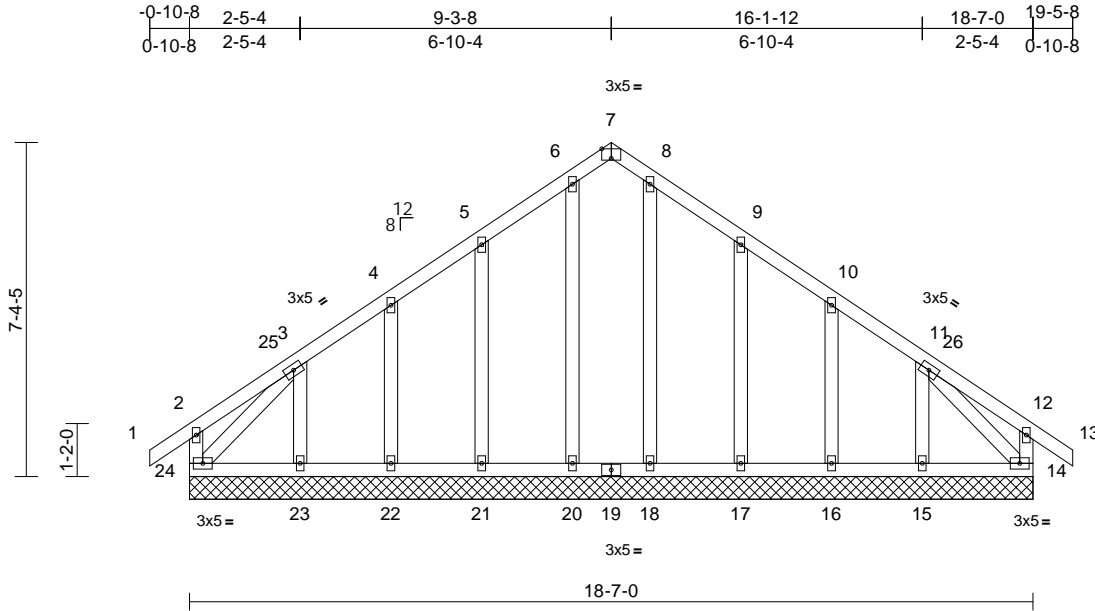

Scale = 1:50.8

Plate Offsets (X, Y): [7:0-2-8,Edge]

Loading	(psf)	Spacing	2-0-0	CSI	DEFL	in	(loc)	l/defl	L/d	PLATES	GRIP	
TCLL (roof)	20.0	Plate Grip DOL	1.15	TC	0.10	Vert(LL)	n/a	-	n/a	999	MT20	244/190
Snow (Pf)	20.0	Lumber DOL	1.15	BC	0.05	Vert(CT)	n/a	-	n/a	999		
TCDL	10.0	Rep Stress Incr	YES	WB	0.13	Horz(CT)	0.00	14	n/a	n/a		
BCLL	0.0*	Code	IRC2018/TPI2014	Matrix-MSH								
BCDL	10.0											
											Weight: 126 lb	FT = 20%

LUMBER
TOP CHORD 2x4 SP No.2
BOT CHORD 2x4 SP No.2
WEBS 2x4 SP No.3
OTHERS 2x4 SP No.3

BRACING
TOP CHORD Structural wood sheathing directly applied or 6-0-0 oc purlins, except end verticals.
BOT CHORD Rigid ceiling directly applied or 10-0-0 oc bracing.

REACTIONS (size)
14=18-7-0, 15=18-7-0, 16=18-7-0, 17=18-7-0, 18=18-7-0, 20=18-7-0, 21=18-7-0, 22=18-7-0, 23=18-7-0, 24=18-7-0
Max Horiz 24=191 (LC 13)
Max Uplift 14=1 (LC 11), 15=120 (LC 15), 16=52 (LC 15), 17=75 (LC 15), 21=72 (LC 14), 22=53 (LC 14), 23=126 (LC 14), 24=39 (LC 10)
Max Grav 14=172 (LC 22), 15=205 (LC 26), 16=195 (LC 22), 17=257 (LC 22), 18=196 (LC 22), 20=196 (LC 21), 21=257 (LC 21), 22=195 (LC 21), 23=217 (LC 25), 24=195 (LC 26)

FORCES (lb) - Maximum Compression/Maximum Tension
TOP CHORD 2-24=-137/124, 1-2=0/34, 2-3=-58/59, 3-4=-104/80, 4-5=-90/70, 5-6=-81/137, 6-7=-70/125, 7-8=-70/125, 8-9=-81/137, 9-10=-74/61, 10-11=-75/35, 11-12=-54/94, 12-13=0/34, 12-14=-139/144
BOT CHORD 23-24=-79/191, 22-23=-79/191, 21-22=-79/191, 20-21=-79/191, 18-20=-79/191, 17-18=-79/191, 16-17=-79/191, 15-16=-79/191, 14-15=-79/191

WEBS
6-20=-160/19, 8-18=-160/0, 5-21=-215/115, 4-22=-158/85, 3-23=-180/152, 9-17=-215/115, 10-16=-158/85, 11-15=-170/165, 3-24=-201/145, 11-14=-203/94

NOTES

- Unbalanced roof live loads have been considered for this design.
- Wind: ASCE 7-16; Vult=130mph (3-second gust) Vasd=103mph; TCDL=6.0psf; BCDL=6.0psf; h=25ft; Cat II; Exp B; Enclosed; MWFRS (envelope) exterior zone and C-C Corner(3E) -0-10-8 to 2-1-8, Exterior(2N) 2-1-8 to 6-3-8, Corner(3R) 6-3-8 to 12-1-12, Exterior(2N) 12-1-12 to 16-5-8, Corner(3E) 16-5-8 to 19-5-8 zone; cantilever left and right exposed; end vertical left and right exposed; C-C for members and forces & MWFRS for reactions shown; Lumber DOL=1.60 plate grip DOL=1.60
- Truss designed for wind loads in the plane of the truss only. For studs exposed to wind (normal to the face), see Standard Industry Gable End Details as applicable, or consult qualified building designer as per ANSI/TPI 1.
- TCLL: ASCE 7-16; Pr=20.0 psf (roof LL: Lum DOL=1.15 Plate DOL=1.15); Pf=20.0 psf (Lum DOL=1.15 Plate DOL=1.15); Is=1.0; Rough Cat B; Fully Exp.; Ce=0.9; Cs=1.00; Ct=1.10
- Unbalanced snow loads have been considered for this design.
- This truss has been designed for greater of min roof live load of 12.0 psf or 1.00 times flat roof load of 20.0 psf on overhangs non-concurrent with other live loads.
- All plates are 2x4 MT20 unless otherwise indicated.
- Gable requires continuous bottom chord bearing.
- Truss to be fully sheathed from one face or securely braced against lateral movement (i.e. diagonal web).
- Gable studs spaced at 2-0-0 oc.
- This truss has been designed for a 10.0 psf bottom chord live load nonconcurrent with any other live loads.

- * This truss has been designed for a live load of 20.0psf on the bottom chord in all areas where a rectangle 3-06-00 tall by 2-00-00 wide will fit between the bottom chord and any other members.
- N/A

- This truss is designed in accordance with the 2018 International Residential Code sections R502.11.1 and R802.10.2 and referenced standard ANSI/TPI 1.

LOAD CASE(S) Standard



April 1, 2024

WARNING - Verify design parameters and READ NOTES ON THIS AND INCLUDED MITEK REFERENCE PAGE MII-7473 rev. 1/2/2023 BEFORE USE.

Design valid for use only with MITek® connectors. This design is based only upon parameters shown, and is for an individual building component, not a truss system. Before use, the building designer must verify the applicability of design parameters and properly incorporate this design into the overall building design. Bracing indicated is to prevent buckling of individual truss web and/or chord members only. Additional temporary and permanent bracing is always required for stability and to prevent collapse with possible personal injury and property damage. For general guidance regarding the fabrication, storage, delivery, erection and bracing of trusses and truss systems, see **ANSI/TPI1 Quality Criteria and DSB-22** available from Truss Plate Institute (www.tpinst.org) and **BCSI Building Component Safety Information** available from the Structural Building Component Association (www.sbcacomponents.com)



818 Soundside Road
Edenton, NC 27932

Job 24030153-01	Truss A4SE	Truss Type Piggyback Base Structural Gable	Qty 1	Ply 1	142 Serenity-Roof-B329 B LH CP Job Reference (optional)	164576269
--------------------	---------------	---	----------	----------	--	-----------

Carter Components (Sanford, NC), Sanford, NC - 27332,

Run: 9.03 S 8.73 Mar 21 2024 Print: 8.730 S Mar 21 2024 MITek Industries, Inc. Fri Mar 29 10:41:36
ID:97jmf?YRCesUy9xFwEmOuvZmC0N-RfC?PsB70Hq3NSgPqnL8w3uTXbGKwRCDoi7J4zJC?f

Page: 1

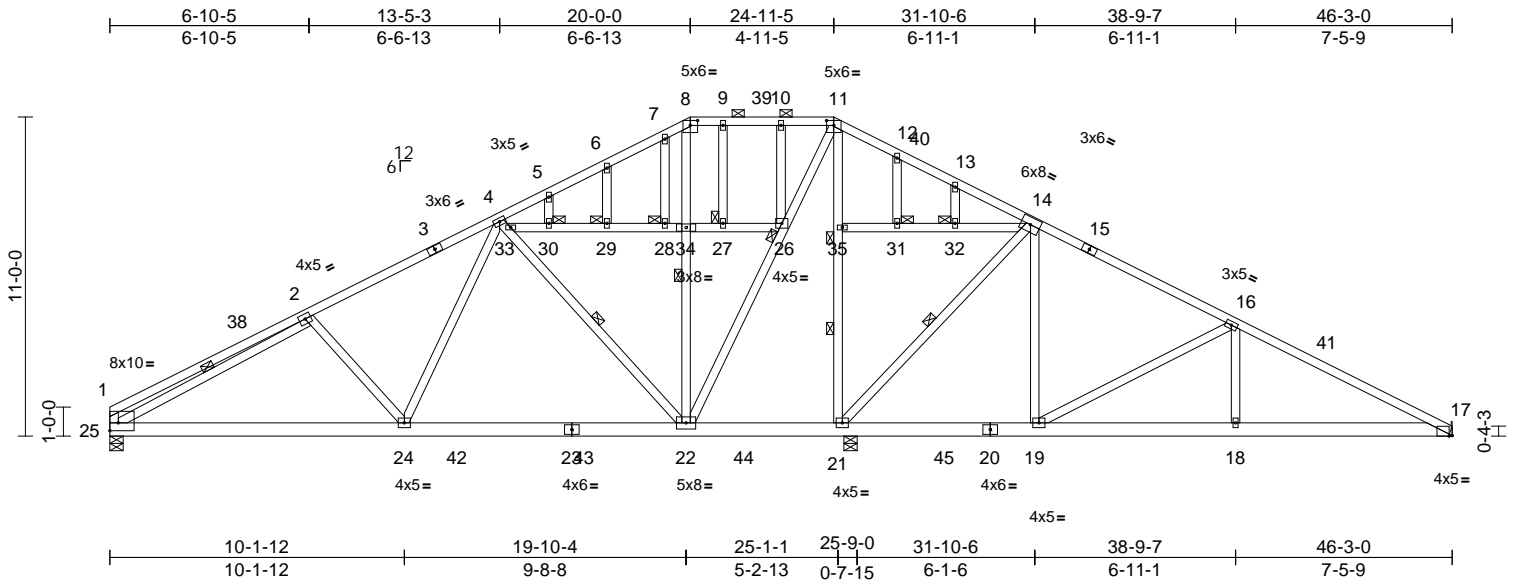

Scale = 1:79.4

Plate Offsets (X, Y): [1:Edge,0-3-4], [8:0-3-0,0-2-0], [11:0-3-0,0-2-0], [17:0-1-4,0-0-3]

Loading	(psf)	Spacing	2-0-0	CSI	DEFL	in	(loc)	l/defl	L/d	PLATES	GRIP	
TCLL (roof)	20.0	Plate Grip DOL	1.15	TC	0.86	Vert(LL)	-0.11	22-24	>999	240	MT20	244/190
Snow (Pf)	20.0	Lumber DOL	1.15	BC	0.53	Vert(CT)	-0.18	22-24	>999	180		
TCDL	10.0	Rep Stress Incr	YES	WB	1.00	Horz(CT)	0.03	17	n/a	n/a		
BCLL	0.0*	Code	IRC2018/TPI2014	Matrix-MSH								
BCDL	10.0											
											Weight: 364 lb	FT = 20%

LUMBER	
TOP CHORD	2x4 SP No.2
BOT CHORD	2x6 SP No.2
WEBS	2x4 SP No.3 *Except* 22-8,22-11,21-11:2x4 SP No.2
OTHERS	2x4 SP No.3
BRACING	
TOP CHORD	Structural wood sheathing directly applied or 2-2-0 oc purlins, except end verticals, and 2-0-0 oc purlins (6-0-0 max.): 8-11.
BOT CHORD	Rigid ceiling directly applied or 6-0-0 oc bracing.
WEBS	1 Row at midpt 4-22, 8-22, 21-35, 14-21, 2-25
JOINTS	1 Brace at Jt(s): 26, 27, 28, 29, 30, 31, 32, 35
REACTIONS	(size)
	17= Mechanical, 21=0-5-8, 25=0-5-8
	Max Horiz 25=171 (LC 15)
	Max Uplift 17=93 (LC 15), 21=173 (LC 15), 25=113 (LC 14)
	Max Grav 17=669 (LC 38), 21=2815 (LC 46), 25=943 (LC 36)
FORCES	(lb) - Maximum Compression/Maximum Tension
TOP CHORD	1-2=535/113, 2-4=1170/194, 4-5=309/126, 5-6=240/162, 6-7=224/172, 7-8=163/181, 8-9=198/173, 9-10=198/173, 10-11=192/173, 11-12=0/820, 12-13=0/787, 13-14=0/732, 14-16=308/110, 16-17=1020/162, 1-25=391/114
BOT CHORD	24-25=256/1136, 22-24=104/704, 21-22=692/273, 19-21=58/185, 18-19=57/835, 17-18=57/835

WEBS	
	2-24=343/214, 4-24=32/750, 4-33=953/221, 22-33=986/235, 22-34=368/70, 8-34=300/49, 22-26=172/1505, 11-26=183/1498, 21-35=2048/201, 11-35=1976/175, 14-21=1101/228, 14-19=0/653, 16-19=874/198, 16-18=0/340, 2-25=894/97, 10-26=192/51, 9-27=36/34, 7-28=39/6, 6-29=109/43, 5-30=18/44, 12-31=100/37, 13-32=14/8, 30-33=53/79, 29-30=53/79, 28-29=53/79, 28-34=53/79, 27-34=49/84, 26-27=49/84, 31-35=74/6, 31-32=74/6, 14-32=71/6

NOTES

- Unbalanced roof live loads have been considered for this design.
- Wind: ASCE 7-16; Vult=130mph (3-second gust) Vasd=103mph; TC DL=6.0psf; BCDL=6.0psf; h=25ft; Cat. II; Exp B; Enclosed; MWFRS (envelope) exterior zone and C-C Exterior(2E) 0-1-12 to 4-9-4, Interior (1) 4-9-4 to 13-5-3, Exterior(2R) 13-5-3 to 31-9-3, Interior (1) 31-9-3 to 41-6-12, Exterior(2E) 41-6-12 to 46-2-4 zone; cantilever left and right exposed; end vertical left and right exposed; C-C for members and forces & MWFRS for reactions shown; Lumber DOL=1.60 plate grip DOL=1.60
- Truss designed for wind loads in the plane of the truss only. For studs exposed to wind (normal to the face), see Standard Industry Gable End Details as applicable, or consult qualified building designer as per ANSI/TPI 1.
- TCLL: ASCE 7-16; Pr=20.0 psf (roof LL: Lum DOL=1.15 Plate DOL=1.15); Pf=20.0 psf (Lum DOL=1.15 Plate DOL=1.15); Is=1.0; Rough Cat B; Fully Exp.; Ce=0.9; Cs=1.00; Ct=1.10
- Unbalanced snow loads have been considered for this design.
- Provide adequate drainage to prevent water ponding.
- All plates are 2x4 MT20 unless otherwise indicated.

- Gable studs spaced at 2-0-0 oc.
- This truss has been designed for a 10.0 psf bottom chord live load nonconcurrent with any other live loads.
- * This truss has been designed for a live load of 20.0psf on the bottom chord in all areas where a rectangle 3-06-00 tall by 2-00-00 wide will fit between the bottom chord and any other members, with BCDL = 10.0psf.
- Refer to girder(s) for truss to truss connections.
- Provide mechanical connection (by others) of truss to bearing plate capable of withstanding 93 lb uplift at joint 17.
- One H2.5A Simpson Strong-Tie connectors recommended to connect truss to bearing walls due to UPLIFT at jt(s) 21 and 25. This connection is for uplift only and does not consider lateral forces.
- This truss is designed in accordance with the 2018 International Residential Code sections R502.11.1 and R802.10.2 and referenced standard ANSI/TPI 1.
- Graphical purlin representation does not depict the size or the orientation of the purlin along the top and/or bottom chord.

LOAD CASE(S) Standard

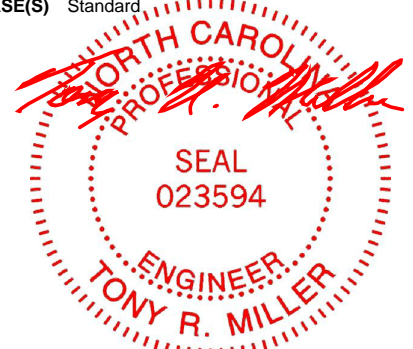

April 1, 2024

WARNING - Verify design parameters and READ NOTES ON THIS AND INCLUDED MITEK REFERENCE PAGE MII-7473 rev. 1/2/2023 BEFORE USE.

Design valid for use only with MITek® connectors. This design is based only upon parameters shown, and is for an individual building component, not a truss system. Before use, the building designer must verify the applicability of design parameters and properly incorporate this design into the overall building design. Bracing indicated is to prevent buckling of individual truss web and/or chord members only. Additional temporary and permanent bracing is always required for stability and to prevent collapse with possible personal injury and property damage. For general guidance regarding the fabrication, storage, delivery, erection and bracing of trusses and truss systems, see ANSI/TPI Quality Criteria and DSB-22 available from Truss Plate Institute (www.tpinst.org) and BCSI Building Component Safety Information available from the Structural Building Component Association (www.sbcacomponents.com)



818 Soundside Road
Edenton, NC 27932

Job 24030153-01	Truss A4	Truss Type Piggyback Base	Qty 3	Ply 1	142 Serenity-Roof-B329 B LH CP Job Reference (optional)	164576270
--------------------	-------------	------------------------------	----------	----------	--	-----------

Carter Components (Sanford, NC), Sanford, NC - 27332,

Run: 9.03 S 8.73 Mar 21 2024 Print: 8.730 S Mar 21 2024 MITek Industries, Inc. Fri Mar 29 10:41:36

Page: 1

ID:SHDhqqFyTAFw4NPKQp_EkzMC?T-RfC?PsB70Hq3NSgPqnL8w3uTXbGKWrCdoi7J4zJC?f

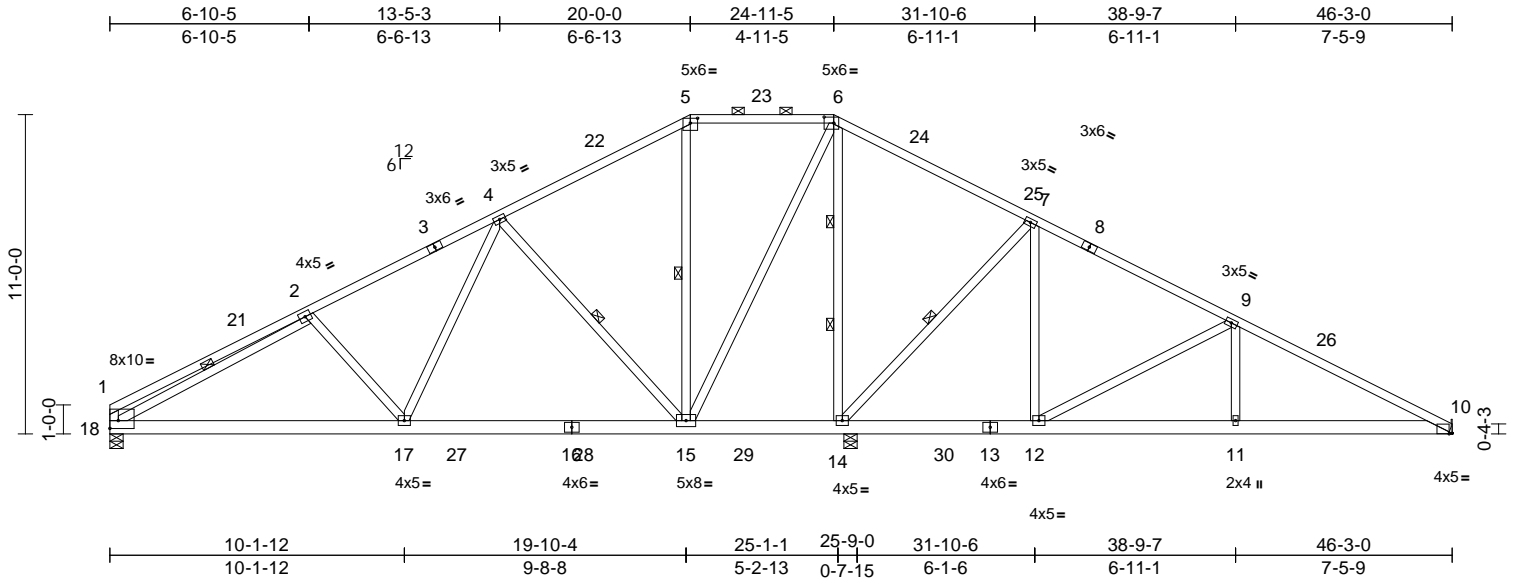

Loading	(psf)	Spacing	2-0-0	CSI	DEFL	in	(loc)	l/defl	L/d	PLATES	GRIP	
TCLL (roof)	20.0	Plate Grip DOL	1.15	TC	0.95	Vert(LL)	-0.11	15-17	>999	240	MT20	244/190
Snow (Pf)	20.0	Lumber DOL	1.15	BC	0.53	Vert(CT)	-0.18	15-17	>999	180		
TCDL	10.0	Rep Stress Incr	YES	WB	0.99	Horz(CT)	0.03	10	n/a	n/a		
BCLL	0.0*	Code	IRC2018/TPI2014	Matrix-MSH								
BCDL	10.0											
											Weight: 316 lb	FT = 20%

LUMBER

TOP CHORD 2x4 SP No.2
 BOT CHORD 2x6 SP No.2
 WEBS 2x4 SP No.3 *Except* 15-5,15-6,14-6:2x4 SP No.2

BRACING

TOP CHORD Structural wood sheathing directly applied or 2-2-0 oc purlins, except end verticals, and 2-0-0 oc purlins (6-0-0 max.): 5-6.
 BOT CHORD Rigid ceiling directly applied or 6-0-0 oc bracing.
 WEBS 1 Row at midpt 4-15, 5-15, 7-14, 2-18
 WEBS 2 Rows at 1/3 pts 6-14

REACTIONS (size) 10= Mechanical, 14=0-5-8, 18=0-5-8
 Max Horiz 18=171 (LC 15)
 Max Uplift 10=95 (LC 15), 14=170 (LC 15), 18=114 (LC 14)
 Max Grav 10=666 (LC 38), 14=2825 (LC 46), 18=940 (LC 36)

FORCES (lb) - Maximum Compression/Maximum Tension
 TOP CHORD 1-2=538/115, 2-4=1161/195, 4-5=283/183, 5-6=161/172, 6-7=0/806, 7-9=310/116, 9-10=1005/164, 1-18=395/116
 BOT CHORD 17-18=255/1126, 15-17=108/700, 14-15=701/270, 12-14=53/200, 11-12=58/819, 10-11=58/819
 WEBS 2-17=336/209, 4-17=29/746, 4-15=1016/240, 5-15=381/68, 6-15=173/1502, 6-14=2026/194, 7-14=1155/233, 7-12=0/647, 9-12=-862/191, 9-11=0/344, 2-18=881/95

- Wind: ASCE 7-16; Vult=130mph (3-second gust) Vasd=103mph; TCDL=6.0psf; BCDL=6.0psf; h=25ft; Cat. II; Exp B; Enclosed; MWFRS (envelope) exterior zone and C-C Exterior(2E) 0-1-12 to 4-9-4, Interior (1) 4-9-4 to 13-5-3, Exterior(2R) 13-5-3 to 31-5-13, Interior (1) 31-5-13 to 41-6-12, Exterior(2E) 41-6-12 to 46-2-4 zone; cantilever left and right exposed; end vertical left and right exposed; C-C for members and forces & MWFRS for reactions shown; Lumber DOL=1.60 plate grip DOL=1.60
- TCLL: ASCE 7-16; Pr=20.0 psf (roof LL: Lum DOL=1.15 Plate DOL=1.15); Pf=20.0 psf (Lum DOL=1.15 Plate DOL=1.15); Is=1.0; Rough Cat B; Fully Exp.; Ce=0.9; Cs=1.00; Ct=1.10
- Unbalanced snow loads have been considered for this design.
- Provide adequate drainage to prevent water ponding.
- This truss has been designed for a 10.0 psf bottom chord live load nonconcurrent with any other live loads.
- * This truss has been designed for a live load of 20.0psf on the bottom chord in all areas where a rectangle 3-06-00 tall by 2-00-00 wide will fit between the bottom chord and any other members, with BCDL = 10.0psf.
- Refer to girder(s) for truss to truss connections.
- Provide mechanical connection (by others) of truss to bearing plate capable of withstanding 95 lb uplift at joint 10.
- One H2.5A Simpson Strong-Tie connectors recommended to connect truss to bearing walls due to UPLIFT at jt(s) 14 and 18. This connection is for uplift only and does not consider lateral forces.
- This truss is designed in accordance with the 2018 International Residential Code sections R502.11.1 and R802.10.2 and referenced standard ANSI/TPI 1.
- Graphical purlin representation does not depict the size or the orientation of the purlin along the top and/or bottom chord.

LOAD CASE(S) Standard



April 1, 2024

Job 24030153-01	Truss A2	Truss Type Piggyback Base	Qty 2	Ply 1	142 Serenity-Roof-B329 B LH CP Job Reference (optional)	I64576271
--------------------	-------------	------------------------------	----------	----------	--	-----------

Carter Components (Sanford, NC), Sanford, NC - 27332,

Run: 9.03 S 8.73 Mar 21 2024 Print: 8.730 S Mar 21 2024 MiTek Industries, Inc. Fri Mar 29 10:41:36

Page: 1

ID:NTX20ti5HLIEJWYTMdz761zMBzb-RfC?PsB70Hq3NSgPqnL8w3uITXbGKWrCDoi7J4zJC?

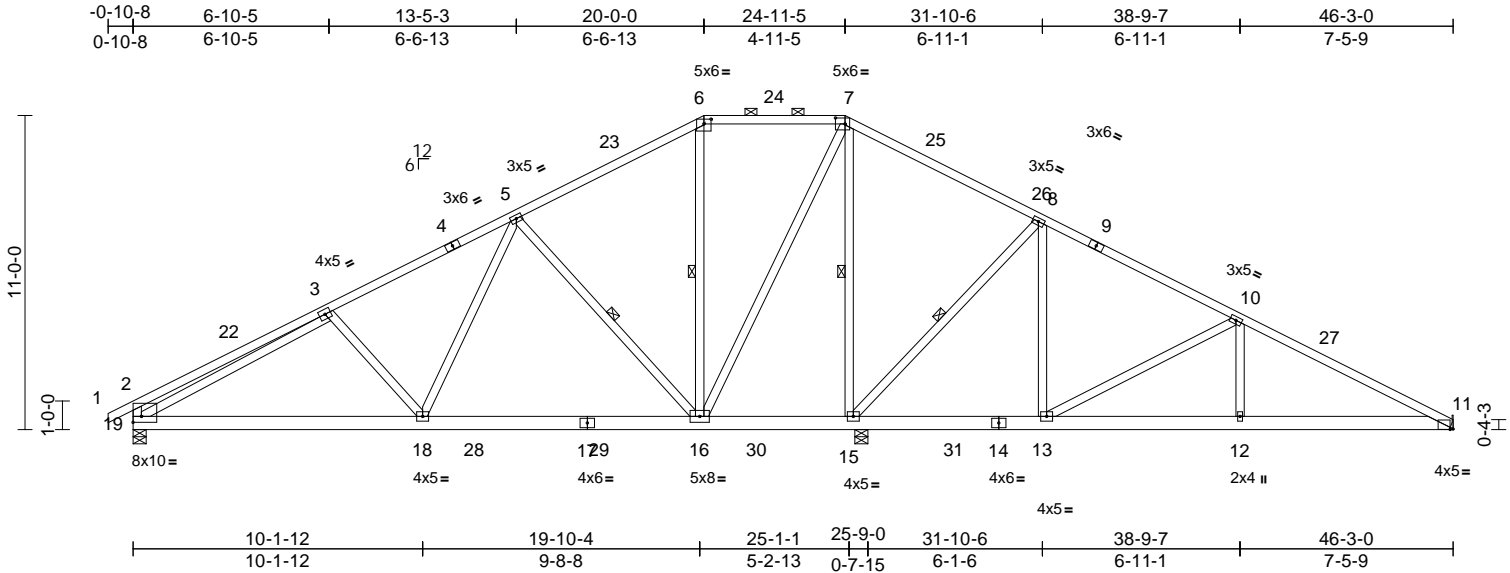

Scale = 1:80.7

Plate Offsets (X, Y): [6:0-3-0,0-2-0], [7:0-4-0,0-2-8], [11:0-1-4,0-0-3], [19:Edge,0-2-8]

Loading	(psf)	Spacing	2-0-0	CSI	DEFL	in	(loc)	l/defl	L/d	PLATES	GRIP	
TCLL (roof)	20.0	Plate Grip DOL	1.15	TC	0.95	Vert(LL)	-0.11	16-18	>999	240	MT20	244/190
Snow (Pf)	20.0	Lumber DOL	1.15	BC	0.53	Vert(CT)	-0.18	16-18	>999	180		
TCDL	10.0	Rep Stress Incr	YES	WB	1.00	Horz(CT)	0.03	11	n/a	n/a		
BCLL	0.0*	Code	IRC2018/TPI2014	Matrix-MSH								
BCDL	10.0											
											Weight: 318 lb	FT = 20%

LUMBER
TOP CHORD 2x4 SP No.2
BOT CHORD 2x6 SP No.2
WEBS 2x4 SP No.3 *Except* 16-6,15-7,16-7:2x4 SP No.2

BRACING
TOP CHORD Structural wood sheathing directly applied or 2-2-0 oc purlins, except end verticals, and 2-0-0 oc purlins (6-0-0 max.): 6-7.
BOT CHORD Rigid ceiling directly applied or 6-0-0 oc bracing.
WEBS 1 Row at midpt 6-16, 7-15, 8-15, 5-16

REACTIONS (size)
11= Mechanical, 15=0-5-8, 19=0-5-8
Max Horiz 19=163 (LC 15)
Max Uplift 11=96 (LC 15), 15=168 (LC 15), 19=136 (LC 14)
Max Grav 11=669 (LC 39), 15=2817 (LC 47), 19=995 (LC 37)

FORCES (lb) - Maximum Compression/Maximum Tension
TOP CHORD 1-2=0/27, 2-3=643/173, 3-5=1164/198, 5-6=290/180, 6-7=167/176, 7-8=0/795, 8-10=317/119, 10-11=1016/167, 2-19=500/172
BOT CHORD 18-19=255/1123, 16-18=112/705, 15-16=692/267, 13-15=44/206, 12-13=60/829, 11-12=60/829
WEBS 3-18=325/205, 5-18=26/738, 6-16=377/65, 7-15=2016/188, 8-13=0/647, 10-12=0/344, 3-19=787/38, 7-16=170/1496, 8-15=1155/233, 10-13=862/191, 5-16=1016/240

NOTES
1) Unbalanced roof live loads have been considered for this design.

- Wind: ASCE 7-16; Vult=130mph (3-second gust) Vasd=103mph; TCDL=6.0psf; BCDL=6.0psf; h=25ft; Cat. II; Exp B; Enclosed; MWFRS (envelope) exterior zone and C-C Exterior(2E) -0-10-8 to 3-9-0, Interior (1) 3-9-0 to 13-5-3, Exterior(2R) 13-5-3 to 31-5-13, Interior (1) 31-5-13 to 41-6-12, Exterior(2E) 41-6-12 to 46-2-4 zone; cantilever left and right exposed; end vertical left and right exposed; C-C for members and forces & MWFRS for reactions shown; Lumber DOL=1.60 plate grip DOL=1.60
- TCLL: ASCE 7-16; Pr=20.0 psf (roof LL: Lum DOL=1.15 Plate DOL=1.15); Pf=20.0 psf (Lum DOL=1.15 Plate DOL=1.15); Is=1.0; Rough Cat B; Fully Exp.; Ce=0.9; Cs=1.00; Ct=1.10
- Unbalanced snow loads have been considered for this design.
- This truss has been designed for greater of min roof live load of 12.0 psf or 1.00 times flat roof load of 20.0 psf on overhangs non-concurrent with other live loads.
- Provide adequate drainage to prevent water ponding.
- This truss has been designed for a 10.0 psf bottom chord live load nonconcurrent with any other live loads.
- * This truss has been designed for a live load of 20.0psf on the bottom chord in all areas where a rectangle 3-06-00 tall by 2-00-00 wide will fit between the bottom chord and any other members, with BCDL = 10.0psf.
- Refer to girder(s) for truss to truss connections.
- Provide mechanical connection (by others) of truss to bearing plate capable of withstanding 96 lb uplift at joint 11.
- One H2.5A Simpson Strong-Tie connectors recommended to connect truss to bearing walls due to UPLIFT at jt(s) 19 and 15. This connection is for uplift only and does not consider lateral forces.
- This truss is designed in accordance with the 2018 International Residential Code sections R502.11.1 and R802.10.2 and referenced standard ANSI/TPI 1.

13) Graphical purlin representation does not depict the size or the orientation of the purlin along the top and/or bottom chord.
LOAD CASE(S) Standard



April 1, 2024

WARNING - Verify design parameters and READ NOTES ON THIS AND INCLUDED MITEK REFERENCE PAGE MII-7473 rev. 1/2/2023 BEFORE USE.

Design valid for use only with MiTek® connectors. This design is based only upon parameters shown, and is for an individual building component, not a truss system. Before use, the building designer must verify the applicability of design parameters and properly incorporate this design into the overall building design. Bracing indicated is to prevent buckling of individual truss web and/or chord members only. Additional temporary and permanent bracing is always required for stability and to prevent collapse with possible personal injury and property damage. For general guidance regarding the fabrication, storage, delivery, erection and bracing of trusses and truss systems, see **ANSI/TPI Quality Criteria and DSB-22** available from Truss Plate Institute (www.tpinst.org) and **BCSI Building Component Safety Information** available from the Structural Building Component Association (www.sbcacomponents.com)



818 Soundside Road
Edenton, NC 27932

Job 24030153-01	Truss A1	Truss Type Piggyback Base	Qty 1	Ply 1	142 Serenity-Roof-B329 B LH CP Job Reference (optional)	I64576272
--------------------	-------------	------------------------------	----------	----------	--	-----------

Carter Components (Sanford, NC), Sanford, NC - 27332,

Run: 9.03 S 8.73 Mar 21 2024 Print: 8.730 S Mar 21 2024 MiTek Industries, Inc. Fri Mar 29 10:41:36

Page: 1

ID:AN2iTM0PAKZYRWXSt4QE9WzMBzB-RfC?PsB70Hq3NSgPqnL8w3uITXbGKwRcDoi7J4zJC7f

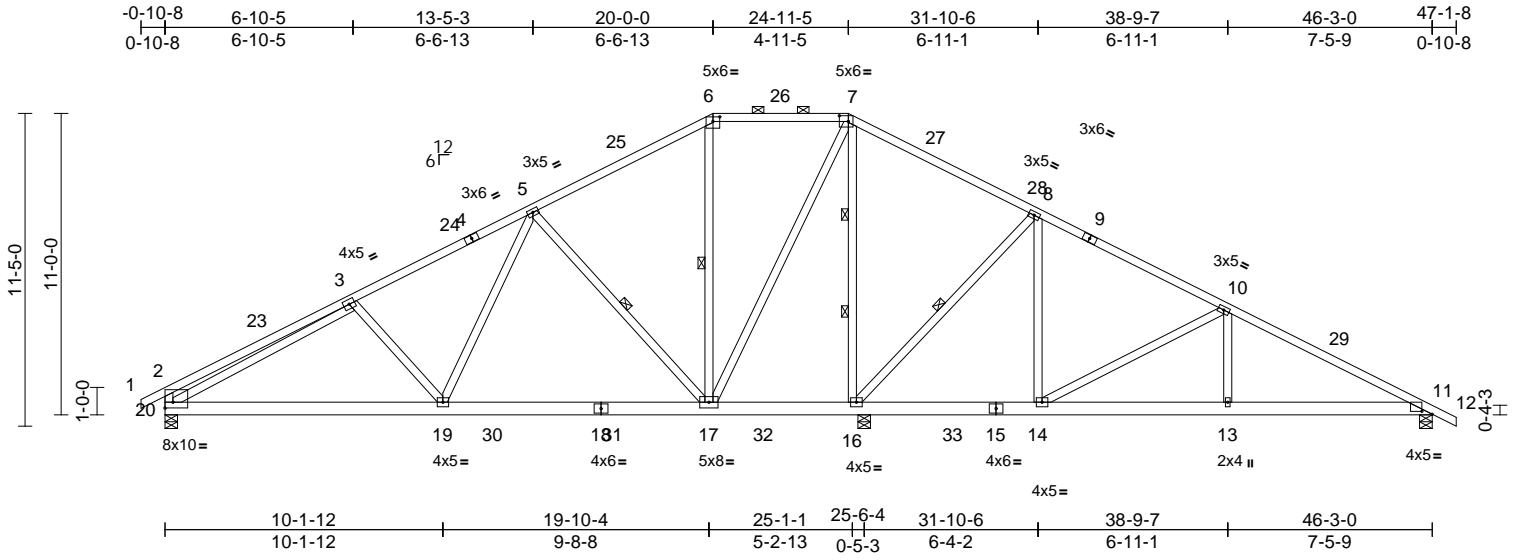

Scale = 1:84.1

Plate Offsets (X, Y): [6:0-3-0,0-2-0], [7:0-4-0,0-2-8], [11:0-4-8,0-1-5], [20:Edge,0-2-8]

Loading	(psf)	Spacing	2-0-0	CSI	DEFL	in	(loc)	l/defl	L/d	PLATES	GRIP	
TCLL (roof)	20.0	Plate Grip DOL	1.15	TC	0.95	Vert(LL)	-0.11	17-19	>999	240	MT20	244/190
Snow (Pf)	20.0	Lumber DOL	1.15	BC	0.53	Vert(CT)	-0.18	17-19	>999	180		
TCDL	10.0	Rep Stress Incr	YES	WB	1.00	Horz(CT)	0.03	11	n/a	n/a		
BCLL	0.0*	Code	IRC2018/TPI2014	Matrix-MSH								
BCDL	10.0											
											Weight: 319 lb	FT = 20%

LUMBER
TOP CHORD 2x4 SP No.2
BOT CHORD 2x6 SP No.2
WEBS 2x4 SP No.3 *Except* 17-6,16-7,17-7:2x4 SP No.2

BRACING
TOP CHORD Structural wood sheathing directly applied or 2-2-0 oc purlins, except end verticals, and 2-0-0 oc purlins (6-0-0 max.): 6-7.
BOT CHORD Rigid ceiling directly applied or 6-0-0 oc bracing.
WEBS 1 Row at midpt 6-17, 8-16, 5-17
WEBS 2 Rows at 1/3 pts 7-16

REACTIONS
(size) 11=0-5-8, 16=0-5-8, 20=0-5-8
Max Horiz 20=-178 (LC 15)
Max Uplift 11=-115 (LC 15), 16=-166 (LC 15), 20=-137 (LC 14)
Max Grav 11=707 (LC 39), 16=2835 (LC 47), 20=995 (LC 37)

FORCES
(lb) - Maximum Compression/Maximum Tension
TOP CHORD 1-2=0/27, 2-3=-640/174, 3-5=-1146/200, 5-6=-285/196, 6-7=-163/178, 7-8=0/819, 8-10=-298/121, 10-11=-998/167, 11-12=0/23, 2-20=-499/173
BOT CHORD 19-20=-250/1110, 17-19=-107/709, 16-17=-710/281, 14-16=-54/189, 13-14=-46/817, 11-13=-46/817
WEBS 3-19=-327/205, 5-19=-26/739, 6-17=-386/64, 7-16=-2035/180, 8-14=0/649, 10-13=0/346, 3-20=-796/40, 7-17=-169/1505, 8-16=-1156/232, 10-14=-868/190, 5-17=-1017/240

NOTES
1) Unbalanced roof live loads have been considered for this design.

- Wind: ASCE 7-16; Vult=130mph (3-second gust) Vasd=103mph; TCDL=6.0psf; BCDL=6.0psf; h=25ft; Cat. II; Exp B; Enclosed; MWFRS (envelope) exterior zone and C-C Exterior(2E) -0-10-8 to 3-9-0, Interior (1) 3-9-0 to 13-5-3, Exterior(2R) 13-5-3 to 31-5-13, Interior (1) 31-5-13 to 42-6-0, Exterior(2E) 42-6-0 to 47-1-8 zone; cantilever left and right exposed; end vertical left and right exposed; C-C for members and forces & MWFRS for reactions shown; Lumber DOL=1.60 plate grip DOL=1.60
- TCLL: ASCE 7-16; Pr=20.0 psf (roof LL: Lum DOL=1.15 Plate DOL=1.15); Pf=20.0 psf (Lum DOL=1.15 Plate DOL=1.15); Is=1.0; Rough Cat B; Fully Exp.; Ce=0.9; Cs=1.00; Ct=1.10
- Unbalanced snow loads have been considered for this design.
- This truss has been designed for greater of min roof live load of 12.0 psf or 1.00 times flat roof load of 20.0 psf on overhangs non-concurrent with other live loads.
- Provide adequate drainage to prevent water ponding.
- This truss has been designed for a 10.0 psf bottom chord live load nonconcurrent with any other live loads.
- * This truss has been designed for a live load of 20.0psf on the bottom chord in all areas where a rectangle 3-06-00 tall by 2-00-00 wide will fit between the bottom chord and any other members, with BCDL = 10.0psf.
- One H2.5A Simpson Strong-Tie connectors recommended to connect truss to bearing walls due to UPLIFT at jt(s) 20, 11, and 16. This connection is for uplift only and does not consider lateral forces.
- This truss is designed in accordance with the 2018 International Residential Code sections R502.11.1 and R802.10.2 and referenced standard ANSI/TPI 1.
- Graphical purlin representation does not depict the size or the orientation of the purlin along the top and/or bottom chord.

LOAD CASE(S) Standard



April 1, 2024

Job 24030153-01	Truss A	Truss Type Attic	Qty 2	Ply 1	142 Serenity-Roof-B329 B LH CP Job Reference (optional)	164576273
--------------------	------------	---------------------	----------	----------	--	-----------

Carter Components (Sanford, NC), Sanford, NC - 27332,

Run: 9.03 S 8.73 Mar 21 2024 Print: 8.730 S Mar 21 2024 MITek Industries, Inc. Fri Mar 29 10:41:34

Page: 1

ID:ZPnjVCN8PSJoBx1Aeinw9zMBNV-RfC?PsB70Hq3NSgPqnL8w3uITXbGKwRCDoi7J4zJC?F

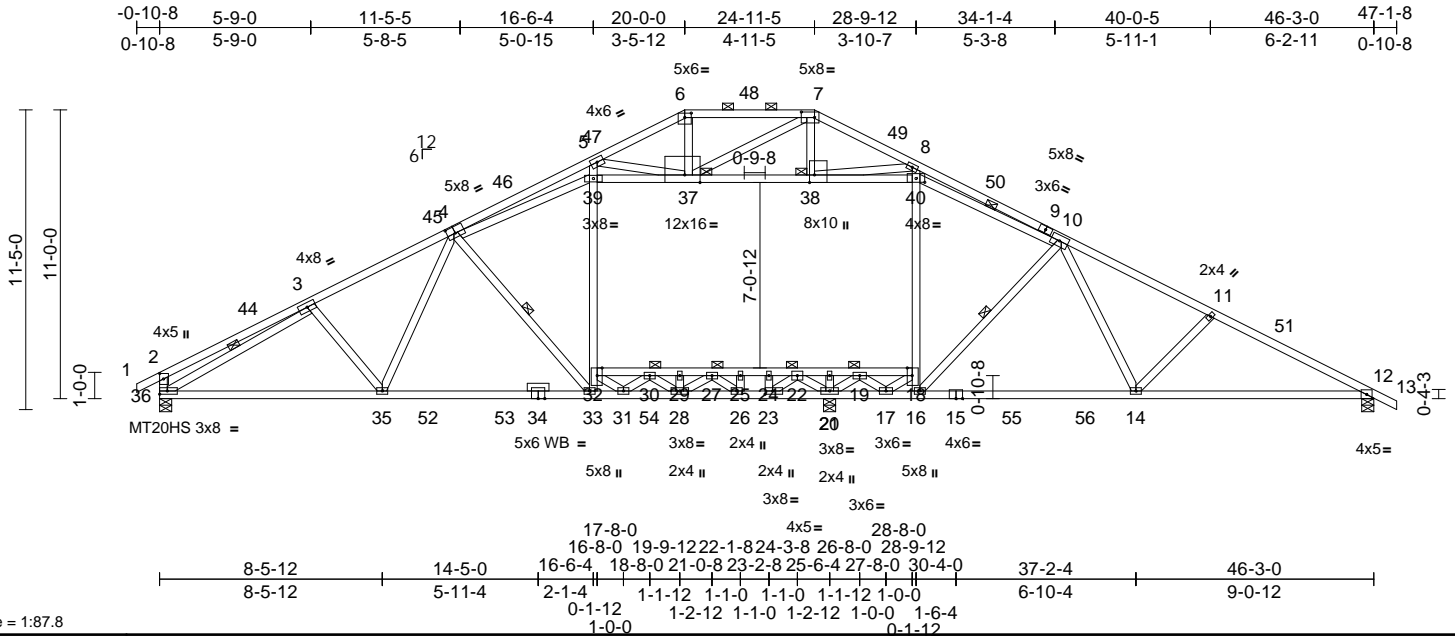

Scale = 1:87.8
Plate Offsets (X, Y): [2:0-2-8,0-1-12], [4:0-3-12,0-3-0], [6:0-3-0,0-2-0], [7:0-6-0,0-2-8], [8:Edge,0-2-4], [23:0-3-8,0-1-8], [32:Edge,0-2-4], [37:0-7-0,0-3-8], [38:0-3-8,0-2-4], [40:0-4-0,0-1-12]

Loading	(psf)	Spacing	2-0-0	CSI	DEFL	in	(loc)	l/defl	L/d	PLATES	GRIP	
TCLL (roof)	20.0	Plate Grip DOL	1.15	TC	0.82	Vert(LL)	-0.58	33-35	>528	240	MT20	244/190
Snow (Pf)	20.0	Lumber DOL	1.15	BC	0.96	Vert(CT)	-0.93	33-35	>326	180	MT20HS	187/143
TCDL	10.0	Rep Stress Incr	YES	WB	0.98	Horz(CT)	0.14	12	n/a	n/a		
BCLL	0.0*	Code	IRC2018/TPI2014	Matrix-MSH		Attic	-0.35	18-32	>423	360		
BCDL	10.0											
											Weight: 338 lb	FT = 20%

LUMBER
TOP CHORD 2x4 SP No.2
BOT CHORD 2x4 SP No.1
WEBS 2x4 SP No.3 *Except* 5-33,8-16:2x4 SP No.1, 39-40:2x4 SP No.2
OTHERS 2x4 SP No.3

BRACING
TOP CHORD Structural wood sheathing directly applied or 2-2-0 oc purlins, except end verticals, and 2-0-0 oc purlins (4-3-12 max.): 6-7.
BOT CHORD Rigid ceiling directly applied or 2-2-0 oc bracing.
WEBS 1 Row at midpt 4-33, 10-16, 3-36, 10-40
JOINTS 1 Brace at Jt(s): 30, 19, 37, 38, 27, 22

REACTIONS (size) 12=0-5-8, 20=0-5-8, 36=0-5-8
Max Horiz 36=177 (LC 19)
Max Uplift 12=8 (LC 15), 36=120 (LC 14)
Max Grav 12=1701 (LC 48), 20=2301 (LC 40), 36=2021 (LC 38)

FORCES (lb) - Maximum Compression/Maximum Tension
TOP CHORD 1-2=0/27, 2-3=598/112, 3-5=3844/226, 5-6=1345/148, 6-7=1193/151, 7-8=899/145, 8-10=464/324, 10-11=3214/83, 11-12=3439/91, 12-13=0/23, 2-36=471/139
BOT CHORD 35-36=230/2853, 33-35=114/2729, 31-33=13/2608, 28-31=0/2805, 26-28=253/2293, 23-26=974/1548, 20-23=1887/797, 17-20=1334/531, 16-17=0/1771, 14-16=0/2484, 12-14=0/3035, 30-32=614/165, 29-30=793/741, 27-29=793/741, 25-27=443/2016, 24-25=443/2016, 22-24=443/2016, 21-22=213/4213, 19-21=213/4213, 18-19=0/1927

WEBS
3-35=57/188, 4-35=27/386, 4-33=766/205, 32-33=39/765, 32-39=7/998, 5-39=0/1443, 16-18=0/920, 18-40=388/138, 8-40=951/106, 10-16=631/254, 10-14=46/684, 11-14=392/180, 37-39=130/1732, 37-38=1611/118, 38-40=2906/207, 3-36=2852/66, 20-21=440/0, 28-29=128/0, 31-32=380/199, 30-31=345/359, 28-30=423/125, 17-18=1950/59, 17-19=224/1455, 19-20=1633/191, 6-37=0/293, 7-38=126/41, 7-37=74/656, 5-37=2820/185, 8-38=92/1359, 27-28=20/817, 26-27=1287/0, 25-26=0/522, 20-22=1439/0, 22-23=0/1903, 23-24=837/0, 4-39=168/1254, 10-40=2400/161

NOTES
1) Unbalanced roof live loads have been considered for this design.
2) Wind: ASCE 7-16; Vult=130mph (3-second gust) Vasd=103mph; TCDL=6.0psf; BCDL=6.0psf; h=25ft; Cat. II; Exp B; Enclosed; MWFRS (envelope) exterior zone and C-C Exterior(2E) -0-10-8 to 3-9-0, Interior (1) 3-9-0 to 13-5-8, Exterior(2R) 13-5-8 to 31-5-13, Interior (1) 31-5-13 to 42-6-0, Exterior(2E) 42-6-0 to 47-1-8 zone; cantilever left and right exposed ; end vertical left and right exposed;C-C for members and forces & MWFRS for reactions shown; Lumber DOL=1.60 plate grip DOL=1.60
3) TCLL: ASCE 7-16; Pr=20.0 psf (roof LL: Lum DOL=1.15 Plate DOL=1.15); Pf=20.0 psf (Lum DOL=1.15 Plate DOL=1.15); Is=1.0; Rough Cat B; Fully Exp.; Ce=0.9; Cs=1.00; Ct=1.10
4) Unbalanced snow loads have been considered for this design.
5) This truss has been designed for greater of min roof live load of 12.0 psf or 1.00 times flat roof load of 20.0 psf on overhangs non-concurrent with other live loads.

- Provide adequate drainage to prevent water ponding.
- All plates are MT20 plates unless otherwise indicated.
- All plates are 3x5 MT20 unless otherwise indicated.
- This truss has been designed for a 10.0 psf bottom chord live load nonconcurrent with any other live loads.
- * This truss has been designed for a live load of 20.0psf on the bottom chord in all areas where a rectangle 3-06-00 tall by 2-00-00 wide will fit between the bottom chord and any other members, with BCDL = 10.0psf.
- Ceiling dead load (5.0 psf) on member(s). 37-39, 37-38, 38-40; Wall dead load (5.0psf) on member(s).32-39, 18-40
- Bottom chord live load (40.0 psf) and additional bottom chord dead load (5.0 psf) applied only to room. 30-32, 29-30, 27-29, 25-27, 24-25, 22-24, 21-22, 19-21, 18-19
- One H2.5A Simpson Strong-Tie connectors recommended to connect truss to bearing walls due to UPLIFT at jt(s) 36 and 12. This connection is for uplift only and does not consider lateral forces.
- This truss is designed in accordance with the 2018 International Residential Code sections R502.11.1 and R802.10.2 and referenced standard ANSI/TPI 1.



April 1, 2024

Continued on page 2

WARNING - Verify design parameters and READ NOTES ON THIS AND INCLUDED MITEK REFERENCE PAGE MII-7473 rev. 1/2/2023 BEFORE USE.

Design valid for use only with MITek® connectors. This design is based only upon parameters shown, and is for an individual building component, not a truss system. Before use, the building designer must verify the applicability of design parameters and properly incorporate this design into the overall building design. Bracing indicated is to prevent buckling of individual truss web and/or chord members only. Additional temporary and permanent bracing is always required for stability and to prevent collapse with possible personal injury and property damage. For general guidance regarding the fabrication, storage, delivery, erection and bracing of trusses and truss systems, see **ANSI/TPI1 Quality Criteria and DSB-22** available from Truss Plate Institute (www.tpinst.org) and **BCSI Building Component Safety Information** available from the Structural Building Component Association (www.sbacomponents.com)



818 Soundside Road
Edenton, NC 27932

Job	Truss	Truss Type	Qty	Ply	142 Serenity-Roof-B329 B LH CP	I64576273
24030153-01	A	Attic	2	1	Job Reference (optional)	

Carter Components (Sanford, NC), Sanford, NC - 27332,

Run: 9.03 S 8.73 Mar 21 2024 Print: 8.730 S Mar 21 2024 MiTek Industries, Inc. Fri Mar 29 10:41:34
 ID:ZPnjjVCN8PSJoBx1Aeinw9zMBNV-RfC?PsB70Hq3NSgPqnL8w3uITXbGKWrCDoi7J4zJC?f

Page: 2

15) Graphical purlin representation does not depict the size or the orientation of the purlin along the top and/or bottom chord.

16) Attic room checked for L/360 deflection.

LOAD CASE(S) Standard

WARNING - Verify design parameters and READ NOTES ON THIS AND INCLUDED MITEK REFERENCE PAGE MII-7473 rev. 1/2/2023 BEFORE USE.

Design valid for use only with MiTek® connectors. This design is based only upon parameters shown, and is for an individual building component, not a truss system. Before use, the building designer must verify the applicability of design parameters and properly incorporate this design into the overall building design. Bracing indicated is to prevent buckling of individual truss web and/or chord members only. Additional temporary and permanent bracing is always required for stability and to prevent collapse with possible personal injury and property damage. For general guidance regarding the fabrication, storage, delivery, erection and bracing of trusses and truss systems, see **ANSI/TP1 Quality Criteria and DSB-22** available from Truss Plate Institute (www.tpinst.org) and **BCSI Building Component Safety Information** available from the Structural Building Component Association (www.sbcacomponents.com)



818 Soundside Road
 Edenton, NC 27932

Job 24030153-01	Truss C1	Truss Type Attic	Qty 3	Ply 1	142 Serenity-Roof-B329 B LH CP Job Reference (optional)	164576274
--------------------	-------------	---------------------	----------	----------	--	-----------

Carter Components (Sanford, NC), Sanford, NC - 27332,

Run: 9.03 S 8.73 Mar 21 2024 Print: 8.730 S Mar 21 2024 MiTek Industries, Inc. Fri Mar 29 10:41:41
ID:dn7xJiaix1KrXXAjYqfRnizMBFG-RfC?PsB70Hq3NSgPqnL8w3lTXbGKwRCDoi7J4zJC?f

Page: 1

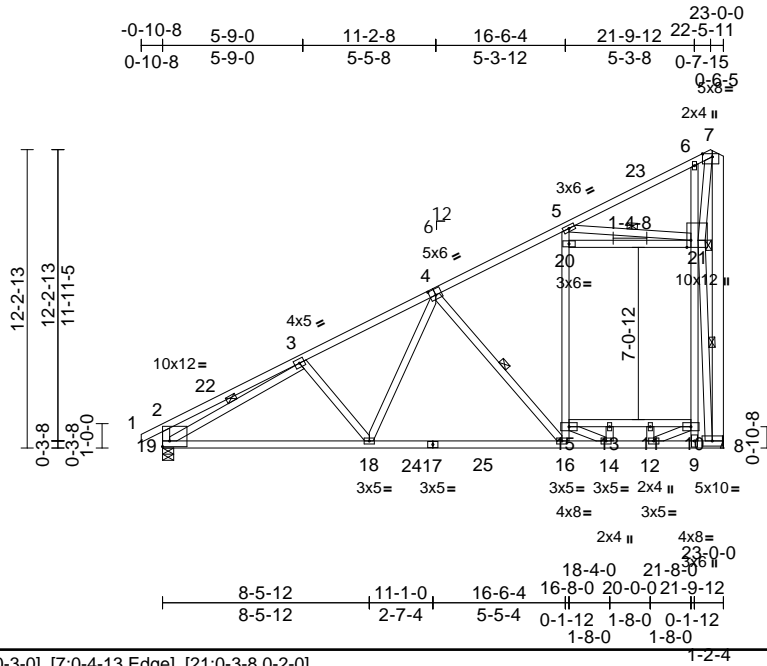

Scale = 1:94.5

Plate Offsets (X, Y): [2:Edge,0-2-12], [4:0-3-0,0-3-0], [7:0-4-13,Edge], [21:0-3-8,0-2-0]

Loading	(psf)	Spacing	2-0-0	CSI	DEFL	in	(loc)	l/defl	L/d	PLATES	GRIP	
TCLL (roof)	20.0	Plate Grip DOL	1.15	TC	0.83	Vert(LL)	-0.41	16-18	>664	240	MT20	244/190
Snow (Pf)	20.0	Lumber DOL	1.15	BC	0.84	Vert(CT)	-0.73	16-18	>370	180		
TCDL	10.0	Rep Stress Incr	YES	WB	0.87	Horz(CT)	0.04	8	n/a	n/a		
BCLL	0.0*	Code	IRC2018/TPI2014	Matrix-MSH		Attic	-0.15	10-15	>419	360		
BCDL	10.0											
											Weight: 215 lb	FT = 20%

LUMBER
TOP CHORD 2x4 SP No.2
BOT CHORD 2x4 SP No.1 *Except* 15-10:2x4 SP No.3, 17-8:2x4 SP No.2
WEBS 2x4 SP No.3 *Except* 5-16,6-9,21-8:2x4 SP 2400F 2.0E, 20-21:2x4 SP No.2, 8-7:2x6 SP No.2

BRACING
TOP CHORD Structural wood sheathing directly applied or 4-5-4 oc purlins, except end verticals.
BOT CHORD Rigid ceiling directly applied or 6-0-0 oc bracing.
WEBS 1 Row at midpt 4-16, 3-19, 5-21, 8-21
JOINTS 1 Brace at Jt(s): 21

REACTIONS (size) 8= Mechanical, 19=0-5-8
Max Horiz 19=421 (LC 14)
Max Uplift 8=-28 (LC 14), 19=-2 (LC 14)
Max Grav 8=1740 (LC 5), 19=1168 (LC 5)

FORCES (lb) - Maximum Compression/Maximum Tension
TOP CHORD 1-2=0/27, 2-3=-463/97, 3-5=-1601/0, 5-6=-154/950, 6-7=-42/663, 2-19=-398/134, 7-8=-285/2782
BOT CHORD 18-19=-326/1557, 16-18=-188/1248, 14-16=-110/1395, 12-14=0/883, 9-12=-115/11, 8-9=-34/481, 13-15=-350/0, 11-13=-350/0, 10-11=-350/0
WEBS 3-18=-169/191, 4-18=-47/537, 4-16=-728/203, 15-16=-66/779, 15-20=0/759, 5-20=0/763, 9-10=-20/550, 10-21=0/1111, 6-21=-640/181, 20-21=-75/858, 3-19=-1302/0, 14-15=-628/164, 13-14=-71/174, 10-12=0/1108, 11-12=-457/5, 5-21=-2256/178, 8-21=-4861/349, 7-21=-3055/262

NOTES

- Wind: ASCE 7-16; Vult=130mph (3-second gust) Vasd=103mph; TCDL=6.0psf; BCDL=6.0psf; h=25ft; Cat II; Exp B; Enclosed; MWFRS (envelope) exterior zone and C-C Exterior(2E) -0-10-8 to 2-1-8, Interior (1) 2-1-8 to 19-9-4, Exterior(2E) 19-9-4 to 22-9-4 zone; cantilever left and right exposed; end vertical left exposed; C-C for members and forces & MWFRS for reactions shown; Lumber DOL=1.60 plate grip DOL=1.60
- TCLL: ASCE 7-16; Pr=20.0 psf (roof LL: Lum DOL=1.15 Plate DOL=1.15); Pf=20.0 psf (Lum DOL=1.15 Plate DOL=1.15); Is=1.0; Rough Cat B; Fully Exp.; Ce=0.9; Cs=1.00; Ct=1.10
- Unbalanced snow loads have been considered for this design.
- This truss has been designed for greater of min roof live load of 12.0 psf or 1.00 times flat roof load of 20.0 psf on overhangs non-concurrent with other live loads.
- This truss has been designed for a 10.0 psf bottom chord live load nonconcurrent with any other live loads.
- * This truss has been designed for a live load of 20.0psf on the bottom chord in all areas where a rectangle 3-06-00 tall by 2-00-00 wide will fit between the bottom chord and any other members, with BCDL = 10.0psf.
- Ceiling dead load (5.0 psf) on member(s).15-20, 10-21
- Bottom chord live load (40.0 psf) and additional bottom chord dead load (5.0 psf) applied only to room. 13-15, 11-13, 10-11
- Refer to girder(s) for truss to truss connections.
- Provide mechanical connection (by others) of truss to bearing plate capable of withstanding 28 lb uplift at joint 8.
- One H2.5A Simpson Strong-Tie connectors recommended to connect truss to bearing walls due to UPLIFT at jt(s) 19. This connection is for uplift only and does not consider lateral forces.

- This truss is designed in accordance with the 2018 International Residential Code sections R502.11.1 and R802.10.2 and referenced standard ANSI/TPI 1.
 - Attic room checked for L/360 deflection.
- LOAD CASE(S)** Standard



April 1, 2024

WARNING - Verify design parameters and READ NOTES ON THIS AND INCLUDED MITEK REFERENCE PAGE MII-7473 rev. 1/2/2023 BEFORE USE.
Design valid for use only with MiTek® connectors. This design is based only upon parameters shown, and is for an individual building component, not a truss system. Before use, the building designer must verify the applicability of design parameters and properly incorporate this design into the overall building design. Bracing indicated is to prevent buckling of individual truss web and/or chord members only. Additional temporary and permanent bracing is always required for stability and to prevent collapse with possible personal injury and property damage. For general guidance regarding the fabrication, storage, delivery, erection and bracing of trusses and truss systems, see **ANSI/TPI Quality Criteria and DSB-22** available from Truss Plate Institute (www.tpinst.org) and **BCSI Building Component Safety Information** available from the Structural Building Component Association (www.sbcacomponents.com)

ENGINEERING BY
TRENCO
A MiTek Affiliate
818 Soundside Road
Edenton, NC 27932

Job 24030153-01	Truss A7GR	Truss Type Flat Girder	Qty 1	Ply 1	142 Serenity-Roof-B329 B LH CP Job Reference (optional)	164576275
--------------------	---------------	---------------------------	----------	----------	--	-----------

Carter Components (Sanford, NC), Sanford, NC - 27332,

Run: 9.03 S 8.73 Mar 21 2024 Print: 8.730 S Mar 21 2024 MITek Industries, Inc. Fri Mar 29 10:41:39

Page: 1

ID:MzC3Fp7GD?OvuFJV4QsXmZMCI5-RfC?PsB70Hq3NSgPqnL8w3uITxBGKwRCDoi7J4zJC?f

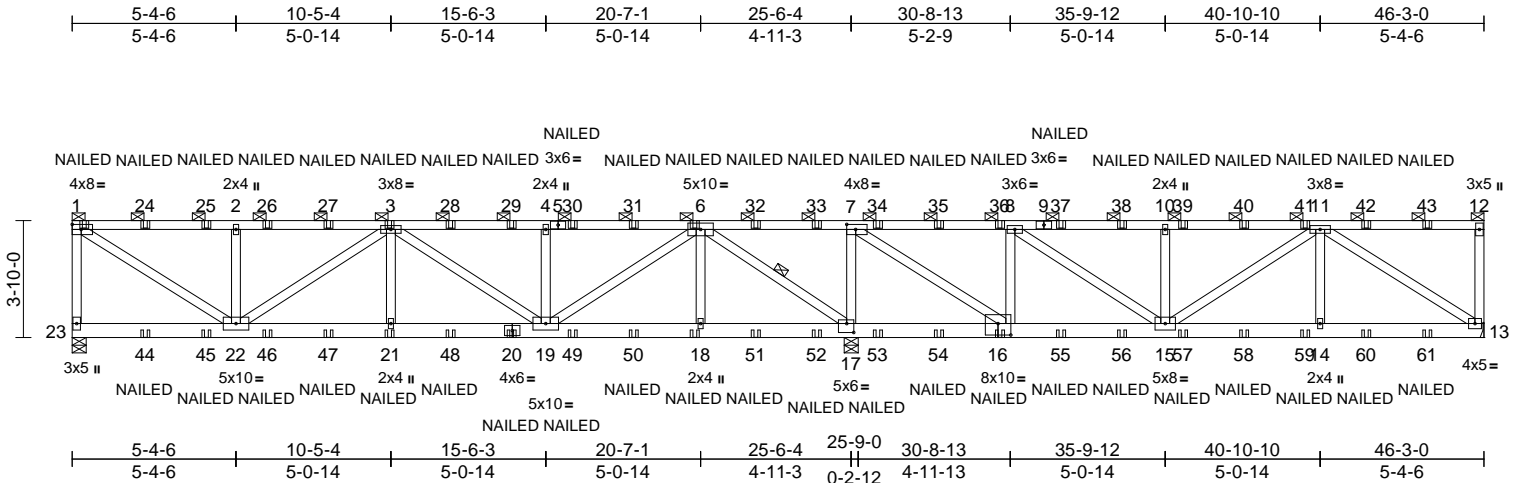

Scale = 1:75.5

Plate Offsets (X, Y): [7:0-3-8,0-2-0], [16:0-5-0,0-4-8], [17:0-2-12,0-3-8]

Loading	(psf)	Spacing	2-0-0	CSI	DEFL	in	(loc)	l/defl	L/d	PLATES	GRIP	
TCLL (roof)	20.0	Plate Grip DOL	1.15	TC	0.98	Vert(LL)	-0.11	19-21	>999	240	MT20	244/190
Snow (Pf)	20.0	Lumber DOL	1.15	BC	0.58	Vert(CT)	-0.19	19-21	>999	180		
TCDL	10.0	Rep Stress Incr	NO	WB	0.90	Horz(CT)	0.03	13	n/a	n/a		
BCLL	0.0*	Code	IRC2018/TPI2014	Matrix-MSH								
BCDL	10.0											
											Weight: 299 lb	FT = 20%

LUMBER

TOP CHORD 2x4 SP No.1 *Except* 9-12:2x4 SP No.2
 BOT CHORD 2x6 SP No.2
 WEBS 2x4 SP No.3 *Except* 22-1,16-7,13-11:2x4 SP No.2

BRACING

TOP CHORD 2-0-0 oc purlins (4-0-0 max.): 1-12, except end verticals.
 BOT CHORD Rigid ceiling directly applied or 4-7-7 oc bracing.
 WEBS 1 Row at midpt 6-17

REACTIONS

(size) 13= Mechanical, 17=0-5-8, 23=0-5-8
 Max Horiz 23=119 (LC 9)
 Max Uplift 13=-242 (LC 8), 17=-962 (LC 9), 23=-354 (LC 8)
 Max Grav 13=1058 (LC 1), 17=4129 (LC 1), 23=1493 (LC 1)

FORCES

(lb) - Maximum Compression/Maximum Tension
 TOP CHORD 1-23=-1415/378, 1-2=-1811/438, 2-3=-1811/438, 3-4=-1865/443, 4-6=-1865/443, 6-7=-552/2286, 7-8=-81/209, 8-10=-1110/291, 10-11=-1110/291, 11-12=-63/44, 12-13=-220/98
 BOT CHORD 22-23=-95/101, 21-22=-611/2380, 19-21=-611/2380, 18-19=-93/243, 17-18=-93/243, 15-17=-2286/553, 14-15=-299/1184, 13-14=-299/1184
 WEBS 1-22=-500/2128, 2-22=-621/284, 3-22=-688/180, 3-21=0/276, 3-19=-624/160, 4-19=-575/261, 6-19=-466/1963, 6-18=0/247, 6-17=-3088/725, 7-17=-2090/604, 7-16=-580/2558, 8-16=-1381/445, 8-15=-312/1403, 10-15=-553/250, 11-15=-90/23, 11-14=0/308, 11-13=-1376/319

NOTES

- 1) Wind: ASCE 7-16; Vult=130mph (3-second gust) Vasd=103mph; TCDL=6.0psf; BCDL=6.0psf; h=25ft; Cat II; Exp B; Enclosed; MWFRS (envelope) exterior zone; cantilever left and right exposed ; end vertical left and right exposed; Lumber DOL=1.60 plate grip DOL=1.60
- 2) TCLL: ASCE 7-16; Pr=20.0 psf (roof LL: Lum DOL=1.15 Plate DOL=1.15); Pf=20.0 psf (Lum DOL=1.15 Plate DOL=1.15); Is=1.0; Rough Cat B; Fully Exp.; Ce=0.9; Cs=1.00; Ct=1.10
- 3) Unbalanced snow loads have been considered for this design.
- 4) Provide adequate drainage to prevent water ponding.
- 5) This truss has been designed for a 10.0 psf bottom chord live load nonconcurrent with any other live loads.
- 6) * This truss has been designed for a live load of 20.0psf on the bottom chord in all areas where a rectangle 3-06-00 tall by 2-00-00 wide will fit between the bottom chord and any other members.
- 7) Refer to girder(s) for truss to truss connections.
- 8) Provide mechanical connection (by others) of truss to bearing plate capable of withstanding 242 lb uplift at joint 13.
- 9) One H2.5A Simpson Strong-Tie connectors recommended to connect truss to bearing walls due to UPLIFT at jt(s) 23. This connection is for uplift only and does not consider lateral forces.
- 10) H10A Simpson Strong-Tie connectors recommended to connect truss to bearing walls due to UPLIFT at jt(s) 17. This connection is for uplift only and does not consider lateral forces.
- 11) This truss is designed in accordance with the 2018 International Residential Code sections R502.11.1 and R802.10.2 and referenced standard ANSI/TPI 1.
- 12) Graphical purlin representation does not depict the size or the orientation of the purlin along the top and/or bottom chord.

- 13) "NAILED" indicates 3-10d (0.148"x3") or 3-12d (0.148"x3.25") toe-nails per NDS guidelines.
- 14) In the LOAD CASE(S) section, loads applied to the face of the truss are noted as front (F) or back (B).

LOAD CASE(S) Standard

- 1) Dead + Snow (balanced): Lumber Increase=1.15, Plate Increase=1.15
 Uniform Loads (lb/ft)
 Vert: 1-12=-60, 13-23=-20
 Concentrated Loads (lb)
 Vert: 1=-40 (F), 20=-28 (F), 3=-106 (F), 21=-28 (F), 6=-106 (F), 18=-28 (F), 16=-28 (F), 24=-106 (F), 25=-106 (F), 26=-106 (F), 27=-106 (F), 28=-106 (F), 29=-106 (F), 30=-106 (F), 31=-106 (F), 32=-106 (F), 33=-106 (F), 34=-106 (F), 35=-106 (F), 36=-106 (F), 37=-106 (F), 38=-106 (F), 39=-106 (F), 40=-106 (F), 41=-106 (F), 42=-106 (F), 43=-106 (F), 44=-28 (F), 45=-28 (F), 46=-28 (F), 47=-28 (F), 48=-28 (F), 49=-28 (F), 50=-28 (F), 51=-28 (F), 52=-28 (F), 53=-28 (F), 54=-28 (F), 55=-28 (F), 56=-28 (F), 57=-28 (F), 58=-28 (F), 59=-28 (F), 60=-28 (F), 61=-28 (F)



April 1, 2024

WARNING - Verify design parameters and READ NOTES ON THIS AND INCLUDED MITEK REFERENCE PAGE MII-7473 rev. 1/2/2023 BEFORE USE.

Design valid for use only with MITek® connectors. This design is based only upon parameters shown, and is for an individual building component, not a truss system. Before use, the building designer must verify the applicability of design parameters and properly incorporate this design into the overall building design. Bracing indicated is to prevent buckling of individual truss web and/or chord members only. Additional temporary and permanent bracing is always required for stability and to prevent collapse with possible personal injury and property damage. For general guidance regarding the fabrication, storage, delivery, erection and bracing of trusses and truss systems, see **ANSI/TPI Quality Criteria and DSB-22** available from Truss Plate Institute (www.tpinst.org) and **BCSI Building Component Safety Information** available from the Structural Building Component Association (www.sbcacomponents.com)



818 Soundside Road
 Edenton, NC 27932

Job 24030153-01	Truss A6	Truss Type Hip	Qty 1	Ply 1	142 Serenity-Roof-B329 B LH CP Job Reference (optional)	164576276
--------------------	-------------	-------------------	----------	----------	--	-----------

Carter Components (Sanford, NC), Sanford, NC - 27332,

Run: 9.03 S 8.73 Mar 21 2024 Print: 8.730 S Mar 21 2024 MiTek Industries, Inc. Fri Mar 29 10:41:37

Page: 1

Id: aU11ihHbkeL8g_Z2VekD8zMCBp-RfC?PsB70Hq3NSgPqnL8w3uITXbGKWrCDoi7J4zJC7f

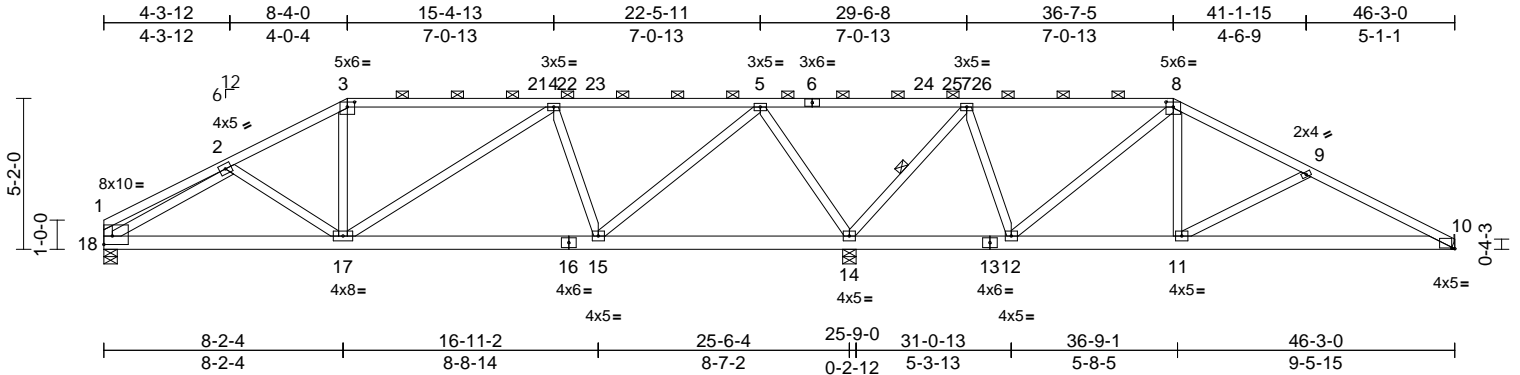

Scale = 1:78.9

Plate Offsets (X, Y): [1:Edge,0-3-8], [3:0-3-0,0-2-0], [8:0-3-0,0-2-0], [10:0-1-4,0-0-5]

Loading	(psf)	Spacing	2-0-0	CSI	DEFL	in (loc)	l/defl	L/d	PLATES	GRIP		
TCLL (roof)	20.0	Plate Grip DOL	1.15	TC	0.92	Vert(LL)	-0.06	11-20	>999	240	MT20	244/190
Snow (Pf)	20.0	Lumber DOL	1.15	BC	0.45	Vert(CT)	-0.14	11-20	>999	180		
TCDL	10.0	Rep Stress Incr	YES	WB	0.91	Horz(CT)	0.02	10	n/a	n/a		
BCLL	0.0*	Code	IRC2018/TPI2014	Matrix-MSH								
BCDL	10.0										Weight: 279 lb	FT = 20%

LUMBER
TOP CHORD 2x4 SP No.2 *Except* 6-8:2x4 SP No.1
BOT CHORD 2x6 SP No.2
WEBS 2x4 SP No.3

BRACING
TOP CHORD Structural wood sheathing directly applied or 4-9-8 oc purlins, except end verticals, and 2-0-0 oc purlins (2-2-0 max.): 3-8.
BOT CHORD Rigid ceiling directly applied or 6-0-0 oc bracing.
WEBS 1 Row at midpt 7-14

REACTIONS (size)
10= Mechanical, 14=0-5-8, 18=0-5-8
Max Horiz 18=-78 (LC 15)
Max Uplift 10=-117 (LC 15), 14=-258 (LC 10), 18=-135 (LC 14)
Max Grav 10=823 (LC 44), 14=2464 (LC 39), 18=966 (LC 42)

FORCES (lb) - Maximum Compression/Maximum Tension
TOP CHORD 1-2=-341/57, 2-3=-1102/214, 3-4=-977/219, 4-5=-702/171, 5-7=-72/1036, 7-8=-62/153, 8-9=-780/186, 9-10=-1267/259, 1-18=-297/65
BOT CHORD 17-18=-221/1118, 15-17=-130/903, 14-15=-357/133, 12-14=-242/132, 11-12=-22/579, 10-11=-171/1095
WEBS 2-17=-298/124, 3-17=0/248, 4-17=-16/348, 4-15=-696/197, 5-15=-125/1269, 5-14=-1431/258, 7-14=-1410/237, 7-12=-3/564, 8-12=-735/85, 8-11=0/479, 9-11=-568/170, 2-18=-1065/197

- Wind: ASCE 7-16; Vult=130mph (3-second gust) Vasd=103mph; TCDL=6.0psf; BCDL=6.0psf; h=25ft; Cat II; Exp B; Enclosed; MWFRS (envelope) exterior zone and C-C Exterior(2E) 0-1-12 to 4-9-4, Exterior(2R) 4-9-4 to 14-10-8, Interior (1) 14-10-8 to 30-0-13, Exterior(2R) 30-0-13 to 41-3-14, Exterior(2E) 41-3-14 to 46-2-4 zone; cantilever left and right exposed; end vertical left and right exposed; C-C for members and forces & MWFRS for reactions shown; Lumber DOL=1.60 plate grip DOL=1.60
- TCLL: ASCE 7-16; Pr=20.0 psf (roof LL: Lum DOL=1.15 Plate DOL=1.15); Pf=20.0 psf (Lum DOL=1.15 Plate DOL=1.15); Is=1.0; Rough Cat B; Fully Exp.; Ce=0.9; Cs=1.00; Ct=1.10
- Unbalanced snow loads have been considered for this design.
- Provide adequate drainage to prevent water ponding.
- This truss has been designed for a 10.0 psf bottom chord live load nonconcurrent with any other live loads.
- * This truss has been designed for a live load of 20.0psf on the bottom chord in all areas where a rectangle 3-06-00 tall by 2-00-00 wide will fit between the bottom chord and any other members.
- Refer to girder(s) for truss to truss connections.
- Provide mechanical connection (by others) of truss to bearing plate capable of withstanding 117 lb uplift at joint 10.
- One H2.5A Simpson Strong-Tie connectors recommended to connect truss to bearing walls due to UPLIFT at jt(s) 14 and 18. This connection is for uplift only and does not consider lateral forces.
- This truss is designed in accordance with the 2018 International Residential Code sections R502.11.1 and R802.10.2 and referenced standard ANSI/TPI 1.
- Graphical purlin representation does not depict the size or the orientation of the purlin along the top and/or bottom chord.

LOAD CASE(S) Standard



April 1, 2024

Job 24030153-01	Truss A5	Truss Type Hip	Qty 1	Ply 1	142 Serenity-Roof-B329 B LH CP Job Reference (optional)	164576277
--------------------	-------------	-------------------	----------	----------	--	-----------

Carter Components (Sanford, NC), Sanford, NC - 27332,

Run: 9.03 S 8.73 Mar 21 2024 Print: 8.730 S Mar 21 2024 MiTek Industries, Inc. Fri Mar 29 10:41:37

Page: 1

ID:E9GQhRE8mtRqfkVPk9TW5qzMCB5-RfC?PsB70Hq3NSgPqnL8w3ulTXbGKwRCDoi7J4zJC?f

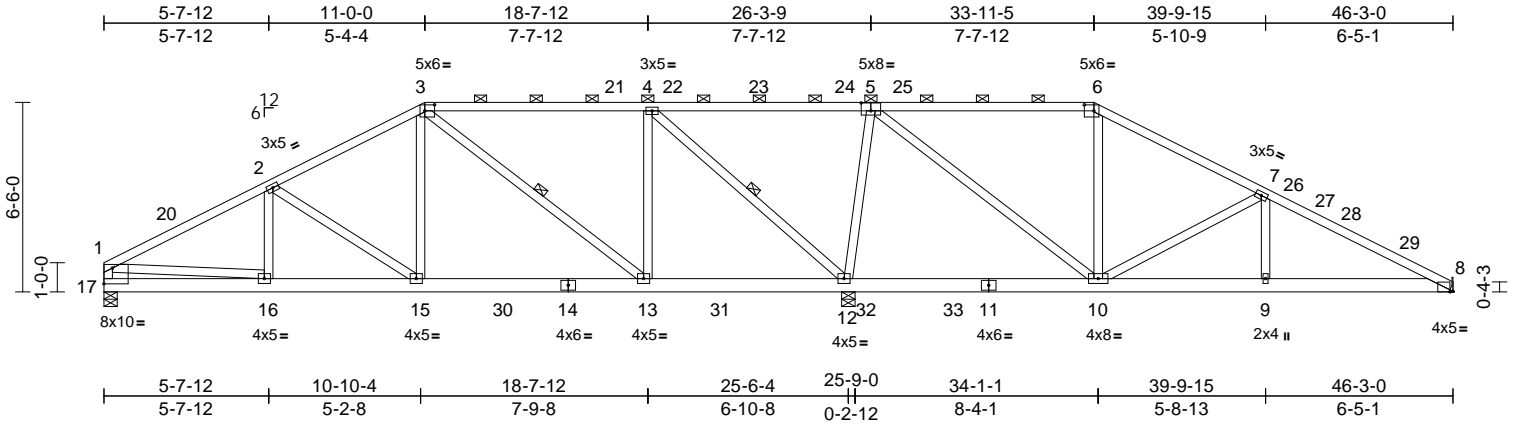

Scale = 1:79

Plate Offsets (X, Y): [3:0-4-0,0-2-8], [5:0-4-0,0-3-4], [6:0-4-0,0-2-8], [8:0-1-4,0-0-3], [17:Edge,0-6-8]

Loading	(psf)	Spacing	2-0-0	CSI	DEFL	in	(loc)	l/defl	L/d	PLATES	GRIP	
TCLL (roof)	20.0	Plate Grip DOL	1.15	TC	0.82	Vert(LL)	-0.06	13-15	>999	240	MT20	244/190
Snow (Pf)	20.0	Lumber DOL	1.15	BC	0.52	Vert(CT)	-0.11	13-15	>999	180		
TCDL	10.0	Rep Stress Incr	YES	WB	0.96	Horz(CT)	0.02	8	n/a	n/a		
BCLL	0.0*	Code	IRC2018/TPI2014	Matrix-MSH								
BCDL	10.0											
											Weight: 292 lb	FT = 20%

LUMBER

TOP CHORD 2x4 SP No.2 *Except* 3-5,5-6:2x4 SP No.1
 BOT CHORD 2x6 SP No.2
 WEBS 2x4 SP No.3

BRACING

TOP CHORD Structural wood sheathing directly applied or 4-0-15 oc purlins, except end verticals, and 2-0-0 oc purlins (4-11-7 max.): 3-6.
 BOT CHORD Rigid ceiling directly applied or 10-0-0 oc bracing, Except:
 6-0-0 oc bracing: 10-12.
 WEBS 1 Row at midpt 3-13, 4-12

REACTIONS

(size) 8= Mechanical, 12=0-5-8, 17=0-5-8
 Max Horiz 17=100 (LC 15)
 Max Uplift 8=114 (LC 15), 12=188 (LC 10), 17=134 (LC 14)
 Max Grav 8=821 (LC 44), 12=2591 (LC 45), 17=1076 (LC 36)

FORCES

(lb) - Maximum Compression/Maximum Tension
 TOP CHORD 1-2=-1541/217, 2-3=-1144/217, 3-4=-576/171, 4-6=-391/834, 6-7=-575/165, 7-8=-1377/218, 1-17=-981/161
 BOT CHORD 16-17=-119/310, 15-16=-207/1304, 13-15=-99/934, 12-13=-77/577, 10-12=-747/178, 9-10=-120/1154, 8-9=-120/1154
 WEBS 2-16=-51/113, 2-15=-553/129, 3-15=0/589, 3-13=-739/77, 4-13=0/731, 4-12=-1794/224, 5-12=-1353/271, 5-10=-127/1352, 6-10=-275/101, 7-10=-876/184, 7-9=0/265, 1-16=-88/1014

NOTES

1) Unbalanced roof live loads have been considered for this design.

- Wind: ASCE 7-16; Vult=130mph (3-second gust) Vasd=103mph; TCDL=6.0psf; BCDL=6.0psf; h=25ft; Cat II; Exp B; Enclosed; MWFRS (envelope) exterior zone and C-C Exterior(2E) 0-1-12 to 4-9-4, Exterior(2R) 4-9-4 to 17-6-8, Interior (1) 17-6-8 to 27-4-13, Exterior(2R) 27-4-13 to 40-5-13, Interior (1) 40-5-13 to 41-6-12, Exterior(2E) 41-6-12 to 46-2-4 zone; cantilever left and right exposed; end vertical left and right exposed; C-C for members and forces & MWFRS for reactions shown; Lumber DOL=1.60 plate grip DOL=1.60
- TCLL: ASCE 7-16; Pr=20.0 psf (roof LL: Lum DOL=1.15 Plate DOL=1.15); Pf=20.0 psf (Lum DOL=1.15 Plate DOL=1.15); Is=1.0; Rough Cat B; Fully Exp.; Ce=0.9; Cs=1.00; Ct=1.10
- Unbalanced snow loads have been considered for this design.
- Provide adequate drainage to prevent water ponding.
- This truss has been designed for a 10.0 psf bottom chord live load nonconcurrent with any other live loads.
- * This truss has been designed for a live load of 20.0psf on the bottom chord in all areas where a rectangle 3-06-00 tall by 2-00-00 wide will fit between the bottom chord and any other members, with BCDL = 10.0psf.
- Refer to girder(s) for truss to truss connections.
- Provide mechanical connection (by others) of truss to bearing plate capable of withstanding 114 lb uplift at joint 8.
- One H2.5A Simpson Strong-Tie connectors recommended to connect truss to bearing walls due to UPLIFT at jt(s) 17 and 12. This connection is for uplift only and does not consider lateral forces.
- This truss is designed in accordance with the 2018 International Residential Code sections R502.11.1 and R802.10.2 and referenced standard ANSI/TPI 1.
- Graphical purlin representation does not depict the size or the orientation of the purlin along the top and/or bottom chord.

LOAD CASE(S) Standard



April 1, 2024

WARNING - Verify design parameters and READ NOTES ON THIS AND INCLUDED MITEK REFERENCE PAGE MII-7473 rev. 1/2/2023 BEFORE USE.

Design valid for use only with MiTek® connectors. This design is based only upon parameters shown, and is for an individual building component, not a truss system. Before use, the building designer must verify the applicability of design parameters and properly incorporate this design into the overall building design. Bracing indicated is to prevent buckling of individual truss web and/or chord members only. Additional temporary and permanent bracing is always required for stability and to prevent collapse with possible personal injury and property damage. For general guidance regarding the fabrication, storage, delivery, erection and bracing of trusses and truss systems, see **ANSI/TPI Quality Criteria and DSB-22** available from Truss Plate Institute (www.tpinst.org) and **BCSI Building Component Safety Information** available from the Structural Building Component Association (www.sbcacomponents.com)



818 Soundside Road
 Edenton, NC 27932

Job 24030153-01	Truss JGE	Truss Type Jack-Open Supported Gable	Qty 1	Ply 1	142 Serenity-Roof-B329 B LH CP Job Reference (optional)	164576278
--------------------	--------------	---	----------	----------	--	-----------

Carter Components (Sanford, NC), Sanford, NC - 27332,

Run: 9.03 S 8.73 Mar 21 2024 Print: 8.730 S Mar 21 2024 MiTek Industries, Inc. Fri Mar 29 10:41:43

Page: 1

ID:h1JzkGRc6CdZENXOp8NkJzMCJt-RfC?PsB70Hq3NSgPqnL8w3ulTXbGKwRCDoi7J4zJC7f

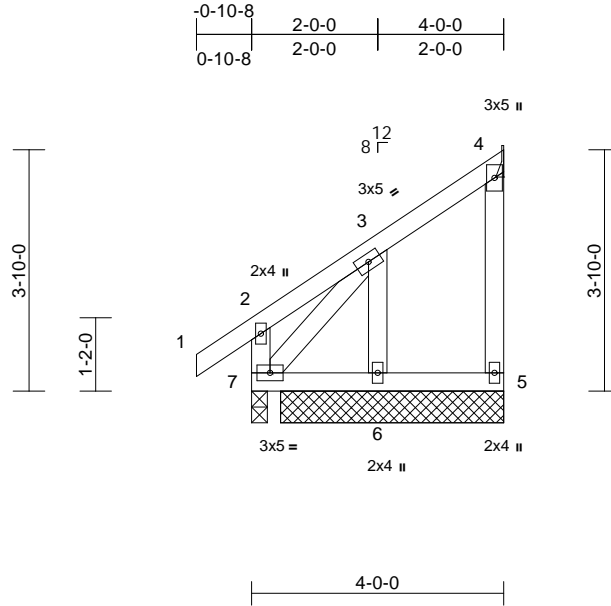

Loading	(psf)	Spacing	2-0-0	CSI	DEFL	in	(loc)	l/defl	L/d	PLATES	GRIP
TCLL (roof)	20.0	Plate Grip DOL	1.15	TC	0.23	Vert(LL)	0.00	6-7	>999	240	244/190
Snow (Pf)	20.0	Lumber DOL	1.15	BC	0.03	Vert(CT)	0.00	6-7	>999	180	
TCDL	10.0	Rep Stress Incr	YES	WB	0.08	Horz(CT)	0.00	4	n/a	n/a	
BCLL	0.0*	Code	IRC2018/TPI2014	Matrix-MP							
BCDL	10.0									Weight: 27 lb	FT = 20%

LUMBER

TOP CHORD	2x4 SP No.2
BOT CHORD	2x4 SP No.2
WEBS	2x4 SP No.3
OTHERS	2x4 SP No.3

BRACING

TOP CHORD	Structural wood sheathing directly applied or 4-0-0 oc purlins, except end verticals.
BOT CHORD	Rigid ceiling directly applied or 10-0-0 oc bracing.

REACTIONS (size)

4= Mechanical, 5=3-6-8, 6=3-6-8, 7=0-3-0
Max Horiz 7=131 (LC 13)
Max Uplift 4=-31 (LC 11), 6=-90 (LC 14), 7=-25 (LC 10)
Max Grav 4=78 (LC 21), 5=28 (LC 7), 6=234 (LC 21), 7=222 (LC 21)

FORCES (lb) - Maximum Compression/Maximum Tension

TOP CHORD	2-7=-208/248, 1-2=0/57, 2-3=-59/147, 3-4=-74/97, 4-5=0/0
BOT CHORD	6-7=-44/79, 5-6=-44/79
WEBS	3-6=-236/277, 3-7=-275/213

- NOTES**
- Wind: ASCE 7-16; Vult=130mph (3-second gust) Vasd=103mph; TCDL=6.0psf; BCDL=6.0psf; h=25ft; Cat. II; Exp B; Enclosed; MWFRS (envelope) exterior zone and C-C Corner(3E) zone; cantilever left and right exposed; end vertical left and right exposed; C-C for members and forces & MWFRS for reactions shown; Lumber DOL=1.60 plate grip DOL=1.60
 - Truss designed for wind loads in the plane of the truss only. For studs exposed to wind (normal to the face), see Standard Industry Gable End Details as applicable, or consult qualified building designer as per ANSI/TPI 1.

- TCLL: ASCE 7-16; Pr=20.0 psf (roof LL: Lum DOL=1.15 Plate DOL=1.15); Pf=20.0 psf (Lum DOL=1.15 Plate DOL=1.15); Is=1.0; Rough Cat B; Fully Exp.; Ce=0.9; Cs=1.00; Ct=1.10
 - Unbalanced snow loads have been considered for this design.
 - This truss has been designed for greater of min roof live load of 12.0 psf or 1.00 times flat roof load of 20.0 psf on overhangs non-concurrent with other live loads.
 - Truss to be fully sheathed from one face or securely braced against lateral movement (i.e. diagonal web).
 - Gable studs spaced at 2-0-0 oc.
 - This truss has been designed for a 10.0 psf bottom chord live load nonconcurrent with any other live loads.
 - * This truss has been designed for a live load of 20.0psf on the bottom chord in all areas where a rectangle 3-06-00 tall by 2-00-00 wide will fit between the bottom chord and any other members.
 - Refer to girder(s) for truss to truss connections.
 - Provide mechanical connection (by others) of truss to bearing plate capable of withstanding 31 lb uplift at joint 4.
 - One H2.5A Simpson Strong-Tie connectors recommended to connect truss to bearing walls due to UPLIFT at joint 7. This connection is for uplift only and does not consider lateral forces.
 - This truss is designed in accordance with the 2018 International Residential Code sections R502.11.1 and R802.10.2 and referenced standard ANSI/TPI 1.
 - Gap between inside of top chord bearing and first diagonal or vertical web shall not exceed 0.500in.
- LOAD CASE(S)** Standard



April 1, 2024

WARNING - Verify design parameters and READ NOTES ON THIS AND INCLUDED MITEK REFERENCE PAGE MII-7473 rev. 1/2/2023 BEFORE USE.

Design valid for use only with MiTek® connectors. This design is based only upon parameters shown, and is for an individual building component, not a truss system. Before use, the building designer must verify the applicability of design parameters and properly incorporate this design into the overall building design. Bracing indicated is to prevent buckling of individual truss web and/or chord members only. Additional temporary and permanent bracing is always required for stability and to prevent collapse with possible personal injury and property damage. For general guidance regarding the fabrication, storage, delivery, erection and bracing of trusses and truss systems, see **ANSI/TPI Quality Criteria and DSB-22** available from Truss Plate Institute (www.tpinst.org) and **BCSI Building Component Safety Information** available from the Structural Building Component Association (www.sbcacomponents.com)



818 Soundside Road
Edenton, NC 27932

Job 24030153-01	Truss J	Truss Type Jack-Open	Qty 22	Ply 1	142 Serenity-Roof-B329 B LH CP Job Reference (optional)	164576279
--------------------	------------	-------------------------	-----------	----------	--	-----------

Carter Components (Sanford, NC), Sanford, NC - 27332,

Run: 9.03 S 8.73 Mar 21 2024 Print: 8.730 S Mar 21 2024 MiTek Industries, Inc. Fri Mar 29 10:41:42

Page: 1

ID:PyvlqhZumGu8RvLJPEZ4jQzMCJj-RfC?PsB70Hq3NSgPqnL8w3ulTXbGKwRCDoi7J4zJC?f

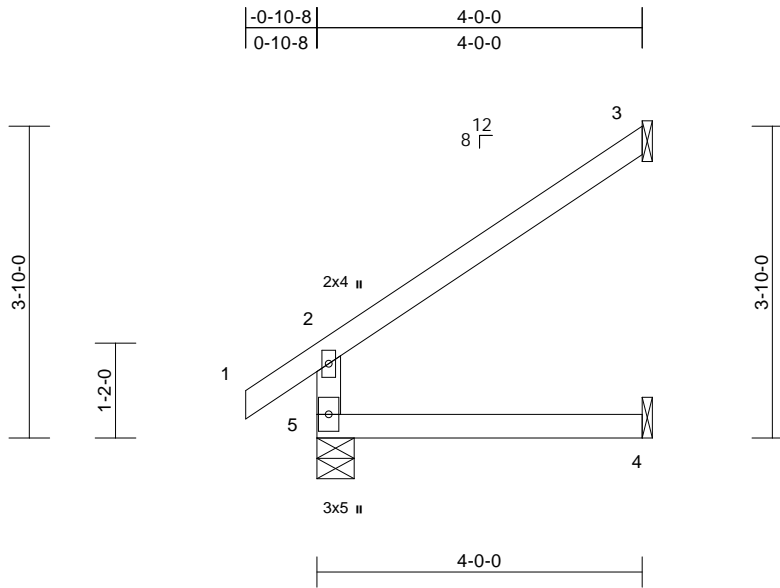

Scale = 1:28.3

Loading	(psf)	Spacing	2-0-0	CSI	DEFL	in	(loc)	l/defl	L/d	PLATES	GRIP	
TCLL (roof)	20.0	Plate Grip DOL	1.15	TC	0.35	Vert(LL)	0.02	4-5	>999	240	MT20	244/190
Snow (Pf)	20.0	Lumber DOL	1.15	BC	0.22	Vert(CT)	-0.02	4-5	>999	180		
TCDL	10.0	Rep Stress Incr	YES	WB	0.00	Horz(CT)	-0.03	3	n/a	n/a		
BCLL	0.0*	Code	IRC2018/TPI2014	Matrix-MR								
BCDL	10.0											
											Weight: 16 lb	FT = 20%

LUMBER

TOP CHORD 2x4 SP No.2
BOT CHORD 2x4 SP No.2
WEBS 2x4 SP No.3

BRACING

TOP CHORD Structural wood sheathing directly applied or 4-0-0 oc purlins, except end verticals.
BOT CHORD Rigid ceiling directly applied or 10-0-0 oc bracing.

REACTIONS (size) 3= Mechanical, 4= Mechanical,
5=0-5-8
Max Horiz 5=102 (LC 14)
Max Uplift 3=-78 (LC 14)
Max Grav 3=166 (LC 21), 4=72 (LC 7), 5=345 (LC 21)

FORCES (lb) - Maximum Compression/Maximum Tension

TOP CHORD 2-5=-317/95, 1-2=0/57, 2-3=-119/71
BOT CHORD 4-5=0/0

NOTES

- 1) Wind: ASCE 7-16; Vult=130mph (3-second gust)
Vasd=103mph; TCDL=6.0psf; BCDL=6.0psf; h=25ft; Cat. II; Exp B; Enclosed; MWFRS (envelope) exterior zone and C-C Exterior(2E) zone; cantilever left and right exposed; end vertical left and right exposed; C-C for members and forces & MWFRS for reactions shown; Lumber DOL=1.60 plate grip DOL=1.60
- 2) TCLL: ASCE 7-16; Pr=20.0 psf (roof LL: Lum DOL=1.15 Plate DOL=1.15); Pf=20.0 psf (Lum DOL=1.15 Plate DOL=1.15); Is=1.0; Rough Cat B; Fully Exp.; Ce=0.9; Cs=1.00; Ct=1.10
- 3) Unbalanced snow loads have been considered for this design.
- 4) This truss has been designed for greater of min roof live load of 12.0 psf or 1.00 times flat roof load of 20.0 psf on overhangs non-concurrent with other live loads.
- 5) This truss has been designed for a 10.0 psf bottom chord live load nonconcurrent with any other live loads.

- 6) * This truss has been designed for a live load of 20.0psf on the bottom chord in all areas where a rectangle 3-06-00 tall by 2-00-00 wide will fit between the bottom chord and any other members.
 - 7) Bearings are assumed to be: , Joint 5 User Defined .
 - 8) Refer to girder(s) for truss to truss connections.
 - 9) Provide mechanical connection (by others) of truss to bearing plate capable of withstanding 78 lb uplift at joint 3.
 - 10) This truss is designed in accordance with the 2018 International Residential Code sections R502.11.1 and R802.10.2 and referenced standard ANSI/TPI 1.
- LOAD CASE(S)** Standard



April 1, 2024

WARNING - Verify design parameters and READ NOTES ON THIS AND INCLUDED MITEK REFERENCE PAGE MII-7473 rev. 1/2/2023 BEFORE USE.

Design valid for use only with MiTek® connectors. This design is based only upon parameters shown, and is for an individual building component, not a truss system. Before use, the building designer must verify the applicability of design parameters and properly incorporate this design into the overall building design. Bracing indicated is to prevent buckling of individual truss web and/or chord members only. Additional temporary and permanent bracing is always required for stability and to prevent collapse with possible personal injury and property damage. For general guidance regarding the fabrication, storage, delivery, erection and bracing of trusses and truss systems, see **ANSI/TPI1 Quality Criteria and DSB-22** available from Truss Plate Institute (www.tpinst.org) and **BCSI Building Component Safety Information** available from the Structural Building Component Association (www.sbcacomponents.com)

ENGINEERING BY
TRENCO
A MiTek Affiliate

818 Soundside Road
Edenton, NC 27932

Job 24030153-01	Truss V11	Truss Type Valley	Qty 1	Ply 1	142 Serenity-Roof-B329 B LH CP Job Reference (optional)	164576280
--------------------	--------------	----------------------	----------	----------	--	-----------

Carter Components (Sanford, NC), Sanford, NC - 27332,

Run: 9.03 S 8.73 Mar 21 2024 Print: 8.730 S Mar 21 2024 MiTek Industries, Inc. Fri Mar 29 10:41:44
ID: _I7EHwldzD88zBqL8B4OKKzMDB?-RfC?PsB70Hq3NSgPqnL8w3uITXbGKwRCdoi7J4zJC7f

Page: 1

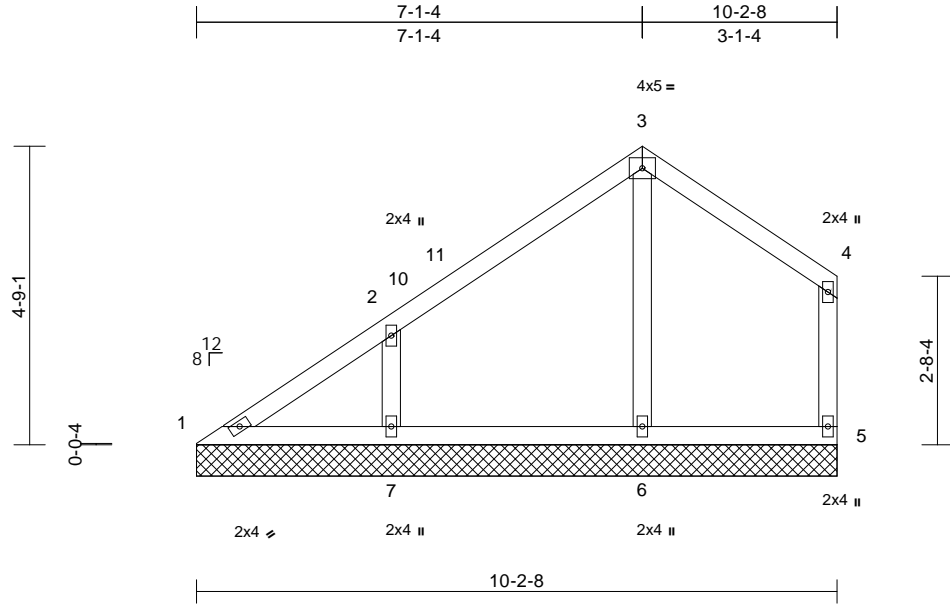

Scale = 1:36.7

Loading	(psf)	Spacing	2-0-0	CSI	DEFL	in	(loc)	l/defl	L/d	PLATES	GRIP	
TCLL (roof)	20.0	Plate Grip DOL	1.15	TC	0.29	Vert(LL)	n/a	-	n/a	999	MT20	244/190
Snow (Pf)	20.0	Lumber DOL	1.15	BC	0.10	Vert(TL)	n/a	-	n/a	999		
TCDL	10.0	Rep Stress Incr	YES	WB	0.09	Horiz(TL)	0.00	5	n/a	n/a		
BCLL	0.0*	Code	IRC2018/TPI2014	Matrix-MSH								
BCDL	10.0											
										Weight: 45 lb	FT = 20%	

LUMBER
TOP CHORD 2x4 SP No.2
BOT CHORD 2x4 SP No.2
WEBS 2x4 SP No.3
OTHERS 2x4 SP No.3

BRACING
TOP CHORD Structural wood sheathing directly applied or 6-0-0 oc purlins, except end verticals.
BOT CHORD Rigid ceiling directly applied or 10-0-0 oc bracing.

REACTIONS (size)
1=10-2-8, 5=10-2-8, 6=10-2-8, 7=10-2-8
Max Horiz 1=138 (LC 11)
Max Uplift 1=-19 (LC 10), 5=-39 (LC 15), 7=-118 (LC 14)
Max Grav 1=120 (LC 30), 5=182 (LC 21), 6=296 (LC 20), 7=401 (LC 20)

FORCES (lb) - Maximum Compression/Maximum Tension
TOP CHORD 1-2=-170/119, 2-3=-133/109, 3-4=-101/117, 4-5=-158/100
BOT CHORD 1-7=-32/139, 6-7=-30/43, 5-6=-30/43
WEBS 3-6=-235/47, 2-7=-322/191

NOTES
1) Unbalanced roof live loads have been considered for this design.
2) Wind: ASCE 7-16; Vult=130mph (3-second gust) Vasd=103mph; TCDL=6.0psf; BCDL=6.0psf; h=25ft; Cat. II; Exp B; Enclosed; MWFRS (envelope) exterior zone and C-C Exterior(2E) 0-0-6 to 3-1-10, Interior (1) 3-1-10 to 4-1-10, Exterior(2R) 4-1-10 to 7-1-10, Exterior(2E) 7-1-10 to 10-1-2 zone; cantilever left and right exposed; end vertical left and right exposed; C-C for members and forces & MWFRS for reactions shown; Lumber DOL=1.60 plate grip DOL=1.60

- Truss designed for wind loads in the plane of the truss only. For studs exposed to wind (normal to the face), see Standard Industry Gable End Details as applicable, or consult qualified building designer as per ANSI/TPI 1.
- TCLL: ASCE 7-16; Pr=20.0 psf (roof LL: Lum DOL=1.15 Plate DOL=1.15); Pf=20.0 psf (Lum DOL=1.15 Plate DOL=1.15); Is=1.0; Rough Cat B; Fully Exp.; Ce=0.9; Cs=1.00; Ct=1.10
- Unbalanced snow loads have been considered for this design.
- Gable requires continuous bottom chord bearing.
- Gable studs spaced at 4-0-0 oc.
- This truss has been designed for a 10.0 psf bottom chord live load nonconcurrent with any other live loads.
- * This truss has been designed for a live load of 20.0psf on the bottom chord in all areas where a rectangle 3-06-00 tall by 2-00-00 wide will fit between the bottom chord and any other members.
- Provide mechanical connection (by others) of truss to bearing plate capable of withstanding 39 lb uplift at joint 5, 19 lb uplift at joint 1 and 118 lb uplift at joint 7.
- This truss is designed in accordance with the 2018 International Residential Code sections R502.11.1 and R802.10.2 and referenced standard ANSI/TPI 1.

LOAD CASE(S) Standard



April 1, 2024

WARNING - Verify design parameters and READ NOTES ON THIS AND INCLUDED MITEK REFERENCE PAGE MII-7473 rev. 1/2/2023 BEFORE USE.

Design valid for use only with MiTek® connectors. This design is based only upon parameters shown, and is for an individual building component, not a truss system. Before use, the building designer must verify the applicability of design parameters and properly incorporate this design into the overall building design. Bracing indicated is to prevent buckling of individual truss web and/or chord members only. Additional temporary and permanent bracing is always required for stability and to prevent collapse with possible personal injury and property damage. For general guidance regarding the fabrication, storage, delivery, erection and bracing of trusses and truss systems, see **ANSI/TPI1 Quality Criteria and DSB-22** available from Truss Plate Institute (www.tpinst.org) and **BCSI Building Component Safety Information** available from the Structural Building Component Association (www.sbcacomponents.com)

ENGINEERING BY
TRENCO
A MiTek Affiliate

818 Soundside Road
Edenton, NC 27932

Job 24030153-01	Truss V12	Truss Type Valley	Qty 1	Ply 1	142 Serenity-Roof-B329 B LH CP Job Reference (optional)	164576281
--------------------	--------------	----------------------	----------	----------	--	-----------

Carter Components (Sanford, NC), Sanford, NC - 27332,

Run: 9.03 S 8.73 Mar 21 2024 Print: 8.730 S Mar 21 2024 MiTek Industries, Inc. Fri Mar 29 10:41:44
ID:Hf3tJq0JN09JGsh29i26pzMDAu-RfC?PsB70Hq3NSgPqnL8w3uITXbGKWrCDoi7J4zJC?f

Page: 1

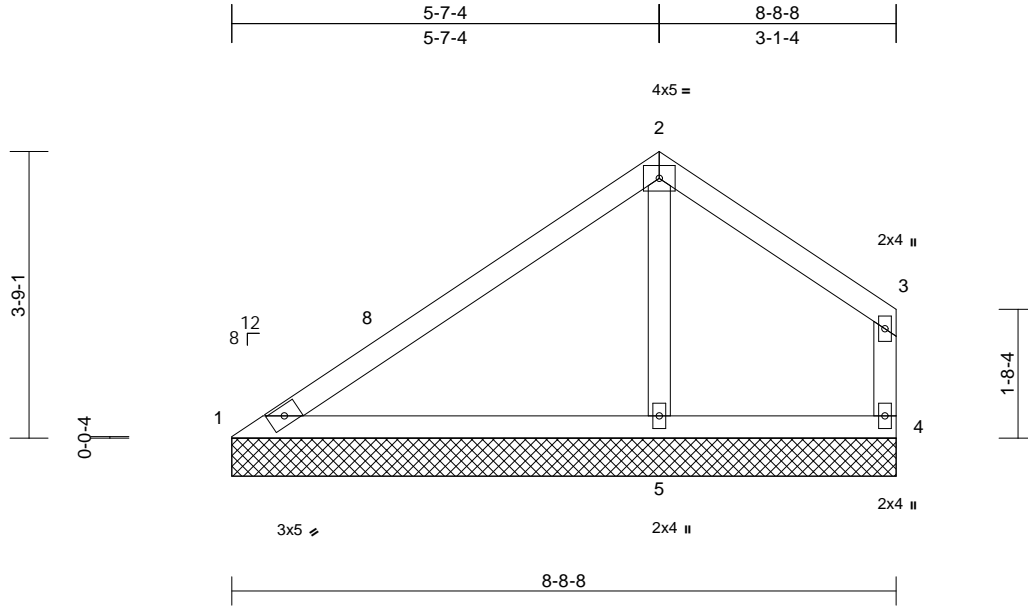

Loading	(psf)	Spacing	2-0-0	CSI	DEFL	in	(loc)	l/defl	L/d	PLATES	GRIP	
TCLL (roof)	20.0	Plate Grip DOL	1.15	TC	0.58	Vert(LL)	n/a	-	n/a	999	MT20	244/190
Snow (Pf)	20.0	Lumber DOL	1.15	BC	0.61	Vert(TL)	n/a	-	n/a	999		
TCDL	10.0	Rep Stress Incr	YES	WB	0.07	Horiz(TL)	0.01	4	n/a	n/a		
BCLL	0.0*	Code	IRC2018/TPI2014	Matrix-MP								
BCDL	10.0											
										Weight: 34 lb	FT = 20%	

LUMBER
TOP CHORD 2x4 SP No.2
BOT CHORD 2x4 SP No.2
WEBS 2x4 SP No.3
OTHERS 2x4 SP No.3

BRACING
TOP CHORD Structural wood sheathing directly applied or 6-0-0 oc purlins, except end verticals.
BOT CHORD Rigid ceiling directly applied or 10-0-0 oc bracing.

REACTIONS (size) 1=8-8-8, 4=8-8-8, 5=8-8-8
Max Horiz 1=102 (LC 11)
Max Uplift 1=-26 (LC 14), 4=-40 (LC 15), 5=-22 (LC 14)
Max Grav 1=236 (LC 20), 4=151 (LC 21), 5=449 (LC 20)

FORCES (lb) - Maximum Compression/Maximum Tension
TOP CHORD 1-2=-332/108, 2-3=-66/96, 3-4=-149/99
BOT CHORD 1-5=-105/310, 4-5=-19/27
WEBS 2-5=-262/39

- NOTES**
- 1) Unbalanced roof live loads have been considered for this design.
 - 2) Wind: ASCE 7-16; Vult=130mph (3-second gust) Vasd=103mph; TCDL=6.0psf; BCDL=6.0psf; h=25ft; Cat. II; Exp B; Enclosed; MWFRS (envelope) exterior zone and C-C Exterior(2E) 0-0-6 to 3-0-6, Exterior(2R) 3-0-6 to 5-7-10, Exterior(2E) 5-7-10 to 8-7-2 zone; cantilever left and right exposed; end vertical left and right exposed; C-C for members and forces & MWFRS for reactions shown; Lumber DOL=1.60 plate grip DOL=1.60
 - 3) Truss designed for wind loads in the plane of the truss only. For studs exposed to wind (normal to the face), see Standard Industry Gable End Details as applicable, or consult qualified building designer as per ANSI/TPI 1.

- 4) TCLL: ASCE 7-16; Pr=20.0 psf (roof LL: Lum DOL=1.15 Plate DOL=1.15); Pf=20.0 psf (Lum DOL=1.15 Plate DOL=1.15); Is=1.0; Rough Cat B; Fully Exp.; Ce=0.9; Cs=1.00; Ct=1.10
- 5) Unbalanced snow loads have been considered for this design.
- 6) Gable requires continuous bottom chord bearing.
- 7) Gable studs spaced at 4-0-0 oc.
- 8) This truss has been designed for a 10.0 psf bottom chord live load nonconcurrent with any other live loads.
- 9) * This truss has been designed for a live load of 20.0psf on the bottom chord in all areas where a rectangle 3-06-00 tall by 2-00-00 wide will fit between the bottom chord and any other members.
- 10) Provide mechanical connection (by others) of truss to bearing plate capable of withstanding 40 lb uplift at joint 4, 26 lb uplift at joint 1 and 22 lb uplift at joint 5.
- 11) This truss is designed in accordance with the 2018 International Residential Code sections R502.11.1 and R802.10.2 and referenced standard ANSI/TPI 1.

LOAD CASE(S) Standard

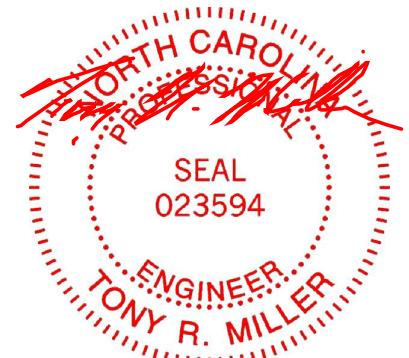

April 1, 2024

WARNING - Verify design parameters and READ NOTES ON THIS AND INCLUDED MITEK REFERENCE PAGE MII-7473 rev. 1/2/2023 BEFORE USE.

Design valid for use only with MiTek® connectors. This design is based only upon parameters shown, and is for an individual building component, not a truss system. Before use, the building designer must verify the applicability of design parameters and properly incorporate this design into the overall building design. Bracing indicated is to prevent buckling of individual truss web and/or chord members only. Additional temporary and permanent bracing is always required for stability and to prevent collapse with possible personal injury and property damage. For general guidance regarding the fabrication, storage, delivery, erection and bracing of trusses and truss systems, see **ANSI/TPI1 Quality Criteria and DSB-22** available from Truss Plate Institute (www.tpinst.org) and **BCSI Building Component Safety Information** available from the Structural Building Component Association (www.sbcacomponents.com)

ENGINEERING BY
TRENCO
A MiTek Affiliate

818 Soundside Road
Edenton, NC 27932

Job 24030153-01	Truss V13	Truss Type Valley	Qty 1	Ply 1	142 Serenity-Roof-B329 B LH CP Job Reference (optional)	I64576282
--------------------	--------------	----------------------	----------	----------	--	-----------

Carter Components (Sanford, NC), Sanford, NC - 27332,

Run: 9.03 S 8.73 Mar 21 2024 Print: 8.730 S Mar 21 2024 MiTek Industries, Inc. Fri Mar 29 10:41:44
ID:a?_XDivPgWv9flU1y7KhuHzMDAn-RfC?PsB70Hq3NSgPqnL8w3uITXbGKwRCDoi7J4zJC?

Page: 1

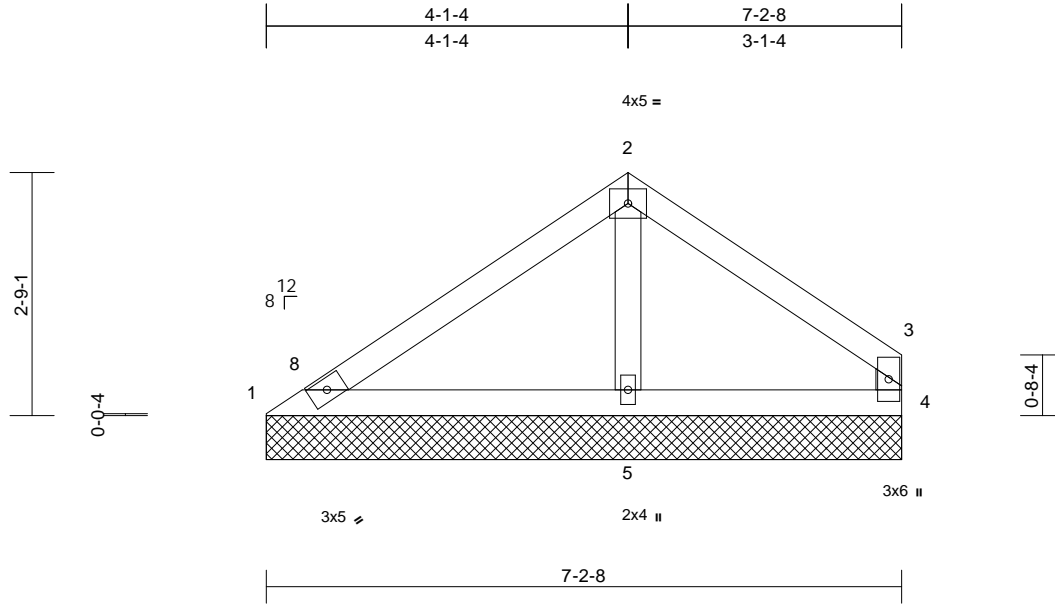

Scale = 1:26.1

Loading	(psf)	Spacing	2-0-0	CSI	DEFL	in	(loc)	l/defl	L/d	PLATES	GRIP	
TCLL (roof)	20.0	Plate Grip DOL	1.15	TC	0.29	Vert(LL)	n/a	-	n/a	999	MT20	244/190
Snow (Pf)	20.0	Lumber DOL	1.15	BC	0.36	Vert(TL)	n/a	-	n/a	999		
TCDL	10.0	Rep Stress Incr	YES	WB	0.04	Horiz(TL)	0.00	4	n/a	n/a		
BCLL	0.0*	Code	IRC2018/TPI2014	Matrix-MP								
BCDL	10.0											
										Weight: 27 lb	FT = 20%	

LUMBER

TOP CHORD	2x4 SP No.2
BOT CHORD	2x4 SP No.2
WEBS	2x4 SP No.3
OTHERS	2x4 SP No.3

BRACING

TOP CHORD	Structural wood sheathing directly applied or 7-2-8 oc purlins, except end verticals.
BOT CHORD	Rigid ceiling directly applied or 10-0-0 oc bracing.

REACTIONS

(size)	1=7-2-8, 4=7-2-8, 5=7-2-8
Max Horiz	1=66 (LC 11)
Max Uplift	1=-24 (LC 14), 4=-43 (LC 15), 5=-8 (LC 14)
Max Grav	1=195 (LC 20), 4=158 (LC 21), 5=351 (LC 20)

FORCES

(lb) - Maximum Compression/Maximum Tension	
TOP CHORD	1-2=-272/112, 2-3=-64/79, 3-4=-144/97
BOT CHORD	1-5=-98/224, 4-5=-6/9
WEBS	2-5=-200/38

NOTES

- 1) Unbalanced roof live loads have been considered for this design.
- 2) Wind: ASCE 7-16; Vult=130mph (3-second gust) Vasd=103mph; TCDL=6.0psf; BCDL=6.0psf; h=25ft; Cat. II; Exp B; Enclosed; MWFRS (envelope) exterior zone and C-C Exterior(2E) 0-0-6 to 3-0-6, Exterior(2R) 3-0-6 to 4-1-10, Exterior(2E) 4-1-10 to 7-1-2 zone; cantilever left and right exposed; end vertical left and right exposed; C-C for members and forces & MWFRS for reactions shown; Lumber DOL=1.60 plate grip DOL=1.60
- 3) Truss designed for wind loads in the plane of the truss only. For studs exposed to wind (normal to the face), see Standard Industry Gable End Details as applicable, or consult qualified building designer as per ANSI/TPI 1.

- 4) TCLL: ASCE 7-16; Pr=20.0 psf (roof LL: Lum DOL=1.15 Plate DOL=1.15); Pf=20.0 psf (Lum DOL=1.15 Plate DOL=1.15); Is=1.0; Rough Cat B; Fully Exp.; Ce=0.9; Cs=1.00; Ct=1.10
- 5) Unbalanced snow loads have been considered for this design.
- 6) Gable requires continuous bottom chord bearing.
- 7) Gable studs spaced at 4-0-0 oc.
- 8) This truss has been designed for a 10.0 psf bottom chord live load nonconcurrent with any other live loads.
- 9) * This truss has been designed for a live load of 20.0psf on the bottom chord in all areas where a rectangle 3-06-00 tall by 2-00-00 wide will fit between the bottom chord and any other members.
- 10) Provide mechanical connection (by others) of truss to bearing plate capable of withstanding 43 lb uplift at joint 4, 24 lb uplift at joint 1 and 8 lb uplift at joint 5.
- 11) This truss is designed in accordance with the 2018 International Residential Code sections R502.11.1 and R802.10.2 and referenced standard ANSI/TPI 1.

LOAD CASE(S) Standard



April 1, 2024

WARNING - Verify design parameters and READ NOTES ON THIS AND INCLUDED MITEK REFERENCE PAGE MII-7473 rev. 1/2/2023 BEFORE USE.

Design valid for use only with MiTek® connectors. This design is based only upon parameters shown, and is for an individual building component, not a truss system. Before use, the building designer must verify the applicability of design parameters and properly incorporate this design into the overall building design. Bracing indicated is to prevent buckling of individual truss web and/or chord members only. Additional temporary and permanent bracing is always required for stability and to prevent collapse with possible personal injury and property damage. For general guidance regarding the fabrication, storage, delivery, erection and bracing of trusses and truss systems, see **ANSI/TPI1 Quality Criteria and DSB-22** available from Truss Plate Institute (www.tpinst.org) and **BCSI Building Component Safety Information** available from the Structural Building Component Association (www.sbcacomponents.com)

ENGINEERING BY
TRENCO
A MiTek Affiliate

818 Soundside Road
Edenton, NC 27932

Job 24030153-01	Truss V1	Truss Type Valley	Qty 1	Ply 1	142 Serenity-Roof-B329 B LH CP Job Reference (optional)	164576284
--------------------	-------------	----------------------	----------	----------	--	-----------

Carter Components (Sanford, NC), Sanford, NC - 27332,

Run: 9.03 S 8.73 Mar 21 2024 Print: 8.730 S Mar 21 2024 MiTek Industries, Inc. Fri Mar 29 10:41:43
ID: ?rB5QY9yygQK2Qr7KhNiVzMDAT-RfC?PsB70Hq3NSgPqnl8w3uTXbGKwRcDoi7J4zJC?f

Page: 1

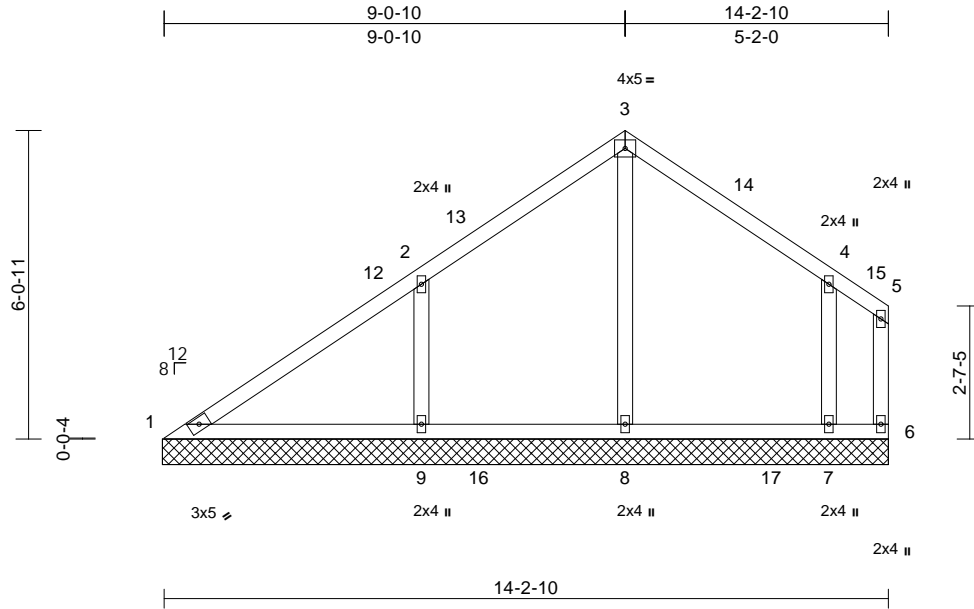

Loading	(psf)	Spacing	2-0-0	CSI	DEFL	in	(loc)	l/defl	L/d	PLATES	GRIP	
TCLL (roof)	20.0	Plate Grip DOL	1.15	TC	0.38	Vert(LL)	n/a	-	n/a	999	MT20	244/190
Snow (Pf)	20.0	Lumber DOL	1.15	BC	0.25	Vert(TL)	n/a	-	n/a	999		
TCDL	10.0	Rep Stress Incr	YES	WB	0.16	Horiz(TL)	0.00	9	n/a	n/a		
BCLL	0.0*	Code	IRC2018/TPI2014	Matrix-MSH								
BCDL	10.0											
											Weight: 66 lb	FT = 20%

LUMBER
 TOP CHORD 2x4 SP No.2
 BOT CHORD 2x4 SP No.2
 WEBS 2x4 SP No.3
 OTHERS 2x4 SP No.3

BRACING
 TOP CHORD Structural wood sheathing directly applied or 6-0-0 oc purlins, except end verticals.
 BOT CHORD Rigid ceiling directly applied or 6-0-0 oc bracing.

REACTIONS (size)
 1=14-3-0, 6=14-3-0, 7=14-3-0, 8=14-3-0, 9=14-3-0
 Max Horiz 1=167 (LC 11)
 Max Uplift 1=11 (LC 10), 6=135 (LC 6), 7=131 (LC 15), 9=157 (LC 14)
 Max Grav 1=196 (LC 25), 6=46 (LC 15), 7=501 (LC 21), 8=412 (LC 24), 9=564 (LC 5)

FORCES (lb) - Maximum Compression/Maximum Tension
 TOP CHORD 1-2=-299/179, 2-3=-129/148, 3-4=-118/147, 4-5=-44/115, 5-6=-52/111
 BOT CHORD 1-9=-49/262, 8-9=-38/50, 7-8=-38/50, 6-7=-38/50
 WEBS 3-8=-246/34, 2-9=-429/192, 4-7=-419/172

NOTES
 1) Unbalanced roof live loads have been considered for this design.
 2) Wind: ASCE 7-16; Vult=130mph (3-second gust) Vasd=103mph; TCDL=6.0psf; BCDL=6.0psf; h=25ft; Cat. II; Exp B; Enclosed; MWFRS (envelope) exterior zone and C-C Exterior(2E) 0-0-0 to 3-0-0, Interior (1) 3-0-0 to 6-1-0, Exterior(2R) 6-1-0 to 11-1-4, Exterior(2E) 11-1-4 to 14-1-4 zone; cantilever left and right exposed; end vertical left and right exposed; C-C for members and forces & MWFRS for reactions shown; Lumber DOL=1.60 plate grip DOL=1.60

- Truss designed for wind loads in the plane of the truss only. For studs exposed to wind (normal to the face), see Standard Industry Gable End Details as applicable, or consult qualified building designer as per ANSI/TPI 1.
- TCLL: ASCE 7-16; Pr=20.0 psf (roof LL: Lum DOL=1.15 Plate DOL=1.15); Pf=20.0 psf (Lum DOL=1.15 Plate DOL=1.15); Is=1.0; Rough Cat B; Fully Exp.; Ce=0.9; Cs=1.00; Ct=1.10
- Unbalanced snow loads have been considered for this design.
- Gable requires continuous bottom chord bearing.
- Gable studs spaced at 4-0-0 oc.
- This truss has been designed for a 10.0 psf bottom chord live load nonconcurrent with any other live loads.
- * This truss has been designed for a live load of 20.0psf on the bottom chord in all areas where a rectangle 3-06-00 tall by 2-00-00 wide will fit between the bottom chord and any other members, with BCDL = 10.0psf.
- Provide mechanical connection (by others) of truss to bearing plate capable of withstanding 135 lb uplift at joint 6, 11 lb uplift at joint 1, 157 lb uplift at joint 9 and 131 lb uplift at joint 7.
- Beveled plate or shim required to provide full bearing surface with truss chord at joint(s) 1.
- This truss is designed in accordance with the 2018 International Residential Code sections R502.11.1 and R802.10.2 and referenced standard ANSI/TPI 1.

LOAD CASE(S) Standard



April 1, 2024

WARNING - Verify design parameters and READ NOTES ON THIS AND INCLUDED MITEK REFERENCE PAGE MII-7473 rev. 1/2/2023 BEFORE USE.

Design valid for use only with MiTek® connectors. This design is based only upon parameters shown, and is for an individual building component, not a truss system. Before use, the building designer must verify the applicability of design parameters and properly incorporate this design into the overall building design. Bracing indicated is to prevent buckling of individual truss web and/or chord members only. Additional temporary and permanent bracing is always required for stability and to prevent collapse with possible personal injury and property damage. For general guidance regarding the fabrication, storage, delivery, erection and bracing of trusses and truss systems, see **ANSI/TPI Quality Criteria and DSB-22** available from Truss Plate Institute (www.tpinst.org) and **BCSI Building Component Safety Information** available from the Structural Building Component Association (www.sbcacomponents.com)

ENGINEERING BY
TRENCO
 A MiTek Affiliate

818 Soundside Road
 Edenton, NC 27932

Job 24030153-01	Truss V2	Truss Type Valley	Qty 1	Ply 1	142 Serenity-Roof-B329 B LH CP Job Reference (optional)	164576285
--------------------	-------------	----------------------	----------	----------	--	-----------

Carter Components (Sanford, NC), Sanford, NC - 27332,

Run: 9.03 S 8.73 Mar 21 2024 Print: 8.730 S Mar 21 2024 MiTek Industries, Inc. Fri Mar 29 10:41:43

Page: 1

ID:EaEUJdGqRZ2eoc9jMUZPzMDAK-RfC?PsB70Hq3NSgPqnL8w3uITXbGKwCDoi7J4zJC?f

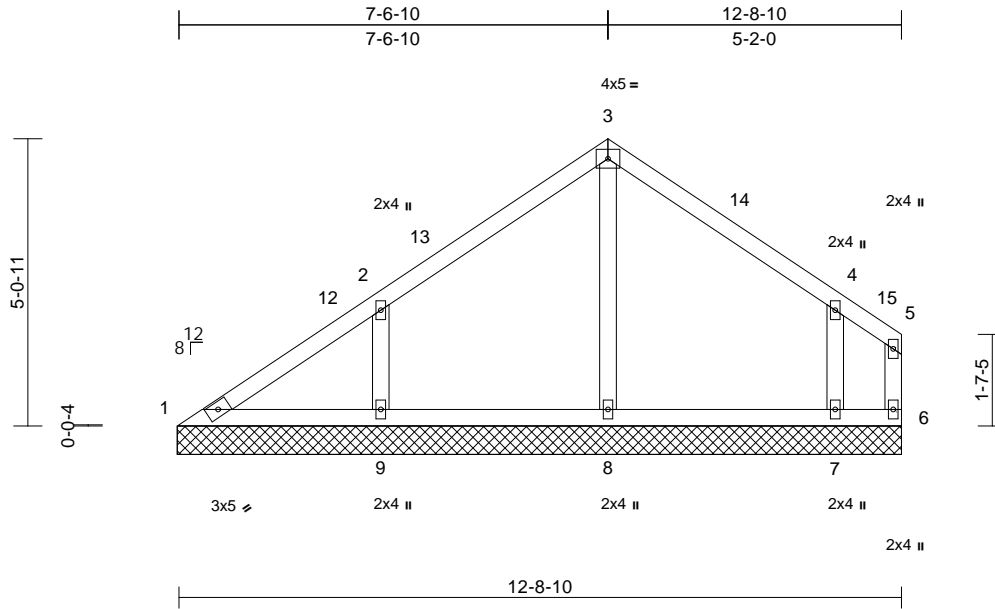

Scale = 1:40.6

Loading	(psf)	Spacing	2-0-0	CSI	DEFL	in	(loc)	l/defl	L/d	PLATES	GRIP	
TCLL (roof)	20.0	Plate Grip DOL	1.15	TC	0.32	Vert(LL)	n/a	-	n/a	999	MT20	244/190
Snow (Pf)	20.0	Lumber DOL	1.15	BC	0.11	Vert(TL)	n/a	-	n/a	999		
TCDL	10.0	Rep Stress Incr	YES	WB	0.11	Horiz(TL)	0.00	9	n/a	n/a		
BCLL	0.0*	Code	IRC2018/TPI2014	Matrix-MSH								
BCDL	10.0											
										Weight: 55 lb	FT = 20%	

LUMBER
TOP CHORD 2x4 SP No.2
BOT CHORD 2x4 SP No.2
WEBS 2x4 SP No.3
OTHERS 2x4 SP No.3

BRACING
TOP CHORD Structural wood sheathing directly applied or 6-0-0 oc purlins, except end verticals.
BOT CHORD Rigid ceiling directly applied or 6-0-0 oc bracing.

REACTIONS (size)
1=12-9-0, 6=12-9-0, 7=12-9-0, 8=12-9-0, 9=12-9-0
Max Horiz 1=131 (LC 11)
Max Uplift 1=-17 (LC 10), 6=-121 (LC 21), 7=-139 (LC 15), 9=-127 (LC 14)
Max Grav 1=127 (LC 25), 6=53 (LC 15), 7=488 (LC 21), 8=332 (LC 21), 9=479 (LC 20)

FORCES (lb) - Maximum Compression/Maximum Tension
TOP CHORD 1-2=-183/139, 2-3=-124/125, 3-4=-118/125, 4-5=-46/113, 5-6=-55/110
BOT CHORD 1-9=-31/142, 8-9=-31/36, 7-8=-31/36, 6-7=-31/36
WEBS 3-8=-252/20, 2-9=-390/167, 4-7=-418/175

NOTES
1) Unbalanced roof live loads have been considered for this design.
2) Wind: ASCE 7-16; Vult=130mph (3-second gust) Vasd=103mph; TCDL=6.0psf; BCDL=6.0psf; h=25ft; Cat. II; Exp B; Enclosed; MWFRS (envelope) exterior zone and C-C Exterior(2E) 0-0-0 to 3-0-0, Interior (1) 3-0-0 to 4-7-0, Exterior(2R) 4-7-0 to 9-7-4, Exterior(2E) 9-7-4 to 12-7-4 zone; cantilever left and right exposed; end vertical left and right exposed; C-C for members and forces & MWFRS for reactions shown; Lumber DOL=1.60 plate grip DOL=1.60

- Truss designed for wind loads in the plane of the truss only. For studs exposed to wind (normal to the face), see Standard Industry Gable End Details as applicable, or consult qualified building designer as per ANSI/TPI 1.
- TCLL: ASCE 7-16; Pr=20.0 psf (roof LL: Lum DOL=1.15 Plate DOL=1.15); Pf=20.0 psf (Lum DOL=1.15 Plate DOL=1.15); Is=1.0; Rough Cat B; Fully Exp.; Ce=0.9; Cs=1.00; Ct=1.10
- Unbalanced snow loads have been considered for this design.
- Gable requires continuous bottom chord bearing.
- Gable studs spaced at 4-0-0 oc.
- This truss has been designed for a 10.0 psf bottom chord live load nonconcurrent with any other live loads.
- * This truss has been designed for a live load of 20.0psf on the bottom chord in all areas where a rectangle 3-06-00 tall by 2-00-00 wide will fit between the bottom chord and any other members.
- Provide mechanical connection (by others) of truss to bearing plate capable of withstanding 121 lb uplift at joint 6, 17 lb uplift at joint 1, 127 lb uplift at joint 9 and 139 lb uplift at joint 7.
- Beveled plate or shim required to provide full bearing surface with truss chord at joint(s) 1.
- This truss is designed in accordance with the 2018 International Residential Code sections R502.11.1 and R802.10.2 and referenced standard ANSI/TPI 1.

LOAD CASE(S) Standard



April 1, 2024

WARNING - Verify design parameters and READ NOTES ON THIS AND INCLUDED MITEK REFERENCE PAGE MII-7473 rev. 1/2/2023 BEFORE USE.

Design valid for use only with MiTek® connectors. This design is based only upon parameters shown, and is for an individual building component, not a truss system. Before use, the building designer must verify the applicability of design parameters and properly incorporate this design into the overall building design. Bracing indicated is to prevent buckling of individual truss web and/or chord members only. Additional temporary and permanent bracing is always required for stability and to prevent collapse with possible personal injury and property damage. For general guidance regarding the fabrication, storage, delivery, erection and bracing of trusses and truss systems, see **ANSI/TPI1 Quality Criteria and DSB-22** available from Truss Plate Institute (www.tpinst.org) and **BCSI Building Component Safety Information** available from the Structural Building Component Association (www.sbcacomponents.com)

ENGINEERING BY
TRENCO
A MiTek Affiliate

818 Soundside Road
Edenton, NC 27932

Job 24030153-01	Truss V3	Truss Type Valley	Qty 1	Ply 1	142 Serenity-Roof-B329 B LH CP Job Reference (optional)	164576286
--------------------	-------------	----------------------	----------	----------	--	-----------

Carter Components (Sanford, NC), Sanford, NC - 27332,

Run: 9.03 S 8.73 Mar 21 2024 Print: 8.730 S Mar 21 2024 MiTek Industries, Inc. Fri Mar 29 10:41:43
ID:eQR2VTv87a4C1t8SKwjANdzMDA0-RfC?PsB70Hq3NSgPqnL8w3uITXbGKWrCDoi7J4zJC?f

Page: 1

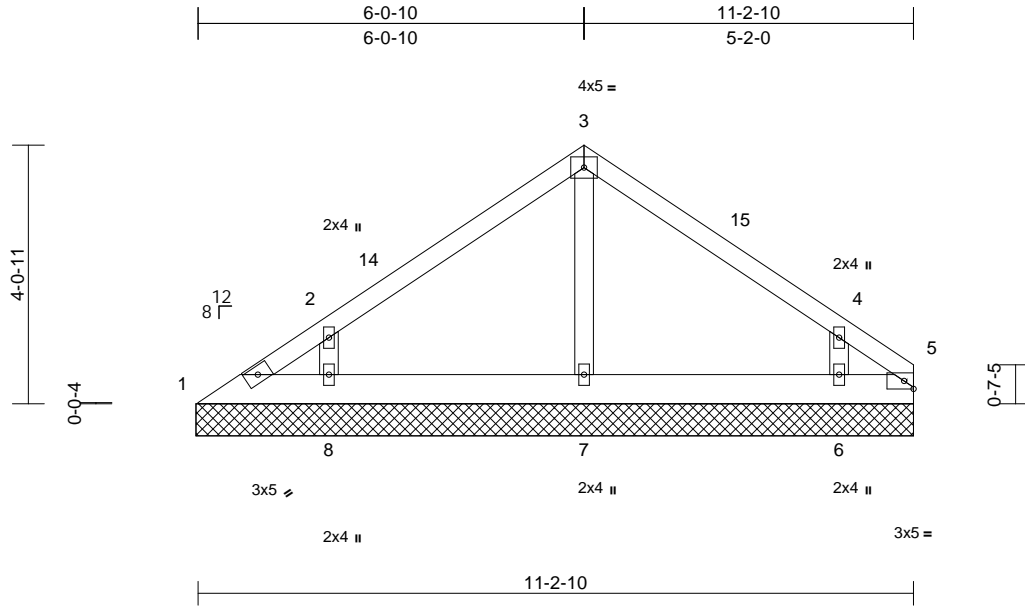

Scale = 1:36.1

Loading	(psf)	Spacing	2-0-0	CSI	DEFL	in	(loc)	l/defl	L/d	PLATES	GRIP	
TCLL (roof)	20.0	Plate Grip DOL	1.15	TC	0.32	Vert(LL)	n/a	-	n/a	999	MT20	244/190
Snow (Pf)	20.0	Lumber DOL	1.15	BC	0.06	Vert(TL)	n/a	-	n/a	999		
TCDL	10.0	Rep Stress Incr	YES	WB	0.09	Horiz(TL)	0.00	5	n/a	n/a		
BCLL	0.0*	Code	IRC2018/TPI2014	Matrix-MSH								
BCDL	10.0											
										Weight: 52 lb	FT = 20%	

LUMBER

TOP CHORD 2x4 SP No.2
BOT CHORD 2x6 SP No.2
OTHERS 2x4 SP No.3

BRACING

TOP CHORD Structural wood sheathing directly applied or 6-0-0 oc purlins.
BOT CHORD Rigid ceiling directly applied or 10-0-0 oc bracing.

REACTIONS

(size) 1=11-3-0, 5=11-3-0, 6=11-3-0, 7=11-3-0, 8=11-3-0, 9=11-3-0
Max Horiz 1=90 (LC 11)
Max Uplift 1=-14 (LC 10), 5=-50 (LC 13), 6=-131 (LC 15), 8=-107 (LC 14), 9=-50 (LC 13)
Max Grav 1=69 (LC 25), 5=64 (LC 15), 6=459 (LC 21), 7=284 (LC 21), 8=452 (LC 20), 9=64 (LC 15)

FORCES

(lb) - Maximum Compression/Maximum Tension

TOP CHORD 1-2=-96/81, 2-3=-180/75, 3-4=-171/75, 4-5=-90/88
BOT CHORD 1-8=-37/69, 7-8=-23/58, 6-7=-23/58, 5-6=-24/58
WEBS 3-7=-196/39, 2-8=-457/201, 4-6=-466/205

NOTES

- Unbalanced roof live loads have been considered for this design.
- Wind: ASCE 7-16; Vult=130mph (3-second gust) Vasd=103mph; TCDL=6.0psf; BCDL=6.0psf; h=25ft; Cat. II; Exp B; Enclosed; MWFRS (envelope) exterior zone and C-C Exterior(2E) 0-0-0 to 3-0-0, Exterior(2R) 3-0-0 to 8-3-0, Exterior(2E) 8-3-0 to 11-3-0 zone; cantilever left and right exposed ;C-C for members and forces & MWFRS for reactions shown; Lumber DOL=1.60 plate grip DOL=1.60

- Truss designed for wind loads in the plane of the truss only. For studs exposed to wind (normal to the face), see Standard Industry Gable End Details as applicable, or consult qualified building designer as per ANSI/TPI 1.
- TCLL: ASCE 7-16; Pr=20.0 psf (roof LL: Lum DOL=1.15 Plate DOL=1.15); Pf=20.0 psf (Lum DOL=1.15 Plate DOL=1.15); Is=1.0; Rough Cat B; Fully Exp.; Ce=0.9; Cs=1.00; Ct=1.10
- Unbalanced snow loads have been considered for this design.
- Gable requires continuous bottom chord bearing.
- Gable studs spaced at 4-0-0 oc.
- This truss has been designed for a 10.0 psf bottom chord live load nonconcurrent with any other live loads.
- * This truss has been designed for a live load of 20.0psf on the bottom chord in all areas where a rectangle 3-06-00 tall by 2-00-00 wide will fit between the bottom chord and any other members.
- Provide mechanical connection (by others) of truss to bearing plate capable of withstanding 50 lb uplift at joint 5, 14 lb uplift at joint 1, 107 lb uplift at joint 8, 131 lb uplift at joint 6 and 50 lb uplift at joint 5.
- Beveled plate or shim required to provide full bearing surface with truss chord at joint(s) 1.
- This truss is designed in accordance with the 2018 International Residential Code sections R502.11.1 and R802.10.2 and referenced standard ANSI/TPI 1.

LOAD CASE(S) Standard



April 1, 2024

WARNING - Verify design parameters and READ NOTES ON THIS AND INCLUDED MITEK REFERENCE PAGE MII-7473 rev. 1/2/2023 BEFORE USE.

Design valid for use only with MiTek® connectors. This design is based only upon parameters shown, and is for an individual building component, not a truss system. Before use, the building designer must verify the applicability of design parameters and properly incorporate this design into the overall building design. Bracing indicated is to prevent buckling of individual truss web and/or chord members only. Additional temporary and permanent bracing is always required for stability and to prevent collapse with possible personal injury and property damage. For general guidance regarding the fabrication, storage, delivery, erection and bracing of trusses and truss systems, see **ANSI/TPI Quality Criteria and DSB-22** available from Truss Plate Institute (www.tpinst.org) and **BCSI Building Component Safety Information** available from the Structural Building Component Association (www.sbcacomponents.com)



818 Soundside Road
Edenton, NC 27932

Job 24030153-01	Truss V5	Truss Type Valley	Qty 1	Ply 1	142 Serenity-Roof-B329 B LH CP Job Reference (optional)	164576288
--------------------	-------------	----------------------	----------	----------	--	-----------

Carter Components (Sanford, NC), Sanford, NC - 27332,

Run: 9.03 S 8.73 Mar 21 2024 Print: 8.730 S Mar 21 2024 MiTek Industries, Inc. Fri Mar 29 10:41:43

Page: 1

ID:AVP5xiBMV5xyKNXGH?w1?zMD9m-RFC?PsB70Hq3NSgPqnL8w3uITXbGKWRcDoi7J4zJC?f

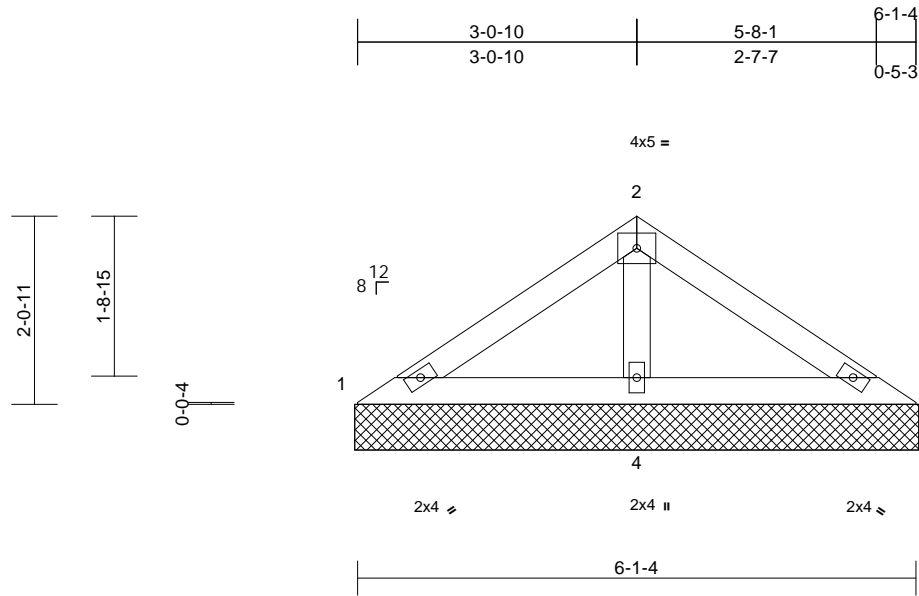

Loading	(psf)	Spacing	2-0-0	CSI	DEFL	in	(loc)	l/defl	L/d	PLATES	GRIP	
TCLL (roof)	20.0	Plate Grip DOL	1.15	TC	0.15	Vert(LL)	n/a	-	n/a	999	MT20	244/190
Snow (Pf)	20.0	Lumber DOL	1.15	BC	0.17	Vert(TL)	n/a	-	n/a	999		
TCDL	10.0	Rep Stress Incr	YES	WB	0.06	Horiz(TL)	0.00	4	n/a	n/a		
BCLL	0.0*	Code	IRC2018/TPI2014	Matrix-MP								
BCDL	10.0										Weight: 21 lb	FT = 20%

LUMBER
TOP CHORD 2x4 SP No.2
BOT CHORD 2x4 SP No.2
OTHERS 2x4 SP No.3

BRACING
TOP CHORD Structural wood sheathing directly applied or 6-1-4 oc purlins.
BOT CHORD Rigid ceiling directly applied or 6-0-0 oc bracing.

REACTIONS (size) 1=6-2-0, 3=6-2-0, 4=6-2-0
Max Horiz 1=-44 (LC 10)
Max Uplift 1=-3 (LC 14), 3=-10 (LC 15), 4=-39 (LC 14)
Max Grav 1=97 (LC 20), 3=97 (LC 21), 4=406 (LC 20)

FORCES (lb) - Maximum Compression/Maximum Tension
TOP CHORD 1-2=-96/173, 2-3=-96/173
BOT CHORD 1-4=-149/109, 3-4=-149/109
WEBS 2-4=-312/137

- Unbalanced snow loads have been considered for this design.
 - Gable requires continuous bottom chord bearing.
 - Gable studs spaced at 4-0-0 oc.
 - This truss has been designed for a 10.0 psf bottom chord live load nonconcurrent with any other live loads.
 - * This truss has been designed for a live load of 20.0psf on the bottom chord in all areas where a rectangle 3-06-00 tall by 2-00-00 wide will fit between the bottom chord and any other members.
 - Provide mechanical connection (by others) of truss to bearing plate capable of withstanding 3 lb uplift at joint 1, 10 lb uplift at joint 3 and 39 lb uplift at joint 4.
 - Beveled plate or shim required to provide full bearing surface with truss chord at joint(s) 1, 3.
 - This truss is designed in accordance with the 2018 International Residential Code sections R502.11.1 and R802.10.2 and referenced standard ANSI/TPI 1.
- LOAD CASE(S)** Standard

- NOTES**
- Unbalanced roof live loads have been considered for this design.
 - Wind: ASCE 7-16; Vult=130mph (3-second gust) Vasd=103mph; TCDL=6.0psf; BCDL=6.0psf; h=25ft; Cat. II; Exp B; Enclosed; MWFRS (envelope) exterior zone and C-C Exterior(2E) zone; cantilever left and right exposed ; end vertical left and right exposed;C-C for members and forces & MWFRS for reactions shown; Lumber DOL=1.60 plate grip DOL=1.60
 - Truss designed for wind loads in the plane of the truss only. For studs exposed to wind (normal to the face), see Standard Industry Gable End Details as applicable, or consult qualified building designer as per ANSI/TPI 1.
 - TCLL: ASCE 7-16; Pr=20.0 psf (roof LL: Lum DOL=1.15 Plate DOL=1.15); Pf=20.0 psf (Lum DOL=1.15 Plate DOL=1.15); Is=1.0; Rough Cat B; Fully Exp.; Ce=0.9; Cs=1.00; Ct=1.10



April 1, 2024

WARNING - Verify design parameters and READ NOTES ON THIS AND INCLUDED MITEK REFERENCE PAGE MII-7473 rev. 1/2/2023 BEFORE USE.

Design valid for use only with MiTek® connectors. This design is based only upon parameters shown, and is for an individual building component, not a truss system. Before use, the building designer must verify the applicability of design parameters and properly incorporate this design into the overall building design. Bracing indicated is to prevent buckling of individual truss web and/or chord members only. Additional temporary and permanent bracing is always required for stability and to prevent collapse with possible personal injury and property damage. For general guidance regarding the fabrication, storage, delivery, erection and bracing of trusses and truss systems, see **ANSI/TPI Quality Criteria and DSB-22** available from Truss Plate Institute (www.tpinst.org) and **BCSI Building Component Safety Information** available from the Structural Building Component Association (www.sbcacomponents.com)

ENGINEERING BY
TRENCO
A MiTek Affiliate

818 Soundside Road
Edenton, NC 27932

Job	Truss	Truss Type	Qty	Ply	142 Serenity-Roof-B329 B LH CP	I64576289
24030153-01	V6	Valley	1	1	Job Reference (optional)	

Carter Components (Sanford, NC), Sanford, NC - 27332,

Run: 9.03 S 8.73 Mar 21 2024 Print: 8.730 S Mar 21 2024 MiTek Industries, Inc. Fri Mar 29 10:41:43
ID: ?fmN7_mxxLr4gFqgdY6KGGzMD9g-RfC?PsB70Hq3NSgPqnL8w3uTXbGKWrCDoi7J4zJC?f

Page: 1

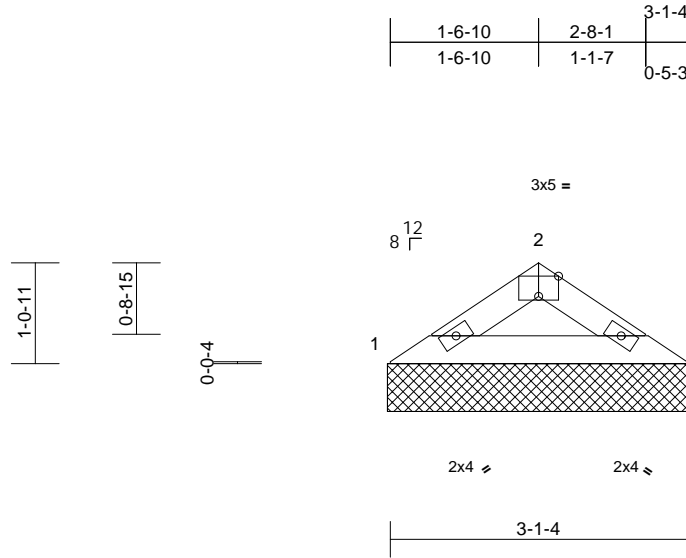

Scale = 1:24.1

Plate Offsets (X, Y): [2:0-2-8,Edge]

Loading	(psf)	Spacing	2-0-0	CSI	DEFL	in	(loc)	l/defl	L/d	PLATES	GRIP	
TCLL (roof)	20.0	Plate Grip DOL	1.15	TC	0.08	Vert(LL)	n/a	-	n/a	999	MT20	244/190
Snow (Pf)	20.0	Lumber DOL	1.15	BC	0.08	Vert(TL)	n/a	-	n/a	999		
TCDL	10.0	Rep Stress Incr	YES	WB	0.00	Horiz(TL)	0.00	3	n/a	n/a		
BCLL	0.0*	Code	IRC2018/TPI2014	Matrix-MP								
BCDL	10.0											
										Weight: 9 lb	FT = 20%	

LUMBER

TOP CHORD 2x4 SP No.2
BOT CHORD 2x4 SP No.2

BRACING

TOP CHORD Structural wood sheathing directly applied or 3-1-4 oc purlins.
BOT CHORD Rigid ceiling directly applied or 10-0-0 oc bracing.

REACTIONS

(size) 1=3-2-0, 3=3-2-0
Max Horiz 1=-21 (LC 12)
Max Uplift 1=-12 (LC 14), 3=-12 (LC 15)
Max Grav 1=143 (LC 20), 3=143 (LC 21)

FORCES

(lb) - Maximum Compression/Maximum Tension

TOP CHORD 1-2=-213/77, 2-3=-213/77
BOT CHORD 1-3=-52/170

NOTES

- Unbalanced roof live loads have been considered for this design.
- Wind: ASCE 7-16; Vult=130mph (3-second gust) Vasd=103mph; TCDL=6.0psf; BCDL=6.0psf; h=25ft; Cat. II; Exp B; Enclosed; MWFRS (envelope) exterior zone and C-C Exterior(2E) zone; cantilever left and right exposed; end vertical left and right exposed; C-C for members and forces & MWFRS for reactions shown; Lumber DOL=1.60 plate grip DOL=1.60
- Truss designed for wind loads in the plane of the truss only. For studs exposed to wind (normal to the face), see Standard Industry Gable End Details as applicable, or consult qualified building designer as per ANSI/TPI 1.
- TCLL: ASCE 7-16; Pr=20.0 psf (roof LL: Lum DOL=1.15 Plate DOL=1.15); Pf=20.0 psf (Lum DOL=1.15 Plate DOL=1.15); Is=1.0; Rough Cat B; Fully Exp.; Ce=0.9; Cs=1.00; Ct=1.10
- Unbalanced snow loads have been considered for this design.
- Gable requires continuous bottom chord bearing.

- Gable studs spaced at 4-0-0 oc.
- This truss has been designed for a 10.0 psf bottom chord live load nonconcurrent with any other live loads.
- * This truss has been designed for a live load of 20.0psf on the bottom chord in all areas where a rectangle 3-06-00 tall by 2-00-00 wide will fit between the bottom chord and any other members.
- Provide mechanical connection (by others) of truss to bearing plate capable of withstanding 12 lb uplift at joint 1 and 12 lb uplift at joint 3.
- Beveled plate or shim required to provide full bearing surface with truss chord at joint(s) 1, 3.
- This truss is designed in accordance with the 2018 International Residential Code sections R502.11.1 and R802.10.2 and referenced standard ANSI/TPI 1.

LOAD CASE(S) Standard



April 1, 2024

WARNING - Verify design parameters and READ NOTES ON THIS AND INCLUDED MITEK REFERENCE PAGE MII-7473 rev. 1/2/2023 BEFORE USE.

Design valid for use only with MiTek® connectors. This design is based only upon parameters shown, and is for an individual building component, not a truss system. Before use, the building designer must verify the applicability of design parameters and properly incorporate this design into the overall building design. Bracing indicated is to prevent buckling of individual truss web and/or chord members only. Additional temporary and permanent bracing is always required for stability and to prevent collapse with possible personal injury and property damage. For general guidance regarding the fabrication, storage, delivery, erection and bracing of trusses and truss systems, see **ANSI/TPI1 Quality Criteria and DSB-22** available from Truss Plate Institute (www.tpinst.org) and **BCSI Building Component Safety Information** available from the Structural Building Component Association (www.sbcacomponents.com)

ENGINEERING BY
TRENCO
A MiTek Affiliate

818 Soundside Road
Edenton, NC 27932

Job	Truss	Truss Type	Qty	Ply	142 Serenity-Roof-B329 B LH CP	164576290
24030153-01	PB1	Piggyback	9	1	Job Reference (optional)	

Carter Components (Sanford, NC), Sanford, NC - 27332,

Run: 9.03 S 8.73 Mar 21 2024 Print: 8.730 S Mar 21 2024 MiTek Industries, Inc. Fri Mar 29 10:41:43
ID:ksn03tXW0Suqz7L58mmLnzMDIQ-RFC?PsB70Hq3NSgPqnL8w3uITXbGKWrCDoi7J4zJC?f

Page: 1

-0-11-1	1-6-1	3-0-3	3-11-4
0-11-1	1-6-1	1-6-1	0-11-1

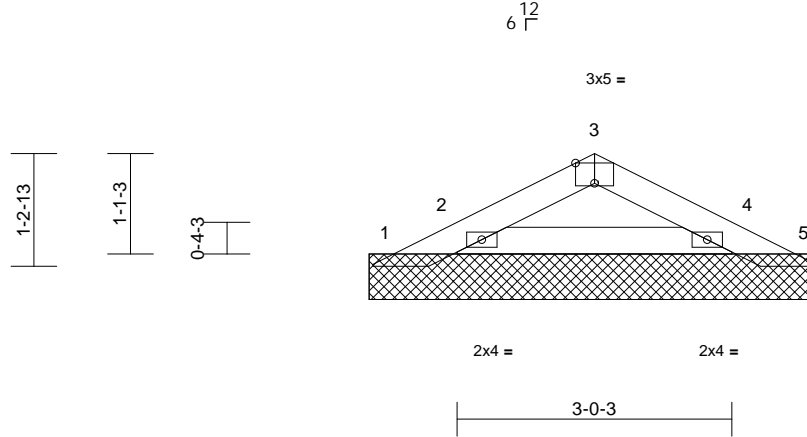

Scale = 1:25.3

Plate Offsets (X, Y): [3:0-2-8,Edge]

Loading	(psf)	Spacing	2-0-0	CSI	DEFL	in	(loc)	l/defl	L/d	PLATES	GRIP	
TCLL (roof)	20.0	Plate Grip DOL	1.15	TC	0.06	Vert(LL)	n/a	-	n/a	999	MT20	244/190
Snow (Pf)	20.0	Lumber DOL	1.15	BC	0.04	Vert(TL)	n/a	-	n/a	999		
TCDL	10.0	Rep Stress Incr	YES	WB	0.00	Horiz(TL)	0.00	9	n/a	n/a		
BCLL	0.0*	Code	IRC2018/TPI2014	Matrix-MP								
BCDL	10.0											
										Weight: 13 lb	FT = 20%	

LUMBER

TOP CHORD 2x4 SP No.2
BOT CHORD 2x4 SP No.2

BRACING

TOP CHORD Structural wood sheathing directly applied or 4-11-5 oc purlins.
BOT CHORD Rigid ceiling directly applied or 10-0-0 oc bracing.

REACTIONS

(size) 1=4-11-5, 2=4-11-5, 4=4-11-5, 5=4-11-5, 6=4-11-5, 9=4-11-5
Max Horiz 1=-17 (LC 15)
Max Uplift 1=-21 (LC 7), 2=-18 (LC 14), 4=-17 (LC 15), 5=-19 (LC 7), 6=-18 (LC 14), 9=-17 (LC 15)
Max Grav 1=5 (LC 14), 2=228 (LC 21), 4=216 (LC 22), 5=-1 (LC 14), 6=228 (LC 21), 9=216 (LC 22)

FORCES

(lb) - Maximum Compression/Maximum Tension

TOP CHORD 1-2=-17/39, 2-3=-102/60, 3-4=-102/60, 4-5=0/34
BOT CHORD 2-4=-1/76

NOTES

- Unbalanced roof live loads have been considered for this design.
- Wind: ASCE 7-16; Vult=130mph (3-second gust) Vasd=103mph; TCDL=6.0psf; BCDL=6.0psf; h=25ft; Cat. II; Exp B; Enclosed; MWFRS (envelope) exterior zone and C-C Exterior(2E) zone; cantilever left and right exposed; end vertical left and right exposed; C-C for members and forces & MWFRS for reactions shown; Lumber DOL=1.60 plate grip DOL=1.60
- Truss designed for wind loads in the plane of the truss only. For studs exposed to wind (normal to the face), see Standard Industry Gable End Details as applicable, or consult qualified building designer as per ANSI/TPI 1.

- TCLL: ASCE 7-16; Pr=20.0 psf (roof LL: Lum DOL=1.15 Plate DOL=1.15); Pf=20.0 psf (Lum DOL=1.15 Plate DOL=1.15); Is=1.0; Rough Cat B; Fully Exp.; Ce=0.9; Cs=1.00; Ct=1.10
- Unbalanced snow loads have been considered for this design.
- Gable requires continuous bottom chord bearing.
- Gable studs spaced at 4-0-0 oc.
- This truss has been designed for a 10.0 psf bottom chord live load nonconcurrent with any other live loads.
- * This truss has been designed for a live load of 20.0psf on the bottom chord in all areas where a rectangle 3-06-00 tall by 2-00-00 wide will fit between the bottom chord and any other members.
- Provide mechanical connection (by others) of truss to bearing plate capable of withstanding 21 lb uplift at joint 1 and 19 lb uplift at joint 5.
- N/A
- This truss is designed in accordance with the 2018 International Residential Code sections R502.11.1 and R802.10.2 and referenced standard ANSI/TPI 1.
- See Standard Industry Piggyback Truss Connection Detail for Connection to base truss as applicable, or consult qualified building designer.

LOAD CASE(S) Standard



April 1, 2024

WARNING - Verify design parameters and READ NOTES ON THIS AND INCLUDED MITEK REFERENCE PAGE MII-7473 rev. 1/2/2023 BEFORE USE.

Design valid for use only with MiTek® connectors. This design is based only upon parameters shown, and is for an individual building component, not a truss system. Before use, the building designer must verify the applicability of design parameters and properly incorporate this design into the overall building design. Bracing indicated is to prevent buckling of individual truss web and/or chord members only. Additional temporary and permanent bracing is always required for stability and to prevent collapse with possible personal injury and property damage. For general guidance regarding the fabrication, storage, delivery, erection and bracing of trusses and truss systems, see **ANSI/TPI1 Quality Criteria and DSB-22** available from Truss Plate Institute (www.tpinst.org) and **BCSI Building Component Safety Information** available from the Structural Building Component Association (www.sbcacomponents.com)



818 Soundside Road
Edenton, NC 27932

Job 24030153-01	Truss FGE	Truss Type Common Supported Gable	Qty 1	Ply 1	142 Serenity-Roof-B329 B LH CP Job Reference (optional)	164576291
--------------------	--------------	--------------------------------------	----------	----------	--	-----------

Carter Components (Sanford, NC), Sanford, NC - 27332,

Run: 9.03 S 8.73 Mar 21 2024 Print: 8.730 S Mar 21 2024 MiTek Industries, Inc. Fri Mar 29 10:41:42

Page: 1

ID:qVUv8gQtzqhC01RU7_rhkzMD2N-RfC?PsB70Hq3NSgPqnL8w3uITXbGKWrCDoi7J4zJC?f

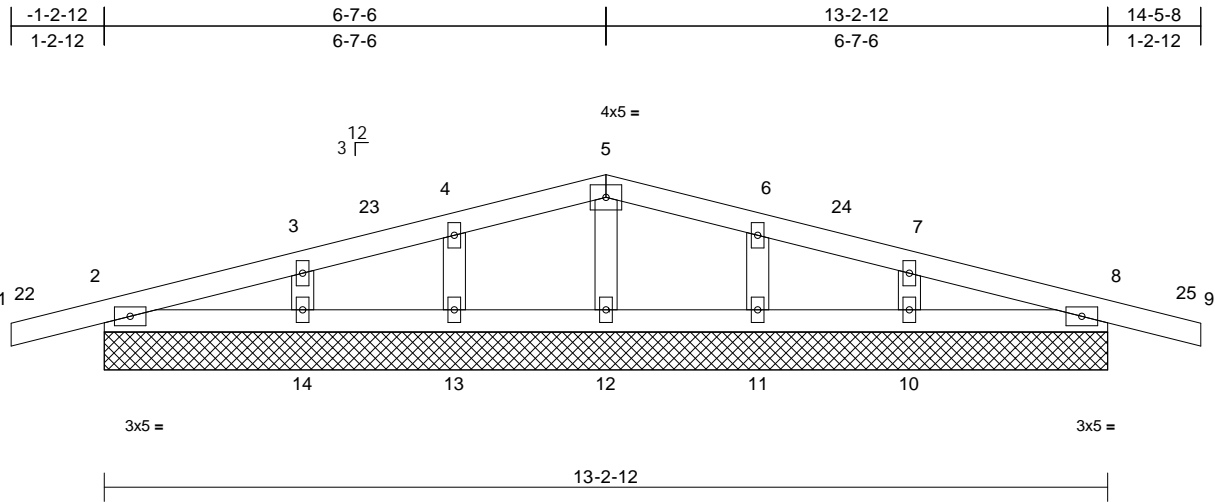

Scale = 1:30.4

Loading	(psf)	Spacing	2-0-0	CSI	DEFL	in	(loc)	l/defl	L/d	PLATES	GRIP
TCLL (roof)	20.0	Plate Grip DOL	1.15	TC	0.12	Vert(LL)	n/a	-	999	MT20	244/190
Snow (Pf)	20.0	Lumber DOL	1.15	BC	0.04	Vert(CT)	n/a	-	999		
TCDL	10.0	Rep Stress Incr	YES	WB	0.04	Horz(CT)	0.00	19	n/a		
BCLL	0.0*	Code	IRC2018/TPI2014	Matrix-MSH							
BCDL	10.0										
										Weight: 51 lb	FT = 20%

LUMBER

TOP CHORD 2x4 SP No.2
BOT CHORD 2x4 SP No.2
OTHERS 2x4 SP No.3

BRACING

TOP CHORD Structural wood sheathing directly applied or 6-0-0 oc purlins.
BOT CHORD Rigid ceiling directly applied or 10-0-0 oc bracing.

REACTIONS

(size) 2=13-2-12, 8=13-2-12, 10=13-2-12, 11=13-2-12, 12=13-2-12, 13=13-2-12, 14=13-2-12, 15=13-2-12, 19=13-2-12
Max Horiz 2=-31 (LC 19), 15=-31 (LC 19)
Max Uplift 2=-67 (LC 10), 8=-71 (LC 11), 10=-32 (LC 15), 11=-36 (LC 11), 13=-36 (LC 10), 14=-33 (LC 14), 15=-67 (LC 10), 19=-71 (LC 11)
Max Grav 2=241 (LC 21), 8=241 (LC 22), 10=247 (LC 22), 11=211 (LC 22), 12=146 (LC 1), 13=211 (LC 21), 14=247 (LC 21), 15=241 (LC 21), 19=241 (LC 22)

FORCES

(lb) - Maximum Compression/Maximum Tension

TOP CHORD 1-2=0/24, 2-3=-59/49, 3-4=-35/45, 4-5=-40/83, 5-6=-40/83, 6-7=-35/45, 7-8=-59/49, 8-9=0/24
BOT CHORD 2-14=-48/70, 13-14=0/38, 12-13=0/38, 11-12=0/38, 10-11=0/38, 8-10=-48/70
WEBS 5-12=-104/68, 4-13=-178/132, 3-14=-186/105, 6-11=-178/132, 7-10=-186/105

NOTES

1) Unbalanced roof live loads have been considered for this design.

- Wind: ASCE 7-16; Vult=130mph (3-second gust) Vasd=103mph; TCDL=6.0psf; BCDL=6.0psf; h=25ft; Cat. II; Exp B; Enclosed; MWFRS (envelope) exterior zone and C-C Corner(3E) -0-10-8 to 2-1-8, Exterior(2N) 2-1-8 to 3-11-10, Corner(3R) 3-11-10 to 9-11-10, Exterior(2N) 9-11-10 to 11-9-12, Corner(3E) 11-9-12 to 14-9-12 zone; cantilever left and right exposed ; end vertical left and right exposed;C-C for members and forces & MWFRS for reactions shown; Lumber DOL=1.60 plate grip DOL=1.60
- Truss designed for wind loads in the plane of the truss only. For studs exposed to wind (normal to the face), see Standard Industry Gable End Details as applicable, or consult qualified building designer as per ANSI/TPI 1.
- TCLL: ASCE 7-16; Pr=20.0 psf (roof LL: Lum DOL=1.15 Plate DOL=1.15); Pf=20.0 psf (Lum DOL=1.15 Plate DOL=1.15); Is=1.0; Rough Cat B; Fully Exp.; Ce=0.9; Cs=1.00; Ct=1.10
- Unbalanced snow loads have been considered for this design.
- This truss has been designed for greater of min roof live load of 12.0 psf or 1.00 times flat roof load of 20.0 psf on overhangs non-concurrent with other live loads.
- All plates are 2x4 MT20 unless otherwise indicated.
- Gable requires continuous bottom chord bearing.
- Gable studs spaced at 2-0-0 oc.
- This truss has been designed for a 10.0 psf bottom chord live load nonconcurrent with any other live loads.
- * This truss has been designed for a live load of 20.0psf on the bottom chord in all areas where a rectangle 3-06-00 tall by 2-00-00 wide will fit between the bottom chord and any other members.
- N/A

14) This truss is designed in accordance with the 2018 International Residential Code sections R502.11.1 and R802.10.2 and referenced standard ANSI/TPI 1.

LOAD CASE(S) Standard



April 1, 2024

WARNING - Verify design parameters and READ NOTES ON THIS AND INCLUDED MITEK REFERENCE PAGE MII-7473 rev. 1/2/2023 BEFORE USE.

Design valid for use only with MiTek® connectors. This design is based only upon parameters shown, and is for an individual building component, not a truss system. Before use, the building designer must verify the applicability of design parameters and properly incorporate this design into the overall building design. Bracing indicated is to prevent buckling of individual truss web and/or chord members only. Additional temporary and permanent bracing is always required for stability and to prevent collapse with possible personal injury and property damage. For general guidance regarding the fabrication, storage, delivery, erection and bracing of trusses and truss systems, see **ANSI/TPI1 Quality Criteria and DSB-22** available from Truss Plate Institute (www.tpinst.org) and **BCSI Building Component Safety Information** available from the Structural Building Component Association (www.sbcacomponents.com)

ENGINEERING BY
TRENCO
A MiTek Affiliate

818 Soundside Road
Edenton, NC 27932

Job 24030153-01	Truss F	Truss Type Common	Qty 2	Ply 1	142 Serenity-Roof-B329 B LH CP Job Reference (optional)	164576292
--------------------	------------	----------------------	----------	----------	--	-----------

Carter Components (Sanford, NC), Sanford, NC - 27332,

Run: 9.03 S 8.73 Mar 21 2024 Print: 8.730 S Mar 21 2024 MiTek Industries, Inc. Fri Mar 29 10:41:42
ID: jpnH6gUj0VTRIsxki5glElzMD1n-RfC?PsB70Hq3NSgPqnL8w3uITXbGKWRcDoi7J4zJC?f

Page: 1

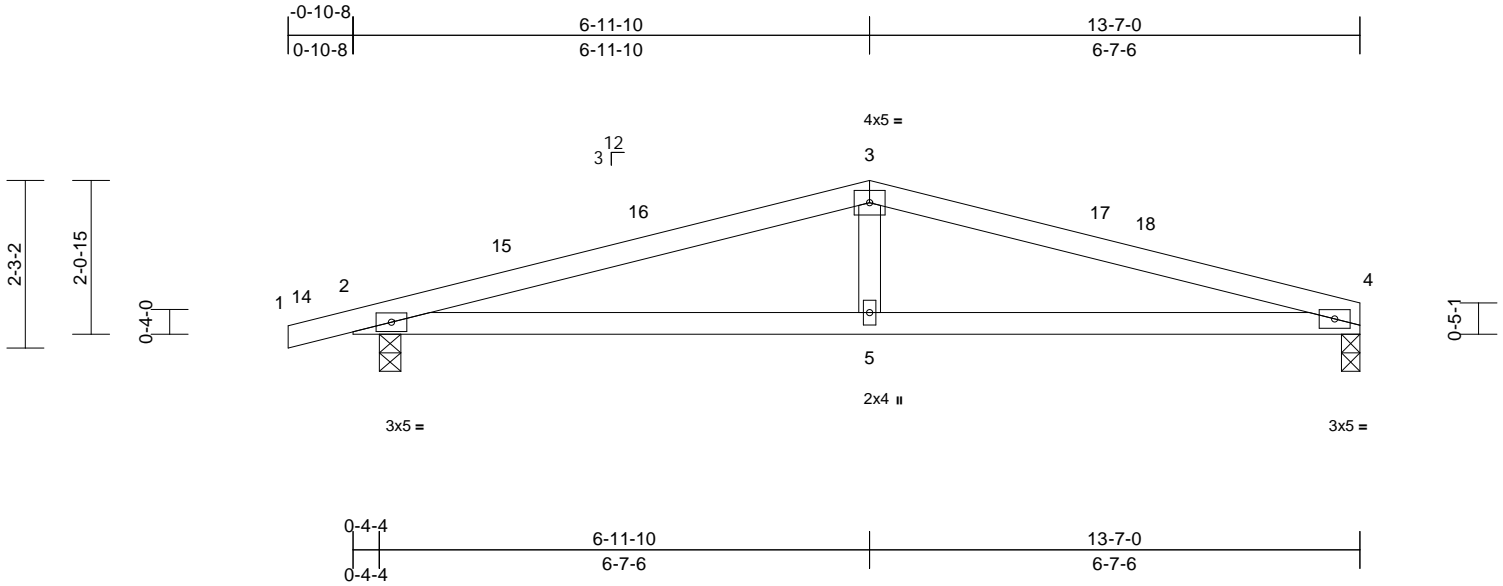

Scale = 1:31.1

Loading	(psf)	Spacing	2-0-0	CSI	DEFL	in	(loc)	l/defl	L/d	PLATES	GRIP
TCLL (roof)	20.0	Plate Grip DOL	1.15	TC	Vert(LL)	-0.11	5-8	>999	240	MT20	244/190
Snow (Pf)	20.0	Lumber DOL	1.15	BC	Vert(CT)	-0.17	5-8	>954	180		
TCDL	10.0	Rep Stress Incr	YES	WB	Horz(CT)	0.02	4	n/a	n/a		
BCLL	0.0*	Code	IRC2018/TPI2014	Matrix-MSH							
BCDL	10.0									Weight: 45 lb	FT = 20%

LUMBER

TOP CHORD 2x4 SP No.2
BOT CHORD 2x4 SP No.2
WEBS 2x4 SP No.3

BRACING

TOP CHORD Structural wood sheathing directly applied or 2-6-7 oc purlins.
BOT CHORD Rigid ceiling directly applied or 6-5-2 oc bracing.

REACTIONS

(size) 2=0-3-8, 4=0-3-0
Max Horiz 2=36 (LC 14)
Max Uplift 2=-221 (LC 10), 4=-176 (LC 11)
Max Grav 2=716 (LC 21), 4=605 (LC 22)

FORCES

(lb) - Maximum Compression/Maximum Tension
TOP CHORD 1-2=0/16, 2-3=-1182/848, 3-4=-1188/846
BOT CHORD 2-5=-760/1105, 4-5=-760/1105
WEBS 3-5=-130/285

NOTES

- Unbalanced roof live loads have been considered for this design.
- Wind: ASCE 7-16; Vult=130mph (3-second gust) Vasd=103mph; TCDL=6.0psf; BCDL=6.0psf; h=25ft; Cat. II; Exp B; Enclosed; MWFRS (envelope) exterior zone and C-C Exterior(2E) -0-10-8 to 2-1-8, Interior (1) 2-1-8 to 3-11-10, Exterior(2R) 3-11-10 to 9-11-10, Interior (1) 9-11-10 to 10-7-0, Exterior(2E) 10-7-0 to 13-7-0 zone; cantilever left and right exposed; end vertical left and right exposed; porch left and right exposed; C-C for members and forces & MWFRS for reactions shown; Lumber DOL=1.60 plate grip DOL=1.60
- TCLL: ASCE 7-16; Pr=20.0 psf (roof LL: Lum DOL=1.15 Plate DOL=1.15); Pf=20.0 psf (Lum DOL=1.15 Plate DOL=1.15); Is=1.0; Rough Cat B; Fully Exp.; Ce=0.9; Cs=1.00; Ct=1.10
- Unbalanced snow loads have been considered for this design.

- This truss has been designed for greater of min roof live load of 12.0 psf or 1.00 times flat roof load of 20.0 psf on overhangs non-concurrent with other live loads.
 - This truss has been designed for a 10.0 psf bottom chord live load nonconcurrent with any other live loads.
 - * This truss has been designed for a live load of 20.0psf on the bottom chord in all areas where a rectangle 3-06-00 tall by 2-00-00 wide will fit between the bottom chord and any other members.
 - One H2.5A Simpson Strong-Tie connectors recommended to connect truss to bearing walls due to UPLIFT at jt(s) 4 and 2. This connection is for uplift only and does not consider lateral forces.
 - This truss is designed in accordance with the 2018 International Residential Code sections R502.11.1 and R802.10.2 and referenced standard ANSI/TPI 1.
- LOAD CASE(S)** Standard



April 1, 2024

WARNING - Verify design parameters and READ NOTES ON THIS AND INCLUDED MITEK REFERENCE PAGE MII-7473 rev. 1/2/2023 BEFORE USE.

Design valid for use only with MiTek® connectors. This design is based only upon parameters shown, and is for an individual building component, not a truss system. Before use, the building designer must verify the applicability of design parameters and properly incorporate this design into the overall building design. Bracing indicated is to prevent buckling of individual truss web and/or chord members only. Additional temporary and permanent bracing is always required for stability and to prevent collapse with possible personal injury and property damage. For general guidance regarding the fabrication, storage, delivery, erection and bracing of trusses and truss systems, see **ANSI/TPI1 Quality Criteria and DSB-22** available from Truss Plate Institute (www.tpinst.org) and **BCSI Building Component Safety Information** available from the Structural Building Component Association (www.sbcacomponents.com)



818 Soundside Road
Edenton, NC 27932

Job 24030153-01	Truss ISE	Truss Type Monopitch Structural Gable	Qty 1	Ply 1	142 Serenity-Roof-B329 B LH CP Job Reference (optional)	164576293
--------------------	--------------	--	----------	----------	--	-----------

Carter Components (Sanford, NC), Sanford, NC - 27332,

Run: 9.03 S 8.73 Mar 21 2024 Print: 8.730 S Mar 21 2024 MiTek Industries, Inc. Fri Mar 29 10:41:42

Page: 1

ID:INPZ5e0g9muGd0LDY9HBQAzMCx9-RfC?PsB70Hq3NSgPqnL8w3uITXbGKwRCDoi7J4zJC?f

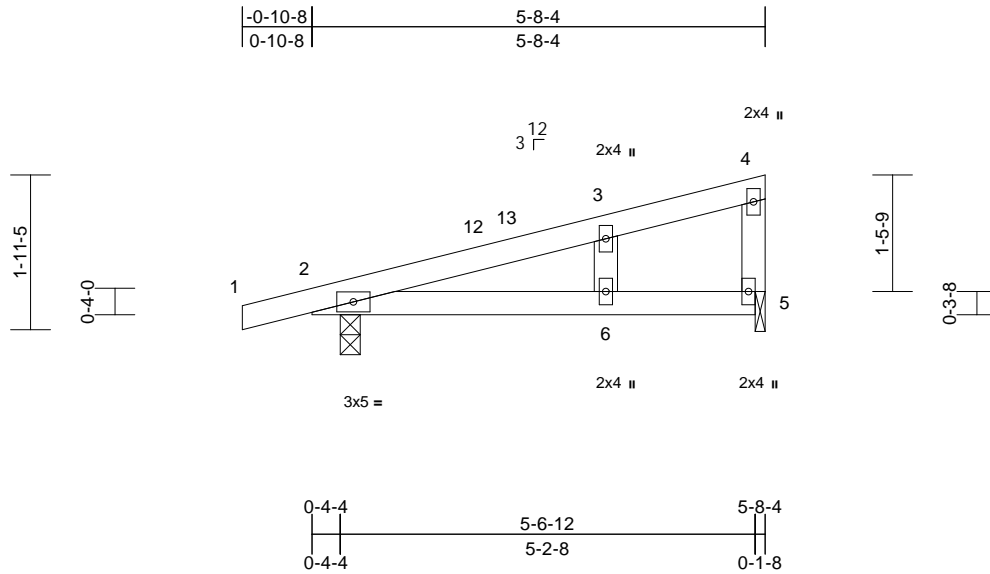

Loading	(psf)	Spacing	2-0-0	CSI	DEFL	in	(loc)	l/defl	L/d	PLATES	GRIP	
TCLL (roof)	20.0	Plate Grip DOL	1.15	TC	0.38	Vert(LL)	0.08	6-11	>859	240	MT20	244/190
Snow (Pf)	20.0	Lumber DOL	1.15	BC	0.44	Vert(CT)	-0.10	6-11	>653	180		
TCDL	10.0	Rep Stress Incr	YES	WB	0.02	Horz(CT)	0.00	2	n/a	n/a		
BCLL	0.0*	Code	IRC2018/TPI2014	Matrix-MP								
BCDL	10.0											
											Weight: 21 lb	FT = 20%

LUMBER
 TOP CHORD 2x4 SP No.2
 BOT CHORD 2x4 SP No.2
 WEBS 2x4 SP No.3
 OTHERS 2x4 SP No.3

BRACING
 TOP CHORD Structural wood sheathing directly applied or 5-8-4 oc purlins, except end verticals.
 BOT CHORD Rigid ceiling directly applied or 10-0-0 oc bracing.

REACTIONS (size) 2=0-3-0, 5=0-1-8
 Max Horiz 2=58 (LC 13)
 Max Uplift 2=-123 (LC 10), 5=-76 (LC 10)
 Max Grav 2=397 (LC 21), 5=260 (LC 21)

FORCES (lb) - Maximum Compression/Maximum Tension
 TOP CHORD 1-2=0/18, 2-3=-101/118, 3-4=-25/40, 4-5=-149/121
 BOT CHORD 2-6=-118/127, 5-6=-18/27
 WEBS 3-6=-84/70

- NOTES**
- 1) Wind: ASCE 7-16; Vult=130mph (3-second gust) Vasd=103mph; TCDL=6.0psf; BCDL=6.0psf; h=25ft; Cat. II; Exp B; Enclosed; MWFRS (envelope) exterior zone and C-C Exterior(2E) -0-10-8 to 2-1-8, Interior (1) 2-1-8 to 2-6-8, Exterior(2E) 2-6-8 to 5-6-8 zone; cantilever left and right exposed; end vertical left and right exposed; porch left and right exposed; C-C for members and forces & MWFRS for reactions shown; Lumber DOL=1.60 plate grip DOL=1.60
 - 2) Truss designed for wind loads in the plane of the truss only. For studs exposed to wind (normal to the face), see Standard Industry Gable End Details as applicable, or consult qualified building designer as per ANSI/TPI 1.
 - 3) TCLL: ASCE 7-16; Pr=20.0 psf (roof LL: Lum DOL=1.15 Plate DOL=1.15); Pf=20.0 psf (Lum DOL=1.15 Plate DOL=1.15); Is=1.0; Rough Cat B; Fully Exp.; Ce=0.9; Cs=1.00; Ct=1.10

- 4) Unbalanced snow loads have been considered for this design.
- 5) This truss has been designed for greater of min roof live load of 12.0 psf or 1.00 times flat roof load of 20.0 psf on overhangs non-concurrent with other live loads.
- 6) Gable studs spaced at 2-0-0 oc.
- 7) This truss has been designed for a 10.0 psf bottom chord live load nonconcurrent with any other live loads.
- 8) * This truss has been designed for a live load of 20.0psf on the bottom chord in all areas where a rectangle 3-06-00 tall by 2-00-00 wide will fit between the bottom chord and any other members.
- 9) Bearings are assumed to be: Joint 5 SP No.3 .
- 10) Bearing at joint(s) 5 considers parallel to grain value using ANSI/TPI 1 angle to grain formula. Building designer should verify capacity of bearing surface.
- 11) Provide mechanical connection (by others) of truss to bearing plate at joint(s) 5.
- 12) One H2.5A Simpson Strong-Tie connectors recommended to connect truss to bearing walls due to UPLIFT at jt(s) 5 and 2. This connection is for uplift only and does not consider lateral forces.
- 13) This truss is designed in accordance with the 2018 International Residential Code sections R502.11.1 and R802.10.2 and referenced standard ANSI/TPI 1.

LOAD CASE(S) Standard



April 1, 2024

WARNING - Verify design parameters and READ NOTES ON THIS AND INCLUDED MITEK REFERENCE PAGE MII-7473 rev. 1/2/2023 BEFORE USE.

Design valid for use only with MiTek® connectors. This design is based only upon parameters shown, and is for an individual building component, not a truss system. Before use, the building designer must verify the applicability of design parameters and properly incorporate this design into the overall building design. Bracing indicated is to prevent buckling of individual truss web and/or chord members only. Additional temporary and permanent bracing is always required for stability and to prevent collapse with possible personal injury and property damage. For general guidance regarding the fabrication, storage, delivery, erection and bracing of trusses and truss systems, see **ANSI/TPI Quality Criteria and DSB-22** available from Truss Plate Institute (www.tpinst.org) and **BCSI Building Component Safety Information** available from the Structural Building Component Association (www.sbcacomponents.com)

ENGINEERING BY
TRENCO
 A MiTek Affiliate

818 Soundside Road
 Edenton, NC 27932

Job 24030153-01	Truss I	Truss Type Monopitch	Qty 5	Ply 1	142 Serenity-Roof-B329 B LH CP Job Reference (optional)	164576294
--------------------	------------	-------------------------	----------	----------	--	-----------

Carter Components (Sanford, NC), Sanford, NC - 27332,

Run: 9.03 S 8.73 Mar 21 2024 Print: 8.730 S Mar 21 2024 MiTek Industries, Inc. Fri Mar 29 10:41:42
ID:nEFoQGTSTYeU8OA94u2Fj5zMD10-RfC?PsB70Hq3NSgPqnL8w3uTXbGKWrCDoi7J4zJC?f

Page: 1

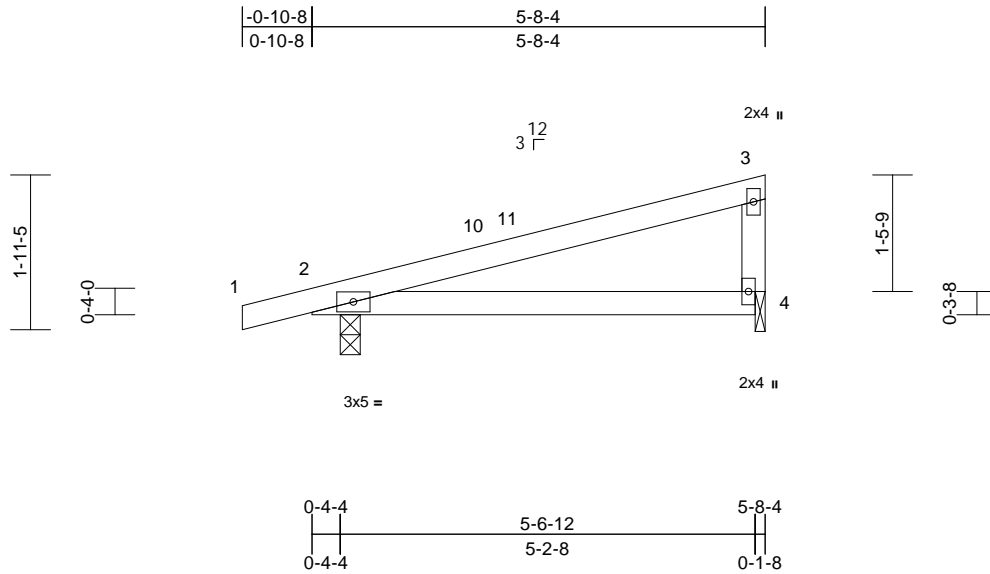

Scale = 1:28.9

Loading	(psf)	Spacing	2-0-0	CSI	DEFL	in	(loc)	l/defl	L/d	PLATES	GRIP	
TCLL (roof)	20.0	Plate Grip DOL	1.15	TC	0.51	Vert(LL)	0.07	4-9	>967	240	MT20	244/190
Snow (Pf)	20.0	Lumber DOL	1.15	BC	0.37	Vert(CT)	-0.09	4-9	>762	180		
TCDL	10.0	Rep Stress Incr	YES	WB	0.00	Horz(CT)	0.00	2	n/a	n/a		
BCLL	0.0*	Code	IRC2018/TPI2014	Matrix-MP								
BCDL	10.0										Weight: 20 lb	FT = 20%

LUMBER

TOP CHORD 2x4 SP No.2
BOT CHORD 2x4 SP No.2
WEBS 2x4 SP No.3

BRACING

TOP CHORD Structural wood sheathing directly applied or 5-8-4 oc purlins, except end verticals.
BOT CHORD Rigid ceiling directly applied or 10-0-0 oc bracing.

REACTIONS

(size) 2=0-3-0, 4=0-1-8
Max Horiz 2=58 (LC 13)
Max Uplift 2=-123 (LC 10), 4=-76 (LC 10)
Max Grav 2=397 (LC 21), 4=260 (LC 21)

FORCES

(lb) - Maximum Compression/Maximum Tension
TOP CHORD 1-2=0/18, 2-3=-101/118, 3-4=-185/151
BOT CHORD 2-4=-118/127

NOTES

- 1) Wind: ASCE 7-16; Vult=130mph (3-second gust) Vasd=103mph; TCDL=6.0psf; BCDL=6.0psf; h=25ft; Cat. II; Exp B; Enclosed; MWFRS (envelope) exterior zone and C-C Exterior(2E) -0-10-8 to 2-1-8, Interior (1) 2-1-8 to 2-6-8, Exterior(2E) 2-6-8 to 5-6-8 zone; cantilever left and right exposed; end vertical left and right exposed; porch left and right exposed; C-C for members and forces & MWFRS for reactions shown; Lumber DOL=1.60 plate grip DOL=1.60
- 2) TCLL: ASCE 7-16; Pr=20.0 psf (roof LL: Lum DOL=1.15 Plate DOL=1.15); Pf=20.0 psf (Lum DOL=1.15 Plate DOL=1.15); Is=1.0; Rough Cat B; Fully Exp.; Ce=0.9; Cs=1.00; Ct=1.10
- 3) Unbalanced snow loads have been considered for this design.
- 4) This truss has been designed for greater of min roof live load of 12.0 psf or 1.00 times flat roof load of 20.0 psf on overhangs non-concurrent with other live loads.
- 5) This truss has been designed for a 10.0 psf bottom chord live load nonconcurrent with any other live loads.

- 6) * This truss has been designed for a live load of 20.0psf on the bottom chord in all areas where a rectangle 3-06-00 tall by 2-00-00 wide will fit between the bottom chord and any other members.
- 7) Bearings are assumed to be: Joint 4 SP No.3 .
- 8) Bearing at joint(s) 4 considers parallel to grain value using ANSI/TPI 1 angle to grain formula. Building designer should verify capacity of bearing surface.
- 9) Provide mechanical connection (by others) of truss to bearing plate at joint(s) 4.
- 10) One H2.5A Simpson Strong-Tie connectors recommended to connect truss to bearing walls due to UPLIFT at jt(s) 4 and 2. This connection is for uplift only and does not consider lateral forces.
- 11) This truss is designed in accordance with the 2018 International Residential Code sections R502.11.1 and R802.10.2 and referenced standard ANSI/TPI 1.

LOAD CASE(S) Standard



April 1, 2024

WARNING - Verify design parameters and READ NOTES ON THIS AND INCLUDED MITEK REFERENCE PAGE MII-7473 rev. 1/2/2023 BEFORE USE.

Design valid for use only with MiTek® connectors. This design is based only upon parameters shown, and is for an individual building component, not a truss system. Before use, the building designer must verify the applicability of design parameters and properly incorporate this design into the overall building design. Bracing indicated is to prevent buckling of individual truss web and/or chord members only. Additional temporary and permanent bracing is always required for stability and to prevent collapse with possible personal injury and property damage. For general guidance regarding the fabrication, storage, delivery, erection and bracing of trusses and truss systems, see **ANSI/TPI1 Quality Criteria and DSB-22** available from Truss Plate Institute (www.tpinst.org) and **BCSI Building Component Safety Information** available from the Structural Building Component Association (www.sbcacomponents.com)



818 Soundside Road
Edenton, NC 27932

Job 24030153-01	Truss C	Truss Type Monopitch	Qty 1	Ply 1	142 Serenity-Roof-B329 B LH CP Job Reference (optional)	164576295
--------------------	------------	-------------------------	----------	----------	--	-----------

Carter Components (Sanford, NC), Sanford, NC - 27332,

Run: 9.03 S 8.73 Mar 21 2024 Print: 8.730 S Mar 21 2024 MiTek Industries, Inc. Fri Mar 29 10:41:40

Page: 1

ID: BtC6kK9j1Q8nN87NoP6J5z2Qj3-RfC?PsB70Hq3NSgPqnL8w3uITXbGKWRcDoi7J4zJC?f

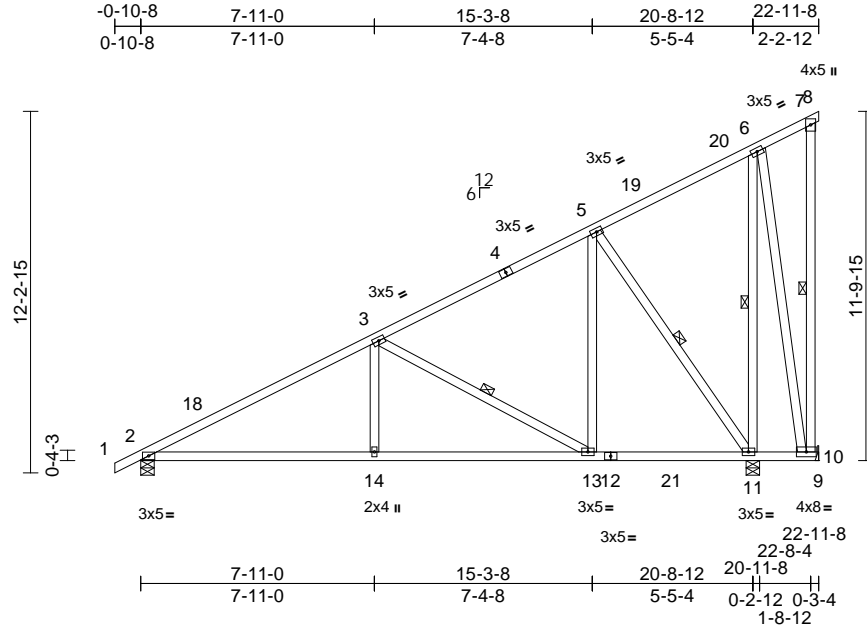

Scale = 1:78

Loading	(psf)	Spacing	1-11-4	CSI	DEFL	in	(loc)	l/defl	L/d	PLATES	GRIP
TCLL (roof)	20.0	Plate Grip DOL	1.15	TC	0.80	Vert(LL)	-0.14	14-17	>999	240	244/190
Snow (Pf)	20.0	Lumber DOL	1.15	BC	0.80	Vert(CT)	-0.27	14-17	>914	180	
TCDL	10.0	Rep Stress Incr	YES	WB	0.43	Horz(CT)	0.03	11	n/a	n/a	
BCLL	0.0*	Code	IRC2018/TPI2014	Matrix-MSH							
BCDL	10.0										
										Weight: 163 lb	FT = 20%

LUMBER	
TOP CHORD	2x4 SP No.2
BOT CHORD	2x4 SP No.2
WEBS	2x4 SP No.3 *Except* 7-10,6-11,6-10:2x4 SP No.2
BRACING	
TOP CHORD	Structural wood sheathing directly applied or 4-0-10 oc purlins, except end verticals.
BOT CHORD	Rigid ceiling directly applied or 10-0-0 oc bracing, Except:
	6-0-0 oc bracing: 10-11.
WEBS	1 Row at midpt 7-10, 3-13, 5-11, 6-11
REACTIONS	
(size)	2=0-5-8, 10= Mechanical, 11=0-5-8
Max Horiz	2=422 (LC 13)
Max Uplift	2=-80 (LC 14), 10=-257 (LC 31), 11=-258 (LC 14)
Max Grav	2=892 (LC 5), 10=50 (LC 10), 11=1346 (LC 5)
FORCES	
(lb) - Maximum Compression/Maximum Tension	
TOP CHORD	1-2=0/23, 2-3=-1349/147, 3-5=-684/129, 5-6=-188/219, 6-7=-132/149, 7-8=-12/0, 7-10=-29/41
BOT CHORD	2-14=-200/1420, 13-14=-200/1420, 11-13=-119/625, 10-11=-165/194, 9-10=0/0
WEBS	3-14=0/329, 3-13=-904/203, 5-13=-9/669, 5-11=-959/208, 6-11=-486/58, 6-10=-26/203

- TCLL: ASCE 7-16; Pr=20.0 psf (roof LL: Lum DOL=1.15 Plate DOL=1.15); Pf=20.0 psf (Lum DOL=1.15 Plate DOL=1.15); Is=1.0; Rough Cat B; Fully Exp.; Ce=0.9; Cs=1.00; Ct=1.10
- Unbalanced snow loads have been considered for this design.
- This truss has been designed for greater of min roof live load of 12.0 psf or 1.00 times flat roof load of 20.0 psf on overhangs non-concurrent with other live loads.
- All plates are 3x5 MT20 unless otherwise indicated.
- This truss has been designed for a 10.0 psf bottom chord live load nonconcurrent with any other live loads.
- * This truss has been designed for a live load of 20.0psf on the bottom chord in all areas where a rectangle 3-06-00 tall by 2-00-00 wide will fit between the bottom chord and any other members, with BCDL = 10.0psf.
- Refer to girder(s) for truss to truss connections.
- Provide mechanical connection (by others) of truss to bearing plate capable of withstanding 257 lb uplift at joint 10.
- One H2.5A Simpson Strong-Tie connectors recommended to connect truss to bearing walls due to UPLIFT at jt(s) 2 and 11. This connection is for uplift only and does not consider lateral forces.
- This truss is designed in accordance with the 2018 International Residential Code sections R502.11.1 and R802.10.2 and referenced standard ANSI/TPI 1.

LOAD CASE(S) Standard

NOTES

- Wind: ASCE 7-16; Vult=130mph (3-second gust) Vasd=103mph; TCDL=6.0psf; BCDL=6.0psf; h=25ft; Cat. II; Exp B; Enclosed; MWFRS (envelope) exterior zone and C-C Exterior(2E) -0-10-8 to 2-1-8, Interior (1) 2-1-8 to 19-11-8, Exterior(2E) 19-11-8 to 22-11-8 zone; cantilever left and right exposed ; end vertical left and right exposed;C-C for members and forces & MWFRS for reactions shown; Lumber DOL=1.60 plate grip DOL=1.60

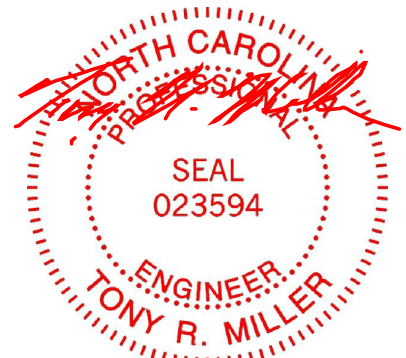

April 1, 2024

WARNING - Verify design parameters and READ NOTES ON THIS AND INCLUDED MITEK REFERENCE PAGE MII-7473 rev. 1/2/2023 BEFORE USE.

Design valid for use only with MiTek® connectors. This design is based only upon parameters shown, and is for an individual building component, not a truss system. Before use, the building designer must verify the applicability of design parameters and properly incorporate this design into the overall building design. Bracing indicated is to prevent buckling of individual truss web and/or chord members only. Additional temporary and permanent bracing is always required for stability and to prevent collapse with possible personal injury and property damage. For general guidance regarding the fabrication, storage, delivery, erection and bracing of trusses and truss systems, see **ANSI/TPI1 Quality Criteria and DSB-22** available from Truss Plate Institute (www.tpinst.org) and **BCSI Building Component Safety Information** available from the Structural Building Component Association (www.sbcacomponents.com)



818 Soundside Road
Edenton, NC 27932

Job 24030153-01	Truss KGR	Truss Type Half Hip Girder	Qty 1	Ply 2	142 Serenity-Roof-B329 B LH CP Job Reference (optional)	164576296
--------------------	--------------	-------------------------------	----------	----------	--	-----------

Carter Components (Sanford, NC), Sanford, NC - 27332,

Run: 9.03 S 8.73 Mar 21 2024 Print: 8.730 S Mar 21 2024 MiTek Industries, Inc. Fri Mar 29 10:41:43

Page: 1

ID:T3jl1iM2Fv9ehg9GdEVZ1z17hh-RfC?PsB70Hq3NSgPqnL8w3ulTXbGkWrCDoi7J4zJC?f

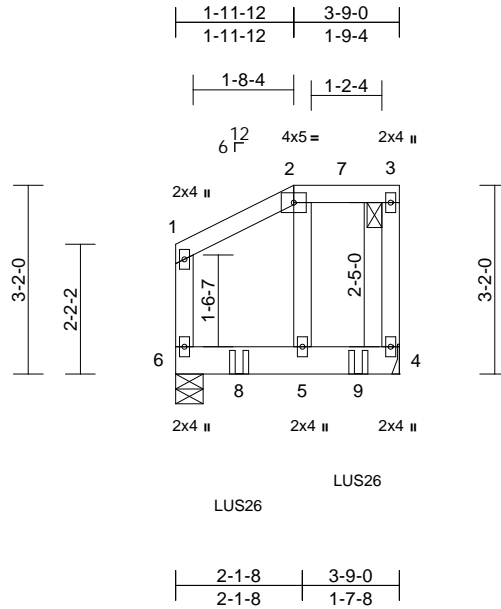

Loading	(psf)	Spacing	2-0-0	CSI	DEFL	in	(loc)	l/defl	L/d	PLATES	GRIP
TCLL (roof)	20.0	Plate Grip DOL	1.15	TC	0.30	Vert(LL)	-0.01	5-6	>999	240	244/190
Snow (Pf)	20.0	Lumber DOL	1.15	BC	0.30	Vert(CT)	-0.02	5-6	>999	180	
TCDL	10.0	Rep Stress Incr	NO	WB	0.03	Horz(CT)	0.00	4	n/a	n/a	
BCLL	0.0*	Code	IRC2018/TPI2014	Matrix-MR							
BCDL	10.0										
										Weight: 49 lb	FT = 20%

LUMBER
TOP CHORD 2x4 SP No.2
BOT CHORD 2x6 SP No.2
WEBS 2x4 SP No.3

BRACING
TOP CHORD Structural wood sheathing directly applied or 6-0-0 oc purlins, except end verticals, and 2-0-0 oc purlins (6-0-0 max.): 2-3
BOT CHORD Rigid ceiling directly applied or 10-0-0 oc bracing.

REACTIONS (size) 4= Mechanical, 6=0-5-8
Max Horiz 6=99 (LC 9)
Max Uplift 4=141 (LC 9), 6=94 (LC 12)
Max Grav 4=1076 (LC 32), 6=901 (LC 33)

FORCES (lb) - Maximum Compression/Maximum Tension
TOP CHORD 1-2=-154/32, 2-3=-84/31, 3-4=-177/36,
1-6=-187/36
BOT CHORD 5-6=-47/81, 4-5=-45/87
WEBS 2-5=-21/144

NOTES
1) 2-ply truss to be connected together with 10d (0.131"x3") nails as follows:
Top chords connected as follows: 2x4 - 1 row at 0-9-0 oc.
Bottom chords connected as follows: 2x6 - 2 rows staggered at 0-9-0 oc.
Web connected as follows: 2x4 - 1 row at 0-9-0 oc.
2) All loads are considered equally applied to all plies, except if noted as front (F) or back (B) face in the LOAD CASE(S) section. Ply to ply connections have been provided to distribute only loads noted as (F) or (B), unless otherwise indicated.

- Wind: ASCE 7-16; Vult=130mph (3-second gust) Vasd=103mph; TCDL=6.0psf; BCDL=6.0psf; h=25ft; Cat. II; Exp B; Enclosed; MWFRS (envelope) exterior zone; cantilever left and right exposed ; end vertical left and right exposed; Lumber DOL=1.60 plate grip DOL=1.60
- TCLL: ASCE 7-16; Pr=20.0 psf (roof LL: Lum DOL=1.15 Plate DOL=1.15); Pf=20.0 psf (Lum DOL=1.15 Plate DOL=1.15); Is=1.0; Rough Cat B; Fully Exp.; Ce=0.9; Cs=1.00; Ct=1.10
- Unbalanced snow loads have been considered for this design.
- Provide adequate drainage to prevent water ponding.
- This truss has been designed for a 10.0 psf bottom chord live load nonconcurrent with any other live loads.
- * This truss has been designed for a live load of 20.0psf on the bottom chord in all areas where a rectangle 3-06-00 tall by 2-00-00 wide will fit between the bottom chord and any other members.
- Refer to girder(s) for truss to truss connections.
- Provide mechanical connection (by others) of truss to bearing plate capable of withstanding 141 lb uplift at joint 4.
- One H2.5A Simpson Strong-Tie connectors recommended to connect truss to bearing walls due to UPLIFT at jt(s) 6. This connection is for uplift only and does not consider lateral forces.
- This truss is designed in accordance with the 2018 International Residential Code sections R502.11.1 and R802.10.2 and referenced standard ANSI/TPI 1.
- Graphical purlin representation does not depict the size or the orientation of the purlin along the top and/or bottom chord.
- Use Simpson Strong-Tie LUS26 (4-10d Girder, 3-10d Truss, Single Ply Girder) or equivalent spaced at 2-0-0 oc max. starting at 3-5-0 from the left end to 5-5-0 to connect truss(es) to back face of bottom chord.
- Fill all nail holes where hanger is in contact with lumber.

LOAD CASE(S) Standard

- Dead + Snow (balanced): Lumber Increase=1.15, Plate Increase=1.15
Uniform Loads (lb/ft)
Vert: 1-2=-60, 2-3=-60, 4-6=-20
Concentrated Loads (lb)
Vert: 8=-824 (B), 9=-828 (B)

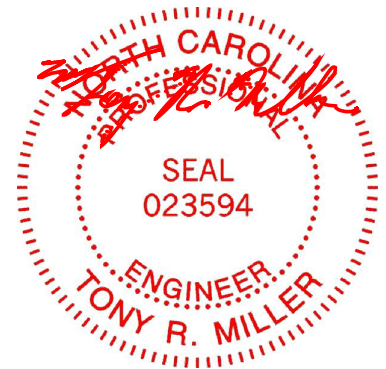

April 1, 2024

WARNING - Verify design parameters and READ NOTES ON THIS AND INCLUDED MITEK REFERENCE PAGE MII-7473 rev. 1/2/2023 BEFORE USE.

Design valid for use only with MiTek® connectors. This design is based only upon parameters shown, and is for an individual building component, not a truss system. Before use, the building designer must verify the applicability of design parameters and properly incorporate this design into the overall building design. Bracing indicated is to prevent buckling of individual truss web and/or chord members only. Additional temporary and permanent bracing is always required for stability and to prevent collapse with possible personal injury and property damage. For general guidance regarding the fabrication, storage, delivery, erection and bracing of trusses and truss systems, see **ANSI/TPI1 Quality Criteria and DSB-22** available from Truss Plate Institute (www.tpinst.org) and **BCSI Building Component Safety Information** available from the Structural Building Component Association (www.sbccomponents.com)

ENGINEERING BY
TRENCO
A MiTek Affiliate

818 Soundside Road
Edenton, NC 27932

Symbols

PLATE LOCATION AND ORIENTATION

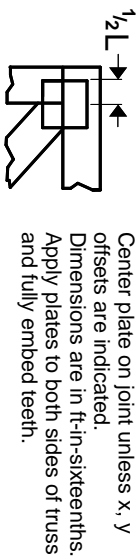

Center plate on joint unless x, y offsets are indicated. Dimensions are in ft-in-sixteenths. Apply plates to both sides of truss and fully embed teeth.

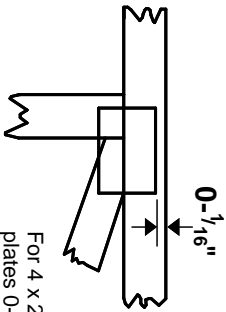

For 4 x 2 orientation, locate plates 0- $\frac{1}{16}$ \" from outside edge of truss.

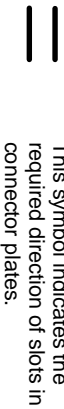

This symbol indicates the required direction of slots in connector plates.

* Plate location details available in MITek software or upon request.

PLATE SIZE

4 X 4

The first dimension is the plate width measured perpendicular to slots. Second dimension is the length parallel to slots.

LATERAL BRACING LOCATION



Indicated by symbol shown and/or by text in the bracing section of the output. Use T or I bracing if indicated.

BEARING

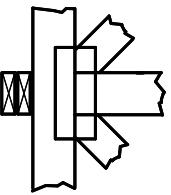

Indicates location where bearings (supports) occur. Icons vary but reaction section indicates joint number/letter where bearings occur. Min size shown is for crushing only.

Industry Standards:

ANSI/TP1: National Design Specification for Metal Plate Connected Wood Truss Construction.
DSB-22: Design Standard for Bracing.
BCSI: Building Component Safety Information, Guide to Good Practice for Handling, Installing, Restraining & Bracing of Metal Plate Connected Wood Trusses.

Numbering System



1 TOP CHORDS
2 JOINT ID TYP.

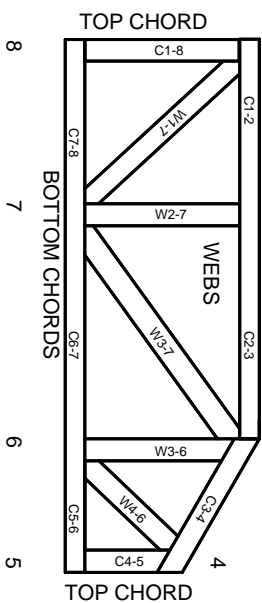

JOINTS ARE GENERALLY NUMBERED/LETTERED CLOCKWISE AROUND THE TRUSS STARTING AT THE JOINT FARTHEST TO THE LEFT.

CHORDS AND WEBS ARE IDENTIFIED BY END JOINT NUMBERS/LETTERS.

Product Code Approvals

ICC-ES Reports:

ESR-1988, ESR-2362, ESR-2685, ESR-3282
ESR-4722, ESL-1388

Design General Notes

Trusses are designed for wind loads in the plane of the truss unless otherwise shown.

Lumber design values are in accordance with ANSI/TP1 section 6.3. These truss designs rely on lumber values established by others.

© 2023 MITek® All Rights Reserved

General Safety Notes

Failure to Follow Could Cause Property Damage or Personal Injury

1. Additional stability/bracing for truss system, e.g. diagonal or X-bracing, is always required. See BCSI.
2. Truss bracing must be designed by an engineer. For wide truss spacing, individual lateral braces themselves may require bracing, or alternative Tor I bracing should be considered.
3. Never exceed the design loading shown and never stack materials on inadequately braced trusses.
4. Provide copies of this truss design to the building designer, erection supervisor, property owner and all other interested parties.
5. Cut members to bear tightly against each other.
6. Place plates on each face of truss at each joint and embed fully. Knots and wane at joint locations are regulated by ANSI/TP1 1.
7. Design assumes trusses will be suitably protected from the environment in accord with ANSI/TP1 1.
8. Unless otherwise noted, moisture content of lumber shall not exceed 19% at time of fabrication.
9. Unless expressly noted, this design is not applicable for use with fire retardant, preservative treated, or green lumber.
10. Camber is a non-structural consideration and is the responsibility of truss fabricator. General practice is to camber for dead load deflection.
11. Plate type, size, orientation and location dimensions indicated are minimum plating requirements.
12. Lumber used shall be of the species and size, and in all respects, equal to or better than that specified.
13. Top chords must be sheathed or purlins provided at spacing indicated on design.
14. Bottom chords require lateral bracing at 10 ft. spacing, or less, if no ceiling is installed, unless otherwise noted.
15. Connections not shown are the responsibility of others.
16. Do not cut or alter truss member or plate without prior approval of an engineer.
17. Install and load vertically unless indicated otherwise.
18. Use of green or treated lumber may pose unacceptable environmental, health or performance risks. Consult with project engineer before use.
19. Review all portions of this design (front, back, words and pictures) before use. Reviewing pictures alone is not sufficient.
20. Design assumes manufacture in accordance with ANSI/TP1 1 Quality Criteria.
21. The design does not take into account any dynamic or other loads other than those expressly stated.

MITek

ENGINEERING BY
TRENGO
A MITek Affiliate

MITek Engineering Reference Sheet: MIL-7473 rev. 1/2/2023