

Harnett County Environmental Health

File/Permit Number: SFD2404-0011

IMPROVEMENT PERMIT

County: Harnett

PIN/Lot Identifier: 9692-70-1192.000

Owner: HHHunt Homes

Applicant: Scott Mitchell

Property Location: 996 Hollies Pines Rd

Subdivision (if applicable) _____ Lot #: _____ Block: _____ Section: _____

New Expansion System Relocation Change of Use

Facility Type: SFD (35'x38')

Number of bedrooms: 3 Number of Occupants: 6 Other: _____

Design Wastewater Strength: Domestic High Strength Industrial Process Wastewater

Proposed Design Daily Flow: 360 GPD Proposed LTAR (Initial): .3 Proposed LTAR (Repair): .3

Proposed Wastewater System Type*: 10" Large Diameter Pipe (Initial) Pump Required: Yes No May be required

Proposed Wastewater System Type*: Horizontal Panel Block (Repair) Pump Required: Yes No May be required

**Please include system classification for proposed wastewater system types in accordance with Rule .1301 Table XXXII*

Effluent Standard: DSE HSE NSF/ANSI 40 TS-I TS-II RCW

Saprolite System (Initial): Yes No Saprolite System (Repair): Yes No

Fill System (Initial): Yes No If yes, specify: New Existing (when adding more than 6 inches of fill to system area provide a fill plan)

Fill System (Repair): Yes No If yes, specify: New Existing (when adding more than 6 inches of fill to system area provide a fill plan)

Usable Depth to LC (Initial)*: 36 Usable Depth to LC (Repair)*: 36 ** Limiting Condition*

Max. Trench Depth (Initial)*: 18 Max. Trench Depth (Repair)*: 18 ** Measured on the downhill side of the trench*

Artificial Drainage Required: Yes No If yes, please specify details: _____

Type of Water Supply: Private well Public well Shared well Municipal Supply Spring Other: _____

Drainfield location meets requirements of Rule .0508: Yes No Drainfield location meets requirements of Rule .0601: Yes No

Permit valid for: Five years [site plan submitted pursuant to GS 130A-334(13a)] No expiration [plat submitted pursuant to GS 130A-334(7a)]

Permit conditions:

Authorized Agent's Printed Name: Oliver Tolksdorf

Expiration Date: 5/8/29

Authorized Agent's Signature: 

Date: 5/8/24

See attached site sketch

The issuance of this permit in no way guarantees the issuance of other permits. The permit holder is responsible for checking with appropriate governing bodies in meeting their requirements. This permit is subject to revocation if the site plan, plat, or the intended use changes. The Improvement Permit shall not be affected by a change in ownership of the site. This permit is subject to compliance with the provisions of 15A NCAC 18E and to the conditions of this permit.

Harnett County Environmental Health

File/Permit Number: SFD2404-0011

CONSTRUCTION AUTHORIZATION

County: Harnett PIN/Lot Identifier: 9692-70-1192.000
Owner: HHHunt Homes Applicant: Scott Mitchell
Property Location: 996 Hollies Pines Rd
Facility Type: SFD (35'x38')

Number of bedrooms: 3 Number of Occupants: 6 Other: _____

New Expansion Repair System Relocation Change of Use

Basement? Yes No Basement Fixtures? Yes No

Crawl Space? Yes No Slab Foundation? Yes No

Type of Wastewater System* 10" Large Diameter Pipe (Initial) Horizontal Panel Block (Repair)

*Please include system classification for proposed wastewater system types in accordance with Rule .1301 Table XXXII

Design Daily Flow: 360 GPD Wastewater Strength: Domestic High Strength Industrial Process Wastewater

Rule .0403(e) Engineering Design Utilizing Low-flow Fixtures and Low-flow Technologies (S.L. 2013-413 and 2014-120)? Yes No
(if yes, please provide engineering documentation)

Effluent Standard: DSE HSE NSF/ANSI 40 TS-I TS-II RCW

Type of Water Supply: Private well Public well Shared well Municipal Supply Spring Other: _____

Installation Requirements/Conditions

Septic Tank Size: 1000 gallons Total Trench/Bed Length: 660 feet Trench/Bed Spacing: 6 feet on center

Trench/Bed Width: 1 inches LTAR: .3 gpd/ft² Usable Depth to LC (Initial)*: 36 *Limiting condition

Soil Cover: 6 inches Slope Corrected Maximum Trench/Bed Depth[†]: 18 inches * Measured on the downhill side of the trench

Pump Tank Size (if applicable): _____ gallons Requires more than one pump? Yes No

Pump Requirements: _____ ft. TDH vs. _____ GPM Grease Trap Size (if applicable): _____ gallons

Distribution Method: Serial D-Box or Parallel Pressure Manifold(s) LPP Other: w/ Flow Dividers

Artificial Drainage Required: Yes No If yes, please specify details: _____

Legal Agreements (If the answer is "Yes" to any type of legal agreements, please attach a copy of the agreement.)

Multi-party Agreement Required [Rule .0204(g)]: Yes No

Easement, Right-of-Way, or Encroachment Agreement Required [Rule .0204(d)]: Yes No

Declaration of Restrictive Covenants: Yes No Pre-Construction Conference Required: Yes No

Management Entity Required: Yes No Minimum O&M Requirements: _____

Conditions: CA based on proposal from applicants LSS

The requirements of 15A NCAC 18E are incorporated by reference into this permit and shall be met. Systems shall be installed in accordance with the attached site sketch. **This Construction Authorization is subject to revocation if the site plan, plat, or the intended use changes.** The Construction Authorization shall not be affected by a change in ownership of the site. This Construction Authorization is subject to compliance with the provisions of 15A NCAC 18E, or 15A NCAC 18A .1900, as applicable, and to the conditions of this permit.

Authorized Agent's Printed Name: Oliver Tolksdorf Expiration Date: 5/8/29

Authorized Agent's Signature: _____ Date: 5/8/24

See attached site sketch

Mitchell Environmental, P.A.

SEPTIC SYSTEM DESIGN

for

HOLLIES PINES- LOT 4

Broadway, Harnett County, North Carolina

Submitted to:

Harnett County Health Department
307 Cornelius Harnett Blvd.
Lillington, NC 27546

Prepared for:

HHHunt Homes
1 Fenton Main Street
Suite 280
Cary, North Carolina 27511

Prepared by:

Adam Aycock, EI

DATE: March 22, 2024

PROJECT NO.: 1922



Harnett County GIS

PID: 139692 0014 92
PIN: 9692-70-1192.000
Account Number: 1500051599
Owner: HHHUNT HOMES RALEIGH-DURHAM LLC
Mailing Address: 11237 NUCKOLS RD GLEN ALLEN, VA 23059-5502
Physical Address: 996 HOLLIES PINES RD BROADWAY, NC 27505 ac
Description: LOT#4 PINEDAROSA 1 MAP#2020-109
Surveyed/Deeded Acreage: 0.57
Calculated Acreage: 0.58
Deed Date: 1662008400000
Deed Book/Page: 4165 - 0651
Plat(Survey) Book/Page: 2020 - 109
Last Sale: 2022 - 9
Sale Price: \$240000
Qualified Code: A
Vacant or Improved: V
Transfer of Split: T
Actual Year Built:
Heated Area : SqFt
Building Count : 0

Building Value: \$0
Parcel Outbuilding Value: \$0
Parcel Land Value: 20460
Market Value: \$20460
Deferred Value: \$0
Total Assessed Value: \$20460
Zoning: RA-30 - 0.58 acres (100.0%)
Zoning Jurisdiction: Harnett County
Wetlands: No
FEMA Flood: Minimal Flood Risk
Within 1mi of Agriculture District: Yes
Elementary School: Boone Trail Elementary
Middle School: Western Harnett Middle
High School: Western Harnett High
Fire Department: Boone Trail
EMS Department: Medic 12, D12 EMS
Law Enforcement: Harnett County Sheriff
Voter Precinct: Boone Trail
County Commissioner : Lewis Weatherspoon
School Board Member: Duncan Jagers



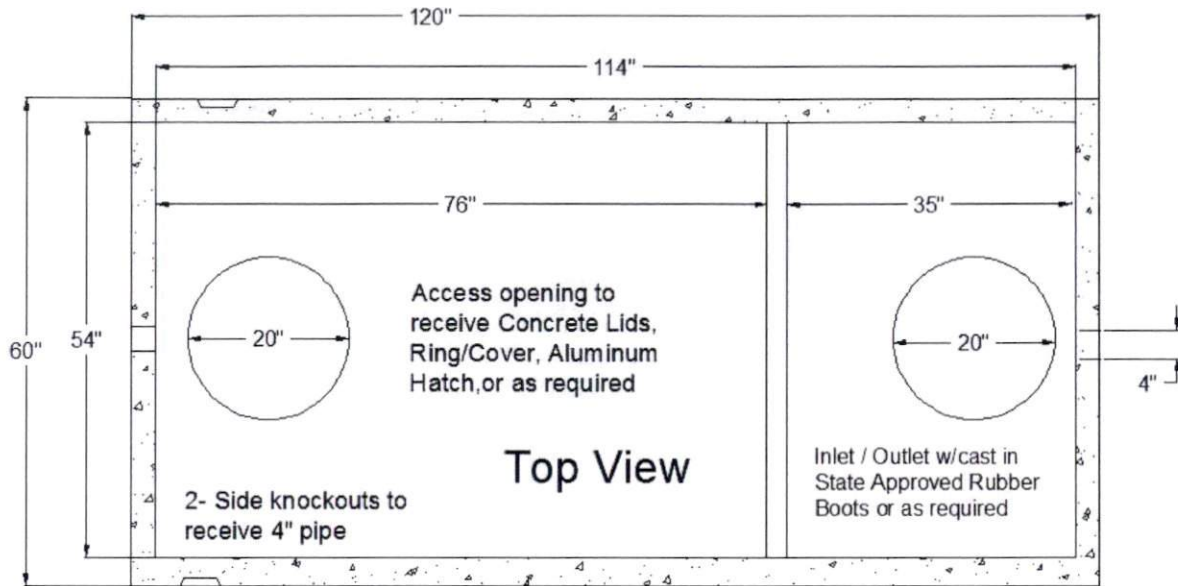

STB - 345 - Top Seam

Approval Date: 12 - 09 - 99

Liquid Capacity 1007 Gallons

Non Traffic Rated

Reinforcing Schedule: # 3 Grade 60 Rebar

4500 PSI Concrete w/ State Approved Structural Fiber

Est. Weight: 8,200 lbs.

Manufactured By:

GARNERS

Septic Tanks, Inc.

Eddie Garner, President

919-718-5181

121 Stanton Hill Road

Carthage, NC 28327

Fax 919-775-2229

Eddie@garnersseptic tanks.com

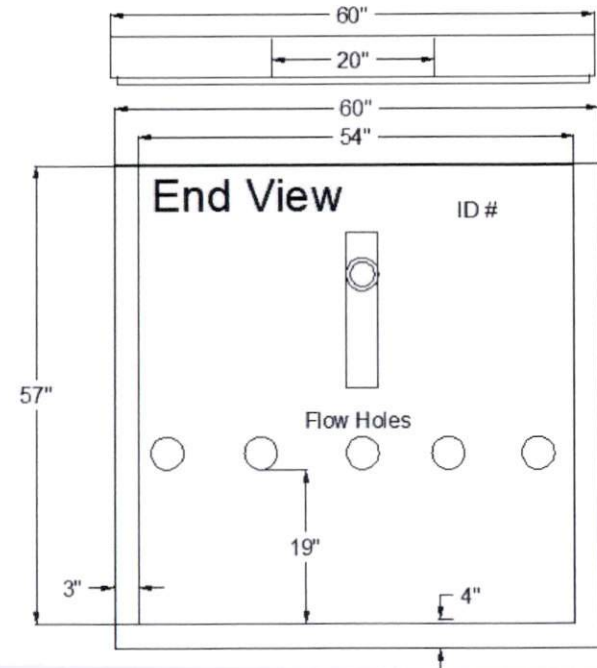
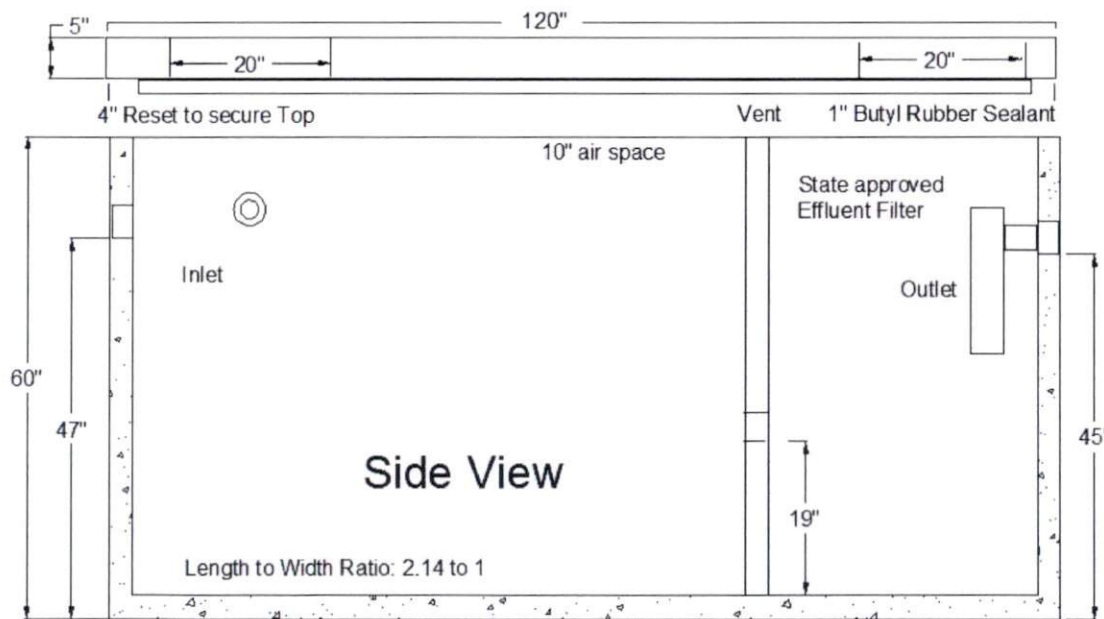

PL-68 Filter and Tee

PL-68 is much more than just an effluent filter. The housing can also be used as an inlet baffle (tee) or an outlet baffle. The housing is designed to accept Polylok's snap in gas deflector to deflect gas bubbles away from the tee and to keep the solids in the tank.

Features:

- Offers 68 linear feet of 1/16" filter slots, which significantly extends time between cleaning.
- Accepts 3/4" PVC handle.
- Locks in any 360° position when used with PL-68 Tee.
- PL-68 Housing can be used as an inlet or outlet tee.
- Gasket prevents bypass.

PL-68 Installation:

Ideal for residential waste flows up to 800 gallons per day (GPD). Easily installs in any new or existing 4" outlet tee.

1. Locate the outlet of the septic tank.
2. Remove the tank cover and pump tank if necessary.
3. Glue the filter housing to the outlet pipe, or use a Polylok Extend & Lok if not enough pipe exists.
4. Insert the PL-68 filter into tee.
5. Replace and secure the septic tank cover.

PL-68 Maintenance:

The PL-68 Effluent Filter will operate efficiently for several years under normal conditions before requiring cleaning. It is recommended that the filter be cleaned every time the tank is pumped, or at least every three years.

1. Do not use plumbing when filter is removed.
2. Pull PL-68 out of the tee.
3. Hose off filter over the septic tank. Make sure all solids fall back into septic tank.
4. Insert filter back into tee/housing.

Related Products:

PL-68 Filter Concrete Baffle
 Extend & Lok™

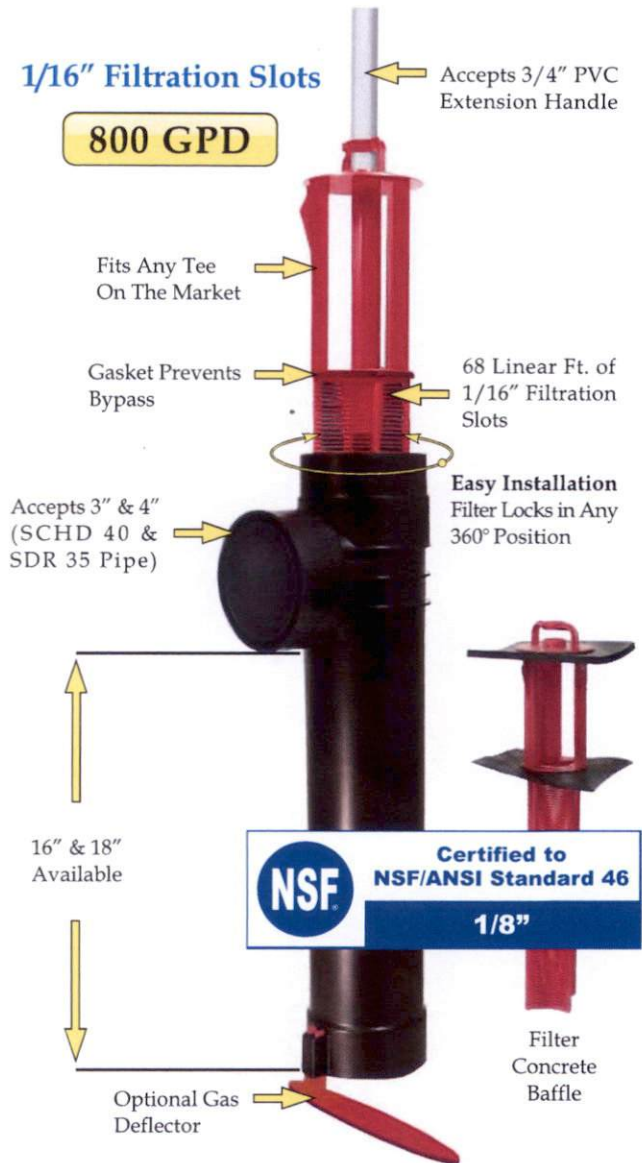

Extend & Lok™
 Easily installs
 into existing tanks.



Spacer Bushing
 4" SCHD 40
 to SDR 35



Spacer Bushing
 4" SCHD 40
 to 110mm Pipe



2" Extender

POLYLOK FLOW CONTROLLER
 PART NO. 3051
 MATERIAL - ABS

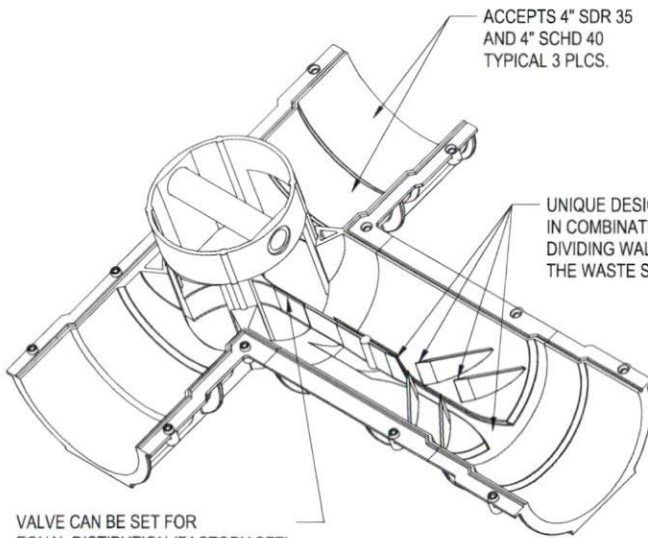
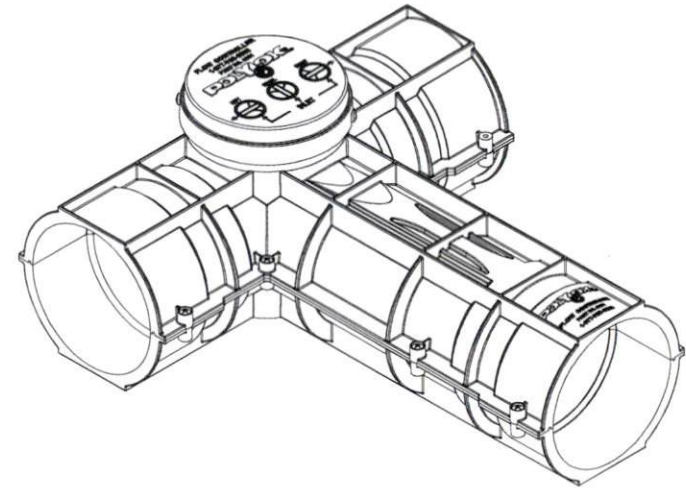
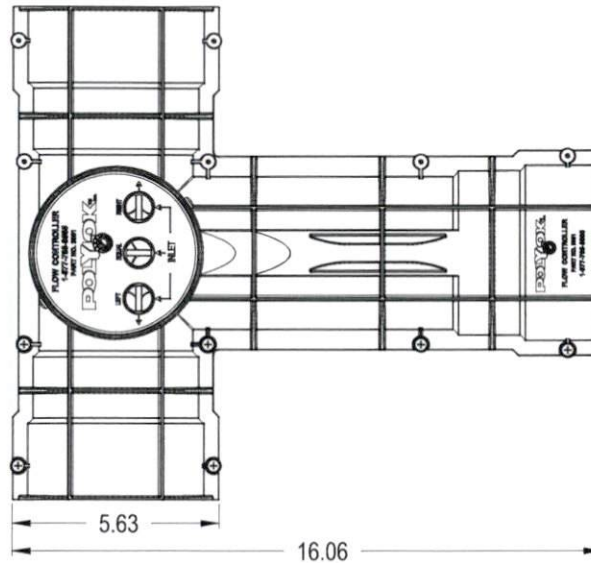

UNIQUE DESIGN USING A DOUBLE SET OF VEINS
 IN COMBINATION WITH A CHANNEL SPLIT BY A
 DIVIDING WALL. THIS ENABLES AN EQUAL SPLIT OF
 THE WASTE STREAM, EVEN AT A 2% SHIFT IN SOIL.

VALVE CAN BE SET FOR
 EQUAL DISTRIBUTION (FACTORY SET)
 ALL DISTRIBUTION RIGHT
 ALL DISTRIBUTION LEFT

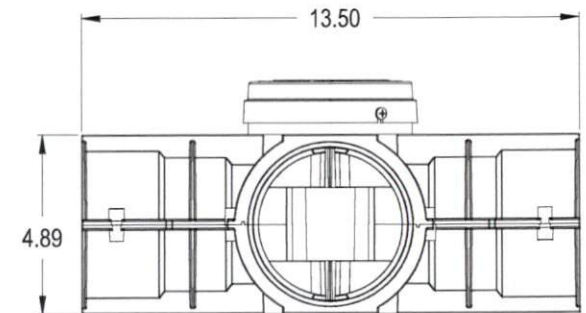
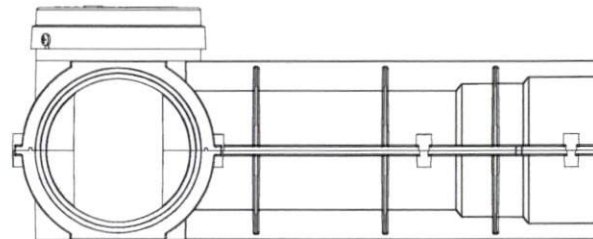

Crumpler's No-Rock™ Fabric Wrapped Large Diameter (LDP) Septic Pipe

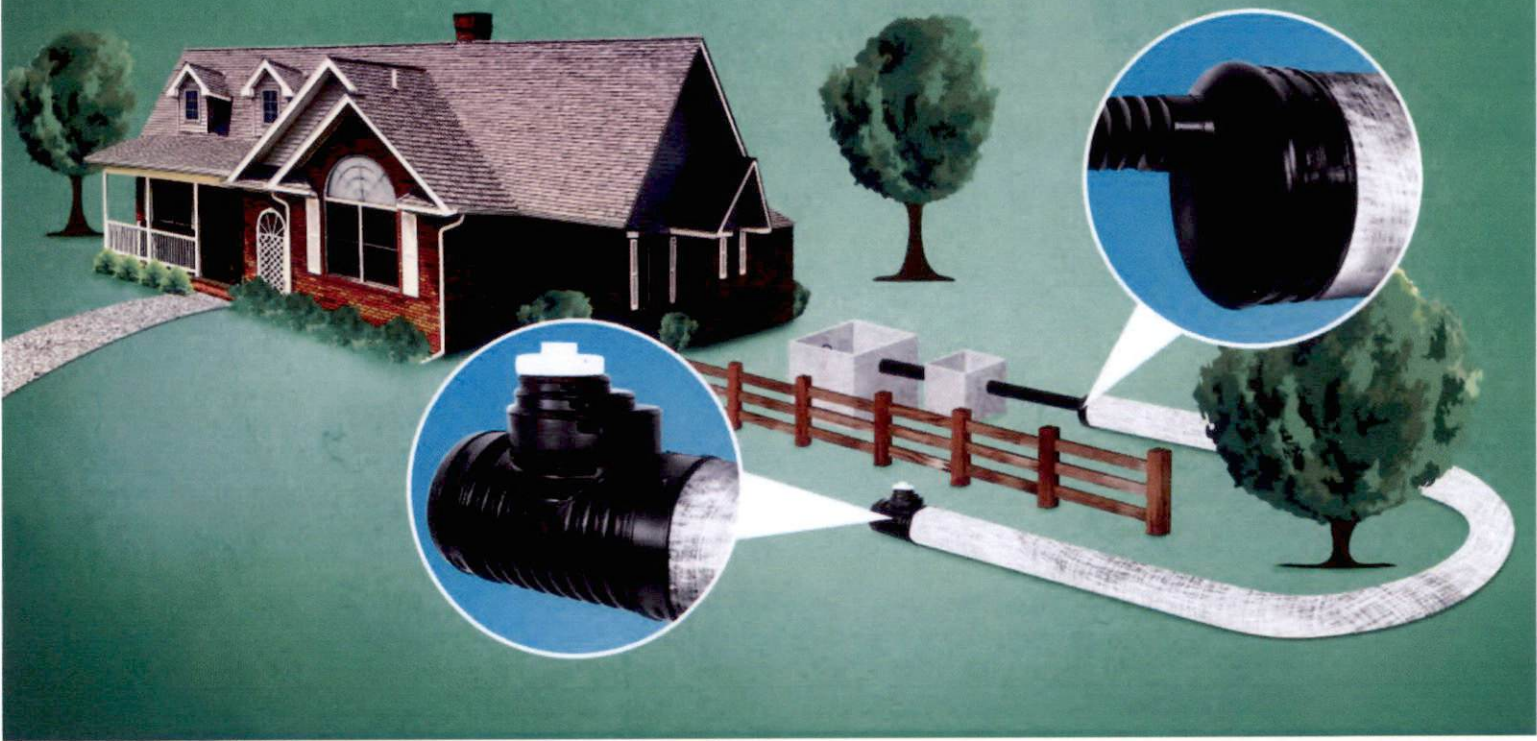

Crumpler Plastic Pipe, Inc.

Manufacturers of Corrugated Plastic Drainage Pipe

Phone 910-525-4046 / (800) 334-5071

Post Office Box 2068

Roseboro, North Carolina 28382

Web Site: www.cpp-pipe.com





Crumpler's No-Rock™ Fabric Wrapped Large Diameter (LDP) Septic Pipe

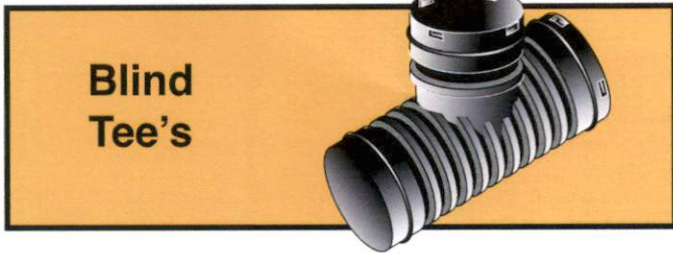

Blind Tee's

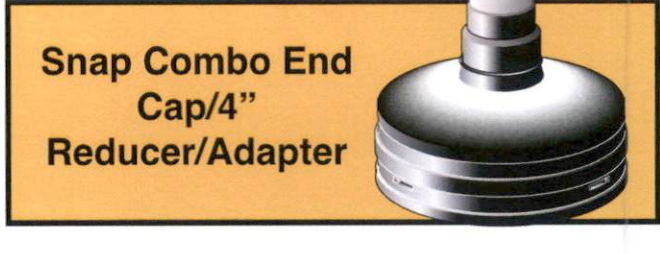

Snap Combo End Cap/4\"/>

CPP Gravelless LDP Trench Construction Details

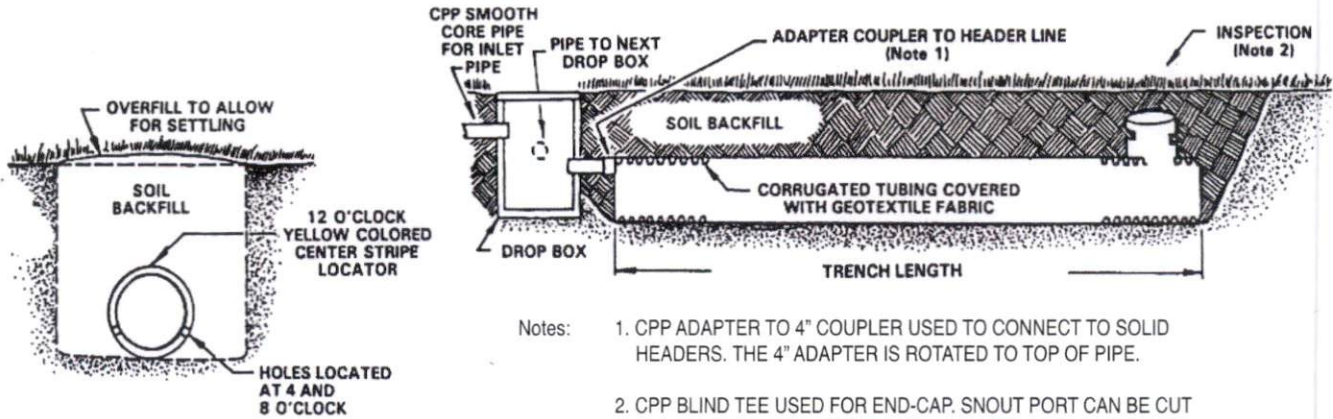

- Notes:
1. CPP ADAPTER TO 4" COUPLER USED TO CONNECT TO SOLID HEADERS. THE 4" ADAPTER IS ROTATED TO TOP OF PIPE.
 2. CPP BLIND TEE USED FOR END-CAP. SNOOT PORT CAN BE CUT OUT FOR INSTALLING A CLEAN OUT ADAPTER THAT ALLOWS FOR POST INSTALLATION INSPECTION.



TYPE	SIZE	PART NO.	PACKAGE DESCRIPTION	PRICE
	8"	0830020B	CRUMPLER'S NO-ROCK™ SEPTIC - 20 ft. with filter wrap	
	10"	1030020B	CRUMPLER'S NO-ROCK™ SEPTIC - 20 ft. with filter wrap	

Large diameter (LDP) CPP GRAVELLESS septic tank trench systems use a filter wrap that allows for the installation of septic treatment pipes without gravel. The advantage in using CPP NO-ROCK is evident in areas where there is a shortage of inexpensive quality rock or where the shape and topography of a lot hinder the access of heavy construction equipment. Less equipment use means more trees can be saved,



less lot grading is needed, and thus fuel and labor are saved. Additionally, narrow trenches for 8" and 10" CPP pipes create a reduced OC (On-Center) Spacing between parallel septic trenches. An 8" CPP pipe can fit in a 10" wide trench and a 10" CPP pipe in a 12" wide trench. Thus Lot space is saved for other uses.

- Eliminates Rock
- Saves On Lot Grading
- Saves Trees On Lot
- Saves on Installation Labor
- Saves Fuel
- Increases Lot Value



Crumpler's No-Rock™ Fabric Wrapped Large Diameter (LDP) Septic Pipe



	TYPE	SIZE	PART NO.	PACKAGE DESCRIPTION	PRICE
		8"	0830020B	CRUMPLER'S NO-ROCK™ SEPTIC - 20 ft. with filter wrap	
		10"	1030020B	CRUMPLER'S NO-ROCK™ SEPTIC - 20 ft. with filter wrap	

Large diameter GRAVELLESS septic tank trench systems were developed as an alternative to 4" pipe systems in gravel-filled trenches for use in soils that most conventional 4" gravel would be allowed in. Organic Iron Ochre soils, however, are unsuitable for Filter Enclosed Gravelless Septic Pipes. The advantage in using the large diameter systems is evident in areas where there is a shortage of inexpensive quality rock, or where the shape and topography of a lot hinder the access of heavy construction equipment. The use of small trenches for digging narrow trenches means more trees can be saved, less grading is needed, and thus fuel and labor are saved.

Crumpler's NO-ROCK™ septic systems include using either an 8" or a 10" corrugated HDPE pipe enclosed in a polypropylene filter wrap. ASTM-F-481 septic installation specification should be reviewed prior to installation. **Most states allow GRAVELLESS large diameter systems to be substituted for conventional systems in ANY SOIL TYPE deemed acceptable for a**

conventional system. One should check with local septic inspectors for locally approved soils.

Crumpler's NO-ROCK™ septic system may be substituted for any conventional 4" pipe gravel trench system utilizing distribution devices, serial distribution, hillside or stepdowns. However, it should not be substituted for bed systems. It should also be limited to domestic sewage, and not used where there will be large amounts of grease or oil such as in restaurants unless designed by an engineer.

The 8" size pipe will equal to 2-foot wide conventional trench; and the 10" size will equal a 2.5 foot wide trench. To determine the required linear footage of either pipe size, first determine the square footage by dividing the design sewage flow by the appropriate soil's long term application rate. Then divide this total square footage area figure by either 2 feet (for 8") or 2.5 feet (for 10") to establish the linear footage amount. Per chart below, on center (oc) spacing will be determined by actual trench width.

Example: A 3-bedroom house on a loam soil
0.6 gpd/ft² = loam soil's long term application rate.

$$3BR \times 120 \text{ gpd} = 360 \text{ gpd}$$

$$360 \text{ gpd} \div 0.6 \text{ gpd/ft}^2 = 600 \text{ ft.}$$

$$600 \text{ ft}^2 \div 2 \text{ ft} = 300 \text{ linear ft of 8" or}$$

$$600 \text{ ft}^2 \div 2.5 \text{ ft} = 240 \text{ linear ft of 10"}$$

$$600 \text{ ft}^2 \div 3 \text{ ft} = 200 \text{ ft for conventional 4" gravel}$$

SUGGESTED INSTALLATION OF STANDARDS

Nitrification trench bottom minimum width for 8".....	10"
Nitrification trench bottom minimum width for 10".....	12"
Nitrification line center spacing on 8".....	5' oc
Nitrification line center spacing on 10".....	6' oc
Nitrification trench bottom minimum depth.....	18"
Nitrification trench bottom maximum depth (24" preferred).....	36"
Nitrification trench bottom slope.....	level to 1" per 100 ft
Nitrification line minimum cover.....	6"
Nitrification line maximum cover (12" preferred).....	24"

To eliminate voids and clods under pipes 15" - 18" trenches is recommended unless sand backfill is used.

The corrugated pipe used shall comply with ASTM-F-667. Also the installer should be careful to note that the filter wrap is light

sensitive, and should not be exposed to sunlight for extended periods of time. The installer should also take care during installation to avoid tearing of the filter material. The protective plastic wrap that protects the filter should be disposed of off site.

WEB SITE: www.cpp-pipe.com / E-Mail: cppsales@cpp-pipe.com

(800) 334-5071
TOLL FREE USA/CANADA

OUR PIPE IS LABORATORY TESTED

(910) 525-5801
24 HOUR FAX SERVICE



Slope Correction Table



NOTE: Add the inches from Slope Table to the MSD¹ to determine the RSD²

PERCENT SLOPE	10" Trench	12" Trench	18" Trench	24" Trench	36" Trench
6	0.6	0.7	1.1	1.4	2.2
12	1.2	1.4	2.2	2.9	4.3
18	1.8	2.2	3.2	4.3	6.5
24	2.4	2.9	4.3	5.8	8.6
30	3	3.6	5.4	7.2	10.8
36	3.6	4.3	6.5	8.6	13.0
42	4.2	5.0	7.6	10.1	15.1
48	4.8	5.8	8.6	11.5	17.3
54	5.4	6.5	9.7	13.0	19.4
60	6	7.2	10.8	14.4	21.6

NOTE: For sloping sites a calculation of the additional required soil depth is necessary using the table above or the following formula: $RSD = MSD + (TW \times .S)$

Where; RSD = Required Soil Depth (inches),

MSD - Min. Soil Depth (Min. Soil Cover + Ht. of Sys. + Min. Separation) (in)

TW = Trench Width (inches), &

.S = Percent Slope (.00)

Example: Assume site for septic system dispersal field has a slope of 28% and the trench bottom is required to be 12 inches above a site limitation, such as, weathered rock or perched water table. Also, assume that the proposed site has a usable or acceptable soil depth of 38 inches. Further, a minimum soil cover of 6 inches is required over the dispersal system.

- Trial 1:** Conventional trench (36 inches wide, 12 inches gravel, 6 inches over) would require a usable soil depth of 40 inches. [40 inches RSD - 30 inches MSD + (36 inches TW x .28 S)] Thus, a conventional or 36 inch wide trench is unsuitable at this site.
- Trial 2:** Crumpler NO ROCK™ 8 inch ID (10 in. OD) installed in a 12 inch wide trench would require a usable soil depth of 31.4 inches. [31.4 RSD = 28 inches MSD + (12 inches TW x .28 S)] Therefore, site is acceptable for Crumpler 8 in. NO ROCK™.
- Trial 3:** Crumpler NO ROCK™ 10 inch ID (12 in. OD) installed in an 18 inch wide trench would require a usable soil depth of 35 inches. [35 inches RSD = 30 inches MSD + (18 inches TW x .28 S)] Therefore, site is acceptable for Crumpler 10 inch NO ROCK™.

¹ MSD is the minimum soil depth at 0% slope and is the sum of the min. separation distance between trench bottom and limiting horizon (typ. 12 in), plus the system height, plus the min. soil cover (typ. 6 in.).

² RSD is the required soil depth to install a trench on a sloping site with the added inches to meet the minimum separation distance on the uphill side of the trench.



Septic Effluent Disposal Trenches on Sloping Sites (Cross Section View)

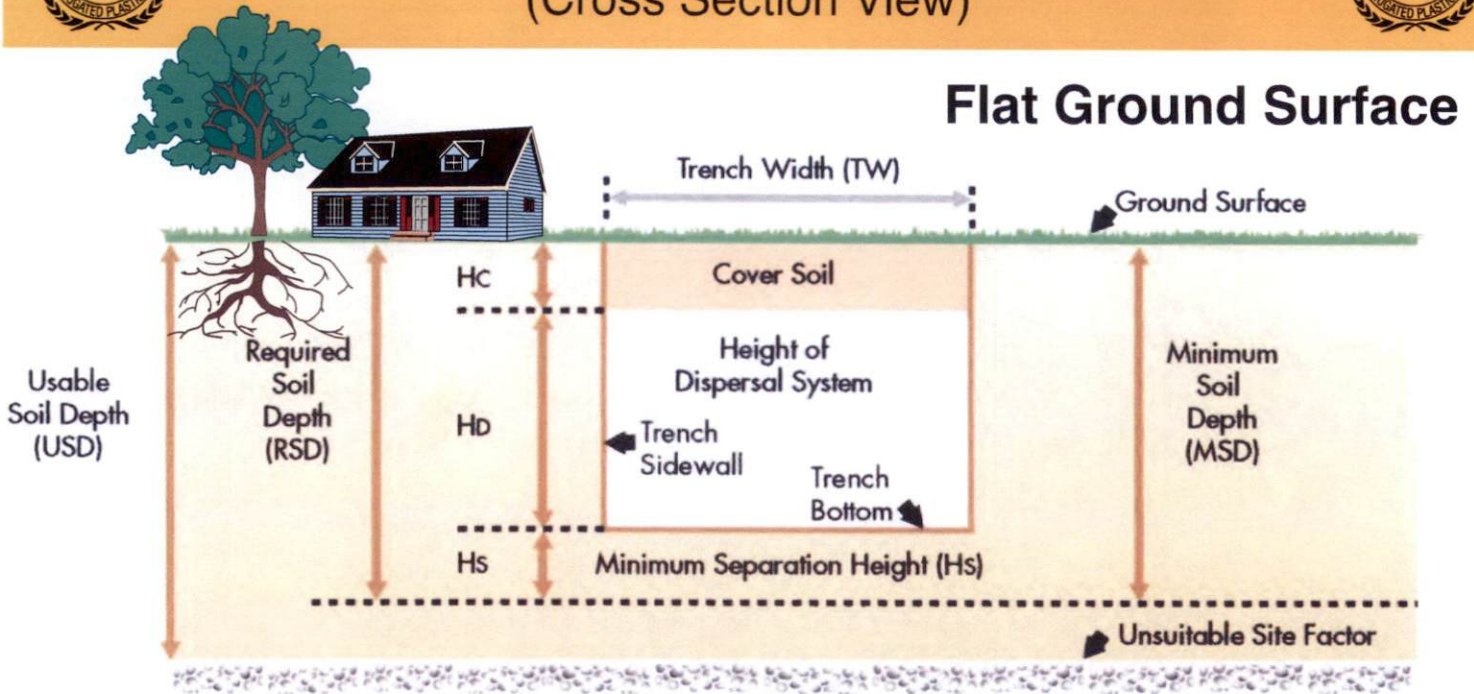

$$\text{MSD} = H_c + H_d + H_s$$
$$\text{MSD} = \text{RSD on Flat Sites}$$

Not To Scale

FIGURE 1

Sloping ground Surface

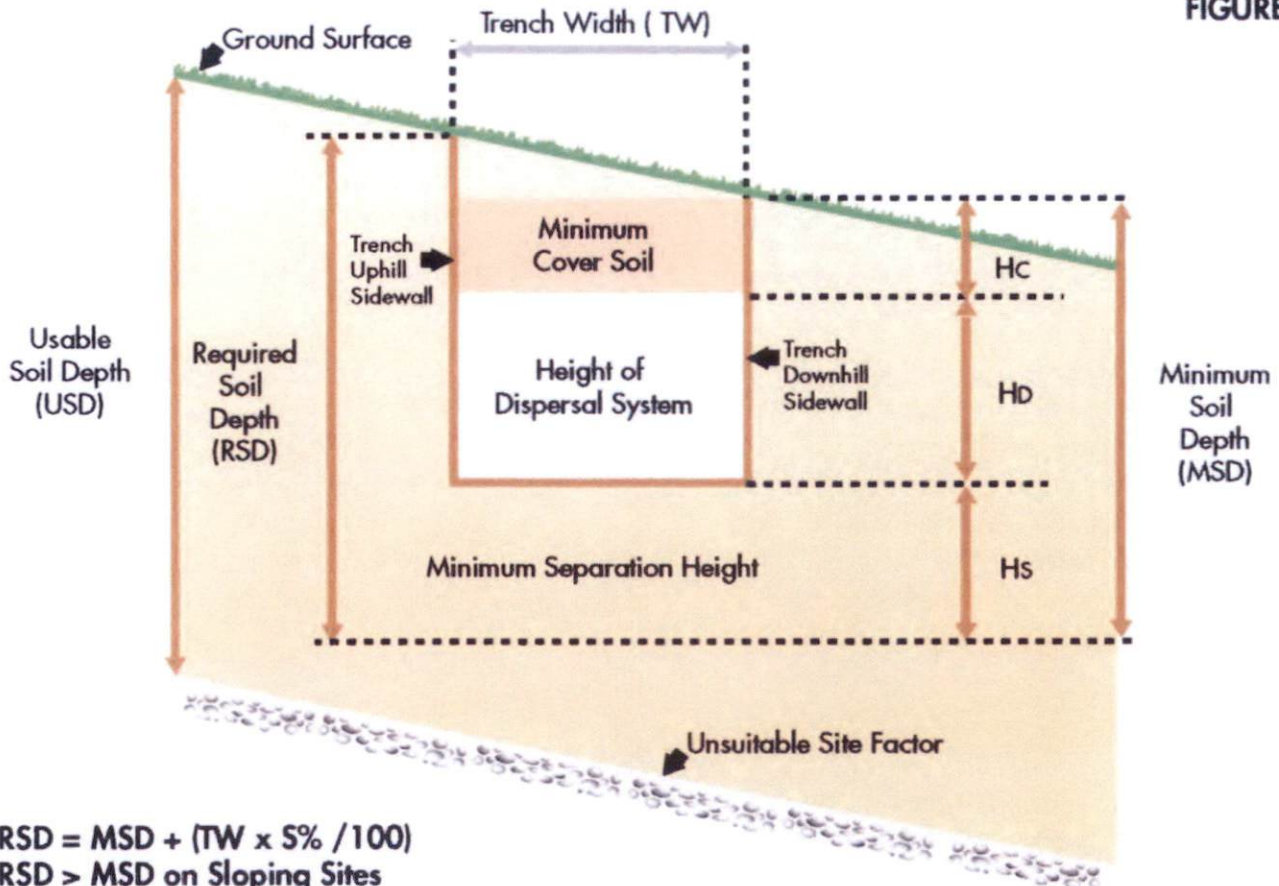
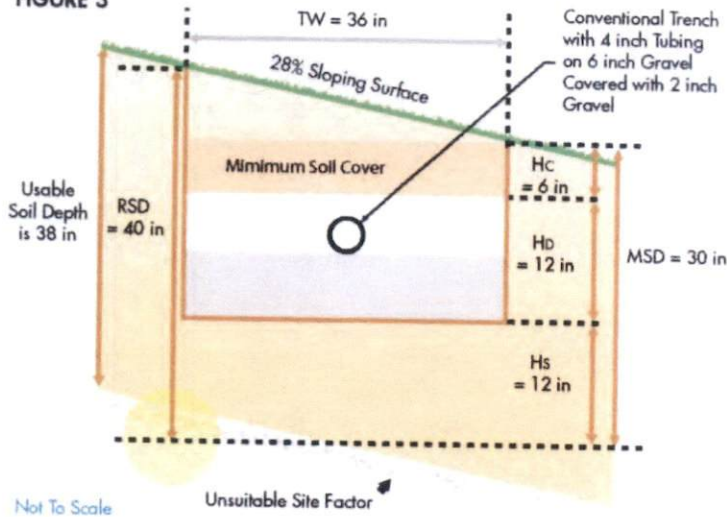

FIGURE 2

$$\text{RSD} = \text{MSD} + (\text{TW} \times 5\% / 100)$$
$$\text{RSD} > \text{MSD on Sloping Sites}$$
$$\text{USD} \geq \text{RSD}$$

Not To Scale

FIGURE 3



Septic Effluent Disposal Trenches on Sloping Sites (Cross Section) Trial No. 1

Site has 28% slope and soil is 38 inches deep

Trial No. 1: Use 36 inch wide conventional trench system

$$\text{MSD} = 6 \text{ in} + 12 \text{ in} + 12 \text{ in} = 30 \text{ inches}$$

$$\text{RSD} = 30 \text{ in} (36 \text{ in} \times 28\%/100) = 40 \text{ inches}$$

$$\text{RSD (40 in)} > \text{USD (38 in)}$$

Proposed System **Unsuitable** for Slope

Septic Effluent Disposal Trenches on Sloping Sites (Cross Section) Trial No. 2

Site has 28% slope and soil is 38 inches deep

Trial No. 2: Use CPP 8 inch NO-ROCK™ with 12 inch wide trench.

$$\text{MSD} = 6 \text{ in} + 10 \text{ in} + 12 \text{ in} = 28 \text{ inches}$$

$$\text{RSD} = 30 \text{ in} (12 \text{ in} \times 28\%/100) = 31.4 \text{ inches}$$

$$\text{USD (38 in)} > \text{RSD (31.4 in)}$$

Proposed **CPP 8 inch NO-ROCK™** Suitable for Slope

FIGURE 4

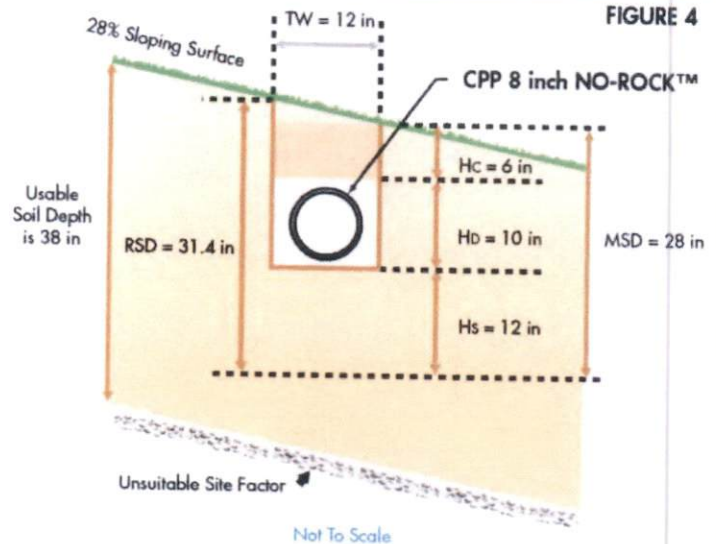
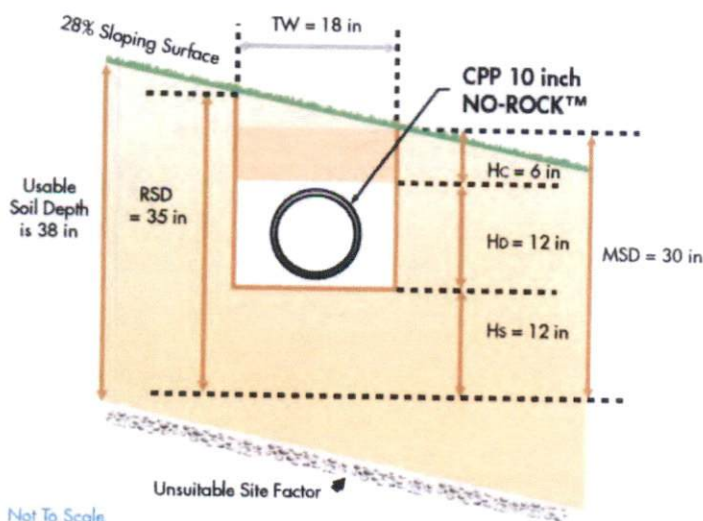

FIGURE 5



Septic Effluent Disposal Trenches on Sloping Sites (Cross Section) Trial No. 3

Site has 28% slope and soil is 38 inches deep

Trial No. 3: Use CPP 10 inch NO-ROCK™ with 18 inch wide trench.

$$\text{MSD} = 6 \text{ in} + 12 \text{ in} + 12 \text{ in} = 30 \text{ inches}$$

$$\text{RSD} = 30 \text{ in} (18 \text{ in} \times 28\%/100) = 35 \text{ inches}$$

$$\text{USD (38 in)} > \text{RSD (35 in)}$$

Proposed **CPP 10 inch NO-ROCK™** Suitable for Slope



Crumpler's No-Rock™ Fabric Wrapped Large Diameter (LDP) Septic Pipe



1 NC State University layout of CPP No-Rock Septic at the Ed Booth field Learning Lab.



2 Laser Level adjustment setting prior to trenching sequence.



3 Laser Level check of trench depth grade and bag encased protected pipe moved onto trench site. The plastic bags protect the filter wrap from extended storage UV deterioration and natural handling abuses.



4 Protective plastic bags removed just prior to trench placement.



5 Protective plastic bags removed from the site for disposal elsewhere.



6 Trenching complete, and ready for Side-Wall rake prep sequence.



7 CPP No-Rock Septic pipes allow for narrow trenches that offer a closer OC spacing, which requires a reduced land area footprint compared to conventional 3-foot wide trenches.



8 A Blind Tee with a screw off Clean Out Plug is placed at the end of each individual line. This allows for a line inspection.



9 Final cover sequence begins.



10 Narrow trenches allow for faster, less cumbersome of equipment about the site during the final cover phase, and this saves equipment time on the job.

To Spec (HDPE) Corrugated Plastic Pipe Spec as:

ASTM General Construction

CPP-ASTM-F-677 (3" - 24")

CPP-ASTM-F-2306 (12" - 60")

CPP-ASTM-F-2648 (2"-60")

AASHTO Highway Construction

CPP-AASHTO-M-252 (3" - 10")

CPP-AASHTO-M-294 (12" - 60")

OUR PIPE IS LABORATORY TESTED



PHONE 910-525-4046 / (800) 334-5071

24 HR. FAX SERVICE (800) CPP-PIPE

WEB SITE: www.cpp-pipe.com

The East Coast's Largest Producer Under One Roof



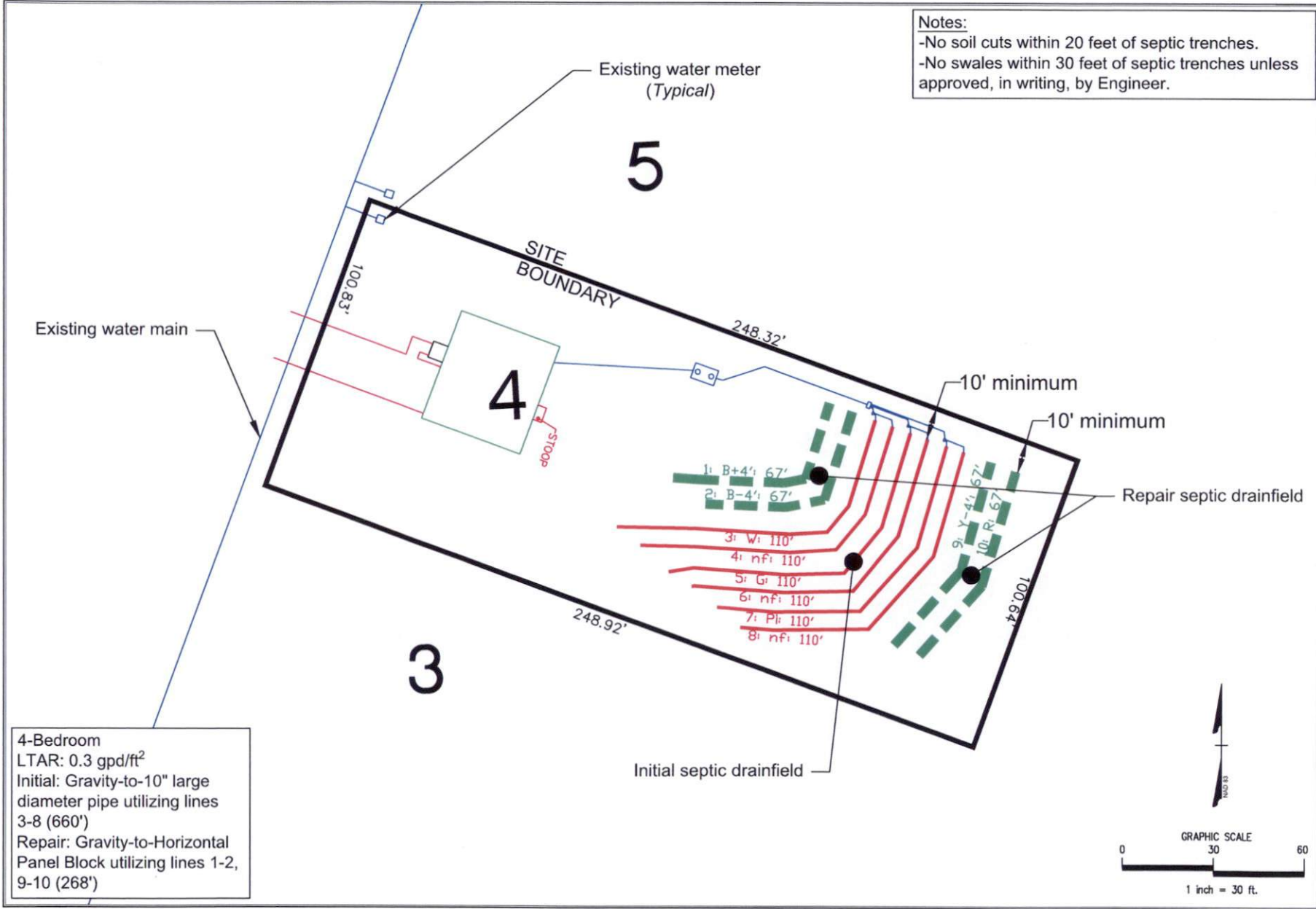

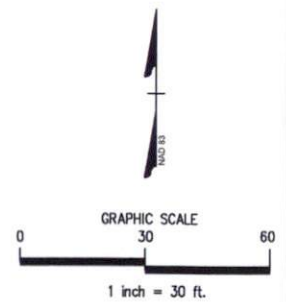

4-Bedroom
 LTAR: 0.3 gpd/ft²
 Initial: Gravity-to-10" large diameter pipe utilizing lines 3-8 (660')
 Repair: Gravity-to-Horizontal Panel Block utilizing lines 1-2, 9-10 (268')

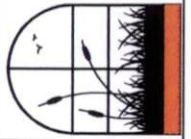

MITCHELL ENVIRONMENTAL, PA C-2917 1501 LAKESTONE VILLAGE LANE SUITE 205 FUQUAY VARINA, NC 27526	PREPARED FOR : HHS&T Home of Raleigh 10000 W. Cary Rd., Suite 108 Raleigh, NC 27617	REVISION NO. Original Submittal Revision 1 Revision 2 Revision 3 Master Set	SHEET NUMBER 1 of 5
	DATE : March 22, 2024 DESIGNER CONTACT : ADAM AYCOCK, EIT DRAWN BY : ADAM AYCOCK, EIT	DATE : March 22, 2024 DESIGNER CONTACT : ADAM AYCOCK, EIT DRAWN BY : ADAM AYCOCK, EIT	DATE : March 22, 2024 REVISION NO. : Original Submittal REVISION 1 : REVISION 2 : REVISION 3 : MASTER SET :

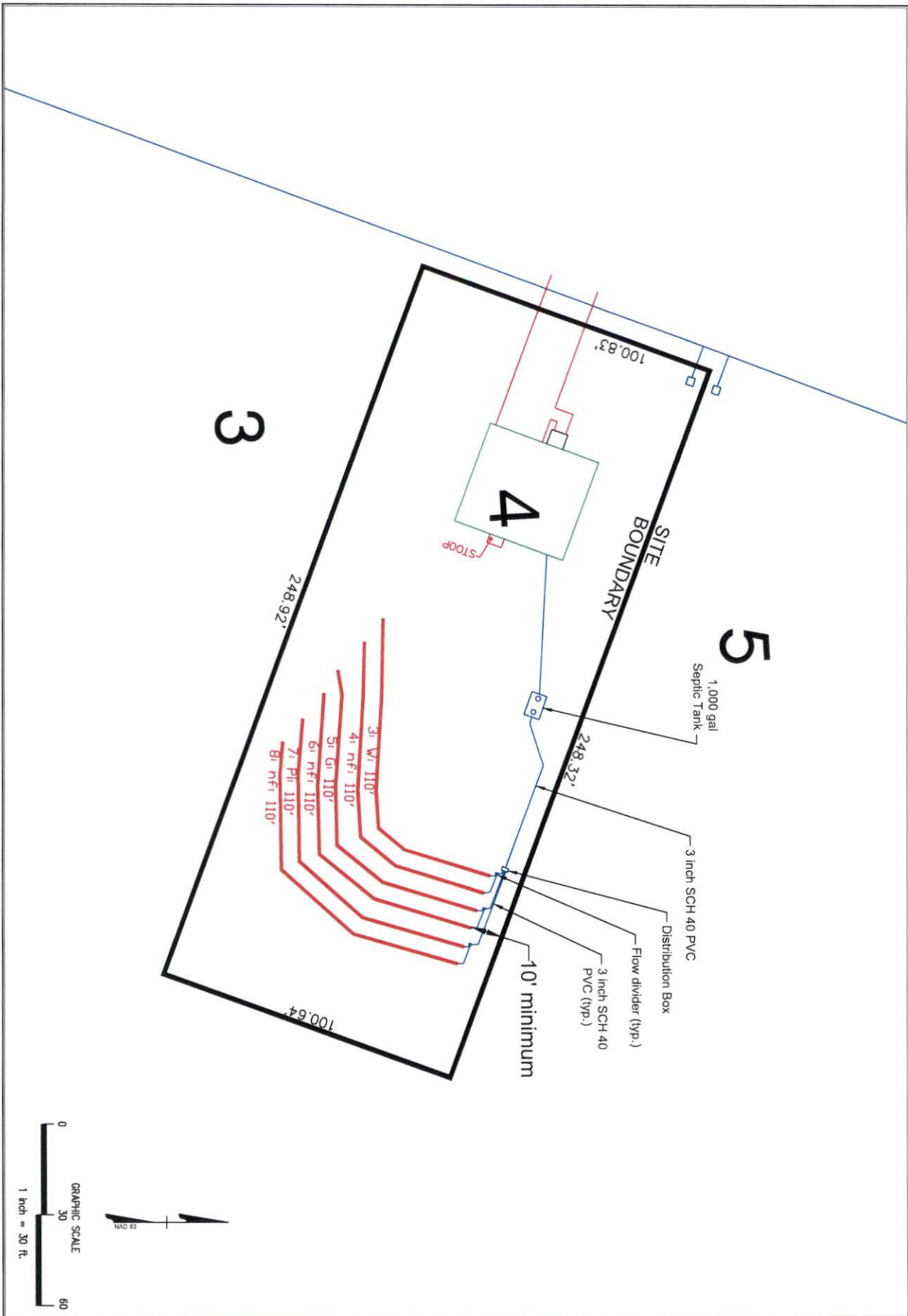



 <p>MITCHELL ENVIRONMENTAL, PA C-2917</p> <p>1501 LAKESTONE VILLAGE LANE SUITE 205 FUQUAY VARINA, NC 27526</p>	PREPARED FOR : HPHunt Homes of Raleigh 1401 Sunday Drive, Suite 109 Raleigh, NC 27607	REVISION NO. Original Submittal Revision 1 Revision 2 Revision 3 Master Set	DATE March 22, 2024 ----- ----- ----- -----	SHEET NUMBER 2 of 5 Holkes Pines Lot 4 Initial Nitrification Field
	DATE : March 22, 2024			
	DESIGNER CONTACT: ADAM AYCOCK, EI			
	DRAWN BY: ADAM AYCOCK, EI			

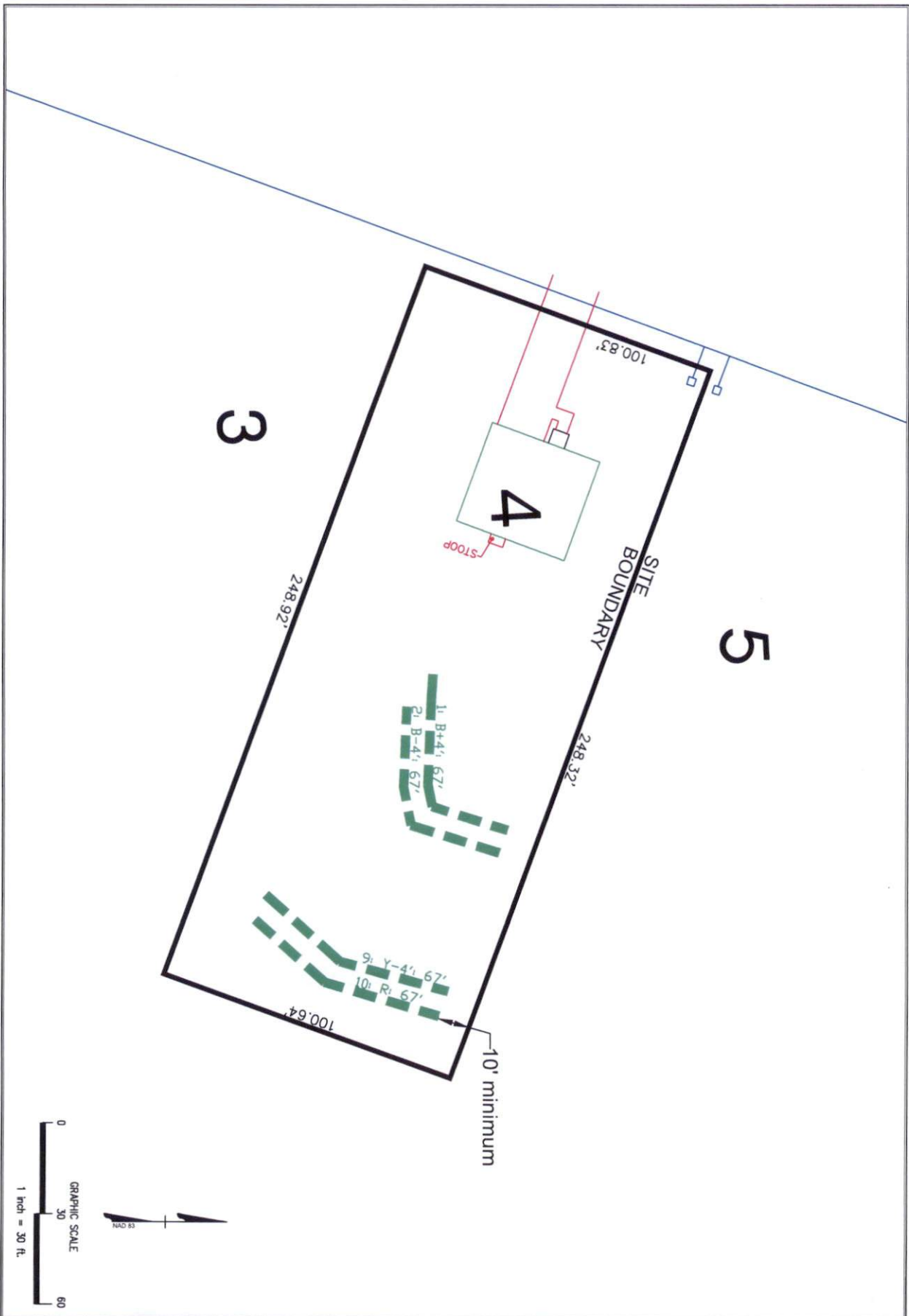

MITCHELL ENVIRONMENTAL, PA
 C-2911
 1501 LAKESTONE VILLAGE LANE
 SUITE 205
 FUQUAY VARINA, NC 27526

PREPARED FOR: H&H Homes of Raleigh
 1401 Sunday Drive, Suite 108
 Raleigh, NC 27607
 DATE: March 22, 2024
 DESIGNER CONTACT:
 ADAM AYCOCK, EI
 DRAWN BY:
 ADAM AYCOCK, EI

REVISION NO.	DATE
Original Submittal	March 22, 2024
Revision 1	-----
Revision 2	-----
Revision 3	-----
Master Set	-----

SHEET NUMBER
 3 of 5
 Holkes Pines
 Lot 4
 Repair Nitrification Field

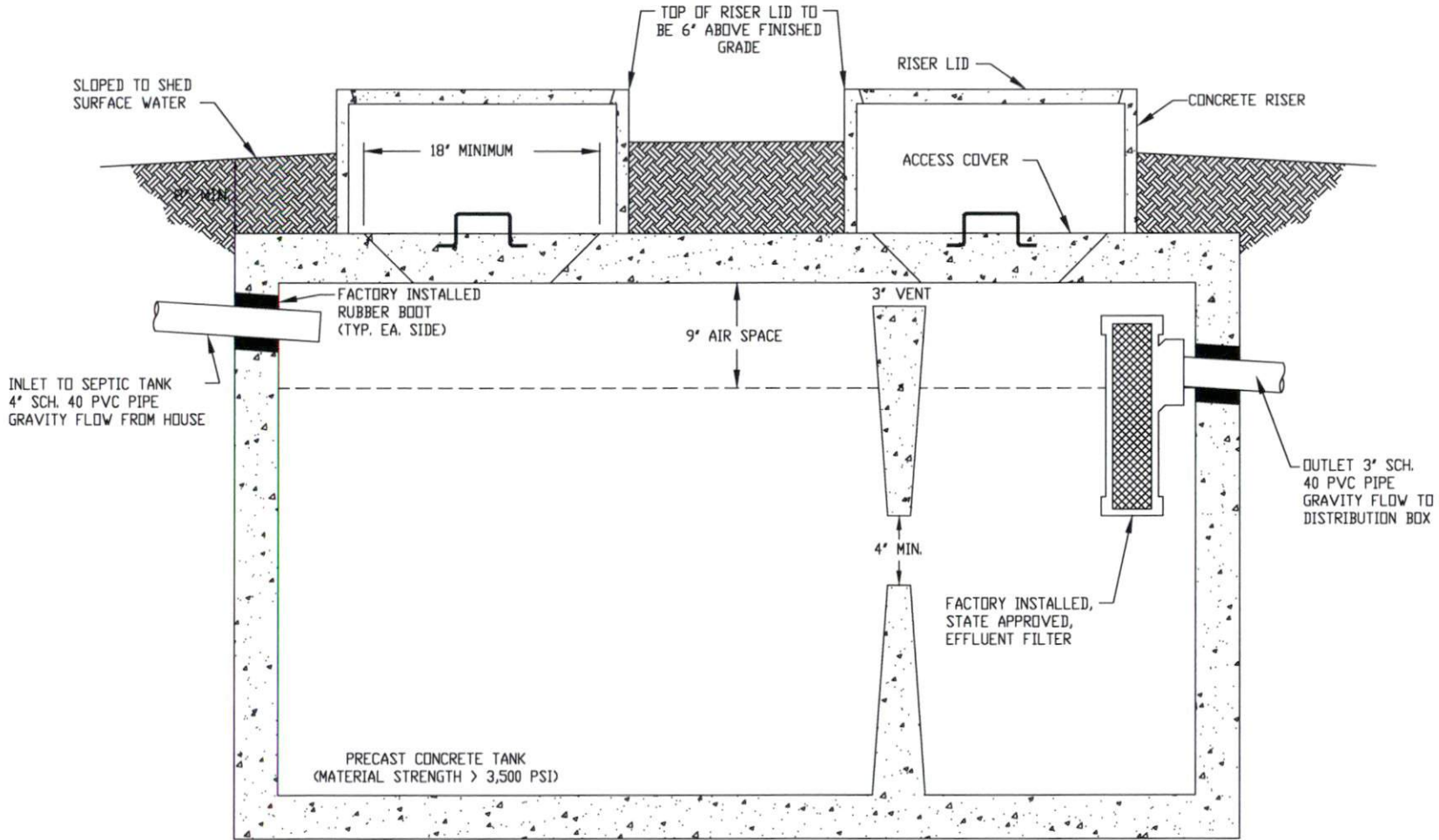

1,000 GALLON SEPTIC TANK

SEPTIC TANK DETAIL

N.T.S.

SHEET NUMBER	4 of 5
Rollies Pines Lot 4 Septic Tank Detail	

DATE	March 22, 2024
REVISION NO.	Original Submittal
	Revision 1
	Revision 2
	Revision 3
	Master Set
PREPARED FOR:	Warrent Homes of Raleigh 1401 Sandy Dine, Suite 108 Raleigh, NC 27607
DATE:	March 22, 2024
RESPONSE CONTACT:	ADAM WOOD, EI
DRAWN BY:	ADAM WOOD, EI

MITCHELL ENVIRONMENTAL, PA
C-2911
1501 LAKESTONE VILLAGE LANE
SUITE 205
FUQUAY VARINA, NC 27526

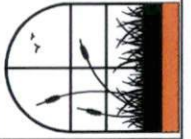

Trench Width = 12 Inches minimum
 Trench Depth = see Harnett County permit
 Trench Spacing = 6 Feet (Center-to-Center, Minimum)

CPP Gravelless LDP Trench Construction Details

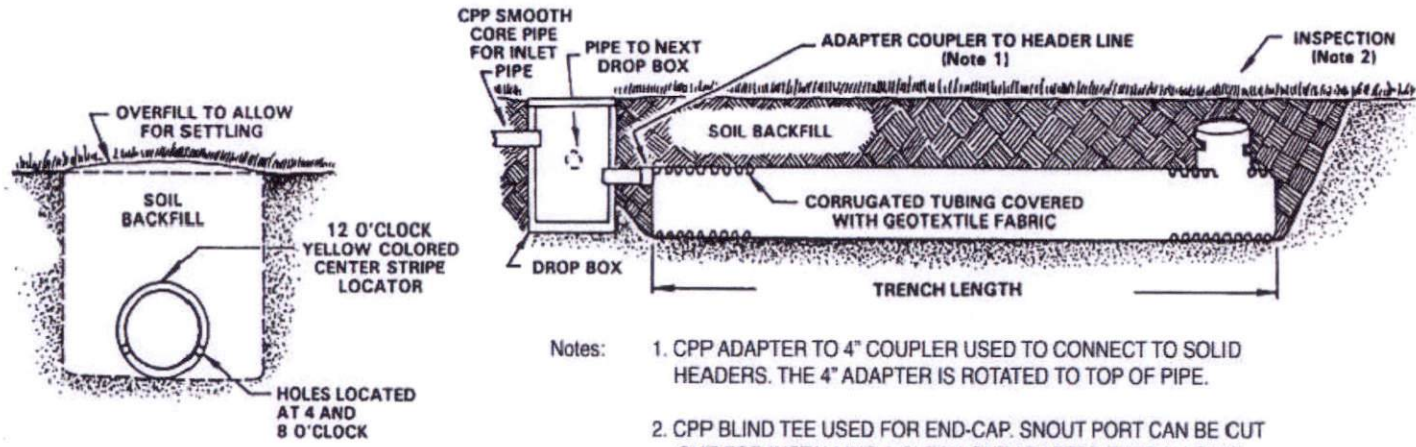

- Notes:
1. CPP ADAPTER TO 4" COUPLER USED TO CONNECT TO SOLID HEADERS. THE 4" ADAPTER IS ROTATED TO TOP OF PIPE.
 2. CPP BLIND TEE USED FOR END-CAP. SNOUT PORT CAN BE CUT OUT FOR INSTALLING A CLEAN OUT ADAPTER THAT ALLOWS FOR POST INSTALLATION INSPECTION.

MITCHELL ENVIRONMENTAL, PA C-2911 1501 LAKESTONE VILLAGE LANE SUITE 205 FUQUAY VARINA, NC 27526		PREPARED FOR : HARNETT COUNTY OF RALEIGH 1401 SANDY CREEK DRIVE RALEIGH, NC 27607	REVISION NO. Original Submit Revision 1 Revision 2 Revision 3 Motor Set	DATE March 22, 2024	SHEET NUMBER 5 of 5
		DATE: March 22, 2024 MANUFACTURER CONTACT: COUPLER PLASTIC PIPE DRAWN BY: COUPLER PLASTIC PIPE			
ROLLIES PAVAS Lot 4 Trench Detail					