

**FRONT ELEVATION 4**

SCALE: 1/8" = 1'-0"

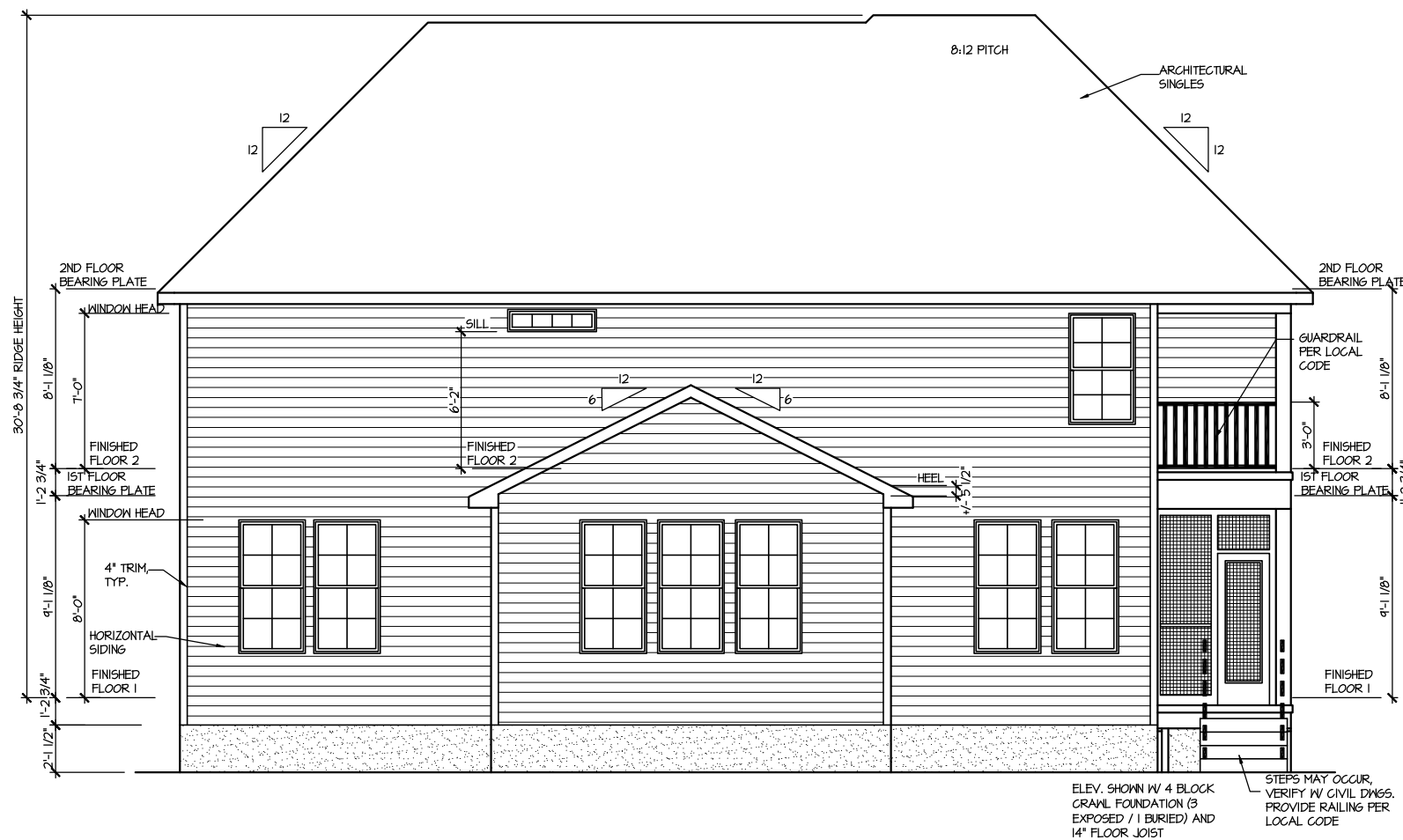

**REAR ELEVATION 4**

SCALE: 1/8" = 1'-0"

UPDATED DATE  
12-06-2021

MASTER PLAN INFORMATION  
REVISION DATE  
1-RALE 09-16-19

DRAWN BY:  
ITS

DATE:  
01/16/2024

PLAN NO.  
1635



HOUSE NAME:  
STONEFIELD  
DRAWING TITLE

FRONT & REAR ELEVATIONS

SHEET No.

A.I.

FILE: Lot\_00.0098 amendment.dwg DATE: 1/16/2024 10:50 AM

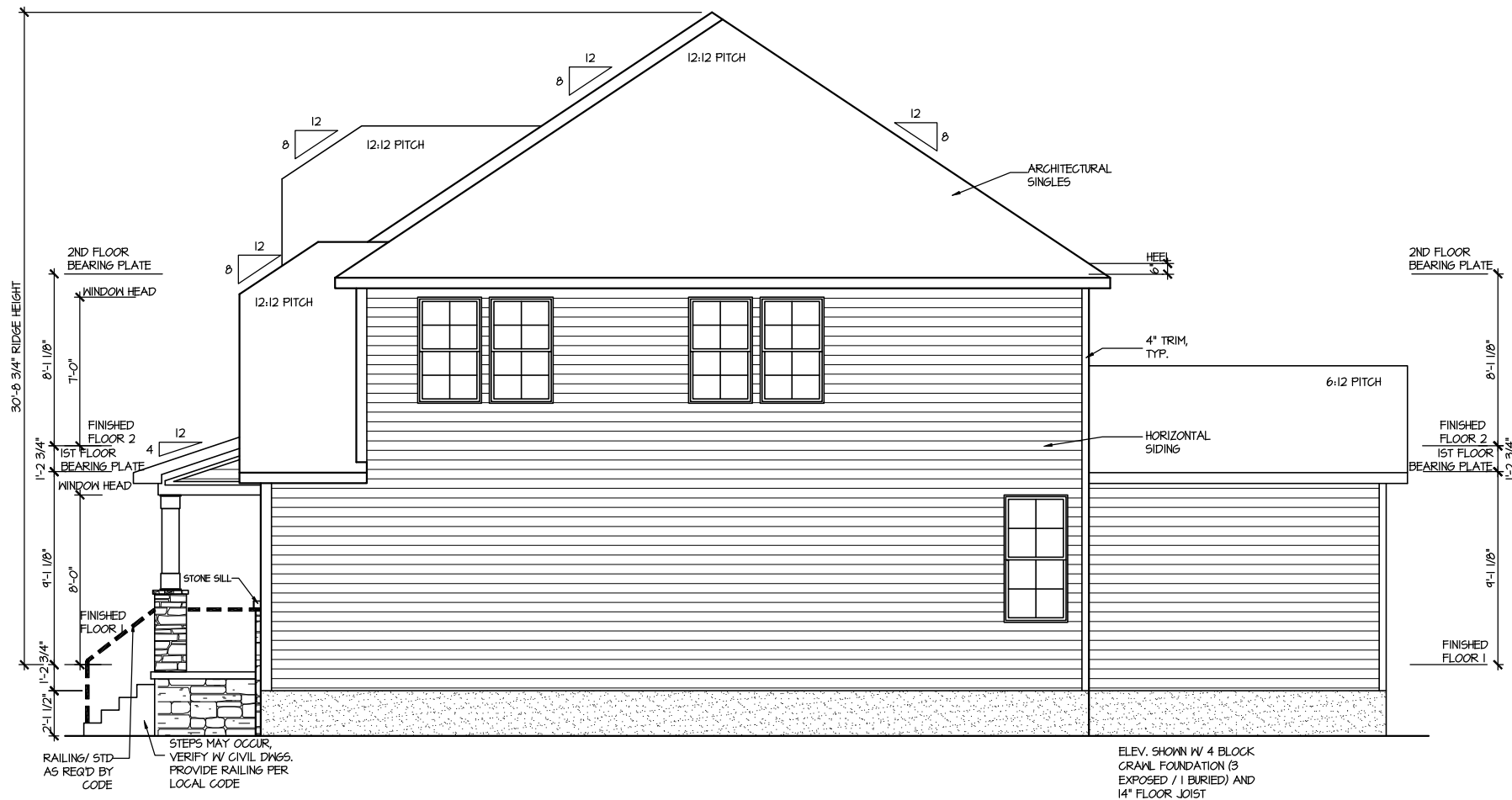

**RIGHT ELEVATION 4**

SCALE: 1/8" = 1'-0"

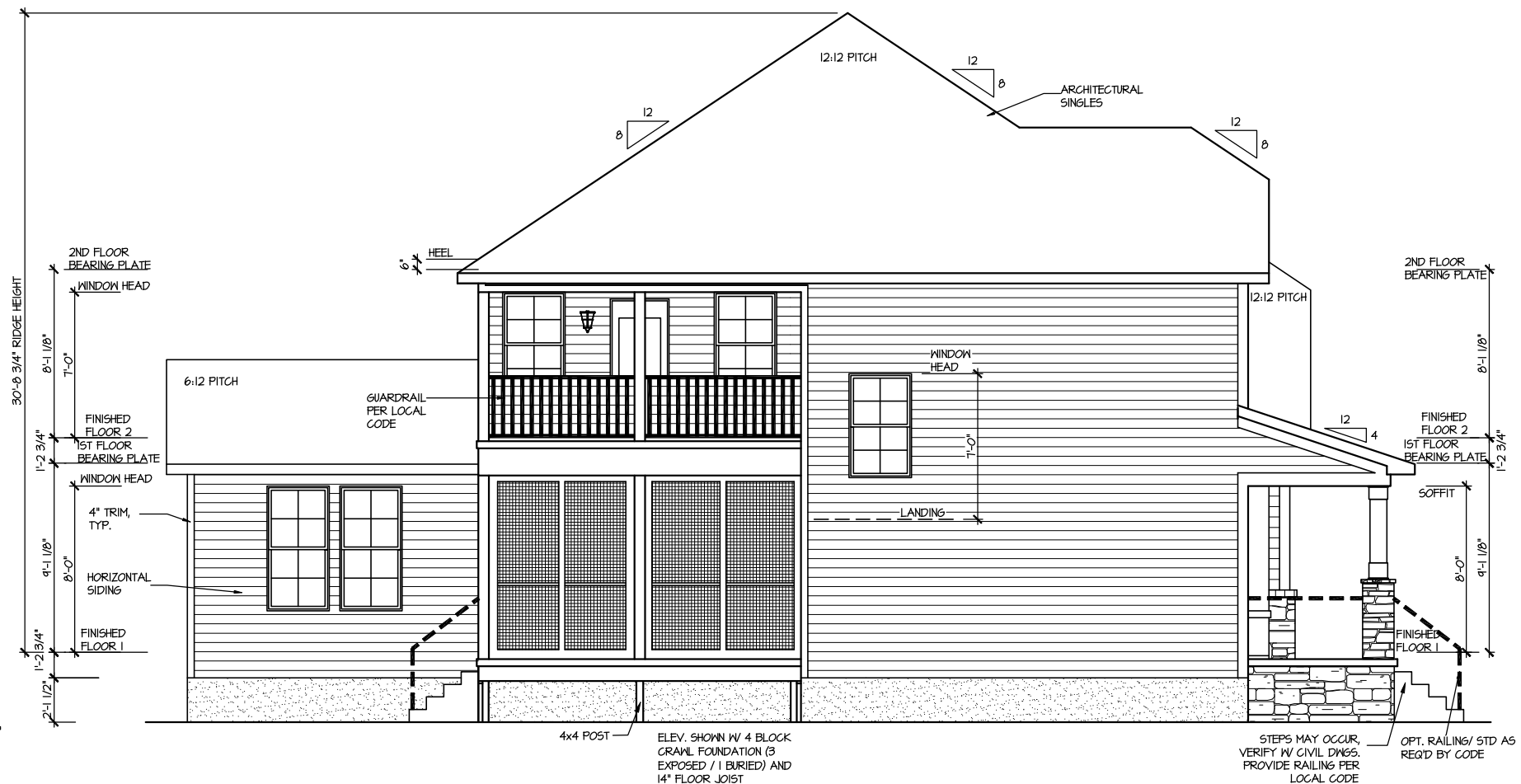

**LEFT ELEVATION 4**

SCALE: 1/8" = 1'-0"

MASTER PLAN INFORMATION	
REVISION	DATE
1 - SALE	09-16-19
UPDATED DATE: 12-06-2021	

DRAWN BY:	ITS
DATE:	01/16/2024
PLAN NO.	1635



HOUSE NAME:	STONEFIELD
DRAWING TITLE	RIGHT & LEFT ELEVATIONS

SHEET No.	A1.2
-----------	------

FILE: Lot\_00.0098 amendment.dwg DATE: 1/16/2024 10:50 AM

ATTIC VENT CALCULATION FOR PLAN '4'

**UPPER ROOF VENTILATION CALCULATIONS:**  
 ROOF AREA 1 = 1742 SQ. FT.  
**OVERALL REQUIRED VENTILATION:**  
 1 TO 150 = 11.65 SQ. FT.  
 1 TO 300 = 5.81 SQ. FT.  
 50% IN TOP THIRD = 2.91 SQ. FT. (1 TO 300)  
 NET FREE AREA OF VENTED SOFFIT = 5.1 SQ. IN / LINEAR FT.  
 NET FREE AREA OF RIDGE VENT = 10 SQ. IN / LINEAR FT.  
**LOWER VENTING (BOTTOM 2/3 RDS)**  
 20 LINEAR FEET OF SOFFIT X 5.1 SQ. IN = 3.245 SQ. FT.  
**UPPER VENTING (TOP 1/3 RDS)**  
 24 LINEAR FEET OF RIDGE X 10 SQ. IN = 3 SQ. FT.  
 3 SQ. FT. AT 50%  
 (1 TO 300 ALLOWED)

**UPPER ROOF VENTILATION CALCULATIONS:**  
 ROOF AREA 2 = 252 SQ. FT.  
**OVERALL REQUIRED VENTILATION:**  
 1 TO 150 = 1.60 SQ. FT.  
 1 TO 300 = 0.84 SQ. FT.  
 50% IN TOP THIRD = 0.42 SQ. FT. (1 TO 300)  
 NET FREE AREA OF VENTED SOFFIT = 5.1 SQ. IN / LINEAR FT.  
 NET FREE AREA OF RIDGE VENT = 10 SQ. IN / LINEAR FT.  
**LOWER VENTING (BOTTOM 2/3 RDS)**  
 11 LINEAR FEET OF SOFFIT X 5.1 SQ. IN = 0.435 SQ. FT.  
**UPPER VENTING (TOP 1/3 RDS)**  
 4 LINEAR FEET OF RIDGE X 10 SQ. IN = 0.5 SQ. FT.  
 0.5 SQ. FT. AT 50%  
 (1 TO 300 ALLOWED)

**UPPER ROOF VENTILATION CALCULATIONS:**  
 ROOF AREA 3 = 84 SQ. FT.  
**OVERALL REQUIRED VENTILATION:**  
 1 TO 150 = 5.45 SQ. FT.  
 1 TO 300 = 2.71 SQ. FT.  
 50% IN TOP THIRD = 1.40 SQ. FT. (1 TO 300)  
 NET FREE AREA OF VENTED SOFFIT = 5.1 SQ. IN / LINEAR FT.  
 NET FREE AREA OF RIDGE VENT = 10 SQ. IN / LINEAR FT.  
**LOWER VENTING (BOTTOM 2/3 RDS)**  
 23 LINEAR FEET OF SOFFIT X 5.1 SQ. IN = 0.91 SQ. FT.  
**UPPER VENTING (TOP 1/3 RDS)**  
 8 LINEAR FEET OF RIDGE X 10 SQ. IN = 1 SQ. FT.  
 1 SQ. FT. BETWEEN 50%  
 (1 TO 300 ALLOWED)

**UPPER ROOF VENTILATION CALCULATIONS:**  
 ROOF AREA 4 = 142 SQ. FT.  
**OVERALL REQUIRED VENTILATION:**  
 1 TO 150 = 0.947 SQ. FT.  
 1 TO 300 = 0.473 SQ. FT.  
 50% IN TOP THIRD = 0.237 SQ. FT. (1 TO 300)  
 NET FREE AREA OF VENTED SOFFIT = 5.1 SQ. IN / LINEAR FT.  
 NET FREE AREA OF RIDGE VENT = 10 SQ. IN / LINEAR FT.  
**LOWER VENTING (BOTTOM 2/3 RDS)**  
 20 LINEAR FEET OF SOFFIT X 5.1 SQ. IN = 0.71 SQ. FT.  
**UPPER VENTING (TOP 1/3 RDS)**  
 8 LINEAR FEET OF RIDGE X 10 SQ. IN = 1 SQ. FT.  
 1 SQ. FT. AT 50%  
 (1 TO 300 ALLOWED)

NOTE: ROOF PLANS SHOWN W/ MIN. REQ'D RIDGE VENT LOCATIONS.  
 ACTUAL RIDGE VENT LOCATIONS AND QUANTITY PER BUILDER

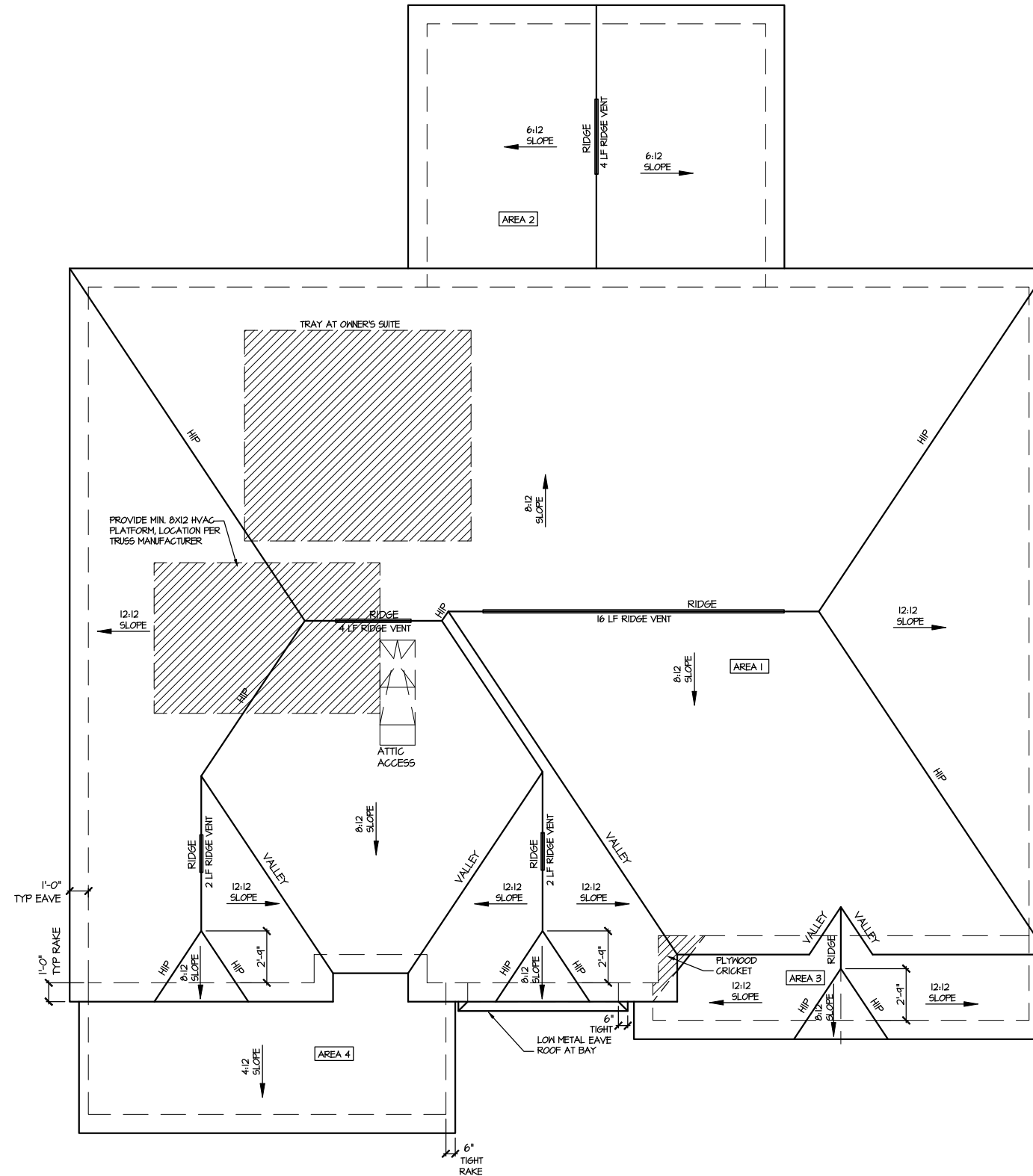

**ROOF PLAN ELEV. 4**

SCALE: 1/8" = 1'-0"

MASTER PLAN INFORMATION	
REVISION	DATE
1-RALE	09-16-19
UPDATED DATE	12-06-2021

DRAWN BY: ITS  
 DATE: 01/16/2024  
 PLAN NO. 1635



HOUSE NAME: STONEFIELD  
 DRAWING TITLE: ROOF PLAN

SHEET No. A13



CRAWL SPACE VENT CALCULATIONS: ELEV 4  
 CRAWL AREA = 1552 SQ. FT.  
 OVERALL REQUIRED VENTILATION:  
 1 SQ. IN. PER 1 SQ. FT. = 1552 SQ. IN.

NET FREE AREA OF VENT = 72 SQ. IN. PER VENT  
 WITHIN AUTOMATIC VENT OAL-1 OR EQUAL

VENTING REQUIREMENT:  
 1552 SQ. IN. / 72 SQ. IN. = 21.6 VENTS = 22 VENTS

ONLY VENTS ON THE FRONT ELEVATION ARE SHOWN.  
 ALL OTHERS TO BE FIELD LOCATED.  
 VENTS SHALL BE INSTALLED PER R322.2.2 - R322.2.2.1

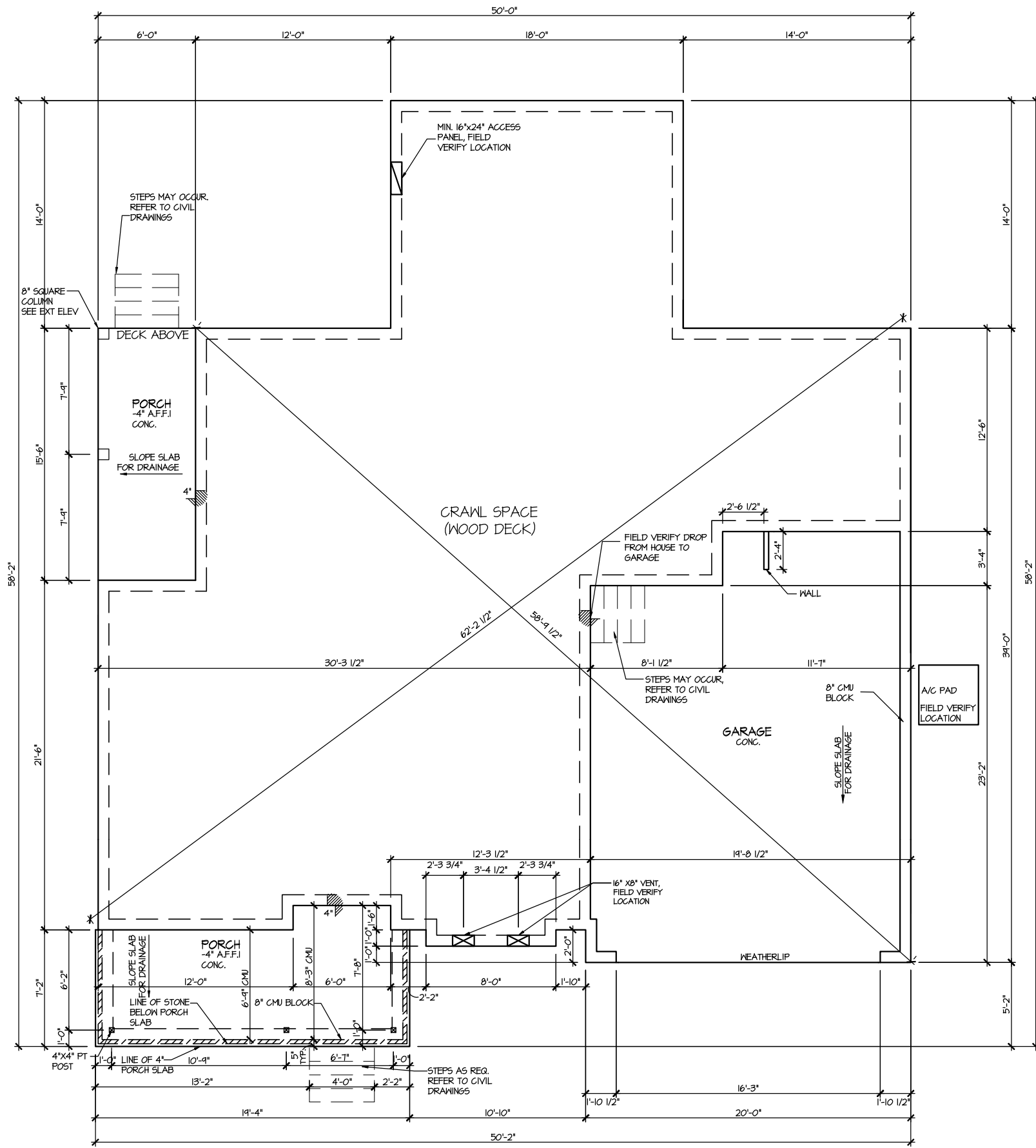

ELEVATION 4  
 CRAWL SPACE PLAN  
 SCALE: 1/8" = 1'-0"

MASTER PLAN INFORMATION	
REVISION	DATE
1 - RALE	09-16-19
	UPDATED DATE
	12-06-2021

DRAWN BY:  
 ITS  
 DATE:  
 01/16/2024  
 PLAN NO.  
 1635



HOUSE NAME:  
 STONEFIELD  
 DRAWING TITLE  
 CRAWL SPACE PLAN

SHEET No.  
 A2.1

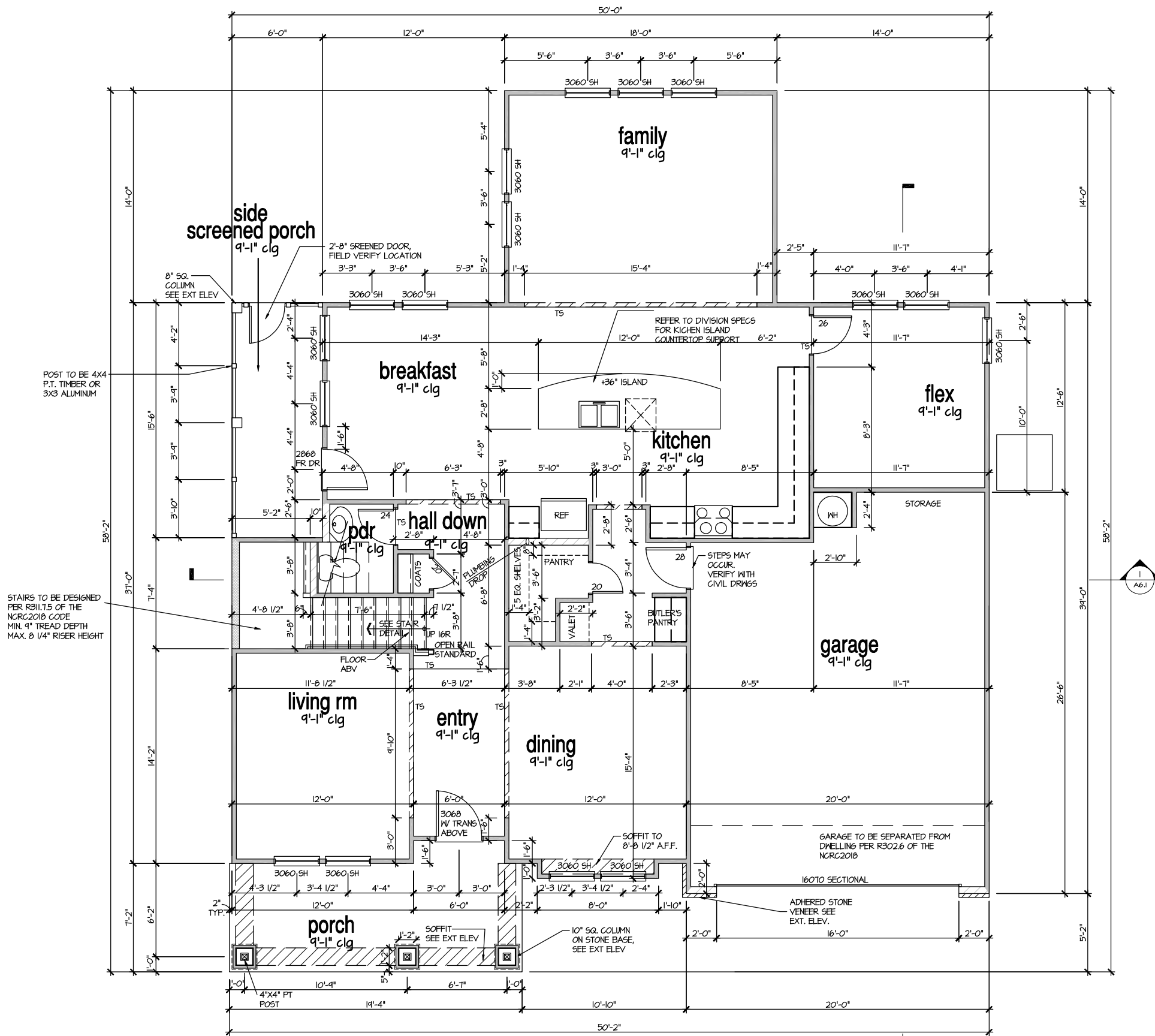

ELEVATION 4  
FIRST FLOOR PLAN  
SCALE: 1/8" = 1'-0"

MASTER PLAN INFORMATION	
REVISION	DATE
1 - RALE	09-16-19
UPDATED DATE	12-06-2021

DRAWN BY:	ITS
DATE:	01/16/2024
PLAN NO.	1635



HOUSE NAME:	STONEFIELD
DRAWING TITLE	FIRST FLOOR PLAN

SHEET No.	A3.1
-----------	------

FILE: Lot 00.0098 amendment.dwg DATE: 1/16/2024 10:50 AM

FILE: Lot\_00.0098 amendment.dwg DATE: 1/16/2024 10:50 AM

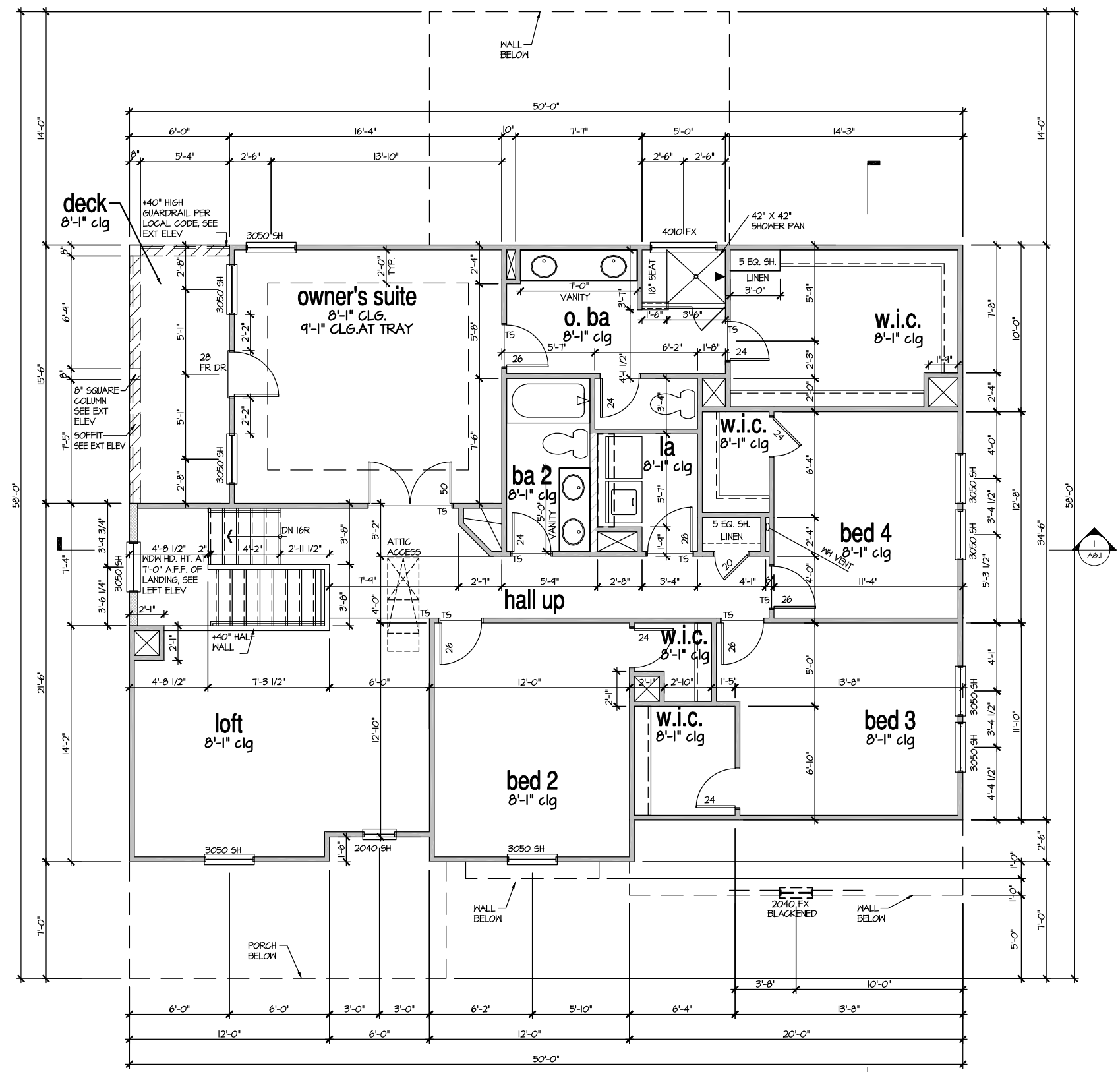

ELEVATION 4  
 SECOND FLOOR PLAN  
 SCALE: 1/8" = 1'-0"

MASTER PLAN INFORMATION	
REVISION	DATE
1 - RALE	09-16-19
UPDATED DATE	12-06-2021

DRAWN BY: ITS	
DATE: 01/16/2024	
PLAN NO. 1635	



HOUSE NAME:	STONEFIELD
DRAWING TITLE	SECOND FLOOR PLAN

SHEET No.  
 A3.2

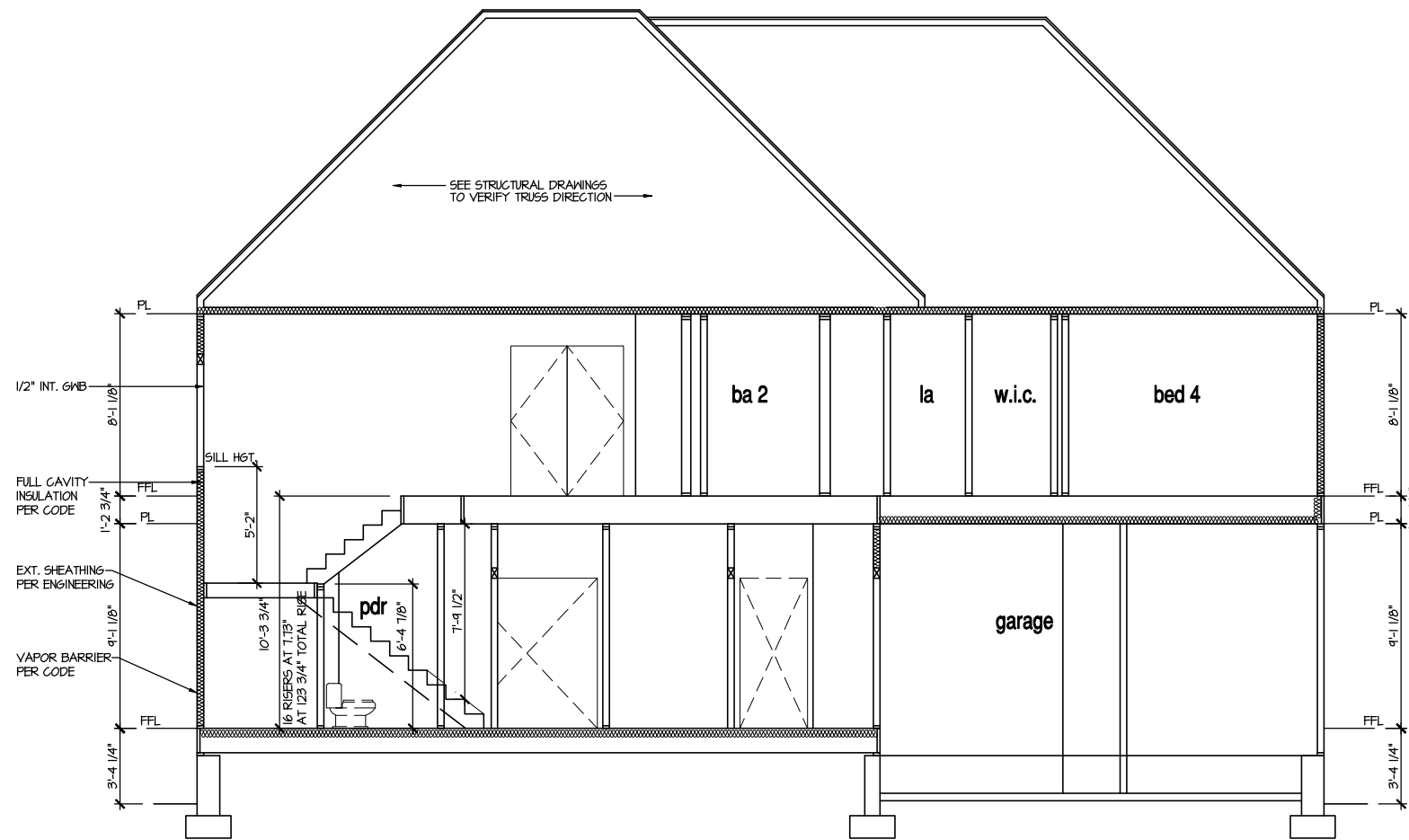

**SECTION 1**

SCALE: 1/8" = 1'-0"

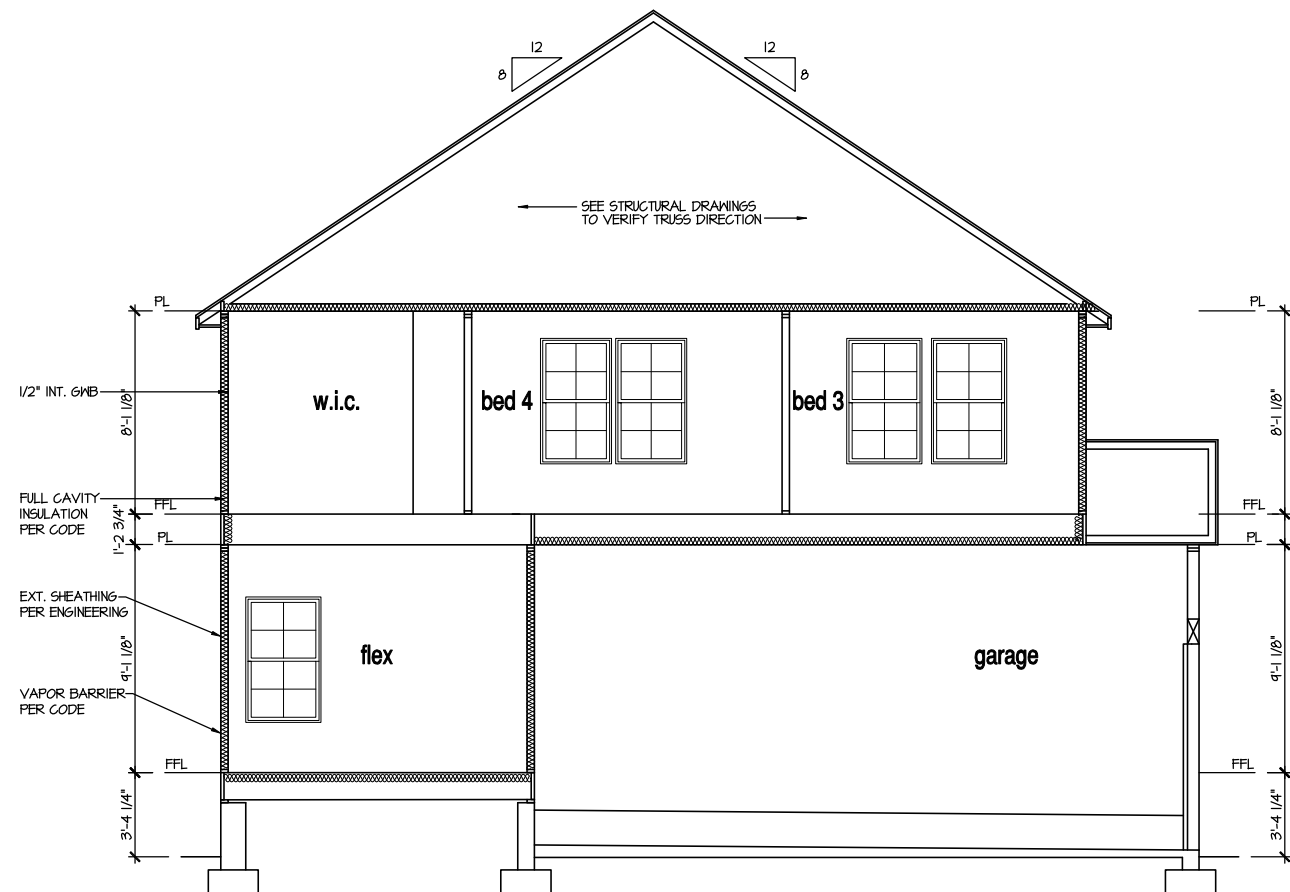

**SECTION 2**

SCALE: 1/8" = 1'-0"

**9'-1" STAIR NOTE:**  
 (USE 14" TJI WITH 3/4" PLYWOOD SUBFLOOR)  
 15 TREADS AT 10" EACH VERIFY  
 16 RISERS AT +/- 1.73" = 123 3/4" TOTAL  
 RISE VERIFY

**NOTES:**

- BUILDING SECTIONS SHOWN HERE DEPICT VOLUME SPACES WITHIN THE STRUCTURE. REFER TO STRUCTURAL DRAWINGS, TRUSS DRAWINGS, STRUCTURAL DETAILS AND CALCULATIONS BY OTHER FOR ALL STRUCTURAL INFO.
- ROOFING: PITCHED SHINGLE ROOF. REFER TO ROOF PLAN FOR TYPICALS.
- WOOD FLOORS: FLOOR SHEATHING OVER FLOOR JOIST. REFER TO STRUCTURAL AND TRUSS DRAWINGS BY OTHERS.
- INSULATION:
 

EXTERIOR WALLS:	R-15 BATTLS MINIMUM. VERIFY
CEILING WITH ATTIC ABOVE:	R-30 BATTLS MINIMUM. VERIFY
FLOOR OVER GARAGE:	R-14 BATTLS MINIMUM. VERIFY
ATTIC KNEEWALL:	R-14 BATTLS MINIMUM. VERIFY

PER STATE RESIDENTIAL CODE  
 COMPLIANCE METHOD TO BE  
 DETERMINED BY BUILDER.

MASTER PLAN INFORMATION	
REVISION	DATE
1-RALE	09-16-19
UPDATED DATE	12-06-2021

DRAWN BY:	ITS
DATE:	01/16/2024
PLAN NO.	1635

**DRB HOMES**

HOUSE NAME:  
**STONEFIELD**  
 DRAWING TITLE:  
**BUILDING SECTION**

SHEET No.  
**A4.1**

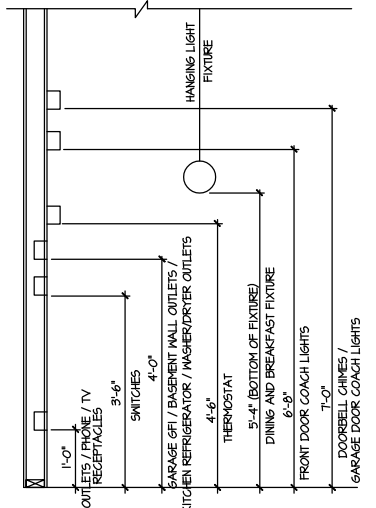

STANDARD ELECTRICAL BOX HEIGHTS

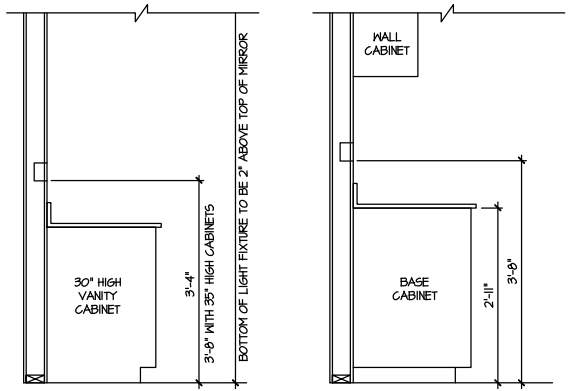

SWITCH AND RECEPTACLE BOXES OVER BATH CABINETS  
SWITCH AND RECEPTACLE BOXES OVER KITCHEN CABINETS

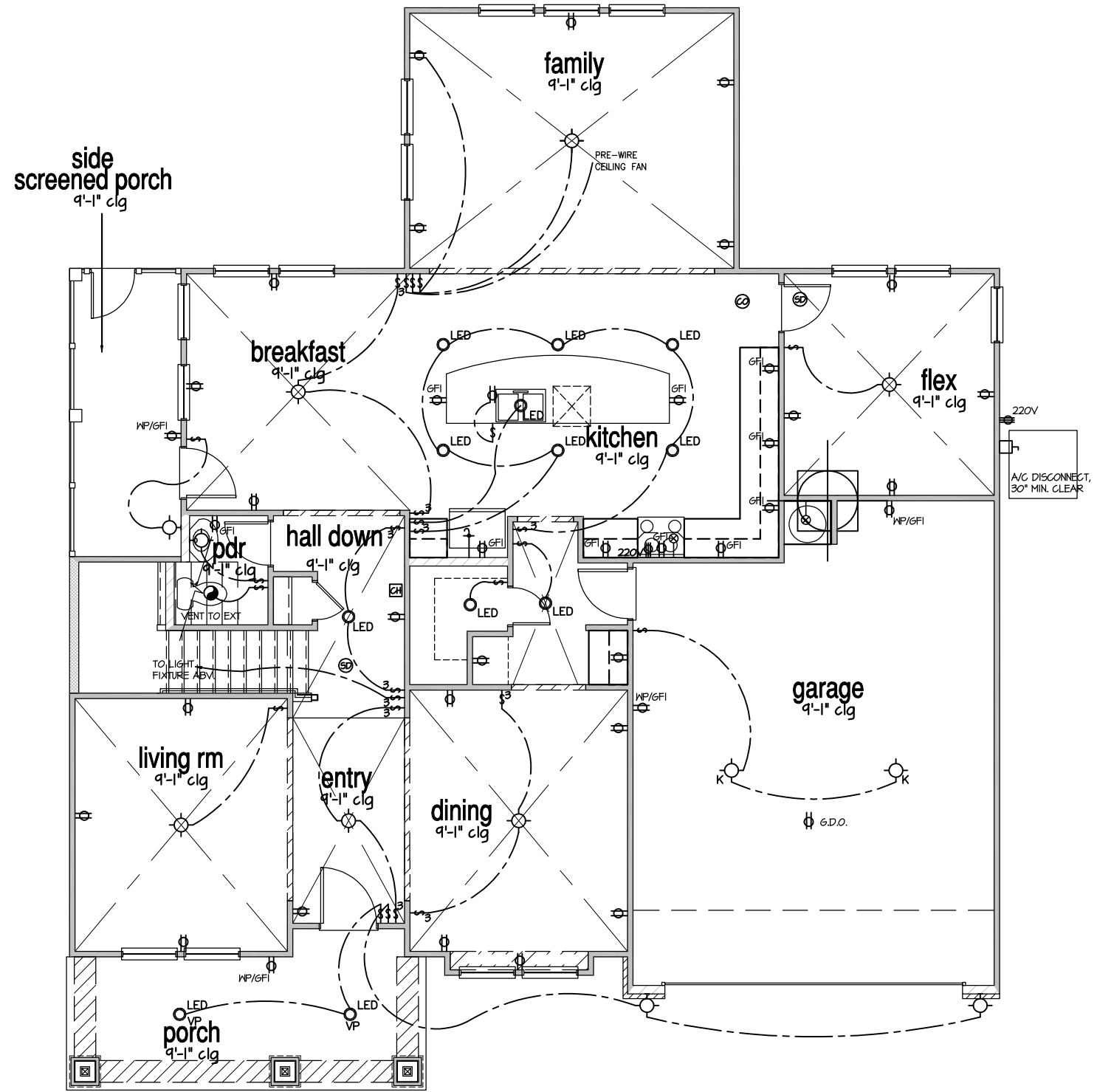

**NOTES:**

- PROVIDE AND INSTALL LOCALLY CERTIFIED SMOKE DETECTORS AND CO2 DETECTORS AS REQUIRED BY NATIONAL FIRE PROTECTION ASSOCIATION (NFPA) AND MEETING THE REQUIREMENTS OF ALL GOVERNING CODES.
- PROVIDE AND INSTALL GROUND FAULT CIRCUIT-INTERRUPTERS (GFI) AS REQUIRED BY NATIONAL ELECTRICAL CODE (NEC) AND MEETING THE REQUIREMENTS OF ALL GOVERNING CODES.
- ELECTRICAL CONTRACTOR TO PROVIDE REQUIRED DIRECT HOOK-UPS/CUTOFFS.
- HVAC CONTRACTOR TO VERIFY THERMOSTAT LOCATIONS.
- ALL ELECTRICAL AND MECHANICAL EQUIPMENT (FURNACES, A/C UNITS, ELECTRICAL PANELS, SANITARY SUMP PITS, DRAIN TILE SUMP, AND WATER HEATERS) ARE SUBJECT TO RELOCATION DUE TO FIELD CONDITIONS.
- PROVIDE POWER, LIGHT AND SWITCH AS REQUIRED FOR ATTIC FURNACE PER CODE AND MANUFACTURER'S WRITTEN INSTRUCTIONS.
- CLOSET LIGHTS TO BE FLOURESCENT FIXTURES FOR INC & INCANDESCENT CLG. MOUNTED FIXTURES FOR ALL OTHER AREAS.

**LEGEND:**

⊕	AFGI DUPLEX OUTLET	⊙	CEILING MOUNTED INCANDESCENT LIGHT FIXTURE	☒	CHIMES	⊗	CEILING FAN (PROVIDE ADEQUATE SUPPORT)
⊕ WP/GFI	WEATHERPROOF GFI AFGI DUPLEX OUTLET	⊙ K	KEYLESS LIGHT	⊕	PUSHBUTTON SWITCH	⊗	CEILING FAN WITH INCANDESCENT LIGHT FIXTURE (PROVIDE ADEQUATE SUPPORT)
⊕ GFI	GROUND-FAULT CIRCUIT-INTERRUPTER AFGI DUPLEX OUTLET	⊙	MALL MOUNTED INCANDESCENT LIGHT FIXTURE	⊕	110V SMOKE DETECTOR W/ BATTERY BACKUP	⊗	CEILING FAN WITH INCANDESCENT LIGHT FIXTURE (PROVIDE ADEQUATE SUPPORT)
⊕	HALF-SWITCHED AFGI DUPLEX OUTLET	⊙	RECESSED LIGHT FIXTURE	⊕	CO2 DETECTOR	⊕	GAS SUPPLY WITH VALVE
⊕ 220V	220 VOLT AFGI OUTLET	⊙ LED	LED SURFACE MOUNTED	⊕	THERMOSTAT	⊕	HOSE BIBB
⊕	REINFORCED JUNCTION BOX	⊕	EXHAUST FAN (VENT TO EXTERIOR)	☒	TELEPHONE	⊕	1/4" WATER STUB OUT
⊕	WALL SWITCH	⊕	EXHAUST FAN/LIGHT COMBINATION (VENT TO EXTERIOR)	☒	TELEVISION	⊕	
⊕ 3	THREE-WAY SWITCH	⊕	TECH. HUB SYSTEM	☒	ELECTRIC METER		
⊕ 4	FOUR-WAY SWITCH			☒	ELECTRIC PANEL		
⊕	LED STRIP FIXTURE			☒	DISCONNECT SWITCH		

ELECTRICAL PLAN  
FIRST FLOOR - ELEV. 4  
SCALE: 1/8" = 1'-0"

**MASTER PLAN INFORMATION**

REVISION	DATE	UPDATED DATE
1 - RALE	09-16-19	12-06-2021

DRAWN BY: ITS  
DATE: 01/16/2024  
PLAN NO. 1635



HOUSE NAME: STONEFIELD  
DRAWING TITLE: FIRST FLOOR ELECTRICAL

SHEET No. E.I.

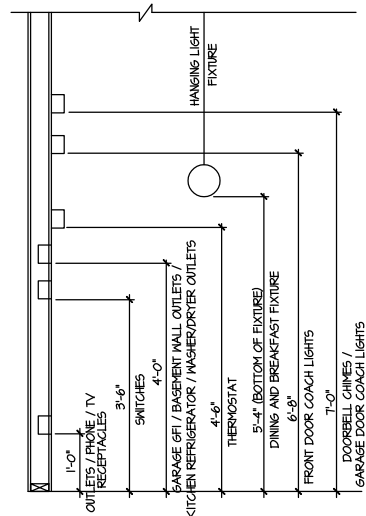

STANDARD ELECTRICAL BOX HEIGHTS

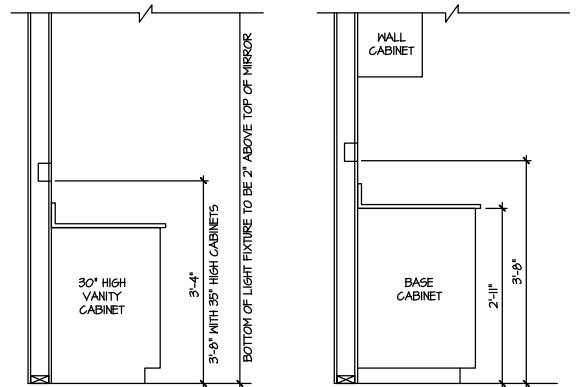

SWITCH AND RECEPTACLE BOXES OVER BATH CABINETS  
SWITCH AND RECEPTACLE BOXES OVER KITCHEN CABINETS

deck  
8'-1" clg

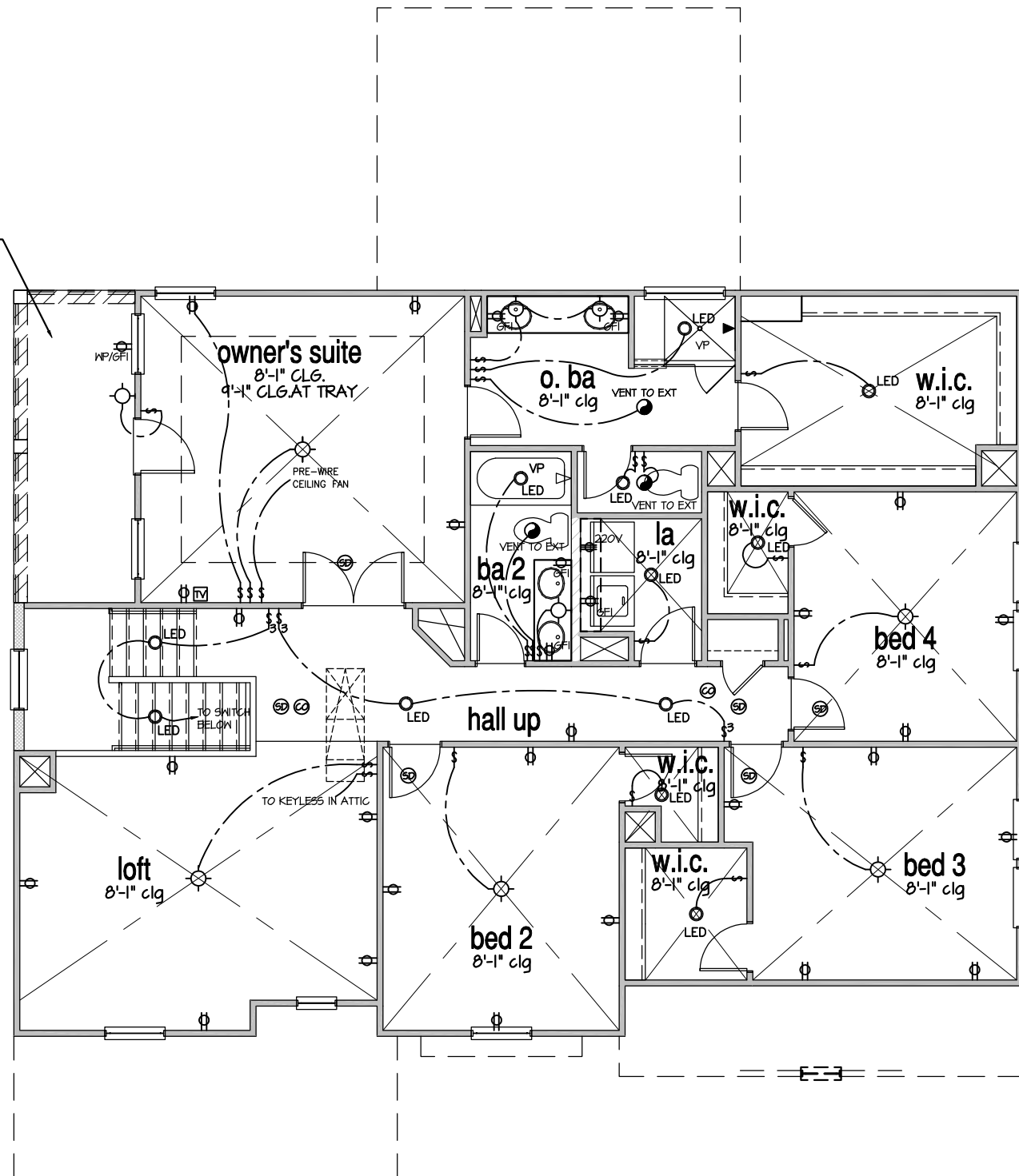

**NOTES:**

- PROVIDE AND INSTALL LOCALLY CERTIFIED SMOKE DETECTORS AND CO2 DETECTORS AS REQUIRED BY NATIONAL FIRE PROTECTION ASSOCIATION (NFPA) AND MEETING THE REQUIREMENTS OF ALL GOVERNING CODES.
- PROVIDE AND INSTALL GROUND FAULT CIRCUIT-INTERRUPTERS (GFI) AS REQUIRED BY NATIONAL ELECTRICAL CODE (NEC) AND MEETING THE REQUIREMENTS OF ALL GOVERNING CODES.
- ELECTRICAL CONTRACTOR TO PROVIDE REQUIRED DIRECT HOOK-UPS/CUTOFFS.
- HVAC CONTRACTOR TO VERIFY THERMOSTAT LOCATIONS.
- ALL ELECTRICAL AND MECHANICAL EQUIPMENT (FURNACES, A/C UNITS, ELECTRICAL PANELS, SANITARY SUMP PITS, DRAIN TILE PUMP, AND WATER HEATERS) ARE SUBJECT TO RELOCATION DUE TO FIELD CONDITIONS.
- PROVIDE POWER, LIGHT AND SWITCH AS REQUIRED FOR ATTIC FURNACE PER CODE AND MANUFACTURER'S WRITTEN INSTRUCTIONS.
- CLOSET LIGHTS TO BE FLOURESCENT FIXTURES FOR NC & INCANDESCENT CLG. MOUNTED FIXTURES FOR ALL OTHER AREAS.

**LEGEND:**

⊕	AFGI DUPLEX OUTLET	☉	CEILING MOUNTED INCANDESCENT LIGHT FIXTURE	☒	CHIMES	☒	CEILING FAN (PROVIDE ADEQUATE SUPPORT)
⊕NFPA/GFI	WEATHERPROOF GFI AFGI DUPLEX OUTLET	☼	KEYLESS LIGHT	⊞	PUSHBUTTON SWITCH	☒	CEILING FAN WITH INCANDESCENT LIGHT FIXTURE (PROVIDE ADEQUATE SUPPORT)
⊕GFI	GROUND-FAULT CIRCUIT-INTERRUPTER AFGI DUPLEX OUTLET	☉	WALL MOUNTED INCANDESCENT LIGHT FIXTURE	⊞	110V SMOKE DETECTOR W/ BATTERY BACKUP	☒	CEILING FAN WITH INCANDESCENT LIGHT FIXTURE (PROVIDE ADEQUATE SUPPORT)
⊕	HALF-SWITCHED AFGI DUPLEX OUTLET	☼	RECESSED LIGHT FIXTURE	⊞	CO2 DETECTOR	☒	GAS SUPPLY WITH VALVE
⊕220V	220 VOLT AFGI OUTLET	☉LED	LED SURFACE MOUNTED	⊞	THERMOSTAT	☒	HOSE BIBB
⊕	REINFORCED JUNCTION BOX	☉	EXHAUST FAN (VENT TO EXTERIOR)	☒	TELEPHONE	☒	1/4" WATER STUB OUT
⊕	WALL SWITCH	☉	EXHAUST FAN/LIGHT COMBINATION (VENT TO EXTERIOR)	☒	TELEVISION	☒	TECH. HUB SYSTEM
⊕3	THREE-WAY SWITCH	☉	LED STRIP FIXTURE	☒	ELECTRIC METER	☒	
⊕4	FOUR-WAY SWITCH	☉		☒	ELECTRIC PANEL	☒	
☒	LED STRIP FIXTURE	☉		☒	DISCONNECT SWITCH	☒	

ELECTRICAL PLAN  
SECOND FLOOR - ELEV. 4  
SCALE: 1/8" = 1'-0"

MASTER PLAN INFORMATION

REVISION	DATE	UPDATED DATE
1 - RALE	09-16-19	12-06-2021

DRAWN BY: ITS  
DATE: 01/16/2024  
PLAN NO. 1635

**DRB HOMES**

HOUSE NAME: STONEFIELD  
DRAWING TITLE: SECOND FLOOR ELECTRICAL

SHEET No. E1.2

FILE: Lot\_00.0098 amendment.dwg DATE: 1/16/2024 10:50 AM

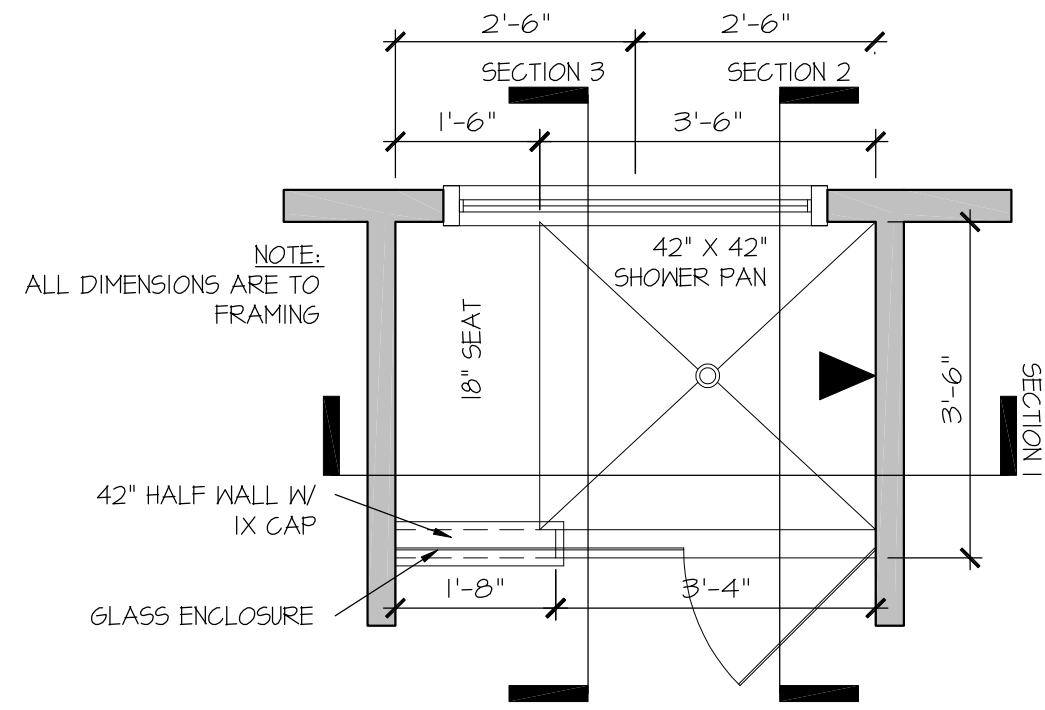

RALE TILE SHOWER  
42" X 42" W 18" SEAT  
SCALE: 1/2" = 1'-0"

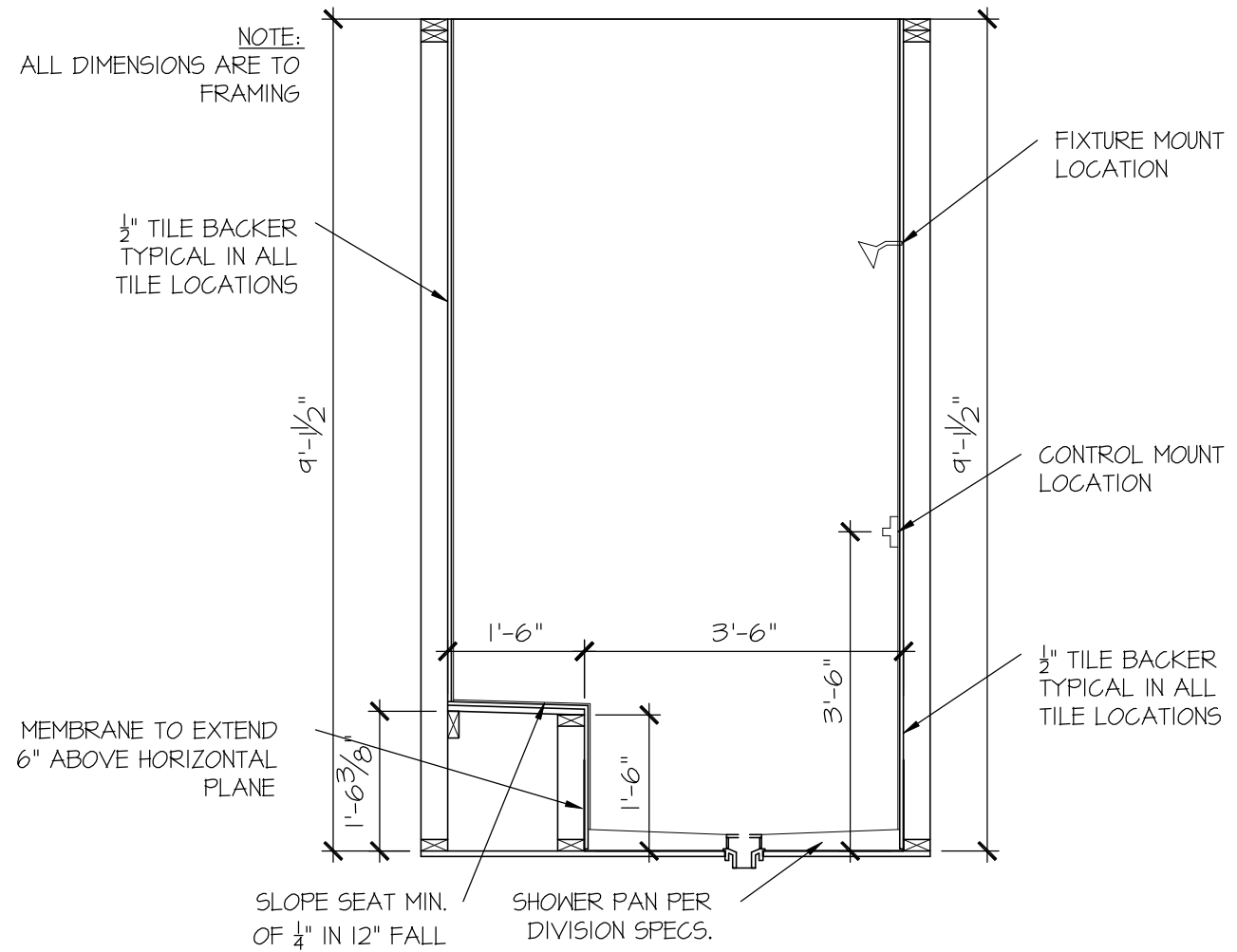

RALE TILE SHOWER  
SECTION A  
SCALE: 1/2" = 1'-0"



DRAWN BY:  
L. BEAVERS  
DATE: 9/1/22  
PLAN NO.  
11 X 17 SCALE  
24 X 36 SCALE

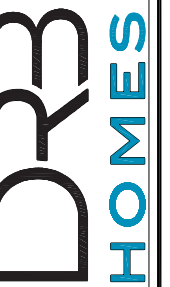

HOUSE NAME:  
DRAWING TITLE  
RALE TILE SHOWER DETAIL

SHEET No.  
01.12

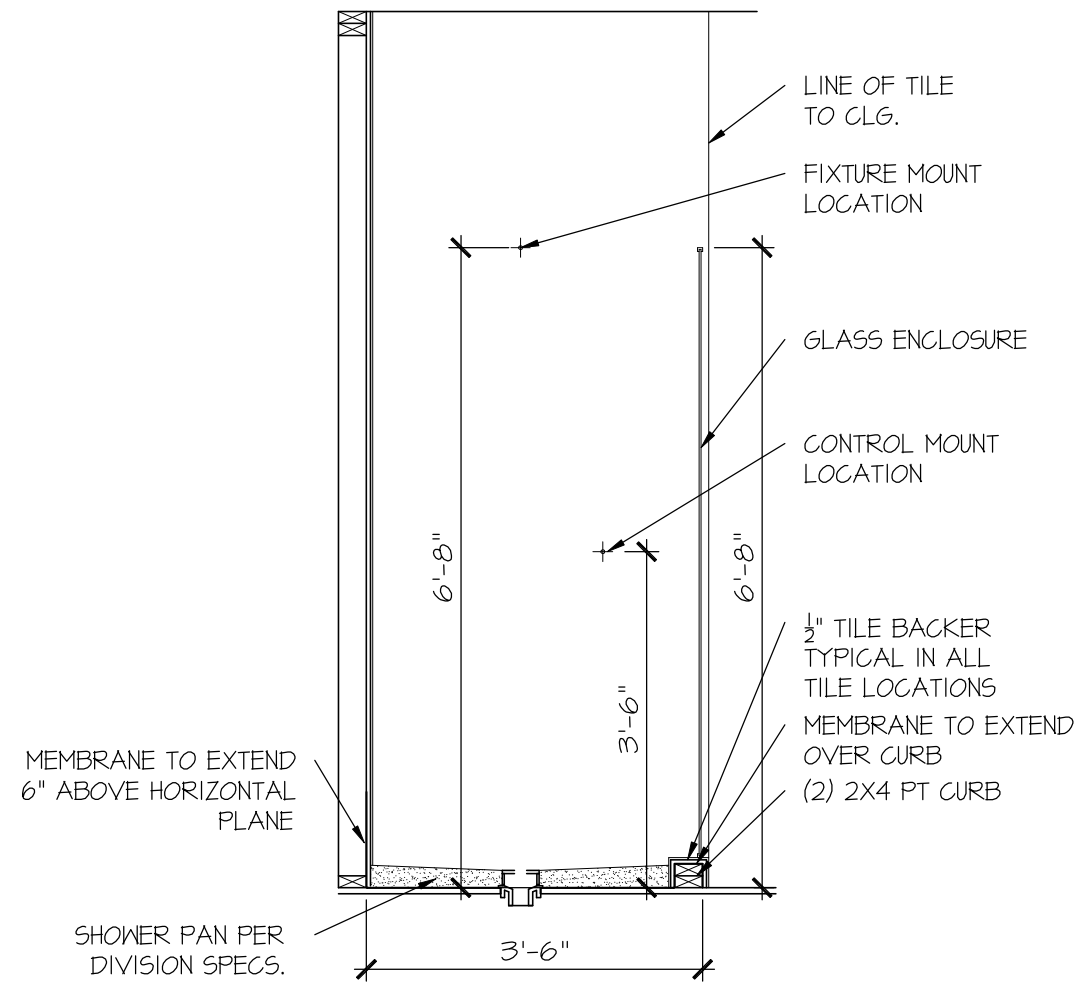

RALE TILE SHOWER  
SECTION B  
SCALE: 1/2" = 1'-0"

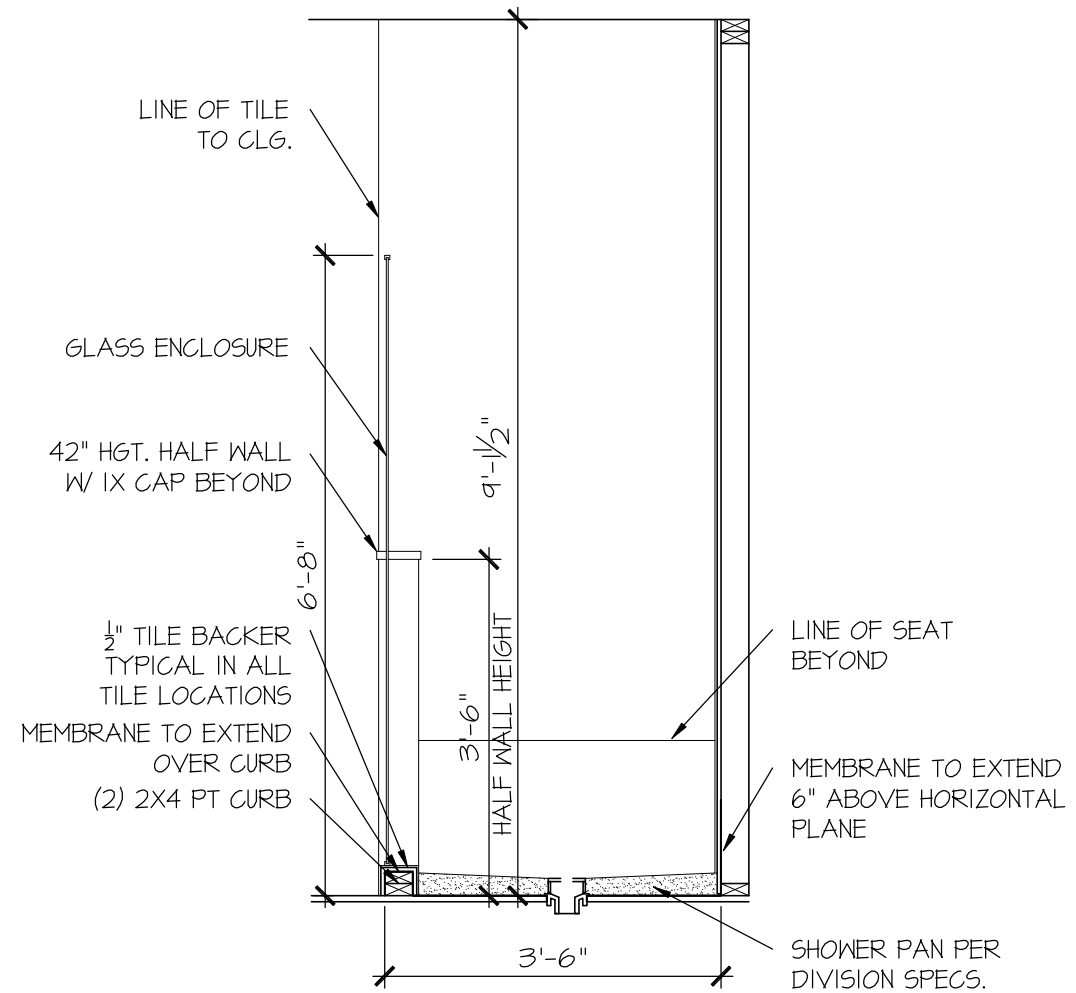

RALE TILE SHOWER  
SECTION C  
SCALE: 1/2" = 1'-0"

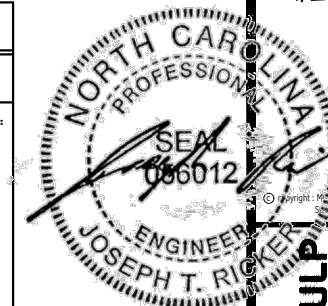

MULHERN+KULP  
RESIDENTIAL STRUCTURAL ENGINEERING  
300 Hammonds Ave., Building 4 - Auckler, PA 15802  
P: 717-948-8001 - mulhern@mkp.com  
NC LICENSE #C-3825

M&K project number:  
126-23061  
project mgr: JTR  
drawn by: SJF  
issue date: 01-08-24  
REVISIONS:  
date: initial:  
01-25-24 KFG



STRUCTURAL NOTES  
BLAKE POND COMMUNITY  
LOT 98 - STONEFIELD 4  
RALEIGH, NC

sheet:  
**SO.0**

### CONNECTION SPECIFICATIONS (TYP. U.N.O.)

DESCRIPTION OF BLDG. ELEMENT	3"x0.131" NAILS	3"x0.120" NAILS
JOIST TO SOLE PLATE	(3) TOENAILS	(3) TOENAILS*
SOLE PLATE TO JOIST/BLK'G.	(3) NAILS @ 4" o.c.	(3) NAILS @ 4" o.c.
STUD TO SOLE PLATE	(2) TOENAILS	(3) TOENAILS*
TOP OR SOLE PLATE TO STUD	(2) NAILS	(3) NAILS
RIM TO TOP PLATE	TOENAILS @ 8" o.c.	TOENAILS @ 6" o.c.*
BLK'G. BTWN. JOISTS TO TOP PL.	(3) TOENAILS	(3) TOENAILS*
DOUBLE STUD	NAILS @ 24" o.c.	NAILS @ 16" o.c.
DOUBLE TOP PLATE	NAILS @ 24" o.c.	NAILS @ 16" o.c.
DOUBLE TOP PLATE LAP SPLICE	(4) NAILS IN LAPPED AREA	(1) NAILS IN LAPPED AREA
TOP PLATE LAP @ CORNERS & INTERSECTING WALLS	(2) NAILS	(2) NAILS

\* 2 1/2"x0.113" IS AN ACCEPTABLE ALTERNATIVE TO A 3"x0.120", SAME SPACING OR NUMBER OF NAILS. (ONLY ACCEPTABLE WHERE \* ARE SHOWN)

### MEANS & METHODS NOTES

THE STRUCTURE IS DESIGNED TO BE SELF SUPPORTING AND STABLE AFTER THE BUILDING IS FINISHED AND ALL PLAN, DETAIL, AND NOTE SPECIFICATIONS HAVE BEEN COMPLETED. IT IS THE CONTRACTOR'S SOLE RESPONSIBILITY TO DETERMINE THE ERECTION PROCEDURES AND SEQUENCE TO INSURE THE SAFETY OF THE BUILDING AND ITS COMPONENTS DURING CONSTRUCTION. THIS INCLUDES, BUT IS NOT LIMITED TO, THE ADDITION OF NECESSARY SHORING, SHEETING, TEMPORARY BRACING, GUYS, AND TIE-DOWNS. CONTRACTOR SHALL BE RESPONSIBLE FOR ALL SHORING AND BRACING REQUIRED TO STABILIZE AND PROTECT EXISTING AND ADJACENT STRUCTURES AND SYSTEMS DURING COURSE OF DEMOLITION AND CONSTRUCTION OF THE PROJECT.

STRUCTURAL DESIGN AND SPECIFICATIONS ASSUME THAT ALL SUPPORTING AND NON-SUPPORTING ELEMENTS IN CONTACT WITH FLOOR FRAMING ARE LEVEL, INCLUDING, BUT NOT LIMITED TO; FOUNDATIONS, SLABS ON GRADE, BEAMS, WALLS, AND NON-BEARING ELEMENTS. IT IS THE CONTRACTOR'S RESPONSIBILITY TO VERIFY LEVELNESS AND MAKE ADJUSTMENTS AS NECESSARY, INCLUDING CONSIDERATION OF THOSE AREAS THAT MAY BE WITHIN CONTRACTUAL, INDUSTRY, OR WARRANTY TOLERANCES.

### ADDITIONAL NOTES FOR TRUSS & I-JOIST MANUFACTURER

ROOF TRUSS, FLOOR TRUSS AND ENGINEERED JOISTS SHALL BE DESIGNED TO MEET THE DIFFERENTIAL DEFLECTION CRITERIA BELOW, UNLESS NOTED OTHERWISE ON PLAN.

TRUSSES/JOISTS SHALL BE DESIGNED SO THAT DIFFERENTIAL DEFLECTION BETWEEN ADJACENT PARALLEL TRUSSES/JOISTS OR GIRDER TRUSSES/FLUSH BEAMS DO NOT EXCEED THE FOLLOWING:

- ROOF TRUSSES: 1/4" DEAD LOAD
- FLOOR TRUSSES, ATTIC TRUSSES, & I-JOISTS: 1/8" DEAD LOAD
- FLOOR TRUSSES & ATTIC TRUSSES ADJACENT TO FLOOR FRAMING BY OTHERS: LIMIT ABSOLUTE TRUSS DEFLECTION TO 3/16" DEAD LOAD. (NOT DIFFERENTIAL DEFLECTION)

### GENERAL STRUCTURAL NOTES

- DESIGN IS BASED ON 2018 NORTH CAROLINA STATE BUILDING CODE: RESIDENTIAL CODE.
- WOOD FRAME ENGINEERING IS BASED ON NDS, "NATIONAL DESIGN SPECIFICATION FOR WOOD CONSTRUCTION" - LATEST EDITION.
- DESIGN LOADS:  
ROOF DEAD = 7 PSF T.C., 10 PSF B.C.  
LIVE = 16 PSF  
LOAD DURATION FACTOR = 1.25  
FLOOR LIVE = 40 PSF (30 PSF @ SLEEPING AREAS)  
DEAD = 10 PSF (1-JOISTS & SOLID SAWN)  
10 PSF T.C., 5 PSF B.C. (TRUSSES)  
(ADDL. 10 PSF @ TILE)  
LATERAL 120 MPH, EXPOSURE B. SEISMIC A/B.  
SOIL 2,000 PSF ASSUMED ALLOWABLE BEARING PRESSURE (TO BE VERIFIED BY BUILDER)

### GENERAL FRAMING

- ALL TYP. NAIL FASTENER REQUIREMENTS ARE NOTED IN STANDARD CONNECTIONS TABLE OR ON PLANS. ALL NAILS SPECIFIED ARE MIN DIAMETER AND LENGTH REQUIRED FOR CONNECTION. ALL HANGER NAILS SHALL BE INSTALLED PER MANUFACTURER'S REQUIREMENTS FOR MAX CHARTED CAPACITY. NOTE: HANGERS USE COMMON NAIL DIAMETERS NOT TYPICAL FRAMING GUN NAILS.
- REFER TO FASTENING SCHEDULE TABLE R602.3(1) FOR ALL CONNECTIONS, TYP. U.N.O.
- EXT. & INT. BRG WALLS SHALL BE 2x4 OR 2x6 (AS SHOWN ON PLANS) @ 16" O.C. SFF OR 5/8" STUD GRADE LUMBER OR BETTER, U.N.O.  
• WALLS OVER 12' TALL SHALL BE PER PLAN.
- ALL HEADERS, BEAMS & OTHER STRUCTURAL MEMBERS SHALL BE SPRUCE-PINE-FIR #2 (SPP) OR SOUTHERN PINE #2 (SYP) LUMBER, OR BETTER (KILN-DRIED). ALL HEADERS HAVE BEEN DESIGNED BASED ON CALCULATED LOADS & SIZED ACCORDINGLY. CODE TABLES HAVE NOT BEEN USED.
- ALL NON-BEARING INTERIOR STUD WALLS SHALL BE CONSTRUCTED WITH 2x STUD GRADE MEMBERS SPACED @ 16" O.C. (MAX. U.N.O.)  
• HEADERS IN NON-LOAD BEARING WALLS SHALL BE: (1)2x4/6 FLAT @ OPENINGS UP TO 4'; (2)2x4/6 FLAT UP TO 8'.
- ALL FRAMING LUMBER SHALL BE DRIED TO 15% MC (KD-15).
- ENGINEERED LUMBER BEAMS TO MEET OR EXCEED THE FOLLOWING:  
• LSL' - Fb=2325 psi; Fv=310 psi; E=1.55x10<sup>6</sup> psi  
• LVL' - Fb=2600 psi; Fv=285 psi; E=2.0x10<sup>6</sup> psi  
• PSL' - Fb=2400 psi; Fv=240 psi; E=2.0x10<sup>6</sup> psi

- M&K SHALL BE FULLY INDEFINITE FOR ANY AND ALL ISSUES RESULTING FROM OR RELATED TO ANY BUILDING COMPONENT IF THE OWNER DOES NOT SUBMIT THE COMPONENT SHOP DRAWINGS TO M&K FOR STRUCTURAL REVIEW PRIOR TO FABRICATION, DELIVERY, OR INSTALLATION.
- FOR 2 & 3 PLY BEAMS OF EQUAL WIDTH, FASTEN PLYS TOGETHER WITH 3 ROWS OF 3"x0.120" NAILS @ 8" O/C OR 2 ROWS 1/4"x3/8" SIMPSON SDS SCREWS (OR 3/8" TRUSSLOK SCREWS) @ 16" O/C. USE A MINIMUM OF 3 ROWS FOR BEAM DEPTHS OF 14" OR GREATER. APPLY FASTENING AT BOTH FACES FOR 3-PLY CONDITION. LOCATE TOP & BOTTOM NAILS/SCREWS 2" FROM EDGE. SOLID 3 1/2" OR 5 1/4" BEAMS ARE ACCEPTABLE. USE 2 ROWS OF NAILS FOR 2x6 & 2x8 MEMBERS.
- FOR 4 PLY BEAMS OF EQUAL WIDTH, FASTEN PLYS TOGETHER WITH 3 ROWS OF 1/4"x6" SIMPSON SDS SCREWS (OR 6 3/8" TRUSSLOK SCREWS) @ 16" O/C. USE A MINIMUM OF 4 ROWS FOR BEAM DEPTHS OF 14" OR GREATER. APPLY FASTENING AT BOTH FACES (ONE SIDE ONLY FOR TRUSSLOK SCREWS). LOCATE TOP AND BOTTOM SCREWS 2" FROM EDGE. A SOLID 7" BEAM IS ACCEPTABLE.
- ALL HEADERS SHALL BE SUPPORTED BY (1)2x JACK STUD & (1)2x KING STUD, MINIMUM.  
- THE NUMBER OF STUDS SPECIFIED AT A SUPPORT INDICATES THE NUMBER OF JACK STUDS REQUIRED, U.N.O.
- ALL MULTI-PLY STUDS TO BE FASTENED TOGETHER W/ 3"x0.131" NAILS @ 24" O.C. (MIN), EACH PLY.
- PROVIDE SOLID BLOCKING IN FLOOR SYSTEM UNDER ALL POSTS CONTINUOUS TO FND/BEARING. BLOCKING TO MATCH POST ABOVE.
- FASTEN 2x WOOD PLATES TO TOP FLANGE OF STEEL BEAMS WITH P.A.F.'s (HILTI) X-CF PINS OR EQUAL @ 16" O.C. STAGGERED, OR 1/2" DIA. BOLTS @ 48" O.C. STAGGERED.
- ALL EXTERIOR 4x4 WOOD POSTS SHALL HAVE SIMPSON BC52-2/4 CAP & ABW44Z BASE, U.N.O.

### FLOOR FRAMING

- I-JOISTS/TRUSSES SHALL BE DESIGNED BY MANUF. TO MEET OR EXCEED L/480 LIVE LOAD DEFLECTION CRITERIA. (EXCLUDES MARBLE FLOORS - CONTACT M&K FOR MARBLE FLOOR DESIGNS)
- AT 1-JOIST FLOORS, PROVIDE 1 1/8" MIN. OSB RIM BOARD.
- METAL HANGERS SHALL BE SPECIFIED BY MANUFACTURER, U.N.O.
- FLOOR SHEATHING SHALL BE 23/32" A.P.A. RATED 'STURD-I-FLOOR' 24" O.C. EXPOSURE 1 (OR APPROVED EQUAL) WITH TONGUE AND GROOVE EDGES. FASTEN TO FRAMING MEMBERS W/ GLUE AND - 2 1/4" x 0.131" NAILS @ 6" o.c. @ PANEL EDGES & @ 12" o.c. FIELD.  
- 2 3/8" x 0.120" NAILS @ 4" o.c. @ PANEL EDGES & @ 8" o.c. FIELD.  
- 2 3/8" x 0.113" NAILS @ 3" o.c. @ PANEL EDGES & @ 6" o.c. FIELD.  
- 1/2" x 2" MIN. SCREWS @ 6" o.c. @ PANEL EDGES & @ 12" o.c. FIELD.

### ROOF FRAMING

- BAY WINDOWS & SHED ROOFS (UP TO 6' SPAN) CAN BE 2x4 OR 2x6 RAFTERS & CEILING JOISTS @ 16/24" O.C.
- FASTEN EACH ROOF TRUSS TO TOP PLATE W/ SIMPSON H25T CLIP (OR APPROVED EQUAL) @ ALL BEARING POINTS. PROVIDE (2) H25T CLIPS AT 2-PLY GIRDER TRUSSES, (3) H25T CLIPS AT 3-PLY GIRDER TRUSSES & ROOF BEAMS - AT ALL BEARING POINTS.
- METAL HANGERS SHALL BE SPECIFIED BY THE MANUFACTURER, U.N.O.
- ERECT AND INSTALL ROOF TRUSSES PER WTCA & TPI'S BC51 I-08 "GUIDE TO GOOD PRACTICE FOR HANDLING, INSTALLING & BRACING OF METAL PLATE CONNECTED WOOD TRUSSES."
- SUPPORT PORCH & SHORT SPAN ROOF TRUSSES (MAX 7' SPAN) W/ 2x4 LEDGER FASTENED TO:  
- RIM BOARD W/ (2) 3"x0.131" NAILS @ 16" O.C. MAX. (1-JOISTS)  
- TRUSS VERTICALS W/ (3) 3"x0.131" NAILS @ 19.2" O.C. MAX. (FLOOR TRUSSES)
- ROOF SHEATHING SHALL BE 7/16" A.P.A. RATED SHEATHING 24/16 EXPOSURE 1 (OR APPROVED EQUAL). FASTEN TO FRAMING MEMBERS  
- W/ 2 1/4" x 0.131" NAILS @ 6" o.c. @ PANEL EDGES & @ 12" o.c. FIELD.  
- W/ 2 3/8" x 0.120" NAILS @ 4" o.c. @ PANEL EDGES & @ 8" o.c. FIELD.  
- W/ 2 3/8" x 0.113" NAILS @ 3" o.c. @ PANEL EDGES & @ 6" o.c. FIELD.

### VENEER LINTEL SCHEDULE

SPAN (MAX)	HEIGHT OF VENEER ABOVE LINTEL	STEEL ANGLE SIZE
3'-0"	20 FT. MAX	L3"x3"x1/2"
	3 FT. MAX	L3"x3"x1/2"
6'-0"	12 FT. MAX	L4"x4"x1/2"
	20 FT. MAX	L5"x5"x3/8"
8'-0"	3 FT. MAX	L4"x4"x1/2" *
	12 FT. MAX	L5"x5"x3/8"
9'-6"	16 FT. MAX	L6"x6"x3/8"
	12 FT. MAX	L6"x6"x3/8"
16'-0"	2 FT. MAX	L7"x4"x1/2" **
	3 FT. MAX	L8"x4"x1/2" **

ALL LINTELS:  
 - SHALL SUPPORT 2 1/2" - 3 1/2" VENEER W/ 40 PSF MAXIMUM HEIGHT.  
 - 16" SHALL HAVE 4" MIN. BEARING  
 - 16" SHALL NOT BE FASTENED BACK TO HEADER  
 - 16" SHALL BE FASTENED BACK TO WOOD HEADER IN WALL @ 48" o.c. W/ 1/2" DIA. x 5 1/2" LONG LAG SCREWS IN 2" LONG VERTICALLY SLOTTED HOLES.  
 - MAX VENEER HT. APPLIES TO ANY PORTION OF BRICK OVER THE OPENING.  
 - ALL LINTELS SHALL BE LONG LESS VERTICAL.  
 - WHEN SUPPORTING VENEER < 8" WIDE THE EXTERIOR TOE OF THE HORIZONTAL LEG MAY BE CUT IN THE FIELD TO BE 3/4" WIDE OVER THE BEARING LENGTH ONLY. THIS IS TO ALLOW FOR HORIZONTAL JOINT FINISHING.  
 - SEE STRUCTURAL PLANS FOR ANY LINTEL CONDITION NOT ENCOMPASSED BY THE ABOVE PARAMETERS.  
 \* FOR GREEN VENEER USE L4x3x1/2".  
 \*\* FOR 3/2" VENEER ONLY. SEE PLAN FOR VENEER SUPPORT IF VENEER < 3/2" THICK.

**SD2.I REFERS TO SD2.IA FOR LVL/PSL/LSL BEAMS OR SD2.IB FOR FLITCH BEAMS OR SD2.IC FOR STEEL BEAMS**

### LATERAL BRACING & SHEAR WALL SHEATHING SPECIFICATIONS

THIS MODEL HAS BEEN DESIGNED TO RESIST LATERAL FORCES RESULTING FROM:  
**120 MPH WIND IN 2018 NC5BC:RC**  
 (120 MPH WIND SPEED IN ASCE 7-10 WIND MAP, PER IRC R301.2.1.1) EXP. B, RISK CAT. 2 & SEISMIC CAT. A/B.

THE DESIGN WAS COMPLETED PER 2015 IBC (SECTION 1609) & ASCE 7-10, AS PERMITTED BY R301.1.3 OF THE 2018 NC5BC:RC, OR THE SIMPLIFIED PRESCRIPTIVE PROCEDURE IN ACCORDANCE WITH THE 2015 IRC IF THE PARAMETERS OF SECTION R602.12 COMPLY. ACCORDINGLY, THIS MODEL, AS DOCUMENTED AND DETAILED HEREIN, IS ADEQUATE TO RESIST THE CODE REQUIRED LATERAL FORCES.

DESIGN WIND UPLIFT LOADS HAVE BEEN CALCULATED UTILIZING ASCE 7-10 (ACCEPTED ENGINEERING PRACTICE) AS ALLOWED PER 2018 NC5BC:RC SECTION R802.11.1.1. THIS MODEL HAS BEEN DETAILED WHERE REQUIRED & ENGINEERED TO RESIST THE WIND UPLIFT LOAD PATH PER SECTIONS R602.3.5 & R802.11.

### EXT. WALL SHEATHING SPECIFICATION

- 7/16" OSB OR 15/32" PLYWOOD:  
FASTEN SHEATHING W/ 2 3/8" x 0.113" NAILS @ 6" O.C. AT EDGES & @ 12" O.C. IN THE PANEL FIELD. TYP. U.N.O.
- HORIZONTAL BLOCKING OF EXT. WALL/SHEAR WALL PANEL EDGES IS NOT REQUIRED BY THIS DESIGN EXCEPT FOR THOSE AREAS SPECIFICALLY NOTED.
- ALL EXT. WALLS SHALL BE CONTINUOUSLY SHEATHED AND ARE CONSIDERED SHEAR WALLS.
- ALT. STAPLE CONNECTION SPEC: 1 1/2" 16 GA STAPLES (1/2" CROWN) @ 3" O.C. AT EDGES & @ 6" O.C. IN FIELD.

### BLOCKED PANEL EDGES

- AT DESIGNATED AREAS - FASTEN SHEATHING W/ 2 3/8" x 0.113" NAILS @ 6" O.C. AT ALL PANEL EDGES AND 12" O.C. IN THE PANEL FIELD OR 1 3/4" 16 GA STAPLES (1/2" CROWN) @ 3" O.C. AT EDGES & @ 6" O.C. IN FIELD. ALL SHEATHING PANELS SHALL BE ORIENTED AND INSTALLED FULL HEIGHT OF SHEAR WALL OR 2x HORIZONTAL BLOCKING SHALL BE PROVIDED TO SUPPORT ALL UNSUPPORTED PANEL EDGES & EDGE FASTENING.

### 3" O.C. EDGE NAILING

- AT DESIGNATED AREAS - FASTEN PANEL EDGES OF WOOD STRUCTURAL WALL SHEATHING TO FRAMING W/ 8d NAILS @ 3" O.C. NO STAPLE ALTERNATIVE AVAILABLE AT THIS SPEC. ALL SHEATHING PANELS SHALL BE ORIENTED AND INSTALLED FULL HEIGHT OF SHEAR WALL OR 2x HORIZONTAL BLOCKING SHALL BE PROVIDED TO SUPPORT UNSUPPORTED PANEL EDGES AND 3" O.C. EDGE FASTENING.

### NOTES

- SEE CONNECTION SPECIFICATIONS CHART FOR STANDARD SHEAR TRANSFER DETAILING. IF ADDITIONAL CAPACITY IS REQUIRED BY DESIGN, IT WILL BE SPECIFICALLY NOTED ON PLAN.
- DESIGN ASSUMES 16" O.C. MAX. STUD SPACING, U.N.O.
- ALL STRUCTURAL PANELS ARE TO BE DIRECTLY APPLIED TO STUD FRAMING.
- PRE-MANUFACTURED PANELIZED WALLS: FASTEN TOGETHER END STUDS OF WALL PANELS SHEATHED W/ OSB OR PLYWOOD W/ 3" x 0.120" NAILS @ 4" O.C. (THRU ONE SIDE ONLY)

--- INDICATES EXTENT OF INT. OSB SHEARWALL OR 3" O.C. OSB SHEARWALL.  
 ▸ INDICATES HOLD-DOWN BELOW

### GENERAL STRUCTURAL NOTES

#### FOUNDATION

- DESIGN IS BASED ON 2018 NORTH CAROLINA STATE BUILDING CODE: RESIDENTIAL CODE.
- FOOTING DESIGN - 2,000 PSF ALLOWABLE SOIL BEARING PRESSURE IS ASSUMED. BUILDER/CONTRACTOR MUST VERIFY.
- FASTEN 2x4/6 SILL PLATES TO FND WITH A MINIMUM OF 2 ANCHORS PER PLATE, 12" MAX. FROM PLATE ENDS - UTILIZING:  
• 1/2" DIA. ANCHOR BOLTS @ 6'-0" O.C., 7" MIN. EMBEDMENT (CONC), 15" MIN. EMBEDMENT (CMU)  
• SIMPSON MASA ANCHOR STRAPS @ 6'-0" O.C. (CONC)  
• SIMPSON MAB23 ANCHOR STRAPS @ 2'-8" O.C. (CMU)  
(REFER TO DETAILS FOR 10' TALL WALL ANCHOR REQUIREMENTS)
- ALL LUMBER EXPOSED TO WEATHER OR IN CONTACT W/ CONCRETE OR CMU SHALL BE PRESERVATIVE TREATED SOUTHERN PINE #2.
- BUILDER TO VERIFY CORROSION-RESISTANCE COMPATIBILITY OF HARDWARE & FASTENERS IN CONTACT W/ PRESERVATIVE-TREATED WOOD. CONTACT LUMBER & HARDWARE SUPPLIERS TO COORD.
- BASEMENT INTERIOR BEARING WALLS & EXTERIOR WALK-OUT BASEMENT WALLS SHALL BE 2x6 @ 16" O.C. SFF OR 5/8" STUD GRADE OR BETTER.
- CONCRETE DESIGN BASED ON ACI 318. CONCRETE SHALL ATTAIN THE FOLLOWING MIN. COMPRESSIVE STRENGTHS IN 28 DAYS, U.N.O.:  
f'c = 4,000 psi: ..... FOUNDATION WALLS  
2,500 psi: ..... FOOTINGS & INTERIOR SLABS ON GRADE  
3,000 psi: ..... GARAGE & EXTERIOR SLABS ON GRADE  
fy = 60,000 psi
- BASEMENT FOUNDATION WALL DESIGN BASED ON:  
• 9" OR 10" HEIGHT (AS NOTED ON PLANS)  
• TALLER WALLS MUST BE ENGINEERED.  
• NOMINAL WIDTH (1 1/2" FOR 10" THICK WALL).
- BASEMENT WALL DESIGN IS BASED ON 60 PCF BACKFILL SOIL TYPE CLASSIFICATIONS (SC, ML-CL, OR CL).
- BASEMENT WALLS SHALL BE BRACED, PRIOR TO BACKFILLING, BY ADEQUATE TEMPORARY BRACING OR INSTALL 1st FLOOR DECK.
- PROVIDE (2) #5 BARS AROUND ALL SIDES OF OPENINGS IN CONCRETE BSMT. FND. WALL WITH 2" CLEAR. REINFORCEMENT SHALL EXTEND 12" PAST CORNER OF OPENING IN ALL DIRECTIONS.  
• FOR OPENINGS UP TO 36", PROVIDE MINIMUM 10" CONCRETE DEPTH OVER OPENING OR (3)2x10 W/ (2)2x6 JACK STUDS, U.N.O.  
• LARGER OPENINGS SHALL BE PER PLAN.
- ALL CONCRETE EXPOSED TO THE WEATHER SHALL NOT HAVE LESS THAN 5% OR MORE THAN 7% AIR ENTRAINMENT.
- ALL FOOTINGS SHALL BEAR AT LEAST 12" BELOW FINISH GRADE.
- FOOTINGS AND SLABS ON GRADE SHALL BEAR ON VIRGIN SOIL OR 45% COMPACTED FILL.
- PROVIDE CONTROL JOINTS AT ALL INSIDE CORNERS OF SLAB EDGES, AND OTHER LOCATIONS WHERE SLAB CRACKS ARE LIKELY TO DEVELOP.  
• JOINTS SHALL BE LOCATED @ 10'-0" O.C. (RECOMMENDED) OR 15'-0" O.C. (MAXIMUM)  
• JOINT GRID PATTERN SHALL BE AS CLOSE TO SQUARES AS POSSIBLE (1:1 RATIO), WITH A MAXIMUM OF 1:1.5 RATIO  
• CONTROL JOINTS SHALL NOT BE INSTALLED IN STRUCTURAL SLABS
- CONCRETE MASONRY UNITS (CMU) SHALL BE ASTM C90 WITH A MIN. COMPRESSIVE STRENGTH OF 1400 psi (Fm=1500 psi). MORTAR SHALL BE ASTM C270, TYPE S. CMU DESIGN PER ACI 530 & 530.1.
- CMU FOUNDATION WALLS SHALL HAVE 'DUR-O-WALL' HORIZONTAL JOINT REINFORCEMENT (OR EQUAL) - 9 GA. MINIMUM @ 16" O.C.
- PROVIDE 2x8 x 16" LONG P.T. PLATE ON TOP OF ALL CRAML SPACE PIERS. ALL PIERS SHALL BE GROUTED SOLID.
- PROVIDE 2x6 P.T. PLATE ON INTERIOR CRAML SPACE WALLS, FASTENED PER ANCHORAGE SPECIFICATION NOTED ABOVE.
- DIMENSIONS BY OTHERS, BUILDER TO VERIFY.
- BUILDER TO VERIFY THAT MODEL HAS BEEN ADEQUATELY TREATED BY A LICENSED AND BONDED PEST CONTROL COMPANY FOR SUBTERRANEAN TERMITES. METHOD AND TYPE OF TREATMENT TO BE DETERMINED BY PEST CONTROL COMPANY.

### HOLD-DOWN SCHEDULE

SYMBOL	SPECIFICATION
▸ HD-1	SIMPSON HTT4 HOLD-DOWN *
▸ HD-2	SIMPSON MSTC66 STRAP TIE (CENTER STRAP ON FLOOR SYSTEM U.N.O.) (PRE-BENT MSTC66 ALT. WHEN SPECIFIED)
▸ HD-3	SIMPSON 5THD14/14RJ HOLD-DOWN

ALTERNATIVE TO S6TB24 ANCHOR BOLT SPECIFICATION:  
 \* UTILIZE SIMPSON "SET" EPOXY SYSTEM TO FASTEN 3/8" DIA. THREADED ROD INTO CONCRETE FOUNDATION. PROVIDE 12" MIN. EMBEDMENT INTO CONCRETE. INSTALL PER MANUF. RECOMMENDATIONS. DO NOT LOCATE ANCHORS WITHIN 1 3/4" OF EDGE OF FOUNDATION.

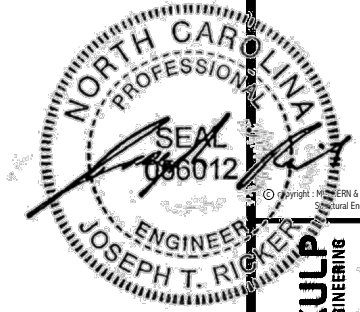

**MULHERN+KULP**  
RESIDENTIAL STRUCTURAL ENGINEERING  
303 Dunsmuir Ave, Building 4 - Auckler, PA 15022  
P 715-948-8001 - mulhern+kulp.com  
NC LICENSE #C-3825



M&K project number:  
126-23061  
project mgr: JTR  
drawn by: SJF  
issue date: 01-08-24

REVISIONS:  
date: 01-25-24 initial: KFG



FOUNDATION PLANS  
BLAKE POND COMMUNITY  
LOT 98 - STONEFIELD 4  
RALEIGH, NC

Sheet:  
**S1.0**

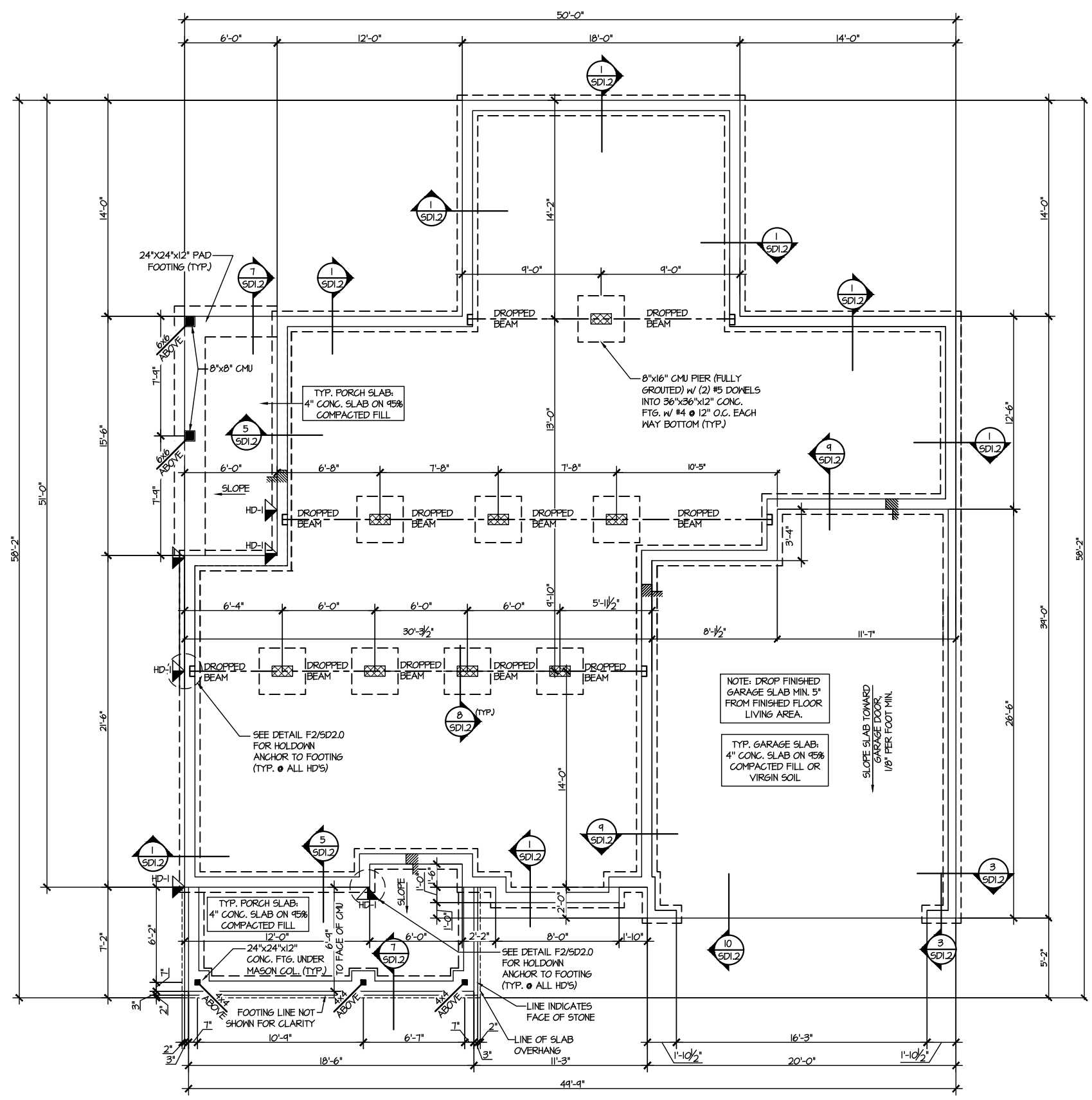

**1 CRAWL SPACE FOUNDATION PLAN**  
SCALE: 1/8"=1'-0"

LEGEND	
	INTERIOR BEARING WALL
	BEARING WALL ABOVE
	BEAM / HEADER
	INDICATES SHEAR WALL & EXTENT
	EXTENT OF OVERFRAMING
	JL METAL HANGER
	* INDICATES POST ABOVE. PROVIDE SOLID BLOCKING UNDER POST OR JAMB ABOVE.
	▶ INDICATES HOLD-DOWN OR STRAP. REFER TO SCHEDULE.

**REFER TO 50.0 FOR TYPICAL STRUCTURAL NOTES & SCHEDULES**





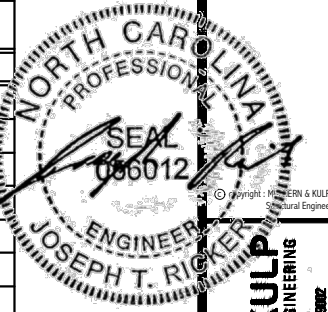

**MULHERN+KULP**  
RESIDENTIAL STRUCTURAL ENGINEERING  
310 Rembrandt Ave., Building 4 - Aankar, PA 15802  
P: 717-948-8001 • mulhern+kulp.com  
NC LICENSE #C-3825

M&K project number:  
126-23061  
project mgr: JTR  
drawn by: SJF  
issue date: 01-08-24  
REVISIONS:  
date: initial:  
01-25-24 KFG



FLOOR FRAMING PLANS  
BLAKE POND COMMUNITY  
LOT 98 - STONEFIELD 4  
RALEIGH, NC

sheet:  
**S3.0**

**ENGINEERED BEAM MATERIAL SCHEDULE**

BEAM NUMBER	LVL OPTION	PSL OPTION	LSL OPTION	FLITCH OPTION	STEEL OPTION
001	(2)3/4"x16" - D	3 1/2"x16" - D	N/A	(2)2x12 + (1) 3/4"x11 1/2" STEEL FLITCH PLATES - D	W12x14 - D
002	(2)3/4"x11 1/2" - D	3 1/2"x11 1/2" - D	(3)3/4"x11 1/2" - D	(2)2x12 + (1) 1/4"x11 1/2" STEEL FLITCH PLATES - D	W12x14 - D
003	(2)3/4"x14" - F	3 1/2"x14" - F	(2)3/4"x14" - F	(2)2x12 + (1) 1/4"x14" STEEL FLITCH PLATES - F	W12x14 - F
004	(2)3/4"x14" - F	3 1/2"x14" - F	(3)3/4"x14" - F	(2)2x12 + (1) 3/4"x14" STEEL FLITCH PLATES - F	W12x14 - F
005	(3)3/4"x10" - FT	5 1/4"x10" - FT	N/A	(3)2x12 + (2) 3/4"x10" STEEL FLITCH PLATES - F	W12x26 - F
006	(3)3/4"x10" - FT	5 1/4"x10" - FT	N/A	(3)2x12 + (2) 3/4"x10" STEEL FLITCH PLATES - F	W12x26 - F
007	(2)3/4"x14" - F	3 1/2"x14" - F	(2)3/4"x14" - F	(2)2x12 + (1) 1/4"x14" STEEL FLITCH PLATES - F	W12x14 - F
008	(2)3/4"x14" - F	3 1/2"x14" - F	(2)3/4"x14" - F	(2)2x12 + (1) 1/4"x14" STEEL FLITCH PLATES - F	W12x14 - F
009	(2)3/4"x9 1/2" - D	3 1/2"x9 1/2" - D	(2)3/4"x9 1/2" - D	(2)2x10 + (1) 1/4"x9 1/2" STEEL FLITCH PLATES - D	W10x12 - D
010	(2)3/4"x16" - H	3 1/2"x16" - H	(3)3/4"x16" - H	(3)2x12 + (2) 1/2"x16" STEEL FLITCH PLATES - H	N/A
011	(2)3/4"x11 1/2" - D	3 1/2"x11 1/2" - D	(3)3/4"x11 1/2" - D	(2)2x12 + (1) 1/4"x11 1/2" STEEL FLITCH PLATES - D	W12x14 - D
012	(3)3/4"x16" - D	5 1/4"x16" - D	(4)3/4"x16" - D	(3)2x12 + (2) 1/2"x16" STEEL FLITCH PLATES - D	W12x14 - D
013	(2)3/4"x11 1/2" - D	3 1/2"x11 1/2" - D	(3)3/4"x11 1/2" - D	(2)2x12 + (1) 1/4"x11 1/2" STEEL FLITCH PLATES - D	W12x14 - D
014	(2)3/4"x16" - D	3 1/2"x16" - D	(3)3/4"x16" - D	(3)2x12 + (2) 3/4"x16" STEEL FLITCH PLATES - D	W12x14 - D
015**	(3)3/4"x11 1/2" - D	N/A	(3)3/4"x11 1/2" - D	(3)2x12 + (2) 1/4"x11 1/2" STEEL FLITCH PLATES - D	W12x14 - D
016	(2)3/4"x11 1/2" - F	3 1/2"x11 1/2" - F	(3)3/4"x11 1/2" - F	(2)2x12 + (1) 1/4"x11 1/2" STEEL FLITCH PLATES - F	W12x14 - F

- BEAM NOTATION:**
- "F" INDICATES FLUSH BEAM
  - "FT" INDICATES FLUSH TOP BEAM
  - "FB" INDICATES FLUSH BOTTOM BEAM
  - "D" INDICATES DROPPED BEAM
  - "H" INDICATES DROPPED OPENING HEADER
- REFER TO DETAIL D/SD2.0 FOR TYPICAL FLITCH BEAM CONNECTIONS  
REFER TO DETAIL E/SD2.0 FOR TYPICAL STEEL BEAM CONNECTIONS  
FOR FLUSH TOP BEAMS PROVIDE 2X STACKED PLATES BENEATH BEAM AS REQ'D. FASTEN PLATES IN SUCCESSION W/ (2) 3"x0.120" NAILS @ 8" O.C.  
FOR FLUSH BOTTOM BEAMS PROVIDE 2X STACKED PLATES ATOP BEAM AS REQ'D. FASTEN PLATES IN SUCCESSION W/ (2) 3"x0.120" NAILS @ 8" O.C.
- \*\*\* - SEE PLAN FOR EXTENT OF 3-PLY BEAM

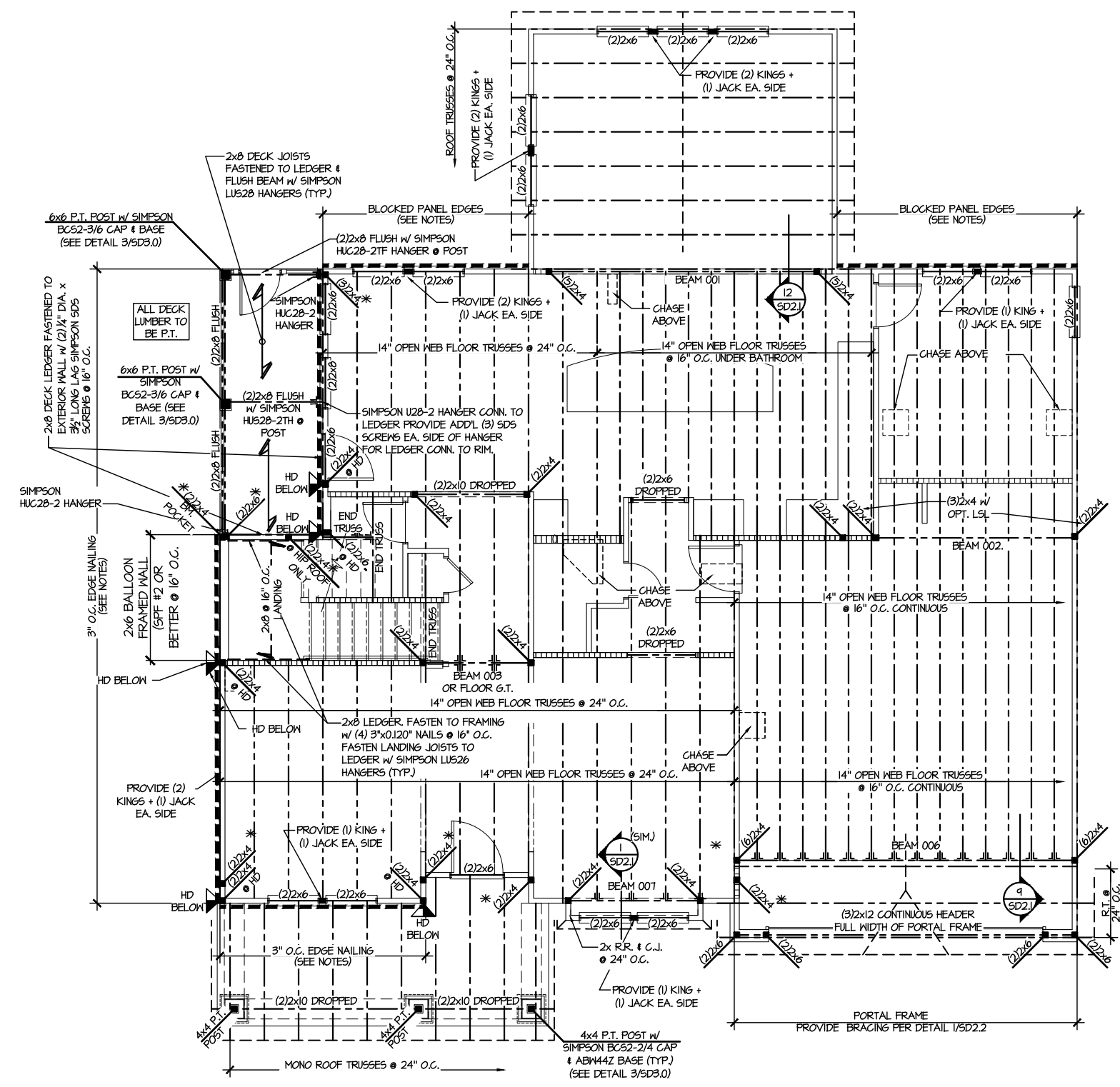

**2ND FLOOR FRAMING PLAN**  
SCALE: 1/8"=1'-0"

**SD2.1 REFERS TO SD2.1A FOR LVL/PSL/LSL BEAMS OR SD2.1B FOR FLITCH BEAMS OR SD2.1C FOR STEEL BEAMS**

**LEGEND**

- INTERIOR BEARING WALL
- BEARING WALL ABOVE
- BEAM / HEADER
- INDICATES SHEAR WALL & EXTENT
- EXTENT OF OVERFRAMING
- L METAL HANGER
- \* INDICATES POST ABOVE. PROVIDE SOLID BLOCKING UNDER POST OR JAMB ABOVE.
- ▶ INDICATES HOLD-DOWN OR STRAP. REFER TO SCHEDULE.

**REFER TO 50.0 FOR TYPICAL STRUCTURAL NOTES & SCHEDULES**

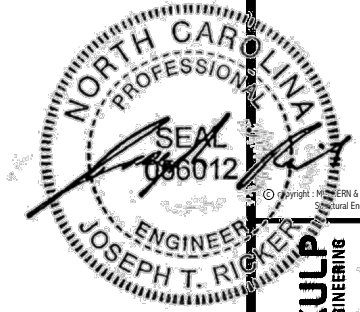

**MULHERN+KULP**  
RESIDENTIAL STRUCTURAL ENGINEERING  
300 Bantamside Ave, Building 4 - Aankler, PA 15022  
P 715-948-5001 • mulhern+kulp.com  
NC LICENSE #C-3825



M&K project number:  
126-23061  
project mgr: JTR  
drawn by: SJF  
issue date: 01-08-24

REVISIONS:  
date: 01-25-24 initial: KFG



ROOF FRAMING PLANS  
BLAKE POND COMMUNITY  
LOT 98 - STONEFIELD 4  
RALEIGH, NC

sheet:  
**S4.0**

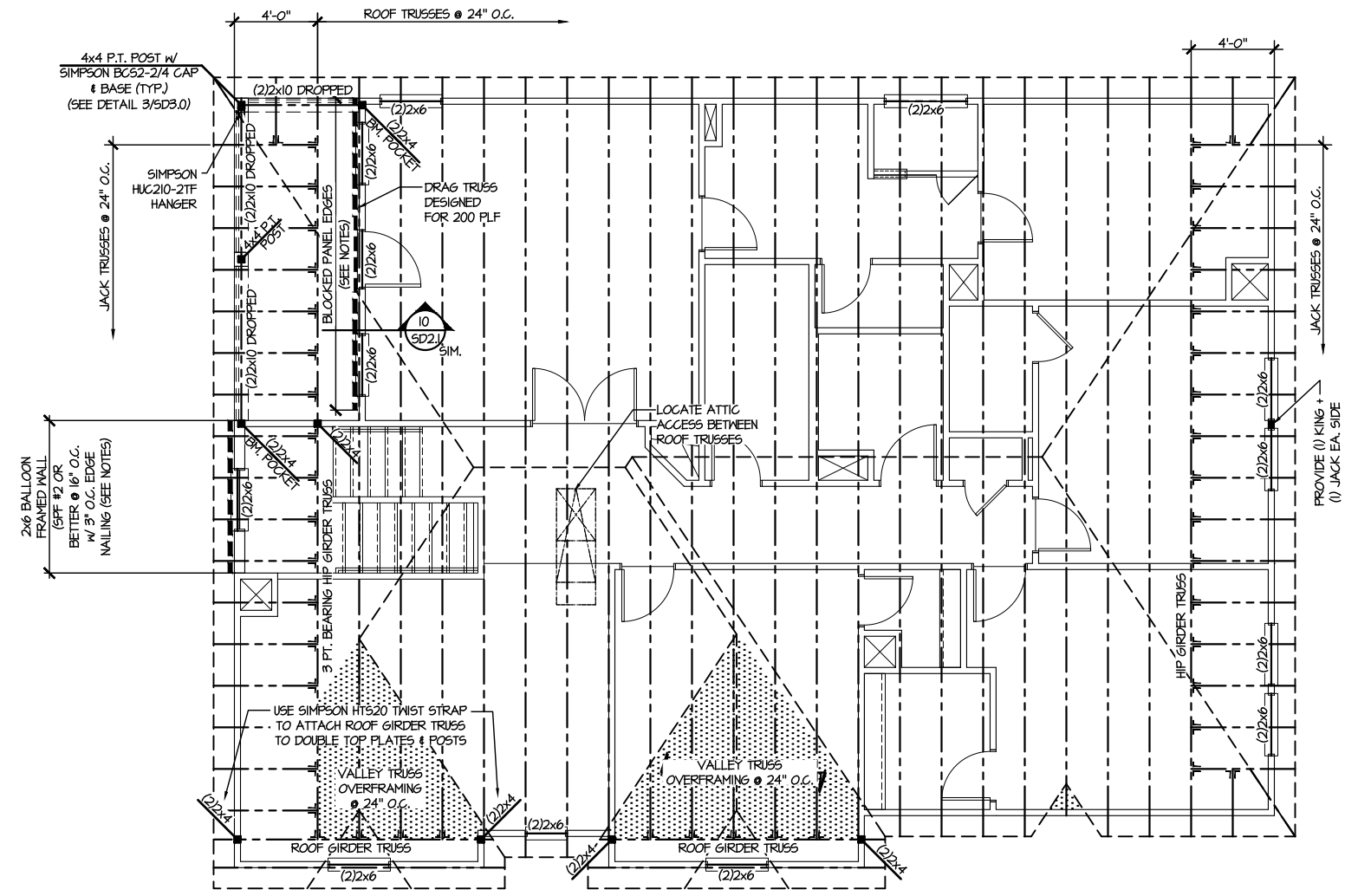

**1 ROOF FRAMING PLAN**  
SCALE: 1/8" = 1'-0"

LEGEND	
	INTERIOR BEARING WALL
	BEARING WALL ABOVE
	BEAM / HEADER
	INDICATES SHEAR WALL & EXTENT
	EXTENT OF OVERFRAMING
	HL METAL HANGER
	* INDICATES POST ABOVE. PROVIDE SOLID BLOCKING UNDER POST OR JAMB ABOVE.
	▶ INDICATES HOLD-DOWN OR STRAP. REFER TO SCHEDULE.

REFER TO 50.0 FOR  
TYPICAL STRUCTURAL NOTES  
& SCHEDULES



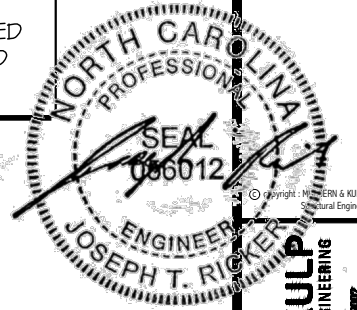

MULHERN+KULP  
RESIDENTIAL STRUCTURAL ENGINEERING  
330 Bannockburn Ave., Building 4 - Asheville, PA 18027  
P 215-692-8001 - mulhern@mkulpe.com



M&K project number:  
126-23061  
project mgr: JTR  
drawn by: SJF  
issue date: 01-08-24

REVISIONS:  
date: initial:  
01-25-24 KFG

**DRB**  
**HOMES**

FOUNDATION DETAILS  
BLAKE POND COMMUNITY  
LOT 98 - STONEFIELD 4  
RALEIGH, NC

sheet:  
**SD1.2**

LETTERED DETAILS ARE TYPICAL FOR THIS HOME & SHALL BE IMPLEMENTED IN ALL APPLICABLE AREAS. THESE DETAILS ARE NOT "CUT" ON THE PLANS.

NUMBERED DETAILS ARE PLAN SPECIFIC AND ARE ONLY REQUIRED WHERE SPECIFICALLY INDICATED ("CUT") ON THE PLANS.

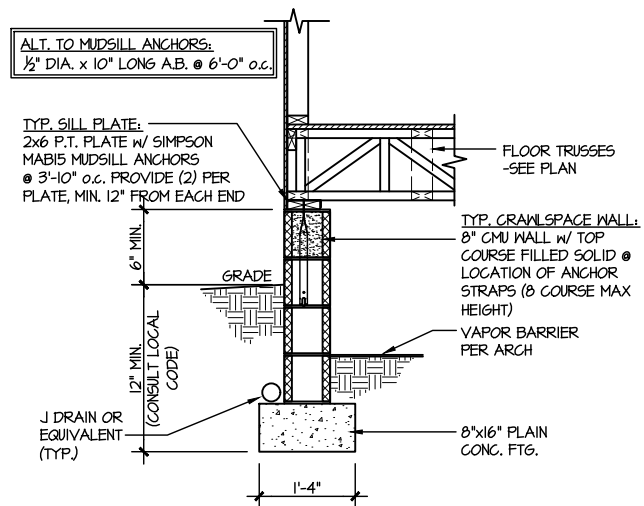

**1** TYPICAL CRAWLSPACE FOUNDATION  
SCALE: 3/8"=1'-0"

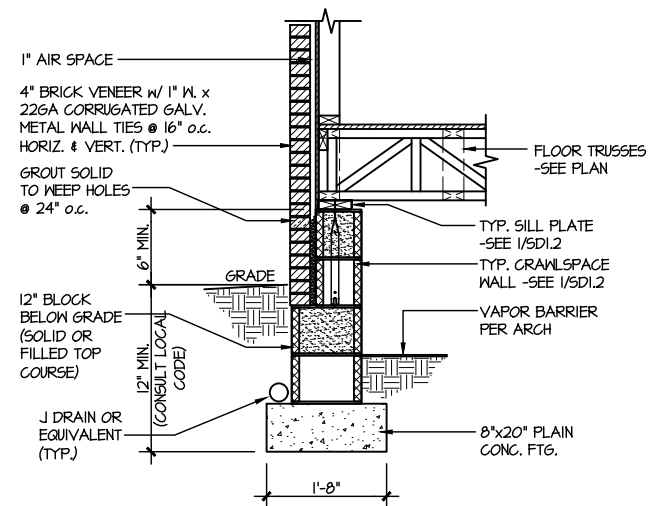

**2** TYPICAL CRAWLSPACE FOUNDATION  
SCALE: 3/8"=1'-0" W/ BRICK VENEER

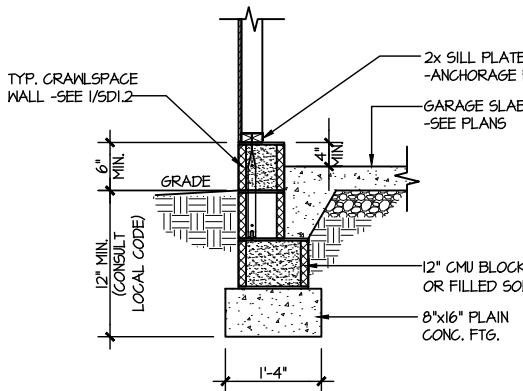

**3** TYPICAL GARAGE FOUNDATION  
SCALE: 3/8"=1'-0"

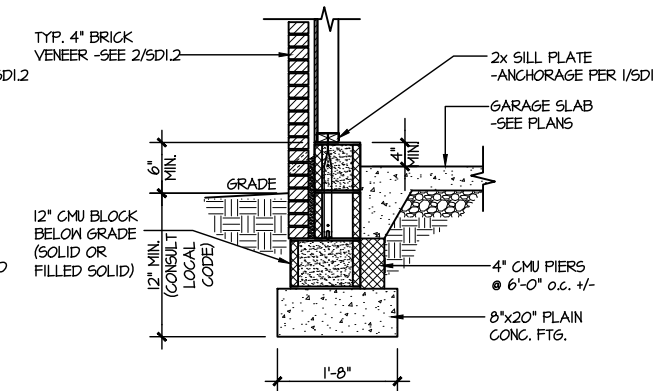

**4** TYPICAL GARAGE FOUNDATION  
SCALE: 3/8"=1'-0" W/ BRICK VENEER

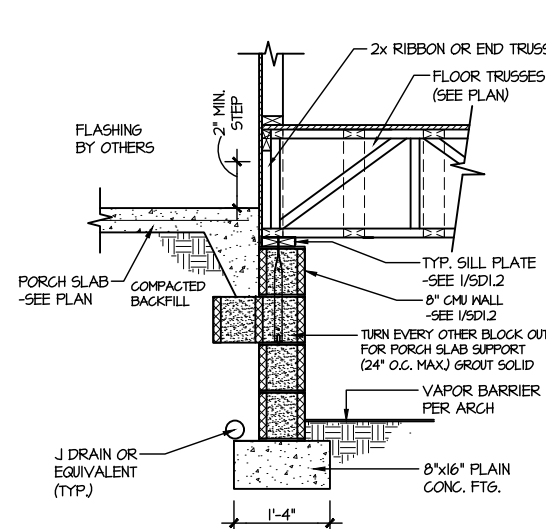

**5** TYPICAL CRAWLSPACE FOUNDATION @ PORCH/PATIO SLAB  
SCALE: 3/8"=1'-0"  
(REFER TO DETAIL 12 FOR WOOD PORCH OPTION)

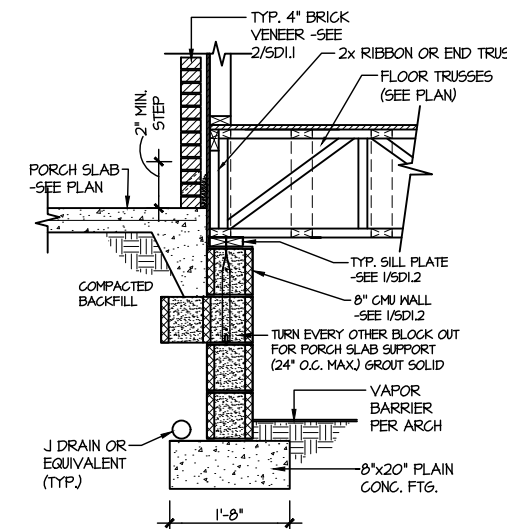

**6** TYPICAL CRAWLSPACE FOUNDATION @ PORCH/PATIO SLAB  
SCALE: 3/8"=1'-0" W/ BRICK VENEER

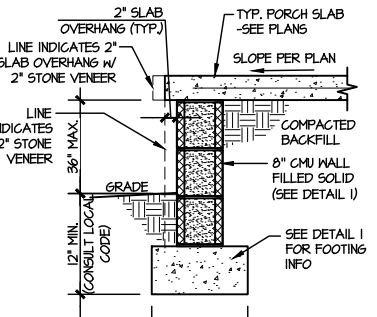

**7A** TYP. FOOTING @ PORCH SLAB  
SCALE: 3/8"=1'-0"

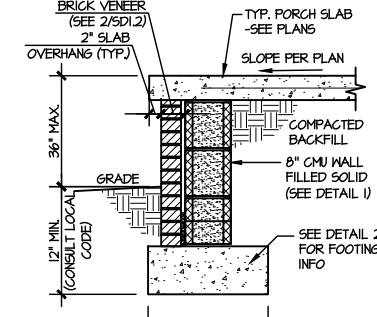

**7B** TYP. FOOTING @ PORCH SLAB  
SCALE: 3/8"=1'-0" W/ BRICK VENEER

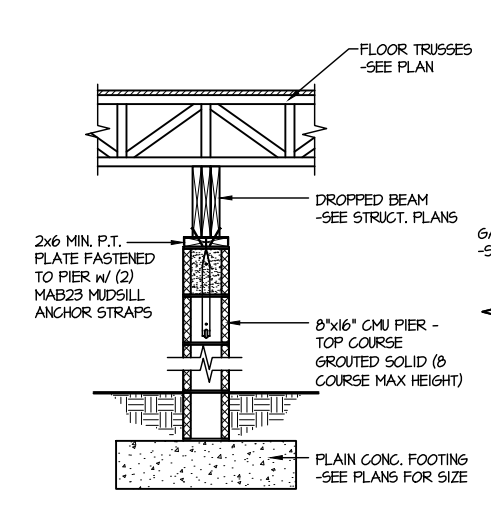

**8** TYPICAL CRAWLSPACE FND. @ INTERIOR PIER  
SCALE: 3/8"=1'-0"

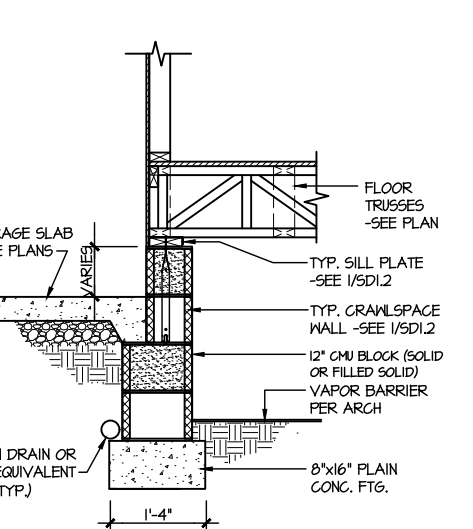

**9** TYPICAL CRAWLSPACE FOUNDATION @ GARAGE  
SCALE: 3/8"=1'-0"

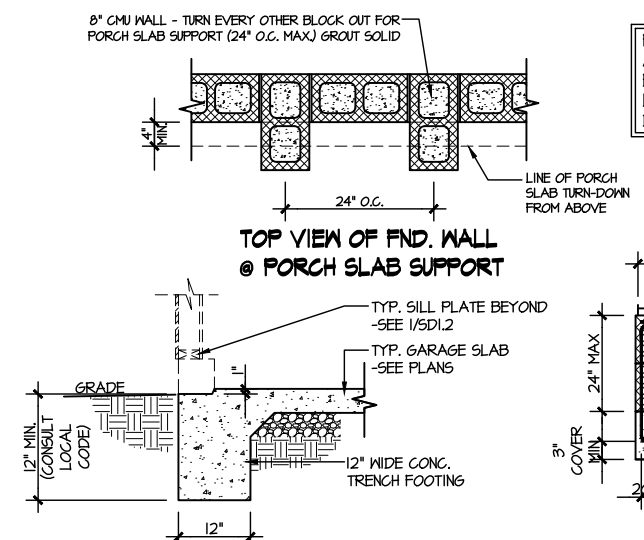

**10** TYPICAL SLAB ON GRADE GARAGE ENTRY @ PERIMETER FOOTING  
SCALE: 3/8"=1'-0"

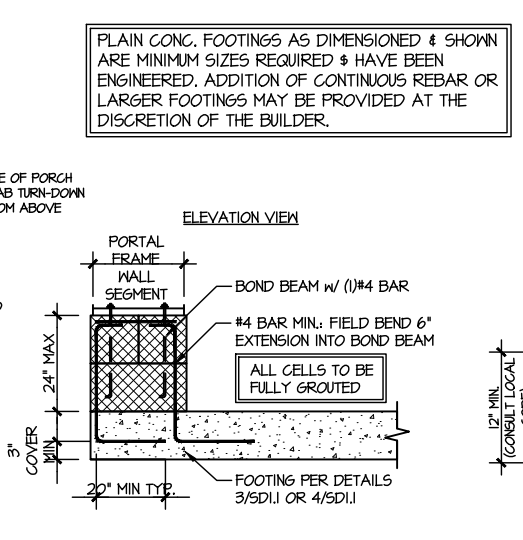

**A** GARAGE PORTAL FRAME STEM WALL REINFORCEMENT  
SCALE: 3/8"=1'-0"

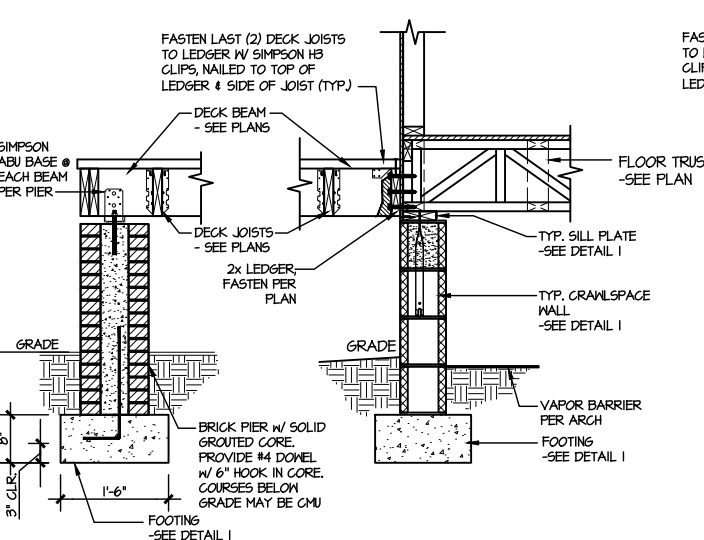

**11** TYPICAL CRAWLSPACE FOUNDATION @ WOOD PORCH/DECK W/ PIERS  
SCALE: 3/8"=1'-0"

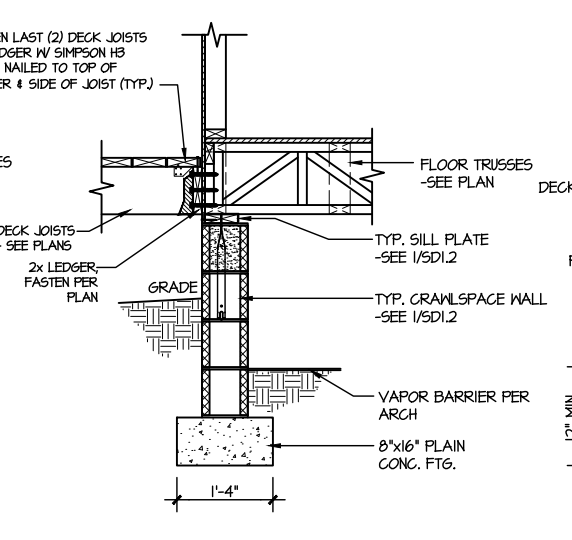

**12** TYPICAL CRAWLSPACE FOUNDATION @ WOOD PORCH/DECK  
SCALE: 3/8"=1'-0"

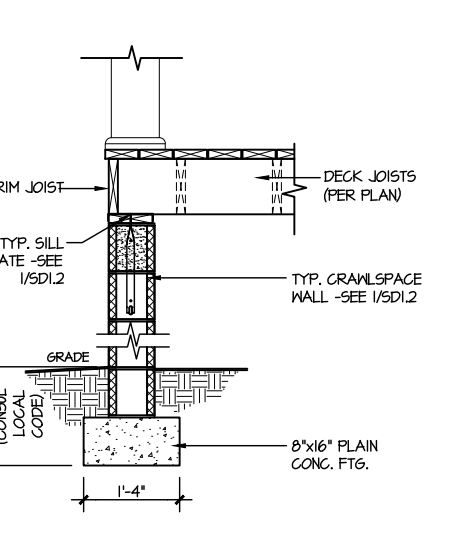

**13** TYPICAL CRAWLSPACE FOUNDATION @ WOOD PORCH/DECK PERIMETER  
SCALE: 3/8"=1'-0"





**MULHERN+KULP**  
RESIDENTIAL STRUCTURAL ENGINEERING  
300 Dunsmuir Ave., Building 4 - Amherst, PA 15802  
P 715-948-8001 - mulhern+kulp.com  
NC LICENSE #C-3825

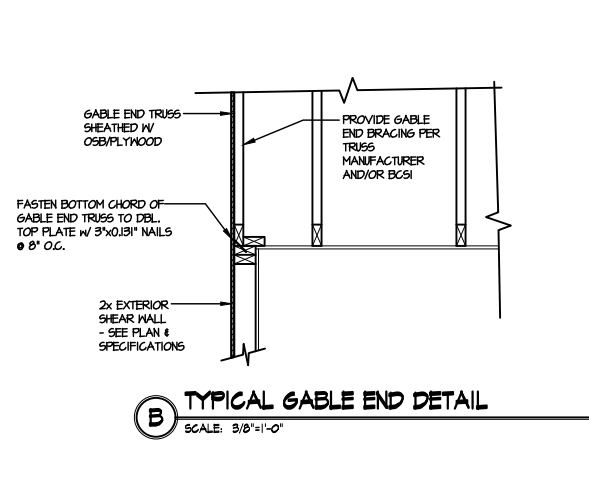
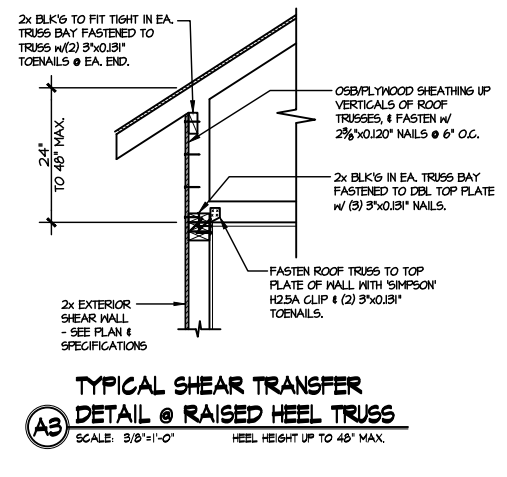
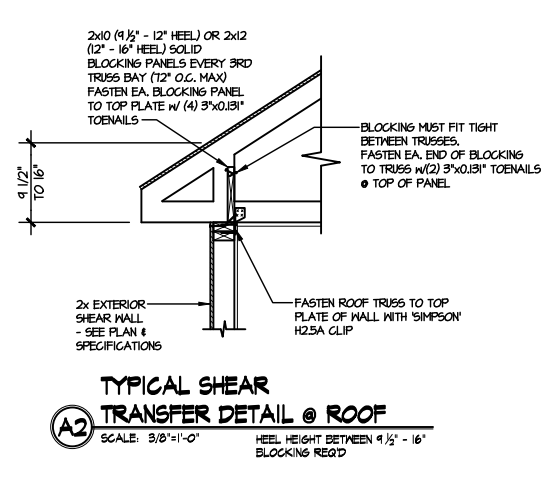
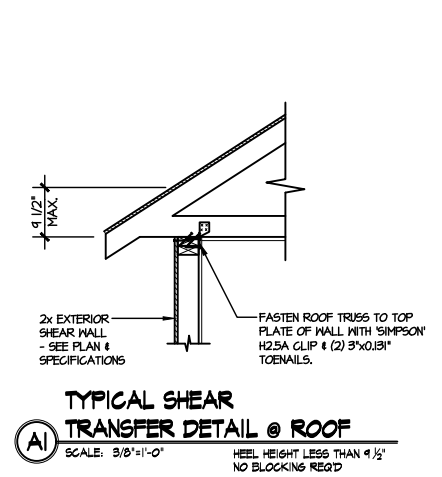

**A1** TYPICAL SHEAR TRANSFER DETAIL @ ROOF  
SCALE: 3/8\"/>

**A2** TYPICAL SHEAR TRANSFER DETAIL @ ROOF  
SCALE: 3/8\"/>

**A3** TYPICAL SHEAR TRANSFER DETAIL @ RAISED HEEL TRUSS  
SCALE: 3/8\"/>

**B** TYPICAL GABLE END DETAIL  
SCALE: 3/8\"/>

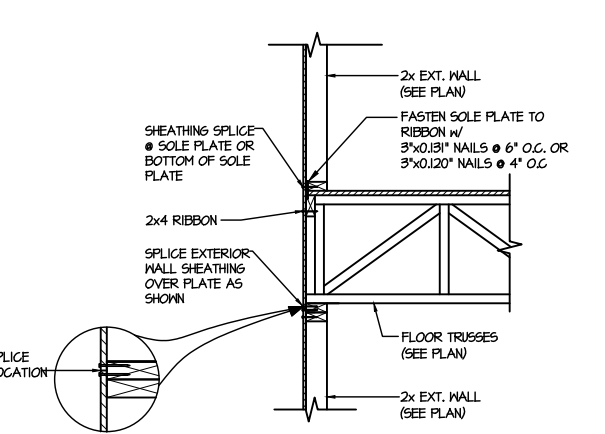
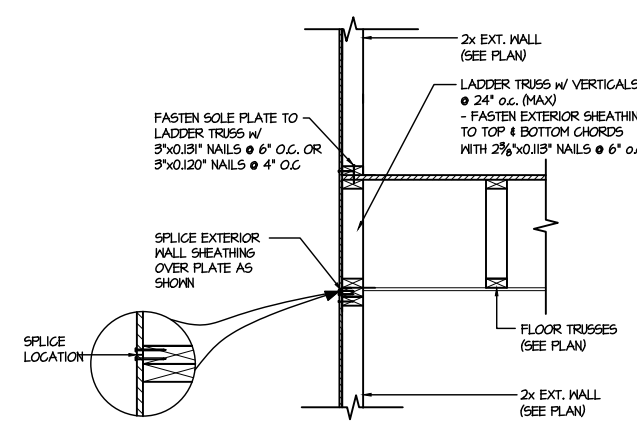

**C1** TYPICAL SHEAR TRANSFER DETAIL BETWEEN FLOORS @ EXTERIOR WALL  
SCALE: 3/8\"/>

**C2** TYPICAL SHEAR TRANSFER DETAIL BETWEEN FLOORS @ EXTERIOR WALL  
SCALE: 3/8\"/>

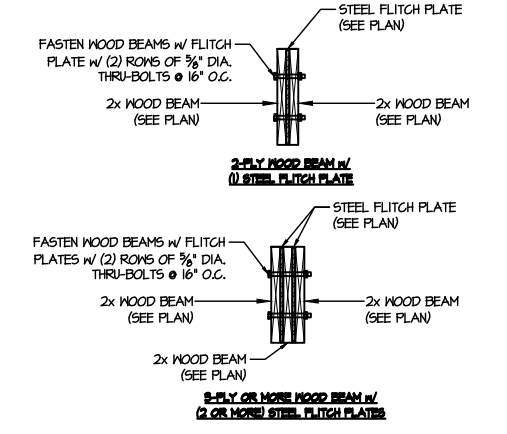

**D** TYPICAL FLITCH BEAM CONNECTION DETAIL  
SCALE: 3/4\"/>

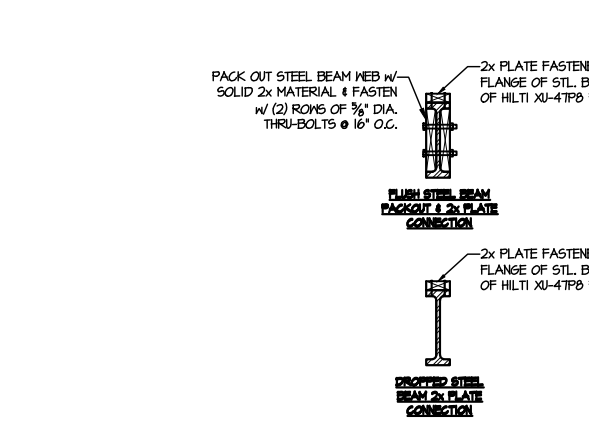

**E** TYPICAL STEEL BEAM CONNECTION DETAIL  
SCALE: 3/4\"/>

M&K project number:  
126-23061  
project mgr: JTR  
drawn by: SJF  
issue date: 01-08-24  
REVISIONS:  
date: initial:  
01-25-24 KFG



FRAMING DETAILS  
BLAKE POND COMMUNITY  
LOT 98 - STONEFIELD 4  
RALEIGH, NC

sheet:  
**SD2.0**

LETTERED DETAILS ARE TYPICAL FOR THIS HOME & SHALL BE IMPLEMENTED IN ALL APPLICABLE AREAS. THESE DETAILS ARE NOT "CUT" ON THE PLANS.  
NUMBERED DETAILS ARE PLAN SPECIFIC AND ARE ONLY REQUIRED WHERE SPECIFICALLY INDICATED ("CUT") ON THE PLANS.

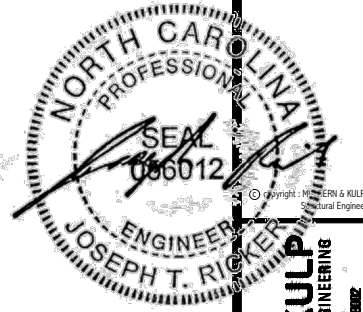

**MULHERN+KULP**  
RESIDENTIAL STRUCTURAL ENGINEERING  
300 Dunsmuir Ave., Building 4 - Annapolis, PA 17822  
P: 717-949-8001 - m.mulhern@mkulpe.com  
NC LICENSE #C-3825



M&K project number:  
126-23061  
project mgr: JTR  
drawn by: SJF  
issue date: 01-08-24

REVISIONS:  
date: 01-25-24 initial: KFG

**DRB HOMES**

FRAMING DETAILS  
BLAKE POND COMMUNITY  
LOT 98 - STONEFIELD 4  
RALEIGH, NC

sheet:  
**SD2.1A**

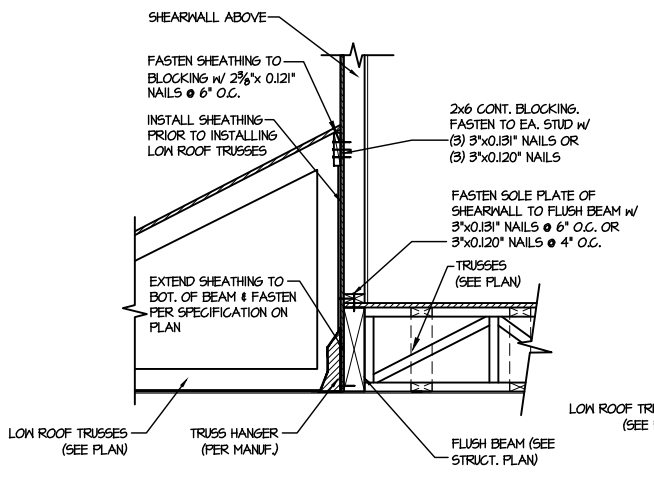

**1 SHEAR TRANSFER DETAIL @ EXTERIOR SHEARWALL ABOVE**  
SCALE: 3/4"=1'-0"

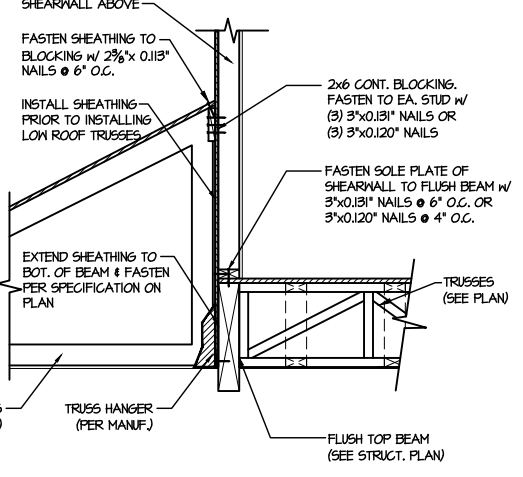

**2 SHEAR TRANSFER DETAIL @ EXTERIOR SHEARWALL ABOVE**  
SCALE: 3/4"=1'-0"

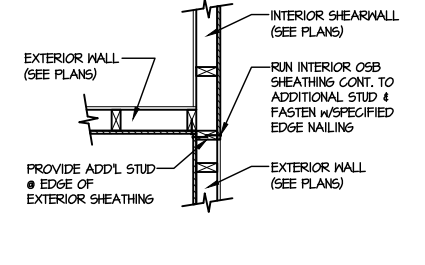

**3 SHEAR TRANSFER DETAIL @ INTERSECTING INT. SHEARWALL**  
SCALE: 3/4"=1'-0" SHTS. OPPOSITE PAGES

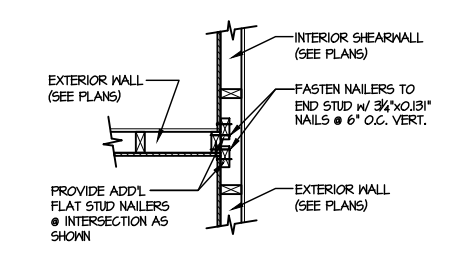

**4 SHEAR TRANSFER DETAIL @ INTERSECTING INT. SHEARWALL**  
SCALE: 3/4"=1'-0" SHTS. ON SAME FACE

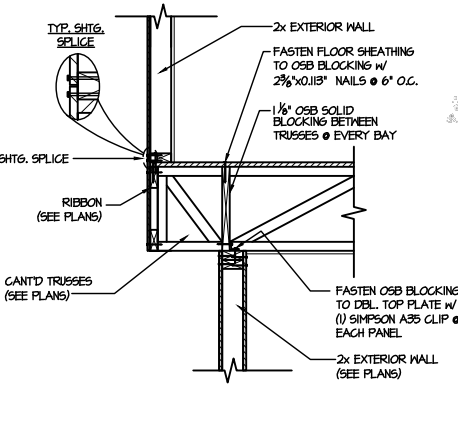

**5 SHEAR TRANSFER DETAIL BETWEEN FLOORS @ CANT'D EXT. WALL**  
SCALE: 3/4"=1'-0" PERPENDICULAR FRAMING

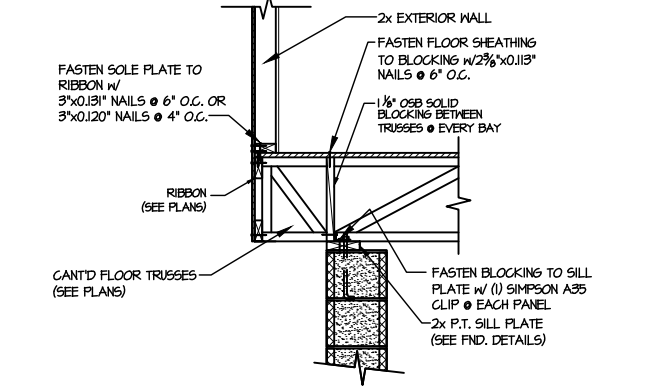

**6 SHEAR TRANSFER DETAIL @ CANT'D EXTERIOR WALL**  
SCALE: 3/4"=1'-0"

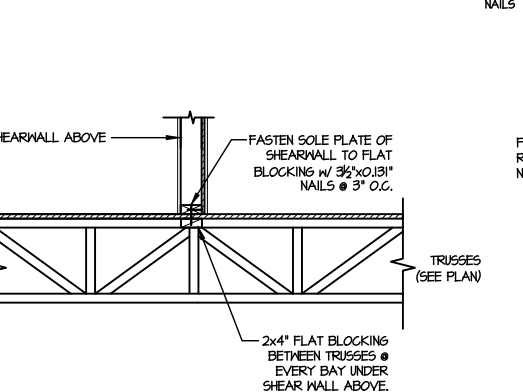

**7 SHEAR TRANSFER DETAIL @ INTERIOR SHEARWALL ABOVE**  
SCALE: 3/4"=1'-0" PERPENDICULAR FRAMING

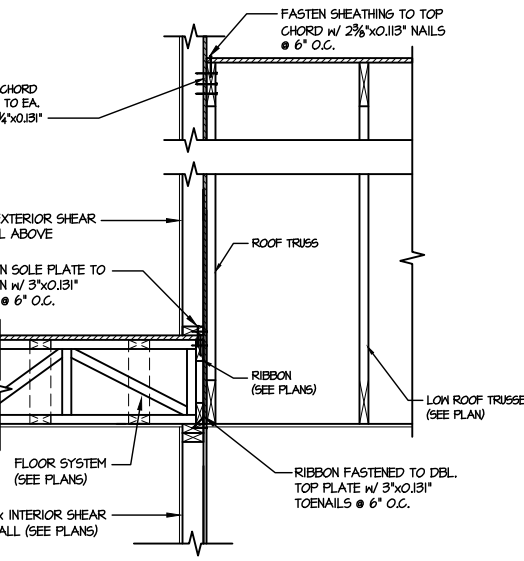

**8 TYPICAL SHEAR TRANSFER DETAIL BETWEEN FLOORS @ INTERIOR WALL**  
SCALE: 3/4"=1'-0"

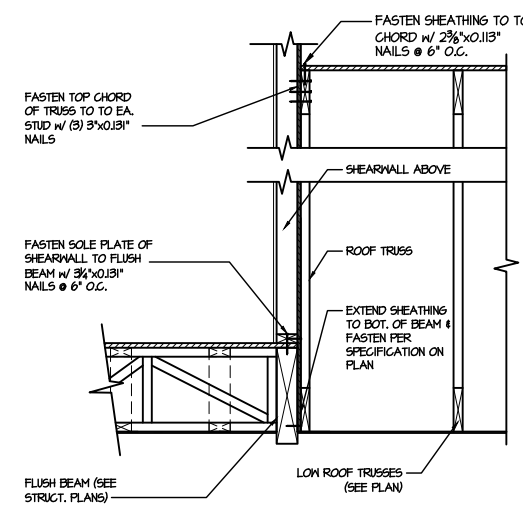

**9 SHEAR TRANSFER DETAIL @ EXTERIOR SHEARWALL ABOVE**  
SCALE: 3/4"=1'-0"

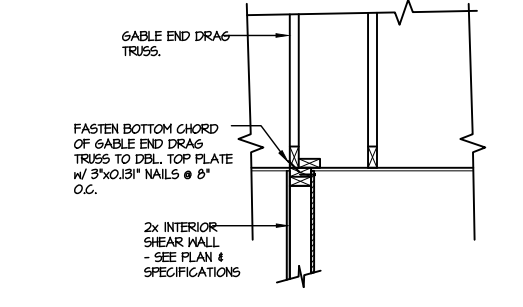

**10 INTERIOR GABLE END DETAIL**  
SCALE: 3/4"=1'-0"

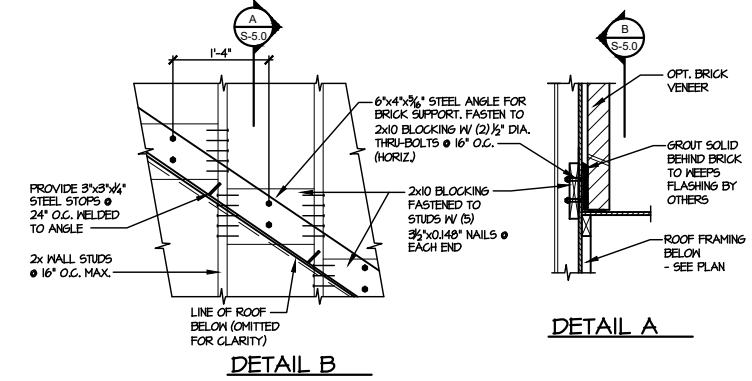

**11 DETAIL SUPPORT OF BRICK VENEER**  
SCALE: 3/4"=1'-0"

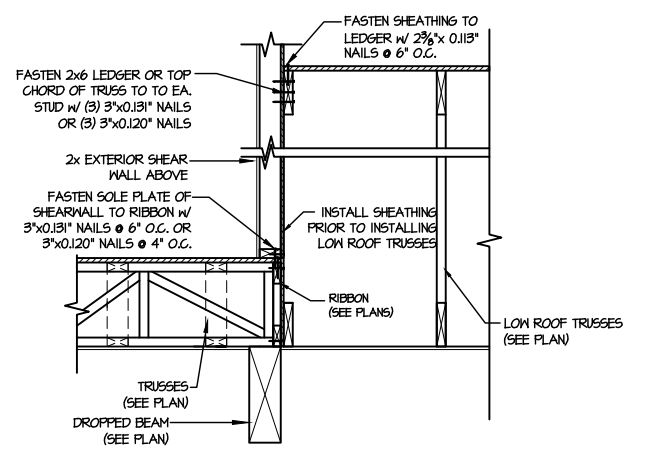

**12 TYPICAL SHEAR TRANSFER DETAIL BETWEEN FLOORS @ INTERIOR WALL**  
SCALE: 3/4"=1'-0"

FILE: RLH - Blake Pond - Lot 98 - Structural DATE: 1/26/2024 2:06 PM

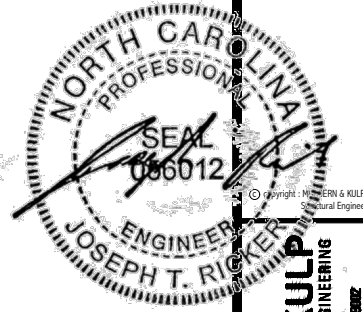

**MULHERN+KULP**  
RESIDENTIAL STRUCTURAL ENGINEERING  
300 Bannockburn Ave., Building 4 - Annapolis, PA 18602  
P: 715-698-0001 • mulhern+kulp.com  
NC LICENSE #C-3825

M&K project number:  
126-23061  
project mgr: JTR  
drawn by: SJF  
issue date: 01-08-24

REVISIONS:  
date: initial:  
01-25-24 KFG

**DRB HOMES**

FRAMING DETAILS  
BLAKE POND COMMUNITY  
LOT 98 - STONEFIELD 4  
RALEIGH, NC

sheet:  
**SD2.1B**

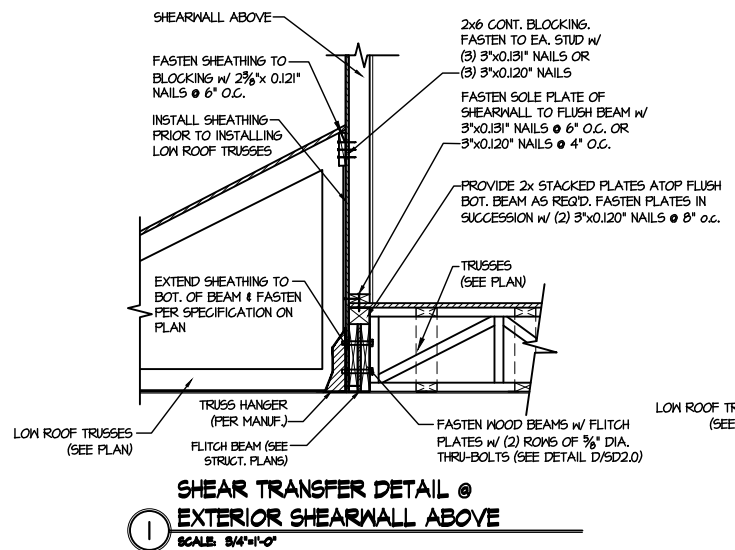

**1** SHEAR TRANSFER DETAIL @ EXTERIOR SHEARWALL ABOVE  
SCALE: 3/4"=1'-0"

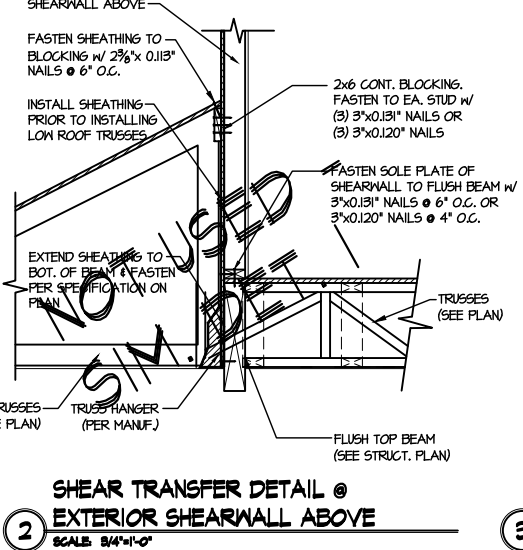

**2** SHEAR TRANSFER DETAIL @ EXTERIOR SHEARWALL ABOVE  
SCALE: 3/4"=1'-0"

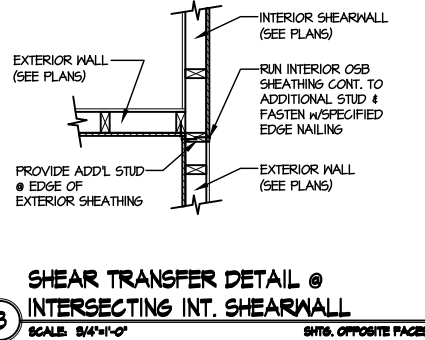

**3** SHEAR TRANSFER DETAIL @ INTERSECTING INT. SHEARWALL  
SCALE: 3/4"=1'-0" SHTS. OPPOSITE FACES

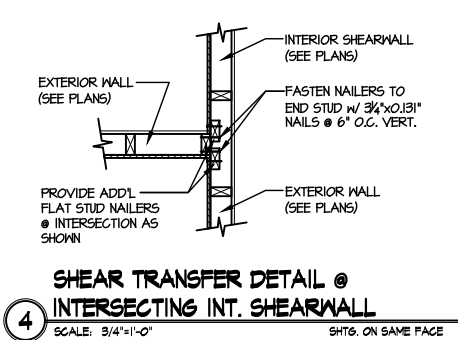

**4** SHEAR TRANSFER DETAIL @ INTERSECTING INT. SHEARWALL  
SCALE: 3/4"=1'-0" SHTS. ON SAME FACE

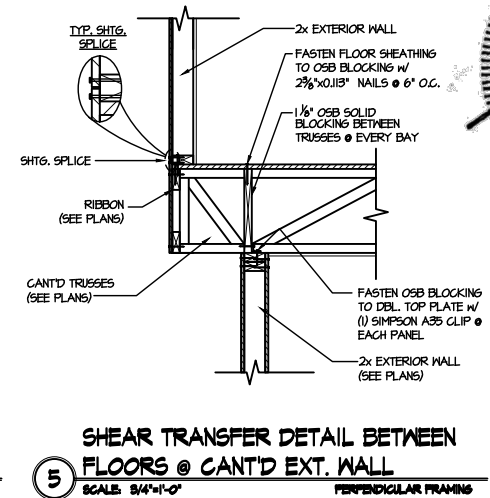

**5** SHEAR TRANSFER DETAIL BETWEEN FLOORS @ CANT'D EXT. WALL  
SCALE: 3/4"=1'-0" PERPENDICULAR FRAMING

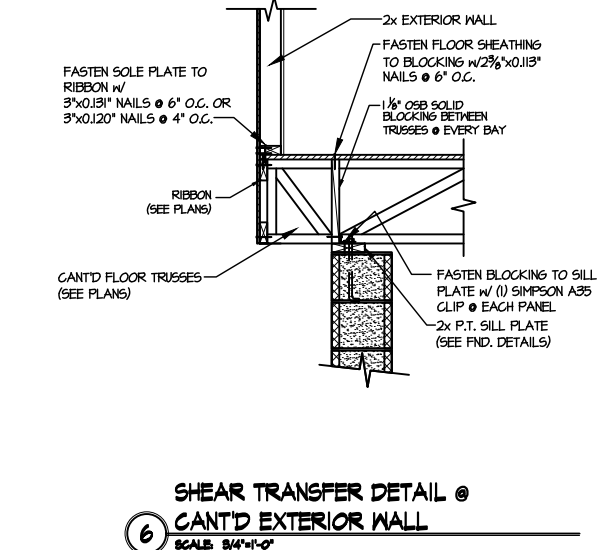

**6** SHEAR TRANSFER DETAIL @ CANT'D EXTERIOR WALL  
SCALE: 3/4"=1'-0"

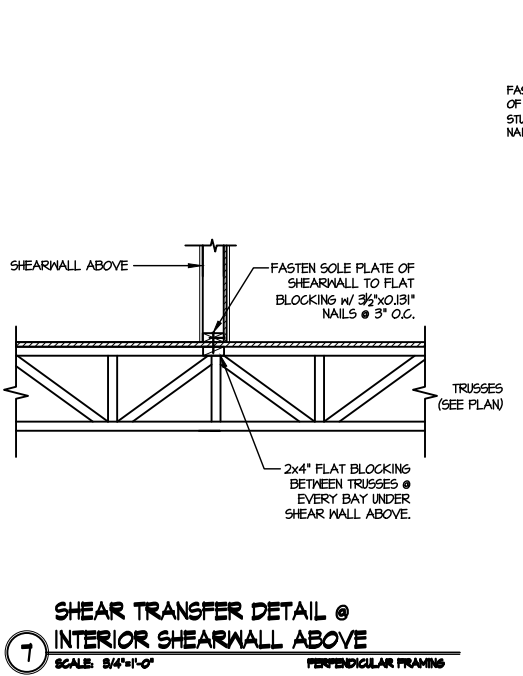

**7** SHEAR TRANSFER DETAIL @ INTERIOR SHEARWALL ABOVE  
SCALE: 3/4"=1'-0" PERPENDICULAR FRAMING

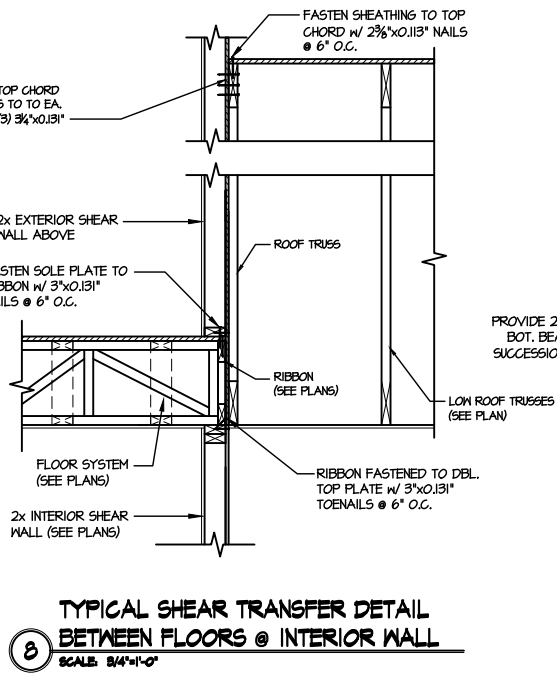

**8** TYPICAL SHEAR TRANSFER DETAIL BETWEEN FLOORS @ INTERIOR WALL  
SCALE: 3/4"=1'-0"

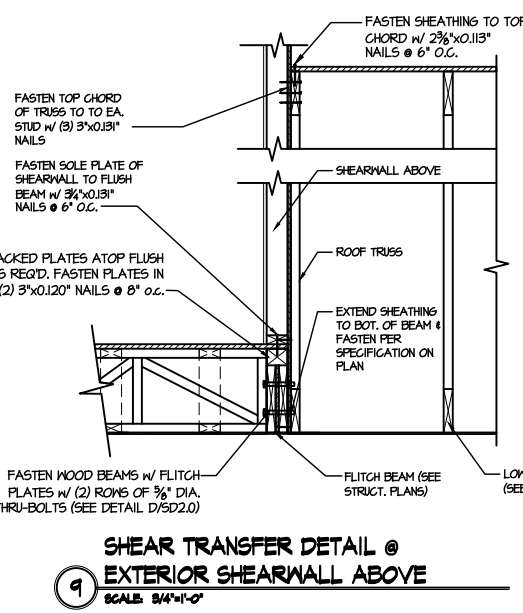

**9** SHEAR TRANSFER DETAIL @ EXTERIOR SHEARWALL ABOVE  
SCALE: 3/4"=1'-0"

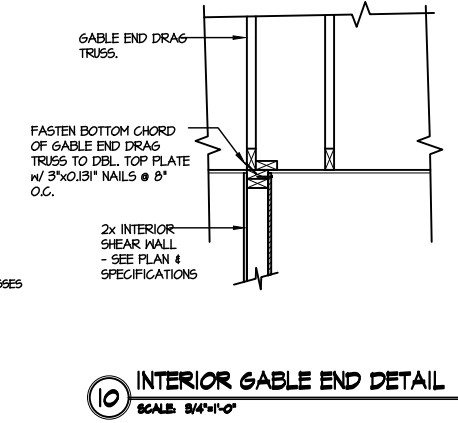

**10** INTERIOR GABLE END DETAIL  
SCALE: 3/4"=1'-0"

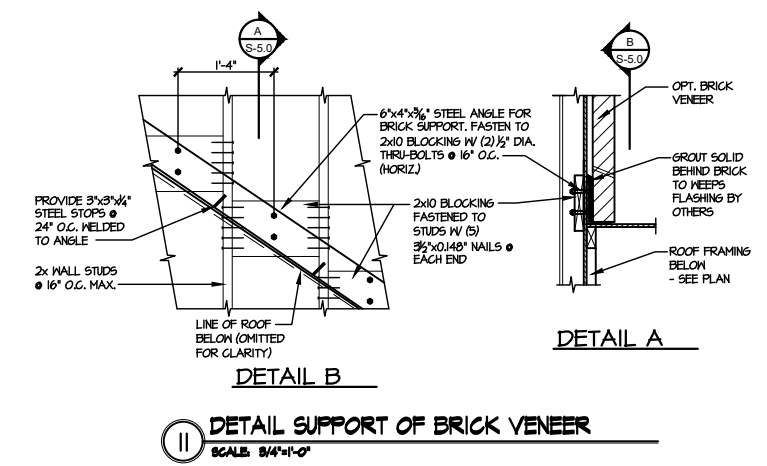

**11** DETAIL SUPPORT OF BRICK VENEER  
SCALE: 3/4"=1'-0"

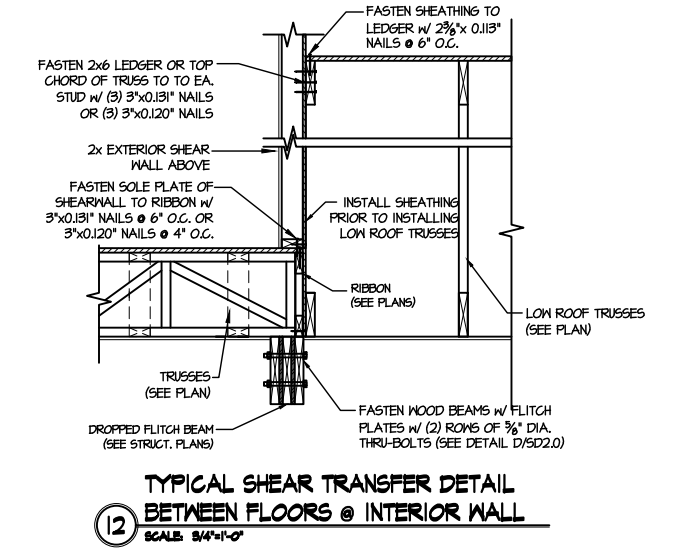

**12** TYPICAL SHEAR TRANSFER DETAIL BETWEEN FLOORS @ INTERIOR WALL  
SCALE: 3/4"=1'-0"

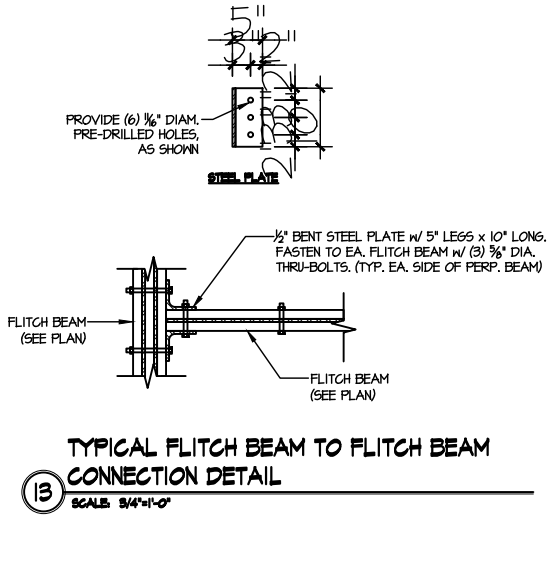

**13** TYPICAL FLITCH BEAM TO FLITCH BEAM CONNECTION  
SCALE: 3/4"=1'-0"

FILE: RLH - Blake Pond - Lot 98 - Structural DATE: 1/26/2024 2:06 PM



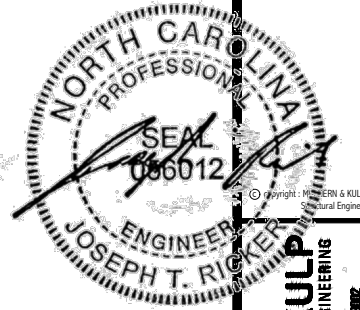

MULHERN+KULP  
RESIDENTIAL STRUCTURAL ENGINEERING  
310 Riverside Ave., Building 4 - Asheville, PA 15802  
P: 215-948-0001 - mulhern+kulp.com  
NC LICENSE HC-3825

M&K project number:  
126-23061  
project mgr: JTR  
drawn by: SJF  
issue date: 01-08-24

REVISIONS:  
date: initial:  
01-25-24 KFG

DRB HOMES

FRAMING DETAILS  
BLAKE POND COMMUNITY  
LOT 98 - STONEFIELD 4  
RALEIGH, NC

sheet:  
SD2.1C

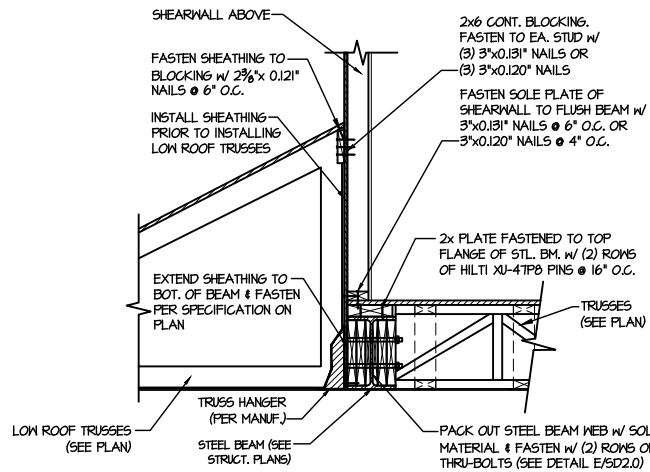

1 SHEAR TRANSFER DETAIL @ EXTERIOR SHEARWALL ABOVE  
SCALE: 3/4"=1'-0"

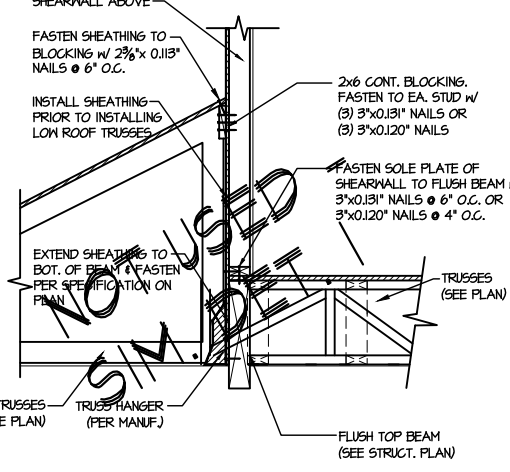

2 SHEAR TRANSFER DETAIL @ EXTERIOR SHEARWALL ABOVE  
SCALE: 3/4"=1'-0"

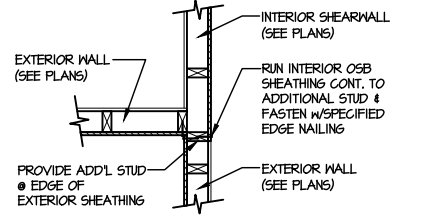

3 SHEAR TRANSFER DETAIL @ INTERSECTING INT. SHEARWALL  
SCALE: 3/4"=1'-0" SHTS. OPPOSITE FACES

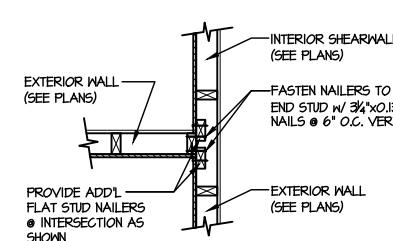

4 SHEAR TRANSFER DETAIL @ INTERSECTING INT. SHEARWALL  
SCALE: 3/4"=1'-0" SHTS. ON SAME FACE

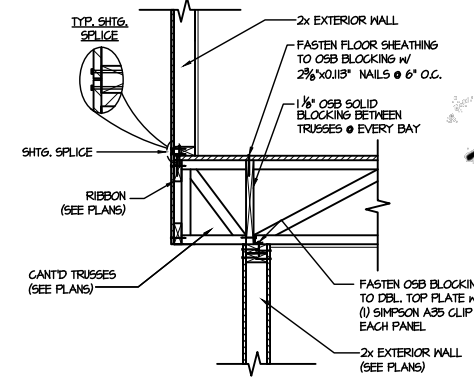

5 SHEAR TRANSFER DETAIL BETWEEN FLOORS @ CANT'D EXT. WALL  
SCALE: 3/4"=1'-0" PERPENDICULAR FRAMING

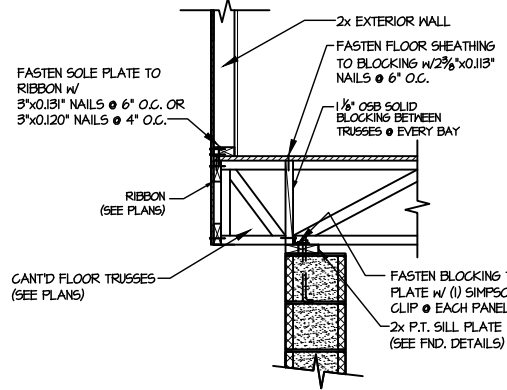

6 SHEAR TRANSFER DETAIL @ CANT'D EXTERIOR WALL  
SCALE: 3/4"=1'-0"

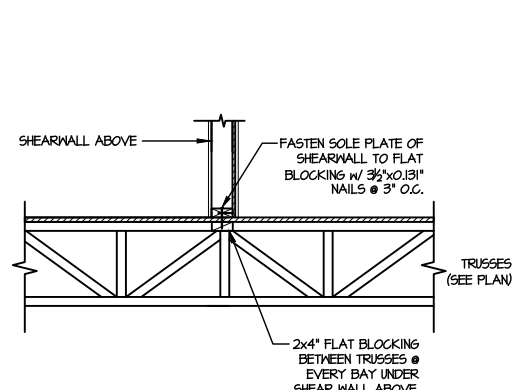

7 SHEAR TRANSFER DETAIL @ INTERIOR SHEARWALL ABOVE  
SCALE: 3/4"=1'-0" PERPENDICULAR FRAMING

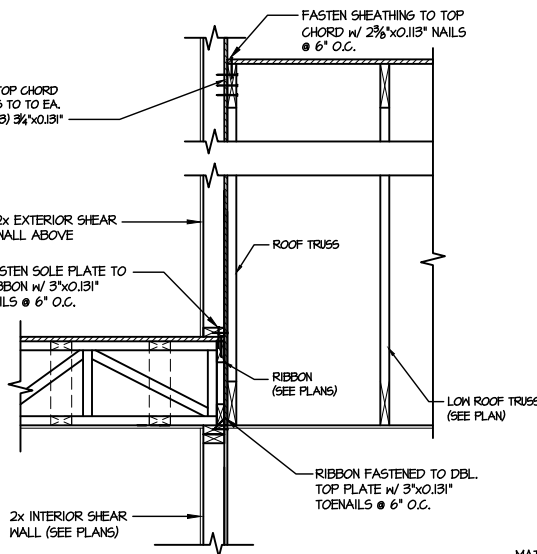

8 TYPICAL SHEAR TRANSFER DETAIL BETWEEN FLOORS @ INTERIOR WALL  
SCALE: 3/4"=1'-0"

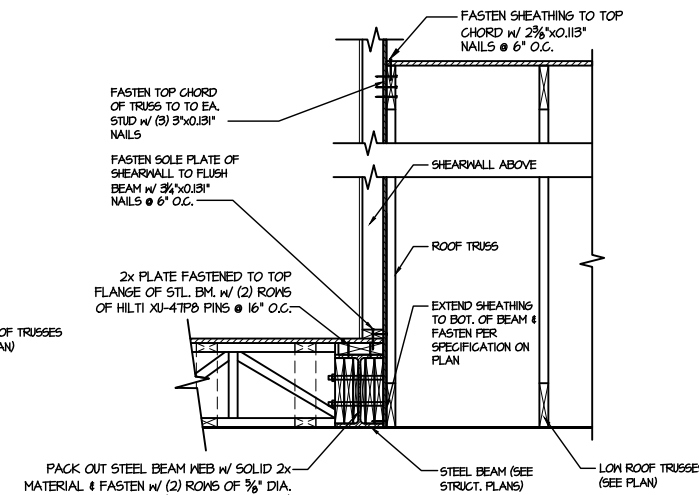

9 SHEAR TRANSFER DETAIL @ EXTERIOR SHEARWALL ABOVE  
SCALE: 3/4"=1'-0"

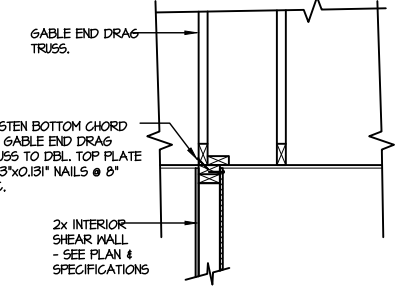

10 INTERIOR GABLE END DETAIL  
SCALE: 3/4"=1'-0"

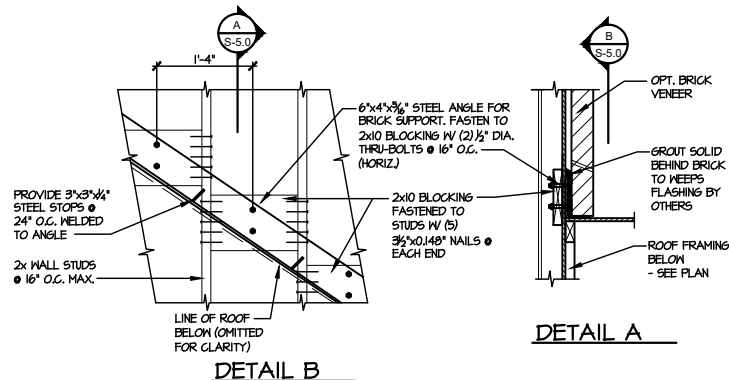

11 DETAIL SUPPORT OF BRICK VENEER  
SCALE: 3/4"=1'-0"

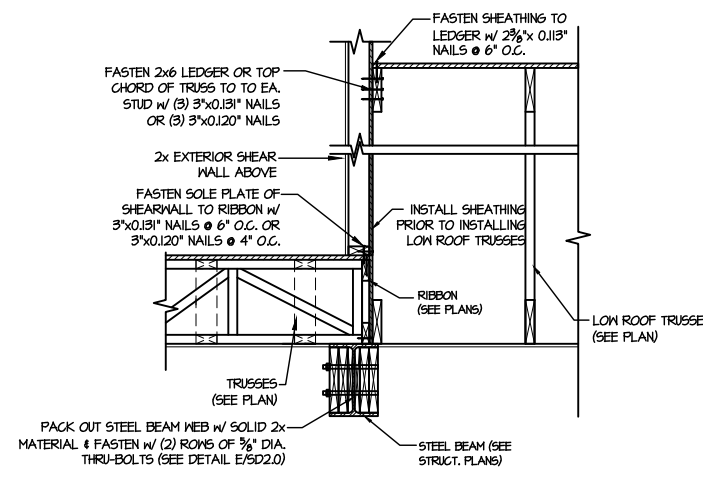

12 TYPICAL SHEAR TRANSFER DETAIL BETWEEN FLOORS @ INTERIOR WALL  
SCALE: 3/4"=1'-0"

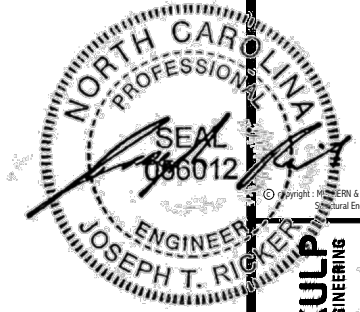

**MULHERN+KULP**  
RESIDENTIAL STRUCTURAL ENGINEERING  
310 Rembrandt Ave., Building 4 - Asheville, PA 15802  
P 215-948-8001 - mulhern+kulp.com  
NC LICENSE #C-3825



M&K project number:  
126-23061  
project mgr: JTR  
drawn by: SJF  
issue date: 01-08-24  
REVISIONS:  
date: initial:  
01-25-24 KFG

**DRB HOMES**

FRAMING DETAILS  
BLAKE POND COMMUNITY  
LOT 98 - STONEFIELD 4  
RALEIGH, NC

sheet:  
**SD2.2**

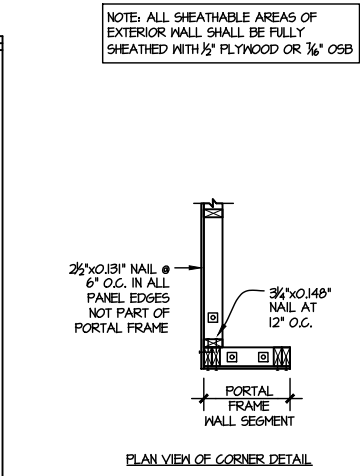
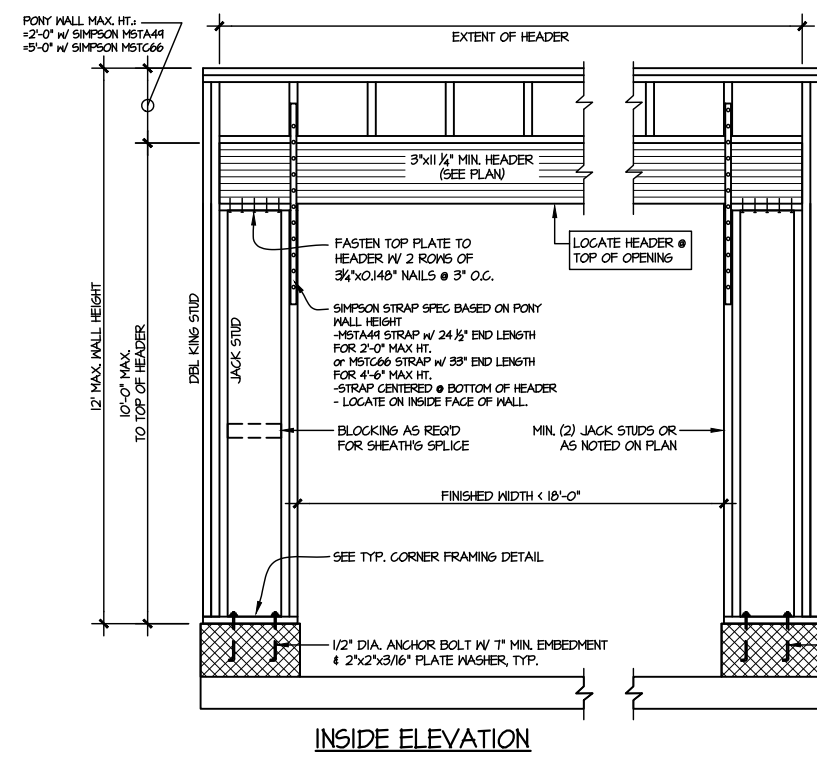
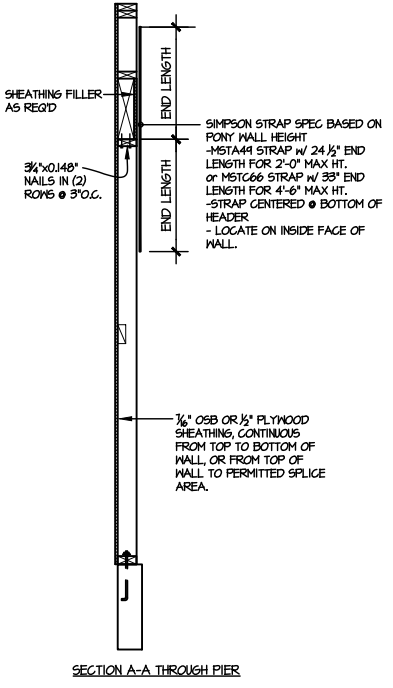
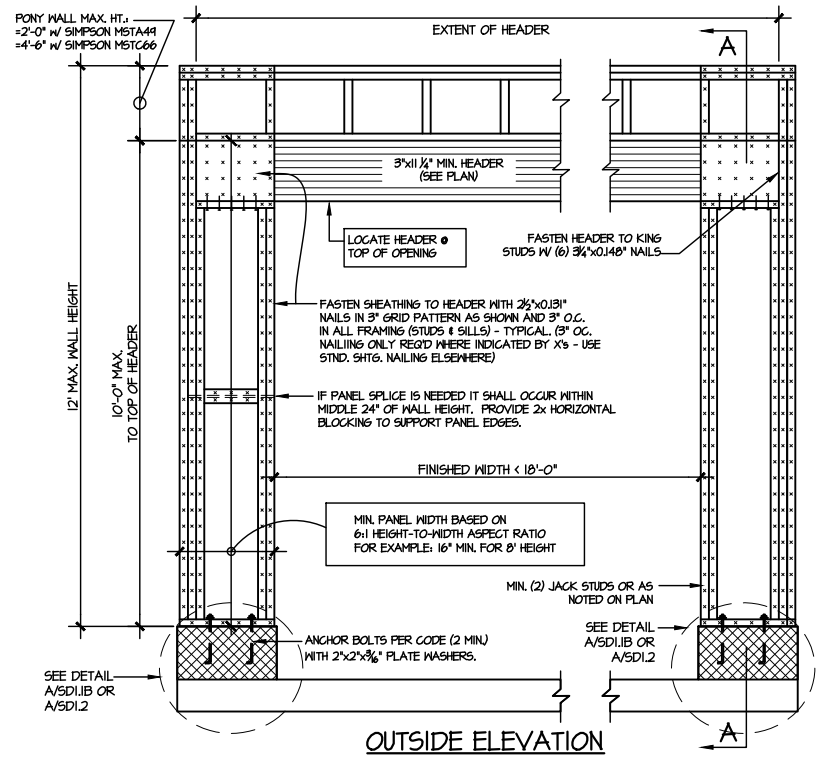

ALTERNATIVE TO 1/2" DIA. ANCHOR BOLT:  
1) 1/2" DIA. THREADED ROD EPOXY SET W/ 4 1/2" EMBED. (MIN) UTILIZING HILTI HY200 EPOXY ANCHORING SYSTEM (OR EQUAL)

**2** TWO SIDED GARAGE PORTAL FRAME BRACING ELEVATION ON CMU STEM  
SCALE: N.T.S.

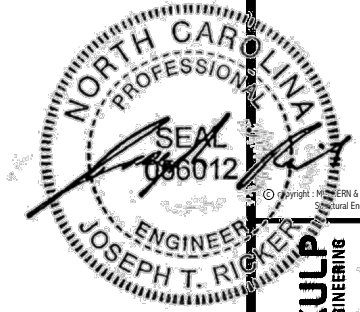

**MULHERN+KULP**  
RESIDENTIAL STRUCTURAL ENGINEERING  
303 Dunsmuir Ave, Building 4 - Anshutz, PA 15022  
P 715-948-8001 - mulhern+kulp.com  
NC LICENSE #C-3825

M&K project number:  
126-23061  
project mgr: JTR  
drawn by: SJF  
issue date: 01-08-24

REVISIONS:  
date: initial:  
01-25-24 KFG



FRAMING DETAILS  
BLAKE POND COMMUNITY  
LOT 98 - STONEFIELD 4  
RALEIGH, NC

sheet:  
**SD3.0**

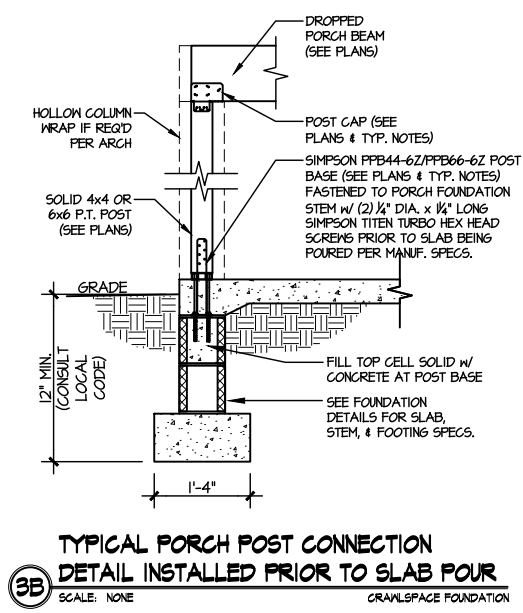
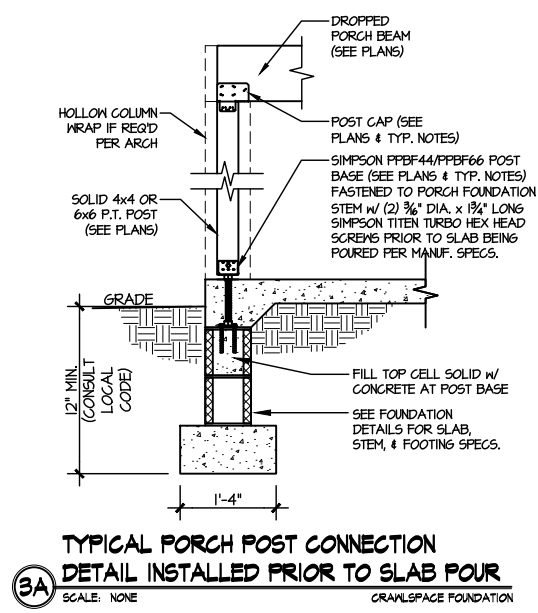
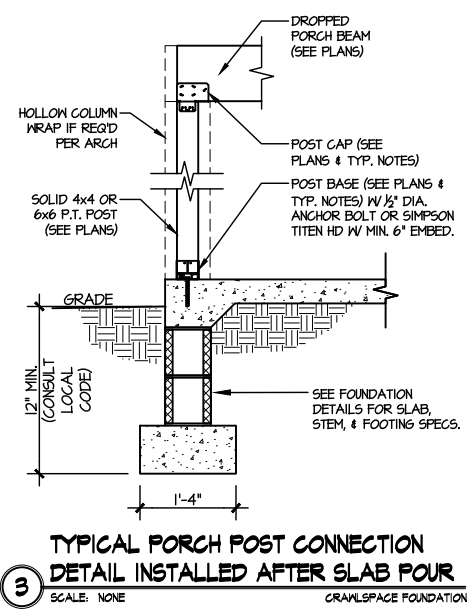

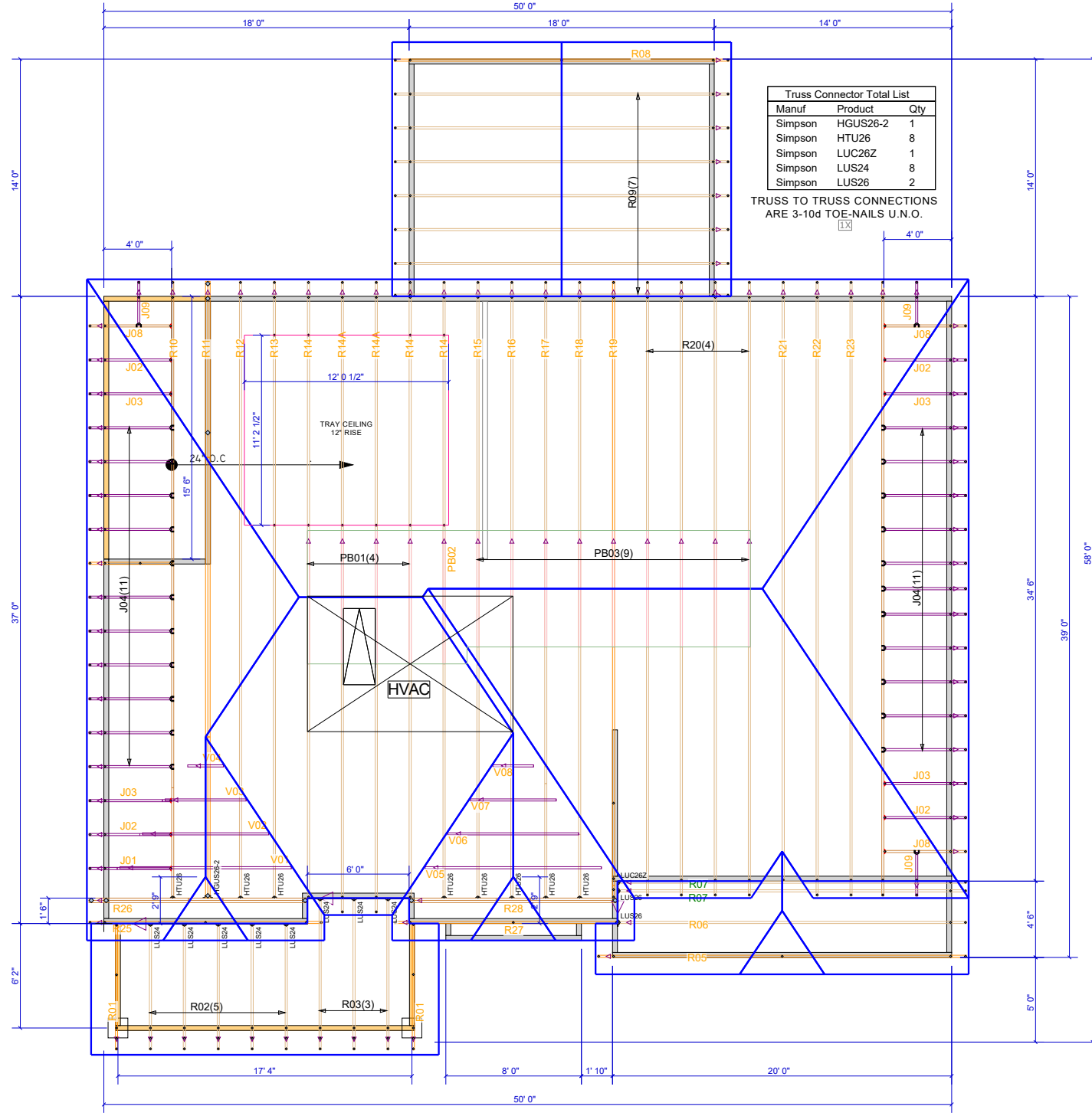

**FOR PERMIT**

Client: DRB GROUP-RALEIGH  
 Job: LOT 0.0098 BLAKE POND

Plan Information:  
**STONEFIELD-4**  
 EXT. KIT W/ OWNER SUITE

Revisions:



1998 Cane Gully Road, Moncks Corner SC 29461  
 Phone: (800) 475-3999 Fax (843) 565-3193  
 Web: www.atlanticbcs.com

**ROOF**

NOT TO SCALE  
 Drawn By: CGT  
 Date: 6/9/2017  
 Job #: 123-B587-R01  
 Sales Rep: KYLE GIBSON  
 Phone: 843-729-3249



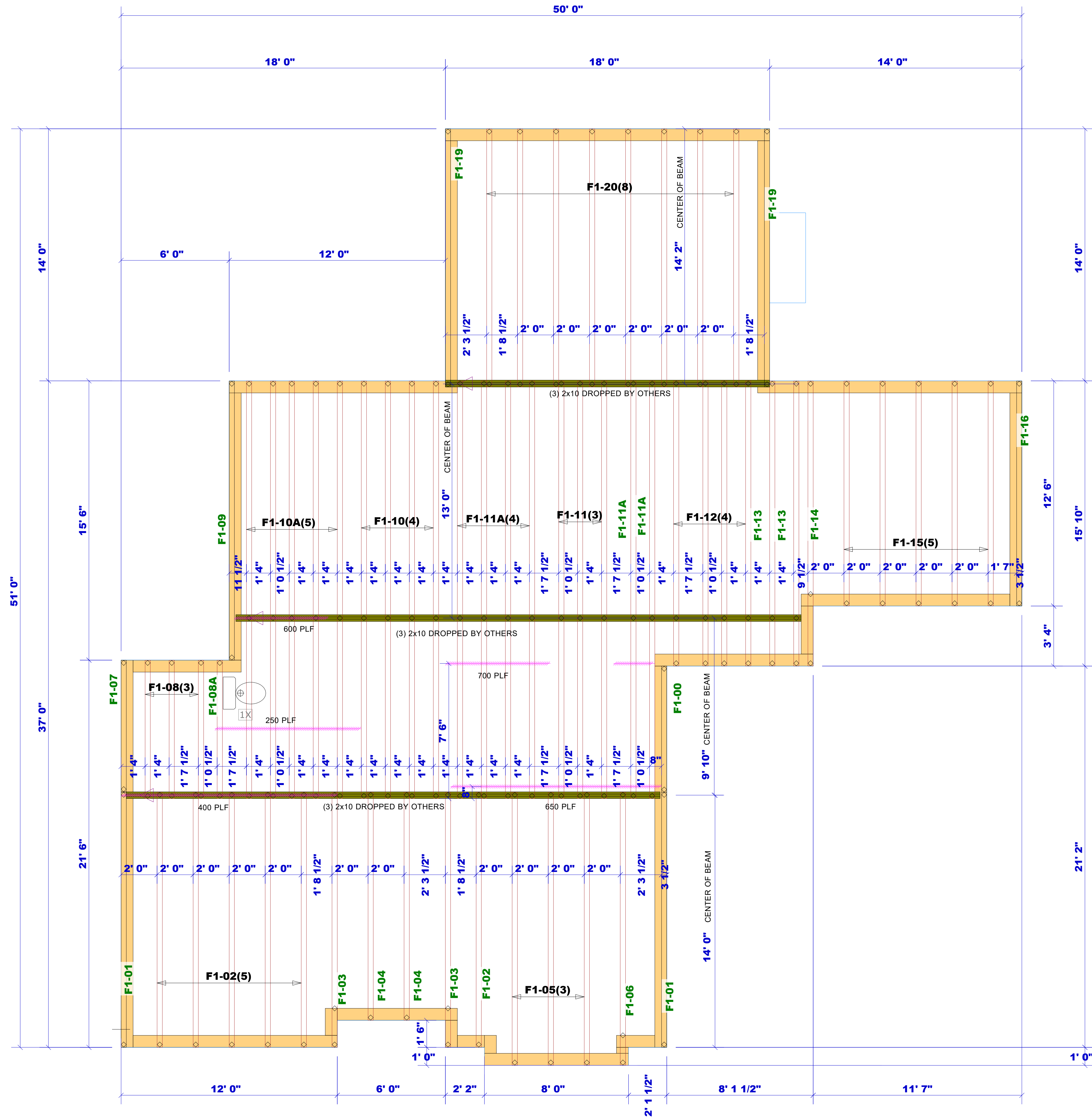

▲ = LEFT END OF TRUSS

FOR PERMIT

Client: DRB GROUP-RALEIGH	
Job: LOT 0.0098 BLAKE POND	
Plan Information: STONEFIELD-4	
NOT TO SCALE	Date: 12/21/23
Drawn By: ANS	Job #: Sales Rep: KYLE GIBSON
	Phone: 864-304-3282

REVISIONS:



Moncks Corner/Easley, SC (800) 475-3999  
Sparta, NC (336) 372-2226

**WARNING!** Long span trusses, 60' or greater in length, require extreme care and experience for proper and safe handling and installation. For general handling and installation guidance, see the "Guide to Good Practice for Handling, Installing, Restraining & Bracing of Metal Plate Connected Wood Trusses ("BCSI"), JOINTLY PRODUCED BY SBCA and TPI. For project specific guidance, consult with a registered design professional. ATLANTIC assumes no responsibility for the handling, installation or bracing of trusses.

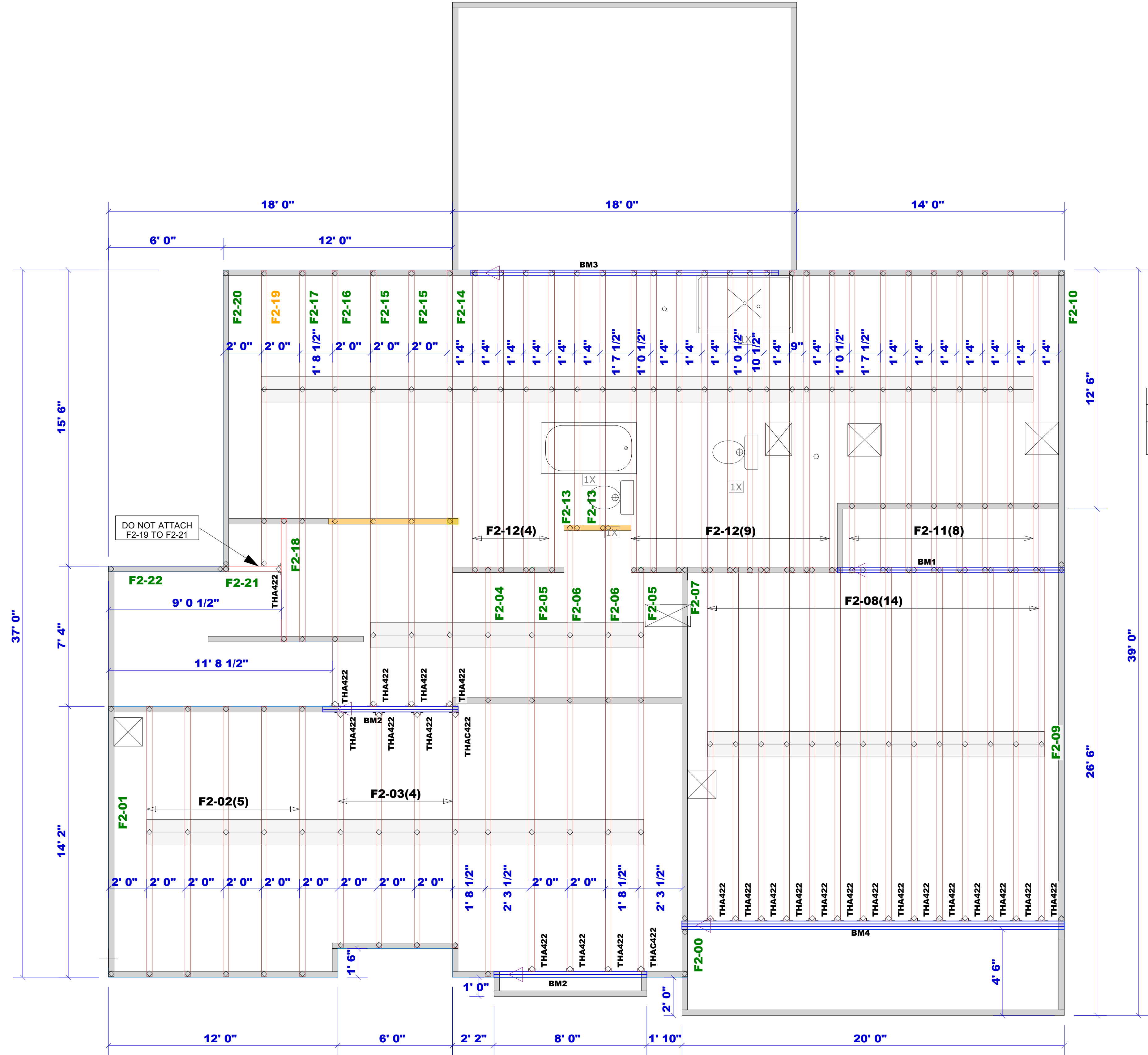

Truss Connector Total List		
Manuf	Product	Qty
Simpson	THA422	25
Simpson	THAC422	2

Products					
PlotID	Length	Product	Plies	Net Qty	Fab Type
BM1	12' 0"	1-3/4" x 11-7/8" VERSA-LAM® 2.0 3100 SP	2	2	MFD
BM2	8' 0"	1-3/4" x 14" VERSA-LAM® 2.0 3100 SP	2	4	MFD
BM3	17' 0"	1-3/4" x 16" VERSA-LAM® 2.0 3100 SP	2	2	MFD
BM4	20' 0"	1-3/4" x 18" VERSA-LAM® 2.0 3100 SP	3	3	MFD

**FOR PERMIT**

Client: **DRB GROUP-RALEIGH**  
 Job: **LOT 0.0098 BLAKE POND**  
 Plan Information: **STONEFIELD-4**

NOT TO SCALE  
 Drawn By: ANS  
 Date: 1-11-17  
 Job #: Sales Rep: KYLE GIBSON  
 23-B587-F02 Phone: 843-729-3249



1998 Cane Gully Road, Moncks Corner SC 29461  
 Phone: (800) 475-3999 Fax (843) 565-3193  
 Web: www.atlanticbcs.com