

LOT INFORMATION:
 PIN: 0642-94-3968.000
 REFERENCE: DB, 4084 PGS. 320-324
 TOTAL LOT AREA = 0.980 AC = 42,692 SF
 FOUNDATION = 2,122 SF
 EXISTING IMPERVIOUS = 2,122 SF
 PERCENT IMPERVIOUS = 4.97%
 MAXIMUM ALLOWED IMPERVIOUS = 4,000 SF

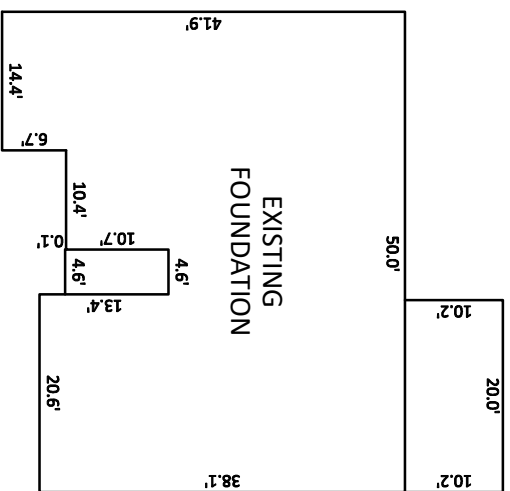

INSET SCALE: 1"=20'

- NOTES:**
1. THIS SURVEY WAS PREPARED BY BATEMAN CIVIL SURVEY CO., UNDER THE SUPERVISION OF STEVEN P. CARSON, PLS.
 2. THIS PLAN HAS BEEN PREPARED FOR LAYOUT AND PERMITTING PURPOSES ONLY. PROPERTY LINES SHOWN WERE TAKEN FROM EXISTING FIELD EVIDENCE, EXISTING DEEDS AND/OR PLATS OF PUBLIC RECORD, AND INFORMATION SUPPLIED TO THE SURVEYOR BY THE CLIENT.
 3. ALL DISTANCES ARE HORIZONTAL GROUND DISTANCES AND ALL BEARINGS ARE NORTH CAROLINA STATE PLANE COORDINATE SYSTEM UNLESS OTHERWISE SHOWN. THIS MAP IS NOT FOR RECORDATION AND SHOULD BE REVIEWED BY A LOCAL GOVERNMENT AGENCY FOR COMPLIANCE WITH ANY APPLICABLE LAND DEVELOPMENT REGULATIONS.
 4. THE BASIS OF NORTH AND ALL EASEMENTS, RIGHTS-OF-WAYS, BUFFERS, SETBACKS AND ADJOINERS, ETC. REFERENCED IN TITLE BLOCK.
 5. NO INVESTIGATION INTO THE EXISTENCE OF JURISDICTIONAL WETLANDS OR RIPARIAN BUFFERS PERFORMED BY THIS FIRM.
 6. SURVEYOR HAS MADE NO INVESTIGATION OR INDEPENDENT SEARCH FOR EASEMENTS OF RECORD, ENCUMBRANCES, RESTRICTIVE COVENANTS, OWNERSHIP TITLE EVIDENCE OR ANY OTHER FACTS THAT AN ACCURATE AND CURRENT TITLE SEARCH MAY DISCLOSE.
 7. **THE PROPERTY LIES IN ZONE 'X' PER NATIONAL FLOOD INSURANCE PROGRAM F.I.R.M. MAP #37200642001, DATED OCTOBER 03 2006.**
 8. ZONING IS : RA-40
 9. A 5' PUBLIC UTILITY EASEMENT LIES PARALLEL TO THE ROADWAY RIGHT OF WAY ALONG EACH SIDE, EXCEPT OPEN SPACE 4.
 10. PROPERTY OWNER: KB HOME RALEIGH- DURHAM INC.
4506 S. MIAMI BLVD. #100
DURHAM, NC. 27703

CURVE TABLE				
CURVE	RADIUS	LENGTH	CHORD DIRECTION	CHORD
C1	475.00'	59.40'	N52°59'52"W	59.36'
C2	475.00'	77.79'	N61°16'19"W	77.70'
C3	475.00'	136.65'	N74°12'19"W	136.18'

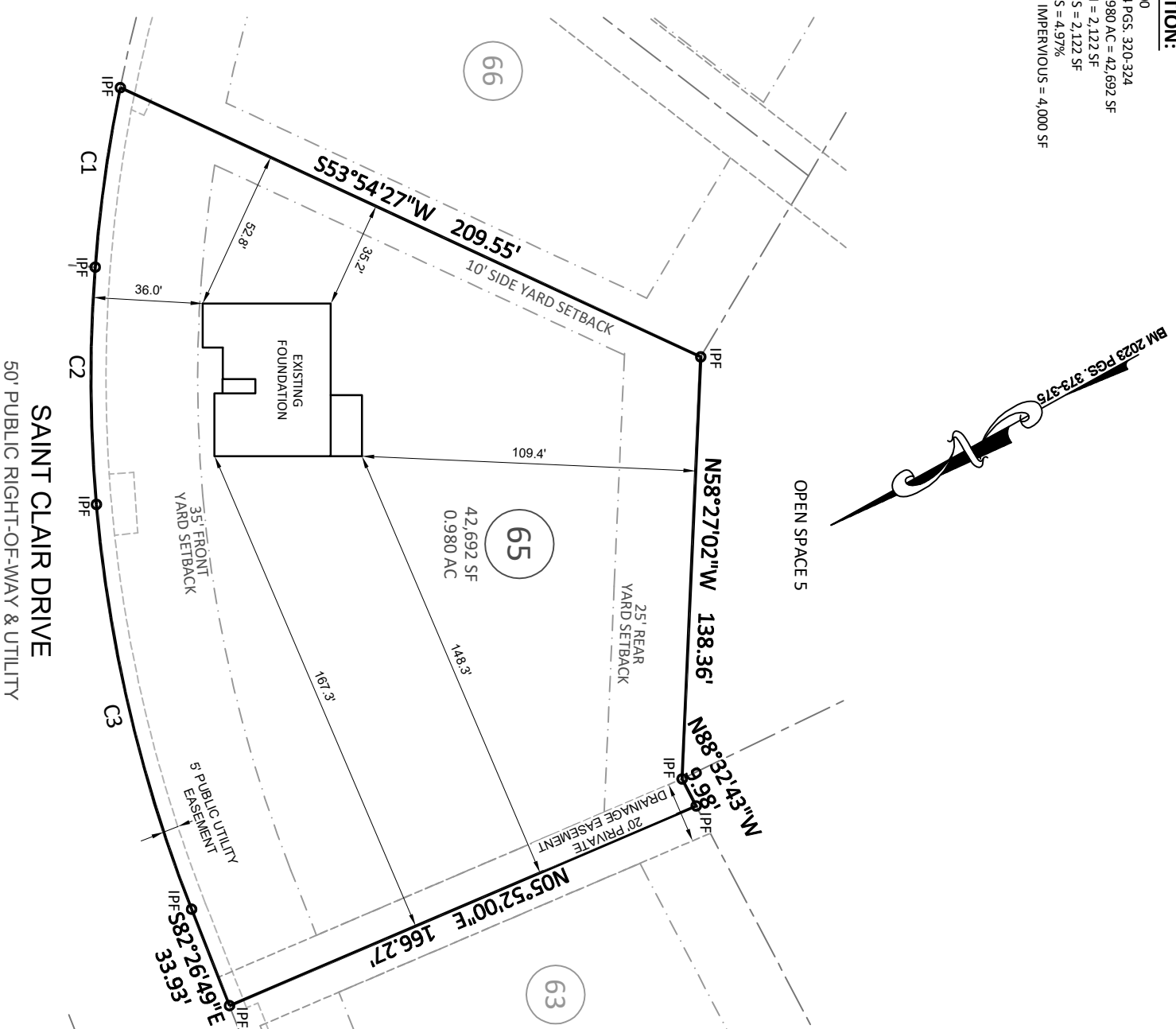

Bateman Civil Survey Company
 Engineers • Surveyors • Planners
 2524 Reliance Avenue, Apex, NC 27539 Ph: 919.577.1080 Fax: 919.577.1081
 www.batemancivilsurvey.com info@batemancivilsurvey.com
 NCBELS Firm No. C-2378

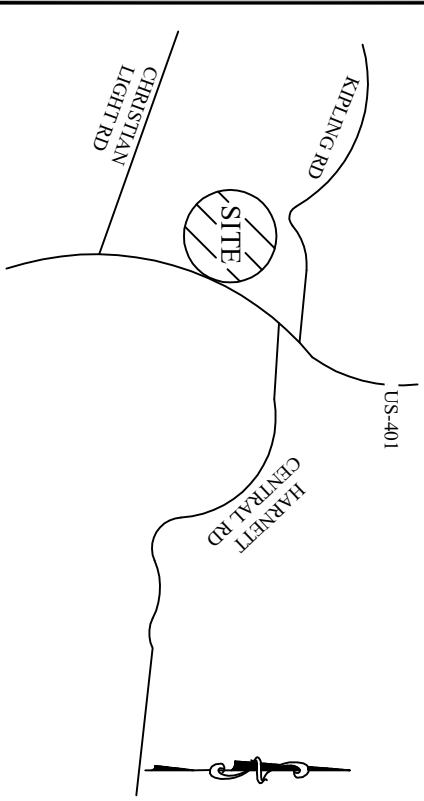

VICINITY MAP
 (Not to Scale)

LEGEND
 PO = PORCH
 P = PATIO
 SP = SCREENED PORCH OR PATIO
 CP = COVERED PORCH OR PATIO
 WD = WOOD DECK
 SW = SIDEWALK
 DW = CONC DRIVEWAY
 CP = COMPUTED POINT (IPF)
 IP = IRON PIPE SET (IPS)
 WM = WATER METER
 CO = CLEANOUT
 AC = AIR CONDITIONER
 EB = ELECTRIC BOX
 CB = CABLE BOX
 TP = TELEPHONE PEDESTAL
 LP = LIGHT POLE
 CI = CURB INLET
 YI = YARD INLET
 FH = FIRE HYDRANT
 HP = HANDICAP PORTAJOHN WITH SCREENING
 SM = SEWER MANHOLE
 FH = FIRE HYDRANT
 TR = TRASH RECEPTACLES

BUILDING SETBACKS:
 FRONT = 35 ft
 SIDE = 10 ft
 REAR = 25 ft
 CORNER SIDE = 20 ft

This map is of an existing parcel of land and is only intended for the parties and purposes shown. This map not for recordation. No title report provided.

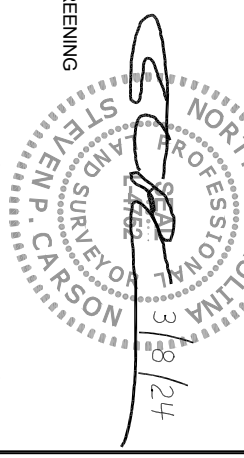

FOUNDATION SURVEY

FOR
KB HOME

BIRCHWOOD GROVE - PHASE 2 - LOT 65
 403 SAINT CLAIR DRIVE, FUQUAY-VARINA, NC
 HECTOR'S CREEK TOWNSHIP, HARNETT COUNTY
 DATE: 3/8/24 DRAWN BY: ALT CHECKED BY: SPC
 REFERENCE: BM 2023 PGS. 373-375 PROJECT# 220207 SCALE: 1"=50'