

**PLANS DESIGNED TO THE  
2018 NORTH CAROLINA STATE  
RESIDENTIAL BUILDING CODE**

MEAN ROOF HEIGHT: 18'-4" HEIGHT TO RIDGE: 24'-8"

CLIMATE ZONE	ZONE 3A	ZONE 4A	ZONE 5A
FENESTRATION U-FACTOR	0.35	0.35	0.35
SKYLIGHT U-FACTOR	0.55	0.55	0.55
GLAZED FENESTRATION SHGC	0.30	0.30	0.30
CEILING R-VALUE	38 or 30ci	38 or 30ci	38 or 30ci
WALL R-VALUE	15	15	19
FLOOR R-VALUE	19	19	30
* BASEMENT WALL R-VALUE	5/13	10/15	10/15
** SLAB R-VALUE	0	10	10
* CRAWL SPACE WALL R-VALUE	5/13	10/15	10/19

\*10/13" MEANS R-10 SHEATHING INSULATION OR R-13 CAVITY INSULATION  
\*\* INSULATION DEPTH WITH MONOLITHIC SLAB 24" OR FROM INSPECTION GAP TO BOTTOM OF FOOTING; INSULATION DEPTH WITH STEM WALL SLAB 24" OR TO BOTTOM OF FOUNDATION WALL  
DESIGNED FOR WIND SPEED OF 120 MPH, 3 SECOND GUST (93 FASTEST MILE) EXPOSURE "B"

COMPONENT & CLADDING DESIGNED FOR THE FOLLOWING LOADS

MEAN ROOF	UP TO 30'	30'-1" TO 35'	35'-1" TO 40'	40'-1" TO 45'
ZONE 1	14.2	-15.0	14.9	-15.8
ZONE 2	14.2	-18.0	14.9	-18.9
ZONE 3	14.2	-18.0	14.9	-18.9
ZONE 4	15.5	-16.0	16.3	-16.8
ZONE 5	15.5	-20.0	16.3	-21.0

DESIGNED FOR WIND SPEED OF 130 MPH, 3 SECOND GUST (101 FASTEST MILE) EXPOSURE "B"

COMPONENT & CLADDING DESIGNED FOR THE FOLLOWING LOADS

MEAN ROOF	UP TO 30'	30'-1" TO 35'	35'-1" TO 40'	40'-1" TO 45'
ZONE 1	16.7	-18.0	17.5	-18.9
ZONE 2	16.7	-21.0	17.5	-22.1
ZONE 3	16.7	-21.0	17.5	-22.1
ZONE 4	18.2	-19.0	19.1	-20.0
ZONE 5	18.2	-24.0	19.1	-25.2

**ROOF VENTILATION**

**SECTION R806**  
**R806.1 Ventilation required.** Enclosed attics and enclosed rafter spaces formed where ceilings are applied directly to the underside of roof rafters shall have cross ventilation for each separate space by ventilating openings protected against the entrance of rain or snow. Ventilation openings shall have a least dimension of 1/16 inch (1.6 mm) minimum and 1/4 inch (6.4 mm) maximum. Ventilation openings having a least dimension larger than 1/4 inch (6.4 mm) shall be provided with corrosion-resistant wire cloth screening, hardware cloth, or similar material with openings having a least dimension of 1/16 inch (1.6 mm) minimum and 1/4 inch (6.4 mm) maximum. Openings in roof framing members shall conform to the requirements of Section R802.7.

**R806.2 Minimum area.** The total net free ventilating area shall not be less than 1/150 of the area of the space ventilated except that reduction of the total area to 1/300 is permitted provided that at least 50 percent and not more than 80 percent of the required ventilating area is provided by ventilators located in the upper portion of the space to be ventilated at least 3 feet (914 mm) above the eave or cornice vents with the balance of the required ventilation provided by eave or cornice vents. As an alternative, the net free cross-ventilation area may be reduced to 1/300 when a Class I or II vapor retarder is installed on the warm-in-winter side of the ceiling.

- Exceptions:**
1. Enclosed attic/rafter spaces requiring less than 1 square foot (0.0929 m2) of ventilation may be vented with continuous soffit ventilation only.
  2. Enclosed attic/rafter spaces over unconditioned space may be vented with continuous soffit vent only.

SQUARE FOOTAGE OF ROOF TO BE VENTED = 2,192 SQ.FT.  
NET FREE CROSS VENTILATION NEEDED:  
WITHOUT 50% TO 80% OF VENTING 3'-0" ABOVE EAVE = 14.61 SQ.FT.  
WITH 50% TO 80% OF VENTING 3'-0" ABOVE EAVE; OR WITH CLASS I OR II VAPOR RETARDER ON WARM-IN-WINTER SIDE OF CEILING = 7.31 SQ.FT.

**AIR LEAKAGE**

**Section N1102.4**  
**N1102.4.1 Building thermal envelope.** The building thermal envelope shall be durably sealed with an air barrier system to limit infiltration. The sealing methods between dissimilar materials shall allow for differential expansion and contraction. For all homes, where present, the following shall be caulked, gasketed, weather stripped or otherwise sealed with an air barrier material or solid material consistent with Appendix E-2.4 of this code:

1. Blocking and sealing floor/ceiling systems and under knee walls open to unconditioned or exterior space.
2. Capping and sealing shafts or chases, including flue shafts.
3. Capping and sealing soffit or dropped ceiling areas.



**WEST PRESERVE - LOT 31 3CG  
143 OLEANDER LN. SANFORD, NC 27332**

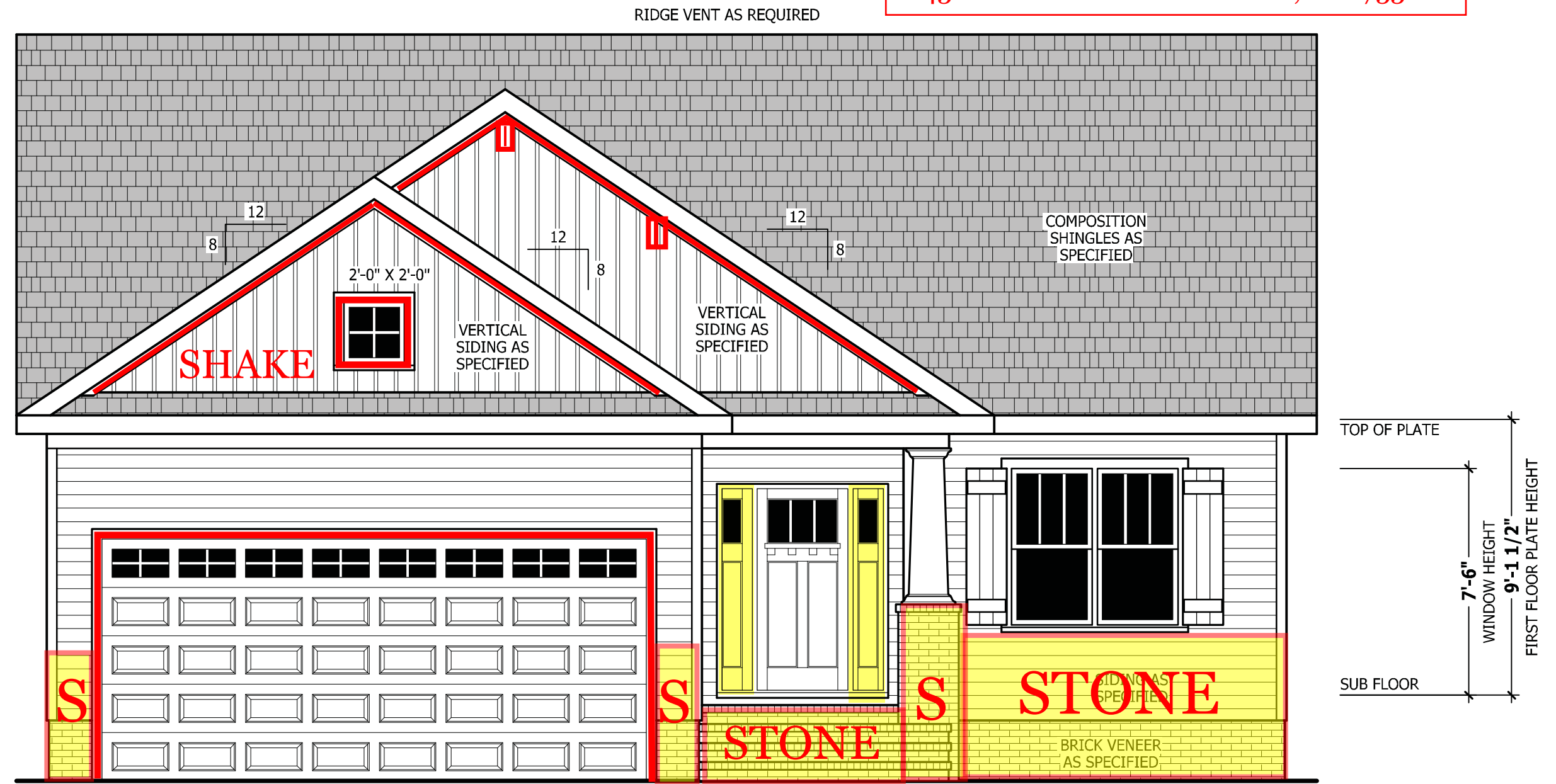

**FRONT ELEVATION - B**  
SCALE 1/4" = 1'-0"



**FRONT - B WITH SIDE LOAD**  
SCALE 1/8" = 1'-0"

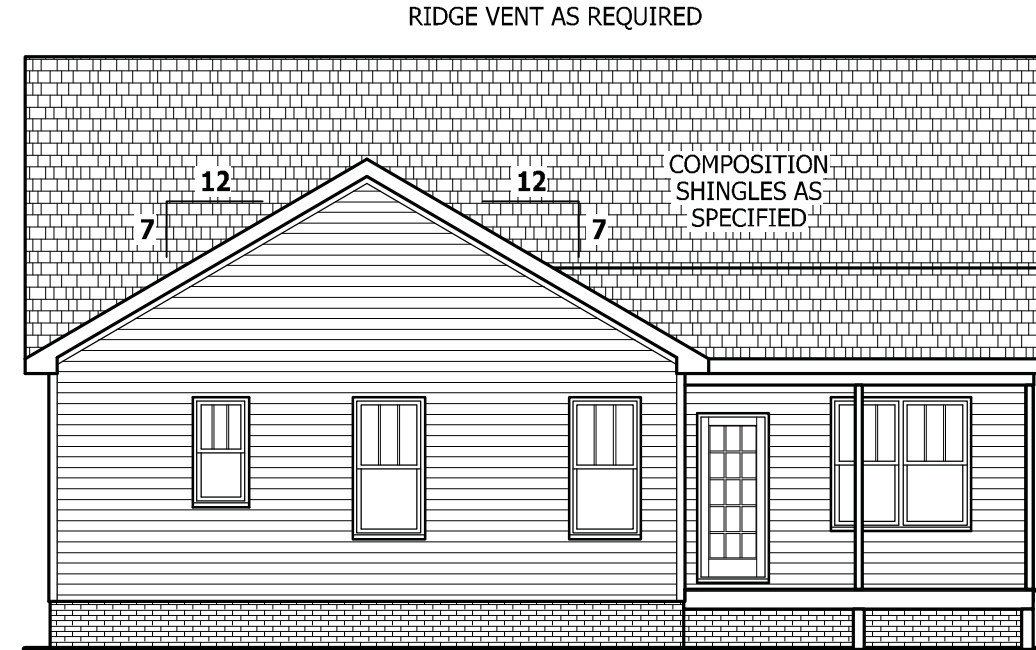

**REAR ELEVATION**  
SCALE 1/8" = 1'-0"

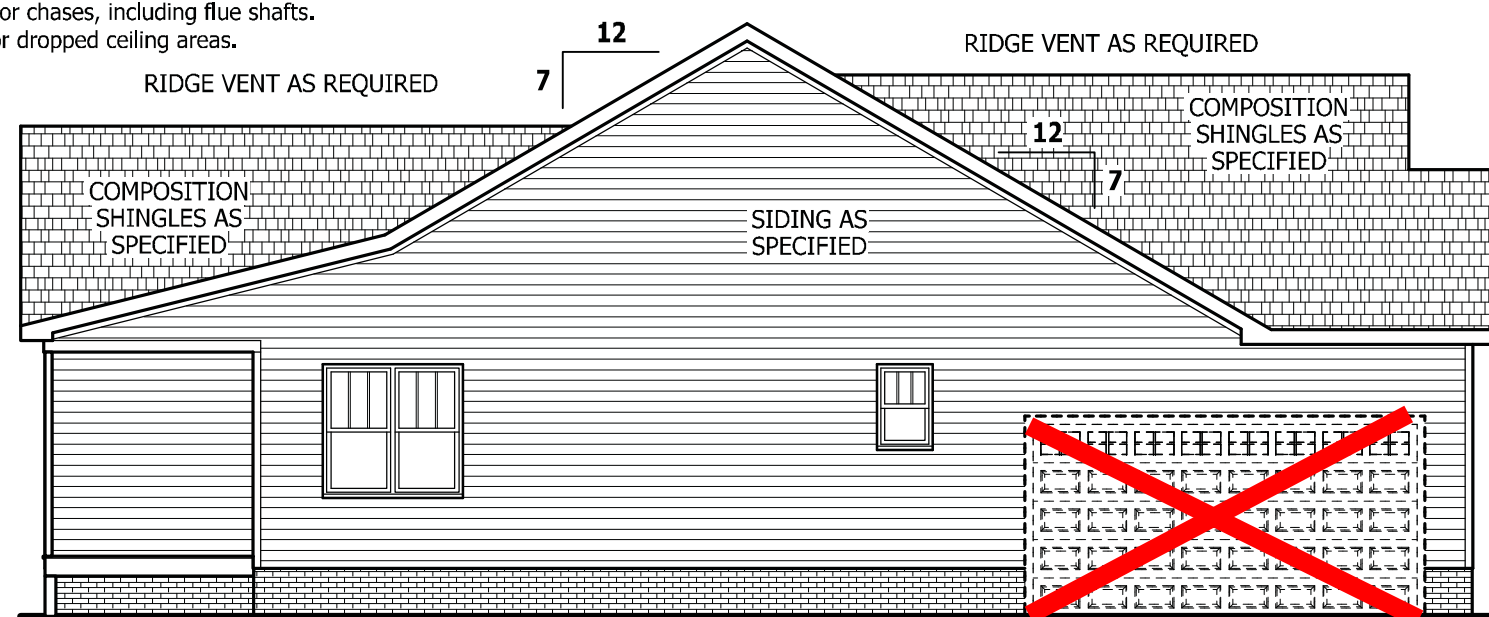

**LEFT SIDE ELEVATION**  
SCALE 1/8" = 1'-0"

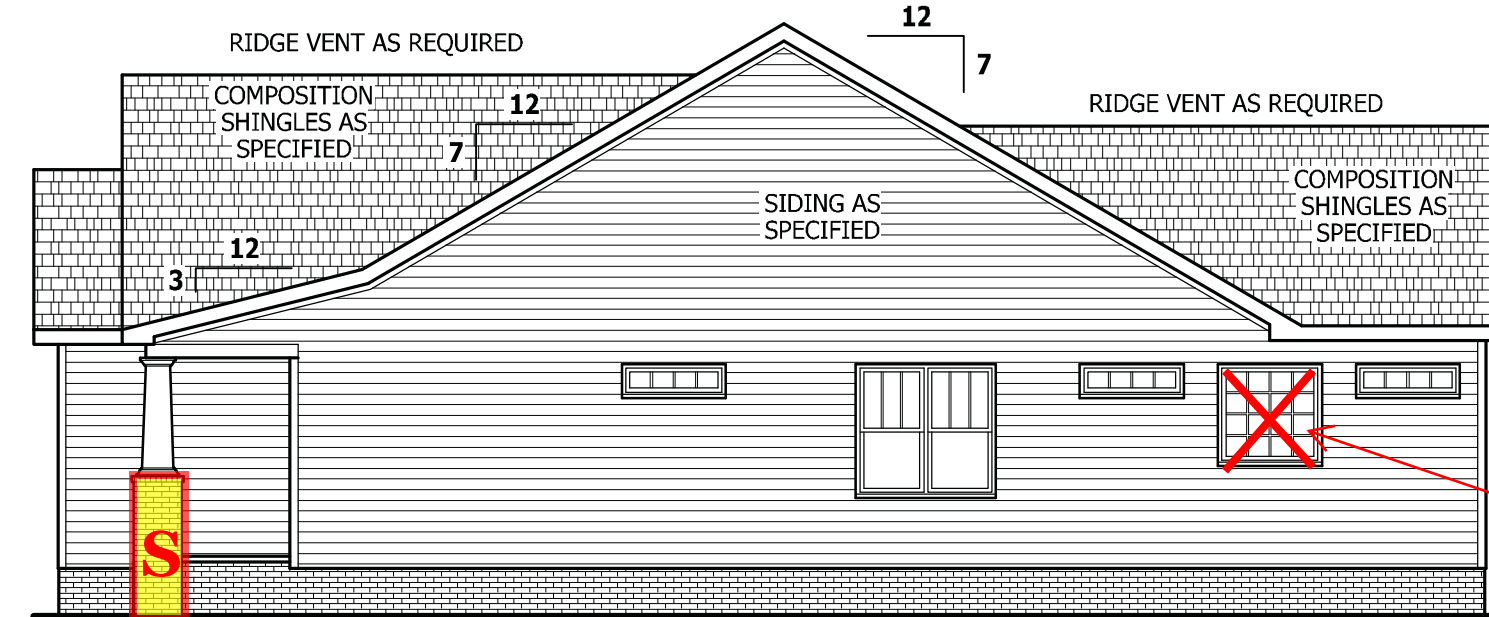

**RIGHT SIDE ELEVATION**  
SCALE 1/8" = 1'-0"

**GUARD RAIL NOTES**

**SECTION R312**  
**R312.1 Where required.** Guards shall be located along open-sided walking surfaces, including stairs, ramps and landings, that are located more than 30 inches (762 mm) measured vertically to the floor or grade below at any point within 36 inches (914 mm) horizontally to the edge of the open side. Insect screening shall not be considered as a guard.  
**R312.2 Height.** Required guards at open-sided walking surfaces, including stairs, porches, balconies or landings, shall be not less than 36 inches (914 mm) high measured vertically above the adjacent walking surface, adjacent fixed seating or the line connecting the leading edges of the treads.  
**Exceptions:**  
1. Guards on the open sides of stairs shall have a height not less than 34 inches (864 mm) measured vertically from a line connecting the leading edges of the treads.  
2. Where the top of the guard also serves as a handrail on the open sides of stairs, the top of the guard shall not be not less than 34 inches (864 mm) and not more than 38 inches (965 mm) measured vertically from a line connecting the leading edges of the treads.  
**R312.3 Opening limitations.** Required guards shall not have openings from the walking surface to the required guard height which allow passage of a sphere 4 inches (102 mm) in diameter.  
**Exceptions:**  
1. The triangular openings at the open side of a stair, formed by the riser, tread and bottom rail of a guard, shall not allow passage of a sphere 6 inches (153 mm) in diameter.  
2. Guards on the open sides of stairs shall not have openings which allow passage of a sphere 43/8 inches (111 mm) in diameter.

4010

PARGE

PURCHASER MUST VERIFY ALL DIMENSIONS AND CONDITIONS BEFORE CONSTRUCTION BEGINS. HAYNES HOME PLANS, INC. ASSUMES NO LIABILITY FOR CONTRACTORS PRACTICES AND PROCEDURES. CODES AND CONDITIONS MAY VARY WITH LOCATION. A LOCAL DESIGNER, ARCHITECT OR ENGINEER SHOULD BE CONSULTED BEFORE CONSTRUCTION. THESE DRAWINGS ARE INSTRUMENTS OF SERVICE AND AS SUCH SHALL REMAIN PROPERTY OF THE DESIGNER.

**ELEVATION - B**  
**Lindsay 1553**

**HAYNES WEAVER HOMES**  
**HOMEPANS, INC.**  
P.O. BOX 702, WAKE FOREST, NC 27388 919-485-6180 FAX 1-866-491-0396

**SQUARE FOOTAGE**

HEATED FIRST FLOOR	1553 SQ.FT.
TOTAL	1553 SQ.FT.
UNHEATED GARAGE	419 SQ.FT.
FRONT PORCH	103 SQ.FT.
FRONT PORCH EXT	66 SQ.FT.
REAR PORCH	117 SQ.FT.
TOTAL	705 SQ.FT.
UNHEATED OPTIONAL THIRD GARAGE	292 SQ.FT.
TOTAL	292 SQ.FT.

© Copyright 2020 Haynes Home Plans, Inc.  
**9/28/2020**  
**200505B**  
**PAGE 1 OF 6**

Z:\Builder\Weaver Development Company, Inc.\200825B Lindsay 1553 Left.aec

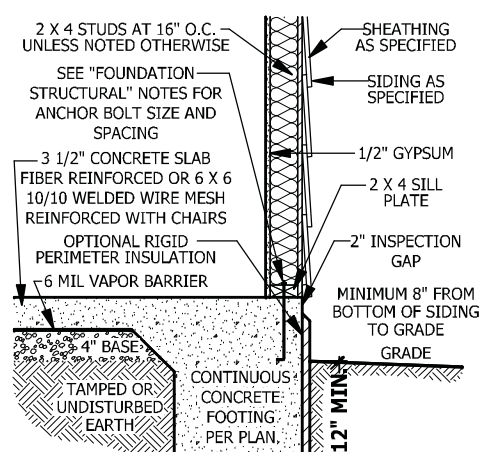

**A MONOLITHIC SECTION**  
SCALE 1/2" = 1'-0"

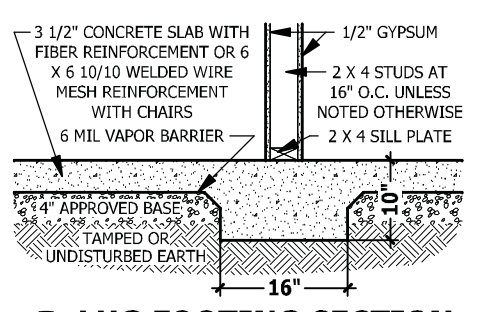

**B LUG FOOTING SECTION**  
SCALE 1/2" = 1'-0"

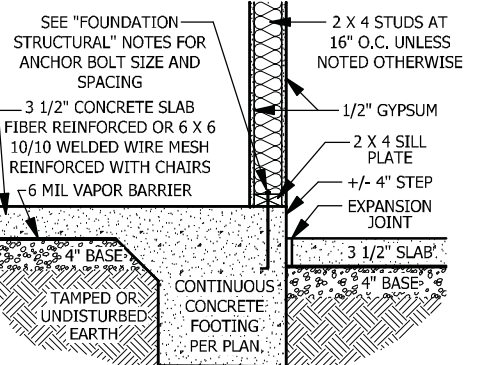

**C MONOLITHIC AT STEP**  
SCALE 1/2" = 1'-0"

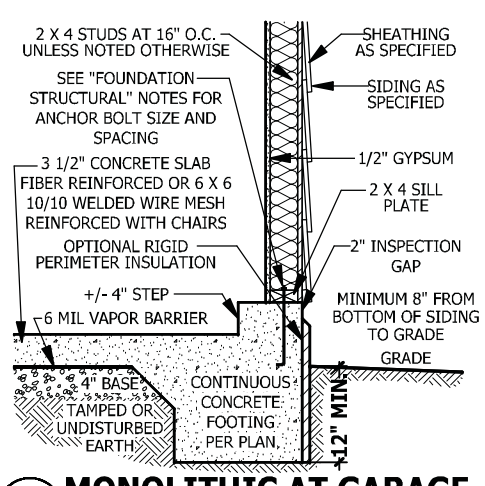

**D MONOLITHIC AT GARAGE**  
SCALE 1/2" = 1'-0"

**FOUNDATION STRUCTURAL**

115 to 130 mph wind zone (1 1/2 to 2 1/2 story)  
**CONTINUOUS FOOTING:** 16" wide and 8" thick minimum, 20" wide minimum at brick veneer. Must extended 2" to either side of supported wall.  
**GIRDERS:** (3) 2 X 10 girder unless noted otherwise.  
**PIERS:** 16" X 16" piers with 8" solid masonry cap on 30" X 30" X 10" concrete footing with maximum pier height of 64" with hollow masonry and 160" with solid masonry.  
**POINT LOADS:** ■ designates significant point load and should have solid blocking to pier, girder or foundation wall.  
**115 and 120 MPH ANCHORS BOLTS:** 1/2" diameter anchor bolts embedded minimum 7", maximum 6'-0" on center, within 12" of plate ends, and minimum two anchor bolts per plate.  
**130 MPH ANCHORS BOLTS:** 1/2" diameter anchor bolts embedded minimum 15", maximum 4'-0" on center, within 12" of plate ends, and minimum two anchor bolts per plate.  
**CONCRETE:** Concrete shall have a minimum 28 day strength of 3000 psi and a maximum 5" slump. Air entrained per table 402.2. All concrete shall be in accordance with ACI standards. All samples for pumping shall be taken from the exit end of the pump.  
**SOILS:** Allowable soil bearing pressure assumed to be 2000 PSF. The contractor must contact a geotechnical engineer and a structural engineer if unsatisfactory subsurface conditions are encountered. The surface area adjacent to the foundation wall shall be provided with adequate drainage, and shall be graded so as to drain surface water away from foundation walls.

**MONOLITHIC SLAB PLAN**

SCALE 1/4" = 1'-0"

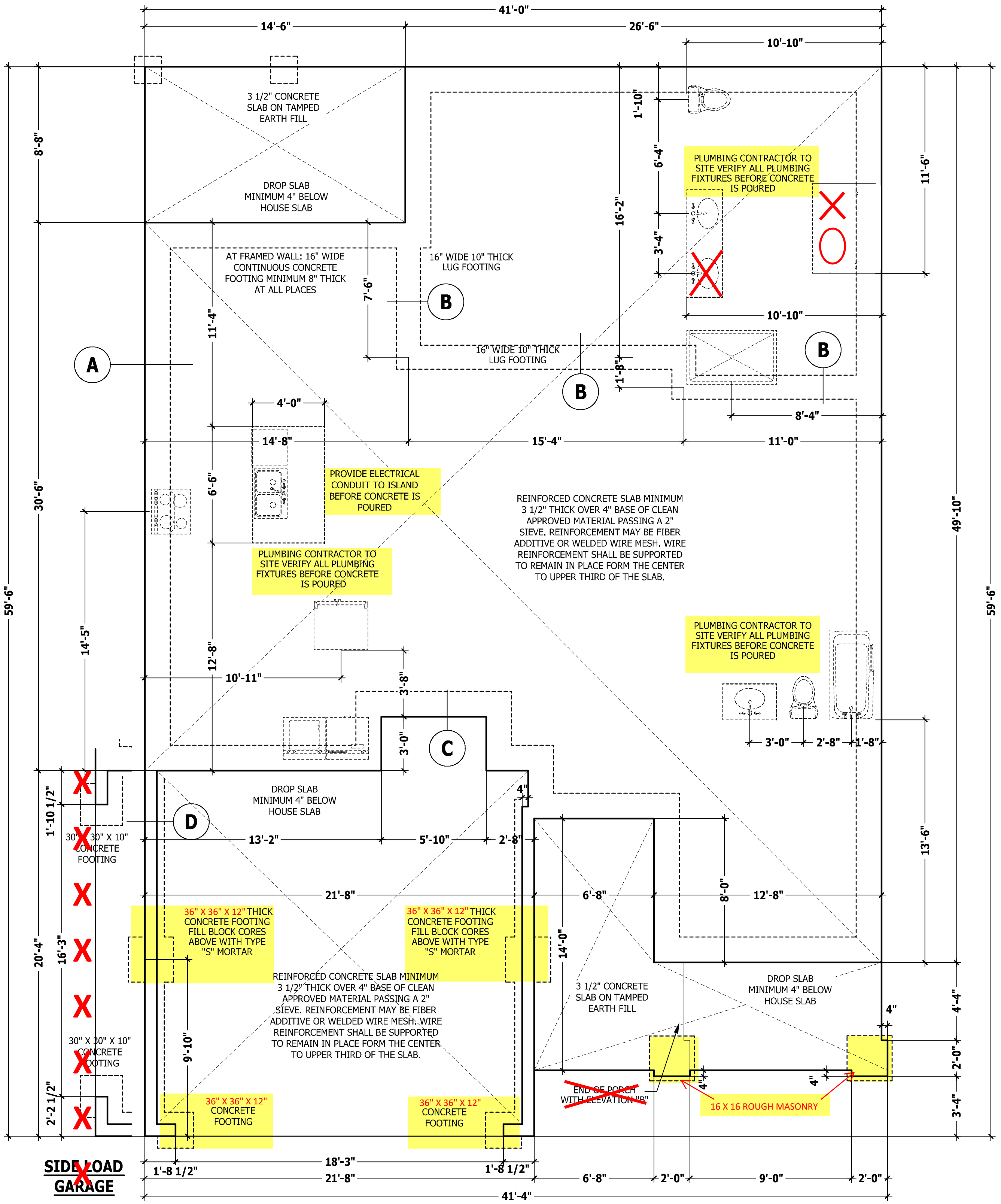

PURCHASER MUST VERIFY ALL DIMENSIONS AND CONDITIONS BEFORE CONSTRUCTION BEGINS. HAYNES HOME PLANS, INC. ASSUMES NO LIABILITY FOR CONTRACTORS PRACTICES AND PROCEDURES. CODES AND CONDITIONS MAY VARY WITH LOCATION. A LOCAL DESIGNER, ARCHITECT OR ENGINEER SHOULD BE CONSULTED BEFORE CONSTRUCTION. THESE DRAWINGS ARE INSTRUMENTS OF SERVICE AND AS SUCH SHALL REMAIN PROPERTY OF THE DESIGNER.

**MONOLITHIC SLAB PLAN**  
**Lindsay 1553**

**HAYNES WEAVER HOMES**  
HOME PLANS, INC.  
330 Waggoner Drive, Fayetteville, NC 28303  
910.630.2100 • 919.606.4696

**SQUARE FOOTAGE**

HEATED FIRST FLOOR TOTAL	1553 SQ. FT.
UNHEATED FRONT PORCH	103 SQ. FT.
UNHEATED FRONT PORCH EXT	66 SQ. FT.
UNHEATED REAR PORCH	117 SQ. FT.
UNHEATED GARAGE	705 SQ. FT.
UNHEATED THIRD GARAGE	292 SQ. FT.

© Copyright 2020 Haynes Home Plans, Inc.  
9/28/2020  
200505B  
PAGE 2 OF 6

PURCHASER MUST VERIFY ALL DIMENSIONS AND CONDITIONS BEFORE CONSTRUCTION BEGINS. HAYNES HOME PLANS, INC. ASSUMES NO LIABILITY FOR CONTRACTORS PRACTICES AND PROCEDURES. CODES AND CONDITIONS MAY VARY WITH LOCATION. A LOCAL DESIGNER, ARCHITECT OR ENGINEER SHOULD BE CONSULTED BEFORE CONSTRUCTION. THESE DRAWINGS ARE INSTRUMENTS OF SERVICE AND AS SUCH SHALL REMAIN PROPERTY OF THE DESIGNER.

**FIRST FLOOR PLAN**  
**Lindsay 1553**

**HAYNES WEAVER HOMES**  
**HOME PLANS, INC.**  
P.O. BOX 702, WAKE FOREST, NC 27588 919-485-6180 FAX 1-866-491-0396  
330 Wagoner Drive, Fayetteville, NC 28303  
910.630.2100 • 919.606.4696

SQUARE FOOTAGE	
<b>HEATED</b>	
FIRST FLOOR	1553 SQ.FT.
TOTAL	1553 SQ.FT.
<b>UNHEATED</b>	
GARAGE	419 SQ.FT.
FRONT PORCH	103 SQ.FT.
FRONT PORCH EXT	66 SQ.FT.
REAR PORCH	117 SQ.FT.
TOTAL	705 SQ.FT.
<b>UNHEATED OPTIONAL</b>	
THIRD GARAGE	292 SQ.FT.
TOTAL	292 SQ.FT.

© Copyright 2020  
Haynes Home Plans, Inc.  
**9/28/2020**  
**200505B**  
**PAGE 3 OF 6**

**ATTIC ACCESS**

**SECTION R807**  
**R807.1 Attic access.** An attic access opening shall be provided to attic areas that exceed 400 square feet (37.16 m2) and have a vertical height of 60 inches (1524 mm) or greater. The net clear opening shall not be less than 20 inches by 30 inches (508 mm by 762 mm) and shall be located in a hallway or other readily accessible location. A 30-inch (762 mm) minimum unobstructed headroom in the attic space shall be provided at some point above the access opening. See Section M1305.1.3 for access requirements where mechanical equipment is located in attics.  
**Exceptions:**  
1. Concealed areas not located over the main structure including porches, areas behind knee walls, dormers, bay windows, etc. are not required to have access.  
2. Pull down stair treads, stringers, handrails, and hardware may protrude into the net clear opening.

**DWELLING / GARAGE SEPARATION**

**REFER TO SECTIONS R302.5, R302.6, AND R302.7**  
**WALLS.** A minimum 1/2" gypsum board must be installed on all walls supporting floor/ceiling assemblies used for separation required by this section.  
**STAIRS.** A minimum of 1/2" gypsum board must be installed on the underside and exposed sides of all stairways.  
**CEILINGS.** A minimum of 1/2" gypsum must be installed on the garage ceiling if there are no habitable room above the garage. If there are habitable room above the garage a minimum of 5/8" type X gypsum board must be installed on the garage ceiling.  
**OPENING PENETRATIONS.** Openings between the garage and residence shall be equipped with solid wood doors not less than 1 3/8 inches (35 mm) in thickness, solid or honeycomb core steel doors not less than 1 3/8 inches (35 mm) thick, or 20-minute fire-rated doors.  
**DUCT PENETRATIONS.** Ducts in the garage and ducts penetrating the walls or ceilings separating the dwelling from the garage shall be constructed of a minimum No. 26 gage (0.48 mm) sheet steel or other approved material and shall have no openings into the garage.  
**OTHER PENETRATIONS.** Penetrations through the separation required in Section R302.6 shall be protected as required by Section R302.11, Item 4.

**SQUARE FOOTAGE**

HEATED	
FIRST FLOOR	1553 SQ.FT.
TOTAL	1553 SQ.FT.
UNHEATED	
GARAGE	419 SQ.FT.
FRONT PORCH	103 SQ.FT.
FRONT PORCH EXT	66 SQ.FT.
REAR PORCH	117 SQ.FT.
TOTAL	705 SQ.FT.
UNHEATED OPTIONAL	
THIRD GARAGE	292 SQ.FT.
TOTAL	292 SQ.FT.

**FIRST FLOOR PLAN**

SCALE 1/4" = 1'-0"

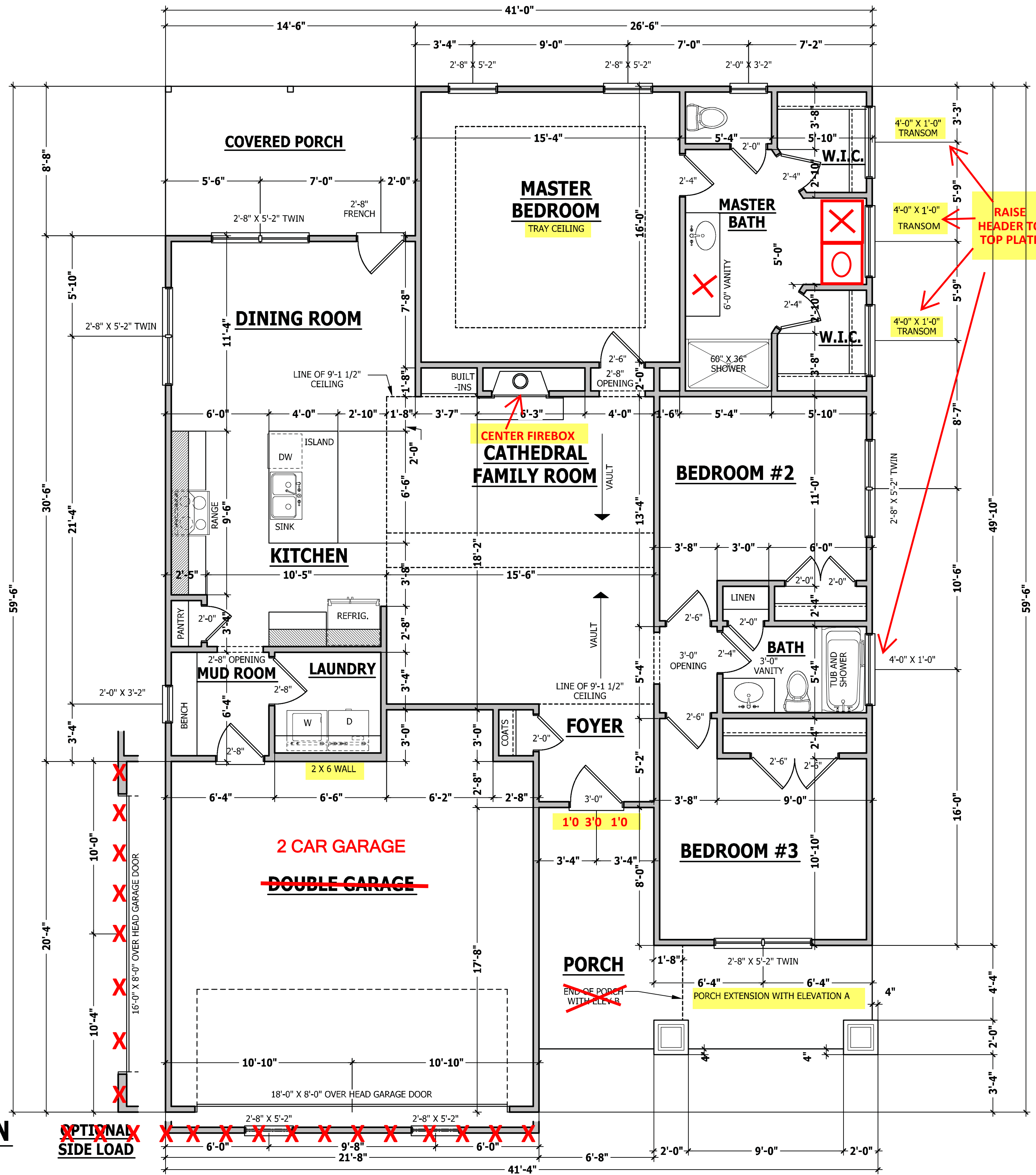

## STRUCTURAL NOTES

All construction shall conform to the latest requirements of the 2018 North Carolina Residential Building Code, plus all local codes and regulations. This document in no way shall be construed to supersede the code.

**JOB SITE PRACTICES AND SAFETY:** Haynes Home Plans, Inc. assumes no liability for contractor's practices and procedures or safety program. Haynes Home Plans, Inc. takes no responsibility for the contractor's failure to carry out the construction work in accordance with the contract documents. All members shall be framed, anchored, and braced in accordance with good construction practice and the building code.

USE	LIVE LOAD (PSF)	DEAD LOAD (PSF)	DEFLECTION (LL)
Attics without storage	10	10	L/240
Attics with limited storage	20	10	L/360
Attics with fixed stairs	40	10	L/360
Balconies and decks	40	10	L/360
Fire escapes	40	10	L/360
Guardrails and handrails	200	--	--
Guardrail in-fill components	50	--	--
Passenger vehicle garages	50	10	L/360
Rooms other than sleeping	40	10	L/360
Sleeping rooms	30	10	L/360
Stairs	40	10	L/360
Snow	20	--	--

**FRAMING LUMBER:** All non treated framing lumber shall be SPF #2 (Fb = 875 PSI) or SYP #2 (Fb = 750 PSI) and all treated lumber shall be SYP #2 (Fb = 750 PSI) unless noted otherwise.

### ENGINEERED WOOD BEAMS:

Laminated veneer Lumber (LVL) = Fb=2600 PSI, Fv=285 PSI, E=1.9x10<sup>6</sup> PSI  
Parallel strand lumber (PSL) = Fb=2900 PSI, Fv=290 PSI, E=2.0x10<sup>6</sup> PSI  
Laminated strand lumber (LSL) Fb=2250 PSI, Fv=400 PSI, E=1.55x10<sup>6</sup> PSI  
Install all connections per manufacturer's instructions.

**TRUSS AND I-JOIST MEMBERS:** All roof truss and I-joist layouts shall be prepared in accordance with this document. Trusses and I-joists shall be installed according to the manufacturer's specifications. Any change in truss or I-joist layout shall be coordinated with Haynes Homes Plans, Inc.

**LINTELS:** Brick lintels shall be 3 1/2" x 3 1/2" x 1/4" steel angle for up to 6'-0" span. 6" x 4" x 5/16" steel angle with 6" leg vertical for spans up to 9'-0" unless noted otherwise. 3 1/2" x 3 1/2" x 1/4" steel angle with 1/2" bolts at 2'-0" on center for spans up to 18'-0" unless noted otherwise.

**FLOOR SHEATHING:** OSB or CDX floor sheathing minimum 1/2" thick for 16" on center joist spacing, minimum 5/8" thick for 19.2" on center joist spacing, and minimum 3/4" thick for 24" on center joist spacing.

**ROOF SHEATHING:** OSB or CDX roof sheathing minimum 3/8" thick for 16" on center rafters and 7/16" for 24" on center rafters.

**CONCRETE AND SOILS:** See foundation notes.

## EXTERIOR HEADERS

- (2) 2 X 6 WITH 1 JACK STUD EACH END UNLESS NOTED OTHERWISE  
- KING STUDS EACH END PER TABLE BELOW

HEADER SPAN	< 3'	3'-4'	4'-8'	8'-12'	12'-16'
KING STUD(S)	1	2	3	5	6

## INTERIOR HEADERS

- LOAD BEARING HEADERS (2) 2 X 6 WITH 1 JACK STUD AND 1 KING STUD EACH END UNLESS NOTED OTHERWISE  
- NON LOAD BEARING HEADERS TO BE LADDER FRAMED

## BRACE WALL PANEL NOTES

**EXTERIOR WALLS:** All exterior walls to be sheathed with CS-WSP or CS-SFB in accordance with section R602.10.3 unless noted otherwise.

**GYPSUM:** All interior sides of exterior walls and both sides interior walls to have 1/2" gypsum installed. When not using method GB gypsum to be fastened per table R702.3.5. Method GB to be fastened per table R602.10.1.

**REQUIRED LENGTH OF BRACING:** Required brace wall length for each side of the circumscribed rectangle are interpolated per table R602.10.3. Methods CS-WSP and CS-SFB contribute their actual length. Method GB contributes 0.5 its actual length. Method PF contributes 1.5 times its actual length.

**HD:** 800 lbs hold down hold down device fastened to the edge of the brace wall panel closets to the corner.

**Methods** Per Table R602.10.1

**CS-WSP:** Shall be minimum 3/8" OSB or CDX nailed at 6" on center at edges and 12" on center at intermediate supports with 6d common nails or 8d(2 1/2" long x 0.113" diameter).

**CS-SFB:** Shall be minimum 1/2" structural fiber board nailed at 3" on center at edges and 3" on center at intermediate supports with 1 1/2" long x 0.12" diameter galvanized roofing nails.

**GB:** Interior walls show as GB are to have minimum 1/2" gypsum board on both sides of the wall fastened at 7" on center at edges and 7" on center at intermediate supports with minimum 5d cooler nails or #6 screws.

**PF:** Portal frame per figure R602.10.1

## ROOF TRUSS REQUIREMENTS

**TRUSS DESIGN.** Trusses to be designed and engineered in accordance with these drawings. Any variation with these drawings must be brought to Haynes Home Plan, Inc. attention before construction begins.

**ANCHORAGE.** All required anchors for trusses due to uplift or bearing shall meet the requirements as specified on the truss schematics.

**BEARING.** All trusses shall be designed for bearing on SPF #2 plates or ledgers unless noted otherwise.

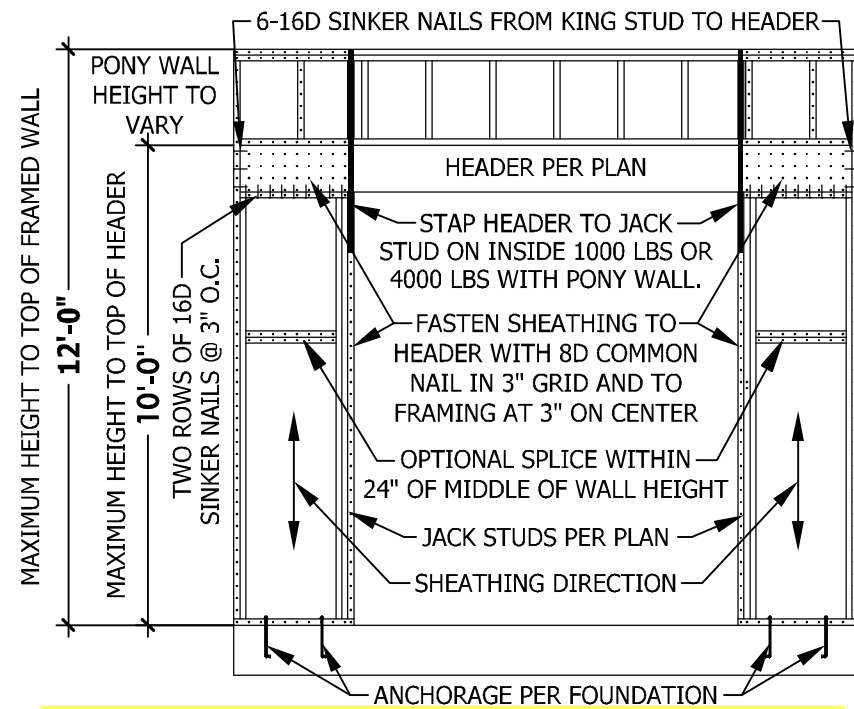

**PF PORTAL FRAME AT OPENING**  
(METHOD PF PER FIGURE AND SECTION R602.10.1)  
SCALE 1/4" = 1'-0"

## FULL FRONT PORCH

## FIRST FLOOR STRUCTURAL

SCALE 1/4" = 1'-0"

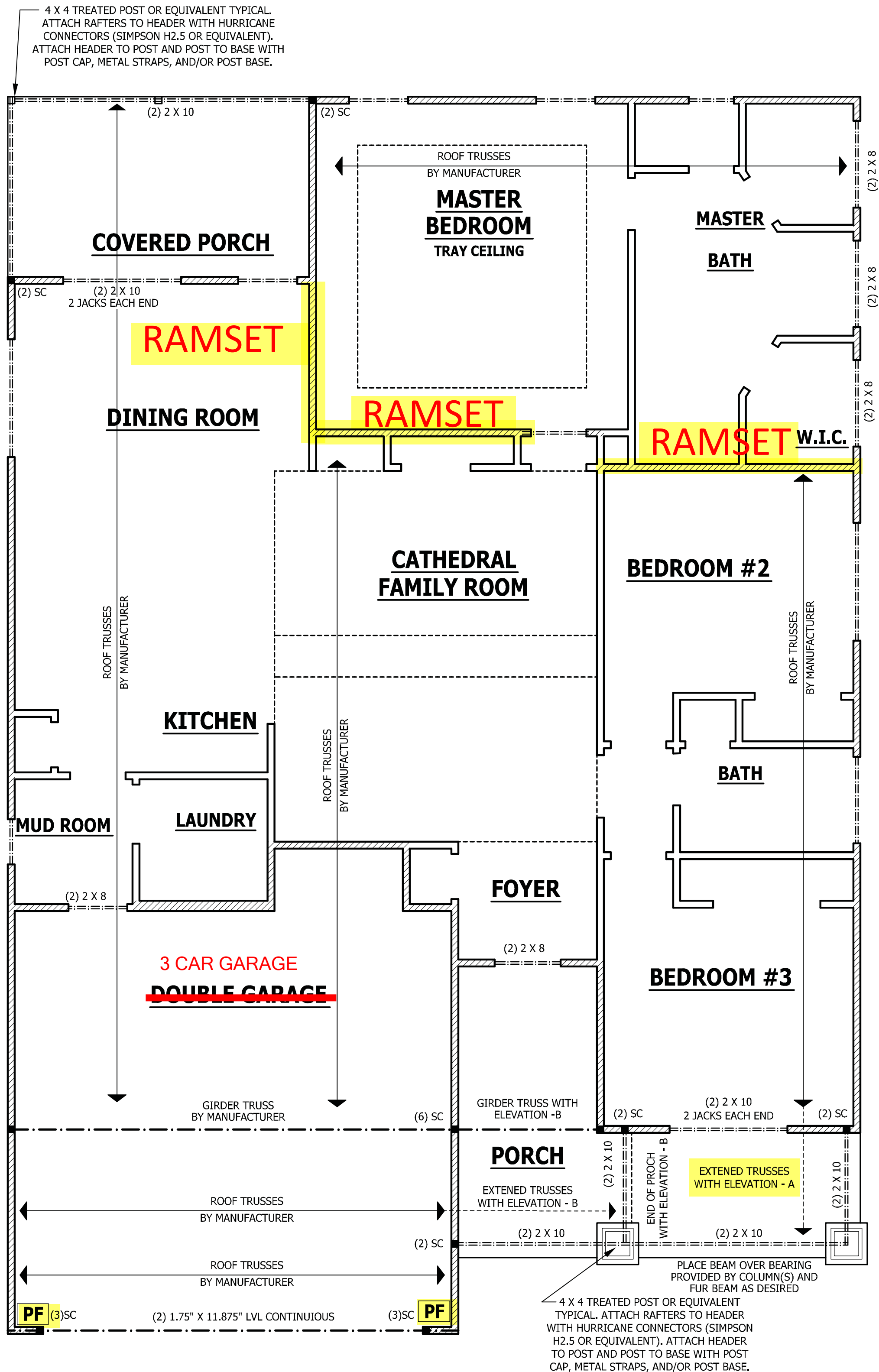

PURCHASER MUST VERIFY ALL DIMENSIONS AND CONDITIONS BEFORE CONSTRUCTION BEGINS.  
HAYNES HOME PLANS, INC. ASSUMES NO LIABILITY FOR CONTRACTOR'S PRACTICES AND PROCEDURES.  
CODES AND CONDITIONS MAY VARY WITH LOCATION. A LOCAL DESIGNER, ARCHITECT OR ENGINEER SHOULD BE CONSULTED BEFORE CONSTRUCTION.  
THESE DRAWINGS ARE INSTRUMENTS OF SERVICE AND AS SUCH SHALL REMAIN PROPERTY OF THE DESIGNER.

FIRST FLOOR STRUCTURAL

Lindsay 1553

HAYNES WE AVER HOMES

HOME PLANS, INC.  
910.630.2100 • 919.606.4696  
350 Waggoner Drive, Fayetteville, NC 28303

HAYNES HOME PLANS, INC.  
P.O. Box 702, Wake Forest, NC 27788 919-485-6180 FAX +866-491-0396

SQUARE FOOTAGE	
HEATED FIRST FLOOR TOTAL	1553 SQ. FT.
UNHEATED GARAGE	419 SQ. FT.
FRONT PORCH	103 SQ. FT.
FRONT PORCH EXT	66 SQ. FT.
REAR PORCH	117 SQ. FT.
TOTAL UNHEATED OPTIONAL THIRD GARAGE	705 SQ. FT.
TOTAL	292 SQ. FT.

© Copyright 2020 Haynes Home Plans, Inc.

9/28/2020

200505B

PAGE 4 OF 6

### ROOF TRUSS REQUIREMENTS

**TRUSS DESIGN.** Trusses to be designed and engineered in accordance with these drawings. Any variation with these drawings must be brought to Haynes Home Plan, Inc. attention before construction begins.

**ANCHORAGE.** All required anchors for trusses due to uplift or bearing shall meet the requirements as specified on the truss schematics.

**BEARING.** All trusses shall be designed for bearing on SPF #2 plates or ledgers unless noted otherwise.

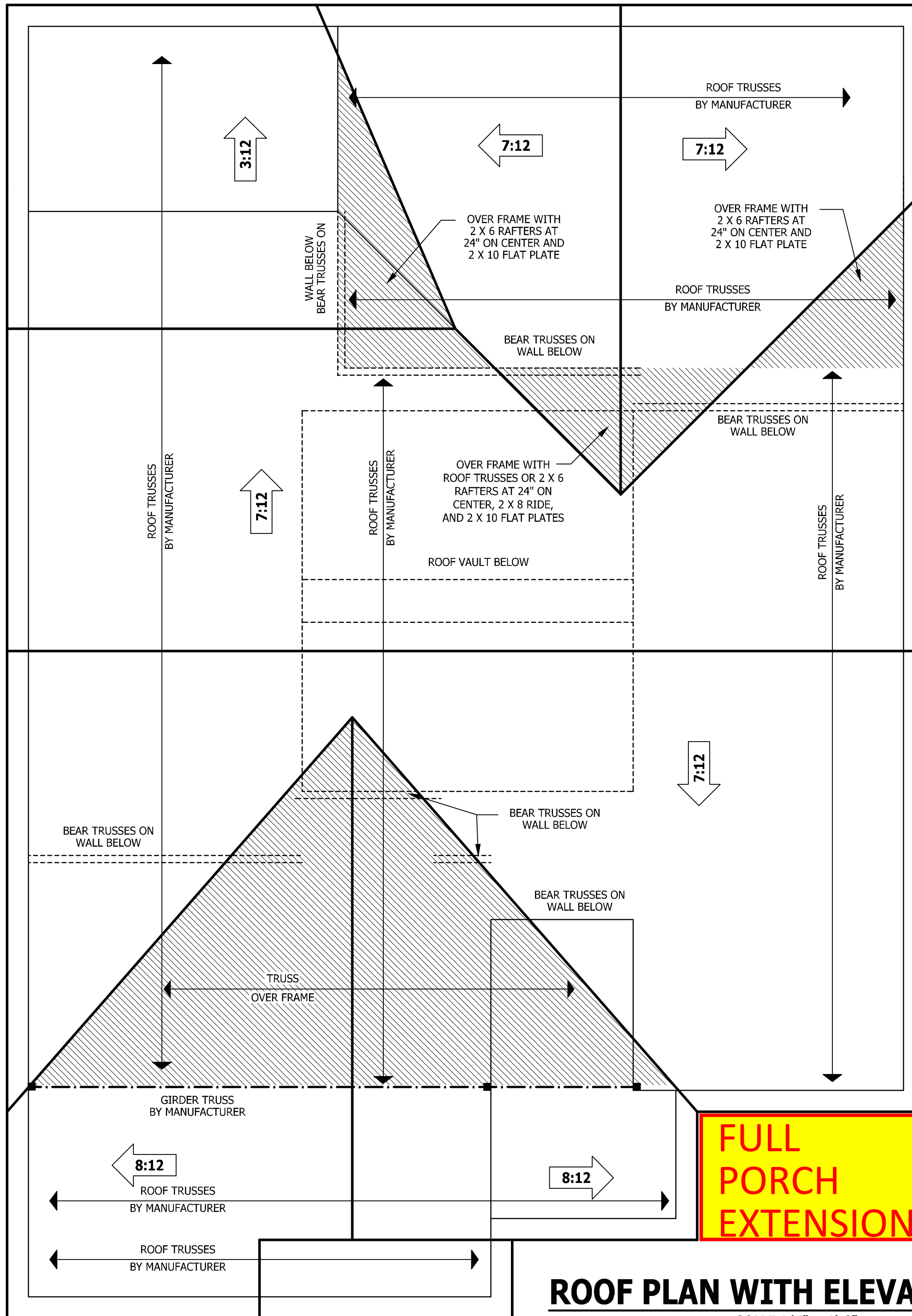

**ROOF PLAN WITH ELEVATION - B**

SCALE 1/4" = 1'-0"

PURCHASER MUST VERIFY ALL DIMENSIONS AND CONDITIONS BEFORE CONSTRUCTION BEGINS.  
 HAYNES HOME PLANS, INC. ASSUMES NO LIABILITY FOR CONTRACTORS PRACTICES AND PROCEDURES.  
 CODES AND CONDITIONS MAY VARY WITH LOCATION. A LOCAL DESIGNER, ARCHITECT OR ENGINEER SHOULD BE CONSULTED BEFORE CONSTRUCTION.  
 THESE DRAWING ARE INSTRUMENTS OF SERVICE AND AS SUCH SHALL REMAIN PROPERTY OF THE DESIGNER.

**ROOF PLAN WITH ELEVATION - B**  
**Lindsay 1553**

**HAYNES WEAVER HOMES**  
 HOME PLANS, INC.  
 910.630.2100 • 919.606.4696  
 350 Waggoner Drive, Fayetteville, NC 28303  
 P.O. Box 702, Wake Forest, NC 27588 919-485-6180, Fax 1-866-491-0396

SQUARE FOOTAGE	
<b>HEATED</b>	
FIRST FLOOR	1553 SQ. FT.
TOTAL	1553 SQ. FT.
<b>UNHEATED</b>	
GARAGE	419 SQ. FT.
FRONT PORCH	103 SQ. FT.
FRONT PORCH EXT	66 SQ. FT.
REAR PORCH	117 SQ. FT.
TOTAL	705 SQ. FT.
<b>UNHEATED OPTIONAL</b>	
THIRD GARAGE	292 SQ. FT.
TOTAL	292 SQ. FT.

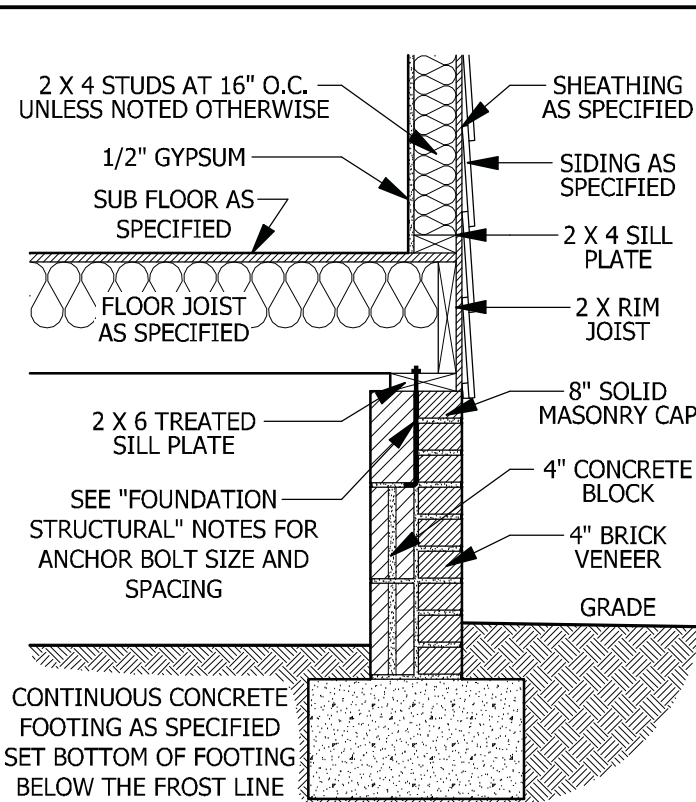

**A CRAWL SPACE WALL**  
SCALE 3/4" = 1'-0"

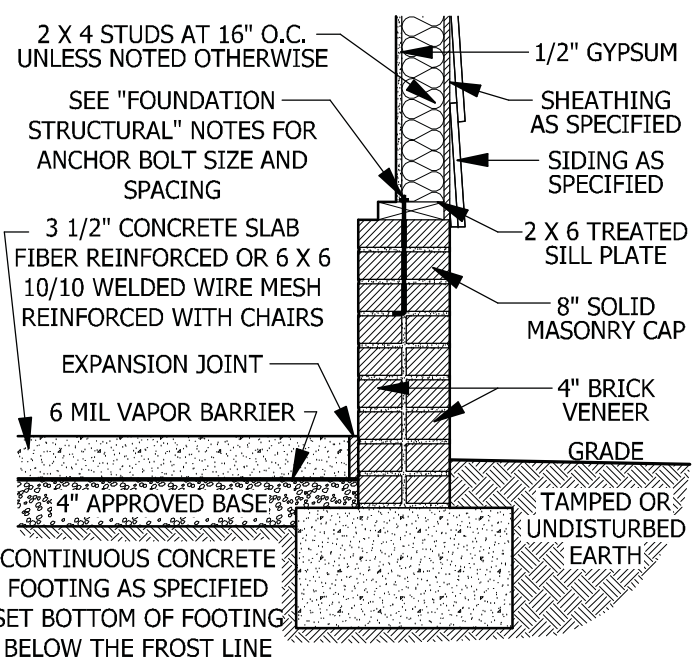

**D GARAGE STEM WALL**  
SCALE 3/4" = 1'-0"

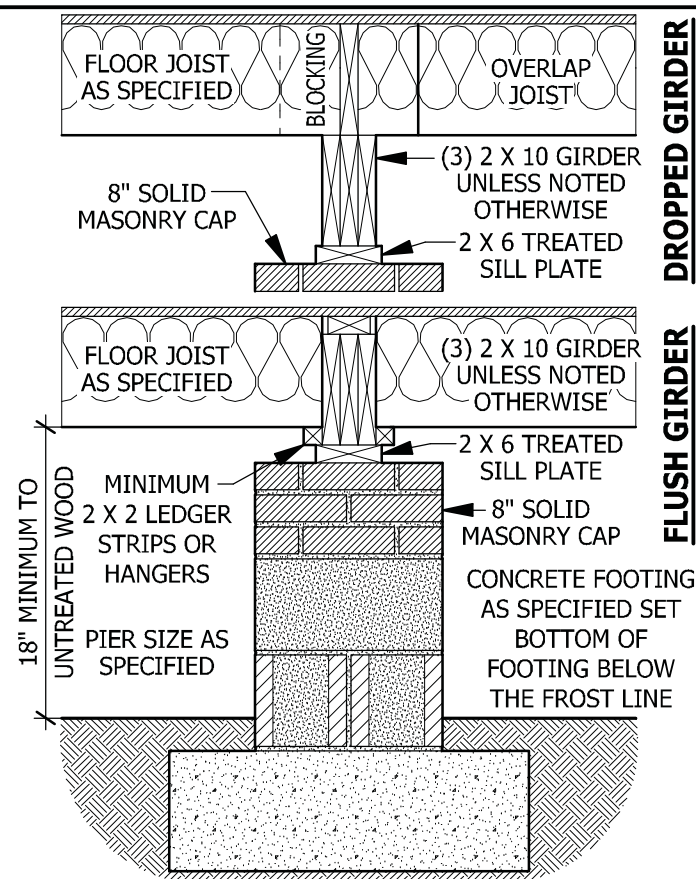

**B DROPPED/ FLUSH PIER**  
SCALE 3/4" = 1'-0"

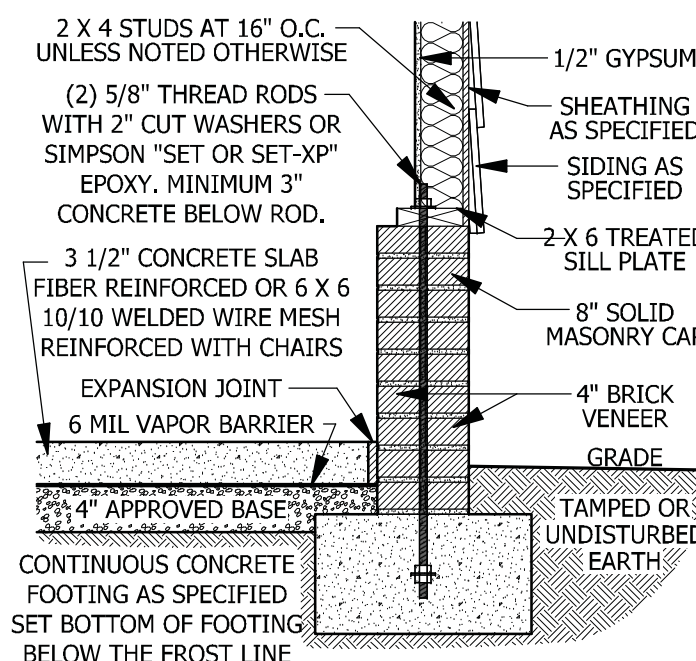

**E <48\"/>**

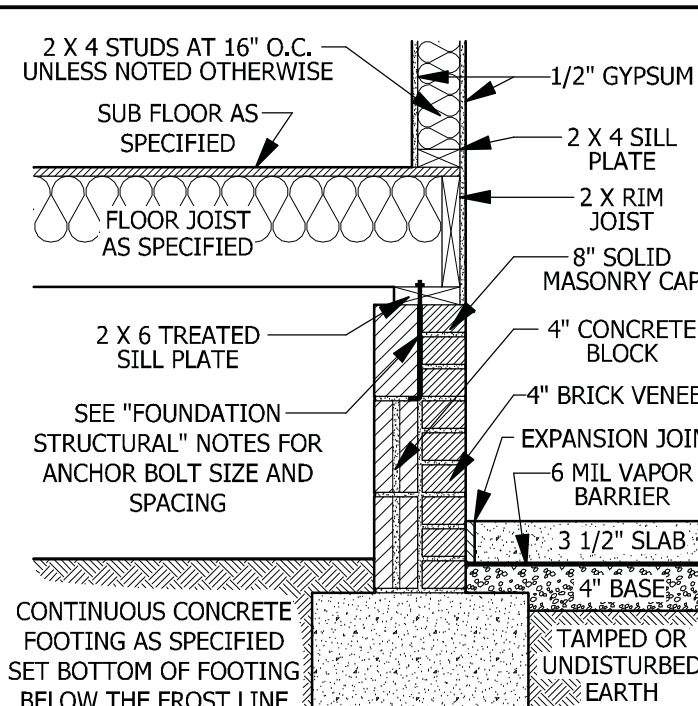

**C CRAWL SPACE AT GARGE**  
SCALE 3/4" = 1'-0"

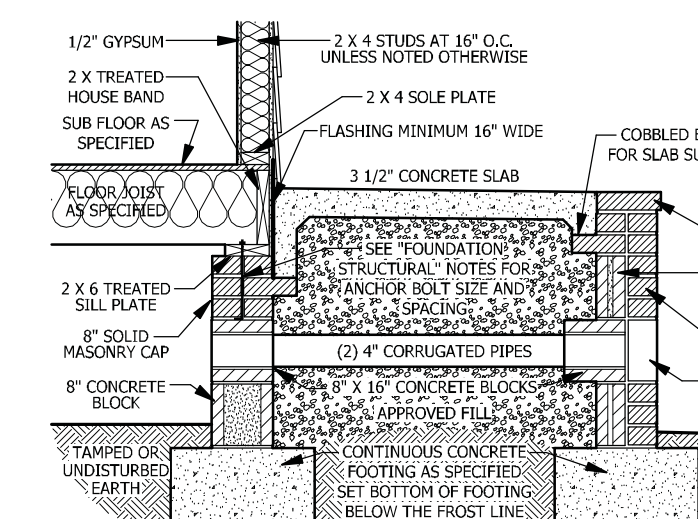

**F FILLED PORCH SECTION WITH VENT**  
SCALE 1/2" = 1'-0"

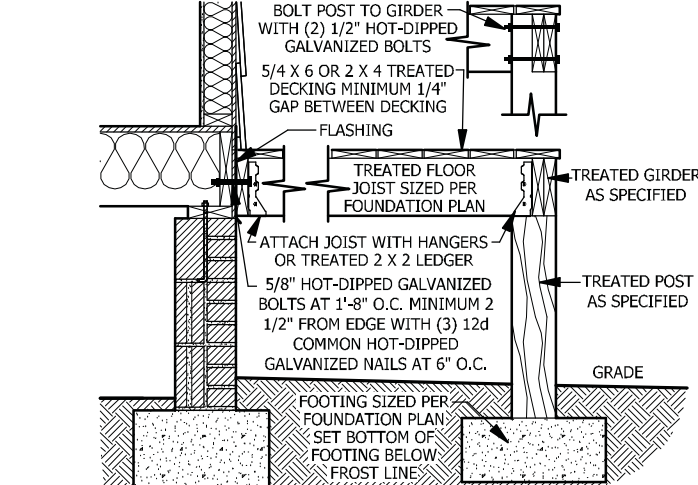

**G DECK ATTACHMENT**  
SCALE 1/2" = 1'-0"

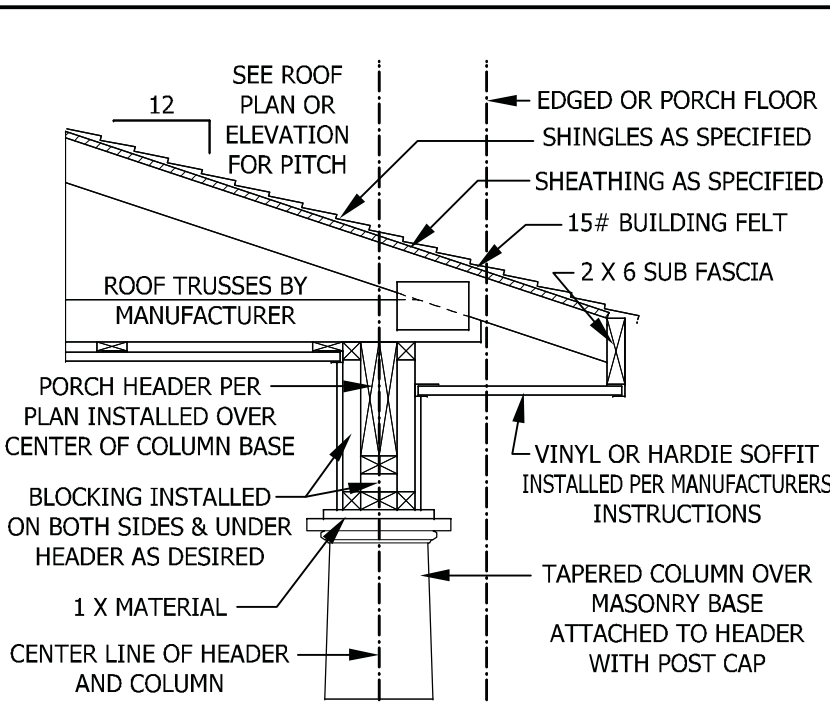

**PORCH HEADER WITH TAPERED COLUMN**  
SCALE 3/4" = 1'-0"

**CARBON MONOXIDE ALARMS**

**SECTION R315**  
**R315.1 Carbon monoxide alarms.** In new construction, dwelling units shall be provided with an approved carbon monoxide alarm installed outside of each separate sleeping area in the immediate vicinity of the bedroom(s) as directed by the alarm manufacturer.  
**R315.2 Where required in existing dwellings.** In existing dwellings, where interior alterations, repairs, fuel-fired appliance replacements, or additions requiring a permit occurs, or where one or more sleeping rooms are added or created, carbon monoxide alarms shall be provided in accordance with Section 315.1.  
**R315.3 Alarm requirements.** The required carbon monoxide alarms shall be audible in all bedrooms over background noise levels with all intervening doors closed. Single station carbon monoxide alarms shall be listed as complying with UL 2034 and shall be installed in accordance with this code and the manufacturer's installation instructions.

**DECK STAIR NOTES**

**SECTION AM110**  
**AM110.1 Stairs shall be constructed per Figure AM110.** Stringer spans shall be no greater than 7 foot span between supports. Spacing between stringers shall be based upon decking material used per AM107.1. Each Stringer shall have minimum 3 1/2 inches between step cut and back of stringer. If used, suspended headers shall be attached with 3/8 inch galvanized bolts with nuts and washers to securely support stringers at the top.

**DECK BRACING**

**SECTION AM109**  
**AM109.1 Deck bracing.** Decks shall be braced to provide lateral stability. The following are acceptable means to provide lateral stability.  
**AM109.1.1.** When the deck floor height is less than 4'-0" above finished grade per Figure AM109 and the deck is attached to the structure in accordance with Section AM104, lateral bracing is not required.  
**AM109.1.2.** 4 x 4 wood knee braces may be provided on each column in both directions. The knee braces shall attach to each post at a point not less than 1/3 of the post length from the top of the post, and the braces shall be angled between 45 degrees and 60 degrees from the horizontal. Knee braces shall be bolted to the post and the girder/double band with one 5/8 inch hot dipped galvanized bolt with nut and washer at both ends of the brace per Figure AM109.1  
**AM109.1.3.** For freestanding decks without knee braces or diagonal bracing, lateral stability may be provided by embedding the post in accordance with Figure AM109.2 and the following:  

POST SIZE	MAX. TRIBUTARY AREA	MAX. POST HEIGHT	EMBEDMENT DEPTH	CONCRETE DIAMETER
4 X 4	48 SF	4'-0"	2'-6"	1'-0"
6 X 6	120 SF	6'-0"	3'-6"	1'-8"

**AM109.1.4.** 2 x 6 diagonal vertical cross bracing may be provided in two perpendicular directions for freestanding decks or parallel to the structure at the exterior column line for attached decks. The 2 x 6's shall be attached to the posts with one 5/8 inch hot dipped galvanized bolt with nut and washer at each end of each bracing member per Figure AM109.3.  
**AM109.1.5.** For embedment of piles in Coastal Regions, see Chapter 45.

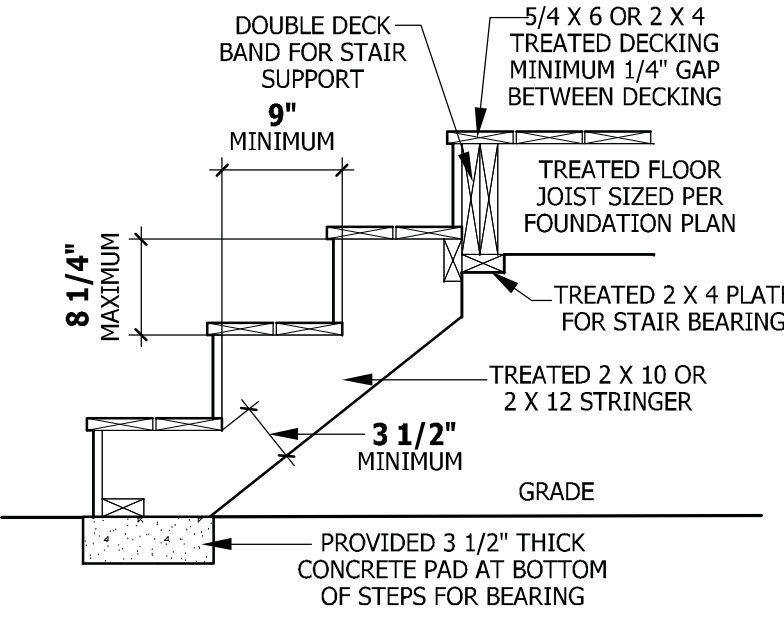

**FIGURE AM110**  
**TYPICAL DECK STAIR DETAIL**  
SCALE 3/4" = 1'-0"

**WEEP SCREDS**

All weep screeds and stone veneer to be installed per manufactures instructions and per the 2012 North Carolina Residential Building code.  
**R703.6.2.1 - A** minimum 0.019-inch (0.5 mm) (No. 26 galvanized sheet gage), corrosion-resistant weep screed or plastic weep screed, with a minimum vertical attachment flange of 31/2 inches (89 mm) shall be provided at or below the foundation plate line on exterior stud walls in accordance with ASTM C 926. The weep screed shall be placed a minimum of 4 inches (102 mm) above the earth or 2 inches (51 mm) above paved areas and shall be of a type that will allow trapped water to drain to the exterior of the building. The weather-resistant barrier shall lap the attachment flange. The exterior lath shall cover and terminate on the attachment flange of the weep screed.

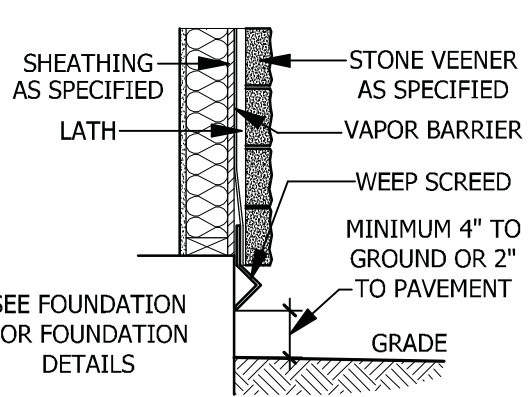

**WEEP SCREED**  
SCALE 3/4" = 1'-0"

**STAIRWAY NOTES**

**R311.7**  
**R311.7.2 Headroom.** The minimum headroom in all parts of the stairway shall not be less than 6 feet 8 inches (2032 mm) measured vertically from the sloped line adjoining the tread nosing or from the floor surface of the landing or platform on that portion of the stairway.  
**R311.7.4 Stair treads and risers.** Stair treads and risers shall meet the requirements of this section. For the purposes of this section all dimensions and dimensioned surfaces shall be exclusive of carpets, rugs or runners.  
**R311.7.4.1 Riser height.** The maximum riser height shall be 8 1/4 inches (210 mm). The riser shall be measured vertically between leading edges of the adjacent treads.  
**R311.7.4.2 Tread depth.** The minimum tread depth shall be 9 inches (229 mm). The tread depth shall be measured horizontally between the vertical planes of the foremost projection of adjacent treads and at a right angle to the tread's leading edge. Winder treads shall have a minimum tread depth of 9 inches (229 mm) measured as above at a point 12 inches (305 mm) from the side where the treads are narrower. Winder treads shall have a minimum tread depth of 4 inches (102 mm) at any point.  
**R311.7.4.3 Profile.** The radius of curvature at the nosing shall be no greater than 9/16 inch (14 mm). A nosing not less than 3/4 inch (19 mm) but not more than 1 1/4 inches (32 mm) shall be provided on stairways with solid risers.  
**R311.7.7 Handrails.** Handrails shall be provided on at least one side of each continuous run of treads or flight with four or more risers.  
**R311.7.7.1 Height.** Handrail height, measured vertically from the sloped plane adjoining the tread nosing, or finish surface of ramp slope, shall be not less than 34 inches (864 mm) and not more than 38 inches (965 mm).  
**Exceptions:**  
 1. The use of a volute, turnout or starting easing shall be allowed over the lowest tread.  
 2. When handrail fittings or bendings are used to provide continuous transition between flights, the transition from handrail to guardrail, or used at the start of a flight, the handrail height at the fittings or bendings shall be permitted to exceed the maximum height.  
**R311.7.7.2 Continuity.** Handrails for stairways shall be continuous for the full length of the flight, from a point directly above the top riser of the flight to a point directly above the lowest riser of the flight. Handrail ends shall be returned or shall terminate in newel posts or safety terminals. Handrails adjacent to a wall shall have a space of not less than 11/2 inch (38 mm) between the wall and the handrails.  
**Exceptions:**  
 1. Handrails shall be permitted to be interrupted by a newel post.  
 2. The use of a volute, turnout, starting easing or starting newel shall be allowed over the lowest tread.  
 3. Two or more separate rails shall be considered continuous if the termination of the rails occurs within 6 inches (152 mm) of each other. If transitioning between a wall-mounted handrail and a guardrail/handrail, the wall-mounted rail must return into the wall.

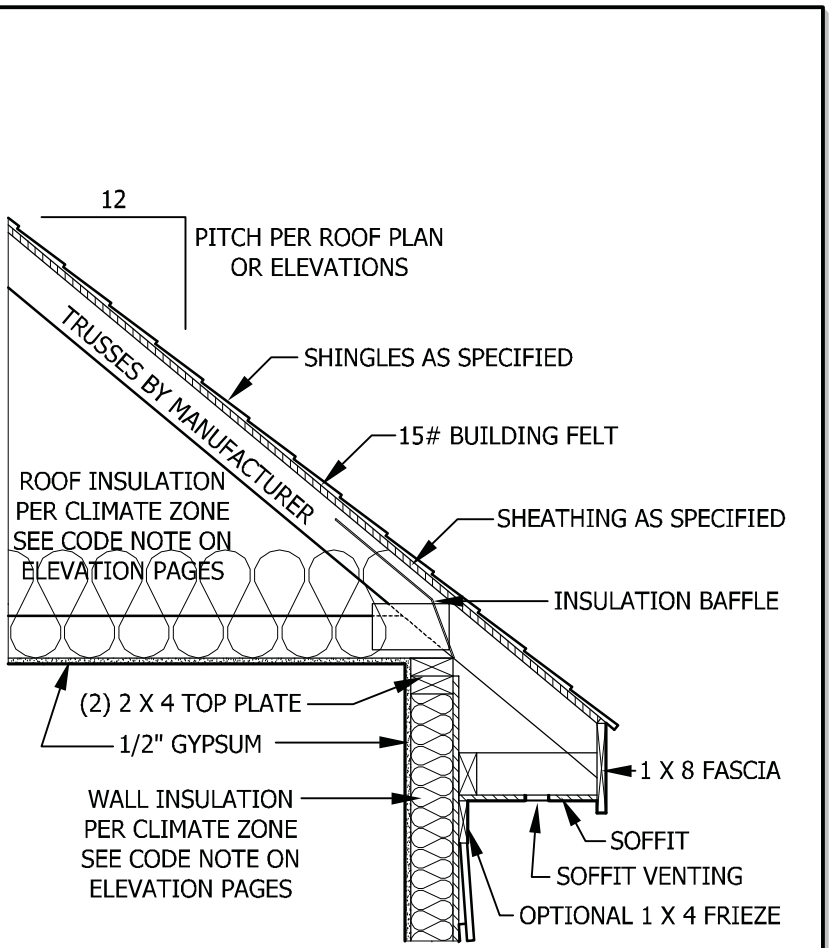

**TYPICAL WALL DETAIL**  
SCALE 3/4" = 1'-0"

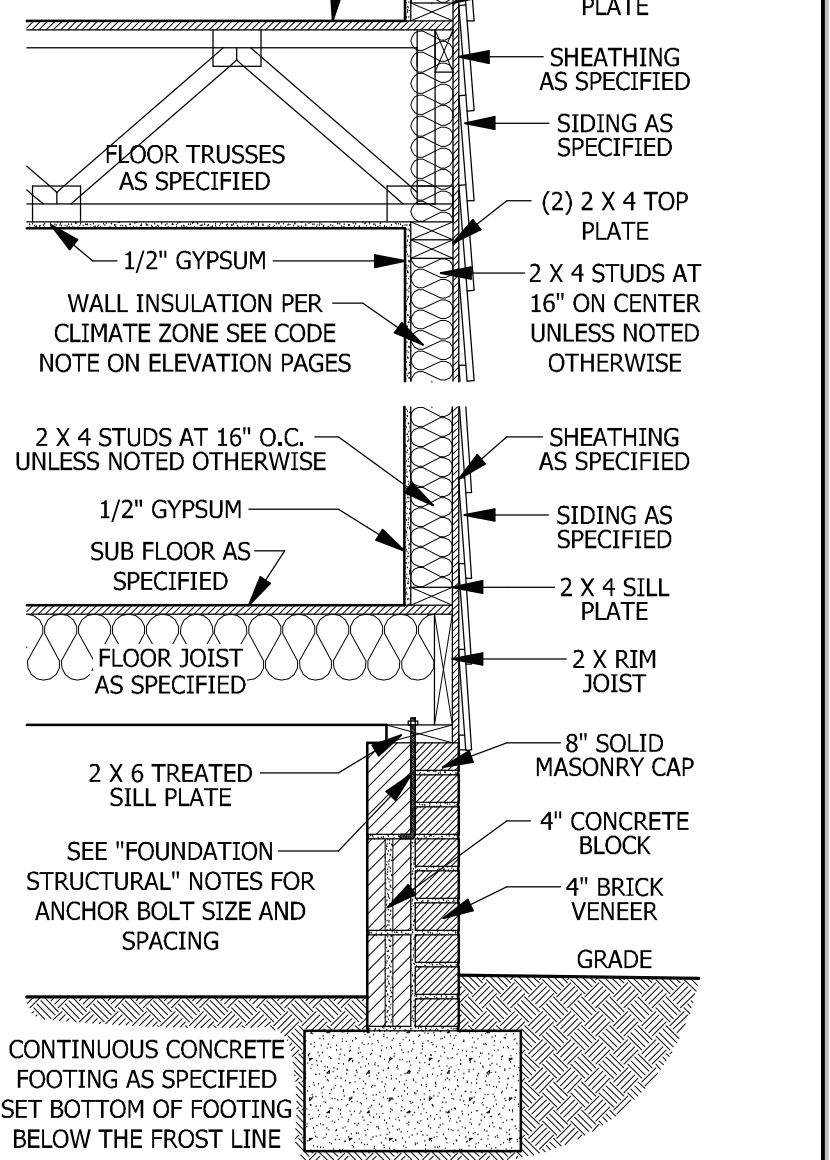

**TYPICAL STAIR DETAIL**  
SCALE 1/4" = 1'-0"

PURCHASER MUST VERIFY ALL DIMENSIONS AND CONDITIONS BEFORE CONSTRUCTION BEGINS. HAYNES HOME PLANS, INC. ASSUMES NO LIABILITY FOR CONTRACTORS PRACTICES AND PROCEDURES. CODES AND CONDITIONS MAY VARY WITH LOCATION. A LOCAL DESIGNER, ARCHITECT OR ENGINEER SHOULD BE CONSULTED BEFORE CONSTRUCTION. THESE DRAWING ARE INSTRUMENTS OF SERVICE AND AS SUCH SHALL REMAIN PROPERTY OF THE DESIGNER.

**TYPICAL DETAILS**  
**Lindsay 1553**

**HAYNES WEAVER HOMES**  
910.630.2100 • 919.606.4696  
350 Waggoner Drive, Fayetteville, NC 28403

**HAYNES HOME PLANS, INC.**  
P.O. Box 702, Wake Forest, NC 27588 919.495.6180 Fax: +866.491.4396

SQUARE FOOTAGE	
HEATED FIRST FLOOR	1553 SQ. FT.
TOTAL	1553 SQ. FT.
UNHEATED GARAGE	419 SQ. FT.
FRONT PORCH	103 SQ. FT.
FRONT PORCH EXT	16 SQ. FT.
REAR PORCH	117 SQ. FT.
TOTAL	705 SQ. FT.
UNHEATED OPTIONAL THIRD GARAGE	292 SQ. FT.
TOTAL	292 SQ. FT.

© Copyright 2020 Haynes Home Plans, Inc.  
9/28/2020  
200505B  
PAGE 6 OF 6

PURCHASER MUST VERIFY ALL DIMENSIONS AND CONDITIONS BEFORE CONSTRUCTION BEGINS. HAYNES HOME PLANS, INC. ASSUMES NO LIABILITY FOR CONTRACTORS PRACTICES AND PROCEDURES. CODES AND CONDITIONS MAY VARY WITH LOCATION, A LOCAL DESIGNER, ARCHITECT OR ENGINEER SHOULD BE CONSULTED BEFORE CONSTRUCTION. THESE DRAWINGS ARE INSTRUMENTS OF SERVICE AND AS SUCH SHALL REMAIN PROPERTY OF THE DESIGNER.

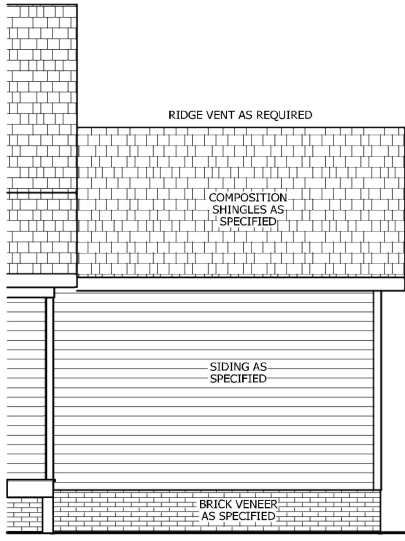

**REAR ELEVATION**

SCALE 1/8" = 1'-0"

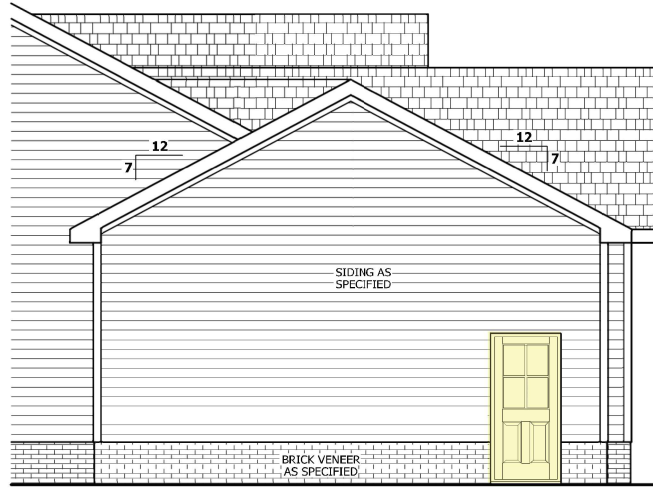

**RIGHT SIDE ELEVATION**

SCALE 1/4" = 1'-0"

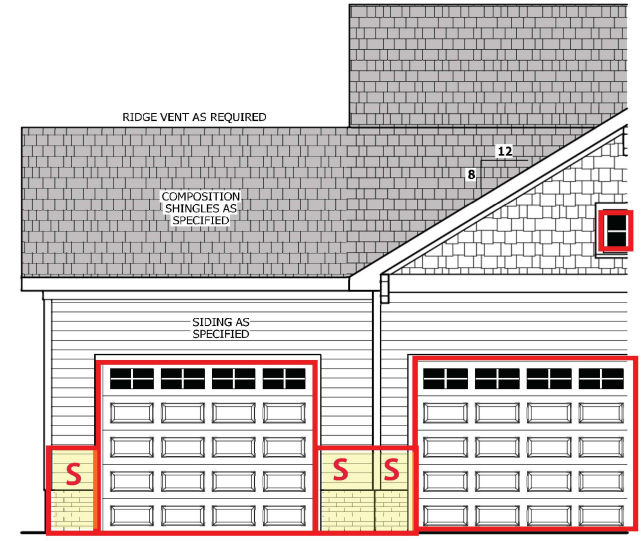

**FRONT ELEVATION**

SCALE 1/4" = 1'-0"

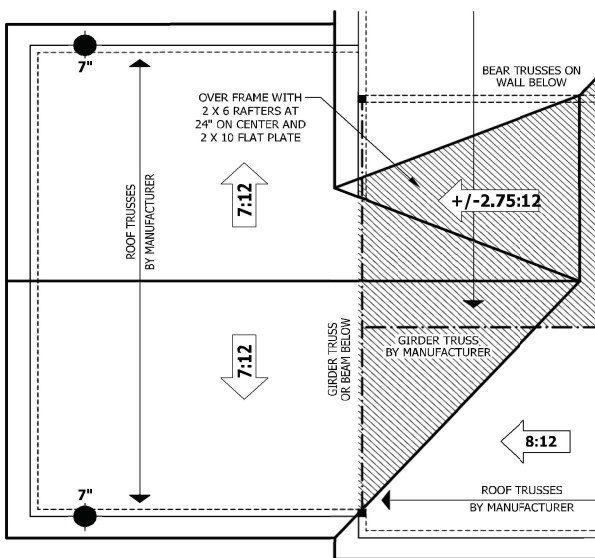

**ROOF PLAN**

SCALE 1/4" = 1'-0"

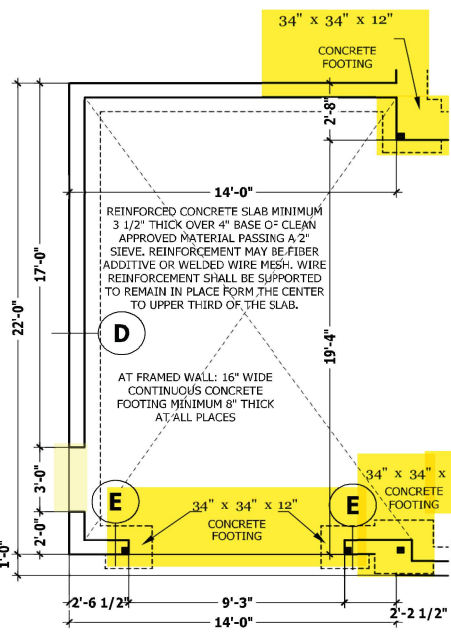

**MONOLITHIC SLAB PLAN**

SCALE 1/4" = 1'-0"

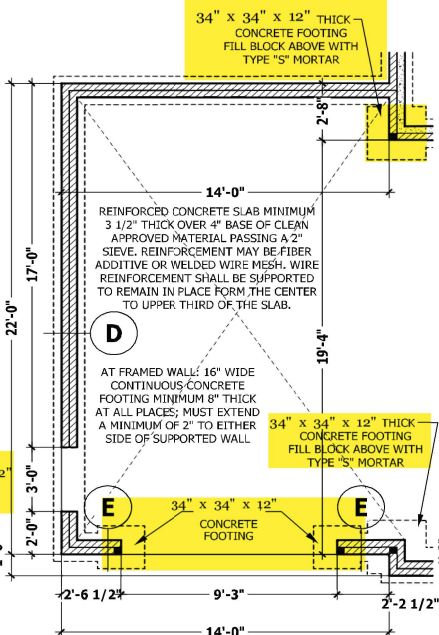

**CRAWL SPACE / STEM WALL**

SCALE 1/4" = 1'-0"

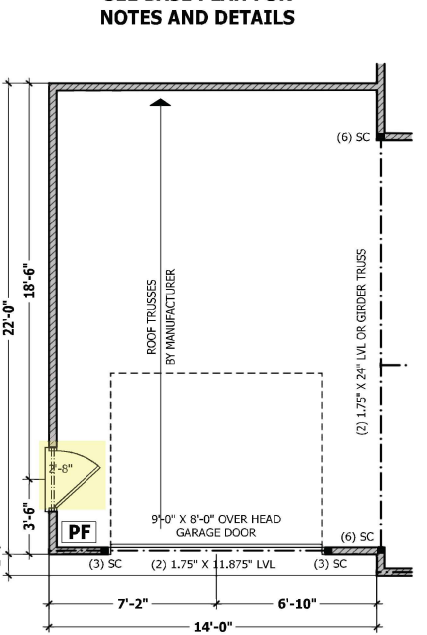

**FIRST FLOOR PLAN**

SCALE 1/4" = 1'-0"

**FRONT LOAD THIRD CAR**  
**Lindsay 1553**

**HAYNES WEAVER**  
**HOME PLANS, INC.**  
910.630.2100 • 919.606.4696  
© Copyright 2020 Haynes Home Plans, Inc. Raleigh, NC 27608

<b>SQUARE FOOTAGE</b>	
HEATED	1583 SQ.FT.
UNHEATED	1583 SQ.FT.
TOTAL	3166 SQ.FT.
OVERHEAD GARAGE DOOR	72 SQ.FT.
FRONT PORCH EXT	66 SQ.FT.
FRONT PORCH	175 SQ.FT.
TOTAL	713 SQ.FT.
UNHEATED OPTIONAL	292 SQ.FT.
TOTAL GARAGE	302 SQ.FT.

© Copyright 2020 Haynes Home Plans, Inc.  
**9/28/2020**  
**200505B**  
**ADDENDUM**



**ROOF & FLOOR TRUSSES & BEAMS**

Reilly Road Industrial Park  
 Fayetteville, N.C. 28309  
 Phone: (910) 864-8787  
 Fax: (910) 864-4444

Bearing reactions less than or equal to 3000# are deemed to comply with the prescriptive Code requirements. The contractor shall refer to the attached Tables ( derived from the prescriptive Code requirements ) to determine the minimum foundation size and number of wood studs required to support reactions greater than 3000# but not greater than 15000#. A registered design professional shall be retained to design the support system for any reaction that exceeds those specified in the attached Tables. A registered design professional shall be retained to design the support system for all reactions that exceed 15000#.

Signature Lenny Norris  
**Lenny Norris**

**LOAD CHART FOR JACK STUDS**

(BASED ON TABLES R502.5(1) & (b))  
 NUMBER OF JACK STUDS REQUIRED @ EA END OF HEADER/GIRDER

END REACTION (UP TO)	REQ. STUDS FOR (1) 1" X 4" HEADER	END REACTION (UP TO)	REQ. STUDS FOR (1) 1" X 4" HEADER	END REACTION (UP TO)	REQ. STUDS FOR (1) 1" X 4" HEADER
1700	1	2550	1	3400	1
3400	2	5100	2	6800	2
5100	3	7650	3	10200	3
6800	4	10200	4	13600	4
8500	5	12750	5	17000	5
10200	6	15300	6		
11900	7				
13600	8				
15300	9				

BUILDER	Weaver Homes, Inc.	CITY / CO.	Sanford / Harnett
JOB NAME	Lot 31 West Preserve	ADDRESS	143 Oleander Ln.
PLAN	Lindsay 1553 B/*FP/3CG	MODEL	ROOF
SEAL DATE	Seal Date	DATE REV.	/ /
QUOTE #	Quote #	DRAWN BY	Lenny Norris
JOB #	J0124-0298	SALES REP.	Lenny Norris

**BEAM LEGEND**

PlotID	Length	Product	Plies	Net Qty	Fab Type
GDH 9' FL (dropped)	14-00-00	1-3/4" x 11-7/8" LVL Kerto-S	2	2	FF
GDH 18' FL (dropped)	22-00-00	1-3/4" x 14" LVL Kerto-S	2	2	FF
PB1	20-00-00	2x10 SP No.2	2	2	FF
PB3	16-00-00	2x10 SP No.2	2	2	FF
PB4	10-00-00	2x10 SP No.2	2	2	FF
PB2	8-00-00	2x10 SP No.2	2	2	FF

**Estimation**

Name	Selection	Formula	Calculation
Roof Area	1st Floor	Roof Area	3338.42
Roof Decking	1st Floor	Roof Decking	115

**Hatch Legend**

= MAIN LOAD BEARING WALLS @ 9-1-8

<span style="background-color: pink; border: 1px solid black; display: inline-block; width: 15px; height: 10px;"></span>	HUS28	USP	15	16d/3-1/2	16d/3-1/2"
<span style="background-color: green; border: 1px solid black; display: inline-block; width: 15px; height: 10px;"></span>	THD28-2	USP	1	NA	16d/3-1/2"

*All Truss Reactions are Less than 3,000 lbs. Unless Noted Otherwise.*

-- Denotes Reaction Greater than 3,000 lbs. Reaction / # of Studs

▲ = Denotes Left End of Truss (Reference Engineered Truss Drawing)

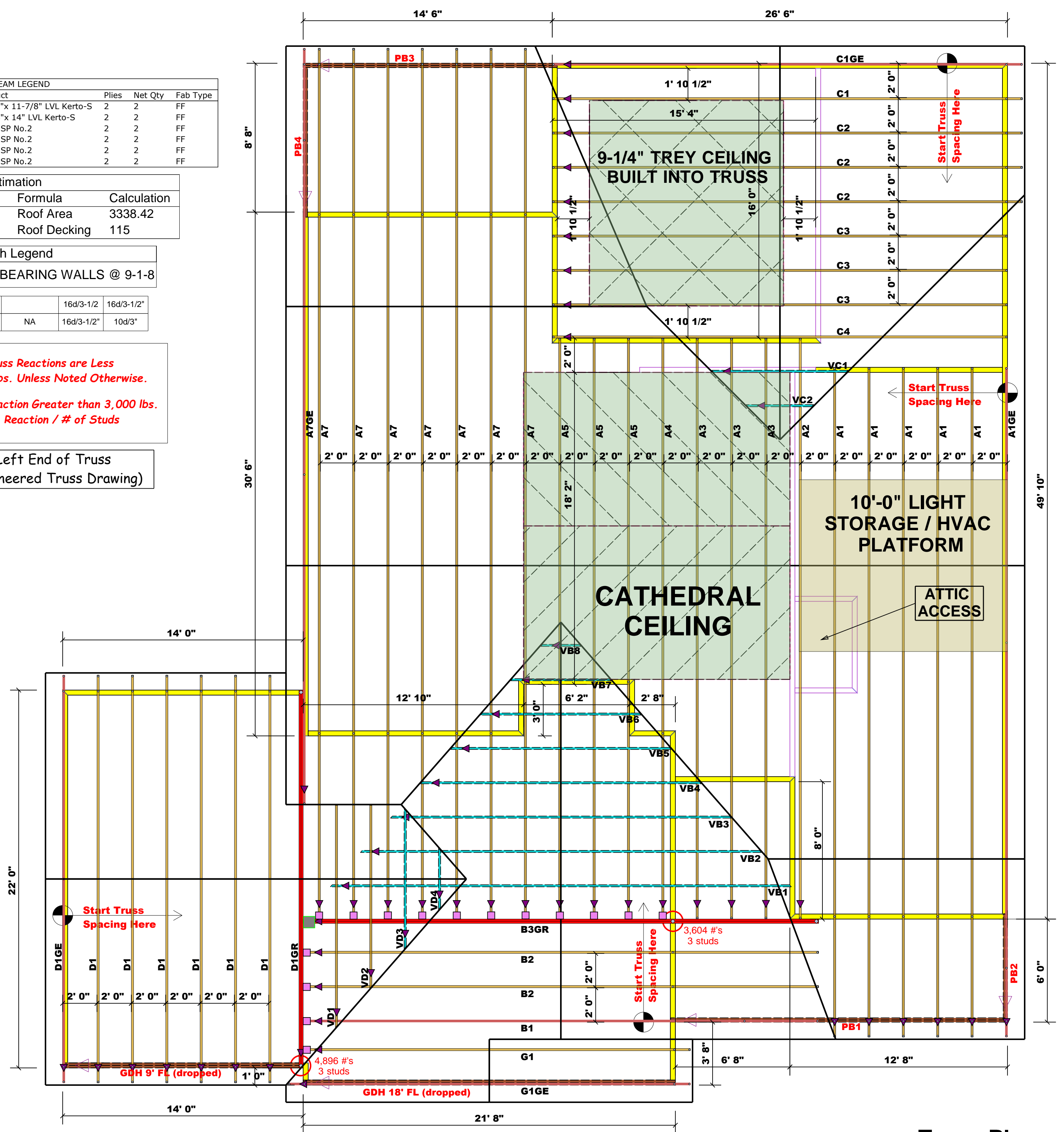

**Truss Placement Plan**  
 SCALE: 1/4" = 1'-0"

THIS IS A TRUSS PLACEMENT DIAGRAM ONLY. These trusses are designed as individual building components to be incorporated into the building design at the specification of the building designer. See individual design sheets for each truss design identified on the placement drawing. The building designer is responsible for temporary and permanent bracing of the roof and floor system and for the overall structure. The design of the truss support structure including headers, beams, walls, and columns is the responsibility of the building designer. For general guidance regarding bracing, consult BCSI-B1 and BCSI-B3 provided with the truss delivery package or online @ sbcindustry.com





# ROOF & FLOOR TRUSSES & BEAMS

Reilly Road Industrial Park  
Fayetteville, N.C. 28309  
Phone: (910) 864-8787  
Fax: (910) 864-4444

Bearing reactions less than or equal to 3000# are deemed to comply with the prescriptive Code requirements. The contractor shall refer to the attached Tables ( derived from the prescriptive Code requirements ) to determine the minimum foundation size and number of wood studs required to support reactions greater than 3000# but not greater than 15000#. A registered design professional shall be retained to design the support system for any reaction that exceeds those specified in the attached Tables. A registered design professional shall be retained to design the support system for all reactions that exceed 15000#.

Signature Lenny Norris  
Lenny Norris

BEAM LEGEND					
PlotID	Length	Product	Plies	Net Qty	Fab Type
GDH 9' FL (dropped)	14' 0"	1-3/4"x 11-7/8" LVL Kerto-S	2	2	FF
GDH 18' FL (dropped)	22' 0"	1-3/4"x 14" LVL Kerto-S	2	2	FF
PB1	20' 0"	2x10 SP No.2	2	2	FF
PB3	16' 0"	2x10 SP No.2	2	2	FF
PB4	10' 0"	2x10 SP No.2	2	2	FF
PB2	8' 0"	2x10 SP No.2	2	2	FF

Estimation			
Name	Selection	Formula	Calculation
Roof Area	1st Floor	Roof Area	3338.42
Roof Decking	1st Floor	Roof Decking	115

Hatch Legend					
	= MAIN LOAD BEARING WALLS @ 9-1-8				
	HUS28	USP	15	16d/3-1/2"	16d/3-1/2"
	THD28-2	USP	1	NA	16d/3-1/2"

All Truss Reactions are Less than 3,000 lbs. Unless Noted Otherwise.

○ -- Denotes Reaction Greater than 3,000 lbs. Reaction / # of Studs

▲ = Denotes Left End of Truss (Reference Engineered Truss Drawing)

### LOAD CHART FOR JACK STUDS

(BASED ON TABLES R502.5(1) & (b))  
NUMBER OF JACK STUDS REQUIRED @ EA END OF HEADER/GIRDER

END REACTION (UP TO)	REQ. STUDS FOR (1) 1" X 4" HEADER	END REACTION (UP TO)	REQ. STUDS FOR (1) 1" X 4" HEADER	END REACTION (UP TO)	REQ. STUDS FOR (1) 1" X 4" HEADER
1700	1	2550	1	3400	1
3400	2	5100	2	6800	2
5100	3	7650	3	10200	3
6800	4	10200	4	13600	4
8500	5	12750	5	17000	5
10200	6	15300	6		
11900	7				
13600	8				
15300	9				

BUILDER	Weaver Homes, Inc.	CITY / CO.	Sanford / Harnett
JOB NAME	Lot 31 West Preserve	ADDRESS	143 Oleander Ln.
PLAN	Lindsay 1553 B/*FP/3CG	MODEL	ROOF
SEAL DATE	Seal Date	DATE REV.	/ /
QUOTE #	Quote #	DRAWN BY	Lenny Norris
JOB #	J0124-0298	SALES REP.	Lenny Norris

THIS IS A TRUSS PLACEMENT DIAGRAM ONLY. These trusses are designed as individual building components to be incorporated into the building design at the specification of the building designer. See individual design sheets for each truss design identified on the placement drawing. The building designer is responsible for temporary and permanent bracing of the roof and floor system and for the overall structure. The design of the truss support structure including headers, beams, walls, and columns is the responsibility of the building designer. For general guidance regarding bracing, consult BCSI-B1 and BCSI-B3 provided with the truss delivery package or online @ sbcindustry.com

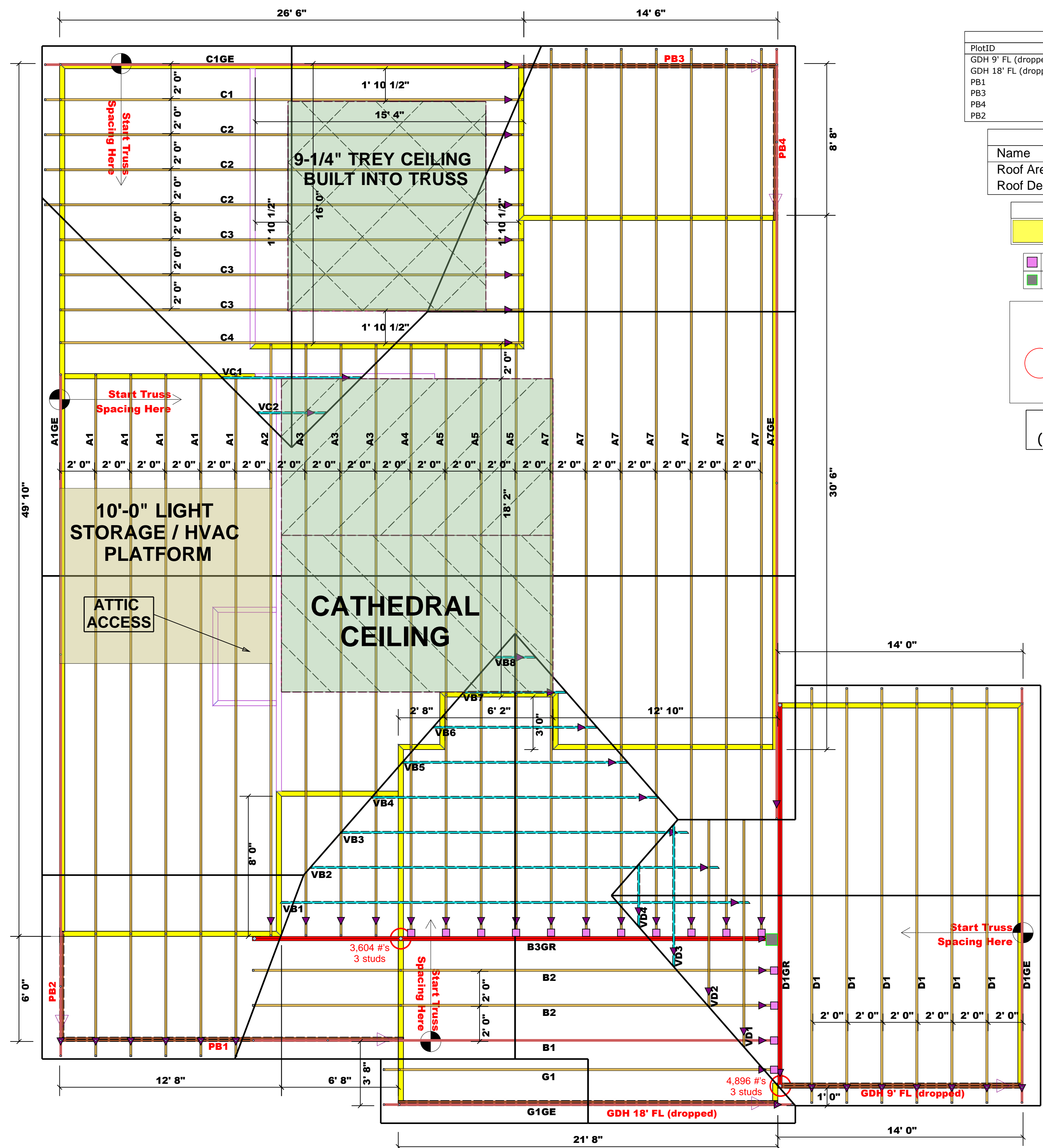

## Truss Placement Plan

SCALE: 1/4" = 1'-0"



Client: WEAVER  
 Project:  
 Address:

Date: 2/14/2024  
 Input by: Lenny Norris  
 Job Name: LINDSAY B 3-CAR  
 Project #:

**GDH9' 3-car Kerto-S LVL 1.750" X 11.875" 2-Ply - PASSED**

Level: Level

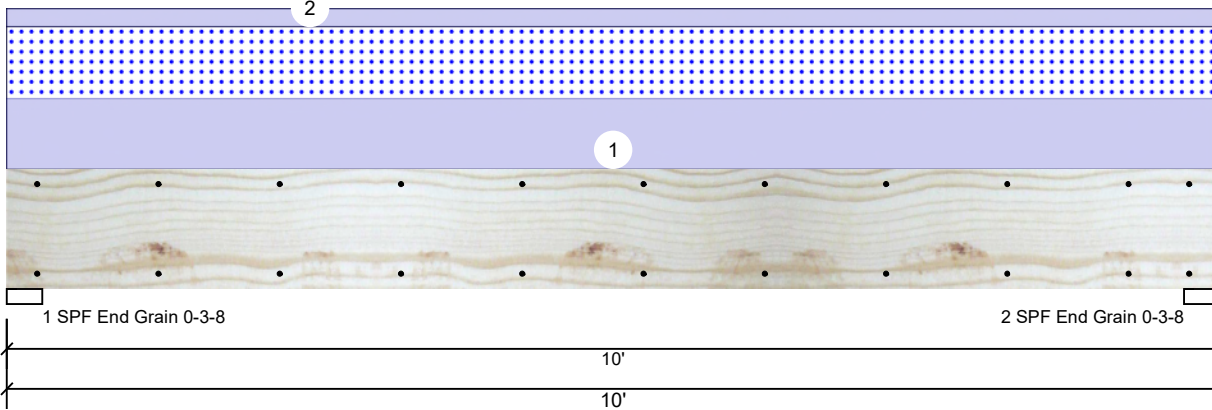

**Member Information**

Type:	Girder	Application:	Floor
Plies:	2	Design Method:	ASD
Moisture Condition:	Dry	Building Code:	IBC/IRC 2015
Deflection LL:	480	Load Sharing:	No
Deflection TL:	360	Deck:	Not Checked
Importance:	Normal - II		
Temperature:	Temp <= 100°F		

**Reactions UNPATTERNED lb (Uplift)**

Brg	Direction	Live	Dead	Snow	Wind	Const
1	Vertical	0	1511	1165	0	0
2	Vertical	0	1511	1165	0	0

**Bearings**

Bearing	Length	Dir.	Cap.	React D/L lb	Total	Ld. Case	Ld. Comb.
1 - SPF End Grain	3.500"	Vert	26%	1511 / 1165	2676	L	D+S
2 - SPF End Grain	3.500"	Vert	26%	1511 / 1165	2676	L	D+S

**Analysis Results**

Analysis	Actual	Location	Allowed	Capacity	Comb.	Case
Moment	6091 ft-lb	5'	22897 ft-lb	0.266 (27%)	D+S	L
Unbraced	6091 ft-lb	5'	9721 ft-lb	0.627 (63%)	D+S	L
Shear	2000 lb	1'3 3/8"	10197 lb	0.196 (20%)	D+S	L
LL Defl inch	0.052 (L/2209)	5'	0.239 (L/480)	0.217 (22%)	S	L
TL Defl inch	0.119 (L/962)	5'	0.318 (L/360)	0.374 (37%)	D+S	L

**Design Notes**

- 1 Provide support to prevent lateral movement and rotation at the end bearings. Lateral support may also be required at the interior bearings by the building code.
- 2 Fasten all plies using 2 rows of 10d Box nails (.128x3") at 12" o.c. Maximum end distance not to exceed 6".
- 3 Refer to last page of calculations for fasteners required for specified loads.
- 4 Girders are designed to be supported on the bottom edge only.
- 5 Top loads must be supported equally by all plies.
- 6 Top must be laterally braced at end bearings.
- 7 Bottom must be laterally braced at end bearings.
- 8 Lateral slenderness ratio based on single ply width.

ID	Load Type	Location	Trib Width	Side	Dead 0.9	Live 1	Snow 1.15	Wind 1.6	Const. 1.25	Comments
1	Uniform			Top	233 PLF	0 PLF	233 PLF	0 PLF	0 PLF	D1 TRUSS
2	Uniform			Top	60 PLF	0 PLF	0 PLF	0 PLF	0 PLF	FRAME DOWN WALL
	Self Weight				9 PLF					

**Notes**

Calculated Structured Designs is responsible only of the structural adequacy of this component based on the design criteria and loadings shown. It is the responsibility of the customer and/or the contractor to ensure the component suitability of the intended application, and to verify the dimensions and loads.

**Lumber**

1. Dry service conditions, unless noted otherwise
2. LVL not to be treated with fire retardant or corrosive

**Handling & Installation**

1. LVL beams must not be cut or drilled
2. Refer to manufacturer's product information regarding installation requirements, multi-ply fastening details, beam strength values, and code approvals
3. Damaged Beams must not be used
4. Design assumes top edge is laterally restrained
5. Provide lateral support at bearing points to avoid lateral displacement and rotation

6. For flat roofs provide proper drainage to prevent ponding

This design is valid until 6/28/2026

**Manufacturer Info**

Metsä Wood  
 301 Merritt 7 Building, 2nd Floor  
 Norwalk, CT 06851  
 (800) 622-5850  
[www.metsawood.com/us](http://www.metsawood.com/us)

Comtech, Inc.  
 1001 S. Reilly Road, Suite #639  
 Fayetteville, NC  
 USA  
 28314  
 910-864-TRUS



**GDH18' Kerto-S LVL 1.750" X 14.000" 2-Ply - PASSED**

Level: Level

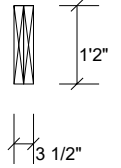
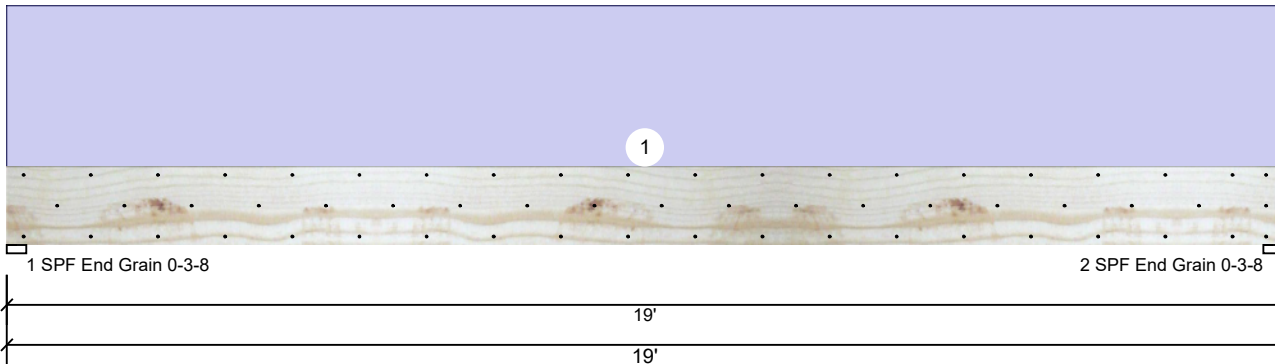

**Member Information**

Type:	Girder	Application:	Floor
Plies:	2	Design Method:	ASD
Moisture Condition:	Dry	Building Code:	IBC/IRC 2015
Deflection LL:	480	Load Sharing:	No
Deflection TL:	360	Deck:	Not Checked
Importance:	Normal - II		
Temperature:	Temp <= 100°F		

**Reactions UNPATTERNED lb (Uplift)**

Brg	Direction	Live	Dead	Snow	Wind	Const
1	Vertical	0	2003	0	0	0
2	Vertical	0	2003	0	0	0

**Bearings**

Bearing	Length	Dir.	Cap.	React D/L lb	Total	Ld. Case	Ld. Comb.
1 - SPF End Grain	3.500"	Vert	19%	2003 / 0	2003	Uniform	D
2 - SPF End Grain	3.500"	Vert	19%	2003 / 0	2003	Uniform	D

**Analysis Results**

Analysis	Actual	Location	Allowed	Capacity	Comb.	Case
Moment	9063 ft-lb	9'6"	24299 ft-lb	0.373 (37%)	D	Uniform
Unbraced	9063 ft-lb	9'6"	9077 ft-lb	0.998 (100%)	D	Uniform
Shear	1709 lb	1'5 1/2"	9408 lb	0.182 (18%)	D	Uniform
LL Defl inch	0.000 (L/999)	0	999.000 (L/0)	0.000 (0%)		
TL Defl inch	0.372 (L/599)	9'6 1/16"	0.618 (L/360)	0.601 (60%)	D	Uniform

**Design Notes**

- 1 Provide support to prevent lateral movement and rotation at the end bearings. Lateral support may also be required at the interior bearings by the building code.
- 2 Fasten all plies using 3 rows of 10d Box nails (.128x3") at 12" o.c. Maximum end distance not to exceed 6".
- 3 Refer to last page of calculations for fasteners required for specified loads.
- 4 Girders are designed to be supported on the bottom edge only.
- 5 Top loads must be supported equally by all plies.
- 6 Top must be laterally braced at a maximum of 12'3 3/4" o.c.
- 7 Bottom must be laterally braced at end bearings.
- 8 Lateral slenderness ratio based on single ply width.

ID	Load Type	Location	Trib Width	Side	Dead 0.9	Live 1	Snow 1.15	Wind 1.6	Const. 1.25	Comments
1	Uniform			Top	200 PLF	0 PLF	0 PLF	0 PLF	0 PLF	FRAME DOWN WALL & GABLE
	Self Weight				11 PLF					

**Notes**

Calculated Structured Designs is responsible only of the structural adequacy of this component based on the design criteria and loadings shown. It is the responsibility of the customer and/or the contractor to ensure the component suitability of the intended application, and to verify the dimensions and loads.

**Lumber**

1. Dry service conditions, unless noted otherwise
2. LVL not to be treated with fire retardant or corrosive chemicals

**Handling & Installation**

1. LVL beams must not be cut or drilled
2. Refer to manufacturer's product information regarding installation requirements, multi-ply fastening details, beam strength values, and code approvals
3. Damaged Beams must not be used
4. Design assumes top edge is laterally restrained
5. Provide lateral support at bearing points to avoid lateral displacement and rotation

6. For flat roofs provide proper drainage to prevent ponding

This design is valid until 6/28/2026

**Manufacturer Info**

Metsä Wood  
 301 Merritt 7 Building, 2nd Floor  
 Norwalk, CT 06851  
 (800) 622-5850  
[www.metsawood.com/us](http://www.metsawood.com/us)

Comtech, Inc.  
 1001 S. Reilly Road, Suite #639  
 Fayetteville, NC  
 USA  
 28314  
 910-864-TRUS

