

ELEVATION NOTES:
 GRADE ELEVATIONS SHOWN DO NOT NECESSARILY REFER TO THIS OR ANY OTHER LOT. THEY ARE FOR DIAGNOSTIC PURPOSES ONLY AND MAY VARY. BUILDER IS RESPONSIBLE FOR ADAPTING THIS PLAN TO SUIT THE EXISTING TOPOGRAPHY OF THE SITE.
 ROOF VENTILATION TO BE DETERMINED BY BUILDER AS PER CODE.
 ALL EGRESS OR RESCUE WINDOWS FROM SLEEPING ROOMS MUST HAVE A MIN. NET CLEAR OPENING OF 4.0 SQ FT. THE MIN NET CLEAR OPENING HEIGHT DIMENSION SHALL BE 27". THE MIN NET CLEAR OPENING WIDTH SHALL BE 20".
 EACH EGRESS WINDOW FROM SLEEPING ROOMS MUST HAVE A SILL HGT. OF NO MORE THAN 44" FROM THE FLOOR. ALL WINDOW SIZES ARE NOMINAL AND ARE TO BE VERIFIED WITH MANUFACTURER FOR AVAILABILITY AND CONFORMITY TO STATE AND LOCAL CODE REQUIREMENTS.
 PORCHES, BALCONIES, OR RAISED FLOOR SURFACES LOCATED MORE THAN 30" ABOVE THE FLOOR OR GRADE BELOW SHALL HAVE GUARDRAILS NOT LESS THAN 37" IN HEIGHT.

I ASSUME NO RESPONSIBILITY FOR ANY DISTANCES AFTER START OF CONSTRUCTION.
 CONTRACTOR/BUILDER SHALL CONSULT WITH HOME OWNER ON ALL INTERIOR AND EXTERIOR HOLDINGS, TRIMS, COLORS, FINISHES, CABINET LAYOUTS, AND MANUFACTURERS BEFORE CONSTRUCTION BEGINS.
 ALL BEAMS AND FRAMING MEMBERS ARE SIZED BY OTHERS.

1.1 This plan has been drawn to comply with the 2018 NC Building Code

- 1.2 Minimum Design Loads for Building and Other Structures ASCE 7-95
- 2 Roof Dead Load 115 P&F
- 3 Roof Live Load 20 P&F
- 4 Typical Floor Dead Load 10 P&F
- 5 Floor Live Loads
 - 5.1 Rooms other than sleeping rooms 40 P&F
 - 5.2 Sleeping Rooms 30 P&F
 - 5.3 Stairs 40 P&F
 - 5.4 Decks 40 P&F
 - 5.5 Exterior Balconies 60 P&F
- 6 Wind Loads
 - 6.1 Ultimate Design Wind Speeds 15 MPH
 - 6.2 Wind Importance Factor, I_w 1.00
 - 6.3 Exposure B
 - 6.4 Walls (Component and Cladding) 25 P&F
 - 6.5 Roofs (Component and Cladding)
 - 6.5.1 Roof Slopes 2.25/12 to 1/12 34.8 P&F
 - 6.5.2 Roof Slopes 1/12 to 12/12 21 P&F

It is the sole responsibility of the Contractor and/or Builder to conform to all standards, provisions, requirements, methods of construction and uses of materials provided in buildings and/or structures as required by NC Uniform Building Code, Local Agencies and in accordance with good engineering practices. Verify all dimensions prior to construction.

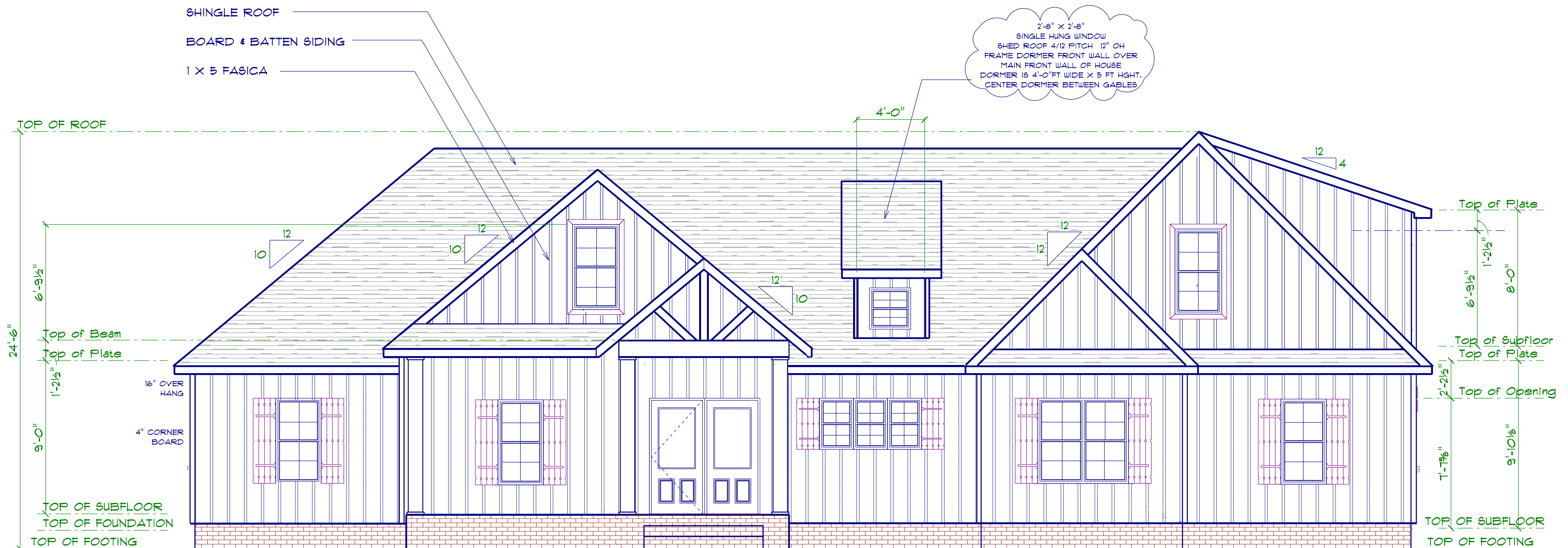

FRONT ELEVATION
 SCALE: 1" = 1/4"

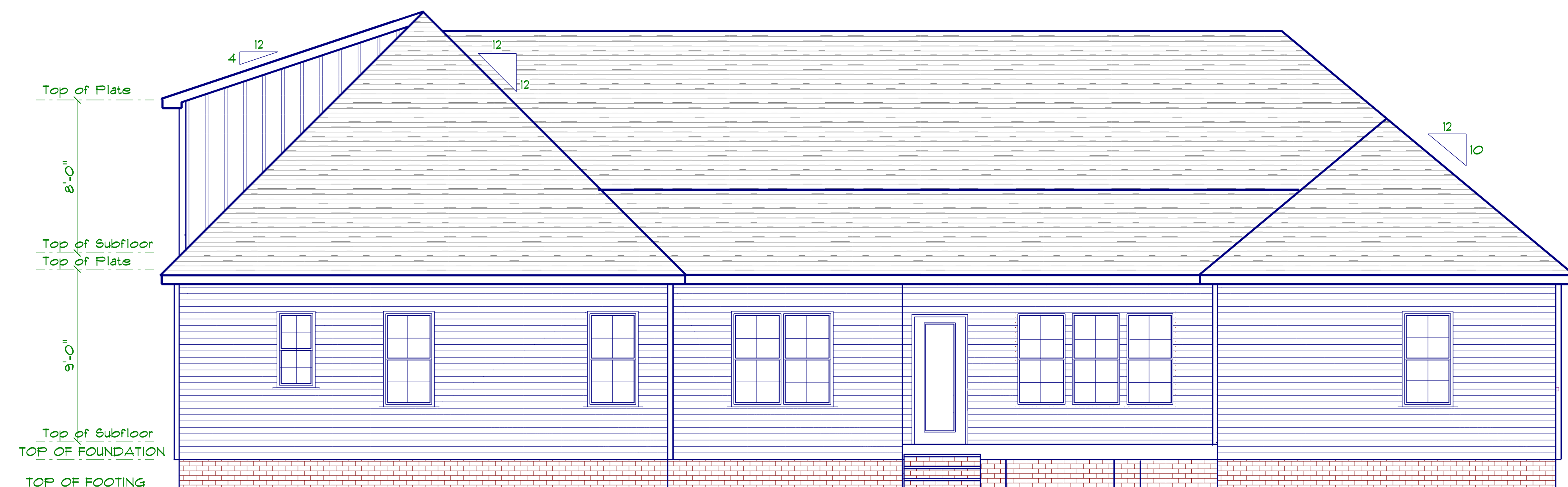

REAR ELEVATION
 SCALE: 1" = 1/4"

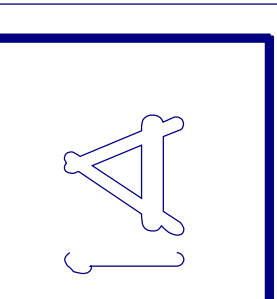

Diane Rives Design
 6205 Mockingbird Lane
 Sanford, NC, 27332
 919-710-0353
 g@harnettcounty.net
DRD

SCALE: 1" = 1/4"
 DRAWN BY:
 DATE: 1/10/2024

CRH HOMES

THE ABBEY-BRIDGES
 RIGHT GARAGE

FRONT & REAR
 ELEVATIONS

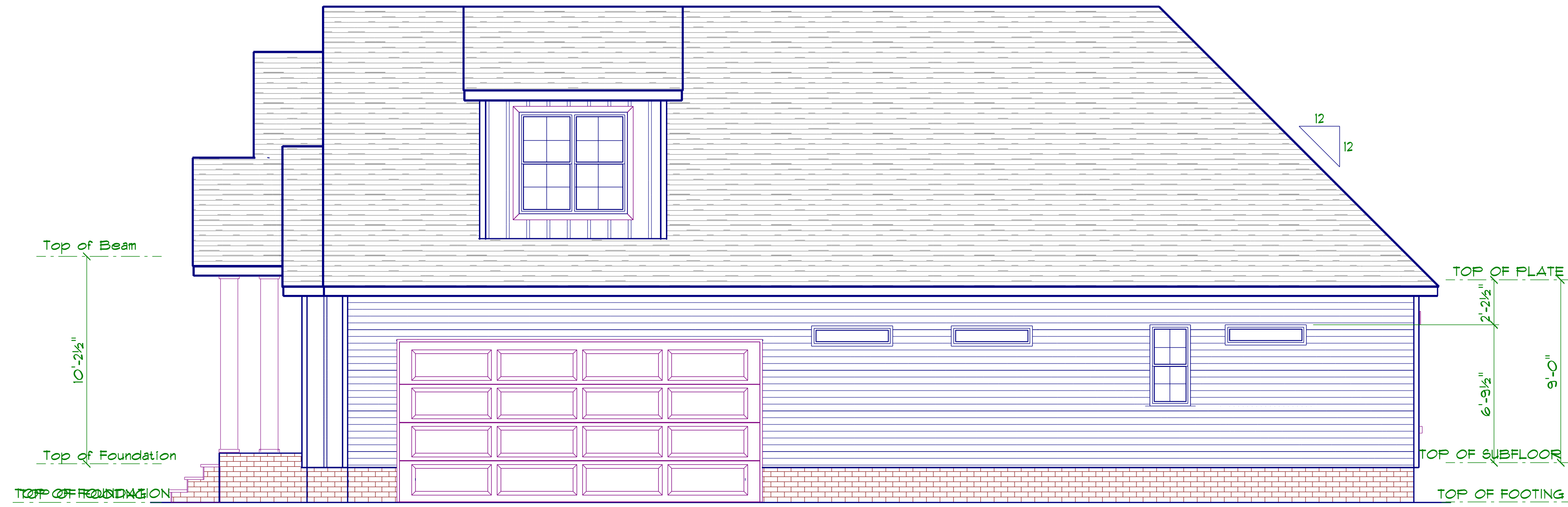

RIGHT ELEVATION
SCALE: 1" = 1/4"

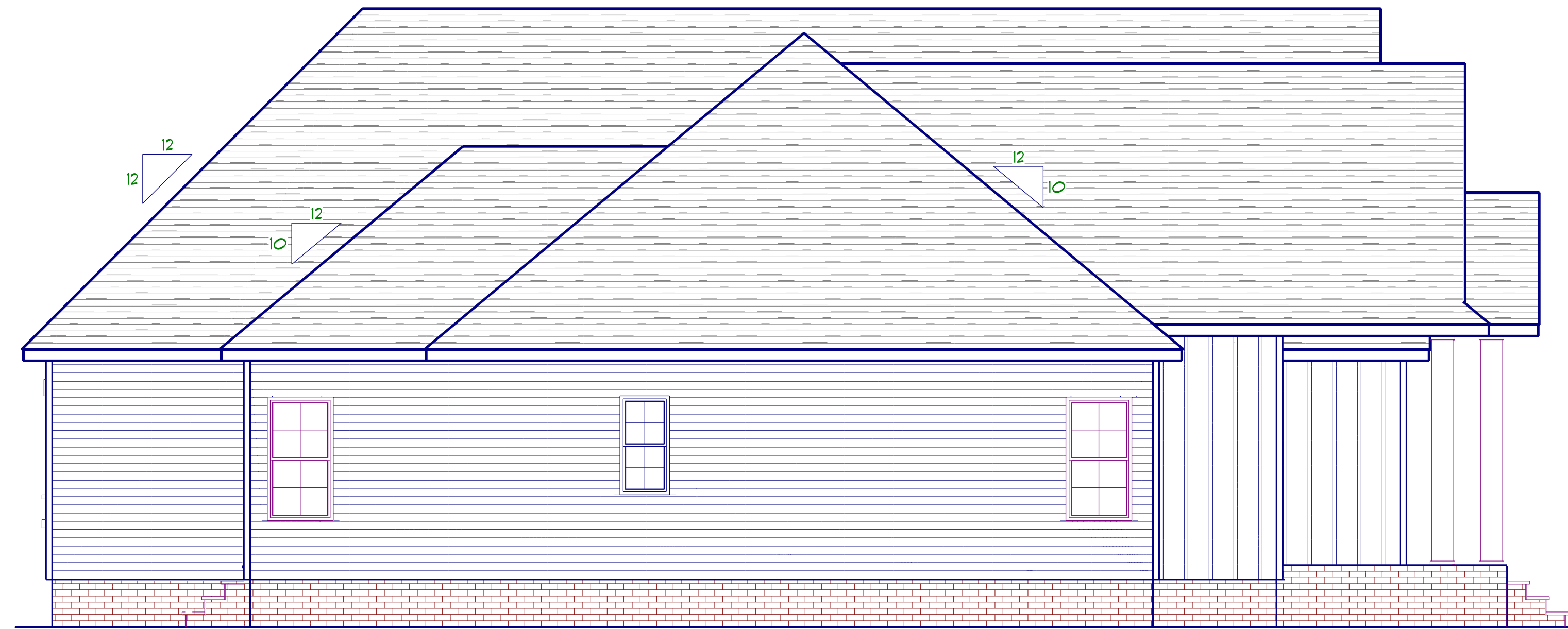

LEFT ELEVATION
SCALE: 1" = 1/4"

TYPICAL WALL: 8" BLOCK W/ 16" X 10" FOOTING
 BRICK 4" BLOCK W/ 16" X 10" FOOTING
 3- 2 X 10'S GIRDER
 2 X 10'S 16" OC JOIST
 2- 2 X 10'S DBL JOIST

FOUNDATION NOTES:
 ALL FOOTINGS SHALL BEAR ON ORIGINAL UNDISTURBED SOIL.
 THE 28 DAY COMPRESSIVE STRENGTH OF ALL FOOTINGS IS 3000 PSI

PROVIDE WATER PROOFING AND PERIMETER DRAINS AS REQUIRED.

FOUNDATION CONCRETE MIX TO HAVE 1-1/2" MAX AGGREGATE SIZE. CONCRETE FILL MIX TO HAVE 1/2" MAX AGGREGATE SIZE.

FOOTING WIDTHS ARE BASED ON A LOAD-BEARING SOIL CAPACITY OF 2000 P/SI.

PROVIDE 6 MIL POLY VAPOR BARRIER TO COVER GROUND SURFACE IN CRAWL SPACE

ALL ANCHOR BOLTS TO BE 1/2" LONG, 1/2" DIA. A36 UNO ANCHOR BOLTS SHALL BE SPACE AT A MAX OF 6' OC AND NO MORE THAN 1' FROM EA CORNER.

Termite Soil Treatment: Treat entire slab area soil or crawl space surface before vapor barrier is installed and slab is poured with a state approved termiticide. Termiticide should be applied by a licensed and certified pest control professional by the state of North Carolina.

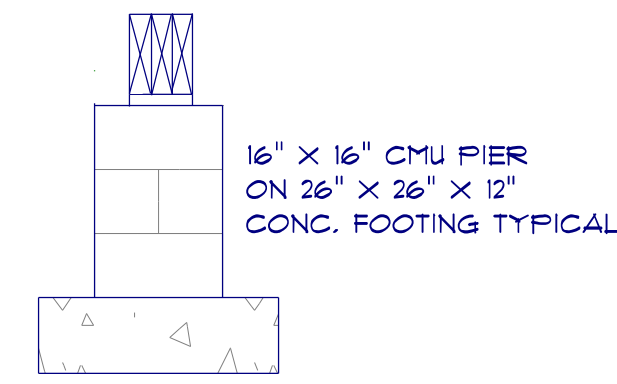

CONCRETE BLOCK PIER DETAIL
 NOT TO SCALE

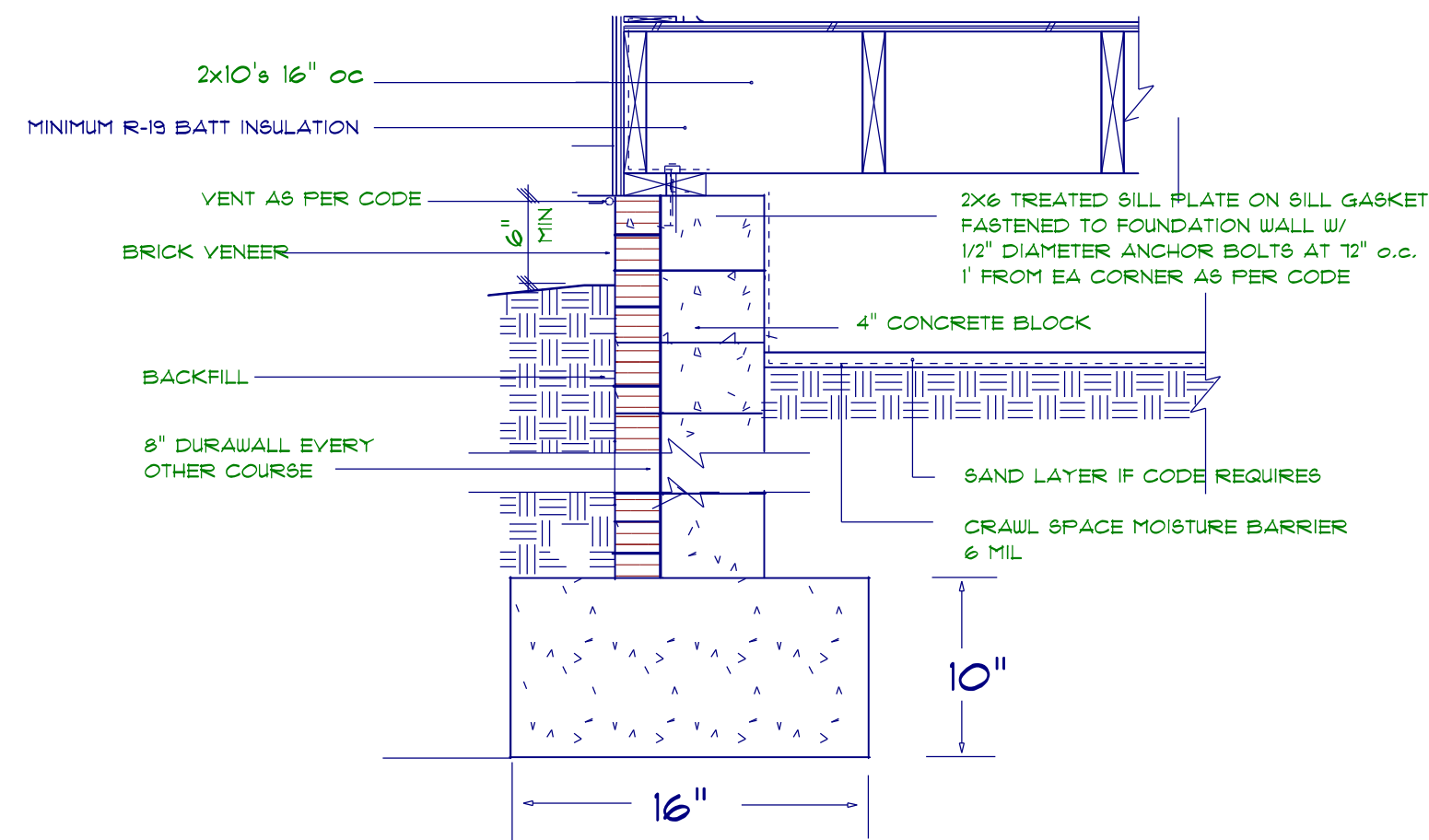

FOOTING & FOUNDATION DETAIL
 not to scale

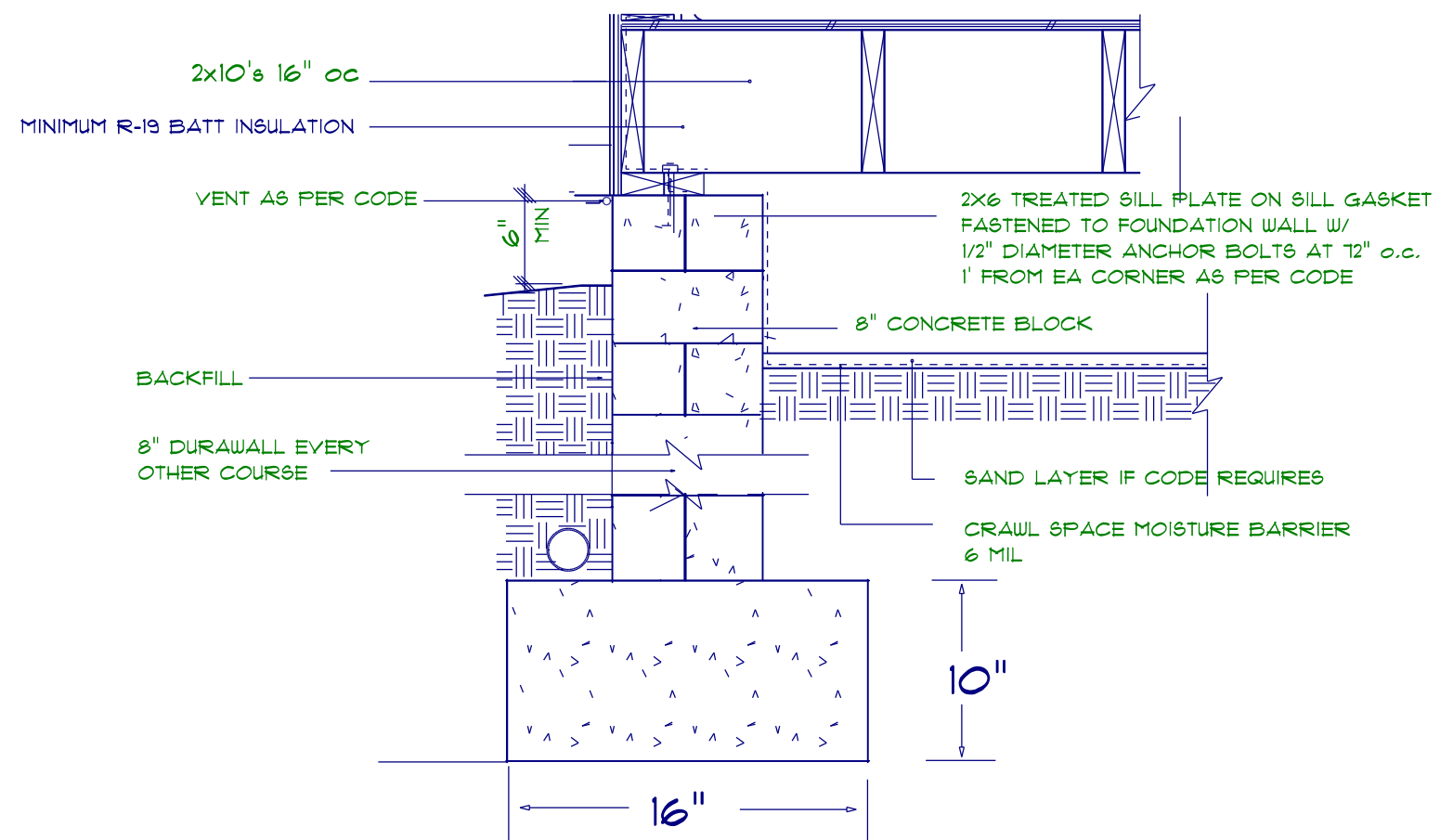

FOOTING & FOUNDATION DETAIL
 not to scale

FOUNDATION NUTS, BOLTS AND WASHER #6'-0" OC
 1'-0" FROM EACH CORNER

NOTE: DOUBLE BAND OVER FOUNDATION VENT.
 DO NOT SPLICE WITHIN 12" OF OPENING
 LEDGER JOIST OVER OPENING

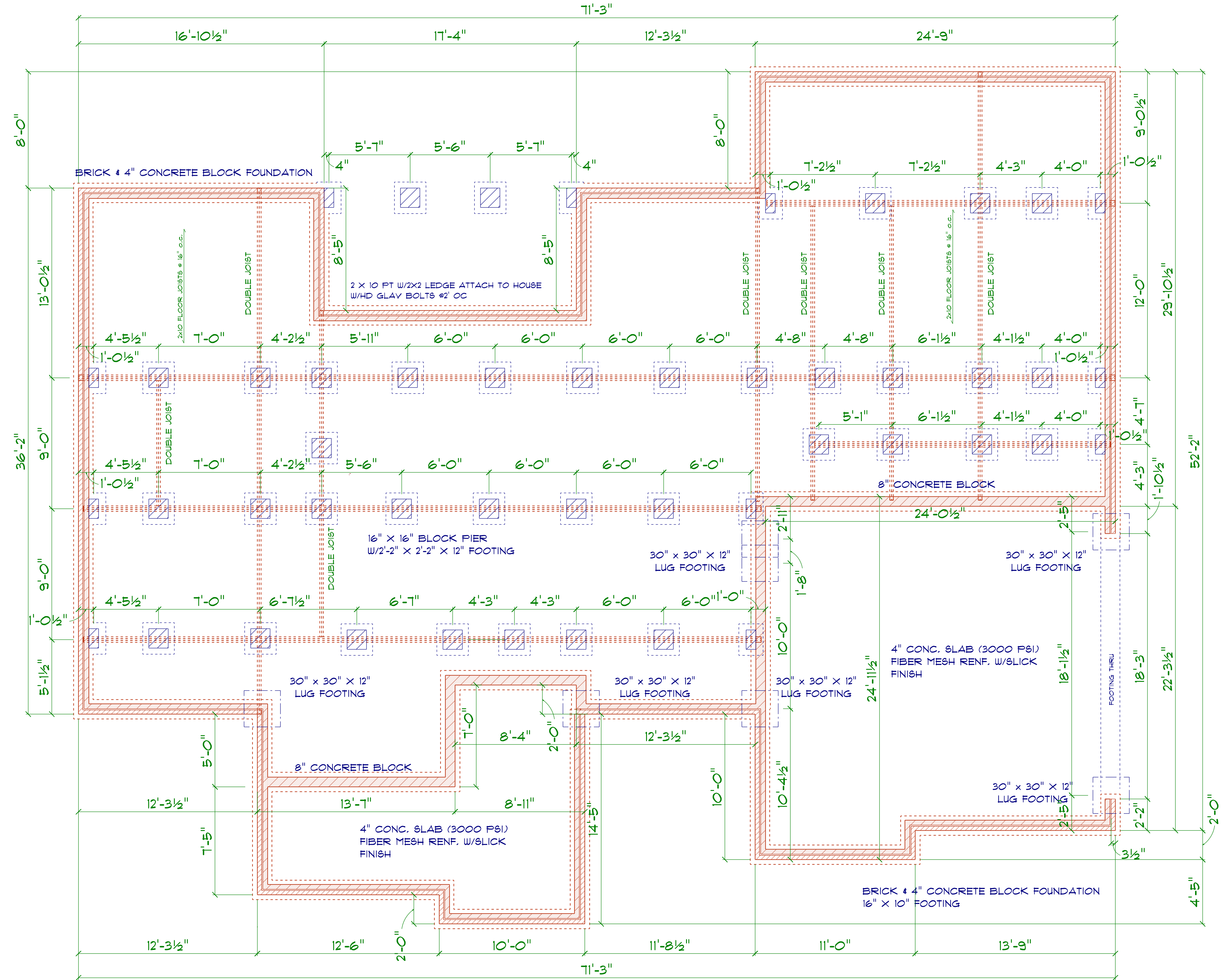

FOUNDATION PLAN

SCALE: 1" = 1/4"

GENERAL FRAMING NOTES:

ALL LUMBER IN CONTACT WITH CONCRETE OR MASONRY SHALL BE PRESSURE TREATED.

FRAMING LUMBER SHALL BE 8YP #2 GRADE AND/OR SPRUCE PINE FIR #1 AND/OR #2, KILN DRIED.

WHERE PRE-ENGINEERED JOISTS ARE USED, JOIST MANUFACTURER SHALL PROVIDE SHOP DRAWINGS, WHICH BEAR SEAL OF A N.C. ENGINEER.

STUDS AND JOISTS SHALL NOT BE CUT TO INSTALL PLUMBING OR WIRING WITHOUT ADDING METAL OR WOOD SIDE PANELS TO STRENGTHEN THE MEMBER TO ITS ORIGINAL CAPACITY.

NAIL MULTIPLE MEMBERS WITH 2 ROWS OF 16d NAILS STAGGERED 32" OC AN USE 3-16d NAILS 2" IN AT EACH END. DOUBLE ALL STUDS UNDER ROOF POST DOING UNO.

NAIL FLOOR JOISTS TO BILL PLATE WITH 8d TOE NAILS.

ALL EXPOSED FRAMING ON PORCHES AND DECKS SHALL BE PRESSURE TREATED.

PROVIDE WATERPROOFING AND DRAINS AS REQUIRED.

ALL FRAMING TO BE 16" OC UNO. WALL FRAMING DIMENSIONS ARE BASED ON 2 X 4 STUDS UNO, DOUBLE STUDS UNDER ALL HEADERS.

LVL'S AND TJI'S TO BE SIZED BY OTHERS

EXTERIOR WALLS IN LIVING AREAS ARE 2 X 4

OPENING SCHEDULE					
R.O. HEIGHT	R.O. WIDTH	LIBRARY NAME	COUNT	SIZE	
60-1/2"	32"	Window/Single Hung	1	2'-8" x 5'-0"	
60-1/2"	64-1/2"	Window/Single Hung	1	2'-8" x 5'-0" Dbl	

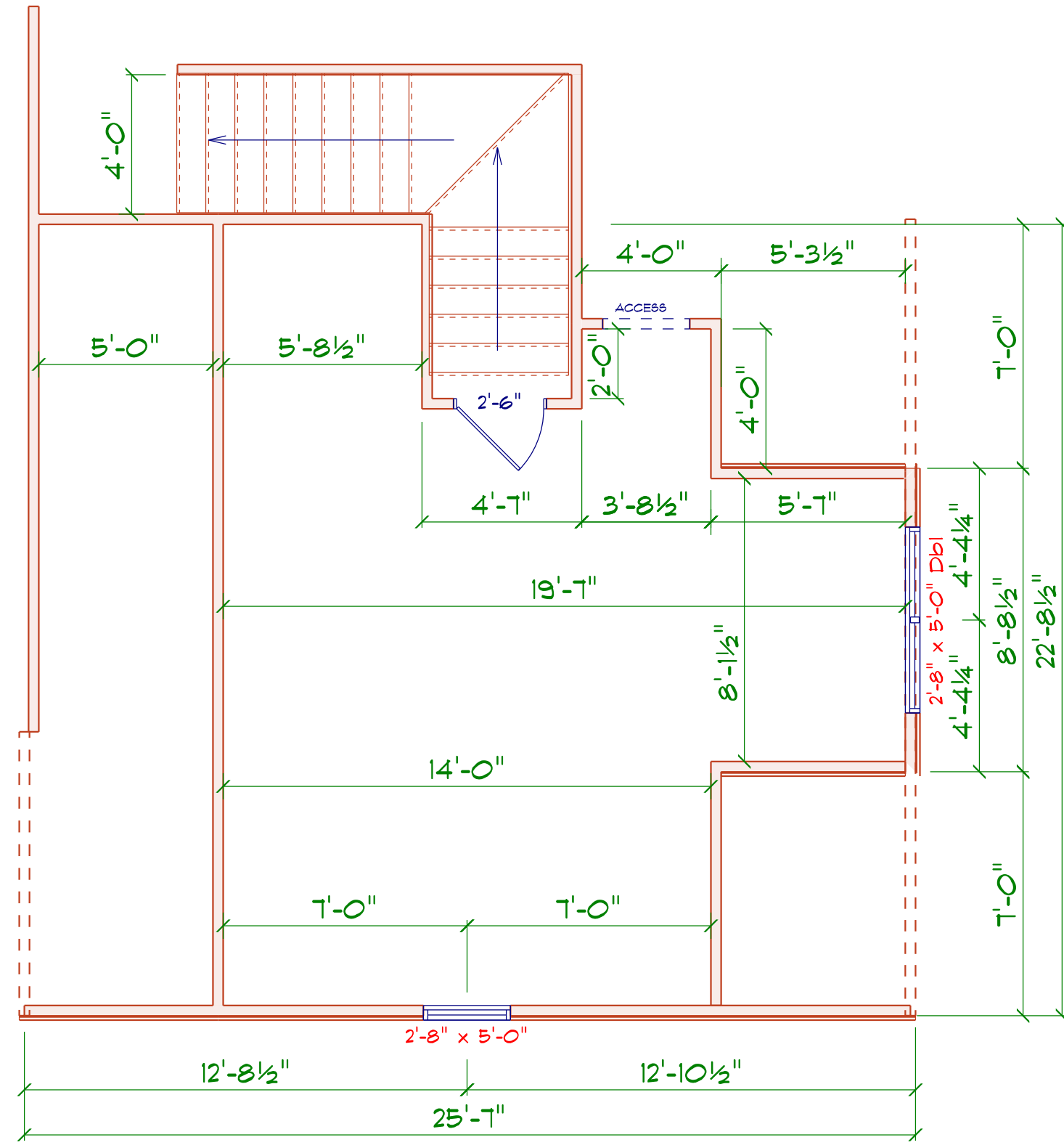

BONUS ROOM PLAN

SCALE: 1" = 1/4"

AREA SCHEDULE	
NAME	AREA
Bonus Room	350 sq. ft.

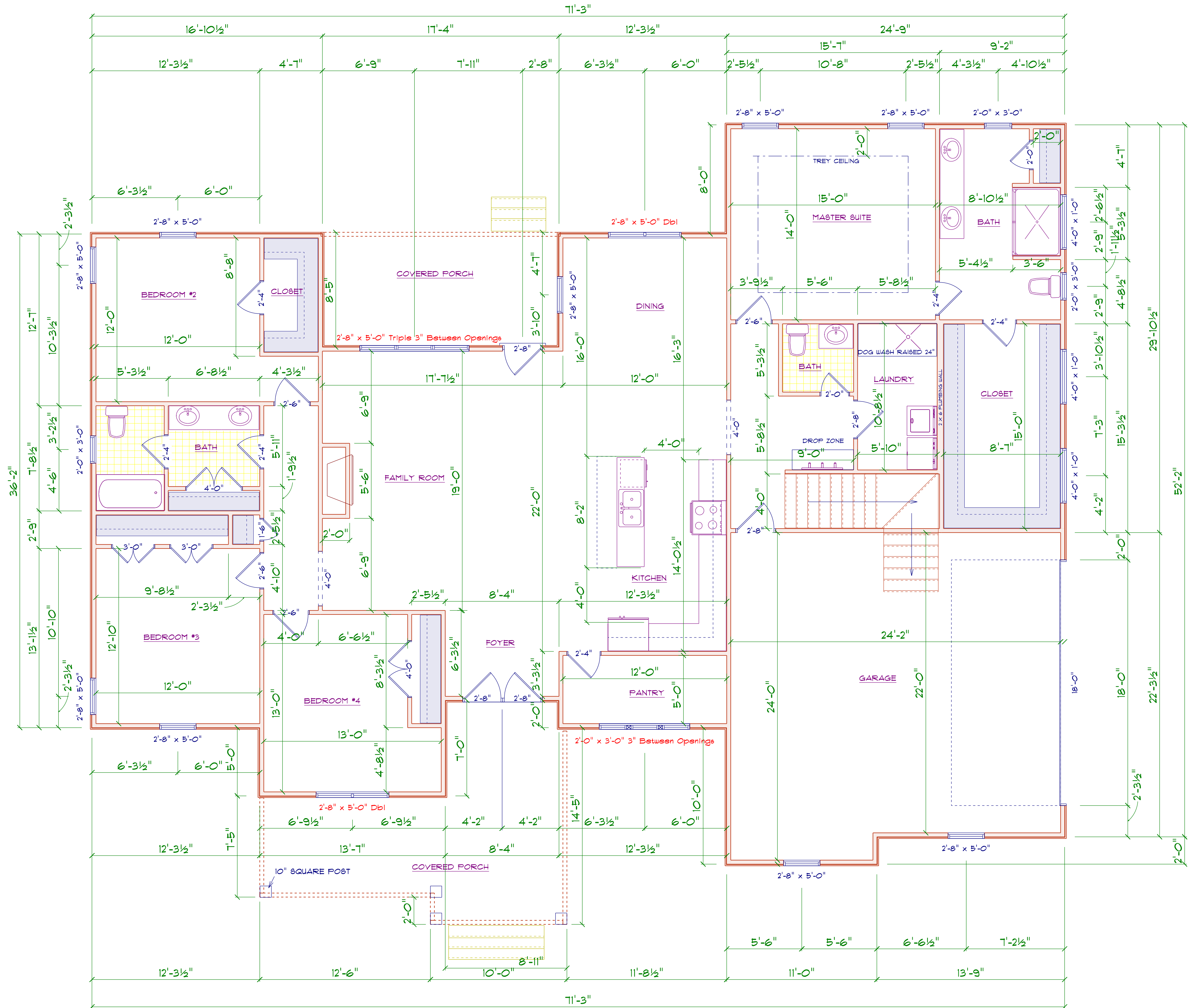

1ST FLOOR PLAN

SCALE: 1" = 1/4"

AREA SCHEDULE	
NAME	AREA
Heated	2332.9 sq. ft.
Garage	580.9 sq. ft.
Rear Covered Porch	145.9 sq. ft.
Covered Front Porch	235.4 sq. ft.

OPENING SCHEDULE					
SIZE	COUNT	LIBRARY NAME	R.O. WIDTH	R.O. HEIGHT	
4'-0" x 4'-0"	1	Window	48"	48"	
2'-0" x 3'-0"	1	Window/Single Hung	24"	36"	
2'-0" x 4'-0"	3	Window/Single Hung	24"	48"	
2'-8" x 5'-0" Triple	1	Window/Single Hung	96-1/2"	60-1/2"	
2'-8" x 5'-0"	11	Window/Single Hung	32"	60-1/2"	
2'-8" x 5'-0" Dbl	2	Window/Single Hung	64-1/2"	60-1/2"	

ROOF NOTES:
 TRUSSES, BRACINGS, BRIDGINGS AND CONNECTORS ARE TO BE DESIGNED BY THE TRUSS MANUFACTURER.
 IDENTIFY LUMBER BY OFFICIAL GRADE MARKINGS.
 DO NOT CUT OR REMOVE CHORDS OR OTHER TRUSS MEMBERS. DO NOT NOTCH OR DRILL TRUSS MEMBERS.
 WHERE PRE-ENGINEERED ROOF TRUSSES ARE USED, TRUSS MANUFACTURER SHALL PROVIDE SHOP DRAWINGS, WHICH BEAR SEAL OF A N. C. REGISTERED ENGINEER.

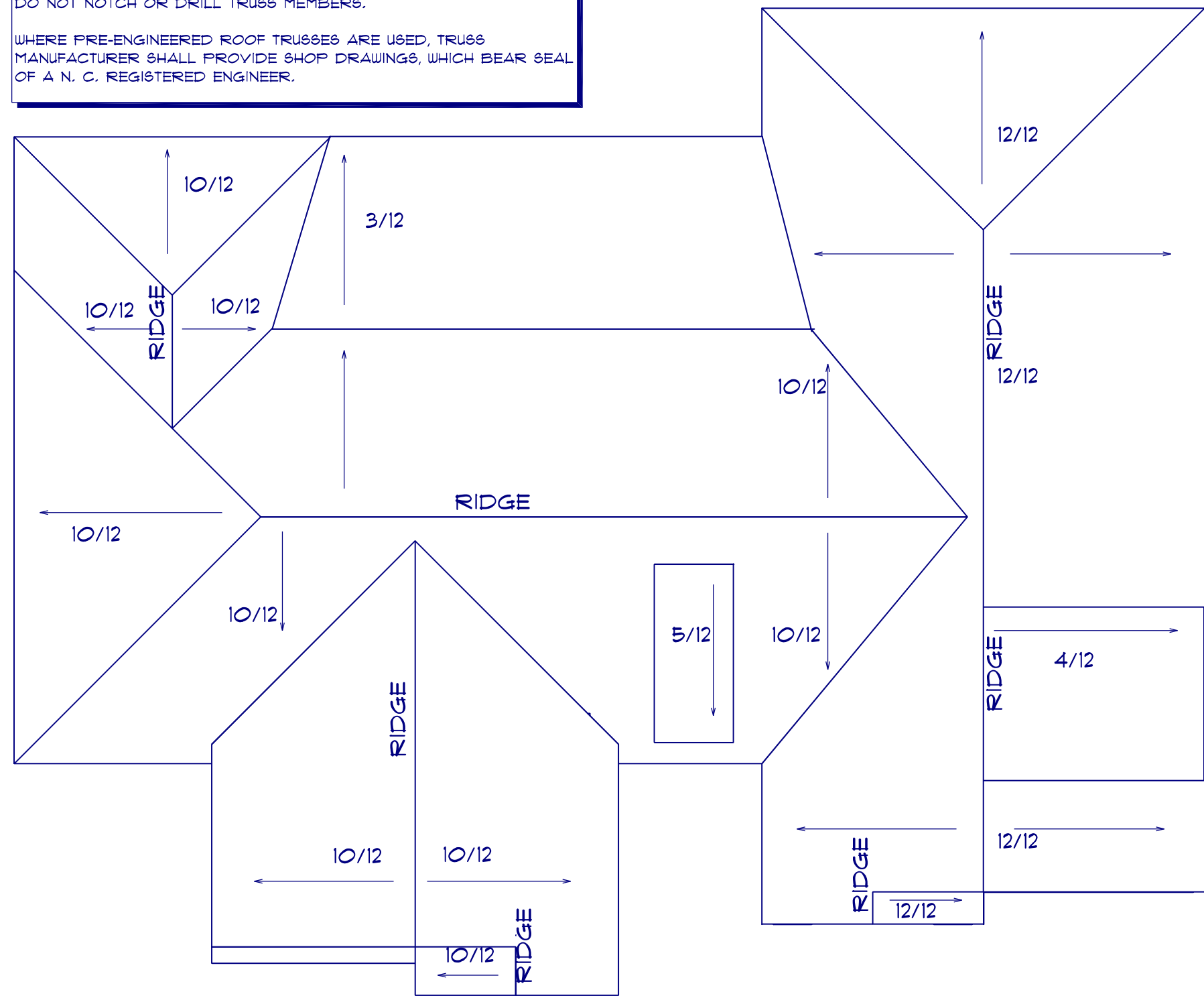

ROOF PLAN
 SCALE: 1" = 1/8"
 16" OVER HANG ALL

TYPICAL 2x4 SIDING EXTERIOR WALL:
 HORIZONTAL SIDING OR B4 B
 7/16" PLYWOOD SHEATHING
 2x4 STUDS @ 16" o.c.
 R15 BATT INSULATION
 1/2" DRYWALL
 TAPED & SANDED

TYPICAL 2x4 WALL:
 1/2" DRYWALL
 TAPED & SANDED
 2x4 STUDS @ 16" o.c.
 1/2" DRYWALL
 TAPED & SANDED

TYPICAL TRUSS ROOF:
 SHINGLES
 1/16" ROOFING PLYWOOD c/w
 1" CLIPS
 BLOCK & BRACE PER TRUSS MGR.
 PRE-ENGINEERED TRUSSES @ 24" o.c.
 2x4 TRUSS BRACING
 R38 BLOWN INSULATION
 5/8" CEILING BOARD
 TAPED & SANDED

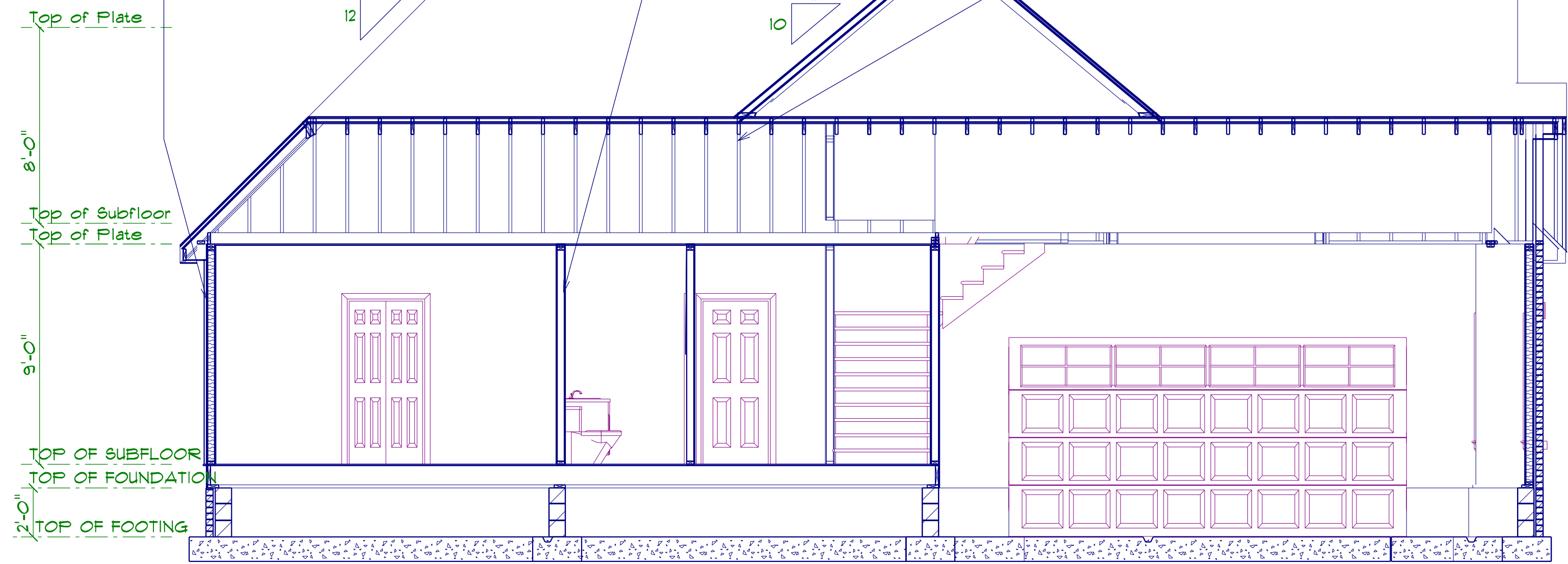

SECTION A
 SCALE: 1" = 1/4"

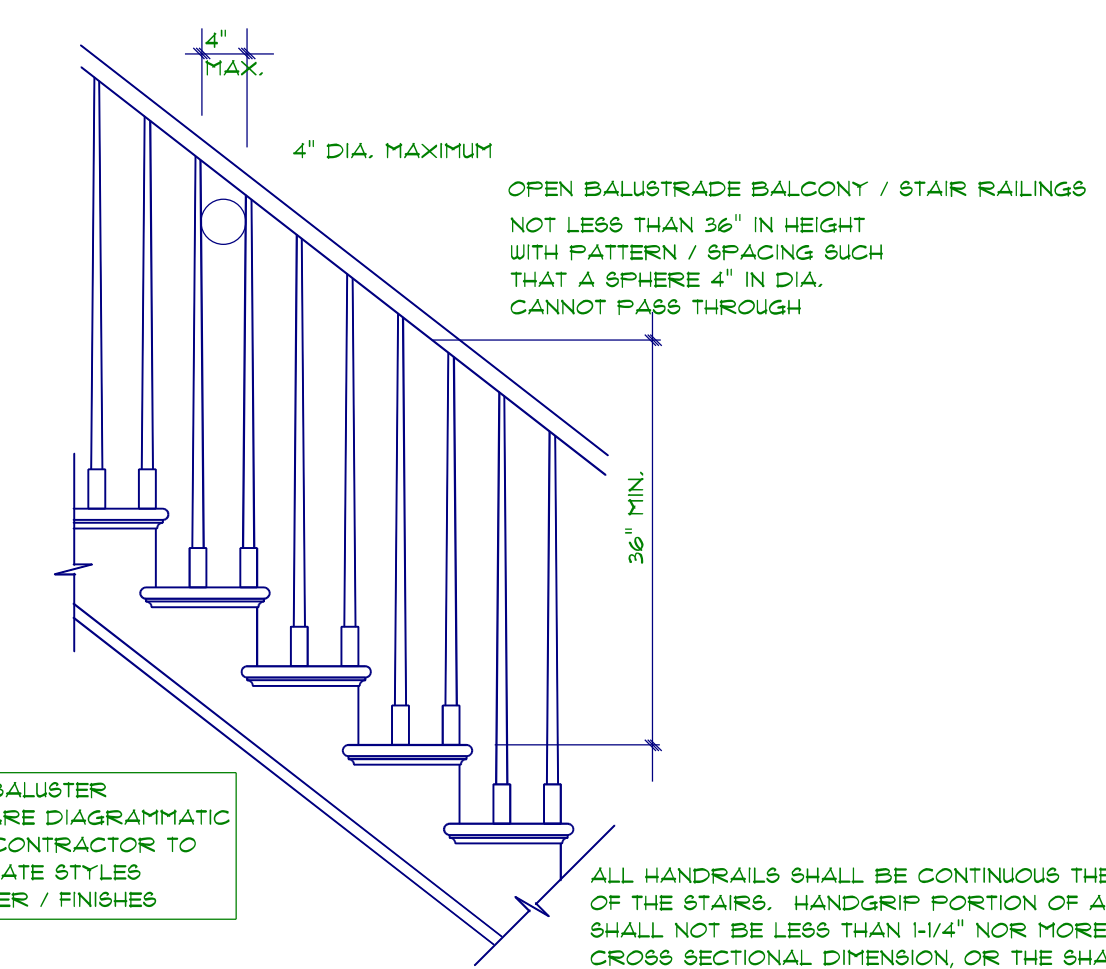

STAIR / BALUSTER STYLES ARE DIAGRAMMATIC ONLY - CONTRACTOR TO COORDINATE STYLES WITH OWNER / FINISHES

STAIR RAILING
 NOT TO SCALE

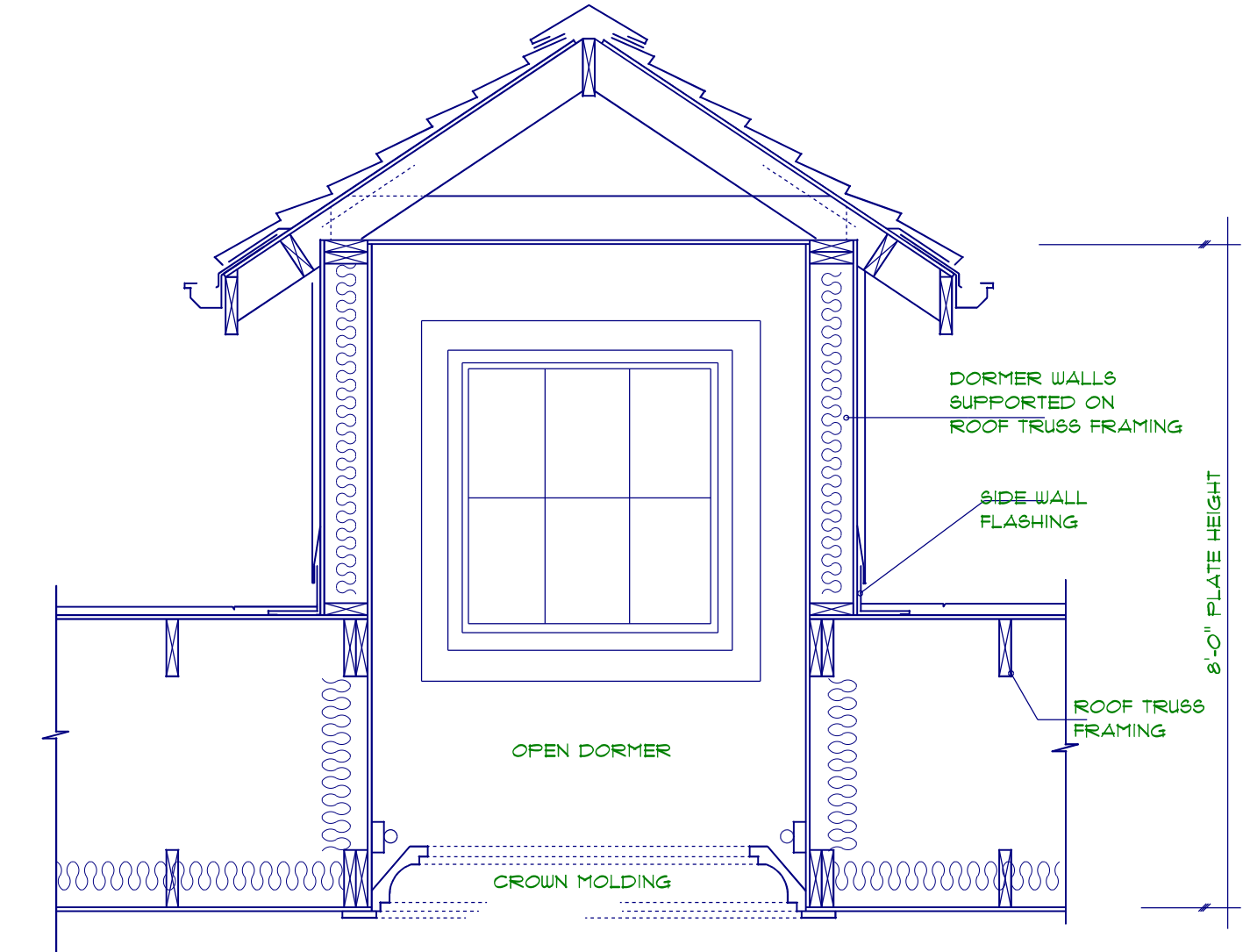

DORMER SECTION
 NOT TO SCALE

BA

DRD







Diana Rives Design
 6205 Mockingbird Lane
 Sanford, N.C. 27332
 919-700-0953
 gofunctionengineer.net

SCALE: 1" = 1/4"
 DRAWN BY:
 DATE: 1/10/2024

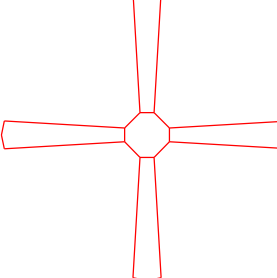
CRH HOMES

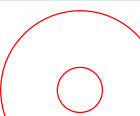
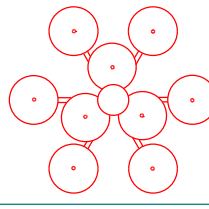
THE ABBEY-BRIDGES
 RIGHT GARAGE

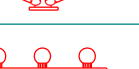
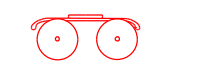
DETAIL SHEET

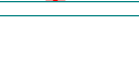
ELECTRICAL LEGEND		
ELECTRICAL	COUNT	SYMBOL
ceiling fan	3	
7" led	30	
10" led	8	
foyer light	1	
dinning room light	1	
coach light	2	
exterior over head	3	
flood light	4	
vanity bar light	5	
wall sconce		
pendant light		

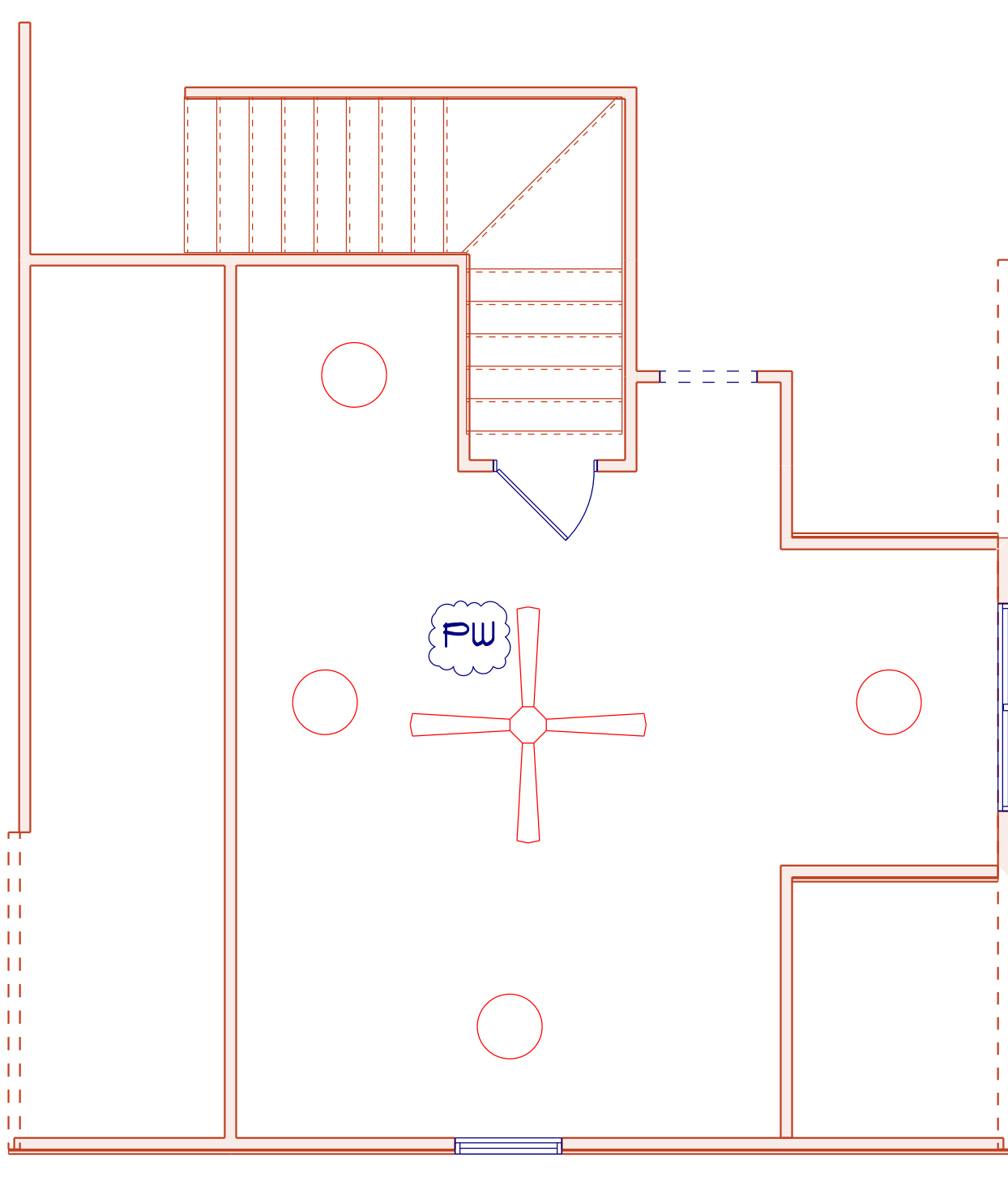

BONUS ROOM PLAN

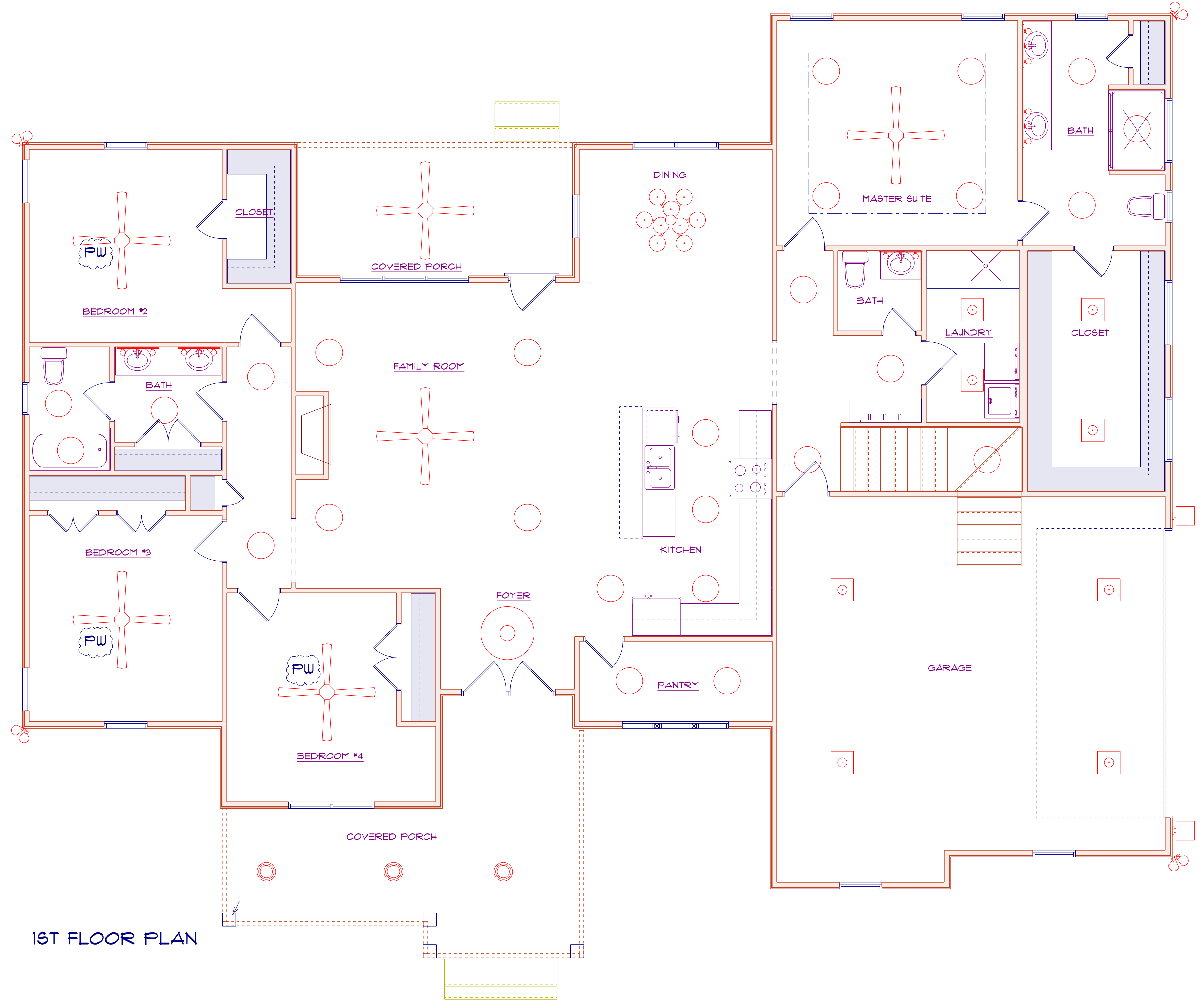

1ST FLOOR PLAN

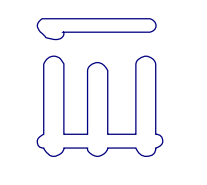

Diane Rives Designs
6205 Mockingbird Lane
Sanford, N.C. 27332
919-710-0959
g@lucamechanical.net

SCALE: 1" = 1/4"
DRAWN BY:
DATE: 1/10/2024

CRH HOMES

THE ABBEY-BRIDGES
RIGHT GARAGE

ELECTRICAL
LAYOUT

General Notes: ** CUTTING OR DRILLING OF COMPONENTS SHOULD NOT BE DONE WITHOUT CONTACTING COMPONENT SUPPLIER FIRST. CUSTOMER TAKES FULL RESPONSIBILITY FOR COMPONENTS IF CUT BEFORE AUTHORIZATION. ** ALL BEARING POINTS MUST BE INSTALLED PRIOR TO SETTING ANY COMPONENTS.

Revisions	
00/00/00	Name
00/00/00	Name
00/00/00	Name
00/00/00	Name
00/00/00	Name

THIS IS A TRUSS PLACEMENT DIAGRAM ONLY. These trusses are designed as individual components to be incorporated into the building design at the specification of the building designer. See individual design sheets for each truss design identified on the placement drawing. The building designer is responsible for temporary and permanent bracing of the roof and floor systems and for the overall structure. The design of the truss support structure including headers, beams, walls, and columns is the responsibility of the building designer. For general guidance regarding the bracing, consult "Bracing of Wood Truss" available from the Truss Plate Institute, 583 D'Onofrio Drive, Madison, WI 53179.



CRH Homes
Abby Plan
COMPONENT PLAN
PLACEMENT PLAN

Scale:	NTS
Date:	1/23/2024
Designer:	M. Finch
Project Number:	23030004
Sheet Number:	1/1

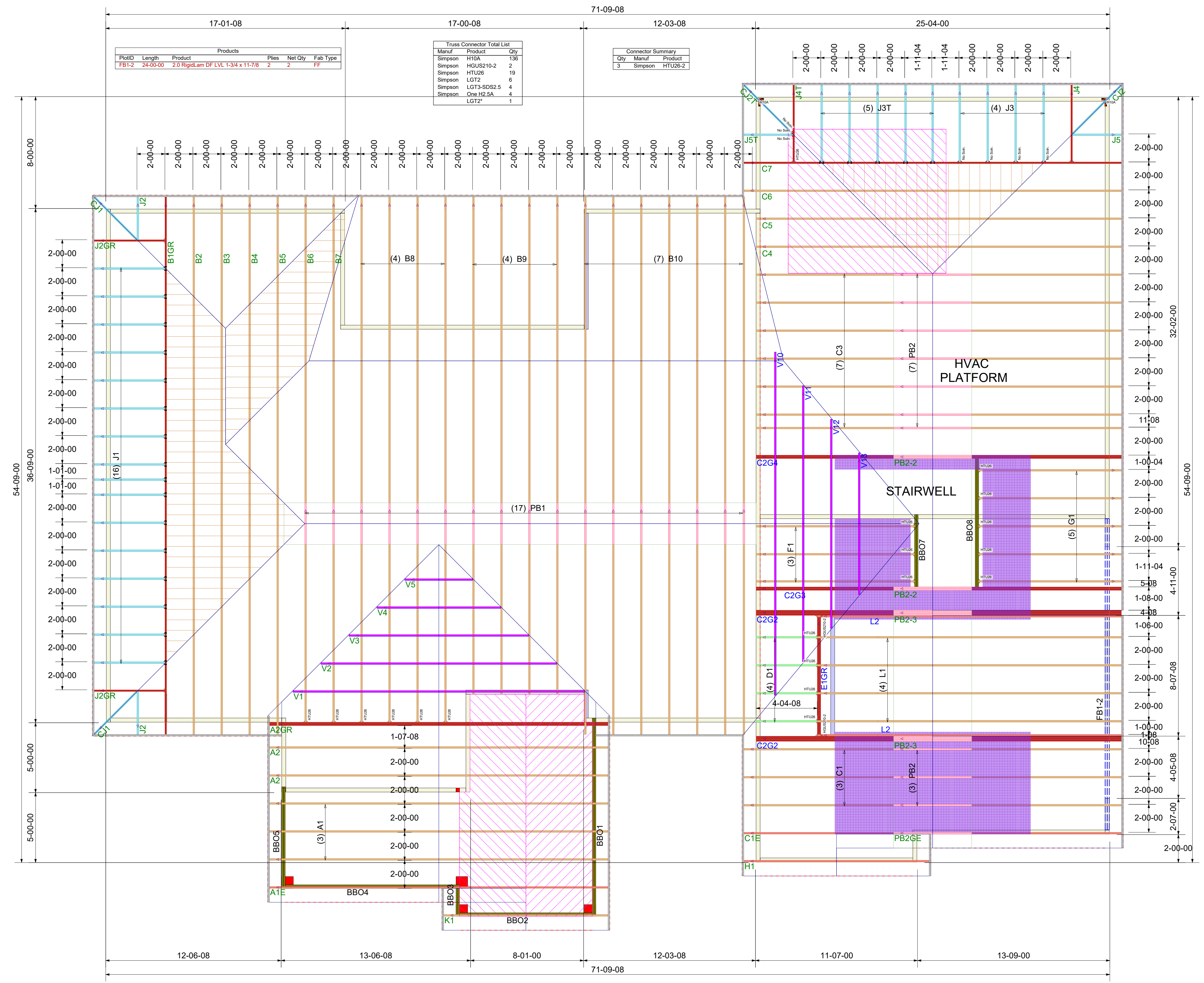

ProdID	Length	Product	Pieces	Net Qty	Fab Type
FB1-2	24-00-00	2.0 RigidLam DF LVL 1-3/4 x 11-7/8	2	2	FF

Manuf	Product	Qty
Simpson	HT10A	138
Simpson	HGUS210-2	2
Simpson	HTU26	19
Simpson	LGT2	6
Simpson	LGT3-SDS2.5	4
Simpson	One H2.5A	4
Simpson	LGT2"	1

Qty	Manuf	Product
3	Simpson	HTU26-2

** DAMAGED COMPONENTS SHOULD NOT BE INSTALLED UNLESS TOLD TO BY THE COMPONENT PLANT. **
** FRAMER MUST REFER TO PLANS WHILE SETTING COMPONENTS. **
** GIRDERS MUST BE FULLY CONNECTED TOGETHER PRIOR TO ADDING ANY LOADS. **
** TRUSS TO TRUSS CONNECTIONS ARE TOE-NAILED, UNLESS NOTED OTHERWISE. **
** DIMENSIONS ARE READ AS: FOOT-INCH-SIXTEENTH. **
** TRIANGULAR SYMBOL NEAR END OF TRUSS INDICATES LEFT END OF TRUSS AS SHOWN ON INDIVIDUAL TRUSS DRAWINGS. **
** PLUMBING DROPS NOTED ARE IN THE APPROXIMATE LOCATIONS PER PLAN. BUILDER TO VERIFY LOCATIONS BEFORE SETTING TRUSSES. **
** REFER TO FINAL TRUSS ENGINEERING SHEETS FOR PLY TO PLY CONNECTIONS. **

