

Job Ashby	Truss F1	Truss Type Floor	Qty 1	Ply 1	Job Reference (optional)
--------------	-------------	---------------------	----------	----------	--------------------------

Carter Components, Sanford, NC, user

Run: 8.53 S Mar 28 2022 Print: 8.530 S Mar 28 2022 MiTek Industries, Inc. Wed May 11 15:47:42

Page: 1

ID:KlbRyxbB5gb\_DSfStKSfDzHcyN-PW7wrVfzB1cZZD7p928c?MwIDkUJsU4APBQXskzHY0V

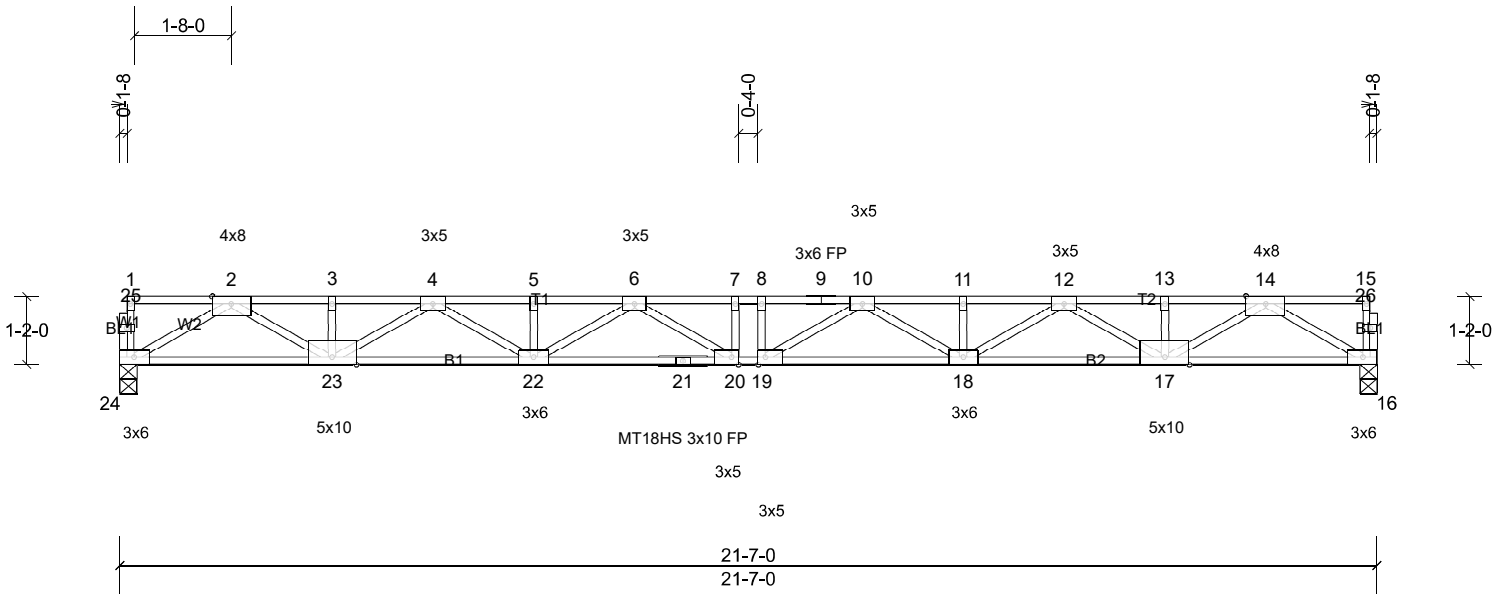

Scale = 1:39.6

Plate Offsets (X, Y): [19:0-1-8,Edge], [20:0-1-8,Edge]

Loading	(psf)	Spacing	2-0-0	CSI	DEFL	in	(loc)	l/defl	L/d	PLATES	GRIP	
TCLL	40.0	Plate Grip DOL	1.00	TC	0.79	Vert(LL)	-0.59	19-20	>433	360	MT18HS	244/190
TCDL	10.0	Lumber DOL	1.00	BC	0.60	Vert(CT)	-0.81	19-20	>315	240	MT20	244/190
BCLL	0.0	Rep Stress Incr	YES	WB	0.81	Horz(CT)	0.10	16	n/a	n/a		
BCDL	5.0	Code	IRC2018/TPI2014	Matrix-MSH								
											Weight: 111 lb	FT = 20%F, 11%E

#### LUMBER

TOP CHORD 2x4 SP No.2(flat)  
 BOT CHORD 2x4 SP 2400F 2.0E(flat)  
 WEBS 2x4 SP No.3(flat)  
 OTHERS 2x4 SP No.3(flat)

#### BRACING

TOP CHORD Structural wood sheathing directly applied or 3-2-2 oc purlins, except end verticals.  
 BOT CHORD Rigid ceiling directly applied or 10-0-0 oc bracing.

**REACTIONS** (lb/size) 16=1167/0-3-8, (min. 0-1-8), 24=1167/0-3-8, (min. 0-1-8)

**FORCES** (lb) - Max. Comp./Max. Ten. - All forces 250 (lb) or less except when shown.

TOP CHORD 2-3=-3323/0, 3-4=-3323/0, 4-5=-5288/0, 5-6=-5288/0, 6-7=-5993/0, 7-8=-5993/0, 8-9=-5993/0, 9-10=-5993/0, 10-11=-5288/0, 11-12=-5288/0, 12-13=-3323/0, 13-14=-3323/0  
 BOT CHORD 23-24=0/1861, 22-23=0/4460, 21-22=0/5801, 20-21=0/5801, 19-20=0/5993, 18-19=0/5801, 17-18=0/4460, 16-17=0/1861  
 WEBS 14-16=-2148/0, 2-24=-2148/0, 14-17=0/1707, 2-23=0/1707, 12-17=-1328/0, 4-23=-1328/0, 12-18=0/966, 4-22=0/966, 10-18=-598/0, 6-22=-598/0, 10-19=-223/557, 6-20=-223/557

#### NOTES

- 1) Unbalanced floor live loads have been considered for this design.
- 2) All plates are MT20 plates unless otherwise indicated.
- 3) All plates are 1.5x3 MT20 unless otherwise indicated.
- 4) The Fabrication Tolerance at joint 21 = 11%
- 5) This truss is designed in accordance with the 2018 International Residential Code sections R502.11.1 and R802.10.2 and referenced standard ANSI/TPI 1.
- 6) Required 2x6 strongbacks, on edge, spaced at 10-0-0 oc and fastened to each truss with 3-10d (0.131" X 3") nails. Strongbacks to be attached to walls at their outer ends or restrained by other means.

**LOAD CASE(S)** Standard

Job Ashby	Truss F1GE	Truss Type Floor Supported Gable	Qty 1	Ply 1	Job Reference (optional)
--------------	---------------	-------------------------------------	----------	----------	--------------------------

Carter Components, Sanford, NC, user

Run: 8.53 S Mar 28 2022 Print: 8.530 S Mar 28 2022 MiTek Industries, Inc. Wed May 11 15:47:43

Page: 1

ID:GgjBMddRcHriTmpr?IULkezHcyL-tjhI2rGcyLkQANI?jfrYaS5u8zfb7WJdrA5PAzHY0U

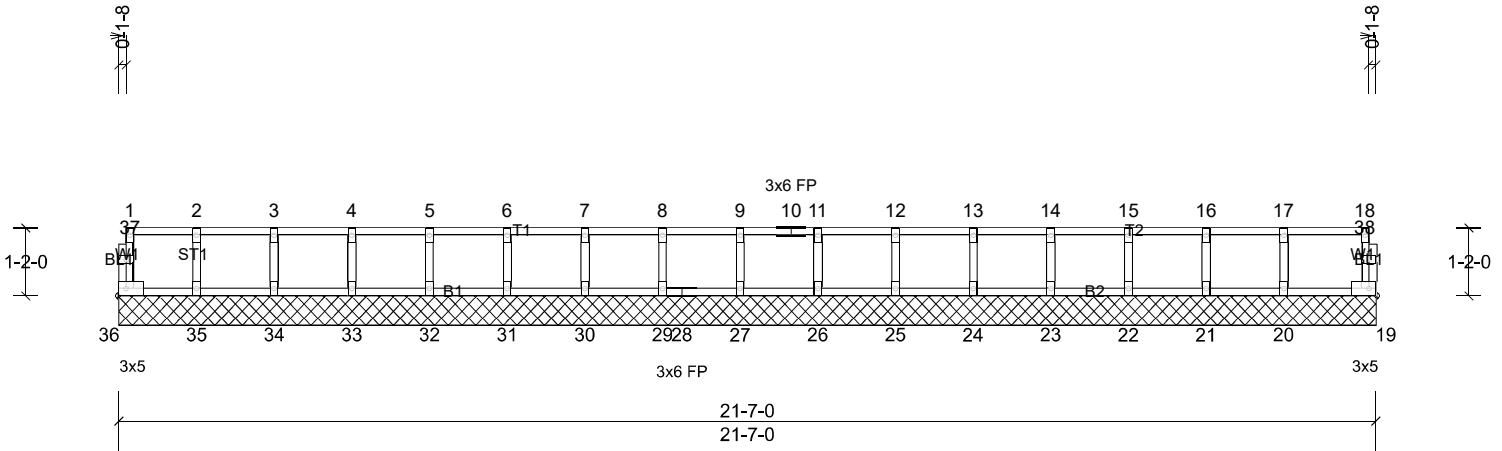

Scale = 1:39.6

Loading	(psf)	Spacing	2-0-0	CSI	DEFL	in	(loc)	l/defl	L/d	PLATES	GRIP	
TCLL	40.0	Plate Grip DOL	1.00	TC	0.09	Vert(LL)	n/a	-	n/a	999	MT20	244/190
TCDL	10.0	Lumber DOL	1.00	BC	0.02	Vert(TL)	n/a	-	n/a	999		
BCLL	0.0	Rep Stress Incr	YES	WB	0.03	Horiz(TL)	0.00	19	n/a	n/a		
BCDL	5.0	Code	IRC2018/TPI2014	Matrix-MR							Weight: 89 lb	FT = 20%F, 11%E

**LUMBER**

TOP CHORD 2x4 SP No.2(flat)  
 BOT CHORD 2x4 SP No.2(flat)  
 WEBS 2x4 SP No.3(flat)  
 OTHERS 2x4 SP No.3(flat)

**BRACING**

TOP CHORD Structural wood sheathing directly applied or 6-0-0 oc purlins, except end verticals.  
 BOT CHORD Rigid ceiling directly applied or 10-0-0 oc bracing.

**REACTIONS** All bearings 21-7-0.

(lb) - Max Grav All reactions 250 (lb) or less at joint(s) 19, 20, 21, 22, 23, 24, 25, 26, 27, 29, 30, 31, 32, 33, 34, 35, 36

**FORCES** (lb) - Max. Comp./Max. Ten. - All forces 250 (lb) or less except when shown.

**NOTES**

- All plates are 1.5x3 MT20 unless otherwise indicated.
- Gable requires continuous bottom chord bearing.
- Truss to be fully sheathed from one face or securely braced against lateral movement (i.e. diagonal web).
- Gable studs spaced at 1-4-0 oc.
- This truss is designed in accordance with the 2018 International Residential Code sections R502.11.1 and R802.10.2 and referenced standard ANSI/TPI 1.
- Recommend 2x6 strongbacks, on edge, spaced at 10-0-0 oc and fastened to each truss with 3-10d (0.131" X 3") nails. Strongbacks to be attached to walls at their outer ends or restrained by other means.

**LOAD CASE(S)** Standard

Job Ashby	Truss F2	Truss Type Floor	Qty 3	Ply 1	Job Reference (optional)
--------------	-------------	---------------------	----------	----------	--------------------------

Carter Components, Sanford, NC, user

Run: 8.53 S Mar 28 2022 Print: 8.530 S Mar 28 2022 MiTek Industries, Inc. Wed May 11 15:47:43

Page: 1

ID:KlbRyxbB5gb\_DSfStkStfDzHcyN-tjhl2rGcyLkQANi?jlfYrYaSu38mUbuMJdrA5PAzHY0U

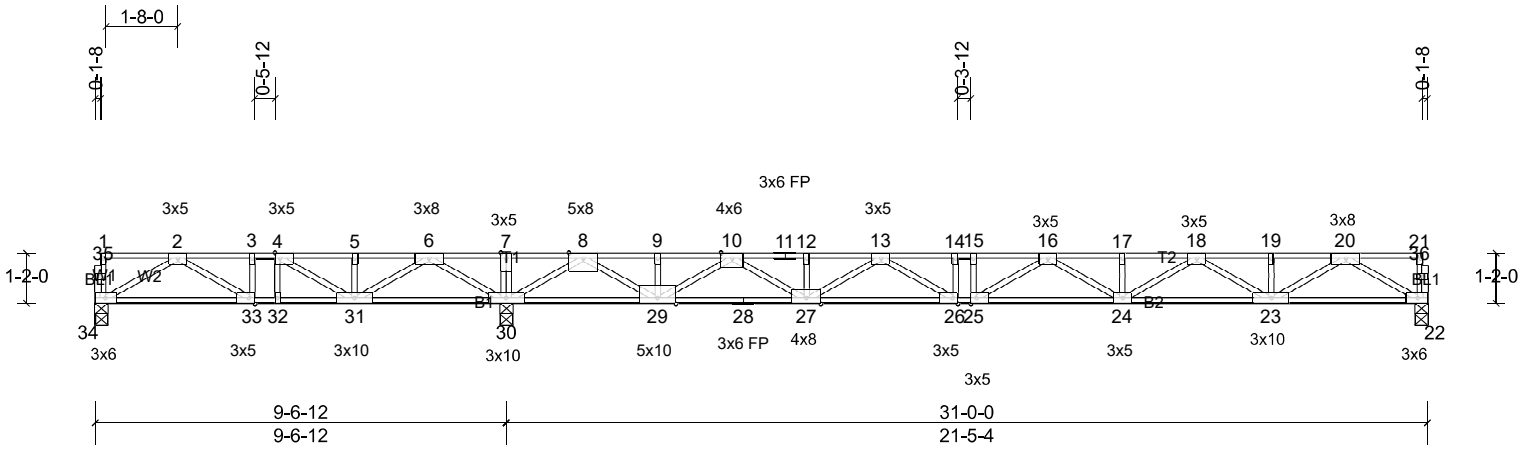

Scale = 1:53.6

Plate Offsets (X, Y): [4:0-1-8,Edge], [25:0-1-8,Edge], [26:0-1-8,Edge], [33:0-1-8,Edge]

Loading	(psf)	Spacing	2-0-0	CSI	DEFL	in	(loc)	l/defl	L/d	PLATES	GRIP	
TCLL	40.0	Plate Grip DOL	1.00	TC	0.91	Vert(LL)	-0.42	24-25	>602	360	MT20	244/190
TCDL	10.0	Lumber DOL	1.00	BC	0.86	Vert(CT)	-0.58	24-25	>440	240		
BCLL	0.0	Rep Stress Incr	YES	WB	1.00	Horz(CT)	0.04	22	n/a	n/a		
BCDL	5.0	Code	IRC2018/TPI2014	Matrix-MSH								
											Weight: 160 lb	FT = 20%F, 11%E

**LUMBER**

TOP CHORD 2x4 SP No.1(flat) \*Except\* T2:2x4 SP No.2(flat)  
 BOT CHORD 2x4 SP No.2(flat) \*Except\* B2:2x4 SP No.1(flat)  
 WEBS 2x4 SP No.3(flat)  
 OTHERS 2x4 SP No.3(flat)

**BRACING**

TOP CHORD Structural wood sheathing directly applied or 2-2-0 oc purlins, except end verticals.  
 BOT CHORD Rigid ceiling directly applied or 6-0-0 oc bracing.

**REACTIONS** (lb/size) 22=961/0-3-8, (min. 0-1-8), 30=2360/0-3-8, (min. 0-1-8), 34=49/0-3-8, (min. 0-1-8)  
 Max Uplift 34=-294 (LC 4)  
 Max Grav 22=974 (LC 4), 30=2360 (LC 1), 34=358 (LC 3)

**FORCES** (lb) - Max. Comp./Max. Ten. - All forces 250 (lb) or less except when shown.  
 TOP CHORD 2-3=-578/1259, 3-4=-578/1259, 4-5=-243/2173, 5-6=-243/2173, 6-7=0/4117, 7-8=0/4117, 8-9=-111/546, 9-10=-111/546, 10-11=-2653/0, 11-12=-2653/0, 12-13=-2653/0, 13-14=-4029/0, 14-15=-4029/0, 15-16=-4029/0, 16-17=-4006/0, 17-18=-4006/0, 18-19=-2675/0, 19-20=-2675/0  
 BOT CHORD 33-34=-547/477, 32-33=-1259/578, 31-32=-1259/578, 30-31=-2977/0, 29-30=-1970/0, 28-29=0/1497, 27-28=0/1497, 26-27=0/3474, 25-26=0/4029, 24-25=0/4190, 23-24=0/3490, 22-23=0/1529  
 WEBS 6-30=-1699/0, 2-34=-547/633, 6-31=0/1316, 2-33=-830/118, 3-33=-43/302, 4-31=-1248/0, 8-30=-2484/0, 20-22=-1764/0, 8-29=0/2106, 20-23=0/1338, 10-29=-1708/0, 18-23=-952/0, 10-27=0/1375, 18-24=0/602, 13-27=-983/0, 16-24=-292/63, 13-26=0/841, 16-25=-502/237, 14-26=-259/0

**NOTES**

- 1) Unbalanced floor live loads have been considered for this design.
- 2) All plates are 1.5x3 MT20 unless otherwise indicated.
- 3) One H2.5A Simpson Strong-Tie connectors recommended to connect truss to bearing walls due to UPLIFT at jt(s) 34. This connection is for uplift only and does not consider lateral forces.
- 4) This truss is designed in accordance with the 2018 International Residential Code sections R502.11.1 and R802.10.2 and referenced standard ANSI/TPI 1.
- 5) Required 2x6 strongbacks, on edge, spaced at 10-00-00 oc and fastened to each truss with 3-10d (0.131" X 3") nails. Strongbacks to be attached to walls at their outer ends or restrained by other means.
- 6) CAUTION, Do not erect truss backwards.

**LOAD CASE(S)** Standard

Job Ashby	Truss F2GE	Truss Type Floor Supported Gable	Qty 1	Ply 1	Job Reference (optional)
--------------	---------------	-------------------------------------	----------	----------	--------------------------

Carter Components, Sanford, NC, user

Run: 8.53 S Mar 28 2022 Print: 8.530 S Mar 28 2022 MiTek Industries, Inc. Wed May 11 15:47:43

Page: 1

ID:GgjBMddRcHriTmpr?iULkezHcyL-tjhl2rGcyLkQANI?jlfYaS568zkb7YJdrA5PAzHY0U

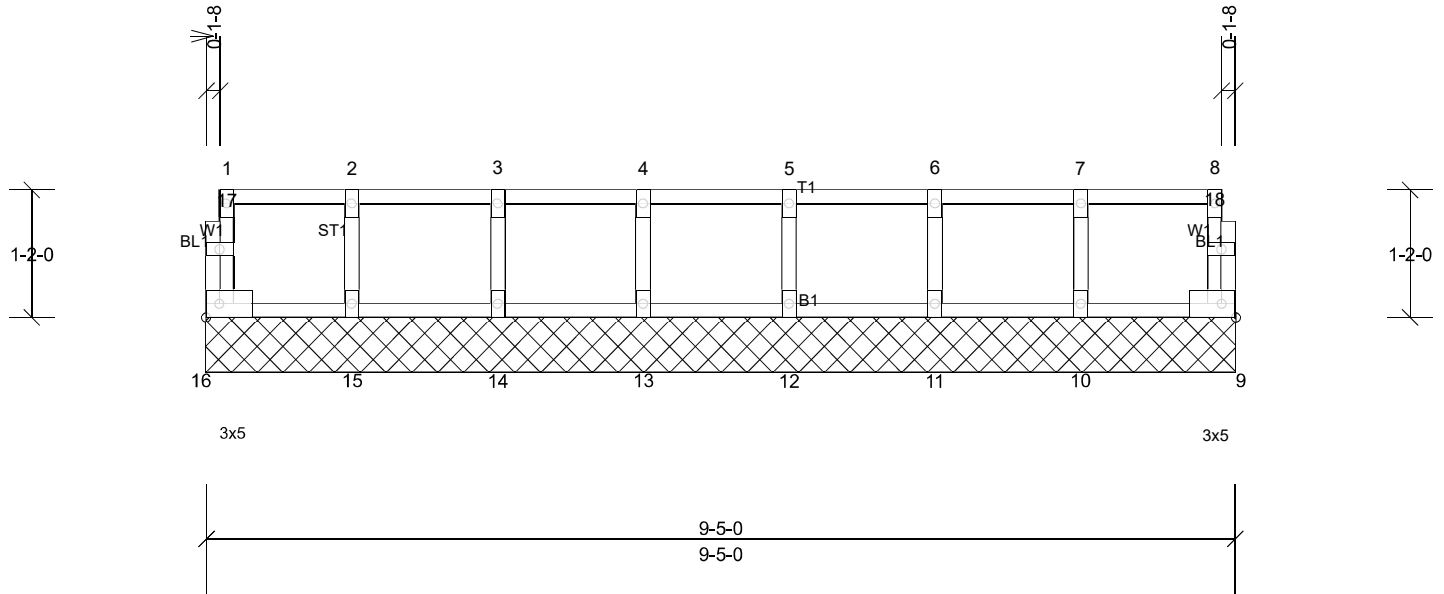

Scale = 1:21.1

Loading	(psf)	Spacing	2-0-0	CSI		DEFL	in	(loc)	l/defl	L/d	PLATES	GRIP
TCLL	40.0	Plate Grip DOL	1.00	TC	0.08	Vert(LL)	n/a	-	n/a	999	MT20	244/190
TCDL	10.0	Lumber DOL	1.00	BC	0.01	Vert(TL)	n/a	-	n/a	999		
BCLL	0.0	Rep Stress Incr	YES	WB	0.03	Horiz(TL)	0.00	9	n/a	n/a		
BCDL	5.0	Code	IRC2018/TPI2014	Matrix-MR							Weight: 41 lb	FT = 20%F, 11%E

**LUMBER**

TOP CHORD 2x4 SP No.2(flat)  
 BOT CHORD 2x4 SP No.2(flat)  
 WEBS 2x4 SP No.3(flat)  
 OTHERS 2x4 SP No.3(flat)

**BRACING**

TOP CHORD Structural wood sheathing directly applied or 6-0-0 oc purlins, except end verticals.  
 BOT CHORD Rigid ceiling directly applied or 10-0-0 oc bracing.

**REACTIONS** All bearings 9-5-0.

(lb) - Max Grav All reactions 250 (lb) or less at joint(s) 9, 10, 11, 12, 13, 14, 15, 16

**FORCES** (lb) - Max. Comp./Max. Ten. - All forces 250 (lb) or less except when shown.

**NOTES**

- All plates are 1.5x3 MT20 unless otherwise indicated.
- Gable requires continuous bottom chord bearing.
- Truss to be fully sheathed from one face or securely braced against lateral movement (i.e. diagonal web).
- Gable studs spaced at 1-4-0 oc.
- This truss is designed in accordance with the 2018 International Residential Code sections R502.11.1 and R802.10.2 and referenced standard ANSI/TPI 1.
- Recommend 2x6 strongbacks, on edge, spaced at 10-00-00 oc and fastened to each truss with 3-10d (0.131" X 3") nails. Strongbacks to be attached to walls at their outer ends or restrained by other means.

**LOAD CASE(S)** Standard

Job Ashby	Truss F3	Truss Type Floor	Qty 2	Ply 1	Job Reference (optional)
--------------	-------------	---------------------	----------	----------	--------------------------

Carter Components, Sanford, NC, user

Run: 8.53 S Mar 28 2022 Print: 8.530 S Mar 28 2022 MiTek Industries, Inc. Wed May 11 15:47:43

Page: 1

ID: oU9p9Hcpr\_jrrcEeR1z6CQzHcyM-tjhl2rGcylKQANI?jfrYaSuw8kmbvbJdrA5PAzHY0U

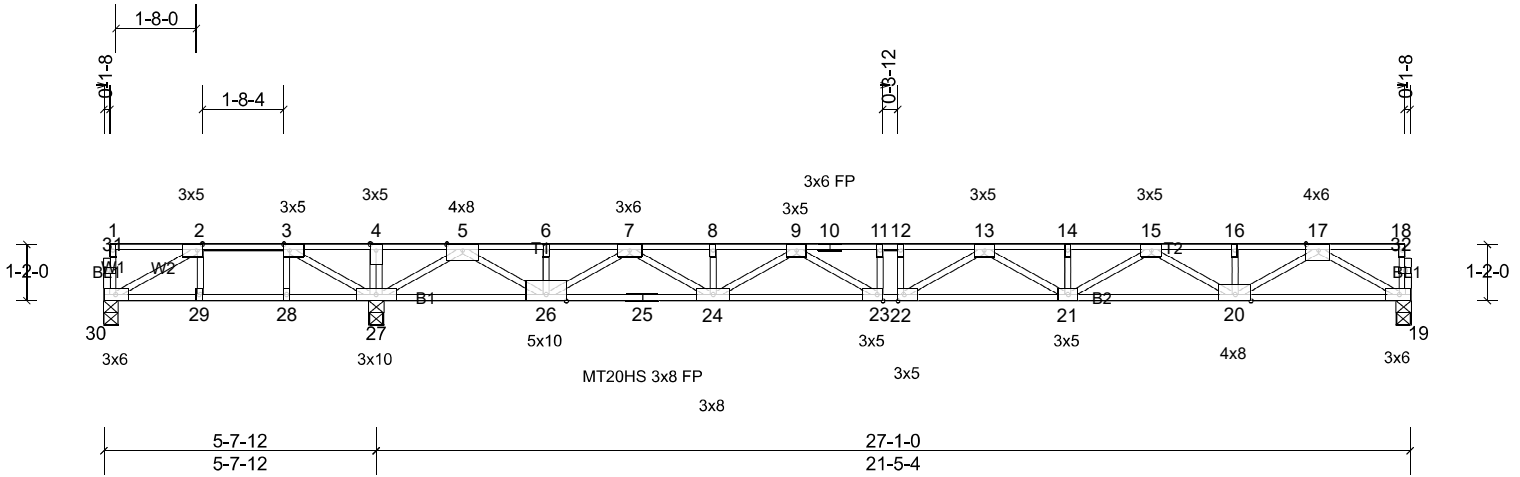

Scale = 1:47.8

Plate Offsets (X, Y): [2:0-1-8,Edge], [3:0-1-8,Edge], [22:0-1-8,Edge], [23:0-1-8,Edge]

Loading	(psf)	Spacing	2-0-0	CSI	DEFL	in	(loc)	l/defl	L/d	PLATES	GRIP	
TCLL	40.0	Plate Grip DOL	1.00	TC	0.92	Vert(LL)	-0.50	21-22	>515	360	MT20HS	187/143
TCDL	10.0	Lumber DOL	1.00	BC	0.97	Vert(CT)	-0.68	21-22	>374	240	MT20	244/190
BCLL	0.0	Rep Stress Incr	YES	WB	0.92	Horz(CT)	0.08	19	n/a	n/a		
BCDL	5.0	Code	IRC2018/TPI2014	Matrix-MSH								
											Weight: 138 lb	FT = 20%F, 11%E

**LUMBER**

TOP CHORD 2x4 SP 2400F 2.0E(flat) \*Except\* T2:2x4 SP No.2(flat)  
 BOT CHORD 2x4 SP No.1(flat)  
 WEBS 2x4 SP No.3(flat)  
 OTHERS 2x4 SP No.3(flat)

**BRACING**

TOP CHORD Structural wood sheathing directly applied or 2-2-0 oc purlins, except end verticals.  
 BOT CHORD Rigid ceiling directly applied or 2-2-0 oc bracing.

**REACTIONS** (lb/size) 19=1054/0-3-8, (min. 0-1-8), 27=2019/0-3-8, (min. 0-1-8),  
 30=-134/0-3-8, (min. 0-1-8)  
 Max Uplift 30=-345 (LC 4)  
 Max Grav 19=1059 (LC 7), 27=2019 (LC 1), 30=176 (LC 3)

**FORCES** (lb) - Max. Comp./Max. Ten. - All forces 250 (lb) or less except when shown.  
 TOP CHORD 2-3=-67/1016, 3-4=0/2387, 4-5=0/2387, 5-6=-1510/0, 6-7=-1510/0, 7-8=-3823/0, 8-9=-3823/0, 9-10=-4899/0,  
 10-11=-4899/0, 11-12=-4899/0, 12-13=-4899/0, 13-14=-4573/0, 14-15=-4573/0, 15-16=-2962/0, 16-17=-2962/0  
 BOT CHORD 29-30=-1016/67, 28-29=-1016/67, 27-28=-1016/67, 26-27=-393/60, 25-26=0/2810, 24-25=0/2810, 23-24=0/4496,  
 22-23=0/4899, 21-22=0/4899, 20-21=0/3917, 19-20=0/1675  
 WEBS 3-27=-1784/0, 2-30=-69/1175, 2-29=-272/0, 3-28=0/321, 5-27=-2417/0, 17-19=-1933/0, 5-26=0/1939, 17-20=0/1502,  
 7-26=-1534/0, 15-20=-1115/0, 7-24=0/1201, 15-21=0/766, 9-24=-804/0, 13-21=-430/0, 9-23=-49/715, 13-22=-367/391

**NOTES**

- 1) Unbalanced floor live loads have been considered for this design.
- 2) All plates are MT20 plates unless otherwise indicated.
- 3) All plates are 1.5x3 MT20 unless otherwise indicated.
- 4) One H2.5A Simpson Strong-Tie connectors recommended to connect truss to bearing walls due to UPLIFT at jt(s) 30. This connection is for uplift only and does not consider lateral forces.
- 5) This truss is designed in accordance with the 2018 International Residential Code sections R502.11.1 and R802.10.2 and referenced standard ANSI/TPI 1.
- 6) Required 2x6 strongbacks, on edge, spaced at 10-00-00 oc and fastened to each truss with 3-10d (0.131" X 3") nails. Strongbacks to be attached to walls at their outer ends or restrained by other means.
- 7) CAUTION, Do not erect truss backwards.

**LOAD CASE(S)** Standard

Job Ashby	Truss F3A	Truss Type Floor	Qty 4	Ply 1	Job Reference (optional)
--------------	--------------	---------------------	----------	----------	--------------------------

Carter Components, Sanford, NC, user

Run: 8.53 S Mar 28 2022 Print: 8.530 S Mar 28 2022 MiTek Industries, Inc. Wed May 11 15:47:44

Page: 1

ID: oU9p9Hopr\_jrrcEeR1z6CQzHcyM-LvFgGAHEjfsHoXHBGTA44n?3DY5LKMdTsVvexczHYOT

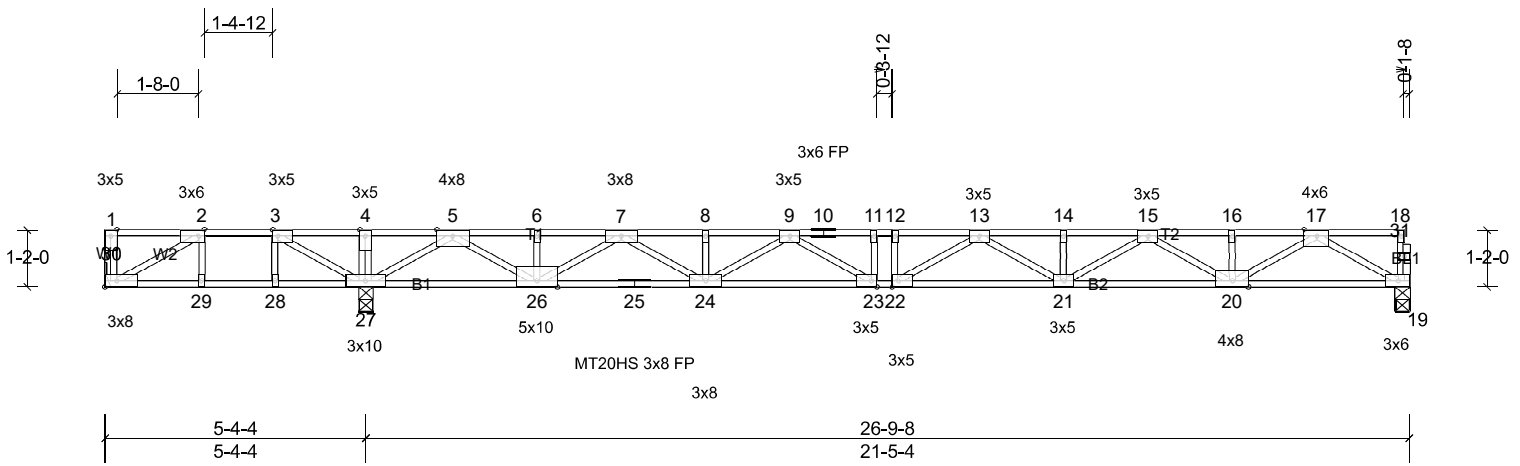

Scale = 1:47.3

Plate Offsets (X, Y): [2:0-1-8,Edge], [3:0-1-8,Edge], [22:0-1-8,Edge], [23:0-1-8,Edge]

Loading	(psf)	Spacing	2-0-0	CSI	DEFL	in	(loc)	l/defl	L/d	PLATES	GRIP
TCLL	40.0	Plate Grip DOL	1.00	TC	0.95	Vert(LL)	-0.48	21-22	>534	360	MT20HS 187/143
TCDL	10.0	Lumber DOL	1.00	BC	0.95	Vert(CT)	-0.66	21-22	>388	240	MT20 244/190
BCLL	0.0	Rep Stress Incr	YES	WB	0.94	Horz(CT)	0.08	19	n/a	n/a	
BCDL	5.0	Code	IRC2018/TPI2014	Matrix-MSH							
											Weight: 138 lb FT = 20%F, 11%E

**LUMBER**

TOP CHORD 2x4 SP 2400F 2.0E(flat) \*Except\* T2:2x4 SP No.2(flat)  
 BOT CHORD 2x4 SP No.1(flat)  
 WEBS 2x4 SP No.3(flat)  
 OTHERS 2x4 SP No.3(flat)

**BRACING**

TOP CHORD Structural wood sheathing directly applied or 2-2-0 oc purlins, except end verticals.  
 BOT CHORD Rigid ceiling directly applied or 2-2-0 oc bracing.

**REACTIONS** (lb/size) 19=1038/0-3-8, (min. 0-1-8), 27=2108/0-3-8, (min. 0-1-8), 30=-233/ Mechanical, (min. 0-1-8)  
 Max Uplift 30=-438 (LC 4)  
 Max Grav 19=1043 (LC 7), 27=2108 (LC 1), 30=142 (LC 3)

**FORCES** (lb) - Max. Comp./Max. Ten. - All forces 250 (lb) or less except when shown.  
 TOP CHORD 2-3=0/1187, 3-4=0/2705, 4-5=0/2705, 5-6=-1232/0, 6-7=-1232/0, 7-8=-3598/0, 8-9=-3598/0, 9-10=-4733/0, 10-11=-4733/0, 11-12=-4733/0, 12-13=-4733/0, 13-14=-4464/0, 14-15=-4464/0, 15-16=-2907/0, 16-17=-2907/0  
 BOT CHORD 29-30=-1187/0, 28-29=-1187/0, 27-28=-1187/0, 26-27=-599/0, 25-26=0/2559, 24-25=0/2559, 23-24=0/4300, 22-23=0/4733, 21-22=0/4763, 20-21=0/3835, 19-20=0/1647  
 WEBS 3-27=-1935/0, 2-30=0/1362, 2-29=-319/0, 3-28=0/365, 5-27=-2449/0, 17-19=-1900/0, 5-26=0/1969, 17-20=0/1471, 7-26=-1565/0, 15-20=-1084/0, 7-24=0/1231, 15-21=0/734, 9-24=-835/0, 13-21=-409/0, 9-23=-25/736, 13-22=-387/368

**NOTES**

- 1) Unbalanced floor live loads have been considered for this design.
- 2) All plates are MT20 plates unless otherwise indicated.
- 3) All plates are 1.5x3 MT20 unless otherwise indicated.
- 4) Refer to girder(s) for truss to truss connections.
- 5) Provide mechanical connection (by others) of truss to bearing plate capable of withstanding 438 lb uplift at joint 30.
- 6) This truss is designed in accordance with the 2018 International Residential Code sections R502.11.1 and R802.10.2 and referenced standard ANSI/TPI 1.
- 7) Required 2x6 strongbacks, on edge, spaced at 10-00-00 oc and fastened to each truss with 3-10d (0.131" X 3") nails. Strongbacks to be attached to walls at their outer ends or restrained by other means.
- 8) CAUTION, Do not erect truss backwards.

**LOAD CASE(S)** Standard

Job Ashby	Truss F4	Truss Type Floor	Qty 1	Ply 1	Job Reference (optional)
--------------	-------------	---------------------	----------	----------	--------------------------

Carter Components, Sanford, NC, user

Run: 8.53 S Mar 28 2022 Print: 8.530 S Mar 28 2022 MiTek Industries, Inc. Wed May 11 15:47:44

Page: 1

ID:GgJBMddRcHriTmpr?IULkezHcyL-LvFgGAHEjfsHoXHBGTA44n?DSYF9KXtTsVvexcZHYOT

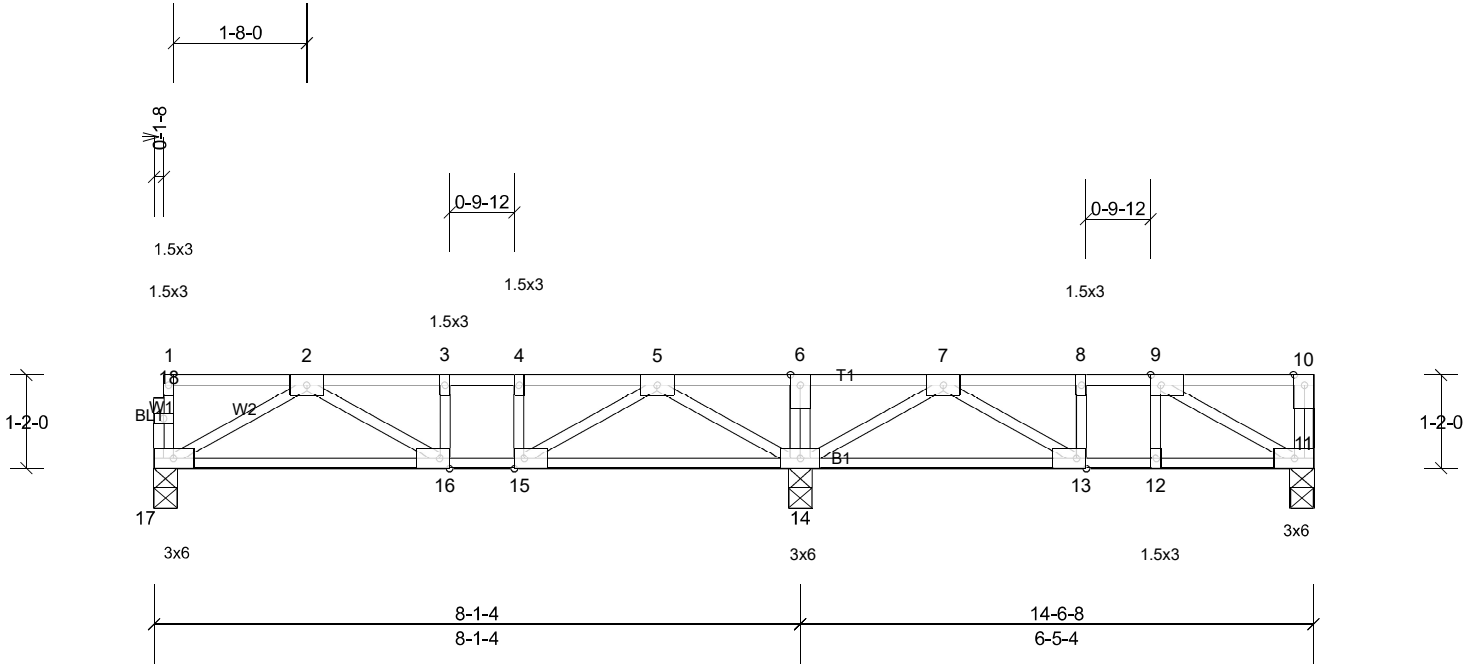

Scale = 1:28.9

Plate Offsets (X, Y): [9:0-1-8,Edge], [13:0-1-8,Edge], [15:0-1-8,Edge], [16:0-1-8,Edge]

Loading	(psf)	Spacing	2-0-0	CSI		DEFL	in	(loc)	l/defl	L/d	PLATES	GRIP
TCLL	40.0	Plate Grip DOL	1.00	TC	0.29	Vert(LL)	-0.03	16-17	>999	360	MT20	244/190
TCDL	10.0	Lumber DOL	1.00	BC	0.26	Vert(CT)	-0.05	16-17	>999	240		
BCLL	0.0	Rep Stress Incr	YES	WB	0.22	Horz(CT)	0.01	11	n/a	n/a		
BCDL	5.0	Code	IRC2018/TPI2014	Matrix-MSH							Weight: 76 lb	FT = 20%F, 11%E

**LUMBER**  
TOP CHORD 2x4 SP No.2(flat)  
BOT CHORD 2x4 SP No.2(flat)  
WEBS 2x4 SP No.3(flat)  
OTHERS 2x4 SP No.3(flat)

**BRACING**  
TOP CHORD Structural wood sheathing directly applied or 6-0-0 oc purlins, except end verticals.  
BOT CHORD Rigid ceiling directly applied or 6-0-0 oc bracing.

**REACTIONS** (lb/size) 11=267/0-3-8, (min. 0-1-8), 14=929/0-3-8, (min. 0-1-8), 17=369/0-3-8, (min. 0-1-8)  
Max Grav 11=298 (LC 4), 14=929 (LC 1), 17=393 (LC 10)

**FORCES** (lb) - Max. Comp./Max. Ten. - All forces 250 (lb) or less except when shown.  
TOP CHORD 2-3=-696/0, 3-4=-696/0, 4-5=-696/0, 5-6=0/487, 6-7=0/487, 7-8=-390/0, 8-9=-390/0  
BOT CHORD 16-17=0/536, 15-16=0/696, 14-15=-75/369, 12-13=0/390, 11-12=0/390  
WEBS 5-14=-783/0, 2-17=-616/0, 5-15=0/456, 7-14=-629/0, 9-11=-447/0, 7-13=0/266

- NOTES**
- Unbalanced floor live loads have been considered for this design.
  - All plates are 3x5 MT20 unless otherwise indicated.
  - This truss is designed in accordance with the 2018 International Residential Code sections R502.11.1 and R802.10.2 and referenced standard ANSI/TPI 1.
  - Recommend 2x6 strongbacks, on edge, spaced at 10-00-00 oc and fastened to each truss with 3-10d (0.131" X 3") nails. Strongbacks to be attached to walls at their outer ends or restrained by other means.
  - CAUTION, Do not erect truss backwards.

**LOAD CASE(S)** Standard

Job Ashby	Truss F5GR	Truss Type Floor Girder	Qty 1	Ply 1	Job Reference (optional)
--------------	---------------	----------------------------	----------	----------	--------------------------

Carter Components, Sanford, NC, user

Run: 8.53 S Mar 28 2022 Print: 8.530 S Mar 28 2022 MiTek Industries, Inc. Wed May 11 15:47:44

Page: 1

ID:Z1erq0iqzRkioqrbVj6?X6zHcyE-LvFgGAHEjfsHoXHBGTA44n?5PYEjKS3TsVvexczHYOT

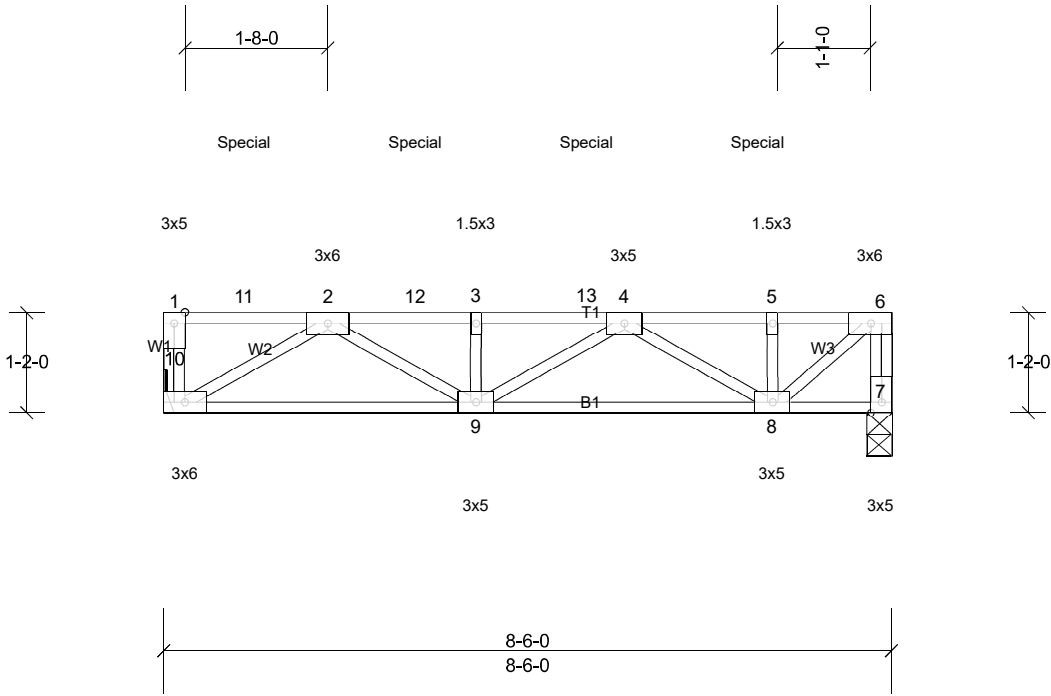

Scale = 1:26.9

Loading	(psf)	Spacing	2-0-0	CSI		DEFL	in	(loc)	l/defl	L/d	PLATES	GRIP
TCLL	40.0	Plate Grip DOL	1.00	TC	0.81	Vert(LL)	0.04	8-9	>999	360	MT20	244/190
TCDL	10.0	Lumber DOL	1.00	BC	0.35	Vert(CT)	0.04	8-9	>999	240		
BCLL	0.0	Rep Stress Incr	NO	WB	0.53	Horz(CT)	-0.01	7	n/a	n/a		
BCDL	5.0	Code	IRC2018/TPI2014	Matrix-MP							Weight: 47 lb	FT = 20%F, 11%E

**LUMBER**

TOP CHORD 2x4 SP No.1(flat)  
 BOT CHORD 2x4 SP No.2(flat)  
 WEBS 2x4 SP No.3(flat)

**BRACING**

TOP CHORD Structural wood sheathing directly applied or 6-0-0 oc purlins, except end verticals.  
 BOT CHORD Rigid ceiling directly applied or 6-0-0 oc bracing.

**REACTIONS** (lb/size) 7=533/0-3-8, (min. 0-1-8), 10=552/ Mechanical, (min. 0-1-8)  
 Max Uplift 7=-550 (LC 3), 10=-684 (LC 3)

**FORCES** (lb) - Max. Comp./Max. Ten. - All forces 250 (lb) or less except when shown.  
 TOP CHORD 6-7=-530/550, 2-12=-1081/1274, 3-12=-1081/1274, 3-13=-1081/1274, 4-13=-1081/1274, 4-5=-587/708, 5-6=-587/708  
 BOT CHORD 9-10=-954/761, 8-9=-1194/1008  
 WEBS 2-10=-881/1104, 2-9=-374/374, 3-9=-198/284, 4-8=-492/568, 5-8=-202/315, 6-8=-915/760

**NOTES**

- Unbalanced floor live loads have been considered for this design.
- Refer to girder(s) for truss to truss connections.
- Provide mechanical connection (by others) of truss to bearing plate capable of withstanding 684 lb uplift at joint 10.
- One RT8A MiTek connectors recommended to connect truss to bearing walls due to UPLIFT at jt(s) 7. This connection is for uplift only and does not consider lateral forces.
- This truss is designed in accordance with the 2018 International Residential Code sections R502.11.1 and R802.10.2 and referenced standard ANSI/TPI 1.
- Recommend 2x6 strongbacks, on edge, spaced at 10-00-00 oc and fastened to each truss with 3-10d (0.131" X 3") nails. Strongbacks to be attached to walls at their outer ends or restrained by other means.
- Hanger(s) or other connection device(s) shall be provided sufficient to support concentrated load(s) 51 lb down and 528 lb up at 0-11-4, 42 lb down and 538 lb up at 2-11-4, and 42 lb down and 538 lb up at 4-11-4, and 42 lb down and 538 lb up at 6-11-4 on top chord. The design/selection of such connection device(s) is the responsibility of others.
- In the LOAD CASE(S) section, loads applied to the face of the truss are noted as front (F) or back (B).

**LOAD CASE(S)** Standard

- Dead + Floor Live (balanced): Lumber Increase=1.00, Plate Increase=1.00  
 Uniform Loads (lb/ft)  
 Vert: 7-10=-10, 1-6=-100  
 Concentrated Loads (lb)  
 Vert: 5=-42 (F), 11=-51 (F), 12=-42 (F), 13=-42 (F)



Job Ashby	Truss F7GR	Truss Type Floor Girder	Qty 1	Ply 1	Job Reference (optional)
--------------	---------------	----------------------------	----------	----------	--------------------------

Carter Components, Sanford, NC, user

Run: 8.53 S Mar 28 2022 Print: 8.530 S Mar 28 2022 MiTek Industries, Inc. Wed May 11 15:47:44

Page: 1

ID:Z1erq0iqzRkioqrBvj6?X6zHcyE-LvFgGAHEJfsHoXHBGTA44n?DdY9aKUeTsVvexczHYOT

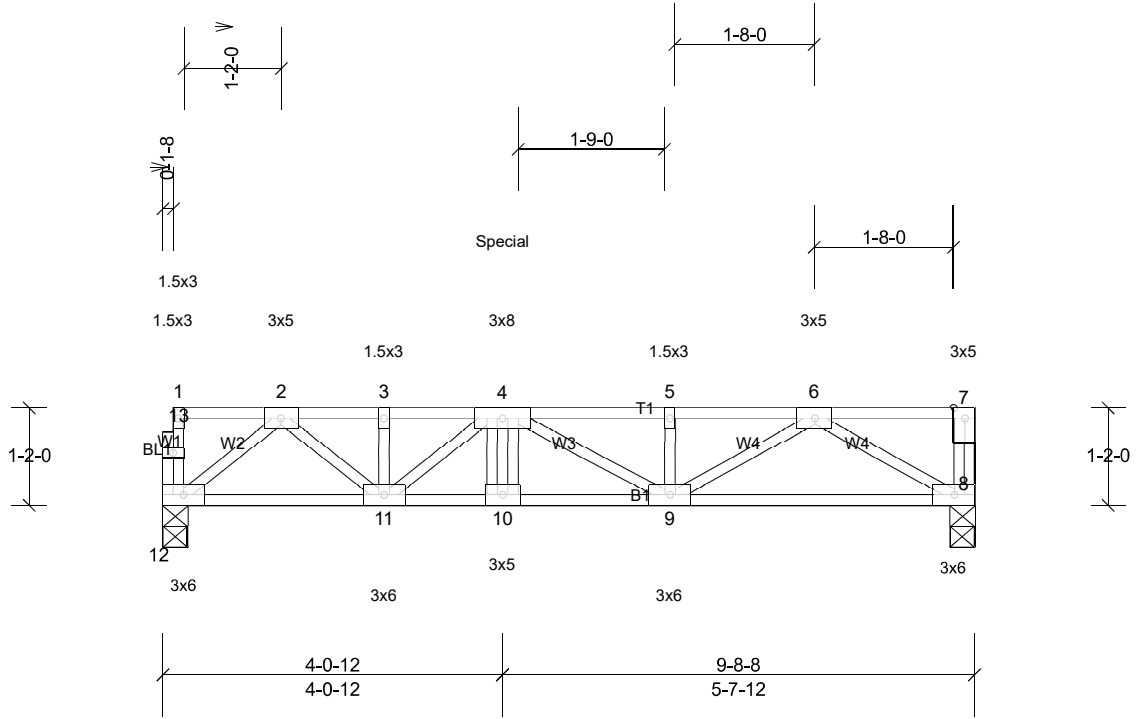

Scale = 1:27.6

Loading	(psf)	Spacing	2-0-0	CSI	0.28	DEFL	in	(loc)	l/defl	L/d	PLATES	GRIP
TCLL	40.0	Plate Grip DOL	1.00	TC	0.28	Vert(LL)	-0.07	9-10	>999	360	MT20	244/190
TCDL	10.0	Lumber DOL	1.00	BC	0.68	Vert(CT)	-0.07	9-10	>999	240		
BCLL	0.0	Rep Stress Incr	NO	WB	0.42	Horz(CT)	0.02	8	n/a	n/a		
BCDL	5.0	Code	IRC2018/TPI2014	Matrix-MSH							Weight: 56 lb	FT = 20%F, 11%E

**LUMBER**

TOP CHORD 2x4 SP No.2(flat)  
 BOT CHORD 2x4 SP No.2(flat)  
 WEBS 2x4 SP No.3(flat)  
 OTHERS 2x4 SP No.3(flat)

**BRACING**

TOP CHORD Structural wood sheathing directly applied or 6-0-0 oc purlins, except end verticals.  
 BOT CHORD Rigid ceiling directly applied or 6-0-0 oc bracing. Except: 10-0-0 oc bracing: 8-9.

**REACTIONS** (lb/size) 8=708/0-3-8, (min. 0-1-8), 12=778/0-3-8, (min. 0-1-8)

**FORCES** (lb) - Max. Comp./Max. Ten. - All forces 250 (lb) or less except when shown.

TOP CHORD 2-3=-1570/172, 3-4=-1570/172, 4-5=-1769/0, 5-6=-1769/0  
 BOT CHORD 11-12=0/889, 10-11=-543/2154, 9-10=-543/2154, 8-9=0/1064  
 WEBS 6-8=-1230/0, 6-9=-174/824, 4-9=-434/650, 2-12=-1138/4, 2-11=-225/892, 4-11=-725/460

**NOTES**

- Unbalanced floor live loads have been considered for this design.
- This truss is designed in accordance with the 2018 International Residential Code sections R502.11.1 and R802.10.2 and referenced standard ANSI/TPI 1.
- Recommend 2x6 strongbacks, on edge, spaced at 10-00-00 oc and fastened to each truss with 3-10d (0.131" X 3") nails. Strongbacks to be attached to walls at their outer ends or restrained by other means.
- CAUTION, Do not erect truss backwards.
- Hanger(s) or other connection device(s) shall be provided sufficient to support concentrated load(s) 452 lb down and 784 lb up at 4-0-12 on top chord. The design/selection of such connection device(s) is the responsibility of others.
- In the LOAD CASE(S) section, loads applied to the face of the truss are noted as front (F) or back (B).

**LOAD CASE(S)** Standard

- Dead + Floor Live (balanced): Lumber Increase=1.00, Plate Increase=1.00  
 Uniform Loads (lb/ft)  
 Vert: 8-12=-10, 1-7=-100  
 Concentrated Loads (lb)  
 Vert: 4=-452 (B)

Job Ashby	Truss F8	Truss Type Floor	Qty 4	Ply 1	Job Reference (optional)
--------------	-------------	---------------------	----------	----------	--------------------------

Carter Components, Sanford, NC, user

Run: 8.53 S Mar 28 2022 Print: 8.530 S Mar 28 2022 MiTek Industries, Inc. Wed May 11 15:47:44

Page: 1

ID:s613kbbZKMT7cl4GJcxe7?zHcyO-LvFgGAHEjfsHoXHBGTA44n?86Y5vKRqTsVvexczHYOT

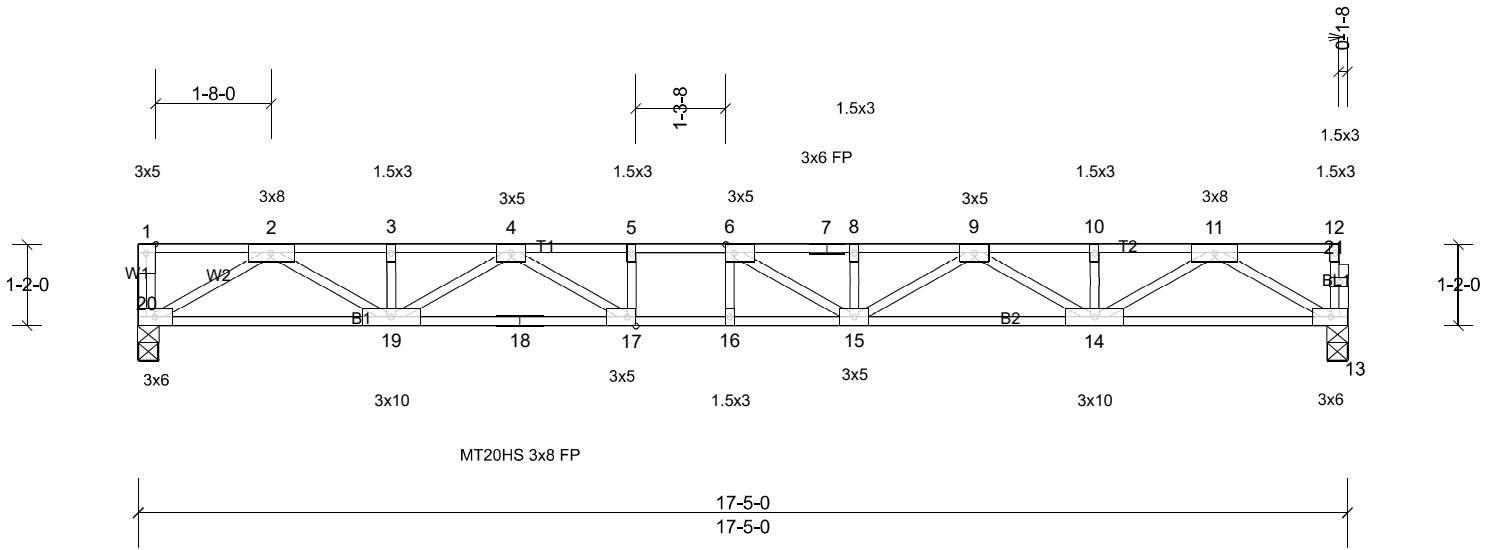

Scale = 1:33.2

Plate Offsets (X, Y): [6:0-1-8,Edge], [17:0-1-8,Edge]

Loading	(psf)	Spacing	2-0-0	CSI	DEFL	in	(loc)	l/defl	L/d	PLATES	GRIP	
TCLL	40.0	Plate Grip DOL	1.00	TC	0.64	Vert(LL)	-0.31	15-16	>670	360	MT20HS	187/143
TCDL	10.0	Lumber DOL	1.00	BC	0.91	Vert(CT)	-0.42	15-16	>489	240	MT20	244/190
BCLL	0.0	Rep Stress Incr	YES	WB	0.60	Horz(CT)	0.07	13	n/a	n/a		
BCDL	5.0	Code	IRC2018/TPI2014	Matrix-MSH								
											Weight: 89 lb	FT = 20%F, 11%E

**LUMBER**

TOP CHORD 2x4 SP No.2(flat)  
 BOT CHORD 2x4 SP No.2(flat) \*Except\* B2:2x4 SP No.1(flat)  
 WEBS 2x4 SP No.3(flat)  
 OTHERS 2x4 SP No.3(flat)

**BRACING**

TOP CHORD Structural wood sheathing directly applied or 5-7-10 oc purlins, except end verticals.  
 BOT CHORD Rigid ceiling directly applied or 10-0-0 oc bracing.

**REACTIONS** (lb/size) 13=938/0-3-8, (min. 0-1-8), 20=944/0-3-8, (min. 0-1-8)

**FORCES** (lb) - Max. Comp./Max. Ten. - All forces 250 (lb) or less except when shown.

TOP CHORD 2-3=-2553/0, 3-4=-2553/0, 4-5=-3820/0, 5-6=-3820/0, 6-7=-3780/0, 7-8=-3780/0, 8-9=-3780/0, 9-10=-2555/0, 10-11=-2555/0

BOT CHORD 19-20=0/1466, 18-19=0/3308, 17-18=0/3308, 16-17=0/3820, 15-16=0/3820, 14-15=0/3307, 13-14=0/1467

WEBS 11-13=-1692/0, 2-20=-1696/0, 11-14=0/1270, 2-19=0/1269, 9-14=-877/0, 4-19=-882/0, 9-15=0/552, 4-17=0/785, 5-17=-255/0, 6-15=-462/300

**NOTES**

- Unbalanced floor live loads have been considered for this design.
- All plates are MT20 plates unless otherwise indicated.
- This truss is designed in accordance with the 2018 International Residential Code sections R502.11.1 and R802.10.2 and referenced standard ANSI/TPI 1.
- Recommend 2x6 strongbacks, on edge, spaced at 10-00-00 oc and fastened to each truss with 3-10d (0.131" X 3") nails. Strongbacks to be attached to walls at their outer ends or restrained by other means.
- CAUTION, Do not erect truss backwards.

**LOAD CASE(S)** Standard

Job Ashby	Truss F8A	Truss Type Floor	Qty 5	Ply 1	Job Reference (optional)
--------------	--------------	---------------------	----------	----------	--------------------------

Carter Components, Sanford, NC, user

Run: 8.53 S Mar 28 2022 Print: 8.530 S Mar 28 2022 MiTek Industries, Inc. Wed May 11 15:47:45

Page: 1

ID:NvTgXGaxZ3LG\_8W3mvQPaozHcyP-p5p2TWIsUy\_8QgsOqAhJd?YKAYsu3uHc59fCT2zHY0S

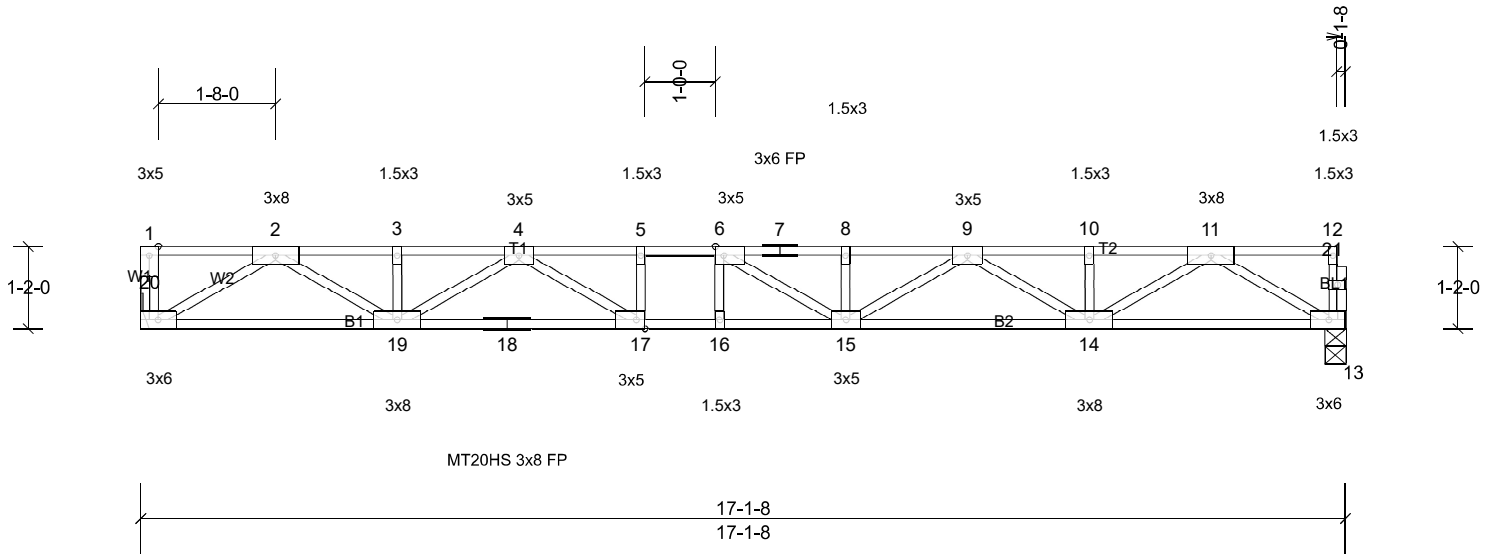

Scale = 1:32.8

Plate Offsets (X, Y): [6:0-1-8,Edge], [17:0-1-8,Edge]

Loading	(psf)	Spacing	2-0-0	CSI	DEFL	in	(loc)	l/defl	L/d	PLATES	GRIP	
TCLL	40.0	Plate Grip DOL	1.00	TC	0.55	Vert(LL)	-0.28	15-16	>720	360	MT20HS	187/143
TCDL	10.0	Lumber DOL	1.00	BC	0.87	Vert(CT)	-0.39	15-16	>525	240	MT20	244/190
BCLL	0.0	Rep Stress Incr	YES	WB	0.59	Horz(CT)	0.06	13	n/a	n/a		
BCDL	5.0	Code	IRC2018/TPI2014	Matrix-MSH								
											Weight: 88 lb	FT = 20%F, 11%E

**LUMBER**

TOP CHORD 2x4 SP No.2(flat)  
 BOT CHORD 2x4 SP No.2(flat) \*Except\* B2:2x4 SP No.1(flat)  
 WEBS 2x4 SP No.3(flat)  
 OTHERS 2x4 SP No.3(flat)

**BRACING**

TOP CHORD Structural wood sheathing directly applied or 5-10-6 oc purlins, except end verticals.  
 BOT CHORD Rigid ceiling directly applied or 10-0-0 oc bracing.

**REACTIONS** (lb/size) 13=922/0-3-8, (min. 0-1-8), 20=928/ Mechanical, (min. 0-1-8)

**FORCES** (lb) - Max. Comp./Max. Ten. - All forces 250 (lb) or less except when shown.

TOP CHORD 2-3=-2500/0, 3-4=-2500/0, 4-5=-3697/0, 5-6=-3697/0, 6-7=-3670/0, 7-8=-3670/0, 8-9=-3670/0, 9-10=-2501/0, 10-11=-2501/0

BOT CHORD 19-20=0/1440, 18-19=0/3228, 17-18=0/3228, 16-17=0/3697, 15-16=0/3697, 14-15=0/3226, 13-14=0/1440

WEBS 11-13=-1661/0, 2-20=-1665/0, 11-14=0/1239, 2-19=0/1237, 9-14=-846/0, 4-19=-851/0, 9-15=0/519, 4-17=0/722, 6-15=-418/299

**NOTES**

- Unbalanced floor live loads have been considered for this design.
- All plates are MT20 plates unless otherwise indicated.
- Refer to girder(s) for truss to truss connections.
- This truss is designed in accordance with the 2018 International Residential Code sections R502.11.1 and R802.10.2 and referenced standard ANSI/TPI 1.
- Recommend 2x6 strongbacks, on edge, spaced at 10-00-00 oc and fastened to each truss with 3-10d (0.131" X 3") nails. Strongbacks to be attached to walls at their outer ends or restrained by other means.
- CAUTION, Do not erect truss backwards.

**LOAD CASE(S)** Standard

Job Ashby	Truss F8GE	Truss Type Floor Supported Gable	Qty 1	Ply 1	Job Reference (optional)
--------------	---------------	-------------------------------------	----------	----------	--------------------------

Carter Components, Sanford, NC, user

Run: 8.53 S Mar 28 2022 Print: 8.530 S Mar 28 2022 MiTek Industries, Inc. Wed May 11 15:47:45

Page: 1

ID:GgjBMddRcHriTmpr?IULkezHcyl-p5p2TWIsUy\_8QgsOqAhJd?YRbyfE311c59fCT2zHY0S

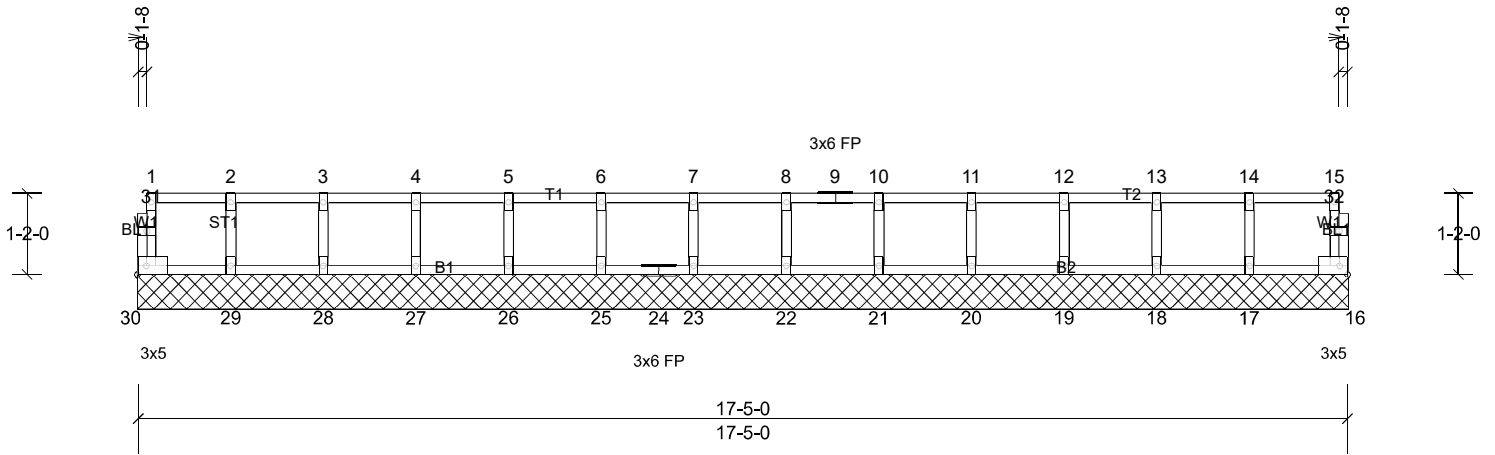

Scale = 1:33.2

Loading	(psf)	Spacing	2-0-0	CSI		DEFL	in	(loc)	l/defl	L/d	PLATES	GRIP
TCLL	40.0	Plate Grip DOL	1.00	TC	0.08	Vert(LL)	n/a	-	n/a	999	MT20	244/190
TCDL	10.0	Lumber DOL	1.00	BC	0.01	Vert(TL)	n/a	-	n/a	999		
BCLL	0.0	Rep Stress Incr	YES	WB	0.03	Horiz(TL)	0.00	16	n/a	n/a		
BCDL	5.0	Code	IRC2018/TPI2014	Matrix-MR							Weight: 73 lb	FT = 20%F, 11%E

**LUMBER**  
TOP CHORD 2x4 SP No.2(flat)  
BOT CHORD 2x4 SP No.2(flat)  
WEBS 2x4 SP No.3(flat)  
OTHERS 2x4 SP No.3(flat)

**BRACING**  
TOP CHORD Structural wood sheathing directly applied or 6-0-0 oc purlins, except end verticals.  
BOT CHORD Rigid ceiling directly applied or 10-0-0 oc bracing.

**REACTIONS** All bearings 17-5-0.  
(lb) - Max Grav All reactions 250 (lb) or less at joint(s) 16, 17, 18, 19, 20, 21, 22, 23, 25, 26, 27, 28, 29, 30

**FORCES** (lb) - Max. Comp./Max. Ten. - All forces 250 (lb) or less except when shown.

- NOTES**
- All plates are 1.5x3 MT20 unless otherwise indicated.
  - Gable requires continuous bottom chord bearing.
  - Truss to be fully sheathed from one face or securely braced against lateral movement (i.e. diagonal web).
  - Gable studs spaced at 1-4-0 oc.
  - This truss is designed in accordance with the 2018 International Residential Code sections R502.11.1 and R802.10.2 and referenced standard ANSI/TPI 1.
  - Recommend 2x6 strongbacks, on edge, spaced at 10-0-0-0 oc and fastened to each truss with 3-10d (0.131" X 3") nails. Strongbacks to be attached to walls at their outer ends or restrained by other means.

**LOAD CASE(S)** Standard

Job Ashby	Truss F9GR	Truss Type Floor Girder	Qty 1	Ply 1	Job Reference (optional)
--------------	---------------	----------------------------	----------	----------	--------------------------

Carter Components, Sanford, NC, user

Run: 8.53 S Mar 28 2022 Print: 8.530 S Mar 28 2022 MiTek Industries, Inc. Wed May 11 15:47:45

Page: 1

ID: Z1erq0iqzRkioqrBvj6?X6zHcyE-p5p2TWIsUy\_8QgsOqAhJd?YJ5yU53qRc59fCT2zHY0S

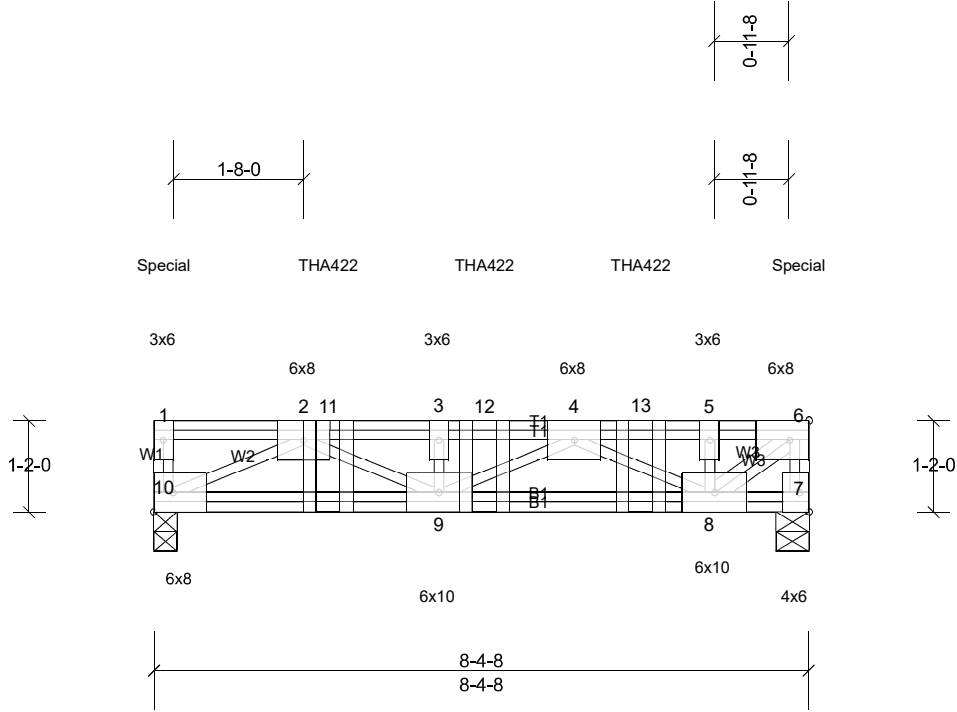

Scale = 1:29.5

Plate Offsets (X, Y): [6:0-3-0,Edge]

Loading	(psf)	Spacing	2-0-0	CSI		DEFL	in	(loc)	l/defl	L/d	PLATES	GRIP
TCLL	40.0	Plate Grip DOL	1.00	TC	0.62	Vert(LL)	-0.07	8-9	>999	360	MT20	244/190
TCDL	10.0	Lumber DOL	1.00	BC	0.72	Vert(CT)	-0.09	8-9	>999	240		
BCLL	0.0	Rep Stress Incr	NO	WB	0.84	Horz(CT)	0.02	7	n/a	n/a		
BCDL	5.0	Code	IRC2018/TPI2014	Matrix-MP							Weight: 70 lb	FT = 20%F, 11%E

**LUMBER**

TOP CHORD 2x4 SP No.2(flat)  
 BOT CHORD 2x4 SP No.2(flat)  
 WEBS 2x4 SP No.3(flat)

**BRACING**

TOP CHORD Structural wood sheathing directly applied or 6-0-0 oc purlins, except end verticals.  
 BOT CHORD Rigid ceiling directly applied or 10-0-0 oc bracing.

**REACTIONS** (lb/size) 7=2579/0-5-0, (min. 0-1-8), 10=2549/0-3-8, (min. 0-1-8)

**FORCES** (lb) - Max. Comp./Max. Ten. - All forces 250 (lb) or less except when shown.

TOP CHORD 1-10=-933/0, 6-7=-2571/0, 2-11=-4471/0, 3-11=-4471/0, 3-12=-4471/0, 4-12=-4471/0, 4-13=-2191/0, 5-13=-2191/0, 5-6=-2191/0  
 BOT CHORD 9-10=0/3095, 8-9=0/4192  
 WEBS 2-10=-3477/0, 2-9=0/1557, 3-9=-872/0, 4-9=0/315, 4-8=-2264/0, 5-8=-657/0, 6-8=0/2806

**NOTES**

- This truss is designed in accordance with the 2018 International Residential Code sections R502.11.1 and R802.10.2 and referenced standard ANSI/TPI 1.
- Recommend 2x6 strongbacks, on edge, spaced at 10-00-00 oc and fastened to each truss with 3-10d (0.131" X 3") nails. Strongbacks to be attached to walls at their outer ends or restrained by other means.
- Use Simpson Strong-Tie THA422 (6-16d Girder, 6-10d Truss) or equivalent spaced at 2-0-0 oc max. starting at 2-2-12 from the left end to 6-2-12 to connect truss(es) F8A (1 ply 2x4 SP) to back face of top chord.
- Fill all nail holes where hanger is in contact with lumber.
- Hanger(s) or other connection device(s) shall be provided sufficient to support concentrated load(s) 873 lb down at 0-1-8, and 877 lb down at 8-3-0 on top chord. The design/selection of such connection device(s) is the responsibility of others.
- In the LOAD CASE(S) section, loads applied to the face of the truss are noted as front (F) or back (B).

**LOAD CASE(S)** Standard

- Dead + Floor Live (balanced): Lumber Increase=1.00, Plate Increase=1.00  
 Uniform Loads (lb/ft)  
 Vert: 7-10=-10, 1-6=-100  
 Concentrated Loads (lb)  
 Vert: 6=-877 (B), 1=-873 (B), 11=-828 (B), 12=-828 (B), 13=-828 (B)

Job Ashby	Truss F10	Truss Type Floor	Qty 6	Ply 1	Job Reference (optional)
--------------	--------------	---------------------	----------	----------	--------------------------

Carter Components, Sanford, NC, user

Run: 8.53 S Mar 28 2022 Print: 8.530 S Mar 28 2022 MiTek Industries, Inc. Wed May 11 15:47:45

Page: 1

ID:s613kbbZKMT7cl4GJcxe7?zHcyO-p5p2TWIsUy\_8QgsOqAhJd?YJkyR03tbc59fCT2zHY0S

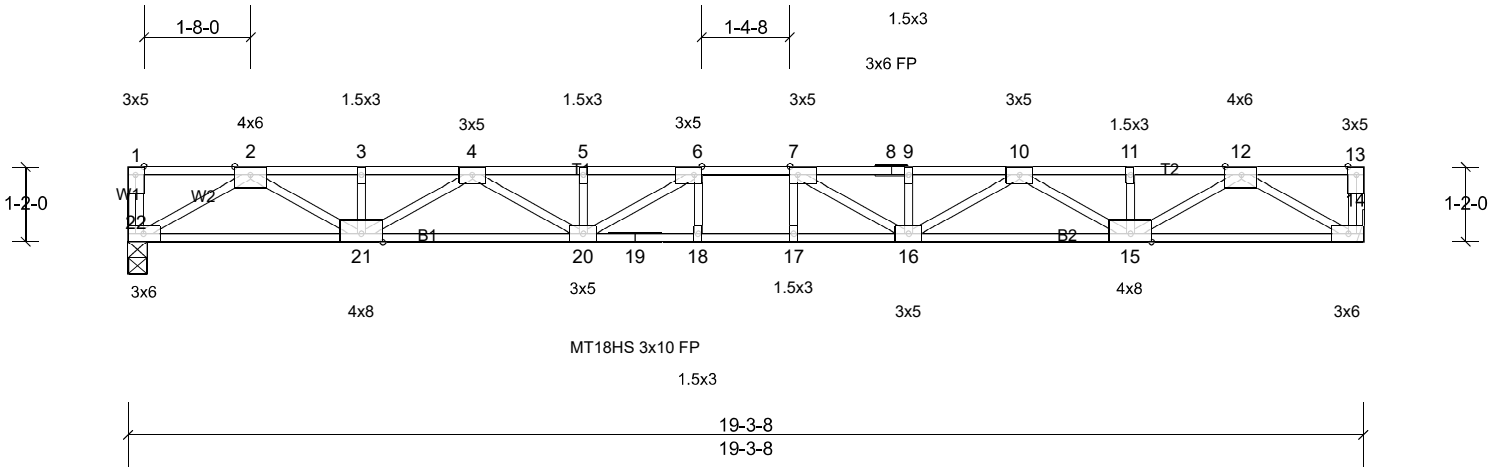

Scale = 1:36

Plate Offsets (X, Y): [6:0-1-8,Edge], [7:0-1-8,Edge]

Loading	(psf)	Spacing	2-0-0	CSI	DEFL	in	(loc)	l/defl	L/d	PLATES	GRIP	
TCLL	40.0	Plate Grip DOL	1.00	TC	0.58	Vert(LL)	-0.42	17-18	>548	360	MT18HS	244/190
TCDL	10.0	Lumber DOL	1.00	BC	0.92	Vert(CT)	-0.57	17-18	>398	240	MT20	244/190
BCLL	0.0	Rep Stress Incr	YES	WB	0.70	Horz(CT)	0.09	14	n/a	n/a		
BCDL	5.0	Code	IRC2018/TPI2014	Matrix-MSH							Weight: 99 lb	FT = 20%F, 11%E

**LUMBER**

TOP CHORD 2x4 SP No.2(flat)  
 BOT CHORD 2x4 SP No.1(flat)  
 WEBS 2x4 SP No.3(flat)

**BRACING**

TOP CHORD Structural wood sheathing directly applied or 5-3-4 oc purlins, except end verticals.  
 BOT CHORD Rigid ceiling directly applied or 10-0-0 oc bracing, Except: 2-2-0 oc bracing: 18-20,16-17.

**REACTIONS** (lb/size) 14=1047/ Mechanical, (min. 0-1-8), 22=1047/0-3-8, (min. 0-1-8)

**FORCES** (lb) - Max. Comp./Max. Ten. - All forces 250 (lb) or less except when shown.  
 TOP CHORD 2-3=-2903/0, 3-4=-2903/0, 4-5=-4452/0, 5-6=-4452/0, 6-7=-4756/0, 7-8=-4452/0, 8-9=-4452/0, 9-10=-4452/0, 10-11=-2903/0, 11-12=-2903/0  
 BOT CHORD 21-22=0/1647, 20-21=0/3824, 19-20=0/4756, 18-19=0/4756, 17-18=0/4756, 16-17=0/4756, 15-16=0/3824, 14-15=0/1647  
 WEBS 12-14=-1905/0, 2-22=-1905/0, 12-15=0/1466, 2-21=0/1466, 10-15=-1076/0, 4-21=-1076/0, 10-16=0/733, 4-20=0/733, 7-16=-712/137, 6-20=-712/137

**NOTES**

- 1) Unbalanced floor live loads have been considered for this design.
- 2) All plates are MT20 plates unless otherwise indicated.
- 3) All plates are 3x5 MT20 unless otherwise indicated.
- 4) Refer to girder(s) for truss to truss connections.
- 5) This truss is designed in accordance with the 2018 International Residential Code sections R502.11.1 and R802.10.2 and referenced standard ANSI/TPI 1.
- 6) Recommend 2x6 strongbacks, on edge, spaced at 10-00-00 oc and fastened to each truss with 3-10d (0.131" X 3") nails. Strongbacks to be attached to walls at their outer ends or restrained by other means.

**LOAD CASE(S)** Standard

Job Ashby	Truss F10GE	Truss Type Floor Supported Gable	Qty 1	Ply 1	Job Reference (optional)
--------------	----------------	-------------------------------------	----------	----------	--------------------------

Carter Components, Sanford, NC, user

Run: 8.53 S Mar 28 2022 Print: 8.530 S Mar 28 2022 MiTek Industries, Inc. Wed May 11 15:47:45

Page: 1

ID:GgjBMddRcHriTmpr?IULkezHcyL-p5p2TWIsUy\_8QgsOqAhJd?YRXYf6310c59fCT2zHY0S

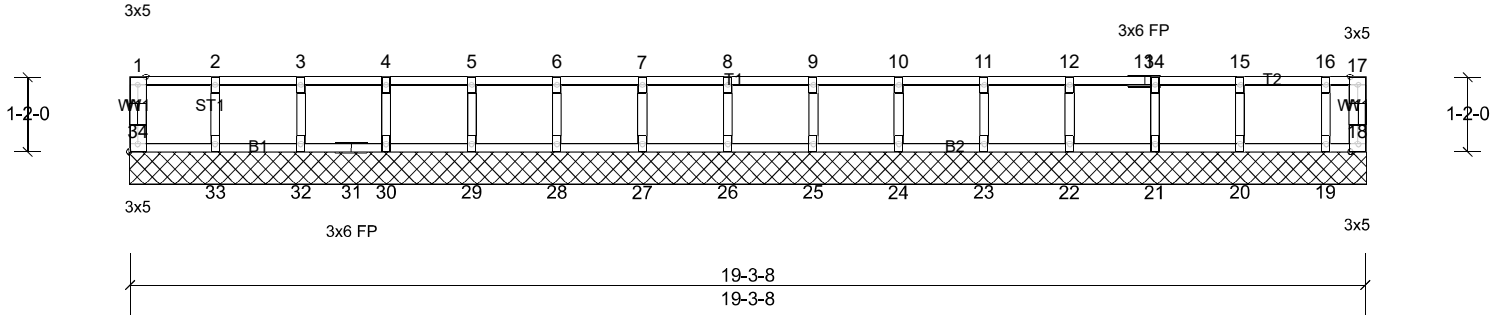

Scale = 1:36

Plate Offsets (X, Y): [34:Edge,0-1-8]

Loading	(psf)	Spacing	2-0-0	CSI		DEFL	in	(loc)	l/defl	L/d	PLATES	GRIP
TCLL	40.0	Plate Grip DOL	1.00	TC	0.08	Vert(LL)	n/a	-	n/a	999	MT20	244/190
TCDL	10.0	Lumber DOL	1.00	BC	0.02	Vert(TL)	n/a	-	n/a	999		
BCLL	0.0	Rep Stress Incr	YES	WB	0.03	Horiz(TL)	0.00	18	n/a	n/a		
BCDL	5.0	Code	IRC2018/TPI2014	Matrix-MR							Weight: 82 lb	FT = 20%F, 11%E

**LUMBER**

TOP CHORD 2x4 SP No.2(flat)  
 BOT CHORD 2x4 SP No.2(flat)  
 WEBS 2x4 SP No.3(flat)  
 OTHERS 2x4 SP No.3(flat)

**BRACING**

TOP CHORD Structural wood sheathing directly applied or 6-0-0 oc purlins, except end verticals.  
 BOT CHORD Rigid ceiling directly applied or 10-0-0 oc bracing.

**REACTIONS** All bearings 19-3-8.

(lb) - Max Grav All reactions 250 (lb) or less at joint(s) 18, 19, 20, 21, 22, 23, 24, 25, 26, 27, 28, 29, 30, 32, 33, 34

**FORCES** (lb) - Max. Comp./Max. Ten. - All forces 250 (lb) or less except when shown.

**NOTES**

- All plates are 1.5x3 MT20 unless otherwise indicated.
- Gable requires continuous bottom chord bearing.
- Truss to be fully sheathed from one face or securely braced against lateral movement (i.e. diagonal web).
- Gable studs spaced at 1-4-0 oc.
- This truss is designed in accordance with the 2018 International Residential Code sections R502.11.1 and R802.10.2 and referenced standard ANSI/TPI 1.
- Recommend 2x6 strongbacks, on edge, spaced at 10-00-00 oc and fastened to each truss with 3-10d (0.131" X 3") nails. Strongbacks to be attached to walls at their outer ends or restrained by other means.

**LOAD CASE(S)** Standard

Job Ashby	Truss F11	Truss Type Floor	Qty 6	Ply 1	Job Reference (optional)
--------------	--------------	---------------------	----------	----------	--------------------------

Carter Components, Sanford, NC, user

Run: 8.53 S Mar 28 2022 Print: 8.530 S Mar 28 2022 MiTek Industries, Inc. Wed May 11 15:47:45

Page: 1

ID:s613kbbZKMT7cl4GJcxe7?zHcyO-p5p2TWIsUy\_8QgsOqAhJd?YPNyD330Ac59fCT2zHY0S

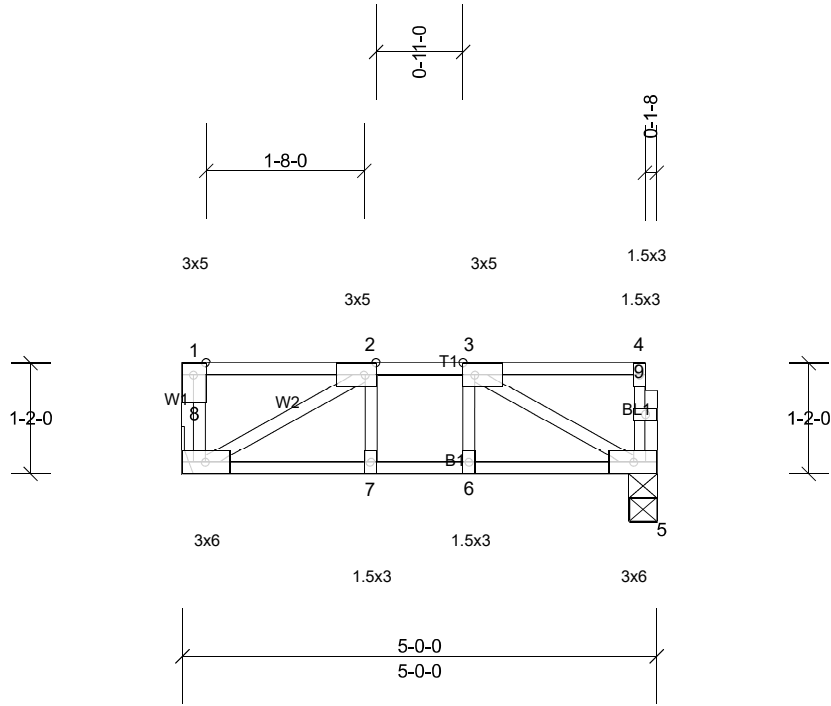

Scale = 1:24.3

Plate Offsets (X, Y): [2:0-1-8,Edge], [3:0-1-8,Edge]

Loading	(psf)	Spacing	2-0-0	CSI	DEFL	in	(loc)	l/defl	L/d	PLATES	GRIP	
TCLL	40.0	Plate Grip DOL	1.00	TC	0.22	Vert(LL)	-0.01	7-8	>999	360	MT20	244/190
TCDL	10.0	Lumber DOL	1.00	BC	0.15	Vert(CT)	-0.01	7-8	>999	240		
BCLL	0.0	Rep Stress Incr	YES	WB	0.09	Horz(CT)	0.00	5	n/a	n/a		
BCDL	5.0	Code	IRC2018/TPI2014	Matrix-MSH							Weight: 28 lb	FT = 20%F, 11%E

**LUMBER**  
 TOP CHORD 2x4 SP No.2(flat)  
 BOT CHORD 2x4 SP No.2(flat)  
 WEBS 2x4 SP No.3(flat)  
 OTHERS 2x4 SP No.3(flat)

**BRACING**  
 TOP CHORD Structural wood sheathing directly applied or 5-0-0 oc purlins, except end verticals.  
 BOT CHORD Rigid ceiling directly applied or 10-0-0 oc bracing.

**REACTIONS** (lb/size) 5=255/0-3-8, (min. 0-1-8), 8=261/ Mechanical, (min. 0-1-8)

**FORCES** (lb) - Max. Comp./Max. Ten. - All forces 250 (lb) or less except when shown.  
 TOP CHORD 2-3=-308/0  
 BOT CHORD 7-8=0/308, 6-7=0/308, 5-6=0/308  
 WEBS 3-5=-348/0, 2-8=-353/0

- NOTES**
- Unbalanced floor live loads have been considered for this design.
  - Refer to girder(s) for truss to truss connections.
  - This truss is designed in accordance with the 2018 International Residential Code sections R502.11.1 and R802.10.2 and referenced standard ANSI/TPI 1.
  - Recommend 2x6 strongbacks, on edge, spaced at 10-00-00 oc and fastened to each truss with 3-10d (0.131" X 3") nails. Strongbacks to be attached to walls at their outer ends or restrained by other means.
  - CAUTION, Do not erect truss backwards.

**LOAD CASE(S)** Standard



Job Ashby	Truss F11GE	Truss Type Floor Supported Gable	Qty 2	Ply 1	Job Reference (optional)
--------------	----------------	-------------------------------------	----------	----------	--------------------------

Carter Components, Sanford, NC, user

Run: 8.53 S Mar 28 2022 Print: 8.530 S Mar 28 2022 MiTek Industries, Inc. Wed May 11 15:47:45

Page: 1

ID:GgjBMddRcHriTmpr?IULkezHcyL-p5p2TWIsUy\_8QgsOqAhJd?YRXYfA310c59fCT2zHY0S

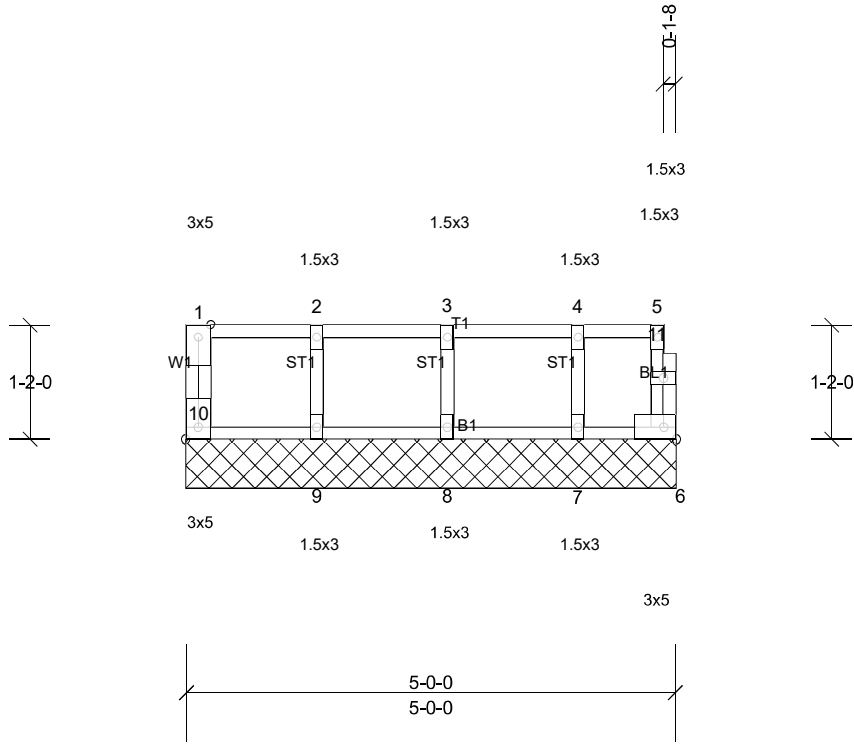

Scale = 1:23.6

Plate Offsets (X, Y): [10:Edge,0-1-8]

Loading	(psf)	Spacing	2-0-0	CSI		DEFL	in	(loc)	l/defl	L/d	PLATES	GRIP
TCLL	40.0	Plate Grip DOL	1.00	TC	0.08	Vert(LL)	n/a	-	n/a	999	MT20	244/190
TCDL	10.0	Lumber DOL	1.00	BC	0.02	Vert(TL)	n/a	-	n/a	999		
BCLL	0.0	Rep Stress Incr	YES	WB	0.03	Horiz(TL)	0.00	6	n/a	n/a		
BCDL	5.0	Code	IRC2018/TPI2014	Matrix-MR							Weight: 24 lb	FT = 20%F, 11%E

**LUMBER**

TOP CHORD 2x4 SP No.2(flat)  
 BOT CHORD 2x4 SP No.2(flat)  
 WEBS 2x4 SP No.3(flat)  
 OTHERS 2x4 SP No.3(flat)

**BRACING**

TOP CHORD Structural wood sheathing directly applied or 5-0-0 oc purlins, except end verticals.  
 BOT CHORD Rigid ceiling directly applied or 10-0-0 oc bracing.

**REACTIONS** All bearings 5-0-0.

(lb) - Max Grav All reactions 250 (lb) or less at joint(s) 6, 7, 8, 9, 10

**FORCES**

(lb) - Max. Comp./Max. Ten. - All forces 250 (lb) or less except when shown.

**NOTES**

- All plates are 1.5x3 MT20 unless otherwise indicated.
- Gable requires continuous bottom chord bearing.
- Truss to be fully sheathed from one face or securely braced against lateral movement (i.e. diagonal web).
- Gable studs spaced at 1'-4" oc.
- This truss is designed in accordance with the 2018 International Residential Code sections R502.11.1 and R802.10.2 and referenced standard ANSI/TPI 1.
- Recommend 2x6 strongbacks, on edge, spaced at 10-00-00 oc and fastened to each truss with 3-10d (0.131" X 3") nails. Strongbacks to be attached to walls at their outer ends or restrained by other means.
- CAUTION, Do not erect truss backwards.

**LOAD CASE(S)** Standard