

**Trenco**

818 Soundside Rd  
Edenton, NC 27932

Re: ELV B CP 3CG  
Chesapeake Homes 628 Roof

The truss drawing(s) referenced below have been prepared by Truss Engineering Co. under my direct supervision based on the parameters provided by Builders FirstSource-Apex,NC.

Pages or sheets covered by this seal: I61390496 thru I61390528

My license renewal date for the state of North Carolina is December 31, 2023.

North Carolina COA: C-0844



October 16,2023

Gilbert, Eric

**IMPORTANT NOTE:** The seal on these truss component designs is a certification that the engineer named is licensed in the jurisdiction(s) identified and that the designs comply with ANSI/TPI 1. These designs are based upon parameters shown (e.g., loads, supports, dimensions, shapes and design codes), which were given to MiTek or TRENCO. Any project specific information included is for MiTek's or TRENCO's customers file reference purpose only, and was not taken into account in the preparation of these designs. MiTek or TRENCO has not independently verified the applicability of the design parameters or the designs for any particular building. Before use, the building designer should verify applicability of design parameters and properly incorporate these designs into the overall building design per ANSI/TPI 1, Chapter 2.

Job ELV B CP 3CG	Truss A01	Truss Type Common	Qty 10	Ply 1	Chesapeake Homes 628 Roof Job Reference (optional)	161390496
---------------------	--------------	----------------------	-----------	----------	---	-----------

Builders FirstSource (Apex, NC), Apex, NC - 27523,

Run: 8.63 S Aug 30 2023 Print: 8.630 S Aug 30 2023 MiTek Industries, Inc. Thu Oct 12 18:28:10  
ID:Be0VNTUdJV1PMEHyOydXfzIBVu-RfC?PsB70Hq3NSgPqnLw3uITXbGKWRCDoI7J4zJC?f

Page: 1

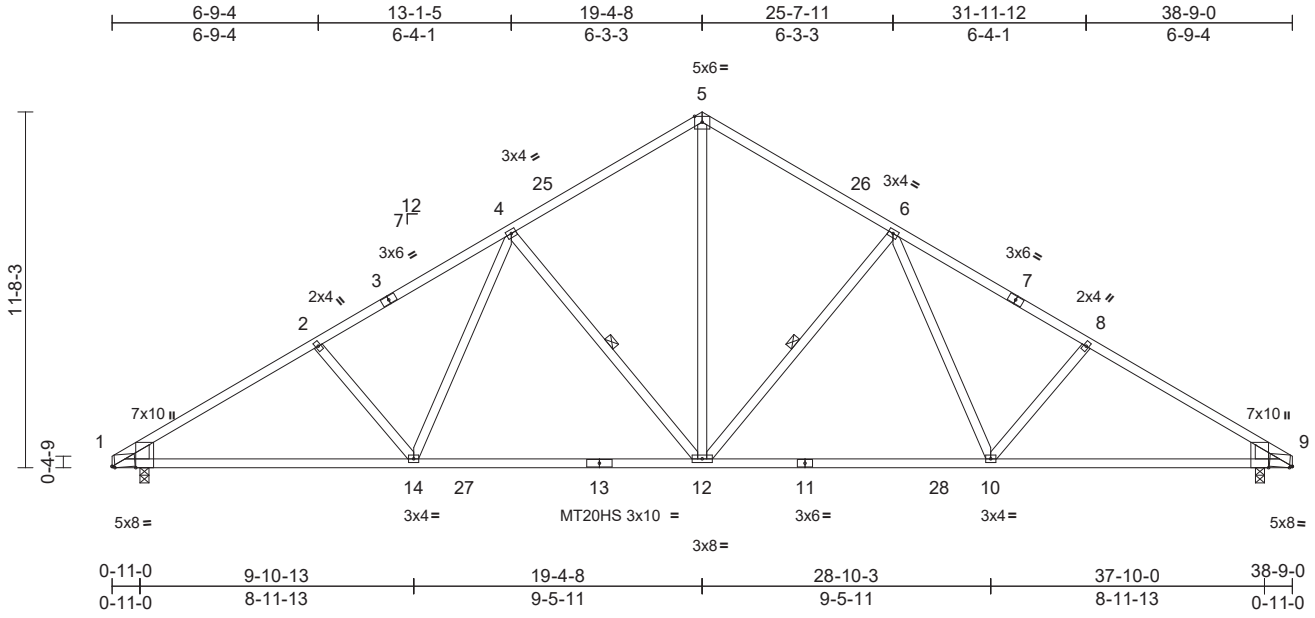

Scale = 1:75.6

Plate Offsets (X, Y): [1:0-1-1,Edge], [1:0-0-8,Edge], [9:0-1-1,Edge], [9:0-0-8,Edge]

Loading	(psf)	Spacing	2-0-0	CSI	DEFL	in	(loc)	l/defl	L/d	PLATES	GRIP	
TCLL (roof)	20.0	Plate Grip DOL	1.00	TC	0.92	Vert(LL)	-0.36	12-14	>999	240	MT20	244/190
Snow (Ps/Pf)	13.2/20.0	Lumber DOL	1.15	BC	0.96	Vert(CT)	-0.63	10-12	>735	180	MT20HS	187/143
TCDL	10.0	Rep Stress Incr	YES	WB	0.49	Horz(CT)	0.10	9	n/a	n/a		
BCLL	0.0*	Code	IRC2015/TPI2014	Matrix-MS								
BCDL	10.0											
											Weight: 212 lb	FT = 20%

**LUMBER**  
TOP CHORD 2x4 SP No.2 \*Except\* 1-3,7-9:2x4 SP No.1  
BOT CHORD 2x4 SP No.1  
WEBS 2x4 SP No.3  
WEDGE Left: 2x6 SP No.2  
Right: 2x6 SP DSS

**BRACING**  
TOP CHORD Structural wood sheathing directly applied or 2-2-0 oc purlins.  
BOT CHORD Rigid ceiling directly applied or 2-2-0 oc bracing.  
WEBS 1 Row at midpt 6-12, 4-12

**REACTIONS** (size) 1=0-3-8, 9=0-3-8  
Max Horiz 1=219 (LC 13)  
Max Uplift 1=-38 (LC 16), 9=-38 (LC 17)  
Max Grav 1=1555 (LC 29), 9=1555 (LC 30)

**FORCES** (lb) - Maximum Compression/Maximum Tension  
TOP CHORD 1-2=-2250/179, 2-4=-2067/198,  
4-5=-1554/225, 5-6=-1554/225,  
6-8=-2068/198, 8-9=-2250/179  
BOT CHORD 1-14=-181/1983, 12-14=-42/1722,  
10-12=0/1611, 9-10=-73/1819  
WEBS 5-12=-118/1192, 6-12=-627/177,  
6-10=-5/378, 8-10=-212/148, 2-14=-212/148,  
4-14=-5/378, 4-12=-627/177

- TCLL: ASCE 7-10; Pr=20.0 psf (roof live load: Lumber DOL=1.15 Plate DOL=1.00); Pf=20.0 psf (flat roof snow); Ps=13.2 psf (roof snow: Lumber DOL=1.15 Plate DOL=1.00); Category II; Exp B; Fully Exp.; Ct=1.10; Unobstructed slippery surface
- Roof design snow load has been reduced to account for slope.
- Unbalanced snow loads have been considered for this design.
- All plates are MT20 plates unless otherwise indicated.
- This truss has been designed for a 10.0 psf bottom chord live load nonconcurrent with any other live loads.
- \* This truss has been designed for a live load of 20.0psf on the bottom chord in all areas where a rectangle 3-06-00 tall by 2-00-00 wide will fit between the bottom chord and any other members, with BCDL = 10.0psf.
- All bearings are assumed to be SP No.1 crushing capacity of 565 psi.
- Provide mechanical connection (by others) of truss to bearing plate capable of withstanding 38 lb uplift at joint 1 and 38 lb uplift at joint 9.
- This truss is designed in accordance with the 2015 International Residential Code sections R502.11.1 and R802.10.2 and referenced standard ANSI/TPI 1.

**LOAD CASE(S)** Standard

- NOTES**
- Unbalanced roof live loads have been considered for this design.
  - Wind: ASCE 7-10; Vult=115mph (3-second gust) Vasd=91mph; TCDL=6.0psf; BCDL=6.0psf; h=30ft; Cat. II; Exp B; Enclosed; MWFRS (envelope) exterior zone and C-C Exterior (2) zone; cantilever left and right exposed; end vertical left and right exposed; C-C for members and forces & MWFRS for reactions shown; Lumber DOL=1.60 plate grip DOL=1.33



October 16, 2023

**WARNING - Verify design parameters and READ NOTES ON THIS AND INCLUDED MITEK REFERENCE PAGE MII-7473 rev. 1/2/2023 BEFORE USE.**  
Design valid for use only with MiTek® connectors. This design is based only upon parameters shown, and is for an individual building component, not a truss system. Before use, the building designer must verify the applicability of design parameters and properly incorporate this design into the overall building design. Bracing indicated is to prevent buckling of individual truss web and/or chord members only. Additional temporary and permanent bracing is always required for stability and to prevent collapse with possible personal injury and property damage. For general guidance regarding the fabrication, storage, delivery, erection and bracing of trusses and truss systems, see **ANSI/TPI1 Quality Criteria and DSB-22** available from Truss Plate Institute (www.tpinst.org) and **BCSI Building Component Safety Information** available from the Structural Building Component Association (www.sbcacomponents.com)



Job ELV B CP 3CG	Truss A01G	Truss Type Common Supported Gable	Qty 1	Ply 1	Chesapeake Homes 628 Roof Job Reference (optional)	I61390497
---------------------	---------------	--------------------------------------	----------	----------	---	-----------

Builders FirstSource (Apex, NC), Apex, NC - 27523,

Run: 8.63 S Aug 30 2023 Print: 8.630 S Aug 30 2023 MiTek Industries, Inc. Thu Oct 12 18:28:12  
ID:s1rkApFouah?fl3epONNzXlBUe-RfC?PsB70Hq3NSgPqnL8w3lTXbGKwRcDoi7J4zJC?f

Page: 1

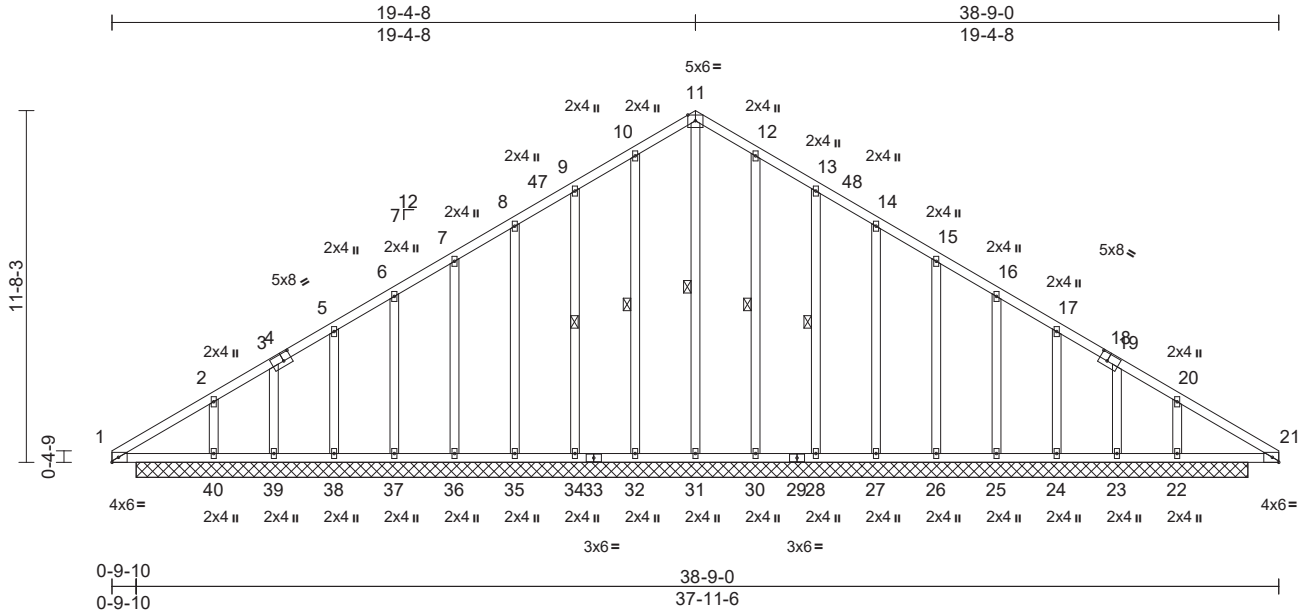

Scale = 1:76.5  
Plate Offsets (X, Y): [3:0-3-4,0-3-0], [18:0-3-4,0-3-0]

Loading	(psf)	Spacing	2-0-0	CSI	DEFL	in	(loc)	l/defl	L/d	PLATES	GRIP
TCLL (roof)	20.0	Plate Grip DOL	1.00	TC	0.27	Vert(LL)	n/a	-	n/a	999	244/190
Snow (Ps/Pf)	13.2/20.0	Lumber DOL	1.15	BC	0.25	Vert(TL)	n/a	-	n/a	999	
TCDL	10.0	Rep Stress Incr	YES	WB	0.21	Horiz(TL)	-0.01	22	n/a	n/a	
BCLL	0.0*	Code	IRC2015/TPI2014	Matrix-MS							
BCDL	10.0										
Weight: 281 lb											FT = 20%

LUMBER	FORCES	NOTES
<b>TOP CHORD</b> 2x4 SP No.2 <b>BOT CHORD</b> 2x4 SP No.2 <b>OTHERS</b> 2x4 SP No.3 <b>BRACING</b> <b>TOP CHORD</b> Structural wood sheathing directly applied or 10-0-0 oc purlins. <b>BOT CHORD</b> Rigid ceiling directly applied or 6-0-0 oc bracing. <b>WEBS</b> 1 Row at midpt 11-31, 10-32, 9-34, 12-30, 13-28 <b>REACTIONS</b> (size) 22=36-11-0, 23=36-11-0, 24=36-11-0, 25=36-11-0, 26=36-11-0, 27=36-11-0, 28=36-11-0, 30=36-11-0, 31=36-11-0, 32=36-11-0, 34=36-11-0, 35=36-11-0, 36=36-11-0, 37=36-11-0, 38=36-11-0, 39=36-11-0, 40=36-11-0 Max Horiz 40=-219 (LC 12) Max Uplift 22=-78 (LC 16), 23=-132 (LC 12), 24=-16 (LC 16), 25=-38 (LC 17), 26=-32 (LC 17), 27=-32 (LC 17), 28=-39 (LC 17), 30=-20 (LC 17), 32=-21 (LC 16), 34=-39 (LC 16), 35=-32 (LC 16), 36=-32 (LC 16), 37=-39 (LC 16), 38=-17 (LC 17), 39=-142 (LC 13), 40=-86 (LC 17) Max Grav 22=392 (LC 34), 23=186 (LC 15), 24=196 (LC 34), 25=163 (LC 30), 26=162 (LC 34), 27=163 (LC 30), 28=192 (LC 23), 30=229 (LC 23), 31=358 (LC 32), 32=229 (LC 22), 34=192 (LC 22), 35=163 (LC 29), 36=162 (LC 33), 37=164 (LC 29), 38=196 (LC 33), 39=195 (LC 14), 40=392 (LC 33)	<b>(lb) - Maximum Compression/Maximum Tension</b> <b>TOP CHORD</b> 1-2=-79/288, 2-3=-81/270, 3-5=-27/255, 5-6=-10/251, 6-7=0/259, 7-8=-28/268, 8-9=-60/276, 9-10=-93/288, 10-11=-124/308, 11-12=-124/308, 12-13=-93/285, 13-14=-60/272, 14-15=-28/264, 15-16=0/256, 16-17=-3/247, 17-19=-20/250, 19-20=-73/263, 20-21=-75/291 <b>BOT CHORD</b> 1-40=-229/101, 39-40=-225/98, 38-39=-225/98, 37-38=-225/98, 36-37=-225/98, 35-36=-225/98, 34-35=-225/98, 32-34=-225/98, 31-32=-225/98, 30-31=-225/98, 28-30=-225/98, 27-28=-225/98, 26-27=-225/98, 25-26=-225/98, 24-25=-225/98, 23-24=-225/98, 22-23=-225/98, 21-22=-225/98 <b>WEBS</b> 11-31=-318/26, 10-32=-189/45, 9-34=-152/63, 8-35=-123/56, 7-36=-122/57, 6-37=-122/59, 5-38=-136/53, 3-39=-130/95, 2-40=-238/68, 12-30=-189/44, 13-28=-152/63, 14-27=-123/56, 15-26=-122/57, 16-25=-122/59, 17-24=-136/53, 19-23=-127/92, 20-22=-238/66	<b>NOTES</b> 1) Unbalanced roof live loads have been considered for this design. 2) Wind: ASCE 7-10; Vult=115mph (3-second gust) Vasd=91mph; TCDL=6.0psf; BCDL=6.0psf; h=30ft; Cat. II; Exp B; Enclosed; MWFRS (envelope) exterior zone and C-C Exterior (2) zone; cantilever left and right exposed ; end vertical left and right exposed; C-C for members and forces & MWFRS for reactions shown; Lumber DOL=1.60 plate grip DOL=1.33 3) Truss designed for wind loads in the plane of the truss only. For studs exposed to wind (normal to the face), see Standard Industry Gable End Details as applicable, or consult qualified building designer as per ANSI/TPI 1. 4) TCLL: ASCE 7-10; Pr=20.0 psf (roof live load: Lumber DOL=1.15 Plate DOL=1.00); Pf=20.0 psf (flat roof snow); Ps=13.2 psf (roof snow: Lumber DOL=1.15 Plate DOL=1.00); Category II; Exp B; Fully Exp.; Ct=1.10; Unobstructed slippery surface 5) Roof design snow load has been reduced to account for slope. 6) Unbalanced snow loads have been considered for this design. 7) Gable studs spaced at 2-0-0 oc. 8) This truss has been designed for a 10.0 psf bottom chord live load nonconcurrent with any other live loads. 9) * This truss has been designed for a live load of 20.0psf on the bottom chord in all areas where a rectangle 3-06-00 tall by 2-00-00 wide will fit between the bottom chord and any other members. 10) All bearings are assumed to be SP No.2 crushing capacity of 565 psi.



October 16, 2023

Continued on page 2

**WARNING - Verify design parameters and READ NOTES ON THIS AND INCLUDED MITEK REFERENCE PAGE MII-7473 rev. 1/2/2023 BEFORE USE.**  
 Design valid for use only with MiTek® connectors. This design is based only upon parameters shown, and is for an individual building component, not a truss system. Before use, the building designer must verify the applicability of design parameters and properly incorporate this design into the overall building design. Bracing indicated is to prevent buckling of individual truss web and/or chord members only. Additional temporary and permanent bracing is always required for stability and to prevent collapse with possible personal injury and property damage. For general guidance regarding the fabrication, storage, delivery, erection and bracing of trusses and truss systems, see **ANSI/TPI1 Quality Criteria and DSB-22** available from Truss Plate Institute (www.tpinst.org) and **BCSI Building Component Safety Information** available from the Structural Building Component Association (www.sbcacomponents.com)

ENGINEERING BY  
**TRENCO**  
 A MiTek Affiliate  
 818 Soundside Road  
 Edenton, NC 27932

Job	Truss	Truss Type	Qty	Ply	Chesapeake Homes 628 Roof
ELV B CP 3CG	A01G	Common Supported Gable	1	1	I61390497
					Job Reference (optional)

Builders FirstSource (Apex, NC), Apex, NC - 27523,

Run: 8.63 S Aug 30 2023 Print: 8.630 S Aug 30 2023 MiTek Industries, Inc. Thu Oct 12 18:28:12  
 ID:s1rkApFfouah?l3epONnXzlBUe-RfC?PsB70Hq3NSgPqnL8w3ulTXbGKWrCDoi7J4zJC?f

Page: 2

- 11) Provide mechanical connection (by others) of truss to bearing plate capable of withstanding 21 lb uplift at joint 32, 39 lb uplift at joint 34, 32 lb uplift at joint 35, 32 lb uplift at joint 36, 39 lb uplift at joint 37, 17 lb uplift at joint 38, 142 lb uplift at joint 39, 86 lb uplift at joint 40, 20 lb uplift at joint 30, 39 lb uplift at joint 28, 32 lb uplift at joint 27, 32 lb uplift at joint 26, 38 lb uplift at joint 25, 16 lb uplift at joint 24, 132 lb uplift at joint 23 and 78 lb uplift at joint 22.
- 12) Non Standard bearing condition. Review required.
- 13) This truss is designed in accordance with the 2015 International Residential Code sections R502.11.1 and R802.10.2 and referenced standard ANSI/TPI 1.

**LOAD CASE(S)** Standard

**WARNING - Verify design parameters and READ NOTES ON THIS AND INCLUDED MITEK REFERENCE PAGE MII-7473 rev. 1/2/2023 BEFORE USE.**

Design valid for use only with MiTek® connectors. This design is based only upon parameters shown, and is for an individual building component, not a truss system. Before use, the building designer must verify the applicability of design parameters and properly incorporate this design into the overall building design. Bracing indicated is to prevent buckling of individual truss web and/or chord members only. Additional temporary and permanent bracing is always required for stability and to prevent collapse with possible personal injury and property damage. For general guidance regarding the fabrication, storage, delivery, erection and bracing of trusses and truss systems, see **ANSI/TPI1 Quality Criteria and DSB-22** available from Truss Plate Institute ([www.tpinst.org](http://www.tpinst.org)) and **BCSI Building Component Safety Information** available from the Structural Building Component Association ([www.sbcacomponents.com](http://www.sbcacomponents.com))



818 Soundside Road  
 Edenton, NC 27932

Job ELV B CP 3CG	Truss A03	Truss Type Common	Qty 5	Ply 1	Chesapeake Homes 628 Roof Job Reference (optional)	161390498
---------------------	--------------	----------------------	----------	----------	---	-----------

Builders FirstSource (Apex, NC), Apex, NC - 27523,

Run: 8.63 S Aug 30 2023 Print: 8.630 S Aug 30 2023 MiTek Industries, Inc. Thu Oct 12 18:28:13  
ID:C7?LnpuvKg7Js3HSTnYjRzIBZ5-RfC?PsB70Hq3NSgPqnL8w3uITXbGKWrCDoi7J4zJC7f

Page: 1

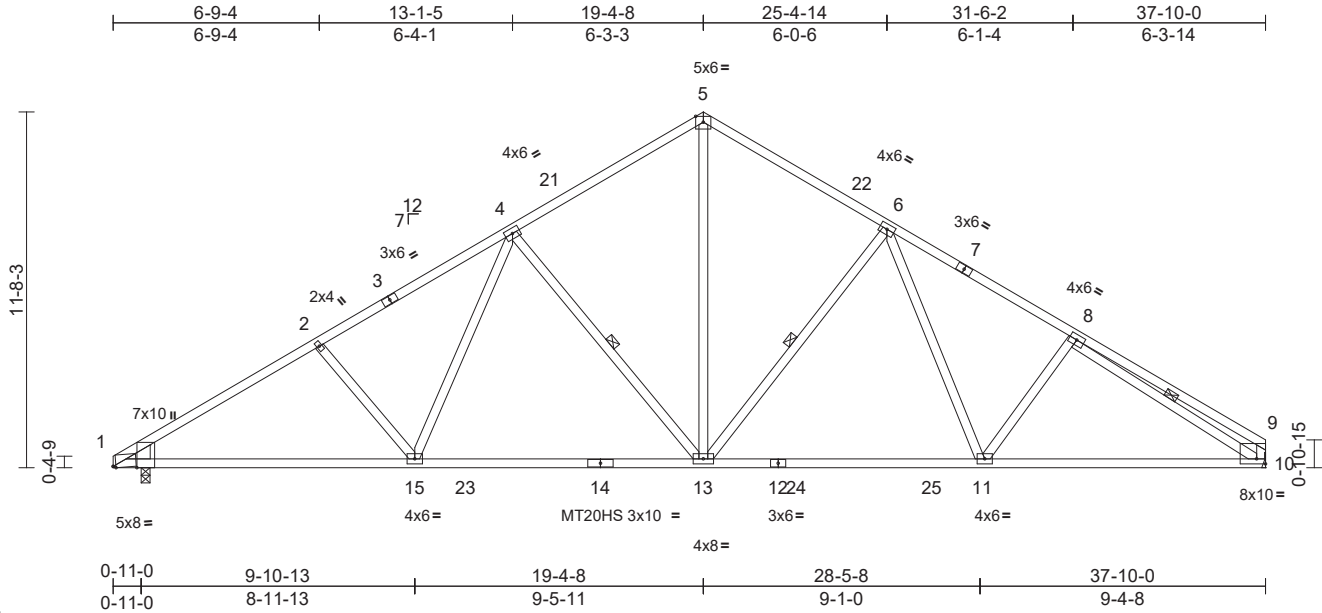

Scale = 1:75.6

Plate Offsets (X, Y): [1:0-1-1,Edge], [1:0-0-8,Edge], [10:Edge,0-2-0]

Loading	(psf)	Spacing	2-0-0	CSI	DEFL	in	(loc)	l/defl	L/d	PLATES	GRIP	
TCLL (roof)	20.0	Plate Grip DOL	1.00	TC	0.93	Vert(LL)	-0.34	13-15	>999	240	MT20	244/190
Snow (Ps/Pf)	13.2/20.0	Lumber DOL	1.15	BC	0.95	Vert(CT)	-0.61	13-15	>742	180	MT20HS	187/143
TCDL	10.0	Rep Stress Incr	YES	WB	0.59	Horz(CT)	0.09	10	n/a	n/a		
BCLL	0.0*	Code	IRC2015/TPI2014	Matrix-MS								
BCDL	10.0											
											Weight: 219 lb	FT = 20%

**LUMBER**  
TOP CHORD 2x4 SP No.2 \*Except\* 1-3:2x4 SP No.1  
BOT CHORD 2x4 SP No.1  
WEBS 2x4 SP No.3  
WEDGE Left: 2x6 SP DSS

**BRACING**  
TOP CHORD Structural wood sheathing directly applied or 2-2-0 oc purlins, except end verticals.  
BOT CHORD Rigid ceiling directly applied or 10-0-0 oc bracing, Except:  
2-2-0 oc bracing: 1-15.  
WEBS 1 Row at midpt 8-10, 6-13, 4-13

**REACTIONS** (size) 1=0-3-8, 10= Mechanical  
Max Horiz 1=226 (LC 15)  
Max Uplift 1=-38 (LC 16), 10=-32 (LC 17)  
Max Grav 1=1551 (LC 29), 10=1476 (LC 30)

**FORCES** (lb) - Maximum Compression/Maximum Tension  
TOP CHORD 1-2=-2246/178, 2-4=-2063/197,  
4-5=-1544/225, 5-6=-1536/226,  
6-8=-2091/203, 8-9=-480/80, 9-10=-371/75  
BOT CHORD 1-15=-182/1978, 13-15=-43/1716,  
11-13=-16/1589, 10-11=-96/1795  
WEBS 5-13=-119/1178, 8-10=-1807/112,  
6-13=-618/170, 6-11=-12/436,  
8-11=-207/159, 2-15=-212/148, 4-15=-4/385,  
4-13=-630/176

- TCLL: ASCE 7-10; Pr=20.0 psf (roof live load: Lumber DOL=1.15 Plate DOL=1.00); Pf=20.0 psf (flat roof snow); Ps=13.2 psf (roof snow: Lumber DOL=1.15 Plate DOL=1.00); Category II; Exp B; Fully Exp.; Ct=1.10; Unobstructed slippery surface
- Roof design snow load has been reduced to account for slope.
- Unbalanced snow loads have been considered for this design.
- All plates are MT20 plates unless otherwise indicated.
- This truss has been designed for a 10.0 psf bottom chord live load nonconcurrent with any other live loads.
- \* This truss has been designed for a live load of 20.0psf on the bottom chord in all areas where a rectangle 3-06-00 tall by 2-00-00 wide will fit between the bottom chord and any other members, with BCDL = 10.0psf.
- Bearings are assumed to be: Joint 1 SP No.1 crushing capacity of 565 psi.
- Refer to girder(s) for truss to truss connections.
- Provide mechanical connection (by others) of truss to bearing plate capable of withstanding 38 lb uplift at joint 1 and 32 lb uplift at joint 10.
- This truss is designed in accordance with the 2015 International Residential Code sections R502.11.1 and R802.10.2 and referenced standard ANSI/TPI 1.

**LOAD CASE(S)** Standard

- NOTES**
- Unbalanced roof live loads have been considered for this design.
  - Wind: ASCE 7-10; Vult=115mph (3-second gust) Vasd=91mph; TCDL=6.0psf; BCDL=6.0psf; h=30ft; Cat. II; Exp B; Enclosed; MWFRS (envelope) exterior zone and C-C Exterior (2) zone; cantilever left and right exposed; end vertical left and right exposed; C-C for members and forces & MWFRS for reactions shown; Lumber DOL=1.60 plate grip DOL=1.33

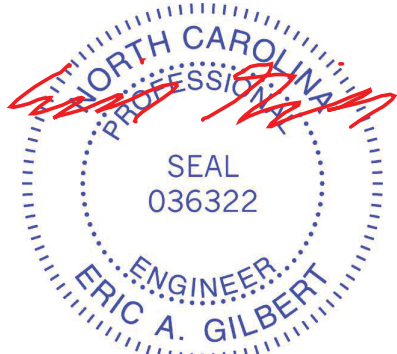

October 16, 2023

**WARNING - Verify design parameters and READ NOTES ON THIS AND INCLUDED MITEK REFERENCE PAGE MII-7473 rev. 1/2/2023 BEFORE USE.**  
Design valid for use only with MiTek® connectors. This design is based only upon parameters shown, and is for an individual building component, not a truss system. Before use, the building designer must verify the applicability of design parameters and properly incorporate this design into the overall building design. Bracing indicated is to prevent buckling of individual truss web and/or chord members only. Additional temporary and permanent bracing is always required for stability and to prevent collapse with possible personal injury and property damage. For general guidance regarding the fabrication, storage, delivery, erection and bracing of trusses and truss systems, see **ANSI/TPI1 Quality Criteria and DSB-22** available from Truss Plate Institute (www.tpinst.org) and **BCSI Building Component Safety Information** available from the Structural Building Component Association (www.sbcacomponents.com)



818 Soundside Road  
Edenton, NC 27932

Job ELV B CP 3CG	Truss A03G	Truss Type Common Supported Gable	Qty 1	Ply 1	Chesapeake Homes 628 Roof Job Reference (optional)	I61390499
---------------------	---------------	--------------------------------------	----------	----------	---	-----------

Builders FirstSource (Apex, NC), Apex, NC - 27523,

Run: 8.63 S Aug 30 2023 Print: 8.630 S Aug 30 2023 MiTek Industries, Inc. Thu Oct 12 18:28:14  
ID:G9akxTit4GFRxLgAJ5Y3mKzIBU3-RfC?PsB70Hq3NSgPqnL8w3uITxGKWrCdoi7J4zJC7f

Page: 1

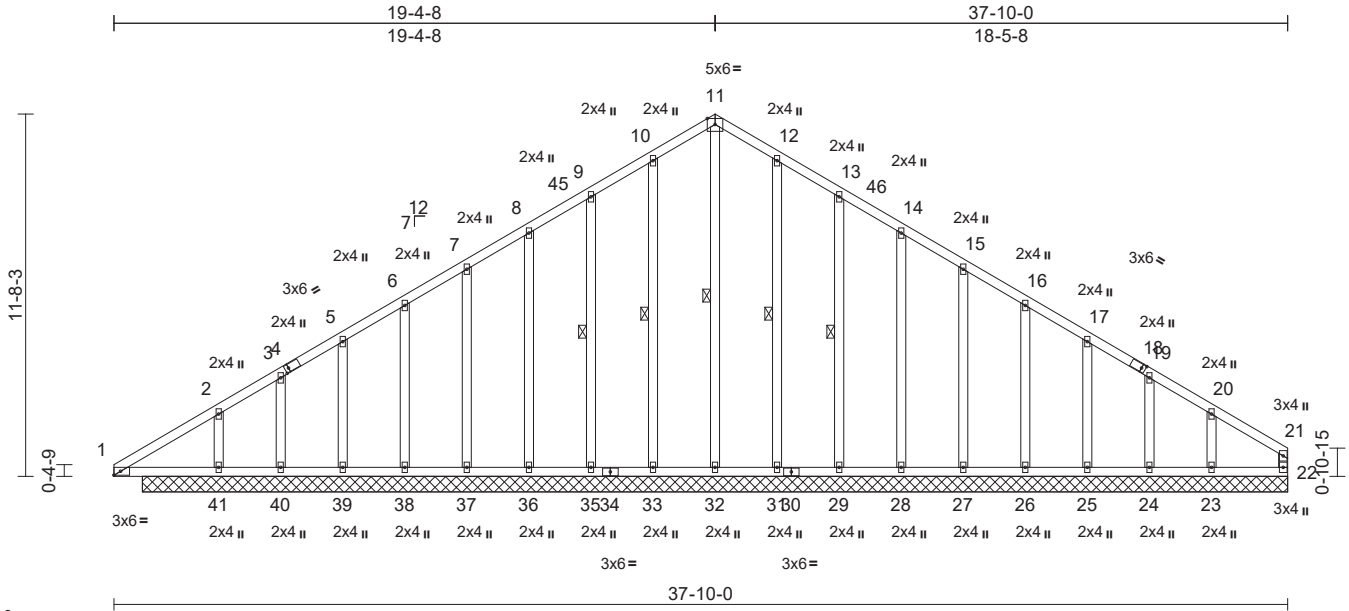

Scale = 1:74.3  
Plate Offsets (X, Y): [4:0-1-8,0-1-8], [18:0-1-8,0-1-8]

Loading	(psf)	Spacing	2-0-0	CSI	DEFL	in	(loc)	l/defl	L/d	PLATES	GRIP	
TCLL (roof)	20.0	Plate Grip DOL	1.00	TC	0.27	Vert(LL)	n/a	-	n/a	999	MT20	244/190
Snow (Ps/Pf)	13.2/20.0	Lumber DOL	1.15	BC	0.21	Vert(TL)	n/a	-	n/a	999		
TCDL	10.0	Rep Stress Incr	YES	WB	0.21	Horiz(TL)	-0.01	22	n/a	n/a		
BCLL	0.0*	Code	IRC2015/TPI2014	Matrix-MS								
BCDL	10.0											
											Weight: 279 lb	FT = 20%

LUMBER		Max Grav		
TOP CHORD	2x4 SP No.2	22=127 (LC 12), 23=321 (LC 30), 24=139 (LC 34), 25=174 (LC 30), 26=159 (LC 30), 27=162 (LC 30), 28=163 (LC 30), 29=193 (LC 23), 31=227 (LC 23), 32=358 (LC 31), 33=226 (LC 22), 35=185 (LC 22), 36=162 (LC 29), 37=163 (LC 29), 38=157 (LC 29), 39=191 (LC 2), 40=91 (LC 14), 41=369 (LC 2)		
BOT CHORD	2x4 SP No.2			
WEBS	2x4 SP No.3			
OTHERS	2x4 SP No.3			
BRACING				
TOP CHORD	Structural wood sheathing directly applied or 10-0-0 oc purlins, except end verticals.			
BOT CHORD	Rigid ceiling directly applied or 6-0-0 oc bracing.			
WEBS	1 Row at midpt	11-32, 10-33, 9-35, 12-31, 13-29		
REACTIONS	(size)	22=36-11-0, 23=36-11-0, 24=36-11-0, 25=36-11-0, 26=36-11-0, 27=36-11-0, 28=36-11-0, 29=36-11-0, 31=36-11-0, 32=36-11-0, 33=36-11-0, 35=36-11-0, 36=36-11-0, 37=36-11-0, 38=36-11-0, 39=36-11-0, 40=36-11-0, 41=36-11-0		
Max Horiz		41=226 (LC 15)		
Max Uplift		22=-165 (LC 15), 23=-99 (LC 17), 24=-13 (LC 17), 25=-38 (LC 17), 26=-32 (LC 17), 27=-33 (LC 17), 28=-32 (LC 17), 29=-38 (LC 17), 31=-23 (LC 17), 33=-19 (LC 16), 35=-40 (LC 16), 36=-32 (LC 16), 37=-33 (LC 16), 38=-36 (LC 16), 39=-22 (LC 16), 40=-78 (LC 16), 41=-9 (LC 17)		
FORCES	(lb) - Maximum Compression/Maximum Tension			
TOP CHORD		1-2=-48/231, 2-3=-18/178, 3-5=0/193, 5-6=0/192, 6-7=-16/201, 7-8=-48/222, 8-9=-80/243, 9-10=-113/272, 10-11=-143/303, 11-12=-143/303, 12-13=-113/288, 13-14=-80/276, 14-15=-48/268, 15-16=-51/260, 16-17=-70/254, 17-19=-93/268, 19-20=-113/267, 20-21=-155/320, 21-22=-87/136		
BOT CHORD		1-41=-166/72, 40-41=-244/140, 39-40=-244/140, 38-39=-244/140, 37-38=-244/140, 36-37=-244/140, 35-36=-244/140, 33-35=-244/140, 32-33=-244/140, 31-32=-244/140, 29-31=-244/140, 28-29=-244/140, 27-28=-244/140, 26-27=-244/140, 25-26=-244/140, 24-25=-244/140, 23-24=-244/140, 22-23=-244/140		
WEBS		11-32=-318/45, 10-33=-186/42, 9-35=-145/64, 8-36=-122/56, 7-37=-122/57, 6-38=-120/58, 5-39=-134/53, 3-40=-85/74, 2-41=-227/63, 12-31=-187/47, 13-29=-153/62, 14-28=-123/56, 15-27=-122/57, 16-26=-121/57, 17-25=-127/60, 19-24=-108/48, 20-23=-204/95		

- Unbalanced roof live loads have been considered for this design.
- Wind: ASCE 7-10; Vult=115mph (3-second gust) Vasd=91mph; TCDL=6.0psf; BCDL=6.0psf; h=30ft; Cat. II; Exp B; Enclosed; MWFRS (envelope) exterior zone and C-C Exterior (2) zone; cantilever left and right exposed; end vertical left and right exposed; C-C for members and forces & MWFRS for reactions shown; Lumber DOL=1.60 plate grip DOL=1.33
- Truss designed for wind loads in the plane of the truss only. For studs exposed to wind (normal to the face), see Standard Industry Gable End Details as applicable, or consult qualified building designer as per ANSI/TPI 1.
- TCLL: ASCE 7-10; Pr=20.0 psf (roof live load; Lumber DOL=1.15 Plate DOL=1.00); Pf=20.0 psf (flat roof snow); Ps=13.2 psf (roof snow; Lumber DOL=1.15 Plate DOL=1.00); Category II; Exp B; Fully Exp.; Ct=1.10; Unobstructed slippery surface
- Roof design snow load has been reduced to account for slope.
- Unbalanced snow loads have been considered for this design.



NOTES

October 16, 2023

Continued on page 2

**WARNING - Verify design parameters and READ NOTES ON THIS AND INCLUDED MITEK REFERENCE PAGE MII-7473 rev. 1/2/2023 BEFORE USE.**

Design valid for use only with MiTek® connectors. This design is based only upon parameters shown, and is for an individual building component, not a truss system. Before use, the building designer must verify the applicability of design parameters and properly incorporate this design into the overall building design. Bracing indicated is to prevent buckling of individual truss web and/or chord members only. Additional temporary and permanent bracing is always required for stability and to prevent collapse with possible personal injury and property damage. For general guidance regarding the fabrication, storage, delivery, erection and bracing of trusses and truss systems, see **ANSI/TPI1 Quality Criteria and DSB-22** available from Truss Plate Institute (www.tpinst.org) and **BCSI Building Component Safety Information** available from the Structural Building Component Association (www.sbcacomponents.com)



818 Soundside Road  
Edenton, NC 27932

Job ELV B CP 3CG	Truss A03G	Truss Type Common Supported Gable	Qty 1	Ply 1	Chesapeake Homes 628 Roof Job Reference (optional) I61390499
---------------------	---------------	--------------------------------------	----------	----------	--

Builders FirstSource (Apex, NC), Apex, NC - 27523,

Run: 8.63 S Aug 30 2023 Print: 8.630 S Aug 30 2023 MiTek Industries, Inc. Thu Oct 12 18:28:14  
ID:G9akxTit4GFRxLgAJ5Y3mKzIBU3-RfC?PsB70Hq3NSgPqnL8w3uITXbGKWrCDoi7J4zJC?f

Page: 2

- 7) Gable studs spaced at 2-0-0 oc.
- 8) This truss has been designed for a 10.0 psf bottom chord live load nonconcurrent with any other live loads.
- 9) \* This truss has been designed for a live load of 20.0psf on the bottom chord in all areas where a rectangle 3-06-00 tall by 2-00-00 wide will fit between the bottom chord and any other members.
- 10) All bearings are assumed to be SP No.2 crushing capacity of 565 psi.
- 11) Provide mechanical connection (by others) of truss to bearing plate capable of withstanding 165 lb uplift at joint 22, 19 lb uplift at joint 33, 40 lb uplift at joint 35, 32 lb uplift at joint 36, 33 lb uplift at joint 37, 36 lb uplift at joint 38, 22 lb uplift at joint 39, 78 lb uplift at joint 40, 9 lb uplift at joint 41, 23 lb uplift at joint 31, 38 lb uplift at joint 29, 32 lb uplift at joint 28, 33 lb uplift at joint 27, 32 lb uplift at joint 26, 38 lb uplift at joint 25, 13 lb uplift at joint 24 and 99 lb uplift at joint 23.
- 12) Non Standard bearing condition. Review required.
- 13) This truss is designed in accordance with the 2015 International Residential Code sections R502.11.1 and R802.10.2 and referenced standard ANSI/TPI 1.

**LOAD CASE(S)** Standard

**WARNING - Verify design parameters and READ NOTES ON THIS AND INCLUDED MITEK REFERENCE PAGE MII-7473 rev. 1/2/2023 BEFORE USE.**

Design valid for use only with MiTek® connectors. This design is based only upon parameters shown, and is for an individual building component, not a truss system. Before use, the building designer must verify the applicability of design parameters and properly incorporate this design into the overall building design. Bracing indicated is to prevent buckling of individual truss web and/or chord members only. Additional temporary and permanent bracing is always required for stability and to prevent collapse with possible personal injury and property damage. For general guidance regarding the fabrication, storage, delivery, erection and bracing of trusses and truss systems, see **ANSI/TPI1 Quality Criteria and DSB-22** available from Truss Plate Institute ([www.tpinst.org](http://www.tpinst.org)) and **BCSI Building Component Safety Information** available from the Structural Building Component Association ([www.sbcacomponents.com](http://www.sbcacomponents.com))



818 Soundside Road  
Edenton, NC 27932

Job ELV B CP 3CG	Truss A03H	Truss Type Common	Qty 7	Ply 1	Chesapeake Homes 628 Roof Job Reference (optional)	161390500
---------------------	---------------	----------------------	----------	----------	---	-----------

Builders FirstSource (Apex, NC), Apex, NC - 27523,

Run: 8.63 S Aug 30 2023 Print: 8.630 S Aug 30 2023 MiTek Industries, Inc. Thu Oct 12 18:28:14  
ID: jNLPutScT6pqliSQQ1DRE6ziBWz-RfC?PsB70Hq3NSgPqnL8w3uITxBGKwRcDoi7J4zJC7f

Page: 1

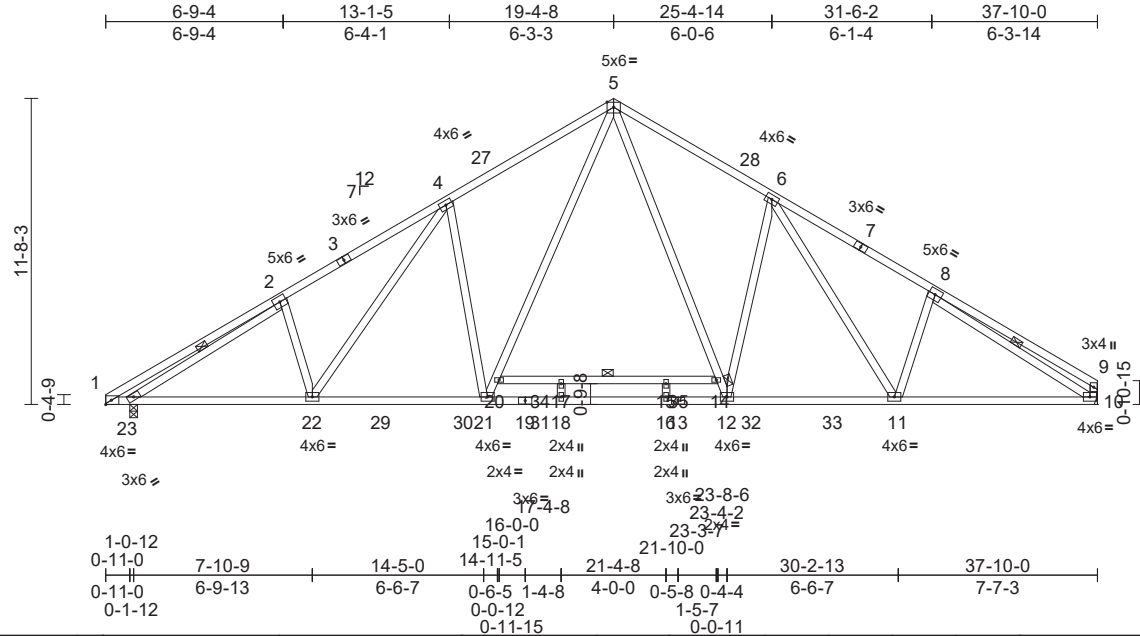

Loading	(psf)	Spacing	2-0-0	CSI	DEFL	in (loc)	l/defl	L/d	PLATES	GRIP		
TCLL (roof)	20.0	Plate Grip DOL	1.00	TC	0.81	Vert(LL)	-0.37	16-18	>999	240	MT20	244/190
Snow (Ps/Pf)	13.2/20.0	Lumber DOL	1.15	BC	0.89	Vert(CT)	-0.68	16-18	>654	180		
TCDL	10.0	Rep Stress Incr	YES	WB	0.71	Horz(CT)	0.10	10	n/a	n/a		
BCLL	0.0*	Code	IRC2015/TPI2014	Matrix-MS								
BCDL	10.0											
											Weight: 254 lb	FT = 20%

**LUMBER**  
TOP CHORD 2x4 SP No.2  
BOT CHORD 2x4 SP No.1 \*Except\* 14-20:2x4 SP No.2  
WEBS 2x4 SP No.3 \*Except\* 21-5:2x4 SP No.2

**BRACING**  
TOP CHORD Structural wood sheathing directly applied or 2-2-0 oc purlins, except end verticals.  
BOT CHORD Rigid ceiling directly applied or 10-0-0 oc bracing. Except: 6-0-0 oc bracing: 14-20  
WEBS 1 Row at midpt 2-23, 8-10

**REACTIONS** (size) 10= Mechanical, 23=0-3-8  
Max Horiz 23=226 (LC 15)  
Max Grav 10=1682 (LC 30), 23=1745 (LC 29)

**FORCES** (lb) - Maximum Compression/Maximum Tension  
TOP CHORD 1-2=-812/62, 2-4=-2575/151, 4-5=-2303/186, 5-6=-2225/179, 6-8=-2496/150, 8-9=-508/87, 9-10=-388/78  
BOT CHORD 1-23=-15/610, 22-23=-61/2333, 21-22=0/2092, 18-21=0/1557, 16-18=0/1557, 12-16=0/1557, 11-12=0/1939, 10-11=-17/2087, 17-20=-29/6, 15-17=-29/6, 14-15=-29/6  
WEBS 2-23=-1886/25, 8-10=-2116/7, 20-21=-116/1037, 5-20=-77/1134, 5-14=-64/1090, 12-14=-94/1004, 2-22=-217/165, 4-22=-106/365, 4-21=-554/230, 6-12=-535/219, 6-11=-98/351, 8-11=-195/171, 15-16=-105/0, 17-18=-68/0

- Wind: ASCE 7-10; Vult=115mph (3-second gust) Vasd=91mph; TCDL=6.0psf; BCDL=6.0psf; h=30ft; Cat. II; Exp B; Enclosed; MWFRS (envelope) exterior zone and C-C Exterior (2) zone; cantilever left and right exposed; end vertical left and right exposed; C-C for members and forces & MWFRS for reactions shown; Lumber DOL=1.60 plate grip DOL=1.33
- TCLL: ASCE 7-10; Pr=20.0 psf (roof live load: Lumber DOL=1.15 Plate DOL=1.00); Pf=20.0 psf (flat roof snow); Ps=13.2 psf (roof snow: Lumber DOL=1.15 Plate DOL=1.00); Category II; Exp B; Fully Exp.; Ct=1.10; Unobstructed slippery surface
- Roof design snow load has been reduced to account for slope.
- Unbalanced snow loads have been considered for this design.
- This truss has been designed for a 10.0 psf bottom chord live load nonconcurrent with any other live loads.
- \* This truss has been designed for a live load of 20.0psf on the bottom chord in all areas where a rectangle 3-06-00 tall by 2-00-00 wide will fit between the bottom chord and any other members, with BCDL = 10.0psf.
- Bearings are assumed to be: Joint 23 SP No.1 crushing capacity of 565 psi.
- Refer to girder(s) for truss to truss connections.
- This truss is designed in accordance with the 2015 International Residential Code sections R502.11.1 and R802.10.2 and referenced standard ANSI/TPI 1.

**LOAD CASE(S)** Standard

**NOTES**

- Unbalanced roof live loads have been considered for this design.



October 16, 2023

**WARNING - Verify design parameters and READ NOTES ON THIS AND INCLUDED MITEK REFERENCE PAGE MII-7473 rev. 1/2/2023 BEFORE USE.**

Design valid for use only with MiTek® connectors. This design is based only upon parameters shown, and is for an individual building component, not a truss system. Before use, the building designer must verify the applicability of design parameters and properly incorporate this design into the overall building design. Bracing indicated is to prevent buckling of individual truss web and/or chord members only. Additional temporary and permanent bracing is always required for stability and to prevent collapse with possible personal injury and property damage. For general guidance regarding the fabrication, storage, delivery, erection and bracing of trusses and truss systems, see **ANSI/TPI1 Quality Criteria and DSB-22** available from Truss Plate Institute (www.tpinst.org) and **BCSI Building Component Safety Information** available from the Structural Building Component Association (www.sbccomponents.com)



818 Soundside Road  
Edenton, NC 27932



Job ELV B CP 3CG	Truss B01GR	Truss Type Common Girder	Qty 1	Ply 3	Chesapeake Homes 628 Roof Job Reference (optional)	I61390501
---------------------	----------------	-----------------------------	----------	----------	---	-----------

Builders FirstSource (Apex, NC), Apex, NC - 27523,

Run: 8.63 S Aug 30 2023 Print: 8.630 S Aug 30 2023 MiTek Industries, Inc. Thu Oct 12 18:28:15  
ID:0qSBijUGKjQ1vAirZaJCRzIBJfRfC?PsB70Hq3NSgPqnL8w3uITXbGKWRCDoi7J4zJC?f

Page: 1

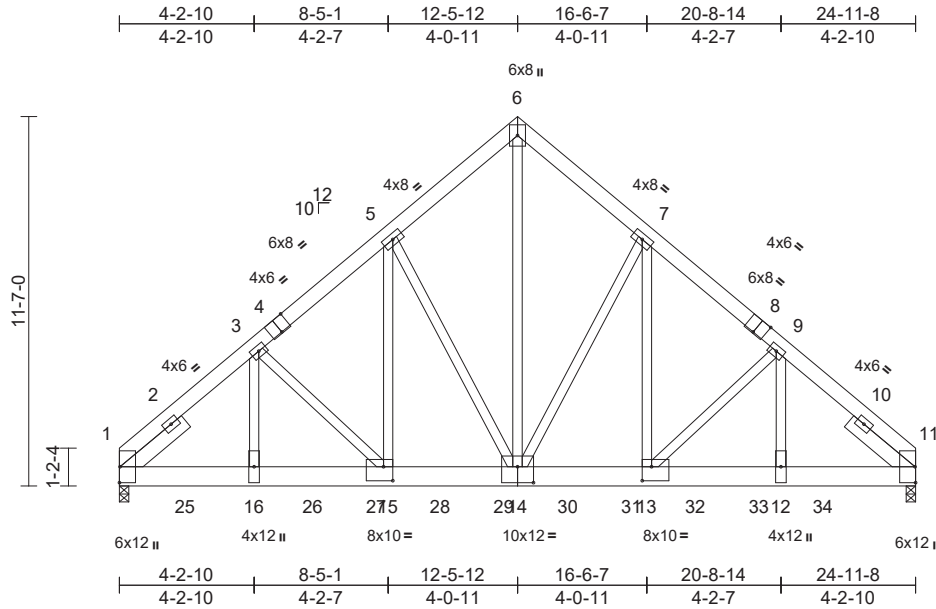

Scale = 1:72.2  
Plate Offsets (X, Y): [4:0-4-0,Edge], [8:0-4-0,Edge], [13:0-3-8,0-5-4], [14:0-6-0,0-6-0], [15:0-3-8,0-5-4]

Loading	(psf)	Spacing	2-0-0	CSI	DEFL	in	(loc)	l/defl	L/d	PLATES	GRIP	
TCLL (roof)	20.0	Plate Grip DOL	1.00	TC	0.64	Vert(LL)	-0.09	15-16	>999	240	MT20	244/190
Snow (Ps/Pf)	10.1/20.0	Lumber DOL	1.15	BC	0.36	Vert(CT)	-0.19	15-16	>999	180		
TCDL	10.0	Rep Stress Incr	NO	WB	0.79	Horz(CT)	0.05	11	n/a	n/a		
BCLL	0.0*	Code	IRC2015/TPI2014	Matrix-MS								
BCDL	10.0											
											Weight: 761 lb	FT = 20%

**LUMBER**  
TOP CHORD 2x6 SP No.2  
BOT CHORD 2x8 SP DSS  
WEBS 2x4 SP No.3 \*Except\* 14-6:2x4 SP No.2  
SLIDER Left 2x6 SP DSS -- 2-6-0, Right 2x6 SP DSS -- 2-6-0

**BRACING**  
TOP CHORD Structural wood sheathing directly applied or 6-0-0 oc purlins.  
BOT CHORD Rigid ceiling directly applied or 10-0-0 oc bracing.

**REACTIONS** (size) 1=0-3-8, 11=0-3-8, (req. 0-3-9)  
Max Horiz 1=-199 (LC 6)  
Max Grav 1=10051 (LC 21), 11=10637 (LC 22)

**FORCES** (lb) - Maximum Compression/Maximum Tension  
TOP CHORD 1-3=-11818/0, 3-5=-10347/0, 5-6=-8167/0, 6-7=-8166/0, 7-9=-10177/0, 9-11=-11442/0  
BOT CHORD 1-16=0/8779, 15-16=0/8779, 13-15=0/8077, 12-13=0/8387, 11-12=0/8387  
WEBS 3-16=0/2044, 3-15=-982/0, 5-15=0/4388, 5-14=-3720/0, 6-14=0/10042, 7-14=-3426/0, 7-13=0/4033, 9-13=-871/485, 9-12=-340/1809

**NOTES**  
1) 3-ply truss to be connected together with 10d (0.131"x3") nails as follows:  
Top chords connected as follows: 2x6 - 2 rows staggered at 0-9-0 oc.  
Bottom chords connected as follows: 2x8 - 2 rows staggered at 0-4-0 oc.  
Web connected as follows: 2x4 - 1 row at 0-9-0 oc, Except member 3-16 2x4 - 2 rows staggered at 0-6-0 oc.

- All loads are considered equally applied to all plies, except if noted as front (F) or back (B) face in the LOAD CASE(S) section. Ply to ply connections have been provided to distribute only loads noted as (F) or (B), unless otherwise indicated.
- Unbalanced roof live loads have been considered for this design.
- Wind: ASCE 7-10; Vult=115mph (3-second gust) Vasd=91mph; TCDL=6.0psf; BCDL=6.0psf; h=30ft; Cat. II; Exp B; Enclosed; MWFRS (envelope) exterior zone; cantilever left and right exposed; end vertical left and right exposed; Lumber DOL=1.60 plate grip DOL=1.33
- TCLL: ASCE 7-10; Pr=20.0 psf (roof live load: Lumber DOL=1.15 Plate DOL=1.00); Pf=20.0 psf (flat roof snow); Ps=10.1 psf (roof snow: Lumber DOL=1.15 Plate DOL=1.00); Category II; Exp B; Fully Exp.; Ct=1.10; Unobstructed slippery surface
- Roof design snow load has been reduced to account for slope.
- This truss has been designed for a 10.0 psf bottom chord live load nonconcurrent with any other live loads.
- \* This truss has been designed for a live load of 20.0psf on the bottom chord in all areas where a rectangle 3-06-00 tall by 2-00-00 wide will fit between the bottom chord and any other members.
- WARNING: Required bearing size at joint(s) 11 greater than input bearing size.
- All bearings are assumed to be SP DSS crushing capacity of 660 psi.
- This truss is designed in accordance with the 2015 International Residential Code sections R502.11.1 and R802.10.2 and referenced standard ANSI/TPI 1.

- Hanger(s) or other connection device(s) shall be provided sufficient to support concentrated load(s) 1456 lb down and 44 lb up at 2-0-12, 1662 lb down at 4-0-12, 1662 lb down at 6-0-12, 1662 lb down at 8-0-12, 1662 lb down at 10-0-12, 1662 lb down at 12-0-12, 1662 lb down at 14-0-12, 1662 lb down at 16-0-12, 1456 lb down and 44 lb up at 18-0-12, 1456 lb down and 44 lb up at 20-0-12, and 1456 lb down and 44 lb up at 22-0-12, and 1459 lb down and 42 lb up at 24-0-12 on bottom chord. The design/selection of such connection device(s) is the responsibility of others.

**LOAD CASE(S)** Standard  
1) Dead + Snow (balanced): Lumber Increase=1.15, Plate Increase=1.00  
Uniform Loads (lb/ft)  
Vert: 1-6=-40, 6-11=-40, 17-21=-20  
Concentrated Loads (lb)  
Vert: 16=-1307 (B), 23=-1222 (B), 25=-1219 (B), 26=-1307 (B), 27=-1307 (B), 28=-1307 (B), 29=-1307 (B), 30=-1307 (B), 31=-1307 (B), 32=-1219 (B), 33=-1219 (B), 34=-1219 (B)



October 16, 2023

**WARNING - Verify design parameters and READ NOTES ON THIS AND INCLUDED MITEK REFERENCE PAGE MII-7473 rev. 1/2/2023 BEFORE USE.**

Design valid for use only with MiTek® connectors. This design is based only upon parameters shown, and is for an individual building component, not a truss system. Before use, the building designer must verify the applicability of design parameters and properly incorporate this design into the overall building design. Bracing indicated is to prevent buckling of individual truss web and/or chord members only. Additional temporary and permanent bracing is always required for stability and to prevent collapse with possible personal injury and property damage. For general guidance regarding the fabrication, storage, delivery, erection and bracing of trusses and truss systems, see **ANSI/TPI1 Quality Criteria and DSB-22** available from Truss Plate Institute (www.tpinst.org) and **BCSI Building Component Safety Information** available from the Structural Building Component Association (www.sbcacomponents.com)



818 Soundside Road  
Edenton, NC 27932

Job ELV B CP 3CG	Truss B02	Truss Type Common	Qty 1	Ply 1	Chesapeake Homes 628 Roof Job Reference (optional)	I61390502
---------------------	--------------	----------------------	----------	----------	---	-----------

Builders FirstSource (Apex, NC), Apex, NC - 27523,

Run: 8.63 S Aug 30 2023 Print: 8.630 S Aug 30 2023 MiTek Industries, Inc. Thu Oct 12 18:28:16  
ID:c5Td3hHYNcYRSqJ3ffsTmlzIBPR-RfC?PsB70Hq3NSgPqnL8w3ulTXbGKWrCDoi7J4zJC?f

Page: 1

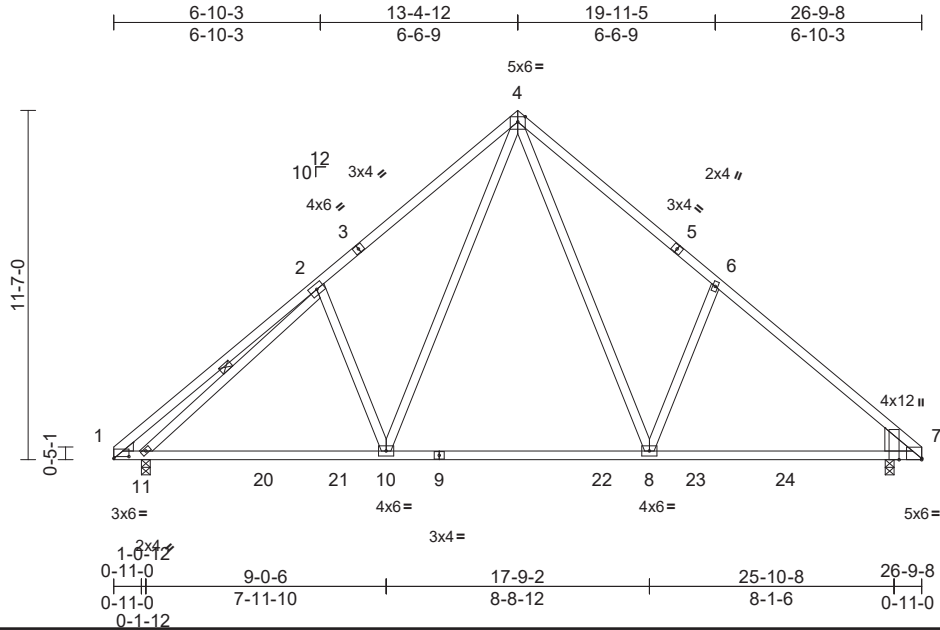

Scale = 1:76.4

Plate Offsets (X, Y): [1:0-6-0,0-0-12], [7:Edge,0-0-8], [7:0-0-8,Edge]

Loading	(psf)	Spacing	2-0-0	CSI	DEFL	in	(loc)	l/defl	L/d	PLATES	GRIP	
TCLL (roof)	20.0	Plate Grip DOL	1.00	TC	0.71	Vert(LL)	-0.24	8-10	>999	240	MT20	244/190
Snow (Ps/Pf)	10.1/20.0	Lumber DOL	1.15	BC	0.90	Vert(CT)	-0.40	8-10	>782	180		
TCDL	10.0	Rep Stress Incr	YES	WB	0.36	Horz(CT)	0.04	7	n/a	n/a		
BCLL	0.0*	Code	IRC2015/TPI2014	Matrix-MS								
BCDL	10.0											
											Weight: 161 lb	FT = 20%

**LUMBER**  
TOP CHORD 2x4 SP No.2  
BOT CHORD 2x4 SP No.2  
WEBS 2x4 SP No.3  
WEDGE Left: 2x4 SP No.3  
Right: 2x10 SP DSS

**BRACING**  
TOP CHORD Structural wood sheathing directly applied or 3-11-2 oc purlins.  
BOT CHORD Rigid ceiling directly applied or 10-0-0 oc bracing.  
WEBS 1 Row at midpt 2-11

**REACTIONS** (size) 7=0-3-8, 11=0-3-8  
Max Horiz 11=216 (LC 10)  
Max Uplift 7=-10 (LC 15), 11=-10 (LC 14)  
Max Grav 7=1135 (LC 26), 11=1112 (LC 25)

**FORCES** (lb) - Maximum Compression/Maximum Tension  
TOP CHORD 1-2=-451/104, 2-4=-1173/233,  
4-6=-1150/236, 6-7=-1246/122  
BOT CHORD 1-11=-50/248, 10-11=-81/1013, 8-10=0/675,  
7-8=-29/885  
WEBS 4-8=-126/598, 6-8=-298/226, 4-10=-118/629,  
2-10=-289/233, 2-11=-926/41

- TCLL: ASCE 7-10; Pr=20.0 psf (roof live load: Lumber DOL=1.15 Plate DOL=1.00); Pf=20.0 psf (flat roof snow); Ps=10.1 psf (roof snow: Lumber DOL=1.15 Plate DOL=1.00); Category II; Exp B; Fully Exp.; Ct=1.10; Unobstructed slippery surface
- Roof design snow load has been reduced to account for slope.
- This truss has been designed for a 10.0 psf bottom chord live load nonconcurrent with any other live loads.
- \* This truss has been designed for a live load of 20.0psf on the bottom chord in all areas where a rectangle 3-06-00 tall by 2-00-00 wide will fit between the bottom chord and any other members, with BCDL = 10.0psf.
- All bearings are assumed to be SP No.2 crushing capacity of 565 psi.
- Provide mechanical connection (by others) of truss to bearing plate capable of withstanding 10 lb uplift at joint 7 and 10 lb uplift at joint 11.
- This truss is designed in accordance with the 2015 International Residential Code sections R502.11.1 and R802.10.2 and referenced standard ANSI/TPI 1.

**LOAD CASE(S)** Standard

**NOTES**

- Unbalanced roof live loads have been considered for this design.
- Wind: ASCE 7-10; Vult=115mph (3-second gust) Vasd=91mph; TCDL=6.0psf; BCDL=6.0psf; h=30ft; Cat. II; Exp B; Enclosed; MWFRS (envelope) exterior zone and C-C Exterior (2) zone; cantilever left and right exposed; end vertical left and right exposed; C-C for members and forces & MWFRS for reactions shown; Lumber DOL=1.60 plate grip DOL=1.33



October 16, 2023

**WARNING - Verify design parameters and READ NOTES ON THIS AND INCLUDED MITEK REFERENCE PAGE MII-7473 rev. 1/2/2023 BEFORE USE.**

Design valid for use only with MiTek® connectors. This design is based only upon parameters shown, and is for an individual building component, not a truss system. Before use, the building designer must verify the applicability of design parameters and properly incorporate this design into the overall building design. Bracing indicated is to prevent buckling of individual truss web and/or chord members only. Additional temporary and permanent bracing is always required for stability and to prevent collapse with possible personal injury and property damage. For general guidance regarding the fabrication, storage, delivery, erection and bracing of trusses and truss systems, see **ANSI/TPI1 Quality Criteria and DSB-22** available from Truss Plate Institute (www.tpinst.org) and **BCSI Building Component Safety Information** available from the Structural Building Component Association (www.sbcacomponents.com)



818 Soundside Road  
Edenton, NC 27932

Job ELV B CP 3CG	Truss B02G	Truss Type Common Supported Gable	Qty 1	Ply 1	Chesapeake Homes 628 Roof Job Reference (optional)	161390503
---------------------	---------------	--------------------------------------	----------	----------	---	-----------

Builders FirstSource (Apex, NC), Apex, NC - 27523,

Run: 8.63 S Aug 30 2023 Print: 8.630 S Aug 30 2023 MiTek Industries, Inc. Thu Oct 12 18:28:16  
ID:j3iheV1NJluQRbC1wL\_YQKzIBPm-RfC?PsB70Hq3NSgPqnL8w3uITxBGKWrCdoiJ4zJCf

Page: 1

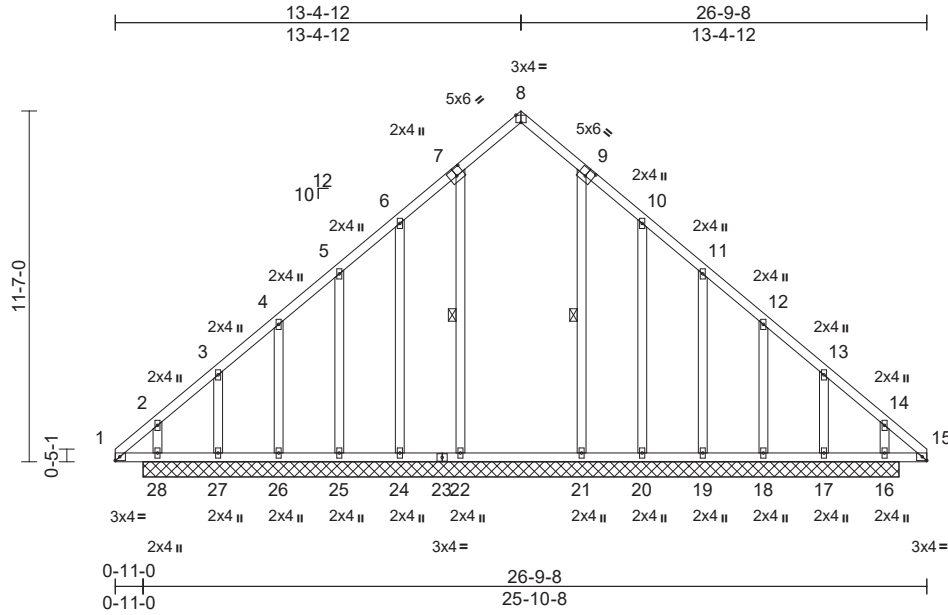

Scale = 1:76.1

Plate Offsets (X, Y): [7:0-3-0,0-3-0], [8:0-2-0,Edge], [9:0-3-0,0-3-0], [15:0-1-13,Edge]

Loading	(psf)	Spacing	2-0-0	CSI	DEFL	in	(loc)	l/defl	L/d	PLATES	GRIP	
TCLL (roof)	20.0	Plate Grip DOL	1.00	TC	0.18	Vert(LL)	n/a	-	n/a	999	MT20	244/190
Snow (Ps/Pf)	10.1/20.0	Lumber DOL	1.15	BC	0.30	Vert(TL)	n/a	-	n/a	999		
TCDL	10.0	Rep Stress Incr	YES	WB	0.17	Horiz(TL)	0.01	16	n/a	n/a		
BCLL	0.0*	Code	IRC2015/TPI2014	Matrix-MS								
BCDL	10.0											
											Weight: 185 lb	FT = 20%

**LUMBER**  
TOP CHORD 2x4 SP No.2  
BOT CHORD 2x4 SP No.2  
OTHERS 2x4 SP No.3

**BRACING**  
TOP CHORD Structural wood sheathing directly applied or 6-0-0 oc purlins.  
BOT CHORD Rigid ceiling directly applied or 10-0-0 oc bracing.  
WEBS 1 Row at midpt 7-22, 9-21

**REACTIONS** (size)  
16=24-11-8, 17=24-11-8,  
18=24-11-8, 19=24-11-8,  
20=24-11-8, 21=24-11-8,  
22=24-11-8, 24=24-11-8,  
25=24-11-8, 26=24-11-8,  
27=24-11-8, 28=24-11-8  
Max Horiz 28=-216 (LC 10)  
Max Uplift 16=-30 (LC 11), 17=-265 (LC 15),  
18=-2 (LC 15), 19=-61 (LC 15),  
20=-99 (LC 15), 24=-97 (LC 14),  
25=-61 (LC 14), 26=-1 (LC 14),  
27=-269 (LC 14), 28=-39 (LC 10)  
Max Grav 16=375 (LC 28), 17=196 (LC 13),  
18=179 (LC 2), 19=184 (LC 26),  
20=120 (LC 30), 21=322 (LC 26),  
22=327 (LC 25), 24=120 (LC 29),  
25=184 (LC 25), 26=179 (LC 2),  
27=201 (LC 12), 28=380 (LC 27)

**FORCES** (lb) - Maximum Compression/Maximum Tension  
TOP CHORD 1-2=-234/151, 2-3=-277/152, 3-4=-153/92,  
4-5=-135/74, 5-6=-121/54, 6-8=-123/119,  
8-10=-123/113, 10-11=-116/48,  
11-12=-130/67, 12-13=-149/85,  
13-14=-272/152, 14-15=-231/151

**BOT CHORD** 1-28=-137/231, 27-28=-137/229,  
26-27=-137/229, 25-26=-137/229,  
24-25=-137/229, 22-24=-137/229,  
21-22=-138/227, 20-21=-137/228,  
19-20=-137/228, 18-19=-137/228,  
17-18=-137/228, 16-17=-137/228,  
15-16=-137/228  
**WEBS** 7-22=-178/5, 6-24=-142/118, 5-25=-134/78,  
4-26=-127/58, 3-27=-163/169, 2-28=-169/7,  
9-21=-177/0, 10-20=-142/118,  
11-19=-133/78, 12-18=-127/58,  
13-17=-163/168, 14-16=-167/3

**NOTES**  
1) Unbalanced roof live loads have been considered for this design.  
2) Wind: ASCE 7-10; Vult=115mph (3-second gust) Vasd=91mph; TCDL=6.0psf; BCDL=6.0psf; h=30ft; Cat. II; Exp B; Enclosed; MWFRS (envelope) exterior zone and C-C Exterior (2) zone; cantilever left and right exposed; end vertical left and right exposed; C-C for members and forces & MWFRS for reactions shown; Lumber DOL=1.60 plate grip DOL=1.33  
3) Truss designed for wind loads in the plane of the truss only. For studs exposed to wind (normal to the face), see Standard Industry Gable End Details as applicable, or consult qualified building designer as per ANSI/TPI 1.  
4) TCLL: ASCE 7-10; Pr=20.0 psf (roof live load: Lumber DOL=1.15 Plate DOL=1.00); Pf=20.0 psf (flat roof snow); Ps=10.1 psf (roof snow: Lumber DOL=1.15 Plate DOL=1.00); Category II; Exp B; Fully Exp.; Ct=1.10; Unobstructed slippery surface  
5) Roof design snow load has been reduced to account for slope.  
6) Gable studs spaced at 2-0-0 oc.  
7) This truss has been designed for a 10.0 psf bottom chord live load nonconcurrent with any other live loads.

8) \* This truss has been designed for a live load of 20.0psf on the bottom chord in all areas where a rectangle 3-06-00 tall by 2-00-00 wide will fit between the bottom chord and any other members, with BCDL = 10.0psf.  
9) All bearings are assumed to be SP No.2 crushing capacity of 565 psi.  
10) Provide mechanical connection (by others) of truss to bearing plate capable of withstanding 97 lb uplift at joint 24, 61 lb uplift at joint 25, 1 lb uplift at joint 26, 269 lb uplift at joint 27, 39 lb uplift at joint 28, 99 lb uplift at joint 20, 61 lb uplift at joint 19, 2 lb uplift at joint 18, 265 lb uplift at joint 17 and 30 lb uplift at joint 16.  
11) Non Standard bearing condition. Review required.  
12) This truss is designed in accordance with the 2015 International Residential Code sections R502.11.1 and R802.10.2 and referenced standard ANSI/TPI 1.  
**LOAD CASE(S)** Standard



October 16, 2023

**WARNING - Verify design parameters and READ NOTES ON THIS AND INCLUDED MITEK REFERENCE PAGE MII-7473 rev. 1/2/2023 BEFORE USE.**

Design valid for use only with MiTek® connectors. This design is based only upon parameters shown, and is for an individual building component, not a truss system. Before use, the building designer must verify the applicability of design parameters and properly incorporate this design into the overall building design. Bracing indicated is to prevent buckling of individual truss web and/or chord members only. Additional temporary and permanent bracing is always required for stability and to prevent collapse with possible personal injury and property damage. For general guidance regarding the fabrication, storage, delivery, erection and bracing of trusses and truss systems, see **ANSI/TPI Quality Criteria and DSB-22** available from Truss Plate Institute (www.tpinst.org) and **BCSI Building Component Safety Information** available from the Structural Building Component Association (www.sbcacomponents.com)



818 Soundside Road  
Edenton, NC 27932

Job ELV B CP 3CG	Truss CP01	Truss Type Common	Qty 5	Ply 1	Chesapeake Homes 628 Roof Job Reference (optional)	161390504
---------------------	---------------	----------------------	----------	----------	---	-----------

Builders FirstSource (Apex, NC), Apex, NC - 27523,

Run: 8.63 S Aug 30 2023 Print: 8.630 S Aug 30 2023 MiTek Industries, Inc. Thu Oct 12 18:28:16  
ID: YJ08J4HIsFBO4A9F2T\_s5gzd29o-RfC?PsB70Hq3NSgPqnL8w3uITXbGKWrCDoi7J4zJC?f

Page: 1

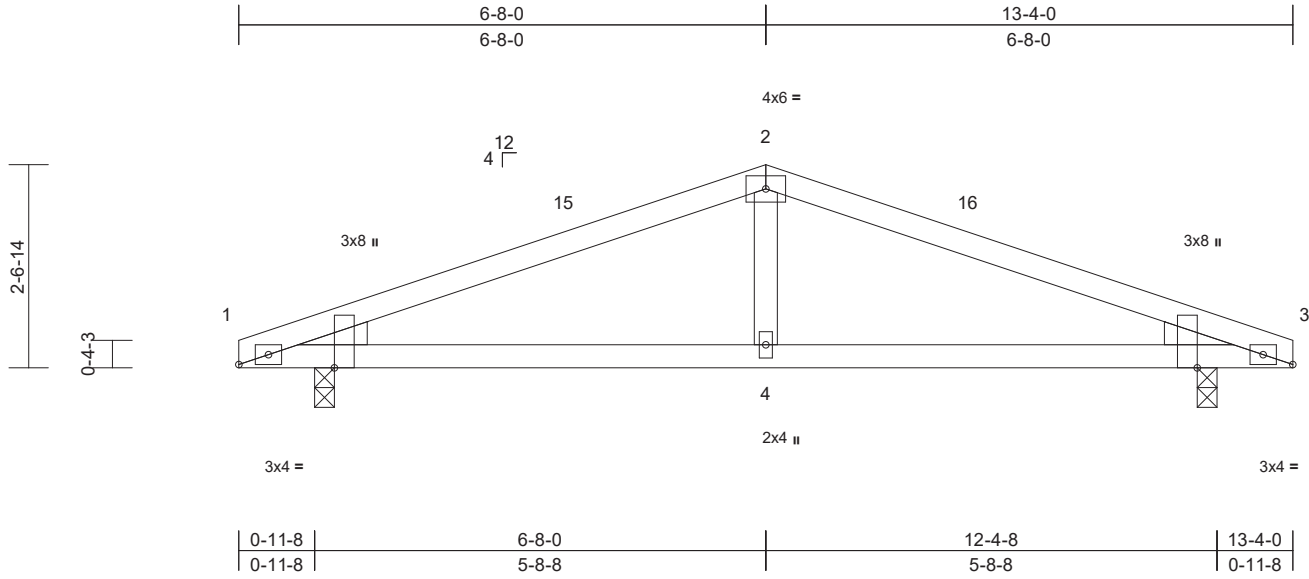

Scale = 1:29.1

Plate Offsets (X, Y): [1:0-2-8,Edge], [1:0-0-8,Edge], [3:0-2-8,Edge], [3:0-0-8,Edge]

Loading	(psf)	Spacing	2-0-0	CSI	DEFL	in	(loc)	l/defl	L/d	PLATES	GRIP	
TCLL (roof)	20.0	Plate Grip DOL	1.00	TC	0.33	Vert(LL)	-0.03	4-14	>999	240	MT20	244/190
Snow (Ps/Pf)	17.2/20.0	Lumber DOL	1.15	BC	0.28	Vert(CT)	-0.05	4-14	>999	180		
TCDL	10.0	Rep Stress Incr	YES	WB	0.08	Horz(CT)	0.01	3	n/a	n/a		
BCLL	0.0*	Code	IRC2015/TPI2014	Matrix-MS								
BCDL	10.0										Weight: 47 lb	FT = 20%

- LUMBER**
- TOP CHORD 2x4 SP No.2
  - BOT CHORD 2x4 SP No.2
  - WEBS 2x4 SP No.3
  - WEDGE Left: 2x4 SP No.3  
Right: 2x4 SP No.3
- BRACING**
- TOP CHORD Structural wood sheathing directly applied or 6-0-0 oc purlins.
  - BOT CHORD Rigid ceiling directly applied or 10-0-0 oc bracing.
- REACTIONS** (size) 1=0-3-0, 3=0-3-0  
 Max Horiz 1=29 (LC 16)  
 Max Uplift 1=-26 (LC 12), 3=-26 (LC 13)  
 Max Grav 1=533 (LC 2), 3=533 (LC 2)
- FORCES** (lb) - Maximum Compression/Maximum Tension  
 TOP CHORD 1-2=-700/124, 2-3=-700/124  
 BOT CHORD 1-4=-58/617, 3-4=-58/617  
 WEBS 2-4=0/215

- Unbalanced snow loads have been considered for this design.
  - This truss has been designed for a 10.0 psf bottom chord live load nonconcurrent with any other live loads.
  - \* This truss has been designed for a live load of 20.0psf on the bottom chord in all areas where a rectangle 3-06-00 tall by 2-00-00 wide will fit between the bottom chord and any other members.
  - All bearings are assumed to be SP No.2 crushing capacity of 565 psi.
  - Provide mechanical connection (by others) of truss to bearing plate capable of withstanding 26 lb uplift at joint 1 and 26 lb uplift at joint 3.
  - This truss is designed in accordance with the 2015 International Residential Code sections R502.11.1 and R802.10.2 and referenced standard ANSI/TPI 1.
- LOAD CASE(S)** Standard

- NOTES**
- Unbalanced roof live loads have been considered for this design.
  - Wind: ASCE 7-10; Vult=115mph (3-second gust) Vasd=91mph; TCDL=6.0psf; BCDL=6.0psf; h=30ft; Cat. II; Exp B; Enclosed; MWFRS (envelope) exterior zone and C-C Exterior (2) zone; cantilever left and right exposed; end vertical left and right exposed; C-C for members and forces & MWFRS for reactions shown; Lumber DOL=1.60 plate grip DOL=1.33
  - TCLL: ASCE 7-10; Pr=20.0 psf (roof live load: Lumber DOL=1.15 Plate DOL=1.00); Pf=20.0 psf (flat roof snow); Ps=17.2 psf (roof snow: Lumber DOL=1.15 Plate DOL=1.00); Category II; Exp B; Fully Exp.; Ct=1.10; Unobstructed slippery surface
  - Roof design snow load has been reduced to account for slope.



October 16, 2023

Job ELV B CP 3CG	Truss CP01G	Truss Type Common Supported Gable	Qty 1	Ply 1	Chesapeake Homes 628 Roof Job Reference (optional)	161390505
---------------------	----------------	--------------------------------------	----------	----------	---	-----------

Builders FirstSource (Apex, NC), Apex, NC - 27523,

Run: 8.63 S Aug 30 2023 Print: 8.630 S Aug 30 2023 MiTek Industries, Inc. Thu Oct 12 18:28:17  
ID:Q4Gf9RKwUHQyOT0HJ2oGWzd29k-RfC?PsB70Hq3NSgPqnL8w3ulTXbGKwRCDoi7J4zJC?f

Page: 1

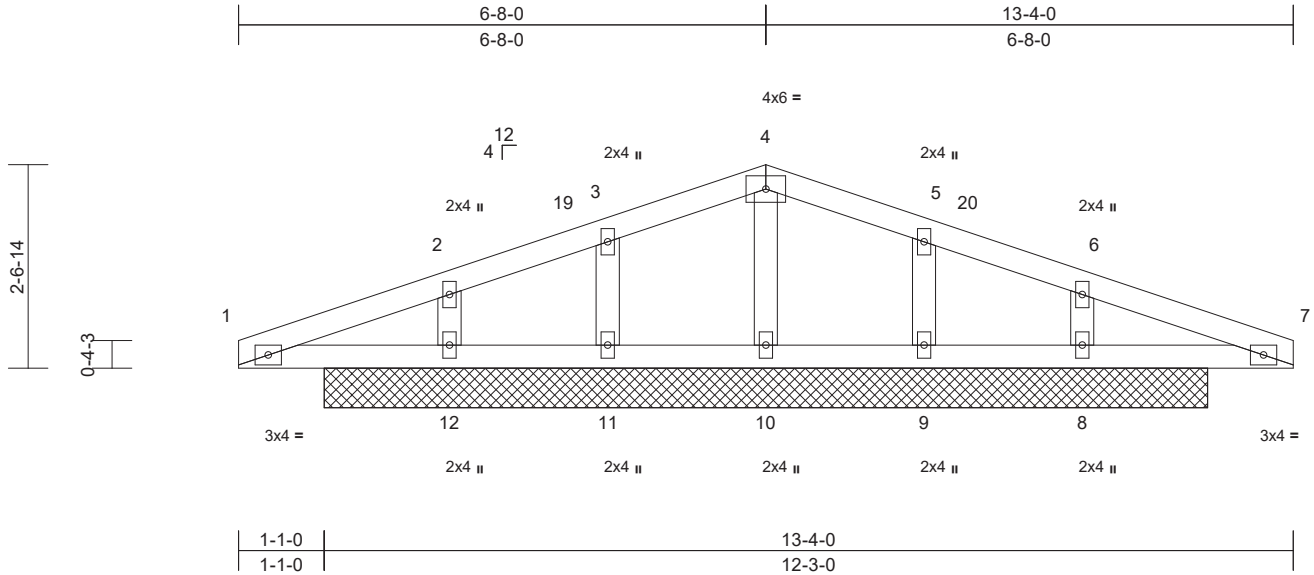

Scale = 1:29.1

Loading	(psf)	Spacing	2-0-0	CSI	DEFL	in	(loc)	l/defl	L/d	PLATES	GRIP	
TCLL (roof)	20.0	Plate Grip DOL	1.00	TC	0.19	Vert(LL)	n/a	-	n/a	999	MT20	244/190
Snow (Ps/Pf)	17.2/20.0	Lumber DOL	1.15	BC	0.15	Vert(TL)	n/a	-	n/a	999		
TCDL	10.0	Rep Stress Incr	YES	WB	0.06	Horiz(TL)	0.00	8	n/a	n/a		
BCLL	0.0*	Code	IRC2015/TPI2014	Matrix-MS								
BCDL	10.0											
										Weight: 50 lb	FT = 20%	

**LUMBER**

TOP CHORD 2x4 SP No.2  
BOT CHORD 2x4 SP No.2  
OTHERS 2x4 SP No.3

**BRACING**

TOP CHORD Structural wood sheathing directly applied or 10-0-0 oc purlins.  
BOT CHORD Rigid ceiling directly applied or 6-0-0 oc bracing.

**REACTIONS**

(size) 8=11-2-0, 9=11-2-0, 10=11-2-0,  
11=11-2-0, 12=11-2-0  
Max Horiz 12=29 (LC 16)  
Max Uplift 8=-34 (LC 17), 9=-15 (LC 13),  
11=-16 (LC 12), 12=-33 (LC 16)  
Max Grav 8=306 (LC 34), 9=122 (LC 2),  
10=309 (LC 2), 11=122 (LC 2),  
12=306 (LC 33)

**FORCES**

(lb) - Maximum Compression/Maximum Tension

TOP CHORD 1-2=-32/253, 2-3=-5/239, 3-4=0/243,  
4-5=0/243, 5-6=-5/239, 6-7=-32/253  
BOT CHORD 1-12=-213/46, 11-12=-213/46,  
10-11=-213/46, 9-10=-213/46, 8-9=-213/46,  
7-8=-213/46  
WEBS 4-10=-256/30, 3-11=-108/56, 2-12=-187/63,  
5-9=-108/56, 6-8=-187/63

**NOTES**

- Unbalanced roof live loads have been considered for this design.
- Wind: ASCE 7-10; Vult=115mph (3-second gust) Vasd=91mph; TCDL=6.0psf; BCDL=6.0psf; h=30ft; Cat. II; Exp B; Enclosed; MWFRS (envelope) exterior zone and C-C Exterior (2) zone; cantilever left and right exposed; end vertical left and right exposed; C-C for members and forces & MWFRS for reactions shown; Lumber DOL=1.60 plate grip DOL=1.33

- Truss designed for wind loads in the plane of the truss only. For studs exposed to wind (normal to the face), see Standard Industry Gable End Details as applicable, or consult qualified building designer as per ANSI/TPI 1.
- TCLL: ASCE 7-10; Pr=20.0 psf (roof live load: Lumber DOL=1.15 Plate DOL=1.00); Pf=20.0 psf (flat roof snow); Ps=17.2 psf (roof snow: Lumber DOL=1.15 Plate DOL=1.00); Category II; Exp B; Fully Exp.; Ct=1.10; Unobstructed slippery surface
- Roof design snow load has been reduced to account for slope.
- Unbalanced snow loads have been considered for this design.
- Gable studs spaced at 2-0-0 oc.
- This truss has been designed for a 10.0 psf bottom chord live load nonconcurrent with any other live loads.
- \* This truss has been designed for a live load of 20.0psf on the bottom chord in all areas where a rectangle 3-06-00 tall by 2-00-00 wide will fit between the bottom chord and any other members.
- All bearings are assumed to be SP No.2 crushing capacity of 565 psi.
- Provide mechanical connection (by others) of truss to bearing plate capable of withstanding 16 lb uplift at joint 11, 33 lb uplift at joint 12, 15 lb uplift at joint 9 and 34 lb uplift at joint 8.
- Non Standard bearing condition. Review required.
- This truss is designed in accordance with the 2015 International Residential Code sections R502.11.1 and R802.10.2 and referenced standard ANSI/TPI 1.

**LOAD CASE(S)** Standard



October 16, 2023

**WARNING - Verify design parameters and READ NOTES ON THIS AND INCLUDED MITEK REFERENCE PAGE MII-7473 rev. 1/2/2023 BEFORE USE.**

Design valid for use only with MiTek® connectors. This design is based only upon parameters shown, and is for an individual building component, not a truss system. Before use, the building designer must verify the applicability of design parameters and properly incorporate this design into the overall building design. Bracing indicated is to prevent buckling of individual truss web and/or chord members only. Additional temporary and permanent bracing is always required for stability and to prevent collapse with possible personal injury and property damage. For general guidance regarding the fabrication, storage, delivery, erection and bracing of trusses and truss systems, see **ANSI/TPI1 Quality Criteria and DSB-22** available from Truss Plate Institute (www.tpinst.org) and **BCSI Building Component Safety Information** available from the Structural Building Component Association (www.sbcacomponents.com)



818 Soundside Road  
Edenton, NC 27932

Job ELV B CP 3CG	Truss G01	Truss Type Common	Qty 2	Ply 1	Chesapeake Homes 628 Roof Job Reference (optional)	161390506
---------------------	--------------	----------------------	----------	----------	---	-----------

Builders FirstSource (Apex, NC), Apex, NC - 27523,

Run: 8.63 S Aug 30 2023 Print: 8.630 S Aug 30 2023 MiTek Industries, Inc. Thu Oct 12 18:28:17  
ID:u8TZMNQp8Y0oyef?k\_ppizylLdt-RfC?PsB70Hq3NSgPqnL8w3uITXbGKWrCDoi7J4zJC?f

Page: 1

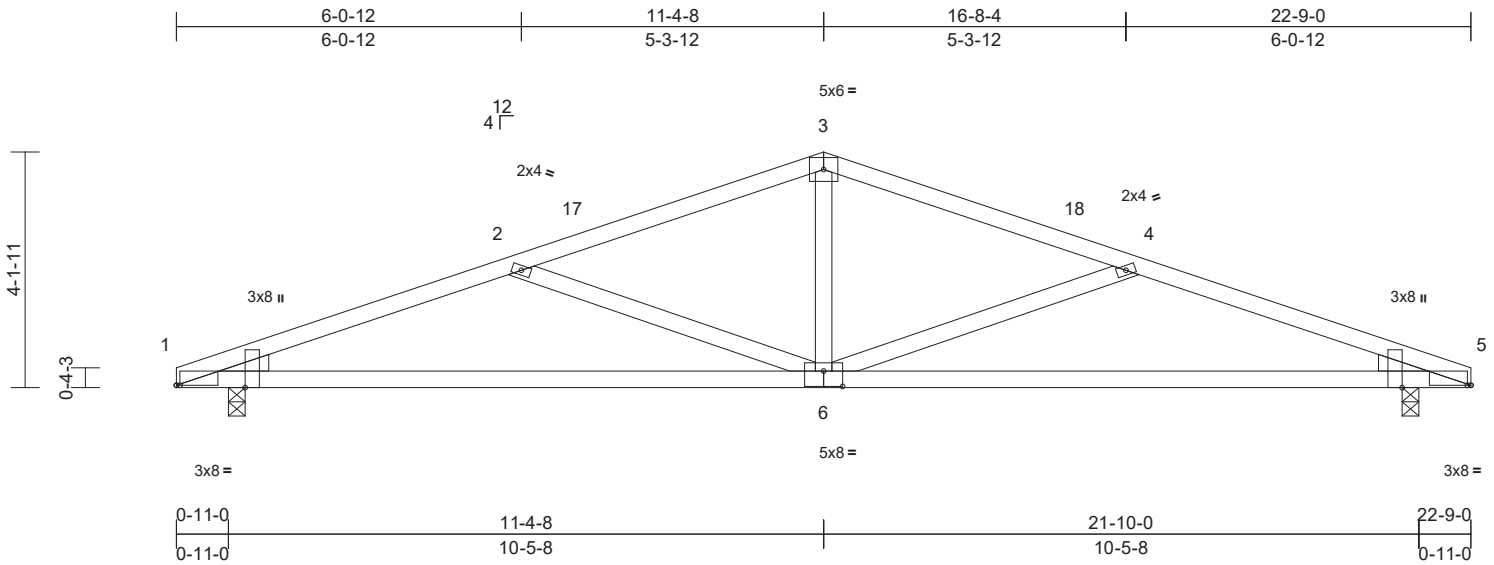

Scale = 1:40.5

Plate Offsets (X, Y): [1:0-0-12,Edge], [1:0-0-8,Edge], [5:0-0-12,Edge], [5:0-0-8,Edge], [6:0-4-0,0-3-4]

Loading	(psf)	Spacing	2-0-0	CSI	DEFL	in	(loc)	l/defl	L/d	PLATES	GRIP	
TCLL (roof)	20.0	Plate Grip DOL	1.00	TC	0.55	Vert(LL)	-0.15	6-11	>999	240	MT20	244/190
Snow (Ps/Pf)	17.2/20.0	Lumber DOL	1.15	BC	0.91	Vert(CT)	-0.31	6-11	>880	180		
TCDL	10.0	Rep Stress Incr	YES	WB	0.29	Horz(CT)	0.05	5	n/a	n/a		
BCLL	0.0*	Code	IRC2015/TPI2014	Matrix-MS								
BCDL	10.0											
											Weight: 94 lb	FT = 20%

**LUMBER**

TOP CHORD 2x4 SP No.2  
 BOT CHORD 2x4 SP No.2  
 WEBS 2x4 SP No.3  
 WEDGE Left: 2x4 SP No.3  
 Right: 2x4 SP No.3

**BRACING**

TOP CHORD Structural wood sheathing directly applied or 4-1-5 oc purlins.  
 BOT CHORD Rigid ceiling directly applied or 10-0-0 oc bracing.

**REACTIONS** (size) 1=0-3-8, 5=0-3-8

Max Horiz 1=50 (LC 16)  
 Max Uplift 1=-43 (LC 12), 5=-43 (LC 13)  
 Max Grav 1=910 (LC 2), 5=910 (LC 2)

**FORCES** (lb) - Maximum Compression/Maximum Tension

TOP CHORD 1-2=-1697/262, 2-3=-1304/164,  
 3-4=-1304/164, 4-5=-1697/262  
 BOT CHORD 1-5=-194/1564  
 WEBS 3-6=0/523, 2-6=-446/152, 4-6=-446/152

**NOTES**

- 1) Unbalanced roof live loads have been considered for this design.
- 2) Wind: ASCE 7-10; Vult=115mph (3-second gust) Vasd=91mph; TCDL=6.0psf; BCDL=6.0psf; h=30ft; Cat. II; Exp B; Enclosed; MWFRS (envelope) exterior zone and C-C Exterior (2) zone; cantilever left and right exposed; end vertical left and right exposed; C-C for members and forces & MWFRS for reactions shown; Lumber DOL=1.60 plate grip DOL=1.33
- 3) TCLL: ASCE 7-10; Pr=20.0 psf (roof live load: Lumber DOL=1.15 Plate DOL=1.00); Pf=20.0 psf (flat roof snow); Ps=17.2 psf (roof snow: Lumber DOL=1.15 Plate DOL=1.00); Category II; Exp B; Fully Exp.; Ct=1.10; Unobstructed slippery surface

- 4) Roof design snow load has been reduced to account for slope.
- 5) Unbalanced snow loads have been considered for this design.
- 6) This truss has been designed for a 10.0 psf bottom chord live load nonconcurrent with any other live loads.
- 7) \* This truss has been designed for a live load of 20.0psf on the bottom chord in all areas where a rectangle 3-06-00 tall by 2-00-00 wide will fit between the bottom chord and any other members.
- 8) All bearings are assumed to be SP No.2 crushing capacity of 565 psi.
- 9) Provide mechanical connection (by others) of truss to bearing plate capable of withstanding 43 lb uplift at joint 1 and 43 lb uplift at joint 5.
- 10) This truss is designed in accordance with the 2015 International Residential Code sections R502.11.1 and R802.10.2 and referenced standard ANSI/TPI 1.

**LOAD CASE(S)** Standard



October 16, 2023

**WARNING - Verify design parameters and READ NOTES ON THIS AND INCLUDED MITEK REFERENCE PAGE MII-7473 rev. 1/2/2023 BEFORE USE.**

Design valid for use only with MiTek® connectors. This design is based only upon parameters shown, and is for an individual building component, not a truss system. Before use, the building designer must verify the applicability of design parameters and properly incorporate this design into the overall building design. Bracing indicated is to prevent buckling of individual truss web and/or chord members only. Additional temporary and permanent bracing is always required for stability and to prevent collapse with possible personal injury and property damage. For general guidance regarding the fabrication, storage, delivery, erection and bracing of trusses and truss systems, see **ANSI/TPI1 Quality Criteria and DSB-22** available from Truss Plate Institute (www.tpinst.org) and **BCSI Building Component Safety Information** available from the Structural Building Component Association (www.sbcacomponents.com)



818 Soundside Road  
 Edenton, NC 27932

Job ELV B CP 3CG	Truss G01G	Truss Type Common Supported Gable	Qty 1	Ply 1	Chesapeake Homes 628 Roof Job Reference (optional)	161390507
---------------------	---------------	--------------------------------------	----------	----------	---	-----------

Builders FirstSource (Apex, NC), Apex, NC - 27523,

Run: 8.63 S Aug 30 2023 Print: 8.630 S Aug 30 2023 MiTek Industries, Inc. Thu Oct 12 18:28:17  
ID:mvi4BkTKmXERFzmzqt!spylLdp-RfC?PsB70Hq3NSgPqnL8w3uTXbGKWRcDol7J4zJC?f

Page: 1

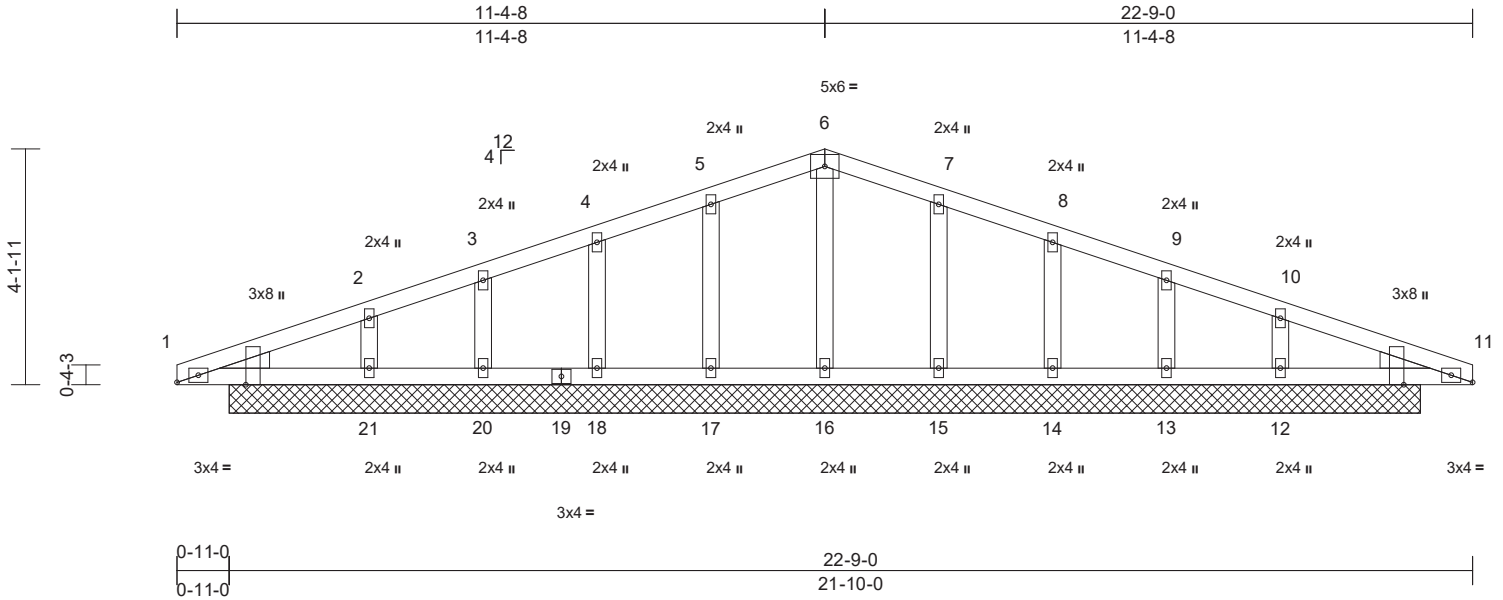

Scale = 1:40.5  
Plate Offsets (X, Y): [1:0-2-8,Edge], [1:0-0-8,Edge], [11:0-2-8,Edge], [11:0-0-8,Edge]

Loading	(psf)	Spacing	2-0-0	CSI	DEFL	in	(loc)	l/defl	L/d	PLATES	GRIP	
TCLL (roof)	20.0	Plate Grip DOL	1.00	TC	0.06	Vert(LL)	n/a	-	n/a	999	MT20	244/190
Snow (Ps/Pf)	17.2/20.0	Lumber DOL	1.15	BC	0.04	Vert(TL)	n/a	-	n/a	999		
TCDL	10.0	Rep Stress Incr	YES	WB	0.04	Horiz(TL)	0.00	11	n/a	n/a		
BCLL	0.0*	Code	IRC2015/TPI2014	Matrix-MS								
BCDL	10.0											
											Weight: 101 lb	FT = 20%

**LUMBER**  
TOP CHORD 2x4 SP No.2  
BOT CHORD 2x4 SP No.2  
OTHERS 2x4 SP No.3  
WEDGE Left: 2x4 SP No.3  
Right: 2x4 SP No.3

**BRACING**  
TOP CHORD Structural wood sheathing directly applied or 6-0-0 oc purlins.  
BOT CHORD Rigid ceiling directly applied or 10-0-0 oc bracing.

**REACTIONS** (size)  
1=20-11-0, 11=20-11-0,  
12=20-11-0, 13=20-11-0,  
14=20-11-0, 15=20-11-0,  
16=20-11-0, 17=20-11-0,  
18=20-11-0, 20=20-11-0,  
21=20-11-0, 24=20-11-0,  
29=20-11-0  
Max Horiz 1=-50 (LC 17), 24=-50 (LC 17)  
Max Uplift 11=-1 (LC 13), 12=-32 (LC 17),  
13=-16 (LC 13), 14=-20 (LC 13),  
15=-21 (LC 17), 17=-21 (LC 16),  
18=-20 (LC 16), 20=-15 (LC 12),  
21=-36 (LC 16), 29=-1 (LC 13)  
Max Grav 1=180 (LC 2), 11=180 (LC 2),  
12=183 (LC 34), 13=154 (LC 2),  
14=167 (LC 23), 15=199 (LC 23),  
16=137 (LC 2), 17=199 (LC 22),  
18=167 (LC 22), 20=154 (LC 2),  
21=183 (LC 33), 24=180 (LC 2),  
29=180 (LC 2)

**FORCES** (lb) - Maximum Compression/Maximum Tension  
TOP CHORD 1-2=-52/30, 2-3=-45/40, 3-4=-38/52,  
4-5=-38/67, 5-6=-47/91, 6-7=-47/91,  
7-8=-38/67, 8-9=-38/43, 9-10=-38/20,  
10-11=-33/15

**BOT CHORD** 1-21=-23/40, 20-21=-2/40, 18-20=-2/40,  
17-18=-2/40, 16-17=-2/40, 15-16=-2/40,  
14-15=-2/40, 13-14=-2/40, 12-13=-2/40,  
11-12=-5/40  
**WEBS** 6-16=-97/0, 5-17=-159/51, 4-18=-126/51,  
3-20=-118/49, 2-21=-128/54, 7-15=-159/51,  
8-14=-126/51, 9-13=-118/49, 10-12=-128/54

**NOTES**  
1) Unbalanced roof live loads have been considered for this design.  
2) Wind: ASCE 7-10; Vult=115mph (3-second gust) Vasd=91mph; TCCL=6.0psf; BCDL=6.0psf; h=30ft; Cat. II; Exp B; Enclosed; MWFRS (envelope) exterior zone and C-C Exterior (2) zone; cantilever left and right exposed; end vertical left and right exposed; C-C for members and forces & MWFRS for reactions shown; Lumber DOL=1.60 plate grip DOL=1.33  
3) Truss designed for wind loads in the plane of the truss only. For studs exposed to wind (normal to the face), see Standard Industry Gable End Details as applicable, or consult qualified building designer as per ANSI/TPI 1.  
4) TCLL: ASCE 7-10; Pr=20.0 psf (roof live load: Lumber DOL=1.15 Plate DOL=1.00); Pf=20.0 psf (flat roof snow); Ps=17.2 psf (roof snow: Lumber DOL=1.15 Plate DOL=1.00); Category II; Exp B; Fully Exp.; Ct=1.10; Unobstructed slippery surface  
5) Roof design snow load has been reduced to account for slope.  
6) Unbalanced snow loads have been considered for this design.  
7) Gable studs spaced at 2-0-0 oc.  
8) This truss has been designed for a 10.0 psf bottom chord live load nonconcurrent with any other live loads.  
9) \* This truss has been designed for a live load of 20.0psf on the bottom chord in all areas where a rectangle 3-06-00 tall by 2-00-00 wide will fit between the bottom chord and any other members.

10) All bearings are assumed to be SP No.2 crushing capacity of 565 psi.  
11) Provide mechanical connection (by others) of truss to bearing plate capable of withstanding 1 lb uplift at joint 11, 21 lb uplift at joint 17, 20 lb uplift at joint 18, 15 lb uplift at joint 20, 36 lb uplift at joint 21, 21 lb uplift at joint 15, 20 lb uplift at joint 14, 16 lb uplift at joint 13, 32 lb uplift at joint 12 and 1 lb uplift at joint 11.  
12) Non Standard bearing condition. Review required.  
13) This truss is designed in accordance with the 2015 International Residential Code sections R502.11.1 and R802.10.2 and referenced standard ANSI/TPI 1.

**LOAD CASE(S)** Standard



October 16, 2023

**WARNING - Verify design parameters and READ NOTES ON THIS AND INCLUDED MITEK REFERENCE PAGE MII-7473 rev. 1/2/2023 BEFORE USE.**

Design valid for use only with MiTek® connectors. This design is based only upon parameters shown, and is for an individual building component, not a truss system. Before use, the building designer must verify the applicability of design parameters and properly incorporate this design into the overall building design. Bracing indicated is to prevent buckling of individual truss web and/or chord members only. Additional temporary and permanent bracing is always required for stability and to prevent collapse with possible personal injury and property damage. For general guidance regarding the fabrication, storage, delivery, erection and bracing of trusses and truss systems, see **ANSI/TPI1 Quality Criteria and DSB-22** available from Truss Plate Institute (www.tpinst.org) and **BCSI Building Component Safety Information** available from the Structural Building Component Association (www.sbcacomponents.com)



818 Soundside Road  
Edenton, NC 27932

Job ELV B CP 3CG	Truss J01	Truss Type Jack-Open	Qty 4	Ply 1	Chesapeake Homes 628 Roof Job Reference (optional)	I61390509
---------------------	--------------	-------------------------	----------	----------	---	-----------

Builders FirstSource (Apex, NC), Apex, NC - 27523,

Run: 8.63 S Aug 30 2023 Print: 8.630 S Aug 30 2023 MiTek Industries, Inc. Thu Oct 12 18:28:18  
ID:KC8IrtP5zqvCkTm7\_V9gMlzd28L-RfC?PsB70Hq3NSgPqnL8w3ulTXbGKWrcDoi7J4zJC?f

Page: 1

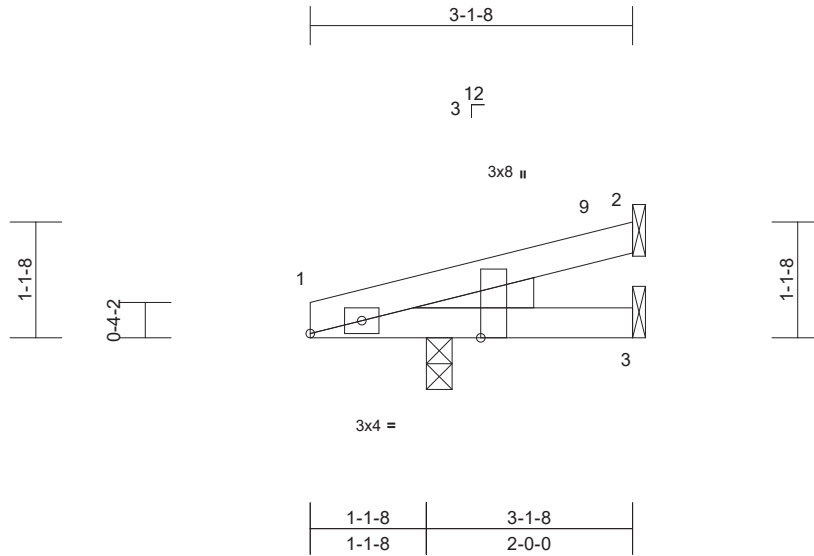

Scale = 1:22.3

Plate Offsets (X, Y): [1:0-4-0,Edge], [1:0-0-8,Edge]

Loading	(psf)	Spacing	2-0-0	CSI	DEFL	in	(loc)	l/defl	L/d	PLATES	GRIP	
TCLL (roof)	20.0	Plate Grip DOL	1.00	TC	0.06	Vert(LL)	0.00	4	>999	240	MT20	244/190
Snow (Ps/Pf)	18.7/20.0	Lumber DOL	1.15	BC	0.05	Vert(CT)	0.00	4	>999	180		
TCDL	10.0	Rep Stress Incr	YES	WB	0.00	Horz(CT)	0.00	1	n/a	n/a		
BCLL	0.0*	Code	IRC2015/TPI2014	Matrix-MP								
BCDL	10.0										Weight: 11 lb	FT = 20%

#### LUMBER

TOP CHORD 2x4 SP No.2  
BOT CHORD 2x4 SP No.2  
WEDGE Left: 2x4 SP No.3

#### BRACING

TOP CHORD Structural wood sheathing directly applied or 3-1-8 oc purlins.  
BOT CHORD Rigid ceiling directly applied or 10-0-0 oc bracing.

#### REACTIONS

(size) 1=0-3-0, 2= Mechanical, 3= Mechanical  
Max Horiz 1=23 (LC 12)  
Max Uplift 1=-10 (LC 12), 2=-10 (LC 12)  
Max Grav 1=194 (LC 2), 2=32 (LC 2), 3=23 (LC 7)

#### FORCES

(lb) - Maximum Compression/Maximum Tension

TOP CHORD 1-2=-7/28  
BOT CHORD 1-3=-19/0

#### NOTES

- 1) Wind: ASCE 7-10; Vult=115mph (3-second gust) Vasd=91mph; TCDL=6.0psf, BCDL=6.0psf; h=30ft; Cat. II; Exp B; Enclosed; MWFRS (envelope) exterior zone and C-C Exterior (2) zone; cantilever left and right exposed; end vertical left and right exposed; C-C for members and forces & MWFRS for reactions shown; Lumber DOL=1.60 plate grip DOL=1.33
- 2) TCLL: ASCE 7-10; Pr=20.0 psf (roof live load: Lumber DOL=1.15 Plate DOL=1.00); Pf=20.0 psf (flat roof snow); Ps=18.7 psf (roof snow: Lumber DOL=1.15 Plate DOL=1.00); Category II; Exp B; Fully Exp.; Ct=1.10; Unobstructed slippery surface
- 3) Roof design snow load has been reduced to account for slope.
- 4) Unbalanced snow loads have been considered for this design.

- 5) This truss has been designed for a 10.0 psf bottom chord live load nonconcurrent with any other live loads.
- 6) \* This truss has been designed for a live load of 20.0psf on the bottom chord in all areas where a rectangle 3-06-00 tall by 2-00-00 wide will fit between the bottom chord and any other members.
- 7) Bearings are assumed to be: , Joint 1 SP No.2 crushing capacity of 565 psi.
- 8) Refer to girder(s) for truss to truss connections.
- 9) Provide mechanical connection (by others) of truss to bearing plate capable of withstanding 10 lb uplift at joint 2 and 10 lb uplift at joint 1.
- 10) This truss is designed in accordance with the 2015 International Residential Code sections R502.11.1 and R802.10.2 and referenced standard ANSI/TPI 1.

LOAD CASE(S) Standard

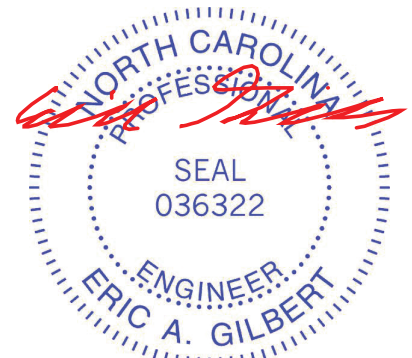

October 16, 2023

**WARNING - Verify design parameters and READ NOTES ON THIS AND INCLUDED MITEK REFERENCE PAGE MII-7473 rev. 1/2/2023 BEFORE USE.**

Design valid for use only with MiTek® connectors. This design is based only upon parameters shown, and is for an individual building component, not a truss system. Before use, the building designer must verify the applicability of design parameters and properly incorporate this design into the overall building design. Bracing indicated is to prevent buckling of individual truss web and/or chord members only. Additional temporary and permanent bracing is always required for stability and to prevent collapse with possible personal injury and property damage. For general guidance regarding the fabrication, storage, delivery, erection and bracing of trusses and truss systems, see **ANSI/TPI1 Quality Criteria and DSB-22** available from Truss Plate Institute ([www.tpinst.org](http://www.tpinst.org)) and **BCSI Building Component Safety Information** available from the Structural Building Component Association ([www.sbcacomponents.com](http://www.sbcacomponents.com))

ENGINEERING BY  
**TRENCO**  
A MiTek Affiliate

818 Soundside Road  
Edenton, NC 27932



Job ELV B CP 3CG	Truss J02	Truss Type Half Hip	Qty 2	Ply 1	Chesapeake Homes 628 Roof Job Reference (optional)	161390510
---------------------	--------------	------------------------	----------	----------	---	-----------

Builders FirstSource (Apex, NC), Apex, NC - 27523,

Run: 8.63 S Aug 30 2023 Print: 8.630 S Aug 30 2023 MiTek Industries, Inc. Thu Oct 12 18:28:18  
ID:znOGwolH7KY5iwUib5AT2Pzd27u-RfC?PsB70Hq3NSgPqnL8w3uITXbGKWrCDoi7J4zJC7f

Page: 1

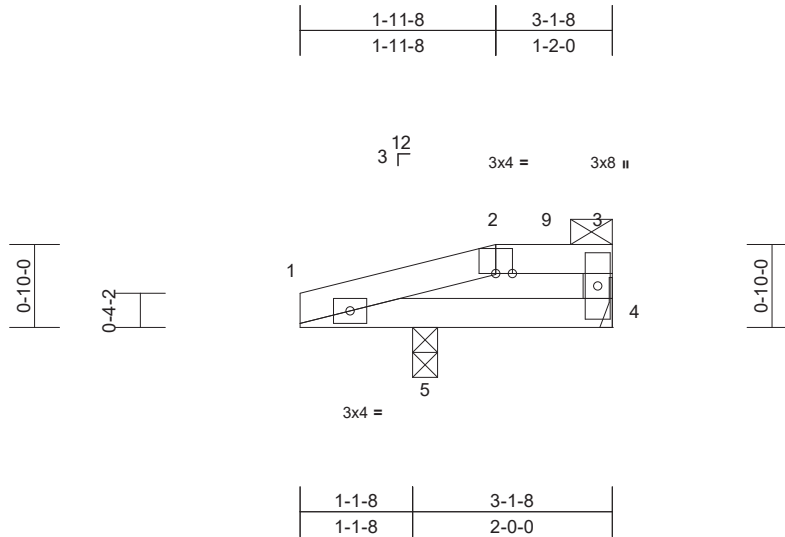

Scale = 1:23.1

Loading	(psf)	Spacing	2-0-0	CSI	DEFL	in	(loc)	l/defl	L/d	PLATES	GRIP	
TCLL (roof)	20.0	Plate Grip DOL	1.00	TC	0.11	Vert(LL)	0.00	4-5	>999	240	MT20	244/190
Snow (Ps/Pf)	18.7/20.0	Lumber DOL	1.15	BC	0.09	Vert(CT)	0.00	4-5	>999	180		
TCDL	10.0	Rep Stress Incr	YES	WB	0.00	Horz(CT)	0.00	4	n/a	n/a		
BCLL	0.0*	Code	IRC2015/TPI2014	Matrix-MR								
BCDL	10.0										Weight: 10 lb	FT = 20%

**LUMBER**  
TOP CHORD 2x4 SP No.2  
BOT CHORD 2x4 SP No.2  
WEBS 2x4 SP No.3

**BRACING**  
TOP CHORD Structural wood sheathing directly applied or 3-1-8 oc purlins, except end verticals, and 2-0-0 oc purlins: 2-3.  
BOT CHORD Rigid ceiling directly applied or 6-0-0 oc bracing.

**REACTIONS** (size) 4= Mechanical, 5=0-3-0  
Max Horiz 5=17 (LC 15)  
Max Uplift 4=9 (LC 13), 5=-39 (LC 12)  
Max Grav 4=64 (LC 34), 5=261 (LC 35)

**FORCES** (lb) - Maximum Compression/Maximum Tension  
TOP CHORD 1-2=-28/50, 2-3=-28/42, 3-4=-64/26  
BOT CHORD 1-5=-42/51, 4-5=-42/37

6) Provide adequate drainage to prevent water ponding.  
7) This truss has been designed for a 10.0 psf bottom chord live load nonconcurrent with any other live loads.  
8) \* This truss has been designed for a live load of 20.0psf on the bottom chord in all areas where a rectangle 3-06-00 tall by 2-00-00 wide will fit between the bottom chord and any other members.  
9) Bearings are assumed to be: Joint 5 SP No.2 crushing capacity of 565 psi.  
10) Refer to girder(s) for truss to truss connections.  
11) Provide mechanical connection (by others) of truss to bearing plate capable of withstanding 9 lb uplift at joint 4 and 39 lb uplift at joint 5.  
12) This truss is designed in accordance with the 2015 International Residential Code sections R502.11.1 and R802.10.2 and referenced standard ANSI/TPI 1.  
13) Graphical purlin representation does not depict the size or the orientation of the purlin along the top and/or bottom chord.

**LOAD CASE(S)** Standard  
1) Dead + Snow (balanced): Lumber Increase=1.15, Plate Increase=1.00  
Uniform Loads (lb/ft)  
Vert: 1-2=-57, 2-3=-60, 4-6=-20

**NOTES**  
1) Unbalanced roof live loads have been considered for this design.  
2) Wind: ASCE 7-10; Vult=115mph (3-second gust) Vasd=91mph; TCDL=6.0psf; BCDL=6.0psf; h=30ft; Cat. II; Exp B; Enclosed; MWFRS (envelope) exterior zone and C-C Exterior (2) zone; cantilever left and right exposed; end vertical left and right exposed; C-C for members and forces & MWFRS for reactions shown; Lumber DOL=1.60 plate grip DOL=1.33  
3) \*\* TCLL: ASCE 7-10; Pr=20.0 psf (roof live load: Lumber DOL=1.15 Plate DOL=1.00); Pf=20.0 psf (flat roof snow); Ps= varies (min. roof snow=18.7 psf Lumber DOL=1.15 Plate DOL=1.00) see load cases; Category II; Exp B; Fully Exp.; Ct=1.10; Unobstructed slippery surface  
4) Roof design snow load has been reduced to account for slope.  
5) Unbalanced snow loads have been considered for this design.



October 16, 2023

**WARNING - Verify design parameters and READ NOTES ON THIS AND INCLUDED MITEK REFERENCE PAGE MII-7473 rev. 1/2/2023 BEFORE USE.**

Design valid for use only with MiTek® connectors. This design is based only upon parameters shown, and is for an individual building component, not a truss system. Before use, the building designer must verify the applicability of design parameters and properly incorporate this design into the overall building design. Bracing indicated is to prevent buckling of individual truss web and/or chord members only. Additional temporary and permanent bracing is always required for stability and to prevent collapse with possible personal injury and property damage. For general guidance regarding the fabrication, storage, delivery, erection and bracing of trusses and truss systems, see **ANSI/TPI1 Quality Criteria and DSB-22** available from Truss Plate Institute (www.tpinst.org) and **BCSI Building Component Safety Information** available from the Structural Building Component Association (www.sbccomponents.com)

ENGINEERING BY  
**TRENCO**  
A MITEK Affiliate

818 Soundside Road  
Edenton, NC 27932

Job ELV B CP 3CG	Truss P01	Truss Type Monopitch	Qty 6	Ply 1	Chesapeake Homes 628 Roof Job Reference (optional)	161390514
---------------------	--------------	-------------------------	----------	----------	---	-----------

Builders FirstSource (Apex, NC), Apex, NC - 27523,

Run: 8.63 S Aug 30 2023 Print: 8.630 S Aug 30 2023 MiTek Industries, Inc. Thu Oct 12 18:28:19  
ID:3Ap?JDGLaUK7G\_D2E4krwQzIBJ0-RfC?PsB70Hq3NSgPqnL8w3ulTXbGKWRCdoi7J4zJC?f

Page: 1

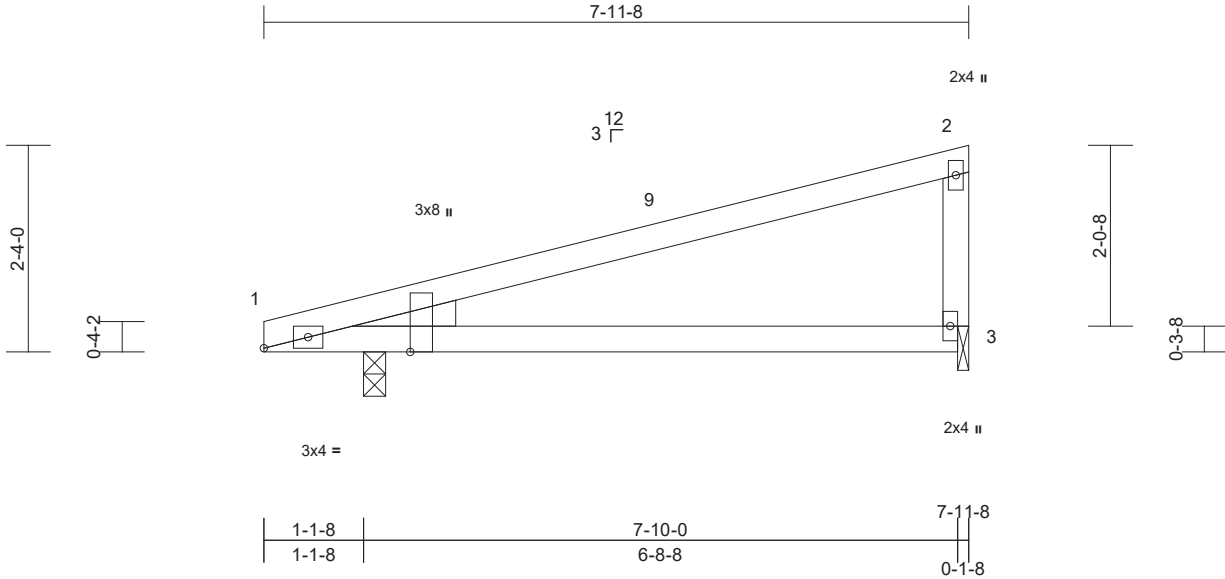

Scale = 1:26

Plate Offsets (X, Y): [1:0-4-0,Edge], [1:0-0-8,Edge]

Loading	(psf)	Spacing	2-0-0	CSI	DEFL	in	(loc)	l/defl	L/d	PLATES	GRIP	
TCLL (roof)	20.0	Plate Grip DOL	1.00	TC	0.70	Vert(LL)	-0.10	3-8	>966	240	MT20	244/190
Snow (Ps/Pf)	18.7/20.0	Lumber DOL	1.15	BC	0.55	Vert(CT)	-0.21	3-8	>451	180		
TCDL	10.0	Rep Stress Incr	YES	WB	0.00	Horz(CT)	0.01	1	n/a	n/a		
BCLL	0.0*	Code	IRC2015/TPI2014	Matrix-MP								
BCDL	10.0											
											Weight: 28 lb	FT = 20%

#### LUMBER

TOP CHORD 2x4 SP No.2  
BOT CHORD 2x4 SP No.2  
WEBS 2x4 SP No.3  
WEDGE Left: 2x4 SP No.3

#### BRACING

TOP CHORD Structural wood sheathing directly applied or 6-0-0 oc purlins, except end verticals.  
BOT CHORD Rigid ceiling directly applied or 10-0-0 oc bracing.

**REACTIONS** (size) 1=0-3-0, 3=0-1-8  
Max Horiz 1=63 (LC 15)  
Max Uplift 1=-24 (LC 12), 3=-25 (LC 16)  
Max Grav 1=365 (LC 2), 3=279 (LC 23)

#### FORCES

(lb) - Maximum Compression/Maximum Tension  
TOP CHORD 1-2=-89/45, 2-3=-190/87  
BOT CHORD 1-3=-91/109

#### NOTES

- 1) Wind: ASCE 7-10; Vult=115mph (3-second gust)  
Vasd=91mph; TCDL=6.0psf; BCDL=6.0psf; h=30ft; Cat. II; Exp B; Enclosed; MWFRS (envelope) exterior zone and C-C Exterior (2) zone; cantilever left and right exposed; end vertical left and right exposed; C-C for members and forces & MWFRS for reactions shown; Lumber DOL=1.60 plate grip DOL=1.33
- 2) TCLL: ASCE 7-10; Pr=20.0 psf (roof live load: Lumber DOL=1.15 Plate DOL=1.00); Pf=20.0 psf (flat roof snow); Ps=18.7 psf (roof snow: Lumber DOL=1.15 Plate DOL=1.00); Category II; Exp B; Fully Exp.; Ct=1.10; Unobstructed slippery surface
- 3) Roof design snow load has been reduced to account for slope.
- 4) Unbalanced snow loads have been considered for this design.
- 5) This truss has been designed for a 10.0 psf bottom chord live load nonconcurrent with any other live loads.

- 6) \* This truss has been designed for a live load of 20.0psf on the bottom chord in all areas where a rectangle 3-06-00 tall by 2-00-00 wide will fit between the bottom chord and any other members.
- 7) Bearings are assumed to be: Joint 1 SP No.2 crushing capacity of 565 psi, Joint 3 SP No.3 crushing capacity of 565 psi.
- 8) Bearing at joint(s) 3 considers parallel to grain value using ANSI/TPI 1 angle to grain formula. Building designer should verify capacity of bearing surface.
- 9) Provide mechanical connection (by others) of truss to bearing plate at joint(s) 3.
- 10) Provide mechanical connection (by others) of truss to bearing plate capable of withstanding 24 lb uplift at joint 1 and 25 lb uplift at joint 3.
- 11) This truss is designed in accordance with the 2015 International Residential Code sections R502.11.1 and R802.10.2 and referenced standard ANSI/TPI 1.

**LOAD CASE(S)** Standard



October 16, 2023

**WARNING - Verify design parameters and READ NOTES ON THIS AND INCLUDED MITEK REFERENCE PAGE MII-7473 rev. 1/2/2023 BEFORE USE.**

Design valid for use only with MiTek® connectors. This design is based only upon parameters shown, and is for an individual building component, not a truss system. Before use, the building designer must verify the applicability of design parameters and properly incorporate this design into the overall building design. Bracing indicated is to prevent buckling of individual truss web and/or chord members only. Additional temporary and permanent bracing is always required for stability and to prevent collapse with possible personal injury and property damage. For general guidance regarding the fabrication, storage, delivery, erection and bracing of trusses and truss systems, see **ANSI/TPI1 Quality Criteria and DSB-22** available from Truss Plate Institute (www.tpinst.org) and **BCSI Building Component Safety Information** available from the Structural Building Component Association (www.sbcacomponents.com)

ENGINEERING BY  
**TRENCO**  
A MiTek Affiliate

818 Soundside Road  
Edenton, NC 27932

Job ELV B CP 3CG	Truss P02	Truss Type Half Hip Girder	Qty 2	Ply 1	Chesapeake Homes 628 Roof Job Reference (optional)	I61390515
---------------------	--------------	-------------------------------	----------	----------	---	-----------

Builders FirstSource (Apex, NC), Apex, NC - 27523,

Run: 8.63 S Aug 30 2023 Print: 8.630 S Aug 30 2023 MiTek Industries, Inc. Thu Oct 12 18:28:19  
ID:3Ap?JDGLaUK7G\_D2E4krwQzIBJ0-RfC?PsB70Hq3NSgPqnL8w3ulTXbGKWrcDoi7J4zJC?f

Page: 1

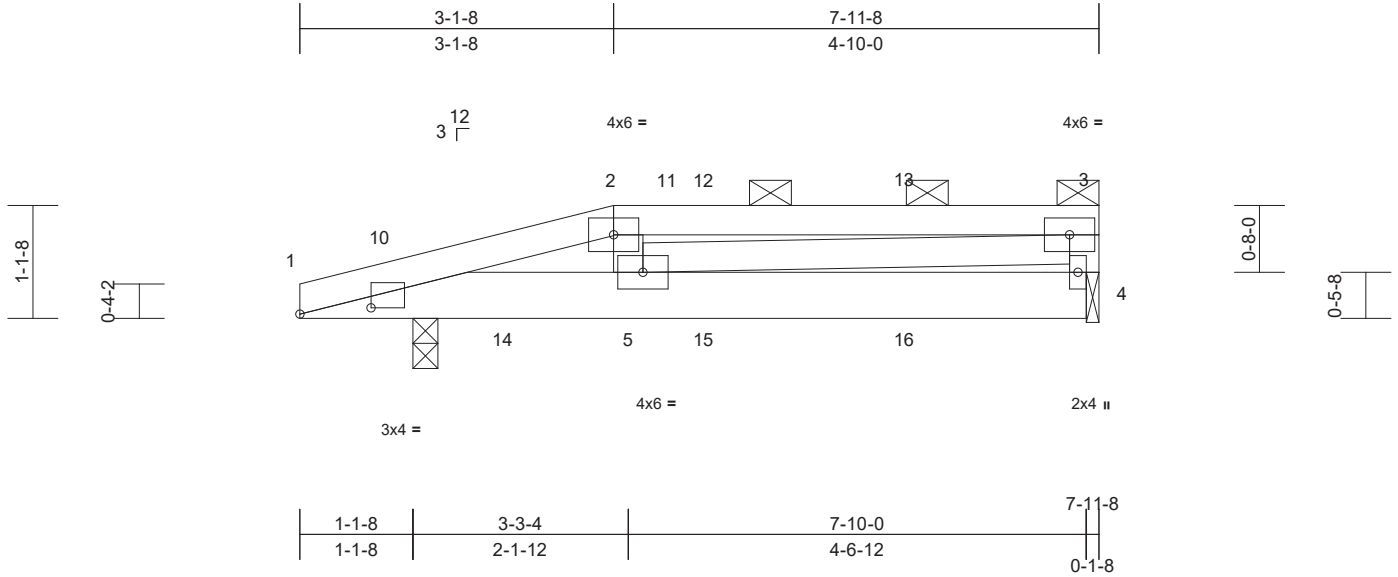

Scale = 1:22.9  
Plate Offsets (X, Y): [1:0-8-8,0-0-12]

Loading	(psf)	Spacing	2-0-0	CSI	DEFL	in	(loc)	l/defl	L/d	PLATES	GRIP	
TCLL (roof)	20.0	Plate Grip DOL	1.00	TC	0.79	Vert(LL)	-0.01	4-5	>999	240	MT20	244/190
Snow (Ps/Pf)	18.7/20.0	Lumber DOL	1.15	BC	0.16	Vert(CT)	-0.02	4-5	>999	180		
TCDL	10.0	Rep Stress Incr	NO	WB	0.19	Horz(CT)	0.00	4	n/a	n/a		
BCLL	0.0*	Code	IRC2015/TPI2014	Matrix-MP								
BCDL	10.0											
											Weight: 38 lb	FT = 20%

**LUMBER**  
TOP CHORD 2x4 SP No.2  
BOT CHORD 2x6 SP No.2  
WEBS 2x4 SP No.3

**BRACING**  
TOP CHORD Structural wood sheathing directly applied or 6-0-0 oc purlins, except end verticals, and 2-0-0 oc purlins (5-10-10 max.): 2-3.  
BOT CHORD Rigid ceiling directly applied or 10-0-0 oc bracing.

**REACTIONS** (size) 1=0-3-0, 4=0-1-8  
Max Horiz 1=25 (LC 9)  
Max Uplift 1=-45 (LC 8), 4=-23 (LC 8)  
Max Grav 1=460 (LC 32), 4=354 (LC 31)

**FORCES** (lb) - Maximum Compression/Maximum Tension  
TOP CHORD 1-2=-502/82, 2-3=-458/18, 3-4=-288/45  
BOT CHORD 1-5=-62/478, 4-5=-8/6  
WEBS 2-5=-102/51, 3-5=-12/464

**NOTES**

- Unbalanced roof live loads have been considered for this design.
- Wind: ASCE 7-10; Vult=115mph (3-second gust) Vasd=91mph; TCDL=6.0psf; BCDL=6.0psf; h=30ft; Cat. II; Exp B; Enclosed; MWFRS (envelope) exterior zone; cantilever left and right exposed; end vertical left and right exposed; Lumber DOL=1.60 plate grip DOL=1.33
- \*\* TCLL: ASCE 7-10; Pr=20.0 psf (roof live load: Lumber DOL=1.15 Plate DOL=1.00); Pf=20.0 psf (flat roof snow); Ps= varies (min. roof snow=18.7 psf Lumber DOL=1.15 Plate DOL=1.00) see load cases; Category II; Exp B; Fully Exp.; Ct=1.10; Unobstructed slippery surface
- Roof design snow load has been reduced to account for slope.
- Unbalanced snow loads have been considered for this design.

- Provide adequate drainage to prevent water ponding.
- This truss has been designed for a 10.0 psf bottom chord live load nonconcurrent with any other live loads.
- \* This truss has been designed for a live load of 20.0psf on the bottom chord in all areas where a rectangle 3-06-00 tall by 2-00-00 wide will fit between the bottom chord and any other members.
- Bearings are assumed to be: Joint 1 SP No.2 crushing capacity of 565 psi, Joint 4 SP No.3 crushing capacity of 565 psi.
- Bearing at joint(s) 4 considers parallel to grain value using ANSI/TPI 1 angle to grain formula. Building designer should verify capacity of bearing surface.
- Provide mechanical connection (by others) of truss to bearing plate at joint(s) 4.
- Provide mechanical connection (by others) of truss to bearing plate capable of withstanding 45 lb uplift at joint 1 and 23 lb uplift at joint 4.
- This truss is designed in accordance with the 2015 International Residential Code sections R502.11.1 and R802.10.2 and referenced standard ANSI/TPI 1.
- Graphical purlin representation does not depict the size or the orientation of the purlin along the top and/or bottom chord.
- Hanger(s) or other connection device(s) shall be provided sufficient to support concentrated load(s) 19 lb down and 6 lb up at 4-0-4, and 19 lb down and 6 lb up at 6-0-4 on top chord, and 48 lb down and 18 lb up at 2-0-4, and 6 lb down and 1 lb up at 4-0-4, and 6 lb down and 1 lb up at 6-0-4 on bottom chord. The design/selection of such connection device(s) is the responsibility of others.
- In the LOAD CASE(S) section, loads applied to the face of the truss are noted as front (F) or back (B).

**LOAD CASE(S)** Standard

- Dead + Snow (balanced): Lumber Increase=1.15, Plate Increase=1.00  
Uniform Loads (lb/ft)

Vert: 1-2=-57, 2-3=-60, 1-4=-20  
Concentrated Loads (lb)  
Vert: 14=-48 (B), 15=-6 (B), 16=-6 (B)

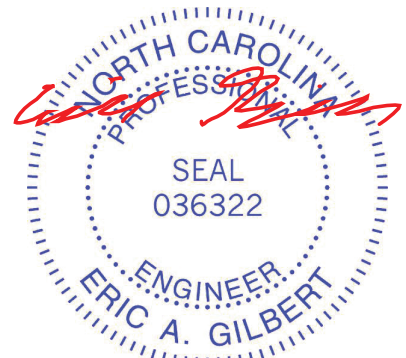

October 16, 2023

**WARNING - Verify design parameters and READ NOTES ON THIS AND INCLUDED MITEK REFERENCE PAGE MII-7473 rev. 1/2/2023 BEFORE USE.**

Design valid for use only with MiTek® connectors. This design is based only upon parameters shown, and is for an individual building component, not a truss system. Before use, the building designer must verify the applicability of design parameters and properly incorporate this design into the overall building design. Bracing indicated is to prevent buckling of individual truss web and/or chord members only. Additional temporary and permanent bracing is always required for stability and to prevent collapse with possible personal injury and property damage. For general guidance regarding the fabrication, storage, delivery, erection and bracing of trusses and truss systems, see **ANSI/TPI1 Quality Criteria and DSB-22** available from Truss Plate Institute (www.tpinst.org) and **BCSI Building Component Safety Information** available from the Structural Building Component Association (www.sbcacomponents.com)



818 Soundside Road  
Edenton, NC 27932

Job ELV B CP 3CG	Truss P03	Truss Type Half Hip	Qty 2	Ply 1	Chesapeake Homes 628 Roof Job Reference (optional)	161390516
---------------------	--------------	------------------------	----------	----------	---	-----------

Builders FirstSource (Apex, NC), Apex, NC - 27523,

Run: 8.63 S Aug 30 2023 Print: 8.630 S Aug 30 2023 MiTek Industries, Inc. Thu Oct 12 18:28:20  
ID:3Ap?JDGLaUK7G\_D2E4krwQzIBJ0-RfC?PsB70Hq3NSgPqnL8w3ulTXbGKWrCdoi7J4zJC?F

Page: 1

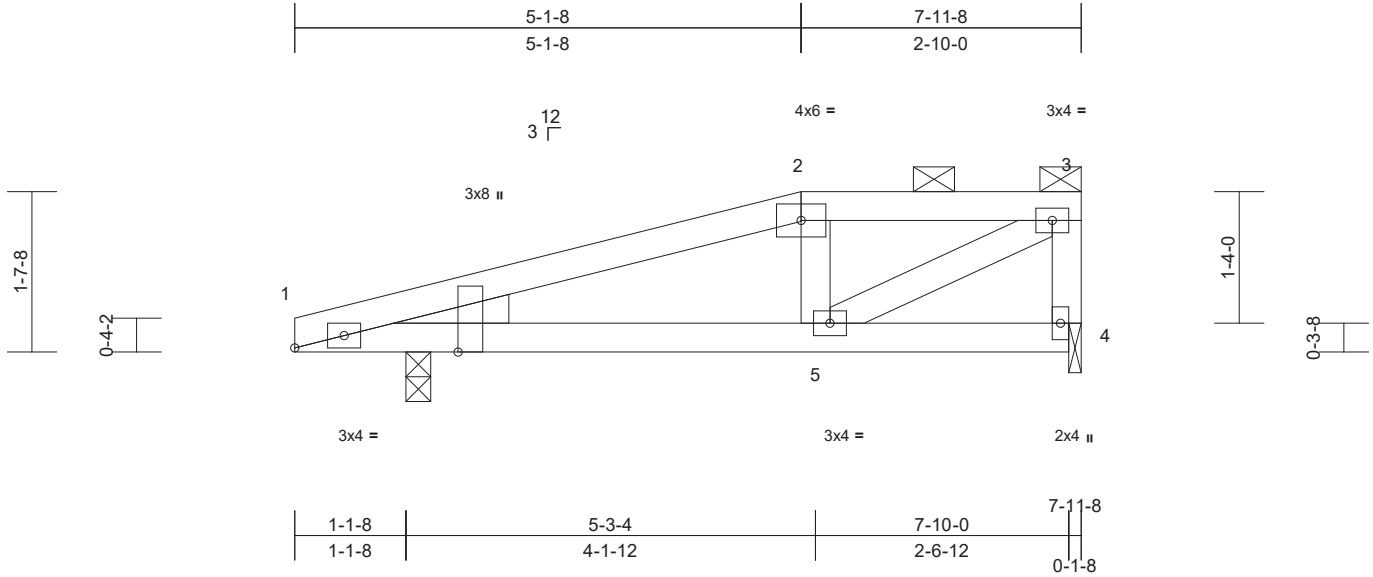

Scale = 1:23.3

Plate Offsets (X, Y): [1:0-4-0,Edge], [1:0-0-8,Edge]

Loading	(psf)	Spacing	2-0-0	CSI	DEFL	in	(loc)	l/defl	L/d	PLATES	GRIP	
TCLL (roof)	20.0	Plate Grip DOL	1.00	TC	0.21	Vert(LL)	-0.01	5-10	>999	240	MT20	244/190
Snow (Ps/Pf)	18.7/20.0	Lumber DOL	1.15	BC	0.21	Vert(CT)	-0.02	5-10	>999	180		
TCDL	10.0	Rep Stress Incr	YES	WB	0.16	Horz(CT)	0.00	4	n/a	n/a		
BCLL	0.0*	Code	IRC2015/TPI2014	Matrix-MP								
BCDL	10.0											
											Weight: 32 lb	FT = 20%

**LUMBER**  
TOP CHORD 2x4 SP No.2  
BOT CHORD 2x4 SP No.2  
WEBS 2x4 SP No.3  
WEDGE Left: 2x4 SP No.3

**BRACING**  
TOP CHORD Structural wood sheathing directly applied or 6-0-0 oc purlins, except end verticals, and 2-0-0 oc purlins (6-0-0 max.): 2-3.  
BOT CHORD Rigid ceiling directly applied or 10-0-0 oc bracing.

**REACTIONS** (size) 1=0-3-0, 4=0-1-8  
Max Horiz 1=42 (LC 15)  
Max Uplift 1=-27 (LC 12), 4=-22 (LC 12)  
Max Grav 1=463 (LC 36), 4=294 (LC 35)

**FORCES** (lb) - Maximum Compression/Maximum Tension  
TOP CHORD 1-2=-391/82, 2-3=-338/84, 3-4=-274/81  
BOT CHORD 1-5=-97/346, 4-5=-18/20  
WEBS 2-5=-88/66, 3-5=-87/381

**NOTES**

- Unbalanced roof live loads have been considered for this design.
- Wind: ASCE 7-10; Vult=115mph (3-second gust) Vasd=91mph; TCDL=6.0psf; BCDL=6.0psf; h=30ft; Cat. II; Exp B; Enclosed; MWFRS (envelope) exterior zone and C-C Exterior (2) zone; cantilever left and right exposed; end vertical left and right exposed; C-C for members and forces & MWFRS for reactions shown; Lumber DOL=1.60 plate grip DOL=1.33
- \*\* TCLL: ASCE 7-10; Pr=20.0 psf (roof live load: Lumber DOL=1.15 Plate DOL=1.00); Pf=20.0 psf (flat roof snow); Ps= varies (min. roof snow=18.7 psf Lumber DOL=1.15 Plate DOL=1.00) see load cases; Category II; Exp B; Fully Exp.; Ct=1.10; Unobstructed slippery surface

- Roof design snow load has been reduced to account for slope.
- Unbalanced snow loads have been considered for this design.
- Provide adequate drainage to prevent water ponding.
- This truss has been designed for a 10.0 psf bottom chord live load nonconcurrent with any other live loads.
- \* This truss has been designed for a live load of 20.0psf on the bottom chord in all areas where a rectangle 3-06-00 tall by 2-00-00 wide will fit between the bottom chord and any other members.
- Bearings are assumed to be: Joint 1 SP No.2 crushing capacity of 565 psi, Joint 4 SP No.3 crushing capacity of 565 psi.
- Bearing at joint(s) 4 considers parallel to grain value using ANSI/TPI 1 angle to grain formula. Building designer should verify capacity of bearing surface.
- Provide mechanical connection (by others) of truss to bearing plate at joint(s) 4.
- Provide mechanical connection (by others) of truss to bearing plate capable of withstanding 27 lb uplift at joint 1 and 22 lb uplift at joint 4.
- This truss is designed in accordance with the 2015 International Residential Code sections R502.11.1 and R802.10.2 and referenced standard ANSI/TPI 1.
- Graphical purlin representation does not depict the size or the orientation of the purlin along the top and/or bottom chord.

**LOAD CASE(S)** Standard

- Dead + Snow (balanced): Lumber Increase=1.15, Plate Increase=1.00  
Uniform Loads (lb/ft)  
Vert: 1-2=-57, 2-3=-60, 4-6=-20



Job ELV B CP 3CG	Truss P04	Truss Type Monopitch	Qty 2	Ply 1	Chesapeake Homes 628 Roof Job Reference (optional)	161390517
---------------------	--------------	-------------------------	----------	----------	---	-----------

Builders FirstSource (Apex, NC), Apex, NC - 27523,

Run: 8.63 S Aug 30 2023 Print: 8.630 S Aug 30 2023 MiTek Industries, Inc. Thu Oct 12 18:28:20  
ID:3Ap?JDGLaUK7G\_D2E4krwQzIBJ0-RfC?PsB70Hq3NSgPqnL8w3ulTXbGKWRCdoi7J4zJC?f

Page: 1

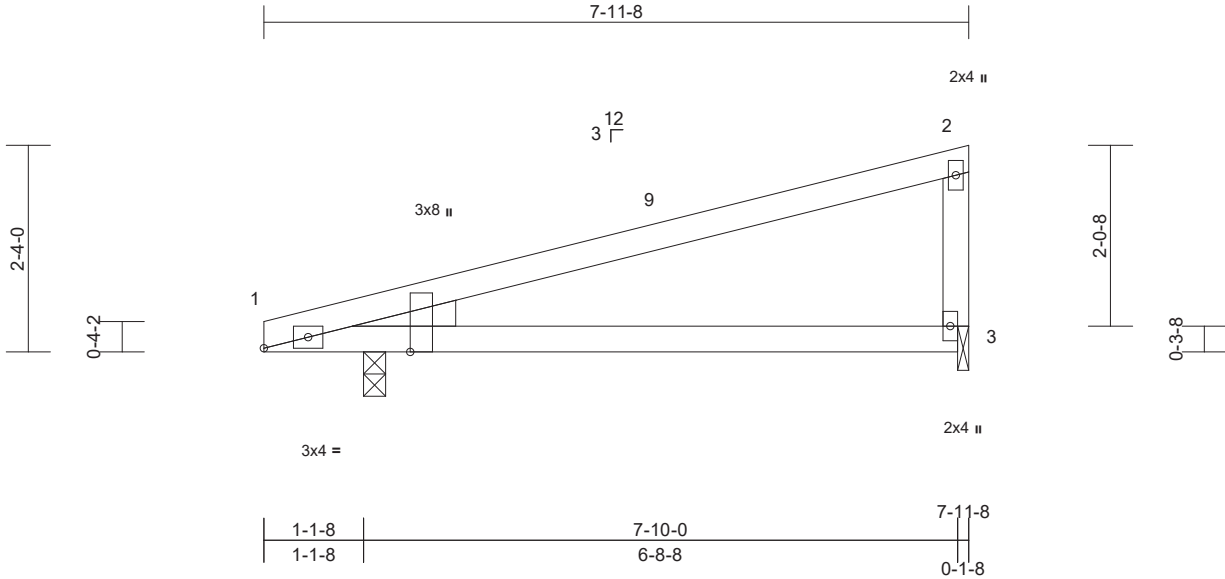

Scale = 1:26

Plate Offsets (X, Y): [1:0-4-0,Edge], [1:0-0-8,Edge]

Loading	(psf)	Spacing	2-0-0	CSI	DEFL	in	(loc)	l/defl	L/d	PLATES	GRIP	
TCLL (roof)	20.0	Plate Grip DOL	1.00	TC	0.70	Vert(LL)	-0.10	3-8	>966	240	MT20	244/190
Snow (Ps/Pf)	18.7/20.0	Lumber DOL	1.15	BC	0.55	Vert(CT)	-0.21	3-8	>451	180		
TCDL	10.0	Rep Stress Incr	YES	WB	0.00	Horz(CT)	0.01	1	n/a	n/a		
BCLL	0.0*	Code	IRC2015/TPI2014	Matrix-MP								
BCDL	10.0											
											Weight: 28 lb	FT = 20%

#### LUMBER

TOP CHORD 2x4 SP No.2  
BOT CHORD 2x4 SP No.2  
WEBS 2x4 SP No.3  
WEDGE Left: 2x4 SP No.3

#### BRACING

TOP CHORD Structural wood sheathing directly applied or 6-0-0 oc purlins, except end verticals.  
BOT CHORD Rigid ceiling directly applied or 10-0-0 oc bracing.

**REACTIONS** (size) 1=0-3-0, 3=0-1-8  
Max Horiz 1=63 (LC 15)  
Max Uplift 1=-24 (LC 12), 3=-25 (LC 16)  
Max Grav 1=365 (LC 2), 3=279 (LC 23)

#### FORCES

(lb) - Maximum Compression/Maximum Tension  
TOP CHORD 1-2=-89/45, 2-3=-190/87  
BOT CHORD 1-3=-91/109

#### NOTES

- 1) Wind: ASCE 7-10; Vult=115mph (3-second gust)  
Vasd=91mph; TCDL=6.0psf; BCDL=6.0psf; h=30ft; Cat. II; Exp B; Enclosed; MWFRS (envelope) exterior zone and C-C Exterior (2) zone; cantilever left and right exposed; end vertical left and right exposed; C-C for members and forces & MWFRS for reactions shown; Lumber DOL=1.60 plate grip DOL=1.33
- 2) TCLL: ASCE 7-10; Pr=20.0 psf (roof live load: Lumber DOL=1.15 Plate DOL=1.00); Pf=20.0 psf (flat roof snow); Ps=18.7 psf (roof snow: Lumber DOL=1.15 Plate DOL=1.00); Category II; Exp B; Fully Exp.; Ct=1.10; Unobstructed slippery surface
- 3) Roof design snow load has been reduced to account for slope.
- 4) Unbalanced snow loads have been considered for this design.
- 5) This truss has been designed for a 10.0 psf bottom chord live load nonconcurrent with any other live loads.

- 6) \* This truss has been designed for a live load of 20.0psf on the bottom chord in all areas where a rectangle 3-06-00 tall by 2-00-00 wide will fit between the bottom chord and any other members.
- 7) Bearings are assumed to be: Joint 1 SP No.2 crushing capacity of 565 psi, Joint 3 SP No.3 crushing capacity of 565 psi.
- 8) Bearing at joint(s) 3 considers parallel to grain value using ANSI/TPI 1 angle to grain formula. Building designer should verify capacity of bearing surface.
- 9) Provide mechanical connection (by others) of truss to bearing plate at joint(s) 3.
- 10) Provide mechanical connection (by others) of truss to bearing plate capable of withstanding 24 lb uplift at joint 1 and 25 lb uplift at joint 3.
- 11) This truss is designed in accordance with the 2015 International Residential Code sections R502.11.1 and R802.10.2 and referenced standard ANSI/TPI 1.

**LOAD CASE(S)** Standard



October 16, 2023

**WARNING - Verify design parameters and READ NOTES ON THIS AND INCLUDED MITEK REFERENCE PAGE MII-7473 rev. 1/2/2023 BEFORE USE.**

Design valid for use only with MiTek® connectors. This design is based only upon parameters shown, and is for an individual building component, not a truss system. Before use, the building designer must verify the applicability of design parameters and properly incorporate this design into the overall building design. Bracing indicated is to prevent buckling of individual truss web and/or chord members only. Additional temporary and permanent bracing is always required for stability and to prevent collapse with possible personal injury and property damage. For general guidance regarding the fabrication, storage, delivery, erection and bracing of trusses and truss systems, see **ANSI/TPI1 Quality Criteria and DSB-22** available from Truss Plate Institute (www.tpinst.org) and **BCSI Building Component Safety Information** available from the Structural Building Component Association (www.sbcacomponents.com)

ENGINEERING BY  
**TRENCO**  
A MiTek Affiliate

818 Soundside Road  
Edenton, NC 27932

Job ELV B CP 3CG	Truss V01	Truss Type Valley	Qty 1	Ply 1	Chesapeake Homes 628 Roof Job Reference (optional)	161390518
---------------------	--------------	----------------------	----------	----------	---	-----------

Builders FirstSource (Apex, NC), Apex, NC - 27523,

Run: 8.63 S Aug 30 2023 Print: 8.630 S Aug 30 2023 MiTek Industries, Inc. Thu Oct 12 18:28:20  
ID:E0Zd81oG80YGhiU5uFJBDzIBZ6-RfC?PsB70Hq3NSgPqnL8w3uITXbGKWrCDoi7J4zJC7f

Page: 1

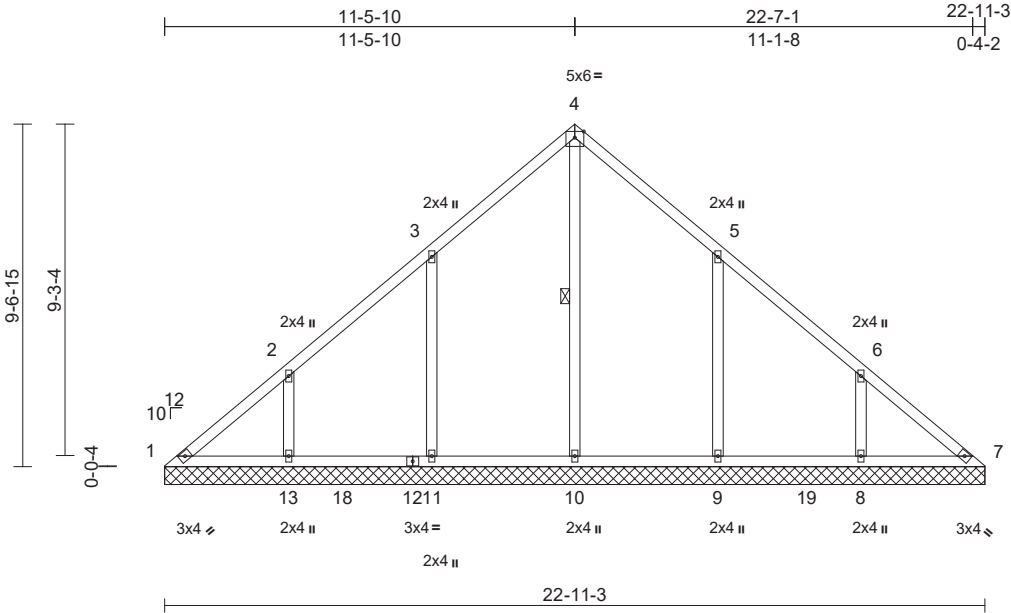

Loading	(psf)	Spacing	2-0-0	CSI	DEFL	in	(loc)	l/defl	L/d	PLATES	GRIP	
TCLL (roof)	20.0	Plate Grip DOL	1.00	TC	0.21	Vert(LL)	n/a	-	n/a	999	MT20	244/190
Snow (Ps/Pf)	10.1/20.0	Lumber DOL	1.15	BC	0.16	Vert(TL)	n/a	-	n/a	999		
TCDL	10.0	Rep Stress Incr	YES	WB	0.18	Horiz(TL)	0.01	7	n/a	n/a		
BCLL	0.0*	Code	IRC2015/TPI2014	Matrix-MS								
BCDL	10.0											
											Weight: 114 lb	FT = 20%

**LUMBER**

TOP CHORD 2x4 SP No.2  
BOT CHORD 2x4 SP No.2  
OTHERS 2x4 SP No.3

**BRACING**

TOP CHORD Structural wood sheathing directly applied or 6-0-0 oc purlins.  
BOT CHORD Rigid ceiling directly applied or 6-0-0 oc bracing.  
WEBS 1 Row at midpt 4-10

**REACTIONS** (size) 1=22-11-3, 7=22-11-3, 8=22-11-3, 9=22-11-3, 10=22-11-3, 11=22-11-3, 13=22-11-3  
Max Horiz 1=-182 (LC 10)  
Max Uplift 1=-33 (LC 10), 8=-91 (LC 15), 9=-123 (LC 15), 11=-123 (LC 14), 13=-95 (LC 14)  
Max Grav 1=145 (LC 26), 7=118 (LC 28), 8=356 (LC 26), 9=472 (LC 26), 10=423 (LC 28), 11=471 (LC 25), 13=360 (LC 25)

**FORCES** (lb) - Maximum Compression/Maximum Tension  
TOP CHORD 1-2=-182/167, 2-3=-136/133, 3-4=-135/161, 4-5=-135/153, 5-6=-92/89, 6-7=-156/122  
BOT CHORD 1-13=-104/148, 11-13=-104/144, 10-11=-104/144, 9-10=-104/144, 8-9=-104/144, 7-8=-104/144  
WEBS 4-10=-221/0, 3-11=-277/173, 2-13=-239/136, 5-9=-277/173, 6-8=-237/134

- Wind: ASCE 7-10; Vult=115mph (3-second gust) Vasd=91mph; TCDL=6.0psf; BCDL=6.0psf; h=30ft; Cat. II; Exp B; Enclosed; MWFRS (envelope) exterior zone and C-C Exterior (2) zone; cantilever left and right exposed; end vertical left and right exposed; C-C for members and forces & MWFRS for reactions shown; Lumber DOL=1.60 plate grip DOL=1.33
- Truss designed for wind loads in the plane of the truss only. For studs exposed to wind (normal to the face), see Standard Industry Gable End Details as applicable, or consult qualified building designer as per ANSI/TPI 1.
- TCLL: ASCE 7-10; Pr=20.0 psf (roof live load; Lumber DOL=1.15 Plate DOL=1.00); Pf=20.0 psf (flat roof snow); Ps=10.1 psf (roof snow; Lumber DOL=1.15 Plate DOL=1.00); Category II; Exp B; Fully Exp.; Ct=1.10; Unobstructed slippery surface
- Roof design snow load has been reduced to account for slope.
- Gable requires continuous bottom chord bearing.
- Gable studs spaced at 4-0-0 oc.
- This truss has been designed for a 10.0 psf bottom chord live load nonconcurrent with any other live loads.
- \* This truss has been designed for a live load of 20.0psf on the bottom chord in all areas where a rectangle 3-06-00 tall by 2-00-00 wide will fit between the bottom chord and any other members, with BCDL = 10.0psf.
- All bearings are assumed to be SP No.2 crushing capacity of 565 psi.
- Provide mechanical connection (by others) of truss to bearing plate capable of withstanding 33 lb uplift at joint 1, 123 lb uplift at joint 11, 95 lb uplift at joint 13, 123 lb uplift at joint 9 and 91 lb uplift at joint 8.
- This truss is designed in accordance with the 2015 International Residential Code sections R502.11.1 and R802.10.2 and referenced standard ANSI/TPI 1.

LOAD CASE(S) Standard



October 16, 2023

**WARNING - Verify design parameters and READ NOTES ON THIS AND INCLUDED MITEK REFERENCE PAGE MII-7473 rev. 1/2/2023 BEFORE USE.**

Design valid for use only with MiTek® connectors. This design is based only upon parameters shown, and is for an individual building component, not a truss system. Before use, the building designer must verify the applicability of design parameters and properly incorporate this design into the overall building design. Bracing indicated is to prevent buckling of individual truss web and/or chord members only. Additional temporary and permanent bracing is always required for stability and to prevent collapse with possible personal injury and property damage. For general guidance regarding the fabrication, storage, delivery, erection and bracing of trusses and truss systems, see **ANSI/TPI1 Quality Criteria and DSB-22** available from Truss Plate Institute (www.tpinst.org) and **BCSI Building Component Safety Information** available from the Structural Building Component Association (www.sbcacomponents.com)

ENGINEERING BY  
**TRENCO**  
A MiTek Affiliate

818 Soundside Road  
Edenton, NC 27932

Job ELV B CP 3CG	Truss V02	Truss Type Valley	Qty 1	Ply 1	Chesapeake Homes 628 Roof Job Reference (optional)	161390519
---------------------	--------------	----------------------	----------	----------	---	-----------

Builders FirstSource (Apex, NC), Apex, NC - 27523,

Run: 8.63 S Aug 30 2023 Print: 8.630 S Aug 30 2023 MiTek Industries, Inc. Thu Oct 12 18:28:20  
ID:iC7?LnpuvKg7Js3HSTnYjRzIBZ5-RfC?PsB70Hq3NSgPqnL8w3uITXbGKWwCDoi7J4zJC?f

Page: 1

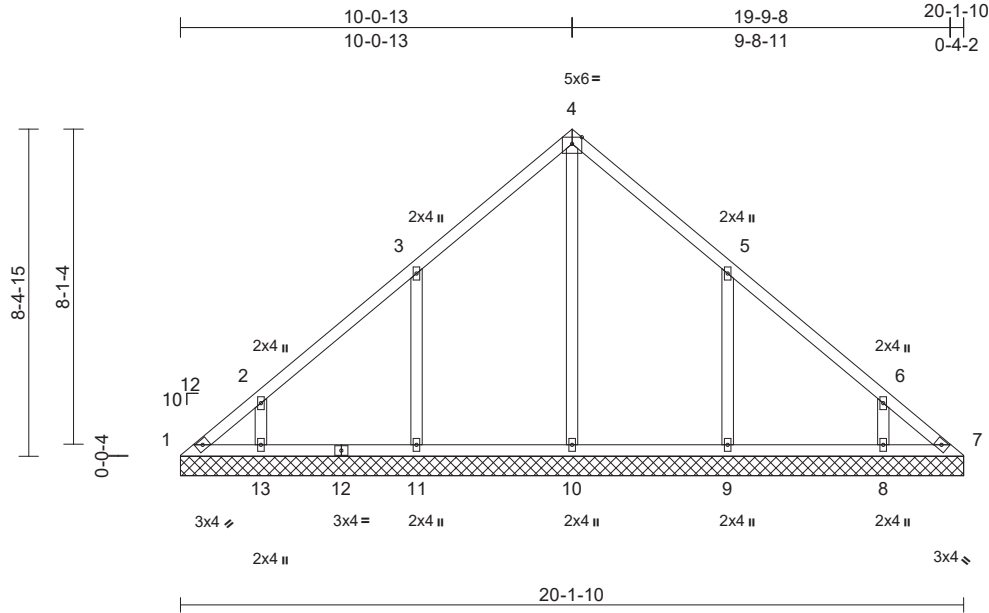

Loading	(psf)	Spacing	2-0-0	CSI	DEFL	in	(loc)	l/defl	L/d	PLATES	GRIP	
TCLL (roof)	20.0	Plate Grip DOL	1.00	TC	0.20	Vert(LL)	n/a	-	n/a	999	MT20	244/190
Snow (Ps/Pf)	10.1/20.0	Lumber DOL	1.15	BC	0.19	Vert(TL)	n/a	-	n/a	999		
TCDL	10.0	Rep Stress Incr	YES	WB	0.22	Horiz(TL)	0.00	7	n/a	n/a		
BCLL	0.0*	Code	IRC2015/TPI2014	Matrix-MS								
BCDL	10.0										Weight: 96 lb	FT = 20%

**LUMBER**  
 TOP CHORD 2x4 SP No.2  
 BOT CHORD 2x4 SP No.2  
 OTHERS 2x4 SP No.3

**BRACING**  
 TOP CHORD Structural wood sheathing directly applied or 6-0-0 oc purlins.  
 BOT CHORD Rigid ceiling directly applied or 10-0-0 oc bracing.

**REACTIONS** (size)  
 1=20-1-10, 7=20-1-10, 8=20-1-10,  
 9=20-1-10, 10=20-1-10,  
 11=20-1-10, 13=20-1-10  
 Max Horiz 1=-159 (LC 10)  
 Max Uplift 1=-42 (LC 10), 7=-4 (LC 11), 8=-66 (LC 15), 9=-126 (LC 15), 11=-126 (LC 14), 13=-71 (LC 14)  
 Max Grav 1=111 (LC 26), 7=90 (LC 28), 8=277 (LC 2), 9=423 (LC 26), 10=389 (LC 28), 11=423 (LC 25), 13=277 (LC 2)

**FORCES** (lb) - Maximum Compression/Maximum Tension  
 TOP CHORD 1-2=-175/131, 2-3=-164/102, 3-4=-154/142, 4-5=-154/137, 5-6=-127/63, 6-7=-140/90  
 BOT CHORD 1-13=-63/123, 11-13=-63/123, 10-11=-63/123, 9-10=-63/123, 8-9=-63/123, 7-8=-63/123  
 WEBS 4-10=-174/4, 3-11=-282/174, 2-13=-216/124, 5-9=-282/174, 6-8=-215/123

**NOTES**  
 1) Unbalanced roof live loads have been considered for this design.

- Wind: ASCE 7-10; Vult=115mph (3-second gust) Vasd=91mph; TCDL=6.0psf; BCDL=6.0psf; h=30ft; Cat. II; Exp B; Enclosed; MWFRS (envelope) exterior zone and C-C Exterior (2) zone; cantilever left and right exposed; end vertical left and right exposed; C-C for members and forces & MWFRS for reactions shown; Lumber DOL=1.60 plate grip DOL=1.33
- Truss designed for wind loads in the plane of the truss only. For studs exposed to wind (normal to the face), see Standard Industry Gable End Details as applicable, or consult qualified building designer as per ANSI/TPI 1.
- TCLL: ASCE 7-10; Pr=20.0 psf (roof live load; Lumber DOL=1.15 Plate DOL=1.00); Pf=20.0 psf (flat roof snow); Ps=10.1 psf (roof snow; Lumber DOL=1.15 Plate DOL=1.00); Category II; Exp B; Fully Exp.; Ct=1.10; Unobstructed slippery surface
- Roof design snow load has been reduced to account for slope.
- Gable requires continuous bottom chord bearing.
- Gable studs spaced at 4-0-0 oc.
- This truss has been designed for a 10.0 psf bottom chord live load nonconcurrent with any other live loads.
- \* This truss has been designed for a live load of 20.0psf on the bottom chord in all areas where a rectangle 3-06-00 tall by 2-00-00 wide will fit between the bottom chord and any other members, with BCDL = 10.0psf.
- All bearings are assumed to be SP No.2 crushing capacity of 565 psi.
- Provide mechanical connection (by others) of truss to bearing plate capable of withstanding 42 lb uplift at joint 1, 4 lb uplift at joint 7, 126 lb uplift at joint 11, 71 lb uplift at joint 13, 126 lb uplift at joint 9 and 66 lb uplift at joint 8.
- This truss is designed in accordance with the 2015 International Residential Code sections R502.11.1 and R802.10.2 and referenced standard ANSI/TPI 1.

**LOAD CASE(S)** Standard



October 16, 2023

**WARNING - Verify design parameters and READ NOTES ON THIS AND INCLUDED MITEK REFERENCE PAGE MII-7473 rev. 1/2/2023 BEFORE USE.**

Design valid for use only with MiTek® connectors. This design is based only upon parameters shown, and is for an individual building component, not a truss system. Before use, the building designer must verify the applicability of design parameters and properly incorporate this design into the overall building design. Bracing indicated is to prevent buckling of individual truss web and/or chord members only. Additional temporary and permanent bracing is always required for stability and to prevent collapse with possible personal injury and property damage. For general guidance regarding the fabrication, storage, delivery, erection and bracing of trusses and truss systems, see **ANSI/TPI1 Quality Criteria and DSB-22** available from Truss Plate Institute (www.tpinst.org) and **BCSI Building Component Safety Information** available from the Structural Building Component Association (www.sbccomponents.com)

ENGINEERING BY  
**TRENCO**  
 A MITEK Affiliate

818 Soundside Road  
 Edenton, NC 27932

Job ELV B CP 3CG	Truss V03	Truss Type Valley	Qty 1	Ply 1	Chesapeake Homes 628 Roof Job Reference (optional)	161390520
---------------------	--------------	----------------------	----------	----------	---	-----------

Builders FirstSource (Apex, NC), Apex, NC - 27523,

Run: 8.63 S Aug 30 2023 Print: 8.630 S Aug 30 2023 MiTek Industries, Inc. Thu Oct 12 18:28:21  
ID:n\_DfTBQyMVZ6OSi2lcAz9hzlBX?-RfC?PsB70Hq3NSgPqnL8w3uITXbGKWrCDoi7J4zJC?f

Page: 1

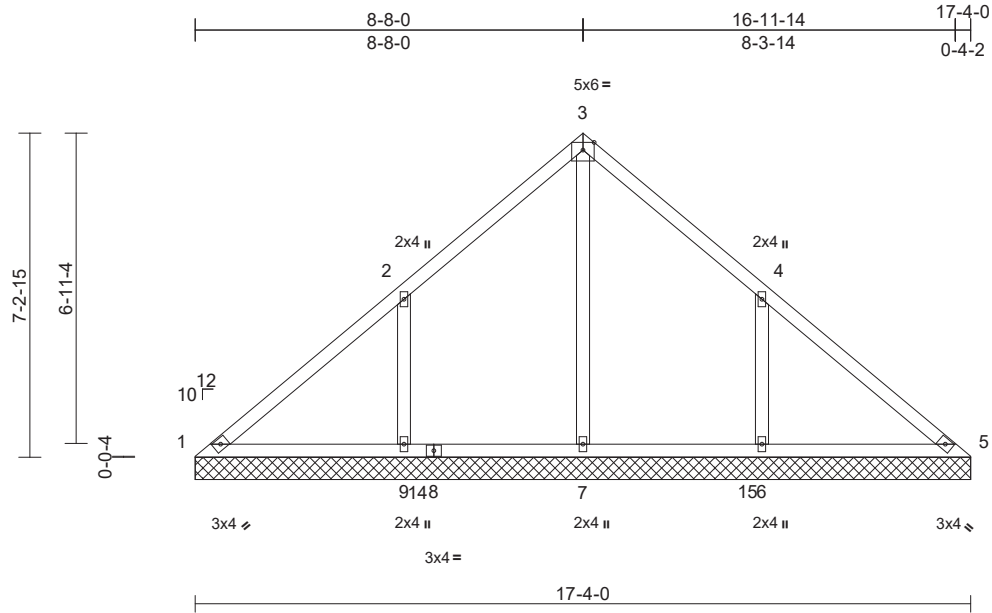

Loading	(psf)	Spacing	2-0-0	CSI	DEFL	in	(loc)	l/defl	L/d	PLATES	GRIP	
TCLL (roof)	20.0	Plate Grip DOL	1.00	TC	0.28	Vert(LL)	n/a	-	n/a	999	MT20	244/190
Snow (Ps/Pf)	10.1/20.0	Lumber DOL	1.15	BC	0.18	Vert(TL)	n/a	-	n/a	999		
TCDL	10.0	Rep Stress Incr	YES	WB	0.30	Horiz(TL)	0.00	5	n/a	n/a		
BCLL	0.0*	Code	IRC2015/TPI2014	Matrix-MS								
BCDL	10.0											
											Weight: 78 lb	FT = 20%

**LUMBER**

TOP CHORD 2x4 SP No.2  
BOT CHORD 2x4 SP No.2  
OTHERS 2x4 SP No.3

**BRACING**

TOP CHORD Structural wood sheathing directly applied or 10-0-0 oc purlins.  
BOT CHORD Rigid ceiling directly applied or 6-0-0 oc bracing.

**REACTIONS** (size) 1=17-4-0, 5=17-4-0, 6=17-4-0, 7=17-4-0, 9=17-4-0  
Max Horiz 1=-137 (LC 10)  
Max Uplift 1=-14 (LC 10), 6=-134 (LC 15), 9=-137 (LC 14)  
Max Grav 1=111 (LC 26), 5=102 (LC 30), 6=475 (LC 26), 7=488 (LC 25), 9=478 (LC 25)

**FORCES** (lb) - Maximum Compression/Maximum Tension  
TOP CHORD 1-2=-126/230, 2-3=-24/170, 3-4=-13/164, 4-5=-105/194  
BOT CHORD 1-9=-151/116, 7-9=-151/114, 6-7=-151/114, 5-6=-151/114  
WEBS 3-7=-329/0, 2-9=-305/175, 4-6=-304/174

- TCLL: ASCE 7-10; Pr=20.0 psf (roof live load: Lumber DOL=1.15 Plate DOL=1.00); Pf=20.0 psf (flat roof snow); Ps=10.1 psf (roof snow: Lumber DOL=1.15 Plate DOL=1.00); Category II; Exp B; Fully Exp.; Ct=1.10; Unobstructed slippery surface
- Roof design snow load has been reduced to account for slope.
- Gable requires continuous bottom chord bearing.
- Gable studs spaced at 4-0-0 oc.
- This truss has been designed for a 10.0 psf bottom chord live load nonconcurrent with any other live loads.
- \* This truss has been designed for a live load of 20.0psf on the bottom chord in all areas where a rectangle 3-06-00 tall by 2-00-00 wide will fit between the bottom chord and any other members, with BCDL = 10.0psf.
- All bearings are assumed to be SP No.2 crushing capacity of 565 psi.
- Provide mechanical connection (by others) of truss to bearing plate capable of withstanding 14 lb uplift at joint 1, 137 lb uplift at joint 9 and 134 lb uplift at joint 6.
- This truss is designed in accordance with the 2015 International Residential Code sections R502.11.1 and R802.10.2 and referenced standard ANSI/TPI 1.

**LOAD CASE(S)** Standard

- NOTES**
- Unbalanced roof live loads have been considered for this design.
  - Wind: ASCE 7-10; Vult=115mph (3-second gust) Vasd=91mph; TCDL=6.0psf; BCDL=6.0psf; h=30ft; Cat. II; Exp B; Enclosed; MWFRS (envelope) exterior zone and C-C Exterior (2) zone; cantilever left and right exposed; end vertical left and right exposed; C-C for members and forces & MWFRS for reactions shown; Lumber DOL=1.60 plate grip DOL=1.33
  - Truss designed for wind loads in the plane of the truss only. For studs exposed to wind (normal to the face), see Standard Industry Gable End Details as applicable, or consult qualified building designer as per ANSI/TPI 1.



October 16, 2023

**WARNING - Verify design parameters and READ NOTES ON THIS AND INCLUDED MITEK REFERENCE PAGE MII-7473 rev. 1/2/2023 BEFORE USE.**

Design valid for use only with MiTek® connectors. This design is based only upon parameters shown, and is for an individual building component, not a truss system. Before use, the building designer must verify the applicability of design parameters and properly incorporate this design into the overall building design. Bracing indicated is to prevent buckling of individual truss web and/or chord members only. Additional temporary and permanent bracing is always required for stability and to prevent collapse with possible personal injury and property damage. For general guidance regarding the fabrication, storage, delivery, erection and bracing of trusses and truss systems, see **ANSI/TPI1 Quality Criteria and DSB-22** available from Truss Plate Institute (www.tpinst.org) and **BCSI Building Component Safety Information** available from the Structural Building Component Association (www.sbcacomponents.com)

ENGINEERING BY  
**TRENCO**  
A MiTek Affiliate

818 Soundside Road  
Edenton, NC 27932



Job ELV B CP 3CG	Truss V04	Truss Type Valley	Qty 1	Ply 1	Chesapeake Homes 628 Roof Job Reference (optional)	161390521
---------------------	--------------	----------------------	----------	----------	---	-----------

Builders FirstSource (Apex, NC), Apex, NC - 27523,

Run: 8.63 S Aug 30 2023 Print: 8.630 S Aug 30 2023 MiTek Industries, Inc. Thu Oct 12 18:28:21  
ID:FAan1hXRa6ohz?btEsJiChvzIBX\_-rFC?PsB70Hq3NSgPqnL8w3uITXbGKWrCDoi7J4zJC?

Page: 1

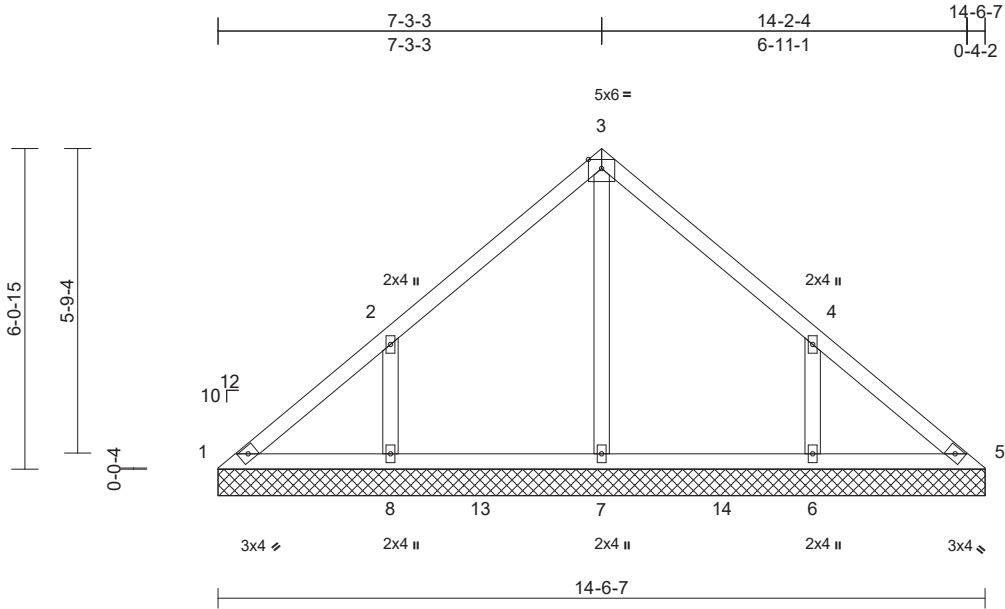

Loading	(psf)	Spacing	2-0-0	CSI	DEFL	in	(loc)	l/defl	L/d	PLATES	GRIP	
TCLL (roof)	20.0	Plate Grip DOL	1.00	TC	0.20	Vert(LL)	n/a	-	n/a	999	MT20	244/190
Snow (Ps/Pf)	10.1/20.0	Lumber DOL	1.15	BC	0.15	Vert(TL)	n/a	-	n/a	999		
TCDL	10.0	Rep Stress Incr	YES	WB	0.14	Horiz(TL)	0.00	5	n/a	n/a		
BCLL	0.0*	Code	IRC2015/TPI2014	Matrix-MS								
BCDL	10.0											
											Weight: 63 lb	FT = 20%

**LUMBER**

TOP CHORD 2x4 SP No.2  
BOT CHORD 2x4 SP No.2  
OTHERS 2x4 SP No.3

**BRACING**

TOP CHORD Structural wood sheathing directly applied or 6-0-0 oc purlins.  
BOT CHORD Rigid ceiling directly applied or 6-0-0 oc bracing.

**REACTIONS** (size) 1=14-6-7, 5=14-6-7, 6=14-6-7, 7=14-6-7, 8=14-6-7  
Max Horiz 1=-114 (LC 10)  
Max Uplift 1=-15 (LC 10), 6=-111 (LC 15), 8=-113 (LC 14)  
Max Grav 1=113 (LC 26), 5=95 (LC 2), 6=369 (LC 26), 7=386 (LC 25), 8=372 (LC 25)

**FORCES** (lb) - Maximum Compression/Maximum Tension  
TOP CHORD 1-2=-136/121, 2-3=-101/102, 3-4=-84/90, 4-5=-111/92  
BOT CHORD 1-8=-65/113, 7-8=-65/83, 6-7=-65/83, 5-6=-65/86  
WEBS 3-7=-219/0, 2-8=-263/153, 4-6=-261/152

- TCLL: ASCE 7-10; Pr=20.0 psf (roof live load: Lumber DOL=1.15 Plate DOL=1.00); Pf=20.0 psf (flat roof snow); Ps=10.1 psf (roof snow: Lumber DOL=1.15 Plate DOL=1.00); Category II; Exp B; Fully Exp.; Ct=1.10; Unobstructed slippery surface
- Roof design snow load has been reduced to account for slope.
- Gable requires continuous bottom chord bearing.
- Gable studs spaced at 4-0-0 oc.
- This truss has been designed for a 10.0 psf bottom chord live load nonconcurrent with any other live loads.
- \* This truss has been designed for a live load of 20.0psf on the bottom chord in all areas where a rectangle 3-06-00 tall by 2-00-00 wide will fit between the bottom chord and any other members, with BCDL = 10.0psf.
- All bearings are assumed to be SP No.2 crushing capacity of 565 psi.
- Provide mechanical connection (by others) of truss to bearing plate capable of withstanding 15 lb uplift at joint 1, 113 lb uplift at joint 8 and 111 lb uplift at joint 6.
- This truss is designed in accordance with the 2015 International Residential Code sections R502.11.1 and R802.10.2 and referenced standard ANSI/TPI 1.

**LOAD CASE(S)** Standard

**NOTES**

- Unbalanced roof live loads have been considered for this design.
- Wind: ASCE 7-10; Vult=115mph (3-second gust) Vasd=91mph; TCDL=6.0psf; BCDL=6.0psf; h=30ft; Cat. II; Exp B; Enclosed; MWFRS (envelope) exterior zone and C-C Exterior (2) zone; cantilever left and right exposed; end vertical left and right exposed; C-C for members and forces & MWFRS for reactions shown; Lumber DOL=1.60 plate grip DOL=1.33
- Truss designed for wind loads in the plane of the truss only. For studs exposed to wind (normal to the face), see Standard Industry Gable End Details as applicable, or consult qualified building designer as per ANSI/TPI 1.

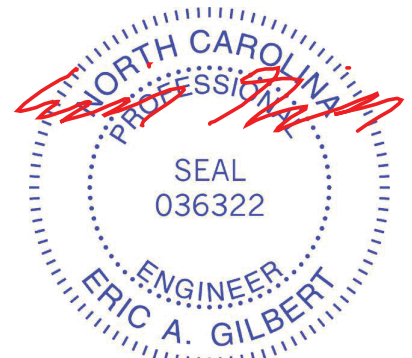

October 16, 2023

**WARNING - Verify design parameters and READ NOTES ON THIS AND INCLUDED MITEK REFERENCE PAGE MII-7473 rev. 1/2/2023 BEFORE USE.**

Design valid for use only with MiTek® connectors. This design is based only upon parameters shown, and is for an individual building component, not a truss system. Before use, the building designer must verify the applicability of design parameters and properly incorporate this design into the overall building design. Bracing indicated is to prevent buckling of individual truss web and/or chord members only. Additional temporary and permanent bracing is always required for stability and to prevent collapse with possible personal injury and property damage. For general guidance regarding the fabrication, storage, delivery, erection and bracing of trusses and truss systems, see **ANSI/TPI1 Quality Criteria and DSB-22** available from Truss Plate Institute (www.tpinst.org) and **BCSI Building Component Safety Information** available from the Structural Building Component Association (www.sbcacomponents.com)



818 Soundside Road  
Edenton, NC 27932

Job ELV B CP 3CG	Truss V05	Truss Type Valley	Qty 1	Ply 1	Chesapeake Homes 628 Roof Job Reference (optional)	161390522
---------------------	--------------	----------------------	----------	----------	---	-----------

Builders FirstSource (Apex, NC), Apex, NC - 27523,

Run: 8.63 S Aug 30 2023 Print: 8.630 S Aug 30 2023 MiTek Industries, Inc. Thu Oct 12 18:28:21  
ID:FAAn1hXRa6ohz?btEsJiChvzIBX\_-rFC?PsB70Hq3NSgPqnL8w3uITXbGKWRcDoi7J4zJC?f

Page: 1

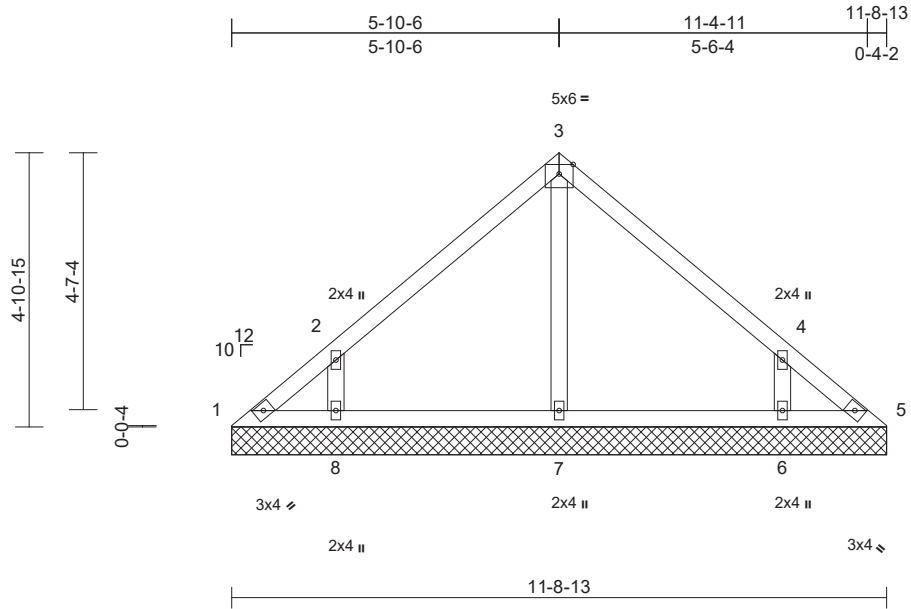

Scale = 1:41.3

Loading	(psf)	Spacing	2-0-0	CSI	DEFL	in	(loc)	l/defl	L/d	PLATES	GRIP	
TCLL (roof)	20.0	Plate Grip DOL	1.00	TC	0.18	Vert(LL)	n/a	-	n/a	999	MT20	244/190
Snow (Ps/Pf)	10.1/20.0	Lumber DOL	1.15	BC	0.12	Vert(TL)	n/a	-	n/a	999		
TCDL	10.0	Rep Stress Incr	YES	WB	0.06	Horiz(TL)	0.00	5	n/a	n/a		
BCLL	0.0*	Code	IRC2015/TPI2014	Matrix-MS								
BCDL	10.0											
										Weight: 48 lb	FT = 20%	

#### LUMBER

TOP CHORD 2x4 SP No.2  
BOT CHORD 2x4 SP No.2  
OTHERS 2x4 SP No.3

#### BRACING

TOP CHORD Structural wood sheathing directly applied or 6-0-0 oc purlins.  
BOT CHORD Rigid ceiling directly applied or 10-0-0 oc bracing.

#### REACTIONS

(size) 1=11-8-13, 5=11-8-13, 6=11-8-13, 7=11-8-13, 8=11-8-13  
Max Horiz 1=-91 (LC 10)  
Max Uplift 1=-27 (LC 10), 5=-4 (LC 11), 6=-96 (LC 15), 8=-99 (LC 14)  
Max Grav 1=78 (LC 26), 5=61 (LC 25), 6=310 (LC 26), 7=238 (LC 2), 8=313 (LC 25)

#### FORCES

(lb) - Maximum Compression/Maximum Tension

TOP CHORD 1-2=-97/83, 2-3=-142/86, 3-4=-139/82, 4-5=-77/53  
BOT CHORD 1-8=-24/67, 7-8=-21/67, 6-7=-21/67, 5-6=-21/67  
WEBS 3-7=-151/0, 2-8=-261/159, 4-6=-260/158

#### NOTES

- Unbalanced roof live loads have been considered for this design.
- Wind: ASCE 7-10; Vult=115mph (3-second gust) Vasd=91mph; TCDL=6.0psf; BCDL=6.0psf; h=30ft; Cat. II; Exp B; Enclosed; MWFRS (envelope) exterior zone and C-C Exterior (2) zone; cantilever left and right exposed; end vertical left and right exposed; C-C for members and forces & MWFRS for reactions shown; Lumber DOL=1.60 plate grip DOL=1.33
- Truss designed for wind loads in the plane of the truss only. For studs exposed to wind (normal to the face), see Standard Industry Gable End Details as applicable, or consult qualified building designer as per ANSI/TPI 1.

- TCLL: ASCE 7-10; Pr=20.0 psf (roof live load: Lumber DOL=1.15 Plate DOL=1.00); Pf=20.0 psf (flat roof snow); Ps=10.1 psf (roof snow: Lumber DOL=1.15 Plate DOL=1.00); Category II; Exp B; Fully Exp.; Ct=1.10; Unobstructed slippery surface
- Roof design snow load has been reduced to account for slope.
- Gable requires continuous bottom chord bearing.
- Gable studs spaced at 4-0-0 oc.
- This truss has been designed for a 10.0 psf bottom chord live load nonconcurrent with any other live loads.
- \* This truss has been designed for a live load of 20.0psf on the bottom chord in all areas where a rectangle 3-06-00 tall by 2-00-00 wide will fit between the bottom chord and any other members.
- All bearings are assumed to be SP No.2 crushing capacity of 565 psi.
- Provide mechanical connection (by others) of truss to bearing plate capable of withstanding 27 lb uplift at joint 1, 4 lb uplift at joint 5, 99 lb uplift at joint 8 and 96 lb uplift at joint 6.
- This truss is designed in accordance with the 2015 International Residential Code sections R502.11.1 and R802.10.2 and referenced standard ANSI/TPI 1.

LOAD CASE(S) Standard



October 16, 2023

**WARNING - Verify design parameters and READ NOTES ON THIS AND INCLUDED MITEK REFERENCE PAGE MII-7473 rev. 1/2/2023 BEFORE USE.**

Design valid for use only with MiTek® connectors. This design is based only upon parameters shown, and is for an individual building component, not a truss system. Before use, the building designer must verify the applicability of design parameters and properly incorporate this design into the overall building design. Bracing indicated is to prevent buckling of individual truss web and/or chord members only. Additional temporary and permanent bracing is always required for stability and to prevent collapse with possible personal injury and property damage. For general guidance regarding the fabrication, storage, delivery, erection and bracing of trusses and truss systems, see **ANSI/TPI1 Quality Criteria and DSB-22** available from Truss Plate Institute (www.tpinst.org) and **BCSI Building Component Safety Information** available from the Structural Building Component Association (www.sbcacomponents.com)

ENGINEERING BY  
**TRENCO**  
A MITEK AFFILIATE

818 Soundside Road  
Edenton, NC 27932



Job ELV B CP 3CG	Truss V07	Truss Type Valley	Qty 1	Ply 1	Chesapeake Homes 628 Roof Job Reference (optional)	161390524
---------------------	--------------	----------------------	----------	----------	---	-----------

Builders FirstSource (Apex, NC), Apex, NC - 27523,

Run: 8.63 S Aug 30 2023 Print: 8.630 S Aug 30 2023 MiTek Industries, Inc. Thu Oct 12 18:28:22  
ID:Ok\_LxAhg78Sx9nNkZcV2ZQzIBSo-RfC?PsB70Hq3NSgPqnL8w3uITxbGKWrCDoi7J4zJC?F

Page: 1

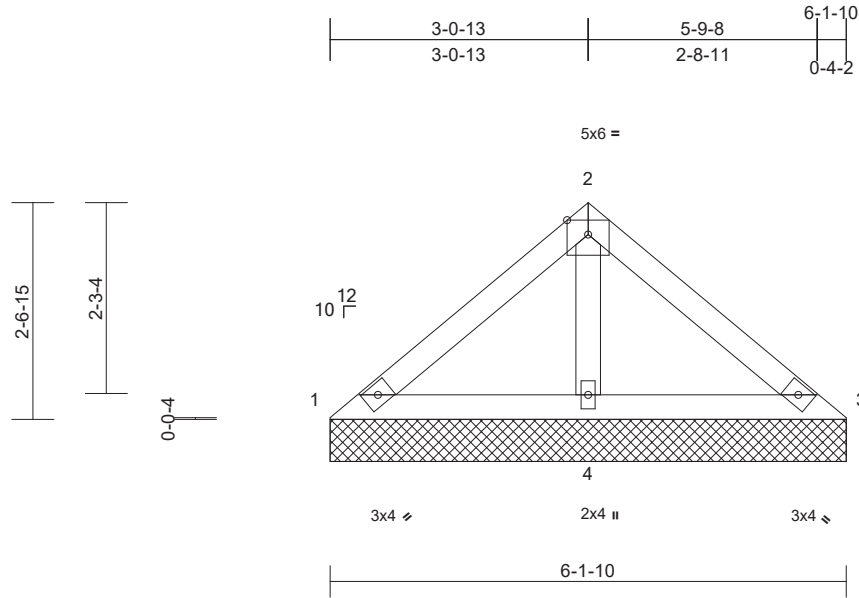

Scale = 1:27.4

Loading	(psf)	Spacing	2-0-0	CSI	DEFL	in	(loc)	l/defl	L/d	PLATES	GRIP	
TCLL (roof)	20.0	Plate Grip DOL	1.00	TC	0.11	Vert(LL)	n/a	-	n/a	999	MT20	244/190
Snow (Ps/Pf)	10.1/20.0	Lumber DOL	1.15	BC	0.12	Vert(TL)	n/a	-	n/a	999		
TCDL	10.0	Rep Stress Incr	YES	WB	0.06	Horiz(TL)	0.00	3	n/a	n/a		
BCLL	0.0*	Code	IRC2015/TPI2014	Matrix-MP								
BCDL	10.0											
										Weight: 22 lb	FT = 20%	

**LUMBER**

TOP CHORD 2x4 SP No.2  
BOT CHORD 2x4 SP No.2  
OTHERS 2x4 SP No.3

**BRACING**

TOP CHORD Structural wood sheathing directly applied or 6-1-10 oc purlins.  
BOT CHORD Rigid ceiling directly applied or 6-0-0 oc bracing.

**REACTIONS**

(size) 1=6-1-10, 3=6-1-10, 4=6-1-10  
Max Horiz 1=-46 (LC 10)  
Max Uplift 4=-22 (LC 14)  
Max Grav 1=66 (LC 29), 3=66 (LC 30), 4=394 (LC 2)

**FORCES**

(lb) - Maximum Compression/Maximum Tension

TOP CHORD 1-2=-57/138, 2-3=-57/138  
BOT CHORD 1-4=-109/64, 3-4=-109/64  
WEBS 2-4=-265/63

**NOTES**

- 1) Unbalanced roof live loads have been considered for this design.
- 2) Wind: ASCE 7-10; Vult=115mph (3-second gust) Vasd=91mph; TCDL=6.0psf; BCDL=6.0psf; h=30ft; Cat. II; Exp B; Enclosed; MWFRS (envelope) exterior zone and C-C Exterior (2) zone; cantilever left and right exposed; end vertical left and right exposed; C-C for members and forces & MWFRS for reactions shown; Lumber DOL=1.60 plate grip DOL=1.33
- 3) Truss designed for wind loads in the plane of the truss only. For studs exposed to wind (normal to the face), see Standard Industry Gable End Details as applicable, or consult qualified building designer as per ANSI/TPI 1.
- 4) TCLL: ASCE 7-10; Pr=20.0 psf (roof live load: Lumber DOL=1.15 Plate DOL=1.00); Pf=20.0 psf (flat roof snow); Ps=10.1 psf (roof snow: Lumber DOL=1.15 Plate DOL=1.00); Category II; Exp B; Fully Exp.; Ct=1.10; Unobstructed slippery surface

- 5) Roof design snow load has been reduced to account for slope.
- 6) Gable requires continuous bottom chord bearing.
- 7) Gable studs spaced at 4-0-0 oc.
- 8) This truss has been designed for a 10.0 psf bottom chord live load nonconcurrent with any other live loads.
- 9) \* This truss has been designed for a live load of 20.0psf on the bottom chord in all areas where a rectangle 3-06-00 tall by 2-00-00 wide will fit between the bottom chord and any other members.
- 10) All bearings are assumed to be SP No.2 crushing capacity of 565 psi.
- 11) Provide mechanical connection (by others) of truss to bearing plate capable of withstanding 22 lb uplift at joint 4.
- 12) This truss is designed in accordance with the 2015 International Residential Code sections R502.11.1 and R802.10.2 and referenced standard ANSI/TPI 1.

**LOAD CASE(S)** Standard



October 16, 2023

**WARNING - Verify design parameters and READ NOTES ON THIS AND INCLUDED MITEK REFERENCE PAGE MII-7473 rev. 1/2/2023 BEFORE USE.**

Design valid for use only with MiTek® connectors. This design is based only upon parameters shown, and is for an individual building component, not a truss system. Before use, the building designer must verify the applicability of design parameters and properly incorporate this design into the overall building design. Bracing indicated is to prevent buckling of individual truss web and/or chord members only. Additional temporary and permanent bracing is always required for stability and to prevent collapse with possible personal injury and property damage. For general guidance regarding the fabrication, storage, delivery, erection and bracing of trusses and truss systems, see **ANSI/TPI1 Quality Criteria and DSB-22** available from Truss Plate Institute (www.tpinst.org) and **BCSI Building Component Safety Information** available from the Structural Building Component Association (www.sbcacomponents.com)



818 Soundside Road  
Edenton, NC 27932

Job ELV B CP 3CG	Truss V08	Truss Type Valley	Qty 1	Ply 1	Chesapeake Homes 628 Roof Job Reference (optional)	I61390525
---------------------	--------------	----------------------	----------	----------	---	-----------

Builders FirstSource (Apex, NC), Apex, NC - 27523,

Run: 8.63 S Aug 30 2023 Print: 8.630 S Aug 30 2023 MiTek Industries, Inc. Thu Oct 12 18:28:22  
ID:h4v?PZm4MIKyVsP4Ta7hLuzlBSh-RfC?PsB70Hq3NSgPqnL8w3uITXbGKWrCDoi7J4zJC?f

Page: 1

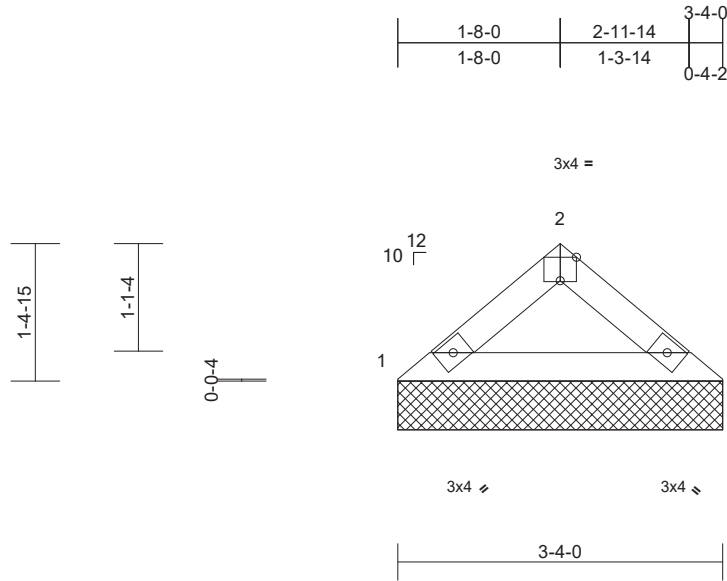

Scale = 1:23.6

Plate Offsets (X, Y): [2:0-2-0,Edge]

Loading	(psf)	Spacing	2-0-0	CSI	DEFL	in	(loc)	l/defl	L/d	PLATES	GRIP	
TCLL (roof)	20.0	Plate Grip DOL	1.00	TC	0.08	Vert(LL)	n/a	-	n/a	999	MT20	244/190
Snow (Ps/Pf)	10.1/20.0	Lumber DOL	1.15	BC	0.07	Vert(TL)	n/a	-	n/a	999		
TCDL	10.0	Rep Stress Incr	YES	WB	0.00	Horiz(TL)	0.00	3	n/a	n/a		
BCLL	0.0*	Code	IRC2015/TPI2014	Matrix-MP								
BCDL	10.0											
										Weight: 10 lb	FT = 20%	

#### LUMBER

TOP CHORD 2x4 SP No.2  
BOT CHORD 2x4 SP No.2

#### BRACING

TOP CHORD Structural wood sheathing directly applied or 3-4-0 oc purlins.  
BOT CHORD Rigid ceiling directly applied or 10-0-0 oc bracing.

#### REACTIONS (size) 1=3-4-0, 3=3-4-0

Max Horiz 1=-24 (LC 12)  
Max Uplift 1=-2 (LC 14), 3=-2 (LC 15)  
Max Grav 1=133 (LC 2), 3=133 (LC 2)

#### FORCES (lb) - Maximum Compression/Maximum Tension

TOP CHORD 1-2=-175/21, 2-3=-175/21  
BOT CHORD 1-3=-10/131

#### NOTES

- Unbalanced roof live loads have been considered for this design.
- Wind: ASCE 7-10; Vult=115mph (3-second gust) Vasd=91mph; TCDL=6.0psf; BCDL=6.0psf; h=30ft; Cat. II; Exp B; Enclosed; MWFRS (envelope) exterior zone and C-C Exterior (2) zone; cantilever left and right exposed; end vertical left and right exposed; C-C for members and forces & MWFRS for reactions shown; Lumber DOL=1.60 plate grip DOL=1.33
- Truss designed for wind loads in the plane of the truss only. For studs exposed to wind (normal to the face), see Standard Industry Gable End Details as applicable, or consult qualified building designer as per ANSI/TPI 1.
- TCLL: ASCE 7-10; Pr=20.0 psf (roof live load: Lumber DOL=1.15 Plate DOL=1.00); Pf=20.0 psf (flat roof snow); Ps=10.1 psf (roof snow: Lumber DOL=1.15 Plate DOL=1.00); Category II; Exp B; Fully Exp.; Ct=1.10; Unobstructed slippery surface
- Roof design snow load has been reduced to account for slope.

- Gable requires continuous bottom chord bearing.
- Gable studs spaced at 4-0-0 oc.
- This truss has been designed for a 10.0 psf bottom chord live load nonconcurrent with any other live loads.
- \* This truss has been designed for a live load of 20.0psf on the bottom chord in all areas where a rectangle 3-06-00 tall by 2-00-00 wide will fit between the bottom chord and any other members.
- All bearings are assumed to be SP No.2 crushing capacity of 565 psi.
- Provide mechanical connection (by others) of truss to bearing plate capable of withstanding 2 lb uplift at joint 1 and 2 lb uplift at joint 3.
- This truss is designed in accordance with the 2015 International Residential Code sections R502.11.1 and R802.10.2 and referenced standard ANSI/TPI 1.

LOAD CASE(S) Standard

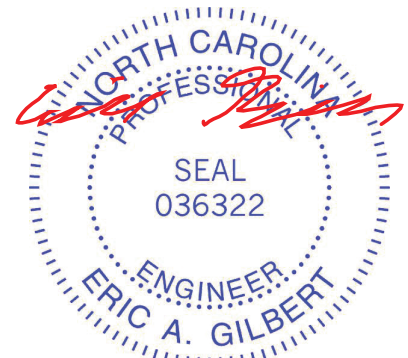

October 16, 2023

#### WARNING - Verify design parameters and READ NOTES ON THIS AND INCLUDED MITEK REFERENCE PAGE MII-7473 rev. 1/2/2023 BEFORE USE.

Design valid for use only with MiTek® connectors. This design is based only upon parameters shown, and is for an individual building component, not a truss system. Before use, the building designer must verify the applicability of design parameters and properly incorporate this design into the overall building design. Bracing indicated is to prevent buckling of individual truss web and/or chord members only. Additional temporary and permanent bracing is always required for stability and to prevent collapse with possible personal injury and property damage. For general guidance regarding the fabrication, storage, delivery, erection and bracing of trusses and truss systems, see ANSI/TPI1 Quality Criteria and DSB-22 available from Truss Plate Institute (www.tpinst.org) and BCSI Building Component Safety Information available from the Structural Building Component Association (www.sbcacomponents.com)



818 Soundside Road  
Edenton, NC 27932

Job ELV B CP 3CG	Truss V09	Truss Type Valley	Qty 1	Ply 1	Chesapeake Homes 628 Roof Job Reference (optional)	161390526
---------------------	--------------	----------------------	----------	----------	---	-----------

Builders FirstSource (Apex, NC), Apex, NC - 27523,

Run: 8.63 S Aug 30 2023 Print: 8.630 S Aug 30 2023 MiTek Industries, Inc. Thu Oct 12 18:28:22  
ID:IDLcbx8o?NLkkozBXklqHszd2BG-RfC?PsB70Hq3NSgPqnL8w3uITXbGKWrCdoi7J4zJC?f

Page: 1

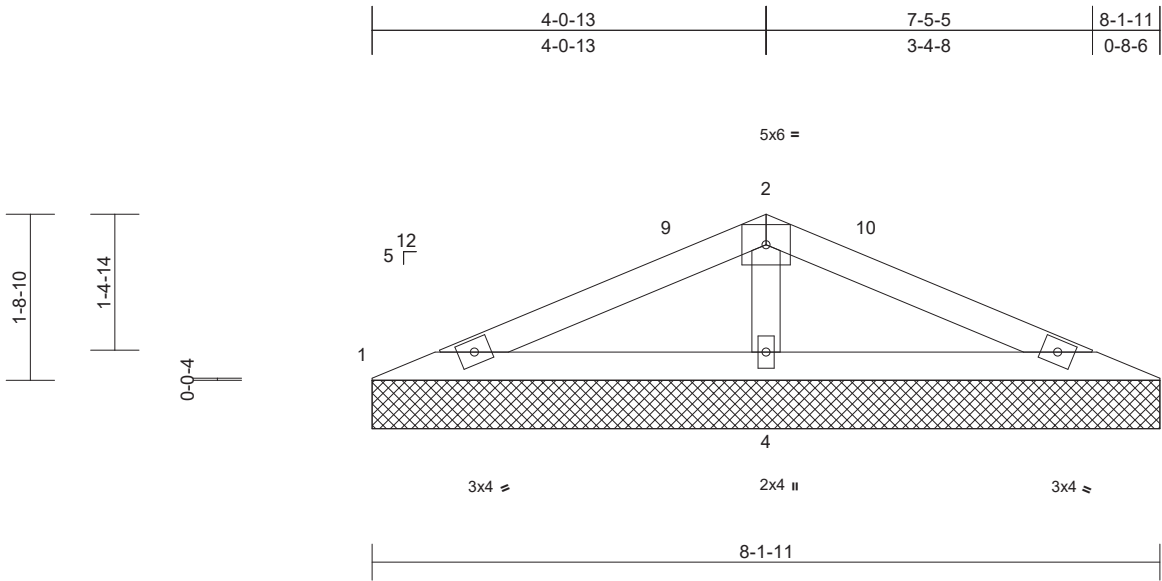

Scale = 1:23.8

Loading	(psf)	Spacing	2-0-0	CSI	DEFL	in	(loc)	l/defl	L/d	PLATES	GRIP	
TCLL (roof)	20.0	Plate Grip DOL	1.00	TC	0.19	Vert(LL)	n/a	-	n/a	999	MT20	244/190
Snow (Ps/Pf)	15.8/20.0	Lumber DOL	1.15	BC	0.20	Vert(TL)	n/a	-	n/a	999		
TCDL	10.0	Rep Stress Incr	YES	WB	0.07	Horiz(TL)	0.00	4	n/a	n/a		
BCLL	0.0*	Code	IRC2015/TPI2014	Matrix-MP								
BCDL	10.0										Weight: 25 lb	FT = 20%

#### LUMBER

TOP CHORD 2x4 SP No.2  
BOT CHORD 2x4 SP No.2  
OTHERS 2x4 SP No.3

#### BRACING

TOP CHORD Structural wood sheathing directly applied or 8-1-11 oc purlins.  
BOT CHORD Rigid ceiling directly applied or 6-0-0 oc bracing.

#### REACTIONS

(size) 1=8-1-11, 3=8-1-11, 4=8-1-11  
Max Horiz 1=20 (LC 16)  
Max Uplift 1=-8 (LC 16), 3=-12 (LC 17), 4=-4 (LC 16)  
Max Grav 1=89 (LC 33), 3=89 (LC 34), 4=523 (LC 2)

#### FORCES

(lb) - Maximum Compression/Maximum Tension

TOP CHORD 1-2=-110/273, 2-3=-110/273  
BOT CHORD 1-4=-229/96, 3-4=-229/96  
WEBS 2-4=-353/111

#### NOTES

- Unbalanced roof live loads have been considered for this design.
- Wind: ASCE 7-10; Vult=115mph (3-second gust) Vasd=91mph; TCDL=6.0psf; BCDL=6.0psf; h=30ft; Cat. II; Exp B; Enclosed; MWFRS (envelope) exterior zone and C-C Exterior (2) zone; cantilever left and right exposed; end vertical left and right exposed; C-C for members and forces & MWFRS for reactions shown; Lumber DOL=1.60 plate grip DOL=1.33
- Truss designed for wind loads in the plane of the truss only. For studs exposed to wind (normal to the face), see Standard Industry Gable End Details as applicable, or consult qualified building designer as per ANSI/TPI 1.

- TCLL: ASCE 7-10; Pr=20.0 psf (roof live load: Lumber DOL=1.15 Plate DOL=1.00); Pf=20.0 psf (flat roof snow); Ps=15.8 psf (roof snow: Lumber DOL=1.15 Plate DOL=1.00); Category II; Exp B; Fully Exp.; Ct=1.10; Unobstructed slippery surface
- Roof design snow load has been reduced to account for slope.
- Unbalanced snow loads have been considered for this design.
- Gable requires continuous bottom chord bearing.
- Gable studs spaced at 4-0-0 oc.
- This truss has been designed for a 10.0 psf bottom chord live load nonconcurrent with any other live loads.
- \* This truss has been designed for a live load of 20.0psf on the bottom chord in all areas where a rectangle 3-06-00 tall by 2-00-00 wide will fit between the bottom chord and any other members.
- All bearings are assumed to be SP No.2 crushing capacity of 565 psi.
- Provide mechanical connection (by others) of truss to bearing plate capable of withstanding 8 lb uplift at joint 1, 12 lb uplift at joint 3 and 4 lb uplift at joint 4.
- This truss is designed in accordance with the 2015 International Residential Code sections R502.11.1 and R802.10.2 and referenced standard ANSI/TPI 1.

LOAD CASE(S) Standard



October 16, 2023

#### WARNING - Verify design parameters and READ NOTES ON THIS AND INCLUDED MITEK REFERENCE PAGE MII-7473 rev. 1/2/2023 BEFORE USE.

Design valid for use only with MiTek® connectors. This design is based only upon parameters shown, and is for an individual building component, not a truss system. Before use, the building designer must verify the applicability of design parameters and properly incorporate this design into the overall building design. Bracing indicated is to prevent buckling of individual truss web and/or chord members only. Additional temporary and permanent bracing is always required for stability and to prevent collapse with possible personal injury and property damage. For general guidance regarding the fabrication, storage, delivery, erection and bracing of trusses and truss systems, see ANSI/TPI1 Quality Criteria and DSB-22 available from Truss Plate Institute (www.tpinst.org) and BCSI Building Component Safety Information available from the Structural Building Component Association (www.sbcacomponents.com)

ENGINEERING BY  
**TRENCO**  
A MITEK Affiliate

818 Soundside Road  
Edenton, NC 27932

Job ELV B CP 3CG	Truss V10	Truss Type Valley	Qty 1	Ply 1	Chesapeake Homes 628 Roof Job Reference (optional)	161390527
---------------------	--------------	----------------------	----------	----------	---	-----------

Builders FirstSource (Apex, NC), Apex, NC - 27523,

Run: 8.63 S Aug 30 2023 Print: 8.630 S Aug 30 2023 MiTek Industries, Inc. Thu Oct 12 18:28:22  
ID:io0kDyAglljJfBimDsrXvUzd2BD-RfC?PsB70Hq3NSgPqnL8w3ulTXbGKWrCdoi7J4zJC?7f

Page: 1

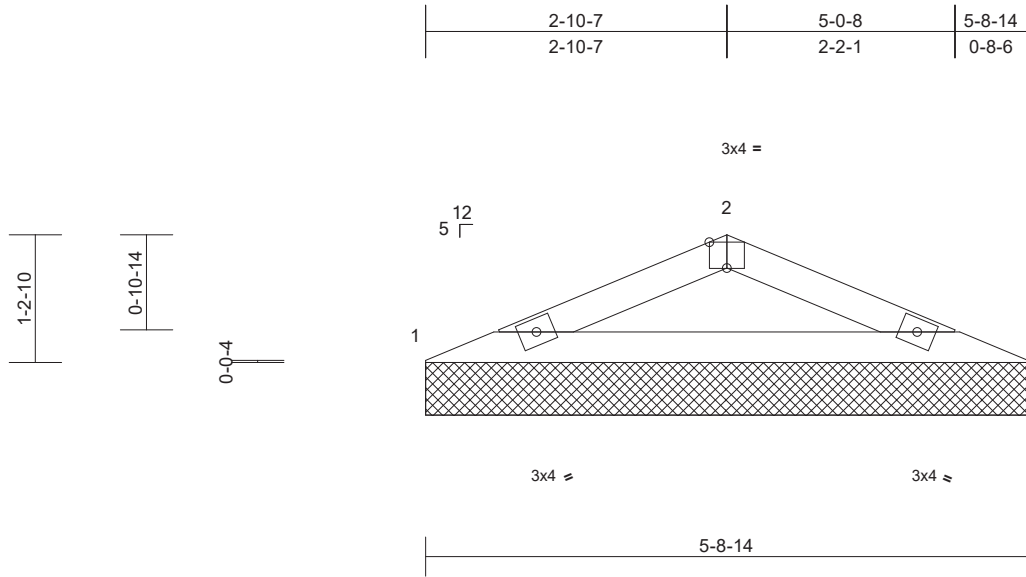

Scale = 1:22  
Plate Offsets (X, Y): [2:0-2-0,Edge]

Loading	(psf)	Spacing	2-0-0	CSI	DEFL	in	(loc)	l/defl	L/d	PLATES	GRIP	
TCLL (roof)	20.0	Plate Grip DOL	1.00	TC	0.26	Vert(LL)	n/a	-	n/a	999	MT20	244/190
Snow (Ps/Pf)	15.8/20.0	Lumber DOL	1.15	BC	0.21	Vert(TL)	n/a	-	n/a	999		
TCDL	10.0	Rep Stress Incr	YES	WB	0.00	Horiz(TL)	0.01	3	n/a	n/a		
BCLL	0.0*	Code	IRC2015/TPI2014	Matrix-MP								
BCDL	10.0										Weight: 16 lb	FT = 20%

**LUMBER**  
TOP CHORD 2x4 SP No.2  
BOT CHORD 2x4 SP No.2

**BRACING**  
TOP CHORD Structural wood sheathing directly applied or 5-8-14 oc purlins.  
BOT CHORD Rigid ceiling directly applied or 10-0-0 oc bracing.

**REACTIONS** (size) 1=5-8-14, 3=5-8-14  
Max Horiz 1=14 (LC 20)  
Max Uplift 1=-7 (LC 16), 3=-7 (LC 17)  
Max Grav 1=230 (LC 2), 3=230 (LC 2)

**FORCES** (lb) - Maximum Compression/Maximum Tension  
TOP CHORD 1-2=-478/124, 2-3=-478/124  
BOT CHORD 1-3=-104/433

- Unbalanced snow loads have been considered for this design.
- Gable requires continuous bottom chord bearing.
- Gable studs spaced at 4-0-0 oc.
- This truss has been designed for a 10.0 psf bottom chord live load nonconcurrent with any other live loads.
- \* This truss has been designed for a live load of 20.0psf on the bottom chord in all areas where a rectangle 3-06-00 tall by 2-00-00 wide will fit between the bottom chord and any other members.
- All bearings are assumed to be SP No.2 crushing capacity of 565 psi.
- Provide mechanical connection (by others) of truss to bearing plate capable of withstanding 7 lb uplift at joint 1 and 7 lb uplift at joint 3.
- This truss is designed in accordance with the 2015 International Residential Code sections R502.11.1 and R802.10.2 and referenced standard ANSI/TPI 1.

**LOAD CASE(S)** Standard

- NOTES**
- Unbalanced roof live loads have been considered for this design.
  - Wind: ASCE 7-10; Vult=115mph (3-second gust) Vasd=91mph; TCDL=6.0psf; BCDL=6.0psf; h=30ft; Cat. II; Exp B; Enclosed; MWFRS (envelope) exterior zone and C-C Exterior (2) zone; cantilever left and right exposed; end vertical left and right exposed; C-C for members and forces & MWFRS for reactions shown; Lumber DOL=1.60 plate grip DOL=1.33
  - Truss designed for wind loads in the plane of the truss only. For studs exposed to wind (normal to the face), see Standard Industry Gable End Details as applicable, or consult qualified building designer as per ANSI/TPI 1.
  - TCLL: ASCE 7-10; Pr=20.0 psf (roof live load: Lumber DOL=1.15 Plate DOL=1.00); Pf=20.0 psf (flat roof snow); Ps=15.8 psf (roof snow: Lumber DOL=1.15 Plate DOL=1.00); Category II; Exp B; Fully Exp.; Ct=1.10; Unobstructed slippery surface
  - Roof design snow load has been reduced to account for slope.



October 16, 2023

**WARNING - Verify design parameters and READ NOTES ON THIS AND INCLUDED MITEK REFERENCE PAGE MII-7473 rev. 1/2/2023 BEFORE USE.**

Design valid for use only with MiTek® connectors. This design is based only upon parameters shown, and is for an individual building component, not a truss system. Before use, the building designer must verify the applicability of design parameters and properly incorporate this design into the overall building design. Bracing indicated is to prevent buckling of individual truss web and/or chord members only. Additional temporary and permanent bracing is always required for stability and to prevent collapse with possible personal injury and property damage. For general guidance regarding the fabrication, storage, delivery, erection and bracing of trusses and truss systems, see **ANSI/TPI1 Quality Criteria and DSB-22** available from Truss Plate Institute ([www.tpinst.org](http://www.tpinst.org)) and **BCSI Building Component Safety Information** available from the Structural Building Component Association ([www.sbcacomponents.com](http://www.sbcacomponents.com))

ENGINEERING BY  
**TRENCO**  
A MiTek Affiliate

818 Soundside Road  
Edenton, NC 27932

Job ELV B CP 3CG	Truss V11	Truss Type Valley	Qty 1	Ply 1	Chesapeake Homes 628 Roof Job Reference (optional)	161390528
---------------------	--------------	----------------------	----------	----------	---	-----------

Builders FirstSource (Apex, NC), Apex, NC - 27523,

Run: 8.63 S Aug 30 2023 Print: 8.630 S Aug 30 2023 MiTek Industries, Inc. Thu Oct 12 18:28:23  
ID:fB8VeeCxqvz1uVs8KHu?\_vzd2BB-RfC?PsB70Hq3NSgPqnL8w3uITXbGKWrCdoi7J4zJC?f

Page: 1

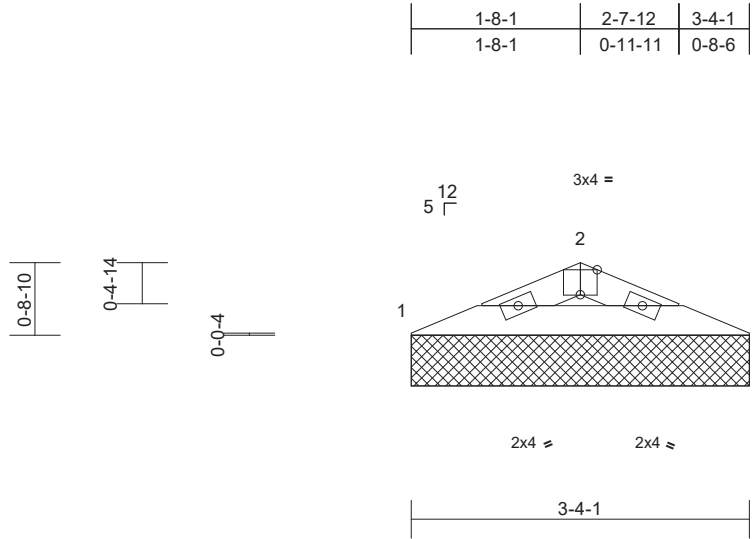

Scale = 1:22.8

Plate Offsets (X, Y): [2:0-2-0,Edge]

Loading	(psf)	Spacing	2-0-0	CSI	DEFL	in	(loc)	l/defl	L/d	PLATES	GRIP	
TCLL (roof)	20.0	Plate Grip DOL	1.00	TC	0.05	Vert(LL)	n/a	-	n/a	999	MT20	244/190
Snow (Ps/Pf)	15.8/20.0	Lumber DOL	1.15	BC	0.10	Vert(TL)	n/a	-	n/a	999		
TCDL	10.0	Rep Stress Incr	YES	WB	0.00	Horiz(TL)	0.00	3	n/a	n/a		
BCLL	0.0*	Code	IRC2015/TPI2014	Matrix-MP								
BCDL	10.0											
										Weight: 8 lb	FT = 20%	

**LUMBER**

TOP CHORD 2x4 SP No.2  
BOT CHORD 2x4 SP No.2

**BRACING**

TOP CHORD Structural wood sheathing directly applied or 3-4-1 oc purlins.  
BOT CHORD Rigid ceiling directly applied or 10-0-0 oc bracing.

**REACTIONS**

(size) 1=3-4-1, 3=3-4-1  
Max Horiz 1=7 (LC 16)  
Max Uplift 1=-4 (LC 16), 3=-4 (LC 17)  
Max Grav 1=134 (LC 2), 3=134 (LC 2)

**FORCES**

(lb) - Maximum Compression/Maximum Tension

TOP CHORD 1-2=-241/65, 2-3=-241/65  
BOT CHORD 1-3=-50/231

**NOTES**

- 1) Unbalanced roof live loads have been considered for this design.
- 2) Wind: ASCE 7-10; Vult=115mph (3-second gust) Vasd=91mph; TCDL=6.0psf; BCDL=6.0psf; h=30ft; Cat. II; Exp B; Enclosed; MWFRS (envelope) exterior zone and C-C Exterior (2) zone; cantilever left and right exposed; end vertical left and right exposed; C-C for members and forces & MWFRS for reactions shown; Lumber DOL=1.60 plate grip DOL=1.33
- 3) Truss designed for wind loads in the plane of the truss only. For studs exposed to wind (normal to the face), see Standard Industry Gable End Details as applicable, or consult qualified building designer as per ANSI/TPI 1.
- 4) TCLL: ASCE 7-10; Pr=20.0 psf (roof live load: Lumber DOL=1.15 Plate DOL=1.00); Pf=20.0 psf (flat roof snow); Ps=15.8 psf (roof snow: Lumber DOL=1.15 Plate DOL=1.00); Category II; Exp B; Fully Exp.; Ct=1.10; Unobstructed slippery surface
- 5) Roof design snow load has been reduced to account for slope.

- 6) Unbalanced snow loads have been considered for this design.
- 7) Gable requires continuous bottom chord bearing.
- 8) Gable studs spaced at 4-0-0 oc.
- 9) This truss has been designed for a 10.0 psf bottom chord live load nonconcurrent with any other live loads.
- 10) \* This truss has been designed for a live load of 20.0psf on the bottom chord in all areas where a rectangle 3-06-00 tall by 2-00-00 wide will fit between the bottom chord and any other members.
- 11) All bearings are assumed to be SP No.2 crushing capacity of 565 psi.
- 12) Provide mechanical connection (by others) of truss to bearing plate capable of withstanding 4 lb uplift at joint 1 and 4 lb uplift at joint 3.
- 13) This truss is designed in accordance with the 2015 International Residential Code sections R502.11.1 and R802.10.2 and referenced standard ANSI/TPI 1.

**LOAD CASE(S)** Standard



October 16, 2023

**WARNING - Verify design parameters and READ NOTES ON THIS AND INCLUDED MITEK REFERENCE PAGE MII-7473 rev. 1/2/2023 BEFORE USE.**

Design valid for use only with MiTek® connectors. This design is based only upon parameters shown, and is for an individual building component, not a truss system. Before use, the building designer must verify the applicability of design parameters and properly incorporate this design into the overall building design. Bracing indicated is to prevent buckling of individual truss web and/or chord members only. Additional temporary and permanent bracing is always required for stability and to prevent collapse with possible personal injury and property damage. For general guidance regarding the fabrication, storage, delivery, erection and bracing of trusses and truss systems, see **ANSI/TPI1 Quality Criteria and DSB-22** available from Truss Plate Institute (www.tpinst.org) and **BCSI Building Component Safety Information** available from the Structural Building Component Association (www.sbcacomponents.com)



818 Soundside Road  
Edenton, NC 27932



# Symbols

## PLATE LOCATION AND ORIENTATION

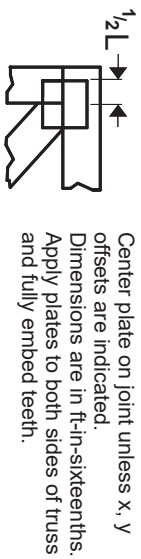

Center plate on joint unless x, y offsets are indicated. Dimensions are in ft-in-sixteenths. Apply plates to both sides of truss and fully embed teeth.

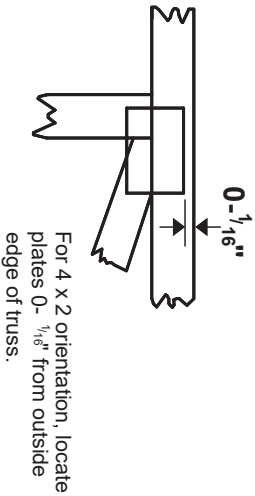

For 4 x 2 orientation, locate plates 0- 1/16\" from outside edge of truss.

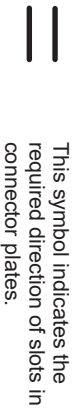

This symbol indicates the required direction of slots in connector plates.

\* Plate location details available in MITek software or upon request.

## PLATE SIZE

**4 X 4**  
The first dimension is the plate width measured perpendicular to slots. Second dimension is the length parallel to slots.

## LATERAL BRACING LOCATION



Indicated by symbol shown and/or by text in the bracing section of the output. Use T or I bracing if indicated.

## BEARING

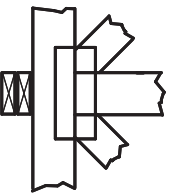

Indicates location where bearings (supports) occur. Icons vary but reaction section indicates joint number/letter where bearings occur. Min size shown is for crushing only.

## Industry Standards:

ANSI/TFP1: National Design Specification for Metal Plate Connected Wood Truss Construction.  
DSB-22: Design Standard for Bracing.  
BCSI: Building Component Safety Information, Guide to Good Practice for Handling, Installing, Restraining & Bracing of Metal Plate Connected Wood Trusses.

# Numbering System

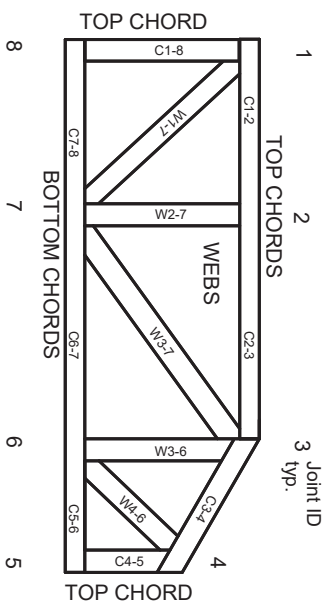

**JOINTS ARE GENERALLY NUMBERED/LETTERED CLOCKWISE AROUND THE TRUSS STARTING AT THE JOINT FARTHEST TO THE LEFT.**

**CHORDS AND WEBS ARE IDENTIFIED BY END JOINT NUMBERS/LETTERS.**

# Product Code Approvals

ICC-ES Reports:  
ESR-1988, ESR-2362, ESR-2685, ESR-3282  
ESR-4722, ESL-1388

# Design General Notes

Trusses are designed for wind loads in the plane of the truss unless otherwise shown.

Lumber design values are in accordance with ANSI/TFP 1 section 6.3. These truss designs rely on Lumber values established by others.

© 2023 MITek® All Rights Reserved

**MITek**

ENGINEERING BY  
**TRENGO**  
A MITek Affiliate

MITek Engineering Reference Sheet: MIL-7473 rev. 1/2/2023

# General Safety Notes

**Failure to Follow Could Cause Property Damage or Personal Injury**

1. Additional stability bracing for truss system, e.g. diagonal or X-bracing, is always required. See BCSI.
2. Truss bracing must be designed by an engineer. For wide truss spacing, individual lateral braces themselves may require bracing, or alternative Tor 1 bracing should be considered.
3. Never exceed the design loading shown and never stack materials on inadequately braced trusses.
4. Provide copies of this truss design to the building designer, erection supervisor, property owner and all other interested parties.
5. Cut members to bear tightly against each other.
6. Place plates on each face of truss at each joint and embed fully. Knots and wane at joint locations are regulated by ANSI/TFP 1.
7. Design assumes trusses will be suitably protected from the environment in accord with ANSI/TFP 1.
8. Unless otherwise noted, moisture content of lumber shall not exceed 19% at time of fabrication.
9. Unless expressly noted, this design is not applicable for use with fire retardant, preservative treated, or green lumber.
10. Camber is a non-structural consideration and is the responsibility of truss fabricator. General practice is to camber for dead load deflection.
11. Plate type, size, orientation and location dimensions indicated are minimum plating requirements.
12. Lumber used shall be of the species and size, and in all respects, equal to or better than that specified.
13. Top chords must be sheathed or purlins provided at spacing indicated on design.
14. Bottom chords require lateral bracing at 10 ft. spacing, or less, if no ceiling is installed, unless otherwise noted.
15. Connections not shown are the responsibility of others.
16. Do not cut or alter truss member or plate without prior approval of an engineer.
17. Install and load vertically unless indicated otherwise.
18. Use of green or treated lumber may pose unacceptable environmental, health or performance risks. Consult with project engineer before use.
19. Review all portions of this design (front, back, words and pictures) before use. Reviewing pictures alone is not sufficient.
20. Design assumes manufacture in accordance with ANSI/TFP 1 Quality Criteria.
21. The design does not take into account any dynamic or other loads other than those expressly stated.