

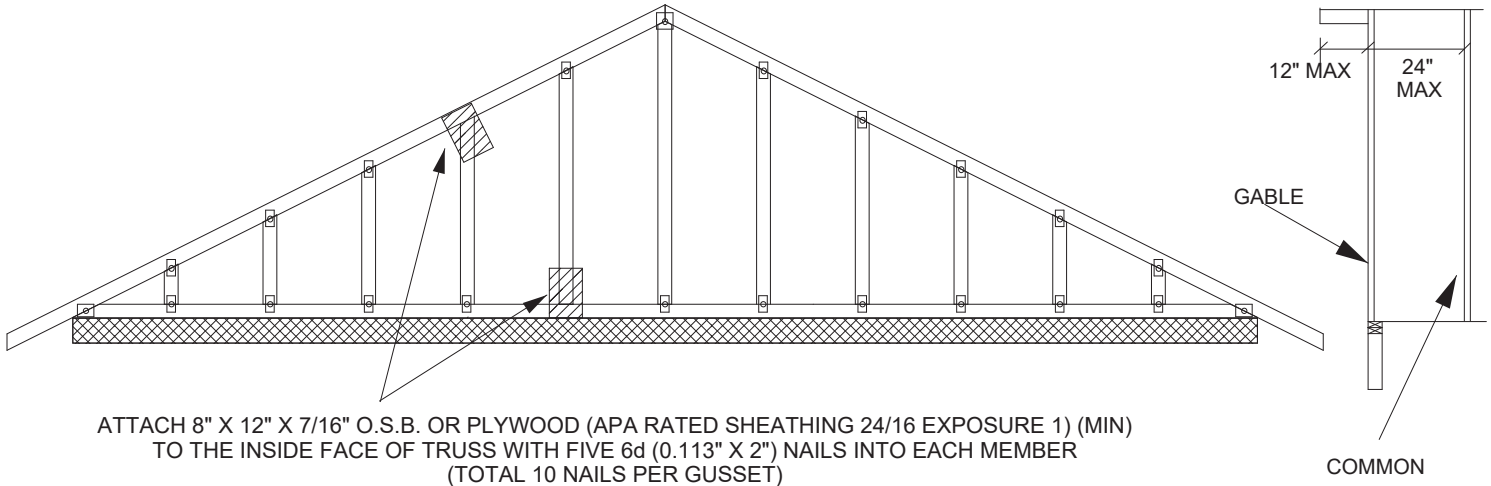

1. THIS IS A SPECIFIC REPAIR DETAIL TO BE USED ONLY FOR ITS ORIGINAL INTENTION. THIS REPAIR DOES NOT IMPLY THAT THE REMAINING PORTION OF THE TRUSS IS UNDAMAGED. THE ENTIRE TRUSS SHALL BE INSPECTED TO VERIFY THAT NO FURTHER REPAIRS ARE REQUIRED. WHEN THE REQUIRED REPAIRS ARE PROPERLY APPLIED, THE TRUSS WILL BE CAPABLE OF SUPPORTING THE LOADS INDICATED.
2. ALL MEMBERS MUST BE RETURNED TO THEIR ORIGINAL POSITIONS BEFORE APPLYING REPAIR AND HELD IN PLACE DURING APPLICATION OF REPAIR.
3. THE END DISTANCE, EDGE DISTANCE, AND SPACING OF NAILS SHALL BE SUCH AS TO AVOID SPLITTING OF THE WOOD.
4. WHEN NAILING SCABS OR GUSSETS, THE USE OF A BACKUP WEIGHT IS RECOMMENDED TO AVOID LOOSENING OF THE CONNECTOR PLATES AT THE JOINTS OR SPLICES.
5. THIS REPAIR IS TO BE USED FOR SINGLE PLY TRUSSES IN THE 2X\_ ORIENTATION ONLY.



ATTACH 8" X 12" X 7/16" O.S.B. OR PLYWOOD (APA RATED SHEATHING 24/16 EXPOSURE 1) (MIN) TO THE INSIDE FACE OF TRUSS WITH FIVE 6d (0.113" X 2") NAILS INTO EACH MEMBER (TOTAL 10 NAILS PER GUSSET)

THE OUTSIDE FACE OF THE GABLE MUST BE SHEATHED WITH (MIN) 7/16" O.S.B OR PLYWOOD. SEE MITEK STANDARD GABLE END DETAILS FOR WIND BRACING REQUIREMENTS.

**TRUSS CRITERIA**

- LOADING : 40-10-0-10 (MAX)
- LOAD DURATION FACTOR : 1.15
- SPACING : 24" O.C. (MAX)
- TOP CHORD : 2X 4 OR 2X 6 (NO 2 MIN)
- PITCH : 3/12 - 12/12
- BEARING : CONTINUOUS
- STUD SPACING :24" O.C. (MAX)

REFER TO INDIVIDUAL TRUSS DESIGN FOR PLATE SIZES AND LUMBER GRADES



January 26, 2024

**WARNING - Verify design parameters and READ NOTES ON THIS AND INCLUDED MITEK REFERENCE PAGE MII-7473 rev. 1/2/2023 BEFORE USE.**  
 Design valid for use only with MiTek® connectors. This design is based only upon parameters shown, and is for an individual building component, not a truss system. Before use, the building designer must verify the applicability of design parameters and properly incorporate this design into the overall building design. Bracing indicated is to prevent buckling of individual truss web and/or chord members only. Additional temporary and permanent bracing is always required for stability and to prevent collapse with possible personal injury and property damage. For general guidance regarding the fabrication, storage, delivery, erection and bracing of trusses and truss systems, see **ANSI/TP1 Quality Criteria and DSB-22** available from Truss Plate Institute ([www.tpinst.org](http://www.tpinst.org)) and **BCSI Building Component Safety Information** available from the Structural Building Component Association ([www.sbcacomponents.com](http://www.sbcacomponents.com))



818 Soundside Road  
 Edenton, NC 27932