

RE: 3894021 - Furr, Mayview B

Trenco
 818 Soundside Rd
 Edenton, NC 27932

Site Information:

Project Customer: Furr Construction Project Name:
 Lot/Block: 1A Subdivision: SHADY GROVE
 Address:
 City: State: NC

Name Address and License # of Structural Engineer of Record, If there is one, for the building.

Name: License #:
 Address:
 City, County: State:

General Truss Engineering Criteria & Design Loads (Individual Truss Design Drawings Show Special Loading Conditions):

Design Code: IRC2015/TPI2014 Design Program: MiTek 20/20 8.6
 Wind Code: ASCE 7-10 Design Method: MWFRS (Envelope)/C-C hybrid Wind ASCE 7-10
 Wind Speed: 130 mph
 Roof Load: 40.0 psf Floor Load: N/A psf

This package includes 13 individual, dated Truss Design Drawings and 0 Additional Drawings.

No.	Seal#	Job ID#	Truss Name	Date
1	163825695	3894021	F01	2/26/24
2	163825696	3894021	F02	2/26/24
3	163825697	3894021	F03	2/26/24
4	163825698	3894021	F04	2/26/24
5	163825699	3894021	F05	2/26/24
6	163825700	3894021	F06	2/26/24
7	163825701	3894021	F07	2/26/24
8	163825702	3894021	F08	2/26/24
9	163825703	3894021	F09	2/26/24
10	163825704	3894021	F10	2/26/24
11	163825705	3894021	F11	2/26/24
12	163825706	3894021	F12	2/26/24
13	163825707	3894021	F13	2/26/24

The truss drawing(s) referenced above have been prepared by Truss Engineering Co. under my direct supervision based on the parameters provided by Builders FirstSource-Sumter,SC.

Truss Design Engineer's Name: Gilbert, Eric
 My license renewal date for the state of North Carolina is December 31, 2024.



IMPORTANT NOTE: The seal on these truss component designs is a certification that the engineer named is licensed in the jurisdiction(s) identified and that the designs comply with ANSI/TPI 1. These designs are based upon parameters shown (e.g., loads, supports, dimensions, shapes and design codes), which were given to MiTek or TRENCO. Any project specific information included is for MiTek's or TRENCO's customers file reference purpose only, and was not taken into account in the preparation of these designs. MiTek or TRENCO has not independently verified the applicability of the design parameters or the designs for any particular building. Before use, the building designer should verify applicability of design parameters and properly incorporate these designs into the overall building design per ANSI/TPI 1, Chapter 2.

February 26, 2024

Gilbert, Eric

Job 3894021	Truss F01	Truss Type Floor Supported Gable	Qty 1	Ply 1	Furr, Mayview B Job Reference (optional)	I63825695
----------------	--------------	-------------------------------------	----------	----------	---------------------------------------------	-----------

Builders FirstSource (Sumter, SC), Sumter, SC - 29153,

Run: 8.63 S Nov 1 2023 Print: 8.630 S Nov 1 2023 MiTek Industries, Inc. Fri Feb 23 10:54:04

Page: 1

ID:3JuH6CXSTCqhpEJEITsC15zPnbv-RfC?PsB70Hq3NSgPqnL8w3uITXbGKwRCDoi7J4zJC?

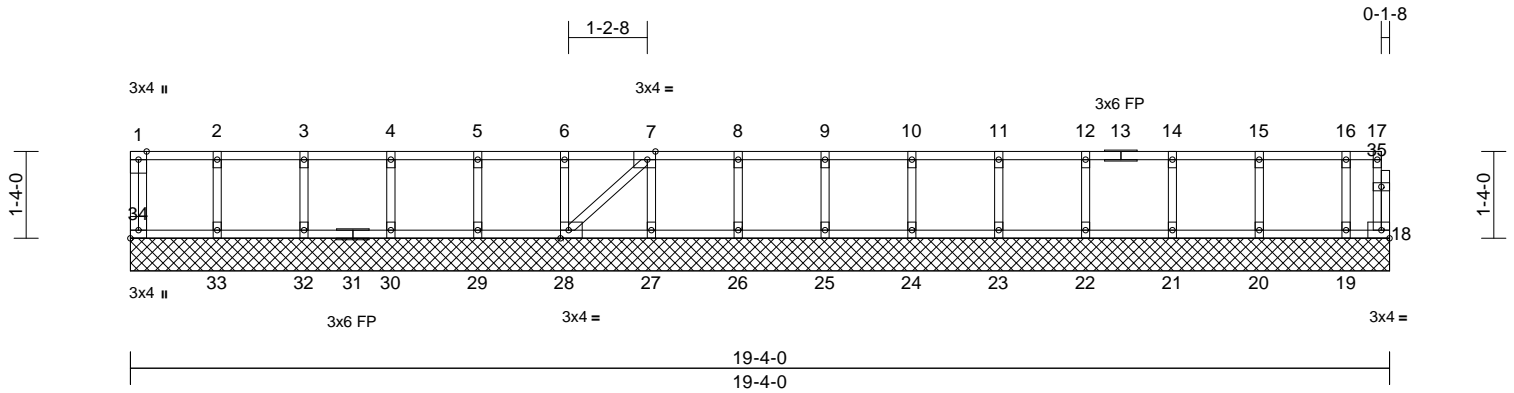

Scale = 1:35.4

Plate Offsets (X, Y): [7:0-1-8,Edge], [28:0-1-8,Edge], [34:Edge,0-1-8]

Loading	(psf)	Spacing	2-0-0	CSI	DEFL	in	(loc)	l/defl	L/d	PLATES	GRIP	
TCLL	40.0	Plate Grip DOL	1.00	TC	0.08	Vert(LL)	n/a	-	n/a	999	MT20	244/190
TCDL	10.0	Lumber DOL	1.00	BC	0.01	Vert(TL)	n/a	-	n/a	999		
BCLL	0.0	Rep Stress Incr	YES	WB	0.03	Horiz(TL)	0.00	18	n/a	n/a		
BCDL	5.0	Code	IRC2015/TPI2014	Matrix-S							Weight: 88 lb	FT = 20%F, 11%E

LUMBER

TOP CHORD 2x4 SP No.2(flat)
 BOT CHORD 2x4 SP No.2(flat)
 WEBS 2x4 SP No.3(flat)
 OTHERS 2x4 SP No.3(flat)

BRACING

TOP CHORD Structural wood sheathing directly applied or 6-0-0 oc purlins, except end verticals.
 BOT CHORD Rigid ceiling directly applied or 10-0-0 oc bracing.

REACTIONS (size) 18=19-4-0, 19=19-4-0, 20=19-4-0, 21=19-4-0, 22=19-4-0, 23=19-4-0, 24=19-4-0, 25=19-4-0, 26=19-4-0, 27=19-4-0, 28=19-4-0, 29=19-4-0, 30=19-4-0, 32=19-4-0, 33=19-4-0, 34=19-4-0

Max Grav 18=2 (LC 1), 19=120 (LC 1), 20=152 (LC 1), 21=145 (LC 1), 22=147 (LC 1), 23=147 (LC 1), 24=147 (LC 1), 25=147 (LC 1), 26=147 (LC 1), 27=147 (LC 1), 28=147 (LC 1), 29=147 (LC 1), 30=147 (LC 1), 32=145 (LC 1), 33=156 (LC 1), 34=52 (LC 1)

FORCES (lb) - Maximum Compression/Maximum Tension

TOP CHORD 1-34=-47/0, 17-18=-2/0, 1-2=0/0, 2-3=0/0, 3-4=0/0, 4-5=0/0, 5-6=0/0, 6-7=0/0, 7-8=0/0, 8-9=0/0, 9-10=0/0, 10-11=0/0, 11-12=0/0, 12-14=0/0, 14-15=0/0, 15-16=0/0, 16-17=0/0
 BOT CHORD 33-34=0/0, 32-33=0/0, 30-32=0/0, 29-30=0/0, 28-29=0/0, 27-28=0/0, 26-27=0/0, 25-26=0/0, 24-25=0/0, 23-24=0/0, 22-23=0/0, 21-22=0/0, 20-21=0/0, 19-20=0/0, 18-19=0/0
 WEBS 2-33=-142/0, 3-32=-132/0, 4-30=-134/0, 5-29=-133/0, 6-28=-133/0, 7-27=-133/0, 8-26=-133/0, 9-25=-133/0, 10-24=-133/0, 11-23=-133/0, 12-22=-134/0, 14-21=-132/0, 15-20=-138/0, 16-19=-109/0, 7-28=0/0

NOTES

- 1) All plates are 1.5x3 MT20 unless otherwise indicated.
- 2) Gable requires continuous bottom chord bearing.
- 3) Truss to be fully sheathed from one face or securely braced against lateral movement (i.e. diagonal web).
- 4) Gable studs spaced at 1-4-0 oc.
- 5) All bearings are assumed to be SP No.2 crushing capacity of 565 psi.
- 6) This truss is designed in accordance with the 2015 International Residential Code sections R502.11.1 and R802.10.2 and referenced standard ANSI/TPI 1.
- 7) Recommend 2x6 strongbacks, on edge, spaced at 10-00-00 oc and fastened to each truss with 3-10d (0.131" X 3") nails. Strongbacks to be attached to walls at their outer ends or restrained by other means.
- 8) CAUTION, Do not erect truss backwards.

LOAD CASE(S) Standard

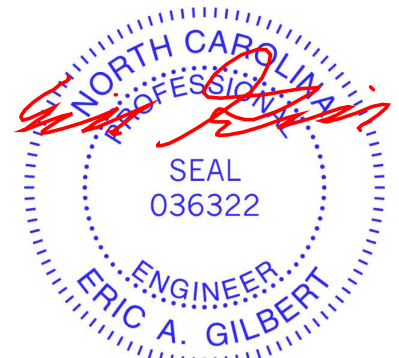

February 26, 2024

WARNING - Verify design parameters and READ NOTES ON THIS AND INCLUDED MITEK REFERENCE PAGE MII-7473 rev. 1/2/2023 BEFORE USE.

Design valid for use only with MiTek® connectors. This design is based only upon parameters shown, and is for an individual building component, not a truss system. Before use, the building designer must verify the applicability of design parameters and properly incorporate this design into the overall building design. Bracing indicated is to prevent buckling of individual truss web and/or chord members only. Additional temporary and permanent bracing is always required for stability and to prevent collapse with possible personal injury and property damage. For general guidance regarding the fabrication, storage, delivery, erection and bracing of trusses and truss systems, see **ANSI/TPI1 Quality Criteria and DSB-22** available from Truss Plate Institute (www.tpinst.org) and **BCSI Building Component Safety Information** available from the Structural Building Component Association (www.sbcacomponents.com)



818 Soundside Road
 Edenton, NC 27932

Job 3894021	Truss F02	Truss Type Floor	Qty 8	Ply 1	Furr, Mayview B Job Reference (optional)	163825696
----------------	--------------	---------------------	----------	----------	---------------------------------------------	-----------

Builders FirstSource (Sumter, SC), Sumter, SC - 29153,

Run: 8.63 S Nov 1 2023 Print: 8.630 S Nov 1 2023 MiTek Industries, Inc. Fri Feb 23 10:54:09
ID:i5ZzVgGfeR2pAsd00rS28TzPncF-RfC?PsB70Hq3NSgPqnL8w3ulTXbGKWrCDoi7J4zJC?f

Page: 1

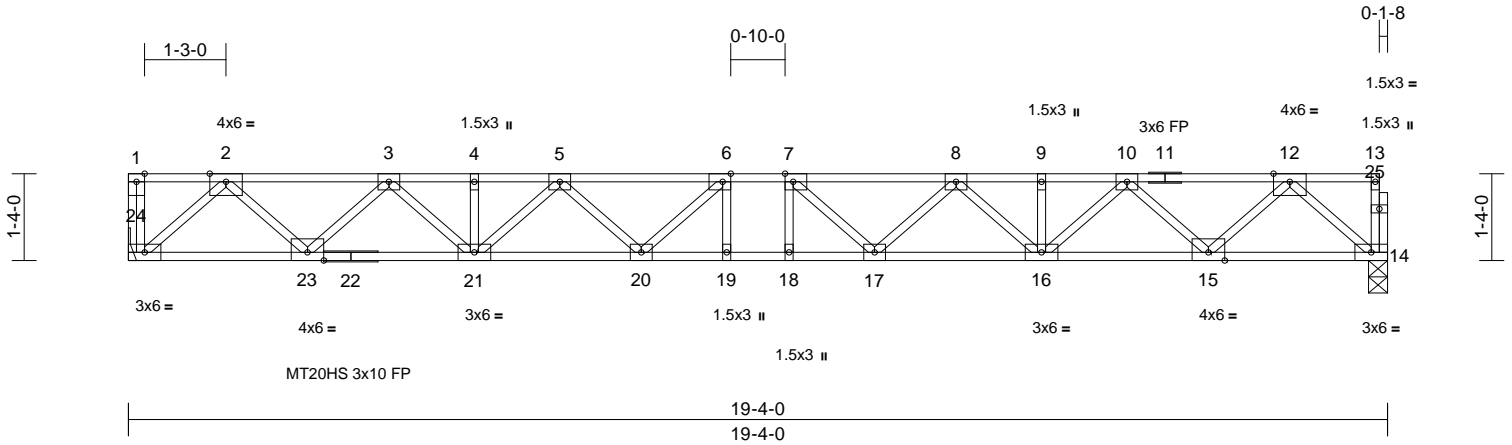

Scale = 1:35.4

Plate Offsets (X, Y): [6:0-1-8,Edge], [7:0-1-8,Edge]

Loading	(psf)	Spacing	2-0-0	CSI	DEFL	in	(loc)	l/defl	L/d	PLATES	GRIP	
TCLL	40.0	Plate Grip DOL	1.00	TC	0.70	Vert(LL)	-0.31	18-19	>739	480	MT20HS	187/143
TCDL	10.0	Lumber DOL	1.00	BC	0.80	Vert(CT)	-0.43	18-19	>537	360	MT20	244/190
BCLL	0.0	Rep Stress Incr	YES	WB	0.53	Horz(CT)	0.08	14	n/a	n/a		
BCDL	5.0	Code	IRC2015/TPI2014	Matrix-S								
											Weight: 104 lb	FT = 20%F, 11%E

LUMBER
TOP CHORD 2x4 SP No.2(flat)
BOT CHORD 2x4 SP No.2(flat) *Except* 22-14:2x4 SP No.1(flat)
WEBS 2x4 SP No.3(flat)
OTHERS 2x4 SP No.3(flat)

BRACING
TOP CHORD Structural wood sheathing directly applied or 4-11-2 oc purlins, except end verticals.
BOT CHORD Rigid ceiling directly applied or 10-0-0 oc bracing.

REACTIONS (size) 14=0-3-8, 24= Mechanical
Max Grav 14=1043 (LC 1), 24=1050 (LC 1)

FORCES (lb) - Maximum Compression/Maximum Tension
TOP CHORD 1-24=-39/0, 13-14=-35/0, 1-2=0/0, 2-3=-1937/0, 3-4=-3271/0, 4-5=-3271/0, 5-6=-3955/0, 6-7=-4151/0, 7-8=-3955/0, 8-9=-3271/0, 9-10=-3271/0, 10-12=-1936/0, 12-13=-2/0
BOT CHORD 23-24=0/1136, 21-23=0/2707, 20-21=0/3746, 19-20=0/4151, 18-19=0/4151, 17-18=0/4151, 16-17=0/3746, 15-16=0/2707, 14-15=0/1135
WEBS 12-14=-1509/0, 12-15=0/1114, 10-15=-1073/0, 10-16=0/765, 9-16=-56/0, 2-24=-1512/0, 2-23=0/1114, 3-23=-1072/0, 3-21=0/766, 4-21=-56/0, 5-21=-647/0, 5-20=0/412, 8-16=-647/0, 8-17=0/412, 7-17=-485/97, 6-20=-484/97, 7-18=-185/201, 6-19=-185/201

- NOTES**
- Unbalanced floor live loads have been considered for this design.
 - All plates are MT20 plates unless otherwise indicated.
 - All plates are 3x4 MT20 unless otherwise indicated.
 - Bearings are assumed to be: , Joint 14 SP No.1 crushing capacity of 565 psi.
 - Refer to girder(s) for truss to truss connections.

- This truss is designed in accordance with the 2015 International Residential Code sections R502.11.1 and R802.10.2 and referenced standard ANSI/TPI 1.
- Recommend 2x6 strongbacks, on edge, spaced at 10-00-00 oc and fastened to each truss with 3-10d (0.131" X 3") nails. Strongbacks to be attached to walls at their outer ends or restrained by other means.
- CAUTION, Do not erect truss backwards.

LOAD CASE(S) Standard



February 26, 2024

WARNING - Verify design parameters and READ NOTES ON THIS AND INCLUDED MITEK REFERENCE PAGE MII-7473 rev. 1/2/2023 BEFORE USE.

Design valid for use only with MiTek® connectors. This design is based only upon parameters shown, and is for an individual building component, not a truss system. Before use, the building designer must verify the applicability of design parameters and properly incorporate this design into the overall building design. Bracing indicated is to prevent buckling of individual truss web and/or chord members only. Additional temporary and permanent bracing is always required for stability and to prevent collapse with possible personal injury and property damage. For general guidance regarding the fabrication, storage, delivery, erection and bracing of trusses and truss systems, see **ANSI/TPH Quality Criteria and DSB-22** available from Truss Plate Institute (www.tpinst.org) and **BCSI Building Component Safety Information** available from the Structural Building Component Association (www.sbcacomponents.com)



818 Soundside Road
Edenton, NC 27932

Job 3894021	Truss F03	Truss Type Floor	Qty 4	Ply 1	Furr, Mayview B Job Reference (optional)	163825697
----------------	--------------	---------------------	----------	----------	---------------------------------------------	-----------

Builders FirstSource (Sumter, SC), Sumter, SC - 29153,

Run: 8.63 S Nov 1 2023 Print: 8.630 S Nov 1 2023 MiTek Industries, Inc. Fri Feb 23 10:54:10
ID:Xn_5uMlIDk58z?hiMFAqluzPnbd-RfC?PsB70Hq3NSgPqnL8w3uITXbGKWrCDoi7J4zJC?f

Page: 1

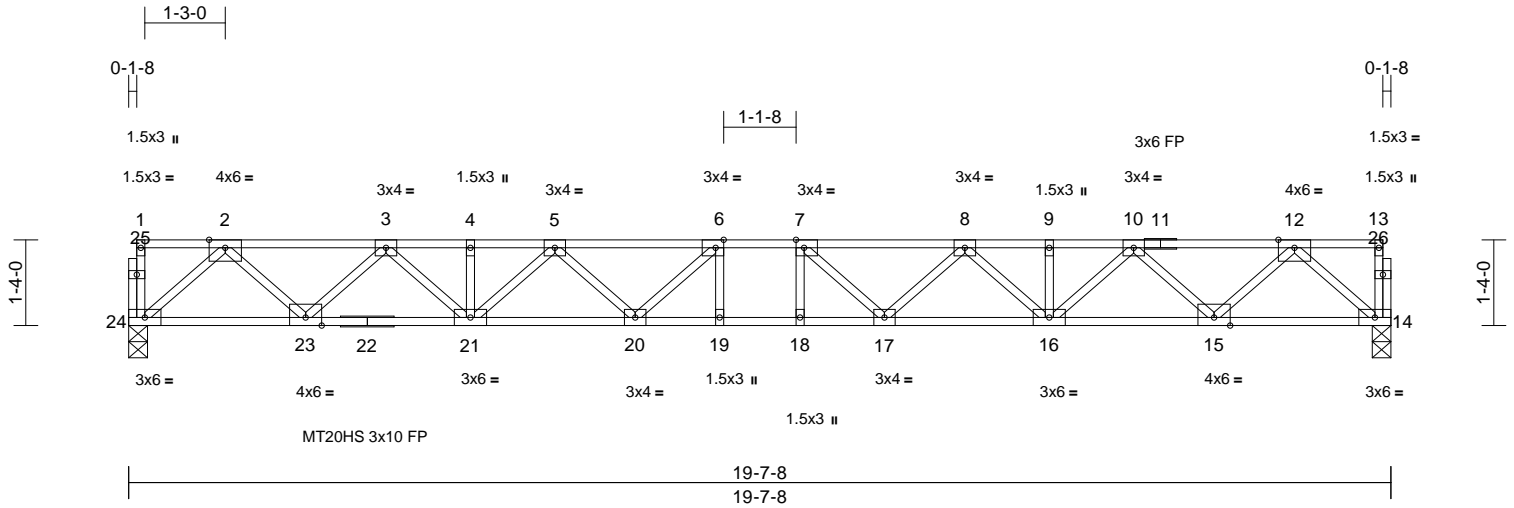

Scale = 1:35.8
Plate Offsets (X, Y): [6:0-1-8,Edge], [7:0-1-8,Edge]

Loading	(psf)	Spacing	2-0-0	CSI	DEFL	in	(loc)	l/defl	L/d	PLATES	GRIP	
TCLL	40.0	Plate Grip DOL	1.00	TC	0.73	Vert(LL)	-0.33	18-19	>707	480	MT20HS	187/143
TCDL	10.0	Lumber DOL	1.00	BC	0.88	Vert(CT)	-0.45	18-19	>514	360	MT20	244/190
BCLL	0.0	Rep Stress Incr	YES	WB	0.54	Horz(CT)	0.08	14	n/a	n/a		
BCDL	5.0	Code	IRC2015/TPI2014	Matrix-S								Weight: 105 lb FT = 20%F, 11%E

LUMBER
TOP CHORD 2x4 SP No.2(flat)
BOT CHORD 2x4 SP No.2(flat) *Except* 22-14:2x4 SP No.1(flat)
WEBS 2x4 SP No.3(flat)
OTHERS 2x4 SP No.3(flat)

BRACING
TOP CHORD Structural wood sheathing directly applied or 4-8-4 oc purlins, except end verticals.
BOT CHORD Rigid ceiling directly applied or 10-0-0 oc bracing.

REACTIONS (size) 14=0-3-8, 24=0-3-8
Max Grav 14=1059 (LC 1), 24=1059 (LC 1)

FORCES (lb) - Maximum Compression/Maximum Tension
TOP CHORD 1-24=-35/0, 13-14=-35/0, 1-2=-2/0, 2-3=-1971/0, 3-4=-3339/0, 4-5=-3339/0, 5-6=-4057/0, 6-7=-4270/0, 7-8=-4057/0, 8-9=-3339/0, 9-10=-3339/0, 10-12=-1971/0, 12-13=-2/0
BOT CHORD 23-24=0/1153, 21-23=0/2759, 20-21=0/3833, 19-20=0/4270, 18-19=0/4270, 17-18=0/4270, 16-17=0/3833, 15-16=0/2759, 14-15=0/1153
WEBS 12-14=-1533/0, 12-15=0/1137, 10-15=-1096/0, 10-16=0/789, 9-16=-55/0, 8-16=-671/0, 8-17=0/437, 7-17=-531/95, 7-18=-185/205, 2-24=-1533/0, 2-23=0/1137, 3-23=-1096/0, 3-21=0/789, 4-21=-55/0, 5-21=-671/0, 5-20=0/438, 6-20=-531/95, 6-19=-186/205

NOTES
1) Unbalanced floor live loads have been considered for this design.
2) All plates are MT20 plates unless otherwise indicated.
3) All plates are 1.5x3 MT20 unless otherwise indicated.
4) Bearings are assumed to be: Joint 24 SP No.2 crushing capacity of 565 psi, Joint 14 SP No.1 crushing capacity of 565 psi.

5) This truss is designed in accordance with the 2015 International Residential Code sections R502.11.1 and R802.10.2 and referenced standard ANSI/TPI 1.
6) Recommend 2x6 strongbacks, on edge, spaced at 10-00-00 oc and fastened to each truss with 3-10d (0.131" X 3") nails. Strongbacks to be attached to walls at their outer ends or restrained by other means.

LOAD CASE(S) Standard

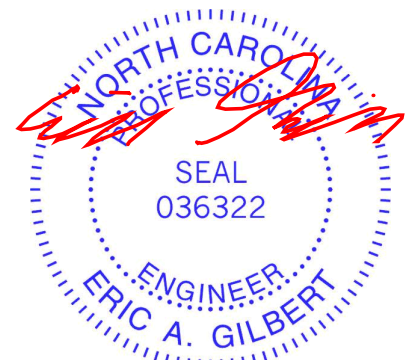

February 26, 2024

Job 3894021	Truss F04	Truss Type Floor Supported Gable	Qty 1	Ply 1	Furr, Mayview B Job Reference (optional)	163825698
----------------	--------------	-------------------------------------	----------	----------	---------------------------------------------	-----------

Builders FirstSource (Sumter, SC), Sumter, SC - 29153,

Run: 8.63 S Nov 1 2023 Print: 8.630 S Nov 1 2023 MiTek Industries, Inc. Fri Feb 23 10:54:10
ID:Tf7QrcUie3Ww2jkQ0p7CtfzPn2-RfC?PsB70Hq3NSgPqnL8w3uITXbGKwRCDoi7J4zJC?#

Page: 1

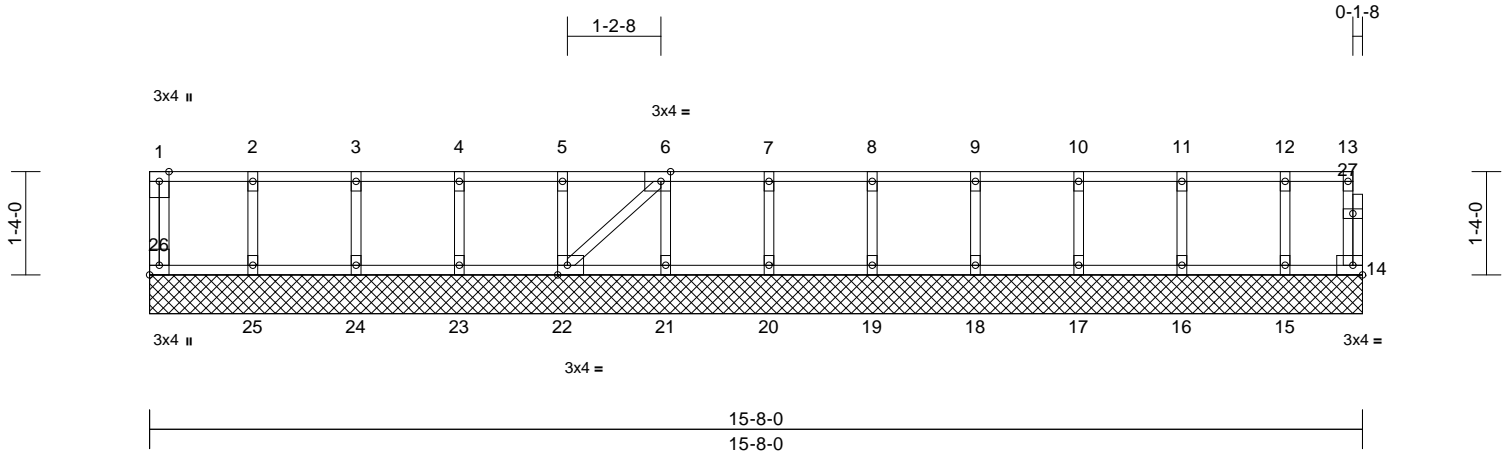

Scale = 1:29.8

Plate Offsets (X, Y): [6:0-1-8,Edge], [22:0-1-8,Edge], [26:Edge,0-1-8]

Loading	(psf)	Spacing	2-0-0	CSI	DEFL	in	(loc)	l/defl	L/d	PLATES	GRIP	
TCLL	40.0	Plate Grip DOL	1.00	TC	0.08	Vert(LL)	n/a	-	n/a	999	MT20	244/190
TCDL	10.0	Lumber DOL	1.00	BC	0.01	Vert(TL)	n/a	-	n/a	999		
BCLL	0.0	Rep Stress Incr	YES	WB	0.03	Horiz(TL)	0.00	14	n/a	n/a		
BCDL	5.0	Code	IRC2015/TPI2014	Matrix-S							Weight: 73 lb	FT = 20%F, 11%E

LUMBER

TOP CHORD 2x4 SP No.2(flat)
BOT CHORD 2x4 SP No.2(flat)
WEBS 2x4 SP No.3(flat)
OTHERS 2x4 SP No.3(flat)

BRACING

TOP CHORD Structural wood sheathing directly applied or 6-0-0 oc purlins, except end verticals.
BOT CHORD Rigid ceiling directly applied or 10-0-0 oc bracing.

REACTIONS (size) 14=15-8-0, 15=15-8-0, 16=15-8-0, 17=15-8-0, 18=15-8-0, 19=15-8-0, 20=15-8-0, 21=15-8-0, 22=15-8-0, 23=15-8-0, 24=15-8-0, 25=15-8-0, 26=15-8-0

Max Grav 14=29 (LC 1), 15=131 (LC 1), 16=150 (LC 1), 17=146 (LC 1), 18=147 (LC 1), 19=147 (LC 1), 20=147 (LC 1), 21=145 (LC 1), 22=148 (LC 1), 23=147 (LC 1), 24=145 (LC 1), 25=156 (LC 1), 26=52 (LC 1)

FORCES (lb) - Maximum Compression/Maximum Tension

TOP CHORD 1-26=-47/0, 13-14=-26/0, 1-2=0/0, 2-3=0/0, 3-4=0/0, 4-5=0/0, 5-6=0/0, 6-7=-1/0, 7-8=-1/0, 8-9=-1/0, 9-10=-1/0, 10-11=-1/0, 11-12=-1/0, 12-13=-1/0

BOT CHORD 25-26=0/0, 24-25=0/0, 23-24=0/0, 22-23=0/0, 21-22=0/1, 20-21=0/1, 19-20=0/1, 18-19=0/1, 17-18=0/1, 16-17=0/1, 15-16=0/1, 14-15=0/1

WEBS 2-25=-142/0, 3-24=-132/0, 4-23=-134/0, 5-22=-133/0, 6-21=-132/0, 7-20=-133/0, 8-19=-133/0, 9-18=-134/0, 10-17=-132/0, 11-16=-137/0, 12-15=-119/0, 6-22=-2/0

NOTES

- 1) All plates are 1.5x3 MT20 unless otherwise indicated.
- 2) Gable requires continuous bottom chord bearing.

- 3) Truss to be fully sheathed from one face or securely braced against lateral movement (i.e. diagonal web).
- 4) Gable studs spaced at 1-4-0 oc.
- 5) All bearings are assumed to be SP No.2 crushing capacity of 565 psi.
- 6) This truss is designed in accordance with the 2015 International Residential Code sections R502.11.1 and R802.10.2 and referenced standard ANSI/TPI 1.
- 7) Recommend 2x6 strongbacks, on edge, spaced at 10-00-00 oc and fastened to each truss with 3-10d (0.131" X 3") nails. Strongbacks to be attached to walls at their outer ends or restrained by other means.
- 8) CAUTION, Do not erect truss backwards.

LOAD CASE(S) Standard

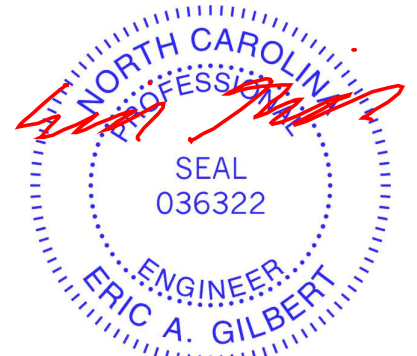

February 26, 2024

WARNING - Verify design parameters and READ NOTES ON THIS AND INCLUDED MITEK REFERENCE PAGE MII-7473 rev. 1/2/2023 BEFORE USE.

Design valid for use only with MiTek® connectors. This design is based only upon parameters shown, and is for an individual building component, not a truss system. Before use, the building designer must verify the applicability of design parameters and properly incorporate this design into the overall building design. Bracing indicated is to prevent buckling of individual truss web and/or chord members only. Additional temporary and permanent bracing is always required for stability and to prevent collapse with possible personal injury and property damage. For general guidance regarding the fabrication, storage, delivery, erection and bracing of trusses and truss systems, see **ANSI/TPI1 Quality Criteria and DSB-22** available from Truss Plate Institute (www.tpinst.org) and **BCSI Building Component Safety Information** available from the Structural Building Component Association (www.sbcacomponents.com)



818 Soundside Road
Edenton, NC 27932

Job 3894021	Truss F05	Truss Type Floor	Qty 1	Ply 1	Furr, Mayview B Job Reference (optional)	I63825699
----------------	--------------	---------------------	----------	----------	---------------------------------------------	-----------

Builders FirstSource (Sumter, SC), Sumter, SC - 29153,

Run: 8.63 S Nov 1 2023 Print: 8.630 S Nov 1 2023 MiTek Industries, Inc. Fri Feb 23 10:54:11
ID:vbMgEC1MSixjCWIPdg_b9rzPnSD-RfC?PsB70Hq3NSgPqnL8w3uITXbGKWrCDoi7J4zJC?f

Page: 1

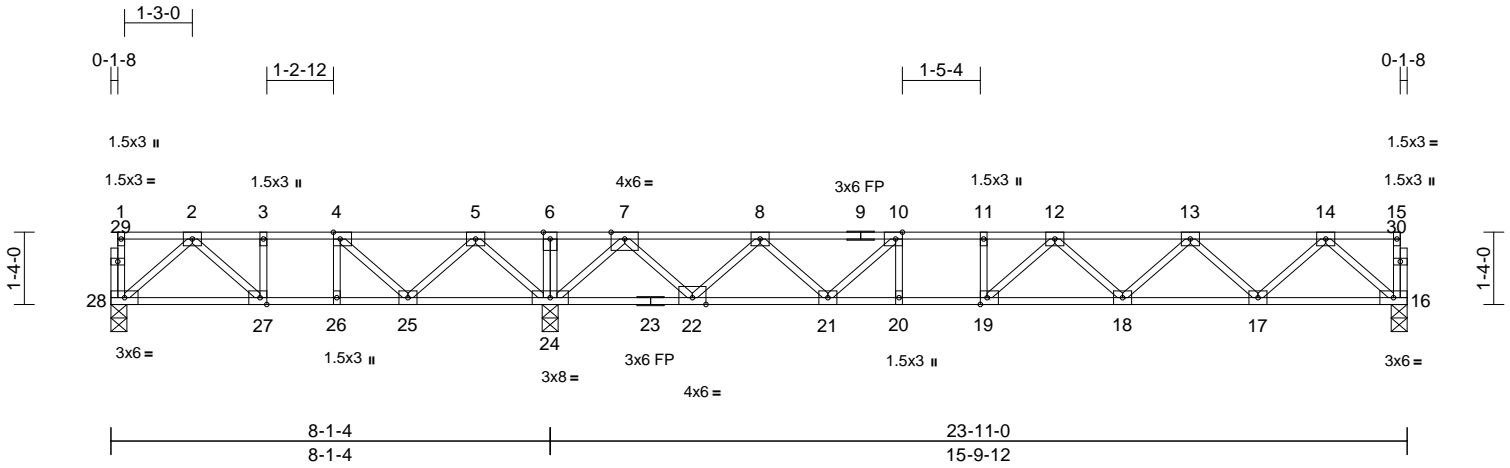

Scale = 1:42.5

Plate Offsets (X, Y): [4:0-1-8,Edge], [10:0-1-8,Edge], [19:0-1-8,Edge], [27:0-1-8,Edge]

Loading	(psf)	Spacing	2-0-0	CSI	DEFL	in	(loc)	l/defl	L/d	PLATES	GRIP
TCLL	40.0	Plate Grip DOL	1.00	TC	Vert(LL)	-0.15	18-19	>999	480	MT20	244/190
TCDL	10.0	Lumber DOL	1.00	BC	Vert(CT)	-0.21	18-19	>900	360		
BCLL	0.0	Rep Stress Incr	YES	WB	Horz(CT)	0.03	16	n/a	n/a		
BCDL	5.0	Code	IRC2015/TPI2014	Matrix-S						Weight: 126 lb	FT = 20%F, 11%E

LUMBER
TOP CHORD 2x4 SP No.2(flat)
BOT CHORD 2x4 SP No.2(flat) *Except* 23-16:2x4 SP No.1(flat)
WEBS 2x4 SP No.3(flat)
OTHERS 2x4 SP No.3(flat)

BRACING
TOP CHORD Structural wood sheathing directly applied or 6-0-0 oc purlins, except end verticals.
BOT CHORD Rigid ceiling directly applied or 6-0-0 oc bracing.

REACTIONS (size) 16=0-3-8, 24=0-3-8, 28=0-3-8
Max Uplift 28=52 (LC 4)
Max Grav 16=770 (LC 7), 24=1613 (LC 1), 28=342 (LC 3)

FORCES (lb) - Maximum Compression/Maximum Tension
TOP CHORD 1-28=-52/1, 15-16=-37/0, 1-2=-3/0, 2-3=-455/278, 3-4=-455/278, 4-5=-211/579, 5-6=0/1385, 6-7=0/1385, 7-8=-603/73, 8-10=-1685/0, 10-11=-2165/0, 11-12=-2165/0, 12-13=-2083/0, 13-14=-1345/0, 14-15=-2/0
BOT CHORD 27-28=-87/321, 26-27=-278/455, 25-26=-278/455, 24-25=-828/0, 22-24=-355/0, 21-22=0/1269, 20-21=0/2165, 19-20=0/2165, 18-19=0/2262, 17-18=0/1848, 16-17=0/822
WEBS 6-24=-106/0, 14-16=-1091/0, 14-17=0/729, 13-17=-699/0, 13-18=0/327, 12-18=-248/0, 12-19=-338/155, 11-19=-74/79, 7-24=-1372/0, 7-22=0/998, 8-21=0/614, 8-22=-955/0, 10-21=-736/0, 10-20=-3/239, 5-24=-863/0, 2-28=-423/116, 2-27=-260/183, 5-25=0/544, 4-25=-591/0, 3-27=-95/118, 4-26=0/154

- Unbalanced floor live loads have been considered for this design.
- All plates are 3x4 MT20 unless otherwise indicated.
- Bearings are assumed to be: Joint 28 SP No.2 crushing capacity of 565 psi, Joint 24 SP No.2 crushing capacity of 565 psi, Joint 16 SP No.1 crushing capacity of 565 psi.
- Provide mechanical connection (by others) of truss to bearing plate capable of withstanding 52 lb uplift at joint 28.
- This truss is designed in accordance with the 2015 International Residential Code sections R502.11.1 and R802.10.2 and referenced standard ANSI/TPI 1.
- Recommend 2x6 strongbacks, on edge, spaced at 10-00-00 oc and fastened to each truss with 3-10d (0.131" X 3") nails. Strongbacks to be attached to walls at their outer ends or restrained by other means.
- CAUTION, Do not erect truss backwards.

LOAD CASE(S) Standard

NOTES



February 26, 2024

WARNING - Verify design parameters and READ NOTES ON THIS AND INCLUDED MITEK REFERENCE PAGE MII-7473 rev. 1/2/2023 BEFORE USE.

Design valid for use only with MiTek® connectors. This design is based only upon parameters shown, and is for an individual building component, not a truss system. Before use, the building designer must verify the applicability of design parameters and properly incorporate this design into the overall building design. Bracing indicated is to prevent buckling of individual truss web and/or chord members only. Additional temporary and permanent bracing is always required for stability and to prevent collapse with possible personal injury and property damage. For general guidance regarding the fabrication, storage, delivery, erection and bracing of trusses and truss systems, see **ANSI/TPI1 Quality Criteria and DSB-22** available from Truss Plate Institute (www.tpinst.org) and **BCSI Building Component Safety Information** available from the Structural Building Component Association (www.sbcacomponents.com)



818 Soundside Road
Edenton, NC 27932

Job 3894021	Truss F06	Truss Type Floor Girder	Qty 1	Ply 1	Furr, Mayview B Job Reference (optional)	163825700
----------------	--------------	----------------------------	----------	----------	---------------------------------------------	-----------

Builders FirstSource (Sumter, SC), Sumter, SC - 29153,

Run: 8.63 S Nov 1 2023 Print: 8.630 S Nov 1 2023 MiTek Industries, Inc. Fri Feb 23 10:54:11
ID:Am9wEb?_ITLkdQ5X6iauj0zPnPh-RfC?PsB70Hq3NSgPqnL8w3uTXbGKWrCDoi7J4zJC?f

Page: 1

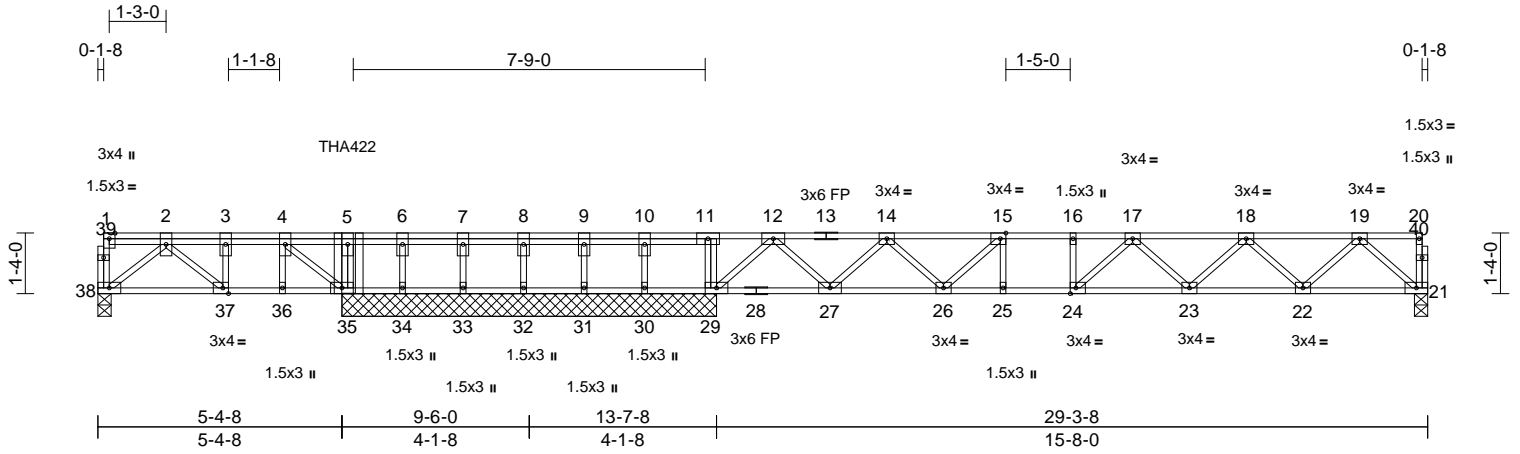

Scale = 1:50.8

Plate Offsets (X, Y): [15:0-1-8,Edge], [24:0-1-8,Edge], [37:0-1-8,Edge]

Loading	(psf)	Spacing	2-0-0	CSI	DEFL	in	(loc)	l/defl	L/d	PLATES	GRIP	
TCLL	40.0	Plate Grip DOL	1.00	TC	0.61	Vert(LL)	-0.16	23-24	>999	480	MT20	244/190
TCDL	10.0	Lumber DOL	1.00	BC	0.96	Vert(CT)	-0.22	23-24	>848	360		
BCLL	0.0	Rep Stress Incr	NO	WB	0.45	Horz(CT)	0.03	21	n/a	n/a		
BCDL	5.0	Code	IRC2015/TPI2014	Matrix-S								
											Weight: 166 lb	FT = 20%F, 11%E

LUMBER
TOP CHORD 2x4 SP No.2(flat)
BOT CHORD 2x4 SP No.2(flat)
WEBS 2x4 SP No.3(flat)
OTHERS 2x4 SP No.3(flat)

BRACING
TOP CHORD Structural wood sheathing directly applied or 6-0-0 oc purlins, except end verticals.
BOT CHORD Rigid ceiling directly applied or 6-0-0 oc bracing.

REACTIONS (size) 21=0-3-8, 29=8-3-0, 30=8-3-0, 31=8-3-0, 32=8-3-0, 33=8-3-0, 34=8-3-0, 35=8-3-0, 38=0-3-8
Max Uplift 30=55 (LC 4), 38=88 (LC 4)
Max Grav 21=789 (LC 4), 29=1077 (LC 1), 30=133 (LC 3), 31=174 (LC 1), 32=147 (LC 3), 33=141 (LC 3), 34=222 (LC 1), 35=1226 (LC 1), 38=245 (LC 3)

FORCES (lb) - Maximum Compression/Maximum Tension
TOP CHORD 1-38=-46/6, 20-21=-37/0, 1-2=-6/0, 2-3=-192/386, 3-4=-192/386, 4-5=0/840, 5-6=0/840, 6-7=0/840, 7-8=0/840, 8-9=0/840, 9-10=0/840, 10-11=0/840, 11-12=0/856, 12-14=-807/0, 14-15=-1853/0, 15-16=-2293/0, 16-17=-2293/0, 17-18=-2158/0, 18-19=-1386/0, 19-20=-2/0
BOT CHORD 37-38=-118/224, 36-37=-386/192, 35-36=-386/192, 34-35=-840/0, 33-34=-840/0, 32-33=-840/0, 31-32=-840/0, 30-31=-840/0, 29-30=-840/0, 27-29=0/134, 26-27=0/1458, 25-26=0/2293, 24-25=0/2293, 23-24=0/2360, 22-23=0/1906, 21-22=0/842

WEBS 5-35=-816/0, 11-29=-165/0, 19-21=-1119/0, 19-22=0/756, 18-22=-724/0, 18-23=0/350, 17-23=-281/0, 17-24=-91/0, 16-24=0/12, 12-29=-1314/0, 12-27=0/936, 14-27=-906/0, 14-26=0/549, 15-26=-599/0, 15-25=0/108, 2-38=-288/153, 4-35=-864/0, 2-37=-357/0, 3-37=0/231, 4-36=0/64, 6-34=-197/0, 7-33=-128/0, 8-32=-134/0, 9-31=-154/0, 10-30=-127/45

NOTES
1) Unbalanced floor live loads have been considered for this design.
2) All plates are 3x6 MT20 unless otherwise indicated.
3) Truss to be fully sheathed from one face or securely braced against lateral movement (i.e. diagonal web).
4) Gable studs spaced at 1-4-0 oc.
5) All bearings are assumed to be SP No.2 crushing capacity of 565 psi.
6) Provide mechanical connection (by others) of truss to bearing plate capable of withstanding 88 lb uplift at joint 38 and 55 lb uplift at joint 30.
7) This truss is designed in accordance with the 2015 International Residential Code sections R502.11.1 and R802.10.2 and referenced standard ANSI/TPI 1.
8) Recommend 2x6 strongbacks, on edge, spaced at 10-00-00 oc and fastened to each truss with 3-10d (0.131" X 3") nails. Strongbacks to be attached to walls at their outer ends or restrained by other means.
9) CAUTION, Do not erect truss backwards.
10) Use Simpson Strong-Tie THA422 (6-16d Girder, 6-10d Truss) or equivalent at 5-6-4 from the left end to connect truss(es) to back face of top chord.
11) Fill all nail holes where hanger is in contact with lumber.
12) In the LOAD CASE(S) section, loads applied to the face of the truss are noted as front (F) or back (B).

LOAD CASE(S) Standard
1) Dead + Floor Live (balanced): Lumber Increase=1.00, Plate Increase=1.00
Uniform Loads (lb/ft)

Vert: 21-38=-10, 1-20=-100
Concentrated Loads (lb)
Vert: 5=-764 (B)



February 26, 2024

Job 3894021	Truss F07	Truss Type Floor	Qty 13	Ply 1	Furr, Mayview B Job Reference (optional)	I63825701
----------------	--------------	---------------------	-----------	----------	---------------------------------------------	-----------

Builders FirstSource (Sumter, SC), Sumter, SC - 29153,

Run: 8.63 S Nov 1 2023 Print: 8.630 S Nov 1 2023 MiTek Industries, Inc. Fri Feb 23 10:54:13
ID:uFjYP8?2TaEnVSj38KyfCwzPnTY-RfC?PsB70Hq3NSgPqnL8w3uITXbGKWrCDoi7J4zJC?f

Page: 1

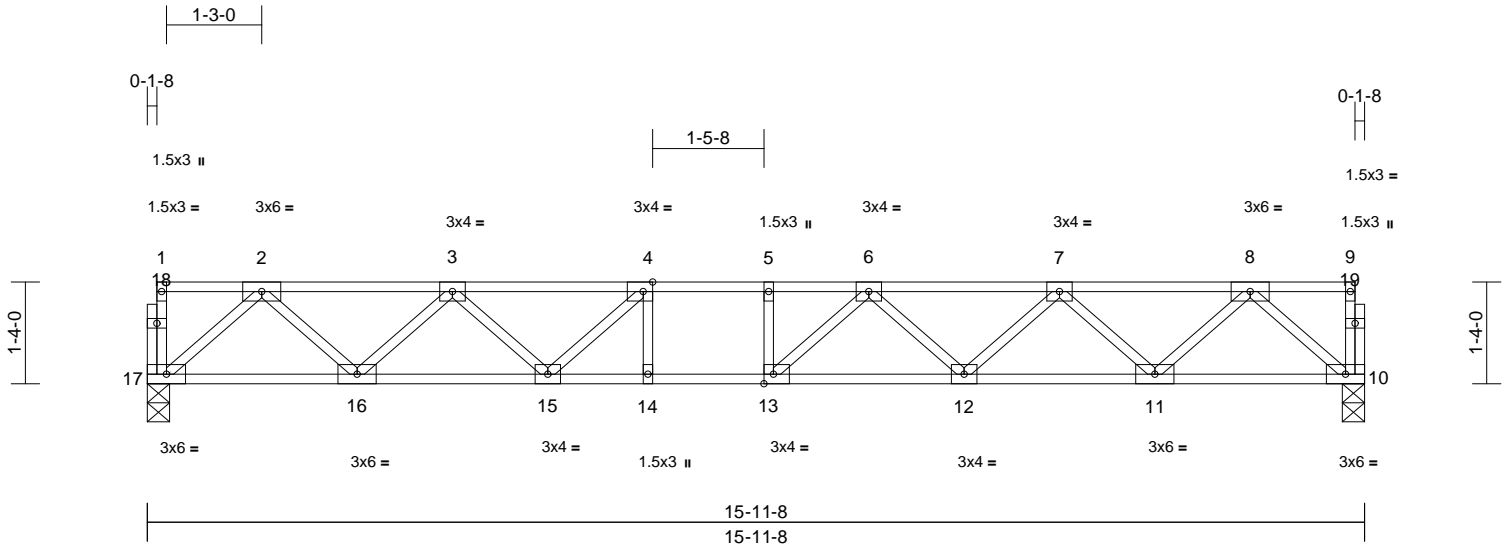

Scale = 1:30.2

Plate Offsets (X, Y): [4:0-1-8,Edge], [13:0-1-8,Edge]

Loading	(psf)	Spacing	2-0-0	CSI	DEFL	in	(loc)	l/defl	L/d	PLATES	GRIP	
TCLL	40.0	Plate Grip DOL	1.00	TC	0.53	Vert(LL)	-0.17	12-13	>999	480	MT20	244/190
TCDL	10.0	Lumber DOL	1.00	BC	0.98	Vert(CT)	-0.23	12-13	>810	360		
BCLL	0.0	Rep Stress Incr	YES	WB	0.41	Horz(CT)	0.05	10	n/a	n/a		
BCDL	5.0	Code	IRC2015/TPI2014	Matrix-S							Weight: 83 lb	FT = 20%F, 11%E

LUMBER **LOAD CASE(S)** Standard
 TOP CHORD 2x4 SP No.2(flat)
 BOT CHORD 2x4 SP No.2(flat)
 WEBS 2x4 SP No.3(flat)
 OTHERS 2x4 SP No.3(flat)

BRACING
 TOP CHORD Structural wood sheathing directly applied or 6-0-0 oc purlins, except end verticals.
 BOT CHORD Rigid ceiling directly applied or 2-2-0 oc bracing.

REACTIONS (size) 10=0-3-8, 17=0-3-8
 Max Grav 10=858 (LC 1), 17=858 (LC 1)

FORCES (lb) - Maximum Compression/Maximum Tension
 TOP CHORD 1-17=-40/0, 9-10=-38/0, 1-2=-2/0, 2-3=-1538/0, 3-4=-2439/0, 4-5=-2773/0, 5-6=-2773/0, 6-7=-2444/0, 7-8=-1537/0, 8-9=-2/0
 BOT CHORD 16-17=0/923, 15-16=0/2121, 14-15=0/2773, 13-14=0/2773, 12-13=0/2725, 11-12=0/2126, 10-11=0/921
 WEBS 8-10=-1223/0, 8-11=0/857, 7-11=-820/0, 7-12=0/441, 2-17=-1226/0, 2-16=0/856, 3-16=-811/0, 3-15=0/483, 6-12=-391/0, 4-15=-579/0, 6-13=-187/370, 5-13=-159/32, 4-14=-83/166

- NOTES**
- 1) Unbalanced floor live loads have been considered for this design.
 - 2) All bearings are assumed to be SP No.2 crushing capacity of 565 psi.
 - 3) This truss is designed in accordance with the 2015 International Residential Code sections R502.11.1 and R802.10.2 and referenced standard ANSI/TPI 1.
 - 4) Recommend 2x6 strongbacks, on edge, spaced at 10-00-00 oc and fastened to each truss with 3-10d (0.131" X 3") nails. Strongbacks to be attached to walls at their outer ends or restrained by other means.



February 26, 2024

WARNING - Verify design parameters and READ NOTES ON THIS AND INCLUDED MITEK REFERENCE PAGE MII-7473 rev. 1/2/2023 BEFORE USE.

Design valid for use only with MiTek® connectors. This design is based only upon parameters shown, and is for an individual building component, not a truss system. Before use, the building designer must verify the applicability of design parameters and properly incorporate this design into the overall building design. Bracing indicated is to prevent buckling of individual truss web and/or chord members only. Additional temporary and permanent bracing is always required for stability and to prevent collapse with possible personal injury and property damage. For general guidance regarding the fabrication, storage, delivery, erection and bracing of trusses and truss systems, see **ANSI/TPI1 Quality Criteria and DSB-22** available from Truss Plate Institute (www.tpinst.org) and **BCSI Building Component Safety Information** available from the Structural Building Component Association (www.sbcacomponents.com)



818 Soundside Road
Edenton, NC 27932

Job 3894021	Truss F08	Truss Type Floor Supported Gable	Qty 1	Ply 1	Furr, Mayview B Job Reference (optional)	163825702
----------------	--------------	-------------------------------------	----------	----------	---------------------------------------------	-----------

Builders FirstSource (Sumter, SC), Sumter, SC - 29153,

Run: 8.63 S Nov 1 2023 Print: 8.630 S Nov 1 2023 MiTek Industries, Inc. Fri Feb 23 10:54:14
ID:PyLj4o8_vs97_I?KNHErMVy6QMz-RfC?PsB70Hq3NSgPqnL8w3uITXbGKWrCdoi7J4zJC?f

Page: 1

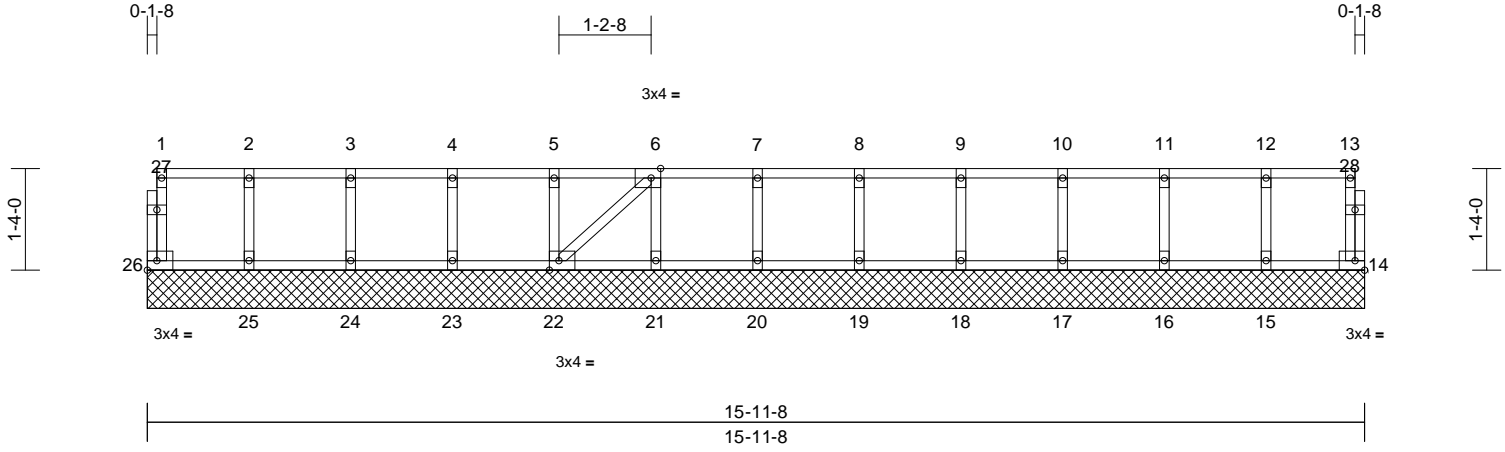

Scale = 1:30.2

Plate Offsets (X, Y): [6:0-1-8,Edge], [22:0-1-8,Edge]

Loading	(psf)	Spacing	2-0-0	CSI	DEFL	in	(loc)	l/defl	L/d	PLATES	GRIP	
TCLL	40.0	Plate Grip DOL	1.00	TC	0.08	Vert(LL)	n/a	-	n/a	999	MT20	244/190
TCDL	10.0	Lumber DOL	1.00	BC	0.01	Vert(TL)	n/a	-	n/a	999		
BCLL	0.0	Rep Stress Incr	YES	WB	0.03	Horiz(TL)	0.00	14	n/a	n/a		
BCDL	5.0	Code	IRC2015/TPI2014	Matrix-S							Weight: 73 lb	FT = 20%F, 11%E

- LUMBER**
- TOP CHORD 2x4 SP No.2(flat)
 - BOT CHORD 2x4 SP No.2(flat)
 - WEBS 2x4 SP No.3(flat)
 - OTHERS 2x4 SP No.3(flat)

- BRACING**
- TOP CHORD Structural wood sheathing directly applied or 6-0-0 oc purlins, except end verticals.
 - BOT CHORD Rigid ceiling directly applied or 10-0-0 oc bracing.

- REACTIONS** (size)
- 14=15-11-8, 15=15-11-8, 16=15-11-8, 17=15-11-8, 18=15-11-8, 19=15-11-8, 20=15-11-8, 21=15-11-8, 22=15-11-8, 23=15-11-8, 24=15-11-8, 25=15-11-8, 26=15-11-8
 - Max Grav 14=46 (LC 1), 15=149 (LC 1), 16=147 (LC 1), 17=147 (LC 1), 18=147 (LC 1), 19=147 (LC 1), 20=147 (LC 1), 21=147 (LC 1), 22=147 (LC 1), 23=147 (LC 1), 24=146 (LC 1), 25=152 (LC 1), 26=49 (LC 1)

- FORCES** (lb) - Maximum Compression/Maximum Tension
- TOP CHORD 1-26=-44/0, 13-14=-42/0, 1-2=-2/0, 2-3=-2/0, 3-4=-2/0, 4-5=-2/0, 5-6=-2/0, 6-7=-2/0, 7-8=-2/0, 8-9=-2/0, 9-10=-2/0, 10-11=-2/0, 11-12=-2/0, 12-13=-2/0
 - BOT CHORD 25-26=0/2, 24-25=0/2, 23-24=0/2, 22-23=0/2, 21-22=0/2, 20-21=0/2, 19-20=0/2, 18-19=0/2, 17-18=0/2, 16-17=0/2, 15-16=0/2, 14-15=0/2
 - WEBS 2-25=-138/0, 3-24=-133/0, 4-23=-134/0, 5-22=-133/0, 6-21=-133/0, 7-20=-133/0, 8-19=-133/0, 9-18=-133/0, 10-17=-133/0, 11-16=-133/0, 12-15=-135/0, 6-22=0/0

NOTES

- All plates are 1.5x3 MT20 unless otherwise indicated.
- Gable requires continuous bottom chord bearing.
- Truss to be fully sheathed from one face or securely braced against lateral movement (i.e. diagonal web).
- Gable studs spaced at 1-4-0 oc.
- All bearings are assumed to be SP No.2 crushing capacity of 565 psi.
- This truss is designed in accordance with the 2015 International Residential Code sections R502.11.1 and R802.10.2 and referenced standard ANSI/TPI 1.
- Recommend 2x6 strongbacks, on edge, spaced at 10-00-00 oc and fastened to each truss with 3-10d (0.131" X 3") nails. Strongbacks to be attached to walls at their outer ends or restrained by other means.

LOAD CASE(S) Standard

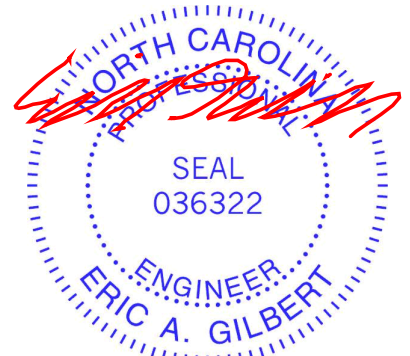

February 26, 2024

WARNING - Verify design parameters and READ NOTES ON THIS AND INCLUDED MITEK REFERENCE PAGE MII-7473 rev. 1/2/2023 BEFORE USE.

Design valid for use only with MiTek® connectors. This design is based only upon parameters shown, and is for an individual building component, not a truss system. Before use, the building designer must verify the applicability of design parameters and properly incorporate this design into the overall building design. Bracing indicated is to prevent buckling of individual truss web and/or chord members only. Additional temporary and permanent bracing is always required for stability and to prevent collapse with possible personal injury and property damage. For general guidance regarding the fabrication, storage, delivery, erection and bracing of trusses and truss systems, see **ANSI/TPI1 Quality Criteria and DSB-22** available from Truss Plate Institute (www.tpinst.org) and **BCSI Building Component Safety Information** available from the Structural Building Component Association (www.sbcacomponents.com)



818 Soundside Road
Edenton, NC 27932

Job 3894021	Truss F09	Truss Type Floor Supported Gable	Qty 1	Ply 1	Furr, Mayview B Job Reference (optional)	163825703
----------------	--------------	-------------------------------------	----------	----------	---------------------------------------------	-----------

Builders FirstSource (Sumter, SC), Sumter, SC - 29153,

Run: 8.63 S Nov 1 2023 Print: 8.630 S Nov 1 2023 MiTek Industries, Inc. Fri Feb 23 10:54:14
ID:UWL_95oKkT2ovNrQy0EqnFzPnaG-RFC?PsB70Hq3NSgPqnL8w3uITXbGKWrcDoi7J4zJC?#

Page: 1

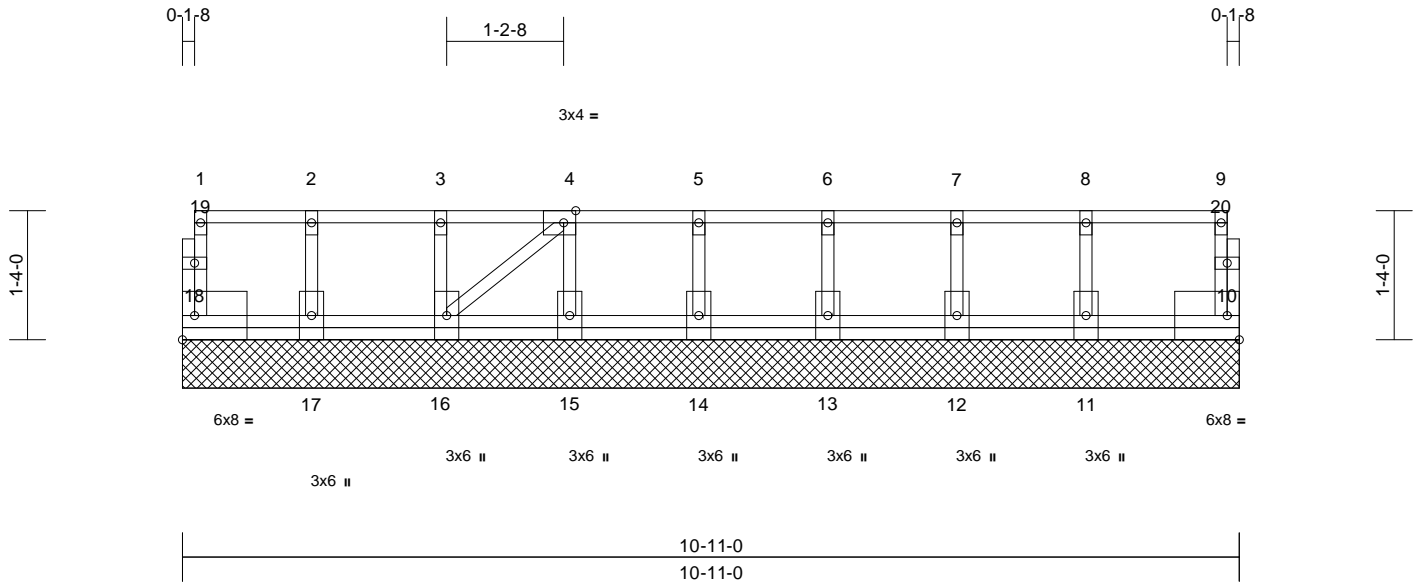

Scale = 1:23.8

Plate Offsets (X, Y): [4:0-1-8,Edge]

Loading	(psf)	Spacing	2-0-0	CSI	DEFL	in	(loc)	l/defl	L/d	PLATES	GRIP
TCLL	40.0	Plate Grip DOL	1.00	TC	Vert(LL)	n/a	-	n/a	999	MT20	244/190
TCDL	10.0	Lumber DOL	1.00	BC	Vert(TL)	n/a	-	n/a	999		
BCLL	0.0	Rep Stress Incr	YES	WB	Horiz(TL)	0.00	10	n/a	n/a		
BCDL	5.0	Code	IRC2015/TPI2014	Matrix-S						Weight: 66 lb	FT = 20%F, 11%E

LUMBER
TOP CHORD 2x4 SP No.2(flat)
BOT CHORD 2x4 SP No.2(flat)
WEBS 2x4 SP No.3(flat)
OTHERS 2x4 SP No.3(flat)

BRACING
TOP CHORD Structural wood sheathing directly applied or 6-0-0 oc purlins, except end verticals.
BOT CHORD Rigid ceiling directly applied or 10-0-0 oc bracing.

REACTIONS (size) 10=10-11-0, 11=10-11-0, 12=10-11-0, 13=10-11-0, 14=10-11-0, 15=10-11-0, 16=10-11-0, 17=10-11-0, 18=10-11-0
Max Grav 10=61 (LC 1), 11=171 (LC 1), 12=140 (LC 1), 13=148 (LC 1), 14=146 (LC 1), 15=146 (LC 1), 16=146 (LC 1), 17=152 (LC 1), 18=49 (LC 1)

FORCES (lb) - Maximum Compression/Maximum Tension
TOP CHORD 1-18=-44/0, 9-10=-56/0, 1-2=-2/0, 2-3=-2/0, 3-4=-2/0, 4-5=-3/0, 5-6=-3/0, 6-7=-3/0, 7-8=-3/0, 8-9=-3/0
BOT CHORD 17-18=0/2, 16-17=0/2, 15-16=0/3, 14-15=0/3, 13-14=0/3, 12-13=0/3, 11-12=0/3, 10-11=0/3
WEBS 2-17=-138/0, 3-16=-133/0, 4-15=-133/0, 5-14=-133/0, 6-13=-135/0, 7-12=-127/0, 8-11=-155/0, 4-16=-1/0

NOTES
1) All plates are 1.5x3 MT20 unless otherwise indicated.
2) Gable requires continuous bottom chord bearing.
3) Truss to be fully sheathed from one face or securely braced against lateral movement (i.e. diagonal web).
4) Gable studs spaced at 1-4-0 oc.
5) All bearings are assumed to be SP No.2 crushing capacity of 565 psi.

6) This truss is designed in accordance with the 2015 International Residential Code sections R502.11.1 and R802.10.2 and referenced standard ANSI/TPI 1.
7) Recommend 2x6 strongbacks, on edge, spaced at 10-00-00 oc and fastened to each truss with 3-10d (0.131" X 3") nails. Strongbacks to be attached to walls at their outer ends or restrained by other means.

LOAD CASE(S) Standard



February 26, 2024

WARNING - Verify design parameters and READ NOTES ON THIS AND INCLUDED MITEK REFERENCE PAGE MII-7473 rev. 1/2/2023 BEFORE USE.
Design valid for use only with MiTek® connectors. This design is based only upon parameters shown, and is for an individual building component, not a truss system. Before use, the building designer must verify the applicability of design parameters and properly incorporate this design into the overall building design. Bracing indicated is to prevent buckling of individual truss web and/or chord members only. Additional temporary and permanent bracing is always required for stability and to prevent collapse with possible personal injury and property damage. For general guidance regarding the fabrication, storage, delivery, erection and bracing of trusses and truss systems, see **ANSI/TPI1 Quality Criteria and DSB-22** available from Truss Plate Institute (www.tpinst.org) and **BCSI Building Component Safety Information** available from the Structural Building Component Association (www.sbcacomponents.com)



Job 3894021	Truss F10	Truss Type Floor	Qty 5	Ply 1	Furr, Mayview B Job Reference (optional)	I63825704
----------------	--------------	---------------------	----------	----------	---------------------------------------------	-----------

Builders FirstSource (Sumter, SC), Sumter, SC - 29153,

Run: 8.63 S Nov 1 2023 Print: 8.630 S Nov 1 2023 MiTek Industries, Inc. Fri Feb 23 10:54:14

Page: 1

ID:8NWNpqMAvbrGRRMGeh3cezzPnZY-RfC?PsB70Hq3NSgPqnL8w3ulTXbGKWRcDoi7J4zJC?f

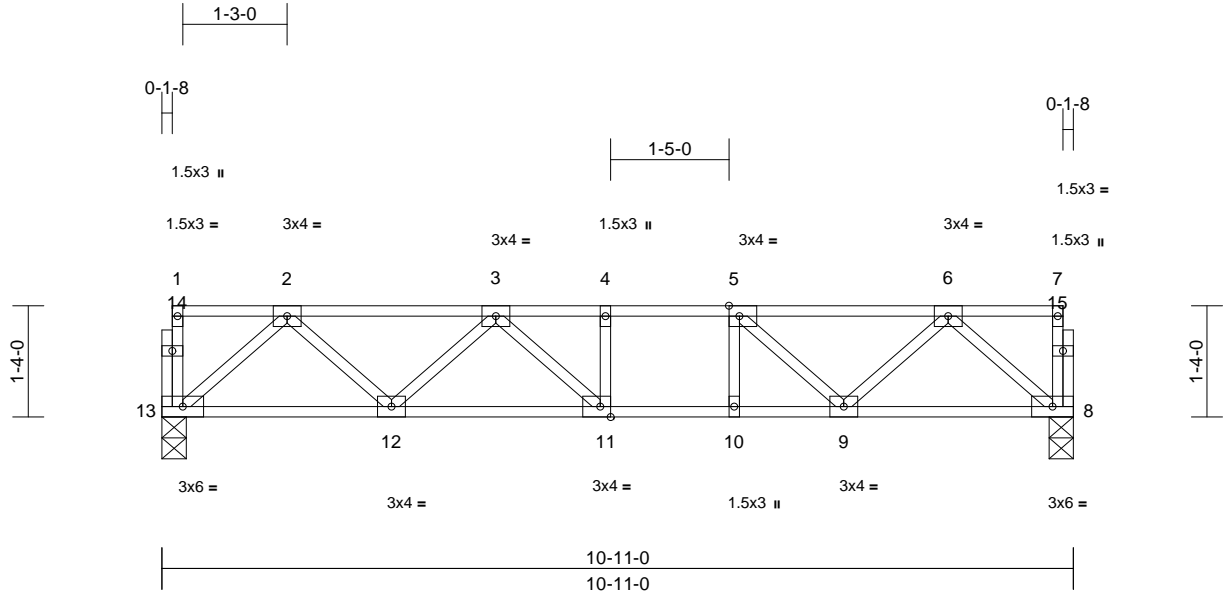

Scale = 1:27.6

Plate Offsets (X, Y): [5:0-1-8,Edge], [11:0-1-8,Edge]

Loading	(psf)	Spacing	2-0-0	CSI	DEFL	in	(loc)	l/defl	L/d	PLATES	GRIP	
TCLL	40.0	Plate Grip DOL	1.00	TC	0.38	Vert(LL)	-0.07	11-12	>999	480	MT20	244/190
TCDL	10.0	Lumber DOL	1.00	BC	0.57	Vert(CT)	-0.09	11-12	>999	360		
BCLL	0.0	Rep Stress Incr	YES	WB	0.22	Horz(CT)	0.02	8	n/a	n/a		
BCDL	5.0	Code	IRC2015/TPI2014	Matrix-S							Weight: 58 lb	FT = 20%F, 11%E

LUMBER

TOP CHORD 2x4 SP No.2(flat)
 BOT CHORD 2x4 SP No.2(flat)
 WEBS 2x4 SP No.3(flat)
 OTHERS 2x4 SP No.3(flat)

BRACING

TOP CHORD Structural wood sheathing directly applied or 6-0-0 oc purlins, except end verticals.
 BOT CHORD Rigid ceiling directly applied or 10-0-0 oc bracing.

REACTIONS (size) 8=0-3-8, 13=0-3-8

Max Grav 8=580 (LC 1), 13=580 (LC 1)

FORCES (lb) - Maximum Compression/Maximum Tension

TOP CHORD 1-13=-36/0, 7-8=-36/0, 1-2=-2/0, 2-3=-938/0,
 3-4=-1267/0, 4-5=-1267/0, 5-6=-934/0,
 6-7=-2/0

BOT CHORD 12-13=0/612, 11-12=0/1225, 10-11=0/1267,
 9-10=0/1267, 8-9=0/607

WEBS 2-13=-812/0, 2-12=0/454, 3-12=-400/0,
 6-8=-805/0, 6-9=0/455, 5-9=-460/0,
 3-11=-86/249, 4-11=109/0, 5-10=-45/116

NOTES

- 1) Unbalanced floor live loads have been considered for this design.
- 2) All bearings are assumed to be SP No.2 crushing capacity of 565 psi.
- 3) This truss is designed in accordance with the 2015 International Residential Code sections R502.11.1 and R802.10.2 and referenced standard ANSI/TPI 1.
- 4) Recommend 2x6 strongbacks, on edge, spaced at 10-00-00 oc and fastened to each truss with 3-10d (0.131" X 3") nails. Strongbacks to be attached to walls at their outer ends or restrained by other means.

LOAD CASE(S) Standard



February 26, 2024

WARNING - Verify design parameters and READ NOTES ON THIS AND INCLUDED MITEK REFERENCE PAGE MII-7473 rev. 1/2/2023 BEFORE USE.

Design valid for use only with MiTek® connectors. This design is based only upon parameters shown, and is for an individual building component, not a truss system. Before use, the building designer must verify the applicability of design parameters and properly incorporate this design into the overall building design. Bracing indicated is to prevent buckling of individual truss web and/or chord members only. Additional temporary and permanent bracing is always required for stability and to prevent collapse with possible personal injury and property damage. For general guidance regarding the fabrication, storage, delivery, erection and bracing of trusses and truss systems, see **ANSI/TPI1 Quality Criteria and DSB-22** available from Truss Plate Institute (www.tpinst.org) and **BCSI Building Component Safety Information** available from the Structural Building Component Association (www.sbcacomponents.com)



818 Soundside Road
 Edenton, NC 27932

Job 3894021	Truss F11	Truss Type Floor	Qty 2	Ply 1	Furr, Mayview B Job Reference (optional)	I63825705
----------------	--------------	---------------------	----------	----------	---------------------------------------------	-----------

Builders FirstSource (Sumter, SC), Sumter, SC - 29153,

Run: 8.63 S Nov 1 2023 Print: 8.630 S Nov 1 2023 MiTek Industries, Inc. Fri Feb 23 10:54:14
ID: _E9vI0UaSg1IYUp5yeDun3zPnWo-RfC?PsB70Hq3NSgPqnL8w3uITXbGkWrCDoi7J4zJC?f

Page: 1

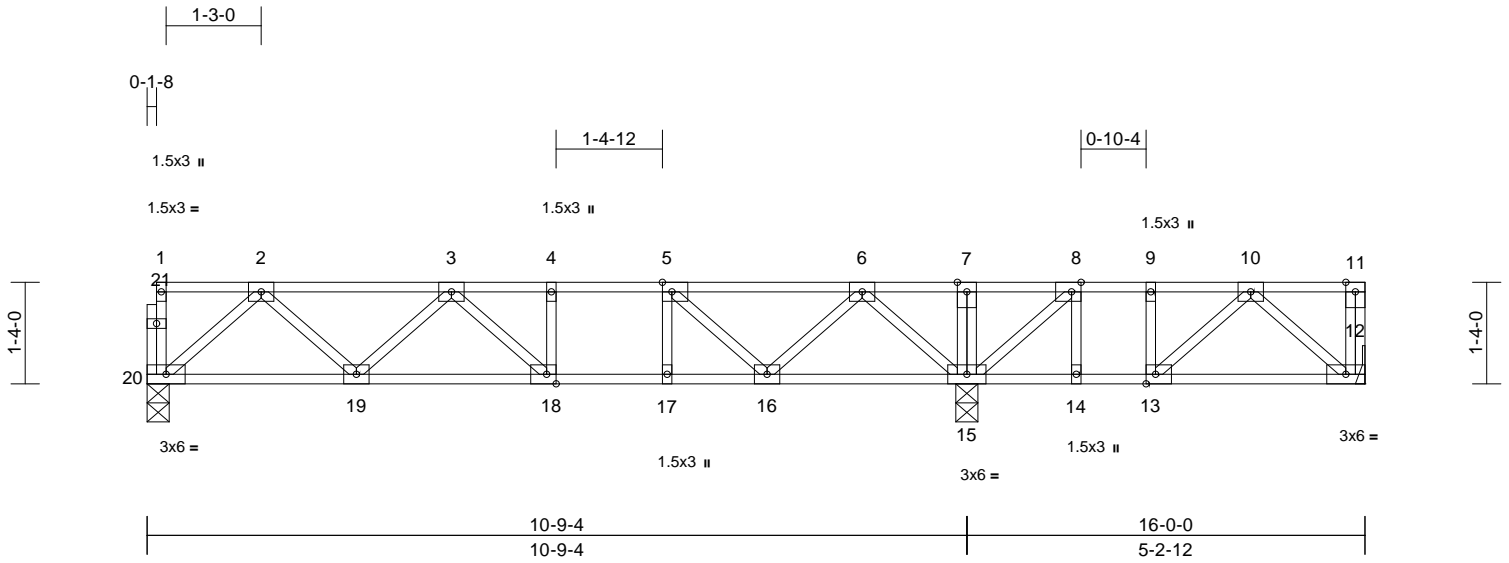

Scale = 1:30.3

Plate Offsets (X, Y): [5:0-1-8,Edge], [8:0-1-8,Edge], [13:0-1-8,Edge], [18:0-1-8,Edge]

Loading	(psf)	Spacing	2-0-0	CSI	DEFL	in	(loc)	l/defl	L/d	PLATES	GRIP	
TCLL	40.0	Plate Grip DOL	1.00	TC	0.38	Vert(LL)	-0.07	18-19	>999	480	MT20	244/190
TCDL	10.0	Lumber DOL	1.00	BC	0.57	Vert(CT)	-0.09	18-19	>999	360		
BCLL	0.0	Rep Stress Incr	YES	WB	0.24	Horz(CT)	0.02	12	n/a	n/a		
BCDL	5.0	Code	IRC2015/TPI2014	Matrix-S							Weight: 88 lb	FT = 20%F, 11%E

LUMBER
TOP CHORD 2x4 SP No.2(flat)
BOT CHORD 2x4 SP No.2(flat)
WEBS 2x4 SP No.3(flat)
OTHERS 2x4 SP No.3(flat)

BRACING
TOP CHORD Structural wood sheathing directly applied or 6-0-0 oc purlins, except end verticals.
BOT CHORD Rigid ceiling directly applied or 6-0-0 oc bracing.

REACTIONS (size) 12= Mechanical, 15=0-3-8, 20=0-3-8
Max Grav 12=277 (LC 7), 15=958 (LC 1), 20=555 (LC 10)

FORCES (lb) - Maximum Compression/Maximum Tension
TOP CHORD 1-20=-36/0, 11-12=-51/0, 1-2=-2/0, 2-3=-884/0, 3-4=-1141/0, 4-5=-1141/0, 5-6=-768/0, 6-7=0/316, 7-8=0/316, 8-9=-268/99, 9-10=-268/99, 10-11=0/0
BOT CHORD 19-20=0/583, 18-19=0/1142, 17-18=0/1141, 16-17=0/1141, 15-16=0/415, 14-15=-99/268, 13-14=-99/268, 12-13=-16/239
WEBS 7-15=-104/0, 2-20=-773/0, 2-19=0/419, 3-19=-359/0, 3-18=-91/165, 4-18=-75/1, 6-15=-845/0, 6-16=0/510, 5-16=-537/0, 5-17=-14/119, 8-15=-521/0, 10-12=-318/21, 10-13=-113/40, 9-13=-34/60, 8-14=0/89

NOTES
1) Unbalanced floor live loads have been considered for this design.
2) All plates are 3x4 MT20 unless otherwise indicated.
3) Bearings are assumed to be: Joint 20 SP No.2 crushing capacity of 565 psi, Joint 15 SP No.2 crushing capacity of 565 psi.
4) Refer to girder(s) for truss to truss connections.

- This truss is designed in accordance with the 2015 International Residential Code sections R502.11.1 and R802.10.2 and referenced standard ANSI/TPI 1.
- Recommend 2x6 strongbacks, on edge, spaced at 10-00-00 oc and fastened to each truss with 3-10d (0.131" X 3") nails. Strongbacks to be attached to walls at their outer ends or restrained by other means.
- CAUTION, Do not erect truss backwards.

LOAD CASE(S) Standard



February 26, 2024

WARNING - Verify design parameters and READ NOTES ON THIS AND INCLUDED MITEK REFERENCE PAGE MII-7473 rev. 1/2/2023 BEFORE USE.
Design valid for use only with MiTek® connectors. This design is based only upon parameters shown, and is for an individual building component, not a truss system. Before use, the building designer must verify the applicability of design parameters and properly incorporate this design into the overall building design. Bracing indicated is to prevent buckling of individual truss web and/or chord members only. Additional temporary and permanent bracing is always required for stability and to prevent collapse with possible personal injury and property damage. For general guidance regarding the fabrication, storage, delivery, erection and bracing of trusses and truss systems, see **ANSI/TPI1 Quality Criteria and DSB-22** available from Truss Plate Institute (www.tpinst.org) and **BCSI Building Component Safety Information** available from the Structural Building Component Association (www.sbcacomponents.com)



Job 3894021	Truss F12	Truss Type Floor	Qty 1	Ply 1	Furr, Mayview B Job Reference (optional)	163825706
----------------	--------------	---------------------	----------	----------	---------------------------------------------	-----------

Builders FirstSource (Sumter, SC), Sumter, SC - 29153,

Run: 8.63 S Nov 1 2023 Print: 8.630 S Nov 1 2023 MiTek Industries, Inc. Fri Feb 23 10:54:15
ID:tL1YQRZPV0EjA6BgqJluqzPnVP-RfC?PsB70Hq3NSgPqnL8w3uITXbGkWrCDoi7J4zJC?f

Page: 1

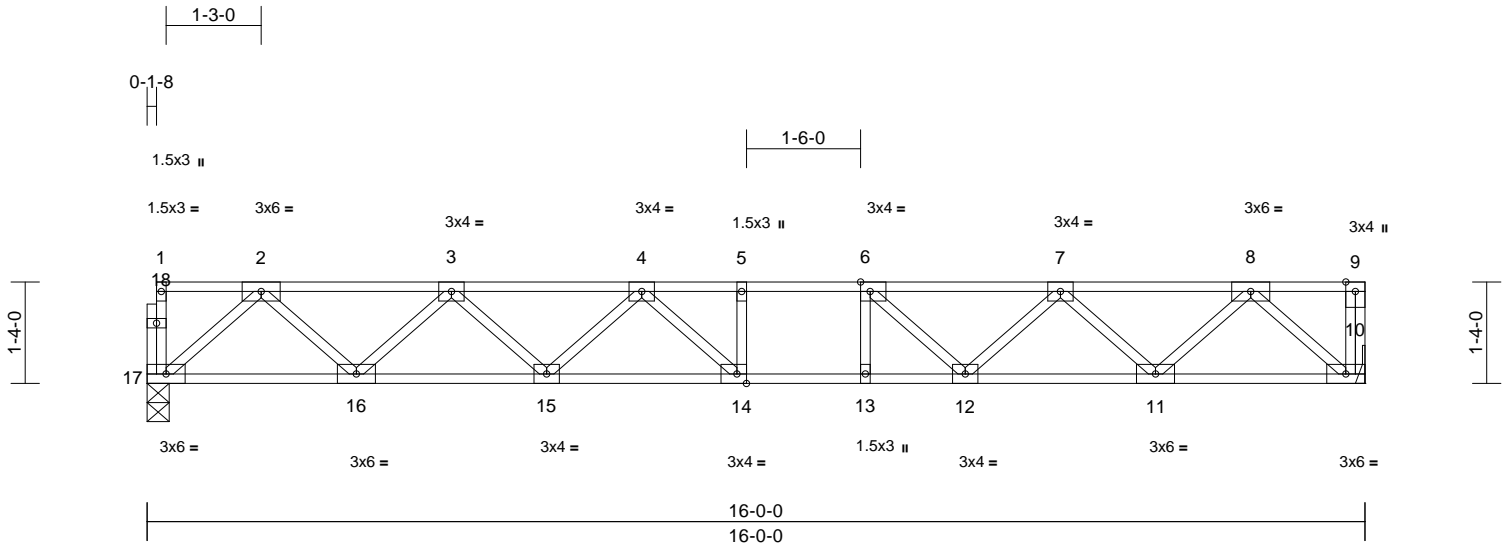

Scale = 1:30.3

Plate Offsets (X, Y): [6:0-1-8,Edge], [14:0-1-8,Edge]

Loading	(psf)	Spacing	2-0-0	CSI	DEFL	in	(loc)	l/defl	L/d	PLATES	GRIP	
TCLL	40.0	Plate Grip DOL	1.00	TC	0.55	Vert(LL)	-0.17	14-15	>999	480	MT20	244/190
TCDL	10.0	Lumber DOL	1.00	BC	1.00	Vert(CT)	-0.24	14-15	>795	360		
BCLL	0.0	Rep Stress Incr	YES	WB	0.41	Horz(CT)	0.05	10	n/a	n/a		
BCDL	5.0	Code	IRC2015/TPI2014	Matrix-S							Weight: 84 lb	FT = 20%F, 11%E

LUMBER

TOP CHORD 2x4 SP No.2(flat)
BOT CHORD 2x4 SP No.2(flat)
WEBS 2x4 SP No.3(flat)
OTHERS 2x4 SP No.3(flat)

- 6) Recommend 2x6 strongbacks, on edge, spaced at 10-00-00 oc and fastened to each truss with 3-10d (0.131" X 3") nails. Strongbacks to be attached to walls at their outer ends or restrained by other means.
7) CAUTION, Do not erect truss backwards.

LOAD CASE(S) Standard

BRACING

TOP CHORD Structural wood sheathing directly applied or 6-0-0 oc purlins, except end verticals.
BOT CHORD Rigid ceiling directly applied or 2-2-0 oc bracing.

REACTIONS (size) 10= Mechanical, 17=0-3-8
Max Grav 10=866 (LC 1), 17=860 (LC 1)

FORCES (lb) - Maximum Compression/Maximum Tension

TOP CHORD 1-17=-38/0, 9-10=-44/0, 1-2=-2/0, 2-3=-1542/0, 3-4=-2454/0, 4-5=-2787/0, 5-6=-2787/0, 6-7=-2449/0, 7-8=-1543/0, 8-9=0/0
BOT CHORD 16-17=0/924, 15-16=0/2134, 14-15=0/2737, 13-14=0/2787, 12-13=0/2787, 11-12=0/2128, 10-11=0/926
WEBS 2-17=-1227/0, 2-16=0/860, 3-16=-823/0, 3-15=0/445, 4-15=-394/0, 8-10=-1233/0, 8-11=0/859, 7-11=-813/0, 7-12=0/487, 6-12=-586/0, 4-14=-185/376, 5-14=-163/30, 6-13=-83/168

NOTES

- Unbalanced floor live loads have been considered for this design.
- All plates are 3x4 MT20 unless otherwise indicated.
- Bearings are assumed to be: Joint 17 SP No.2 crushing capacity of 565 psi.
- Refer to girder(s) for truss to truss connections.
- This truss is designed in accordance with the 2015 International Residential Code sections R502.11.1 and R802.10.2 and referenced standard ANSI/TPI 1.



February 26, 2024

WARNING - Verify design parameters and READ NOTES ON THIS AND INCLUDED MITEK REFERENCE PAGE MII-7473 rev. 1/2/2023 BEFORE USE.

Design valid for use only with MiTek® connectors. This design is based only upon parameters shown, and is for an individual building component, not a truss system. Before use, the building designer must verify the applicability of design parameters and properly incorporate this design into the overall building design. Bracing indicated is to prevent buckling of individual truss web and/or chord members only. Additional temporary and permanent bracing is always required for stability and to prevent collapse with possible personal injury and property damage. For general guidance regarding the fabrication, storage, delivery, erection and bracing of trusses and truss systems, see **ANSI/TPI1 Quality Criteria and DSB-22** available from Truss Plate Institute (www.tpinst.org) and **BCSI Building Component Safety Information** available from the Structural Building Component Association (www.sbcacomponents.com)



818 Soundside Road
Edenton, NC 27932

Job 3894021	Truss F13	Truss Type Floor Girder	Qty 1	Ply 1	Furr, Mayview B Job Reference (optional)	I63825707
----------------	--------------	----------------------------	----------	----------	---------------------------------------------	-----------

Builders FirstSource (Sumter, SC), Sumter, SC - 29153,

Run: 8.63 S Nov 1 2023 Print: 8.630 S Nov 1 2023 MiTek Industries, Inc. Fri Feb 23 10:54:15
ID: ?7rujiwDRE0PKnPyQ8sn69zPnUx-RfC?PsB70Hq3NSgPqnL8w3uITxbGKWrCDoi7J4zJC?f

Page: 1

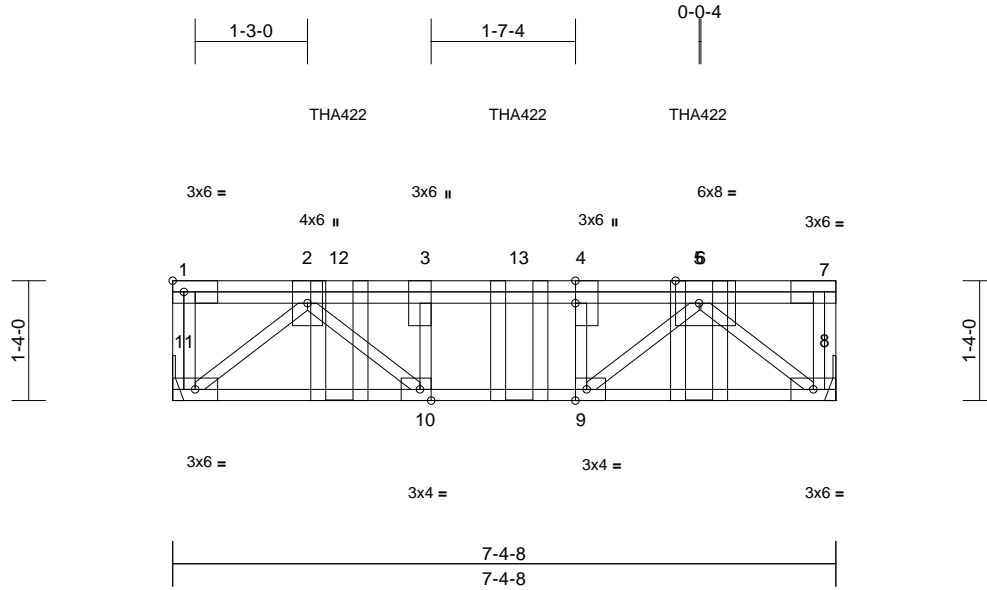

Scale = 1:25.6

Plate Offsets (X, Y): [4:0-3-0,Edge], [6:0-3-2,Edge], [9:0-1-8,Edge], [10:0-1-8,Edge]

Loading	(psf)	Spacing	2-0-0	CSI	DEFL	in	(loc)	l/defl	L/d	PLATES	GRIP	
TCLL	40.0	Plate Grip DOL	1.00	TC	0.37	Vert(LL)	-0.03	8-9	>999	480	MT20	244/190
TCDL	10.0	Lumber DOL	1.00	BC	0.55	Vert(CT)	-0.05	8-9	>999	360		
BCLL	0.0	Rep Stress Incr	NO	WB	0.44	Horz(CT)	0.01	8	n/a	n/a		
BCDL	5.0	Code	IRC2015/TPI2014	Matrix-S							Weight: 51 lb	FT = 20%F, 11%E

LUMBER

TOP CHORD 2x4 SP No.2(flat)
BOT CHORD 2x4 SP No.2(flat)
WEBS 2x4 SP No.3(flat)

BRACING

TOP CHORD Structural wood sheathing directly applied or 6-0-0 oc purlins, except end verticals.
BOT CHORD Rigid ceiling directly applied or 10-0-0 oc bracing.

REACTIONS (size) 8= Mechanical, 11= Mechanical
Max Grav 8=1228 (LC 4), 11=864 (LC 3)

FORCES (lb) - Maximum Compression/Maximum Tension

TOP CHORD 1-11=-72/0, 7-8=-66/0, 1-2=0/0, 2-3=-1594/0, 3-4=-1594/0, 4-5=-1594/0, 5-6=-1374/0, 6-7=0/0
BOT CHORD 10-11=0/944, 9-10=0/1594, 8-9=0/1374
WEBS 2-11=-1229/0, 2-10=0/931, 6-8=-1788/0, 5-9=0/313, 3-10=-563/0, 4-9=-201/0

NOTES

- Unbalanced floor live loads have been considered for this design.
- Refer to girder(s) for truss to truss connections.
- This truss is designed in accordance with the 2015 International Residential Code sections R502.11.1 and R802.10.2 and referenced standard ANSI/TPI 1.
- Recommend 2x6 strongbacks, on edge, spaced at 10-00-00 oc and fastened to each truss with 3-10d (0.131" X 3") nails. Strongbacks to be attached to walls at their outer ends or restrained by other means.
- Use Simpson Strong-Tie THA422 (6-16d Girder, 6-10d Truss) or equivalent spaced at 2-0-0 oc max. starting at 1-10-4 from the left end to 5-10-4 to connect truss(es) to back face of top chord.
- Fill all nail holes where hanger is in contact with lumber.
- In the LOAD CASE(S) section, loads applied to the face of the truss are noted as front (F) or back (B).

LOAD CASE(S) Standard

- Dead + Floor Live (balanced): Lumber Increase=1.00, Plate Increase=1.00
Uniform Loads (lb/ft)
Vert: 8-11=-10, 1-7=-100
Concentrated Loads (lb)
Vert: 5=-766 (B), 12=-177 (B), 13=-177 (B)



February 26, 2024

WARNING - Verify design parameters and READ NOTES ON THIS AND INCLUDED MITEK REFERENCE PAGE MII-7473 rev. 1/2/2023 BEFORE USE.

Design valid for use only with MiTek® connectors. This design is based only upon parameters shown, and is for an individual building component, not a truss system. Before use, the building designer must verify the applicability of design parameters and properly incorporate this design into the overall building design. Bracing indicated is to prevent buckling of individual truss web and/or chord members only. Additional temporary and permanent bracing is always required for stability and to prevent collapse with possible personal injury and property damage. For general guidance regarding the fabrication, storage, delivery, erection and bracing of trusses and truss systems, see **ANSI/TPI1 Quality Criteria and DSB-22** available from Truss Plate Institute (www.tpinst.org) and **BCSI Building Component Safety Information** available from the Structural Building Component Association (www.sbcacomponents.com)



818 Soundside Road
Edenton, NC 27932

Symbols

PLATE LOCATION AND ORIENTATION

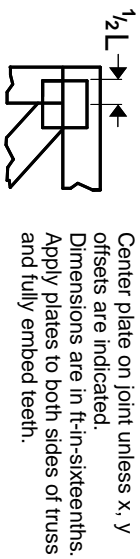

Center plate on joint unless x, y offsets are indicated. Dimensions are in ft-in-sixteenths. Apply plates to both sides of truss and fully embed teeth.

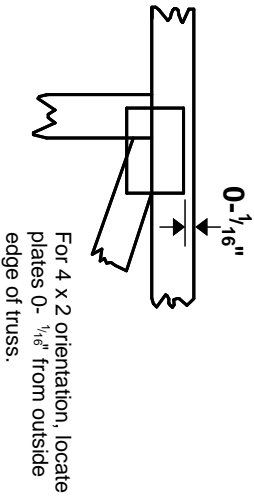

For 4 x 2 orientation, locate plates 0- 1/16\" from outside edge of truss.

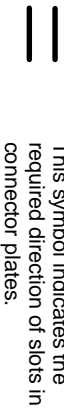

This symbol indicates the required direction of slots in connector plates.

* Plate location details available in MITek software or upon request.

PLATE SIZE

4 X 4
The first dimension is the plate width measured perpendicular to slots. Second dimension is the length parallel to slots.

LATERAL BRACING LOCATION

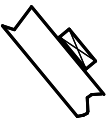

Indicated by symbol shown and/or by text in the bracing section of the output. Use T or I bracing if indicated.

BEARING

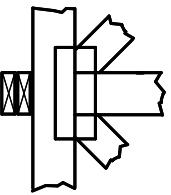

Indicates location where bearings (supports) occur. Icons vary but reaction section indicates joint number/letter where bearings occur. Min size shown is for crushing only.

Industry Standards:

ANSI/TP1: National Design Specification for Metal Plate Connected Wood Truss Construction.
DSB-22: Design Standard for Bracing.
BCSI: Building Component Safety Information, Guide to Good Practice for Handling, Installing, Restraining & Bracing of Metal Plate Connected Wood Trusses.

Numbering System

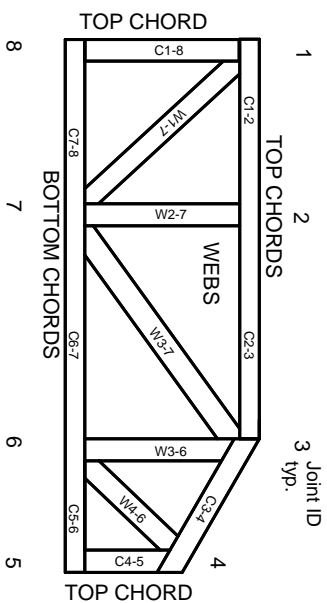

JOINTS ARE GENERALLY NUMBERED/LETTERED CLOCKWISE AROUND THE TRUSS STARTING AT THE JOINT FARTHEST TO THE LEFT.

CHORDS AND WEBS ARE IDENTIFIED BY END JOINT NUMBERS/LETTERS.

Product Code Approvals

ICC-ES Reports:

ESR-1988, ESR-2362, ESR-2685, ESR-3282
ESR-4722, ESL-1388

Design General Notes

Trusses are designed for wind loads in the plane of the truss unless otherwise shown.

Lumber design values are in accordance with ANSI/TP1 section 6.3. These truss designs rely on Lumber values established by others.

© 2023 MITek® All Rights Reserved

General Safety Notes

Failure to Follow Could Cause Property Damage or Personal Injury

1. Additional stability/bracing for truss system, e.g. diagonal or X-bracing, is always required. See BCSI.
2. Truss bracing must be designed by an engineer. For wide truss spacing, individual lateral braces themselves may require bracing, or alternative Tor I bracing should be considered.
3. Never exceed the design loading shown and never stack materials on inadequately braced trusses.
4. Provide copies of this truss design to the building designer, erection supervisor, property owner and all other interested parties.
5. Cut members to bear tightly against each other.
6. Place plates on each face of truss at each joint and embed fully. Knots and wane at joint locations are regulated by ANSI/TP1 1.
7. Design assumes trusses will be suitably protected from the environment in accord with ANSI/TP1 1.
8. Unless otherwise noted, moisture content of lumber shall not exceed 19% at time of fabrication.
9. Unless expressly noted, this design is not applicable for use with fire retardant, preservative treated, or green lumber.
10. Camber is a non-structural consideration and is the responsibility of truss fabricator. General practice is to camber for dead load deflection.
11. Plate type, size, orientation and location dimensions indicated are minimum plating requirements.
12. Lumber used shall be of the species and size, and in all respects, equal to or better than that specified.
13. Top chords must be sheathed or purlins provided at spacing indicated on design.
14. Bottom chords require lateral bracing at 10 ft. spacing, or less, if no ceiling is installed, unless otherwise noted.
15. Connections not shown are the responsibility of others.
16. Do not cut or alter truss member or plate without prior approval of an engineer.
17. Install and load vertically unless indicated otherwise.
18. Use of green or treated lumber may pose unacceptable environmental, health or performance risks. Consult with project engineer before use.
19. Review all portions of this design (front, back, words and pictures) before use. Reviewing pictures alone is not sufficient.
20. Design assumes manufacture in accordance with ANSI/TP1 Quality Criteria.
21. The design does not take into account any dynamic or other loads other than those expressly stated.

MITek

ENGINEERING BY
TRENGO
A MITek Affiliate

MITek Engineering Reference Sheet: MIL-7473 rev. 1/2/2023