

Central Carolina Soil Consulting, PLLC
1900 South Main Street, Suite 110, Wake Forest, NC 27587
Office Number: 919-569-6704

Acknowledgment of Subsurface wastewater evaluation and septic design by Central Carolina Soil Consulting, PLLC. for Cotton Farms, Lot 58 (Parcel PIN: 0643-27-3562), for issuance of an IP and CA.

For Improvement Permit (IP) issuance:

"The LSS/LG evaluation(s) attached to this application is to be used to issue an Improvement Permit in accordance with G.S. 130A-335(a2) and (a3)."

For Construction Authorization (CA) issuance:

"The plans or evaluations attached to this application are to be used to issue a Construction Authorization in accordance with G.S. 130A-335(a2), (a5) and (a6)."

The LSS evaluation attached to this application was used to produce and design a subsurface wastewater septic system for permitting to obtain an IP and CA in accordance G.S. 130A-335(a2), (a3), (a5) and (a6).

Owner:

Hakyon Homes, LLC

Owner's representative:

[Signature]

Date:

10/26/23



Permit/File #: _____

CONSTRUCTION AUTHORIZATION FOR G.S. 130A-335(a2)

County: Harnett

Pre-Construction Conference Required: Yes No

PIN/Lot Identifier: 0643-27-3562

Issued To: Halcyon Homes, LLC

Property Location: 22 Datton Court, Fuquay-Varina, NC 27526 (Cotton Farms, Lot 58)

AOWE/PE Plans/Evaluations Provided: Yes No If yes, name and license number of AOWE/PE: Jason Hall, AOWE #10004E

Facility Type: Single-Family Dwelling, 4-Bedroom

Number of bedrooms: 4 Number of Occupants: ≤8 Other: _____

New Expansion Repair System Relocation Change of Use

Basement? Yes No Basement Fixtures? Yes No

Crawl Space? Yes No Slab Foundation? Yes No

Type of Wastewater System* IIIbg, accepted (25% reduction) (Initial) IIIbe, PPBPS (vertical) (Repair)

**Please include system classification for proposed wastewater system types in accordance with Rule .1301 Table XXXII*

Design Daily Flow: 480 GPD Wastewater Strength: Domestic High Strength Industrial Process WW

Session Law 2014-120 Section 53, Engineering Design Utilizing Low-flow Fixtures and Low-flow Technologies? Yes No
(if yes, please provide engineering documentation)

Effluent Standard: DSE HSE NSF/ANSI 40 TS-I TS-II RCW

Type of Water Supply: Private well Public well Shared well Municipal Supply Spring Other: _____

Installation Requirements/Conditions

Septic Tank Size: 1200 gallons Total Trench/Bed Length: 250 feet Trench/Bed Spacing: 9 feet on center

Trench/Bed Width: 36 inches LTAR: 0.5 gpd/ft² Usable Depth to LC (Initial)*: 44" ^xLimiting condition

Additional Soil Cover: 0 inches Slope Corrected Maximum Trench/Bed Depth*: 28" inches ^{*} Measured on the downhill side of the trench

Pump Tank Size (if applicable): 1200 gallons Requires more than 1 pump? Yes No

Pump Requirements: 14.76 ft. TDH vs. 26.81 GPM Grease Trap Size (if applicable): _____ gallons

Distribution Method: Serial D-Box or Parallel Pressure Manifold(s) LPP Other: _____

Artificial Drainage Required: Yes No If yes, please specify details: _____

Legal Agreements *(If the answer is "Yes" to any type of legal agreements, please attach a copy of the agreement.)*

Multi-party Agreement Required [.0204(g)]: Yes No Declaration of Restrictive Covenants: Yes No

Easement, Right-of-Way, or Encroachment Agreement Required [.0301(b)]: Yes No

Management Entity Required: Yes No Minimum O&M Requirements: _____

Permit conditions:

The requirements of 15A NCAC 18E are incorporated by reference into this permit and shall be met. Systems shall be installed in accordance with the attached site sketch. ***This Construction Authorization is subject to revocation if the site plan, plat, or the intended use changes.*** The Construction Authorization shall not be affected by a change in ownership of the site. This Construction Authorization is subject to compliance with the provisions of 15A NCAC 18E, or 15A NCAC 18A .1900, as applicable, and to the conditions of this permit.

AOWE/PE Print Name: Jason Hall

AOWE/PE Signature: *Jason Hall*

Date: 05-06-2024

This AOWE/PE submittal is pursuant to and meets the requirements of G.S. 130A-335(a2) and (a5)

See attached site sketch



This Section for Local Health Department Use Only

Initial submittal received: _____ by _____
Date Initials

G.S. 130A-335(a5) states the following:

When an applicant for a Construction Authorization, or an Improvement Permit and Construction Authorization together, submits a Construction Authorization, or an Improvement Permit and Construction Authorization application together, the permit fee charged by the local health department, the common form developed by the Department, and any necessary signed and sealed plans or evaluations conducted by a person licensed pursuant to Chapter 89C of the General Statutes as a licensed engineer or a person certified pursuant to Article 5 of Chapter 90A of the General Statutes as an Authorized On-Site Wastewater Evaluator, the local health department shall, within five business days of receiving the application, conduct a completeness review of the submittal. A determination of completeness means that the Construction Authorization or Improvement Permit and Construction Authorization includes all of the required components. If the local health department determines that the Construction Authorization or Improvement Permit and Construction Authorization is incomplete, the local health department shall notify the applicant of the components needed to complete the Construction Authorization or Improvement Permit and Construction Authorization. The applicant may submit additional information to the local health department to cure the deficiencies in the Construction Authorization or Improvement Permit and Construction Authorization. The local health department shall make a final determination as to whether the Construction Authorization or Improvement Permit and Construction Authorization is complete within five business days after the local health department receives the additional information from the applicant. If the local health department fails to act within any period set out in this subsection, the applicant may treat the failure to act as a determination of completeness. The applicant may apply for the building permit for the project upon the decision of completeness of the Construction Authorization or Improvement Permit and Construction Authorization by the local health department or if the local health department fails to act within five business days. The Authorized On-Site Wastewater Evaluator or licensed engineer submitting the evaluation pursuant to this subsection may request that the local health department revoke or suspend the Construction Authorization or Improvement Permit and Construction Authorization for cause. Upon written request of the Authorized On-Site Wastewater Evaluator or licensed engineer, the local health department shall suspend or revoke the Construction Authorization or Improvement Permit and Construction Authorization pursuant to G.S. 130A-23. The Department shall develop a common form for use as the Construction Authorization.

The review for completeness of this Construction Authorization was conducted in accordance with G.S. 130A-335(a5). This

Construction Authorization is determined to be:

Incomplete (If box is checked, information in this section is required.)

The following items are missing: _____

Copies of this were sent to the AOWE/PE and the Applicant on _____
Date

State Authorized Agent: _____ Date: _____

Complete

State Authorized Agent: _____ Date of Issuance: _____

This Construction Authorization is issued pursuant to G.S. 130A-335(a2) and (a5) using the signed and sealed plans or evaluations attached here. This Construction Authorization is subject to revocation if the site plan, plat, or the intended use changes. The Construction Authorization shall not be affected by a change in ownership of the site. This Construction Authorization is subject to compliance with the provisions of the Laws and Rules for Sewage Treatment and Disposal and to the conditions of this permit.

The Department, the Department's authorized agents, and the local health departments shall be discharged and released from any liabilities, duties, and responsibilities imposed by statute or in common law from any claim arising out of or attributed to plans, evaluations, preconstruction conference findings, submittals, or actions from a person licensed pursuant to Chapter 89C of the General Statutes as a licensed engineer or a person certified pursuant to Article 5 of Chapter 90A of the General Statutes as an Authorized On-Site Wastewater Evaluator in GS 130A-335(a2), (a5), and (a7). The Department, the Department's authorized agents, and the local health departments shall be responsible and bear liability for their actions and evaluations and other obligations under State law or rule, including the issuance of the operations permit pursuant to GS 130A-337.

Construction Authorization Expiration Date: _____

See attached site sketch

Re-submittal of Construction Authorization

LHD USE ONLY: This CA resubmittal received: _____ by _____

Date *Initials*

The following items are being resubmitted pursuant to G.S. 130A-335(a5) for issuance of the Construction Authorization:

I, _____ hereby attest that the information required to be included with this re-submittal
Authorized Onsite Wastewater Evaluator (Print Name)
 is accurate and complete to the best of my knowledge and that the proposed Construction Authorization meets all applicable federal, State, and local laws, regulations, rules, and ordinances.

Signature of Authorized On-Site Wastewater Evaluator *Date*

The section below is for Local Health Department use after submittal of items noted as missing above.

LHD Follow-up Completeness Review of Construction Authorization

The review for completeness of this Construction Authorization re-submittal was conducted in accordance with G.S. 130A-335(a5). This Construction Authorization is determined to be:

Incomplete (If box is checked, information in this section is required.)

The following items are missing:

Copies of this were sent to the AOWE/PE and the Applicant on _____
Date

State Authorized Agent: _____ Date: _____

Complete

State Authorized Agent: _____ Date: _____

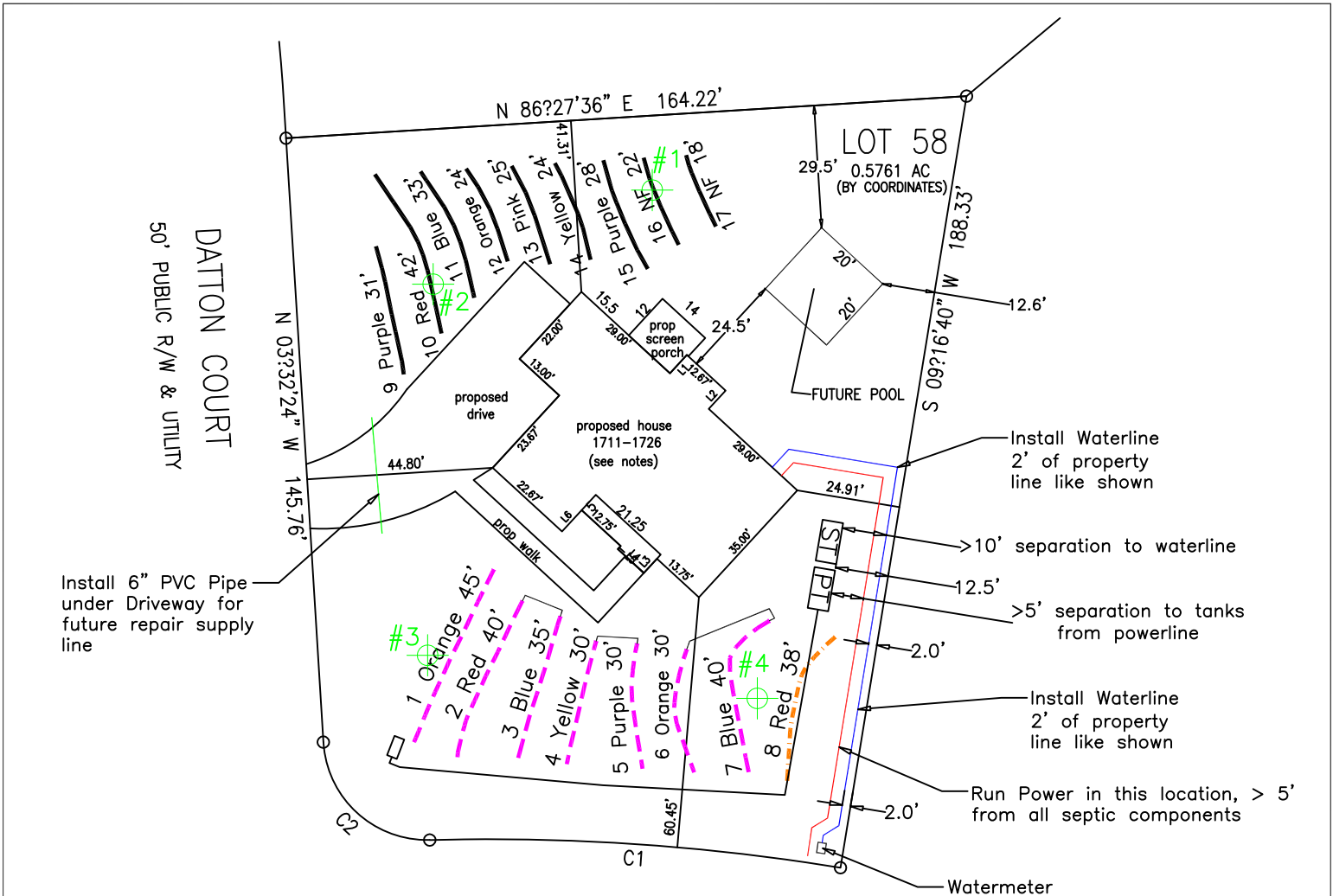

DEER TRAIL LANE
50' PUBLIC R/W & UTILITY

Install 6" PVC Pipe under Driveway for future repair supply line

Install Waterline 2' of property line like shown

10' separation to waterline

>5' separation to tanks from powerline

Install Waterline 2' of property line like shown

Run Power in this location, > 5' from all septic components

- *Keep tanks and drain lines 10' from property lines.
- *Not a survey.
- *Not a guarantee of a septic permit.
- *Keep supply lines >5' from property lines.
- *Some lines are flagged longer in the field than lengths indicate.
- *No grading septic area.
- *No adding soil within septic area
- *No rutting-up septic area
- *No cuts of >2' within 15' of septic areas

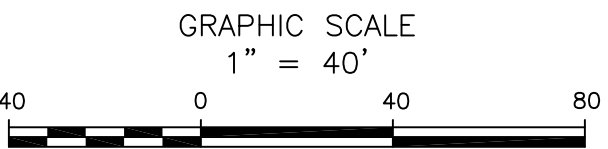

System: ---
 Repair: ---
 Not Used: ---
 [ST] = 1200 gallon tanks
 [PT] = tanks
 ⊕ #2 = profile description locations

System: Pressure Manifold
 Lines: 1-7, (250')
 Accepted Status System (25% reduction)
 0.5 Soil LTAR
 28" Trench Bottom

Repair: Pressure Manifold
 Lines: 9-17, (247')
 T&J Panel Block System (Vertical)
 0.35 Soil LTAR
 28" Trench Bottom



Central Carolina Soil Consulting, PLLC
 1900 South Main Street, Suite 110
 Wake Forest, North Carolina 27587
 Phone (919)569-6704 Fax (919)569-6703

4-Bedroom Septic Layout
 Lot 58, Cotton Farms Subdivision
 Harnett County, North Carolina

Job#: 4722
Drawn By: JR
Date: 10/25/2023
Revision: 05/06/2024

Pressure Manifold
Septic System Design

for

Cotton Farms, Lot 58
Harnett County, North Carolina

Designed by:

James Rice
Central Carolina Soil Consulting, PLLC
Wake Forest, North Carolina

05/06/2024

Cotton Farms, Lot 58
Layout/Design Specifications

Facility Type:	Single-Family Dwelling
# of Bedrooms:	4
Daily Flow:	480 gal/day
L.T.A.R.:	0.5 gal/day/sq.ft
Trench Depth:	28 in max on the downhill side of the trench
Trench Width:	36 in
Stone Depth:	EZ-FLOW in
Manifold Length:	42 in
Manifold Diameter:	4 in sch 80pvc
Supply Line Length:	146 ft
Supply Line Diameter:	2 in sch 40pvc
Supply Line Volume:	25.40 gallons
Friction Loss + Fitting Loss:	3.66 ft(supply line length + 70' for fittings in pump tank)
Design Head:	2 ft
Elevation Head:	9.10 ft
Total Head:	14.76 ft
Dose Volume:	121.88 gals
% of Pipe Vol.:	0.75
Drawdown:	5.67 in @ 21.5 gal/in
Pump Run Time:	4.55 Mins
Control Panel:	SJE Rhombus Model112 control panel (or approved equivalent)
Pump:	Zoeller M98 Flow-Mate (or approved equivalent)
Septic Tank Effluent Filter:	Polylok PL-68 residential effluent filter (or approved equivalent)
Septic Tank:	Brantley 1,250 Gallon ST 323
Pump Tank:	Brantley 1,300 Gallon PT 2124

**Cotton Farms, Lot 58
Initial System TAP CHART**

Bench Mark:	is = 100.00		Location of BM:		Elevation Head:		9.10		
Pump tank elev.	5.9	94.10	Pump elev.	88.70		Manifold elevation:		97.80	
line	color	rod read	Elevation	length	hole size	flow/tap	gal/day	trench area	LINE LTAR
1	Orange	3.20	96.80	45	1/2in SCH 80	5.48	98.11	135	0.7268
2 & 3	Red/Blue	3.70	96.30	75	1/2in SCH 40	7.11	127.30	225	0.5658
4 & 5	Yell/Purp	4.50	95.50	60	1/2in SCH 40	7.11	127.30	180	0.7072
6 & 7	Oran/Blue	5.40	94.60	70	1/2in SCH 40	7.11	127.30	210	0.6062

	total	feet =	250	gal/min =	26.81	LTAR =	0.5000
						LTAR + %5	0.5250
% of Dose Volume	75	Des. Flow	480	(ltar W/ INOV)			0.6667
Dose Volume	121.88	Pump Run=	17.90	(ltar W/ INOV + 5%)			0.7000
Dose Pump Time	4.55	Tank Gal/IN	21.5				
Drawdown in Inches	5.67						

**Cotton Farms, Lot 58
T&J Panel Block Repair System, TAP CHART**

Bench Mark:	is = 100.00		Location of BM:		Elevation Head:		8.40					
Pump tank elev.	5.9	94.10	Pump elev.	88.70		Manifold elevation:		97.10				
line	color	rod read	Elevation	length	hole size	flow/tap	gal/day	trench area	LINE LTAR	# of Panels	Spacing of Panels (in)	Feet of 2in PVC
9	Purple	3.90	96.10	31	1/2in SCH 80	5.48	66.76	93	0.7179	7	6.3	12
10	Red	4.10	95.90	42	1/2in SCH 40	7.11	86.62	126	0.6875	10	4	18
11	Blue	4.80	95.20	33	1/2in SCH 80	5.48	66.76	99	0.6744	8	3.1	14
12 & 13	Orange	5.10	94.90	49	1/2in SCH 40	7.11	86.62	147	0.5892	11	6.8	20
14 & 15	Pink/Yell	5.60	94.40	52	1/2in SCH 40	7.11	86.62	156	0.5553	12	5.5	22
16 & 17	Purp/NF	6.50	93.50	40	1/2in SCH 40	7.11	86.62	120	0.7218	9	6.6	16

	total feet =	247	gal/min =	39.4	Total Number of Panels:	57
					T&J Panel Block Orientation:	Vertical
					LTAR =	0.3500
% of Dose Vol.	0	Des. Flow	480	LTAR + %5	0.3675	
Dose Volume	205.20	Pump Run=	12.18	(ltar W/ INOV)	0.7000	
Dose Pump Time	5.21	Tank Gal/IN	21.5	(ltar W/ INOV + 5%)	0.7350	
Drawdown in Inches	9.54					
		Backfill Sand Needed:	42 tons	Total Footage of 2in PVC:	102	
		backfill sand needed +5%:	44.1 tons			

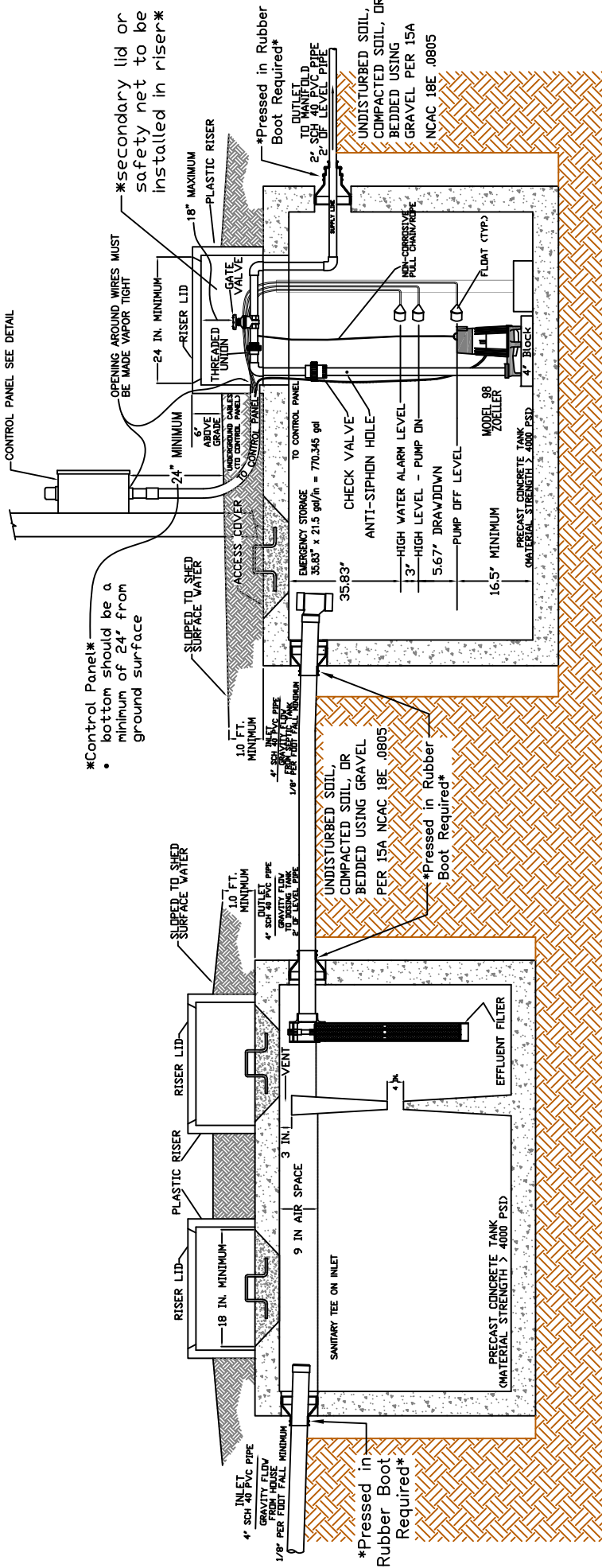

Brantley 1200 GAL SEPTIC TANK SCHEMATIC
NOT TO SCALE

Brantley 1300 GAL PUMP TANK SCHEMATIC
NOT TO SCALE

NOTES:

- ALL TANKS SHALL BE LEAK TESTED (IN OCCURANCE TO RULE 15A NCAC 18E .0805) WHEN INSTALLED UNDER THE FOLLOWING CONDITIONS
 - when a Soil Wetness Condition (SWC) is present within four feet of the elevation of the top of a mid-seam pump tank;
 - with advanced pretreatment when required in the RWTS or PIA Approval;
 - when required in the approved plans and specifications for a wastewater system designed by a PE;
 - as required by the authorized agent based upon site or system specific conditions, such as misaligned seams, exposed reinforcement, or damage observed that may have occurred during transport or installation.
- ALL TANKS MUST BE APPROVED FOR USE BY THE NORTH CAROLINA DEPARTMENT OF ENVIRONMENTAL HEALTH (DEH).
- INVERTS SHOWN ARE APPROXIMATE. THE INSTALLER SHALL FIELD CONFIRM PRIOR TO CONSTRUCTION.
- ALL HARDWARE INSTALLED INSIDE OF TANKS SHALL BE OF STAINLESS STEEL.
- TANK DIMENSIONS VARY BY MANUFACTURER.
- DRAWDOWN WILL VARY WITH TANK DIMENSIONS.
- NO ELECTRICAL SPLICES SHALL BE MADE INSIDE THE PUMP TANK.

ALL tank openings (2 for septic tank, 1 for pump tank) shall have a secondary lid or safety net installed

- THE CONTROL PANEL SHALL BE HOUSED IN A NEMA 4X WEATHERPROOF HOUSING.
- THE CONTROL PANEL SHALL INCLUDE:
 - AN INDEPENDENT OVERLOAD PROTECTION, IF NOT INTEGRAL WITH THE PUMP MOTOR
 - CIRCUIT BREAKER(S)
 - A MOTOR CONTRACTOR OR A SOLID-STATE RELAY
 - A HAND-OFF-AUTOMATIC (H-O-A) SWITCH
 - A PUMP RUN LIGHT
 - AN ELAPSED TIME METER
 - AN EVENT COUNTER

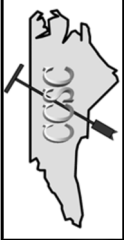

Central Carolina Soil Consulting, PLLC
1900 South Main Street, Suite 110
Wake Forest, North Carolina 27587
Phone (919)569-6704 Fax (919)569-6703

Septic and Pump Tank Details
Cotton Farms Subdivision, Lot 58
Harnett County, North Carolina

Job# : 4722
Drawn By : JR
Date : 05/06/2024

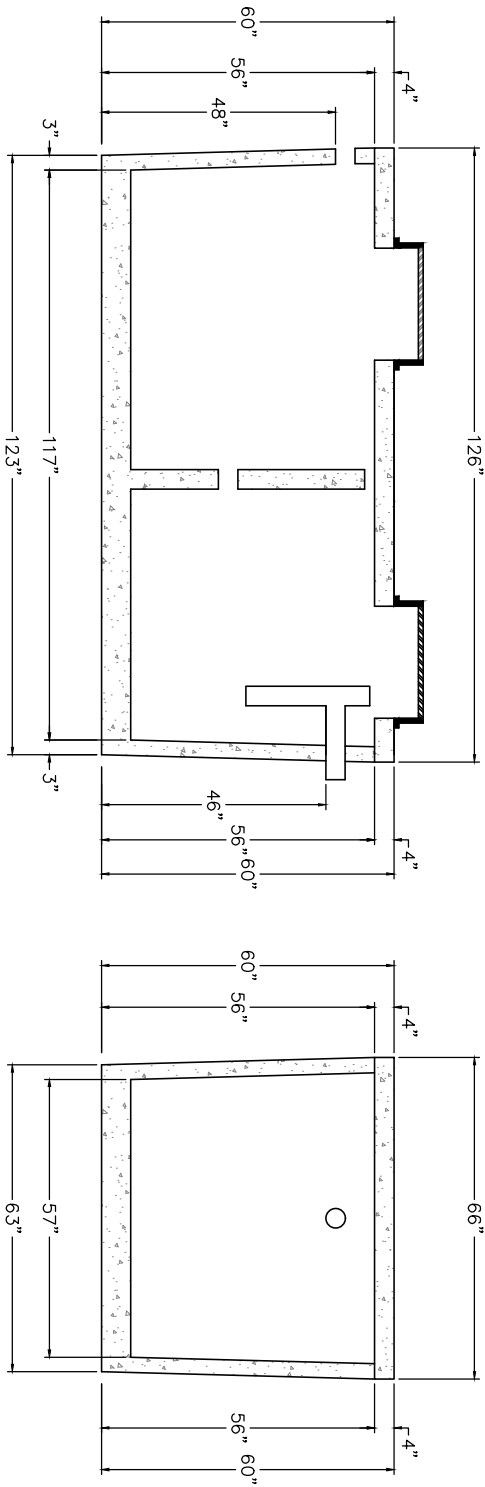

1,250 ST 323
NTS

NON TRAFFIC BEARING

DAVID BRANTLEY & SONS
37 Pine Ridge Rd.
Zebulon, NC 27597
Office 252-478-3721
Fax 919-573-0443
installer@gmail.com

PREPARED FOR : David Brantley & Sons
37 Pine Ridge Rd.
Zebulon, NC 27597

DATE : April 11, 2014

CONTACT:
CORY BRANTLEY

REVISION NO.

Original Submittal

Revision 1

Revision 2

Revision 3

Master Set

DATE

April 11, 2014

BRANTLEY TANK MODEL
1,250 ST 323

SHEET NUMBER

1 of 1

PL-68 Filter and Tee

PL-68 is much more than just an effluent filter. The housing can also be used as an inlet baffle (tee) or an outlet baffle. The housing is designed to accept Polylok’s snap in gas deflector to deflect gas bubbles away from the tee and to keep the solids in the tank.

Features:

- Offers 68 linear feet of 1/16” filter slots, which significantly extends time between cleaning.
- Accepts 3/4” PVC handle.
- Locks in any 360° position when used with PL-68 Tee.
- PL-68 Housing can be used as an inlet or outlet tee.
- Gasket prevents bypass.

PL-68 Installation:

Ideal for residential waste flows up to 800 gallons per day (GPD). Easily installs in any new or existing 4” outlet tee.

1. Locate the outlet of the septic tank.
2. Remove the tank cover and pump tank if necessary.
3. Glue the filter housing to the outlet pipe, or use a Polylok Extend & Lok if not enough pipe exists.
4. Insert the PL-68 filter into tee.
5. Replace and secure the septic tank cover.

PL-68 Maintenance:

The PL-68 Effluent Filter will operate efficiently for several years under normal conditions before requiring cleaning. It is recommended that the filter be cleaned every time the tank is pumped, or at least every three years.

1. Do not use plumbing when filter is removed.
2. Pull PL-68 out of the tee.
3. Hose off filter over the septic tank. Make sure all solids fall back into septic tank.
4. Insert filter back into tee/housing.

Related Products:

PL-68 Filter Concrete Baffle
 Extend & Lok™

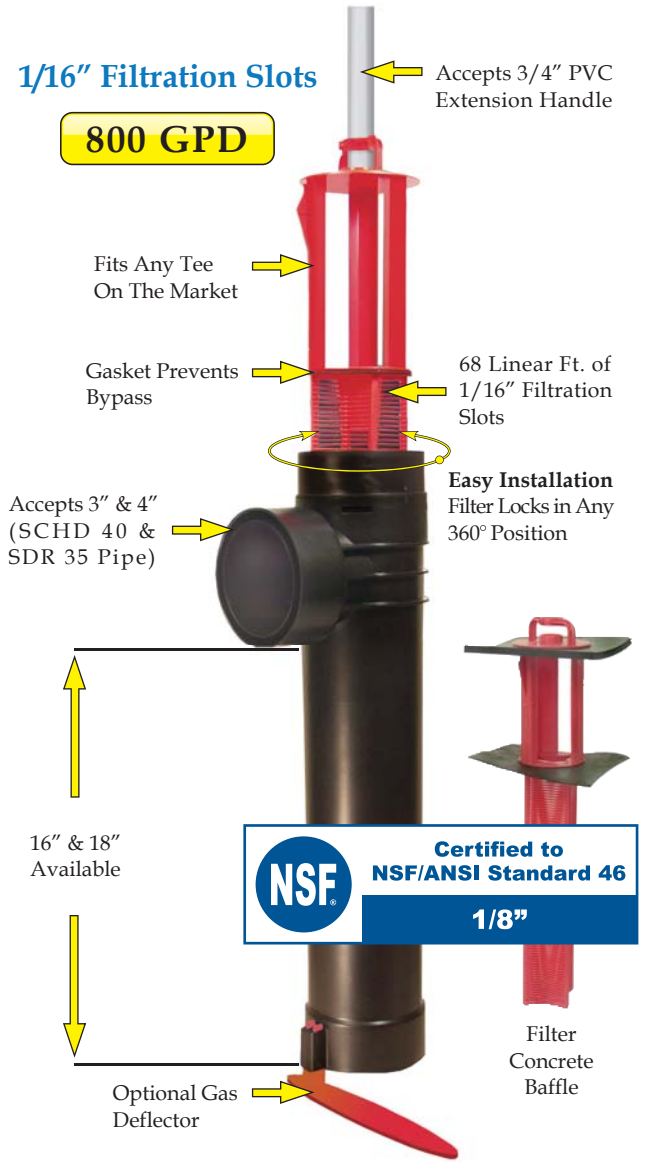

Extend & Lok™
 Easily installs into existing tanks.



Spacer Bushing
 4” SCHD 40 to SDR 35



Spacer Bushing
 4” SCHD 40 to 110mm Pipe



2” Extender

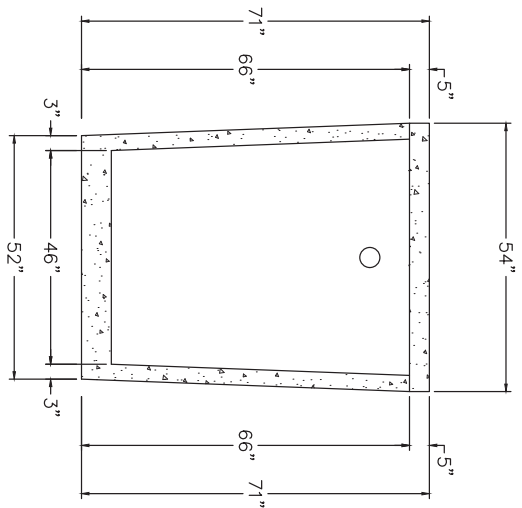
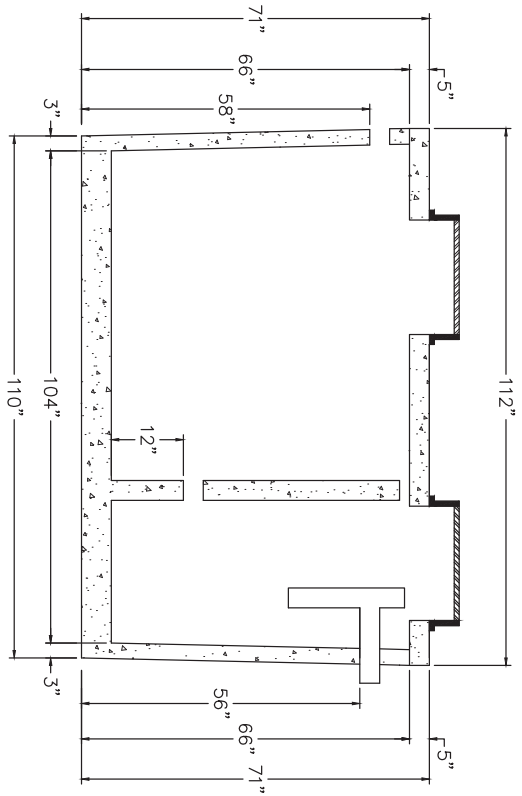

1,300 PT-2124
NTS

NON TRAFFIC BEARING

DAVID BRANTLEY & SONS

37 Pine Ridge Rd.
Zebulon, NC 27597
Office 252-478-3721
Fax 919-573-0443

tinstaller@gmail.com

PREPARED FOR : David Brantley & Sons
37 Pine Ridge Rd.
Zebulon, NC 27597

DATE : September 14, 2017

CONTACT:
CORY BRANTLEY

REVISION NO.

Original Submittal

Revision 1

Revision 2

Revision 3

Master Set

DATE

SEPT. 14, 2017

BRANTLEY TANK MODEL

1,300 PT 2124

SHEET NUMBER

1 of 1

MODEL 112 Control Panel

Single phase, simplex motor contactor control.

The Model 112 control panel provides a reliable means of controlling one 120, 208, or 240 VAC single phase pump in pump chambers, sump pump basins, irrigation systems and lift stations. Two control switches activate a magnetic motor contactor to turn the pump on and off. If an alarm condition occurs, an additional alarm switch activates the audio/visual alarm system.

PANEL COMPONENTS

1. **Enclosure** measures 8 x 8 x 4 inches (20.32 X 20.32 X 10.16 cm). Choice of NEMA 1 (steel for indoor use), or NEMA 4X (ultraviolet stabilized thermoplastic with removable flanges for outdoor or indoor use).
* Options selected may increase enclosure size and change component layout.
2. **Magnetic Motor Contactor** controls pump by switching electrical lines.
3. **HOA Switch** for manual pump control (mounted on circuit board).
4. **Green Pump Run Indicator Light** (mounted on circuit board).
5. **Float Switch Terminal Block** (mounted on circuit board).
6. **Alarm and Control Fuses** (mounted on circuit board).
7. **Alarm and Control Power Indicators** (mounted on circuit board).
8. **Pump Input Power and Pump Connection Terminal Block**
9. **Ground Lug**
10. **Terminal Block Installation Label**
11. **Circuit Breaker** (optional) provides pump disconnect and branch circuit protection.

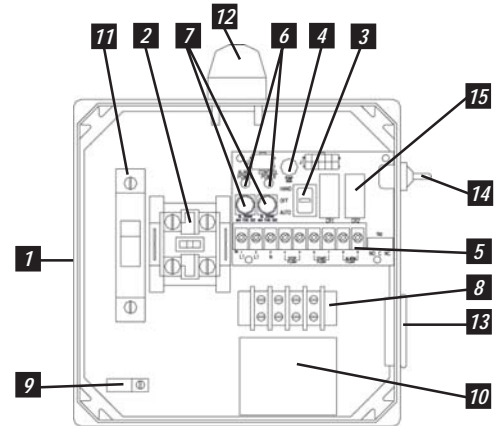

Model Shown 1121W914X

STANDARD ALARM PACKAGE

12. **Red Alarm Beacon** provides 360° visual check of alarm condition.
Note: NEMA 1 style utilizes a door mounted indicator in lieu of a beacon.
13. **Alarm Horn** provides audio warning of alarm condition (83 to 85 decibel rating).
Note: NEMA 1 style utilizes an internally mounted buzzer in lieu of horn.
14. **Exterior Alarm Test/Normal/Silence Switch** allows horn and light to be tested and horn to be silenced in an alarm condition. Alarm automatically resets once alarm condition has been cleared.
15. **Horn Silence Relay** (mounted on circuit board).

NOTE: other options available.

FEATURES

- Entire control system (panel and switches) is UL Listed to meet and/or exceed industry safety standards
- Dual safety certification for the United States and Canada
- Standard package includes three 20' Sensor Float® control switches
- Complete with step-by-step installation instructions
- Three-year limited warranty



SJE
Rhombus
CONTROLS

PO Box 1708, Detroit Lakes, MN 56502

1-888-DIAL-SJE • 1-218-847-1317

1-218-847-4617 Fax

email: sje@sjerhombus.com

www.sjerhombus.com

SEE BACKSIDE FOR COMPLETE LISTING OF AVAILABLE OPTIONS.

112 **1** **W** **1** **2** **4** **H** **3A, 8A, 8C, 15A**

MODEL 112

ALARMPACKAGE

- 0 = select options or no alarm package
- 1 = alarm package (includes test/normal/silence switch, fuse, red light, horn & float)

ENCLOSURE RATING

- I = Indoor, NEMA 1 (metal)
- W = Weatherproof, NEMA 4X (engineered thermoplastic)

STARTING DEVICE

- 1 = magnetic motor contactor 120/208/240V
- 9 = magnetic motor contactor 120V only

PUMP FULL LOAD AMPS

- 0 = 0-7 FLA
- 1 = 7-15 FLA
- 2 = 15-20 FLA
- 3 = 20-30 FLA

PUMP DISCONNECTS

- 0 = no pump disconnect
- 1 = pull-out with safety deadfront in a 10"x8" enclosure
- 4 = circuit breaker 120V (select STARTING DEVICE option 9 above)
120/208/240V (select STARTING DEVICE option 1 above)

FLOAT SWITCH APPLICATION

- H or L = pump down or pump up
- X = no floats
- WITH alarm package
- WITHOUT alarm package

OPTIONS *Listed below*



ENCLOSURE UPSIZE - If you selected 3 or more of the ★ options, or one ★★ option, a one-time enclosure upsize fee would apply.

If additional features are required, call the factory for a quote on either a SJE-Rhombus Pro-Line or Engineered Custom control panel.

CODE	DESCRIPTION	CODE	DESCRIPTION
<input type="checkbox"/>	1A Red beacon only / no audio <i>(must select 1E if floats included)</i>	<input type="checkbox"/>	11C NEMA 1 alarm panel <i>must select option 6A</i>
<input type="checkbox"/>	1C Horn only / no visual <i>(must select 1E if floats included)</i>	<input type="checkbox"/>	11D NEMA 4X alarm panel <i>must select option 6A</i>
<input type="checkbox"/>	1E Alarm float	<input checked="" type="checkbox"/>	★14B Main disconnect (rotary style, mounted through door) non-fused
<input checked="" type="checkbox"/>	3A Alarm flasher	★★ <input type="checkbox"/>	0-20 FLA (total of both pumps)
<input type="checkbox"/>	★ 3B Manual alarm reset	★★ <input type="checkbox"/>	20-30 FLA (total of both pumps)
<input type="checkbox"/>	★ 4A Low level cutout <i>(select option 4D if floats included)</i>	<input checked="" type="checkbox"/>	15A Control / alarm circuit breaker <i>Does not include the circuit board as in standard.</i>
<input type="checkbox"/>	★ 4B Red low-level indicator & alarm <i>(must select 4A also)</i>	<input type="checkbox"/>	16A 10' cord in lieu of 20' <i>(per float)</i>
<input type="checkbox"/>	4D Low-level float	<input type="checkbox"/>	16B 15' cord in lieu of 20' <i>(per float)</i>
<input type="checkbox"/>	★ 5A Thermal cutout/heat sensor auto reset (for pumps w/thermal switch leads)	<input type="checkbox"/>	16C 30' cord in lieu of 20' <i>(per float)</i>
<input type="checkbox"/>	★★5E Seal failure circuit & red indicator (2 wire)	<input type="checkbox"/>	16D 40' cord in lieu of 20' <i>(per float)</i>
<input type="checkbox"/>	6A Auxiliary alarm contact, form C type	<input type="checkbox"/>	17A SJE SignalMaster® / mounting strap ● <i>(per float)</i>
<input checked="" type="checkbox"/>	★ 8A Elapsed time meter	<input type="checkbox"/>	17B SJE SignalMaster® / externally weighted ● <i>(per float)</i>
<input checked="" type="checkbox"/>	★ 8C Event (cycle) counter	<input type="checkbox"/>	17C Sensor Float® / internally weighted ▲ <i>(per float)</i>
<input type="checkbox"/>	★★9_A Pump overload specify amperage after number 9 followed by letter "A". Example: 912A = 12 amp pump.	<input type="checkbox"/>	17D Sensor Float® / externally weighted ▲ <i>(per float)</i>
★★ <input type="checkbox"/>	0-25 FLA	<input type="checkbox"/>	17E Sensor Float® Mini / pipe clamp ▲ <i>(per float)</i>
★★ <input type="checkbox"/>	25-30 FLA	<input type="checkbox"/>	17F Sensor Float® Mini / externally weighted ▲ <i>(per float)</i>
<input type="checkbox"/>	10E Lockable latch - NEMA 4X	<input type="checkbox"/>	19T TOA (Test/Off/Automatic) switch and pump run light through door mounted
<input type="checkbox"/>	10E Lockable latch - NEMA 1	<input type="checkbox"/>	19U HOA (Hand/Off/Automatic) switch and pump run light through door mounted
<input type="checkbox"/>	★10F Lightning arrester	<input type="checkbox"/>	19X Door mounted pump run indicator
<input type="checkbox"/>	★10K Anti-condensation heater	<input type="checkbox"/>	21A SJE PumpMaster® in lieu of on/off switches ●
		<input type="checkbox"/>	21B SJE PumpMaster® Plus in lieu of on/off switches ●
		<input type="checkbox"/>	21C Super Single® in lieu of on/off switches ●
		<input type="checkbox"/>	21D Double Float® in lieu of on/off switches ▲
			● Mechanically-activated ▲ Mercury-activated

SAMPLE

MODEL **112** **1** **W** **9** **1** **4** **H** **3A 8A**

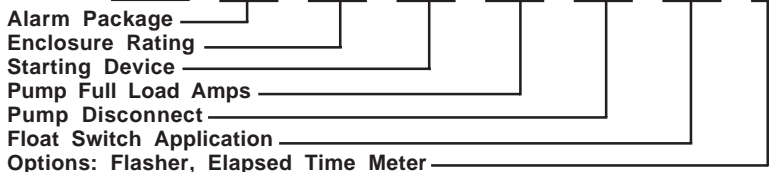



Model 98

Sump Pump

Professional Series Sump Pump Model 98 Features:

- 3-year warranty
- 2-pole mechanical switch
- 1/2 HP 115 V sump pump
- Performance up to 23' (7 m) TDH
- Flows up to 72 GPM (273 LPM)
- Cast iron switch case, motor and pump housing
- Corrosion-resistant, powder coated epoxy paint

100% factory tested



Trusted. Tested. Tough.®

zoellerpumps.com 800-928-7867
3649 Cane Run Road, Louisville, KY 40211 USA

FM3012
0520
Supersedes
0117

PRODUCT SPECIFICATIONS

MOTOR	Horse Power	1/2
	Voltage	115 or 230
	Phase	1 Ph
	Hertz	60 Hz
	RPM	1725
	Type	Permanent split capacitor
	Insulation	Class B
	Amps	4.7 - 9.4
	PUMP	Operation
Auto On/Off Points		9-1/2" (24 cm) / 3" (7.6 cm)
Discharge Size		1-1/2" NPT
Solids Handling		1/2" (13 mm) spherical solids
Cord Length		15' (5 m) standard
Cord Type		UL listed
Max. Head		23' (7 m)
Max. Flow Rate		72 GPM (273 LPM)
Max. Operating Temp.		130° F (54° C)
Cooling		Oil filled
Motor Protection		Auto reset thermal overload
MATERIALS	Cap	Cast iron
	Motor Housing	Cast iron
	Pump Housing	Cast iron
	Base	Engineered thermoplastic
	Upper Bearing	Oil-fed cast iron
	Lower Bearing	Oil-fed cast iron
	Mechanical Seals	Carbon and ceramic
	Impeller Type	Non-clogging vortex
	Impeller	Engineered plastic
	Hardware	Stainless steel
	Motor Shaft	AISI 1215 cold rolled steel
	Gasket	Neoprene

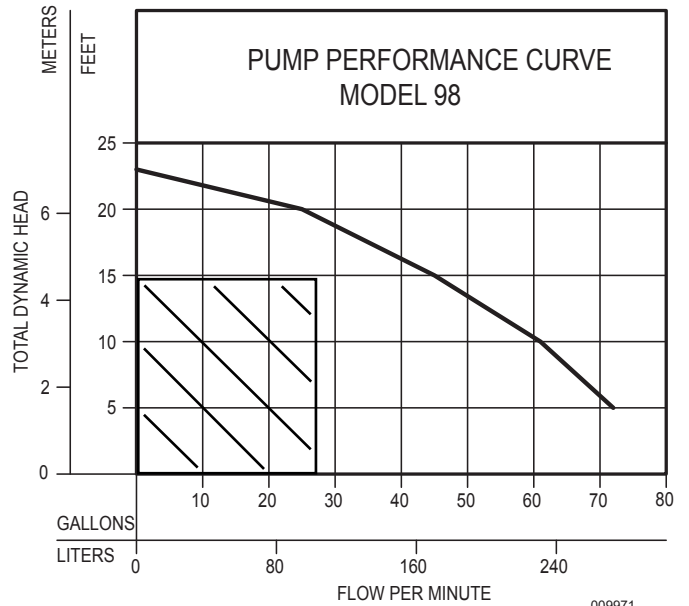
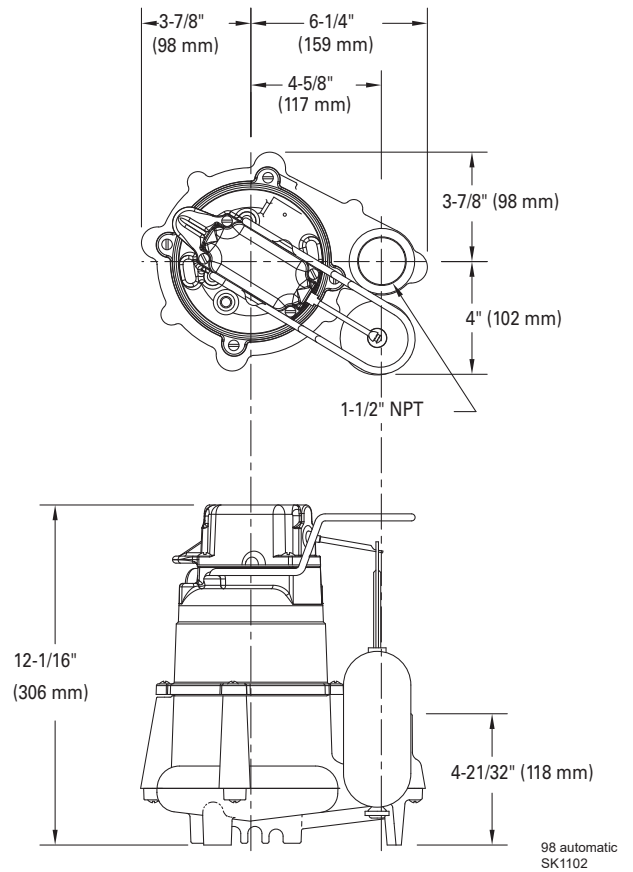



 Tested to Standard UL778 and
 Certified to CSA
 Standard C22.2 No. 108







PRESSURE MANIFOLD DETAILS TOP VIEW

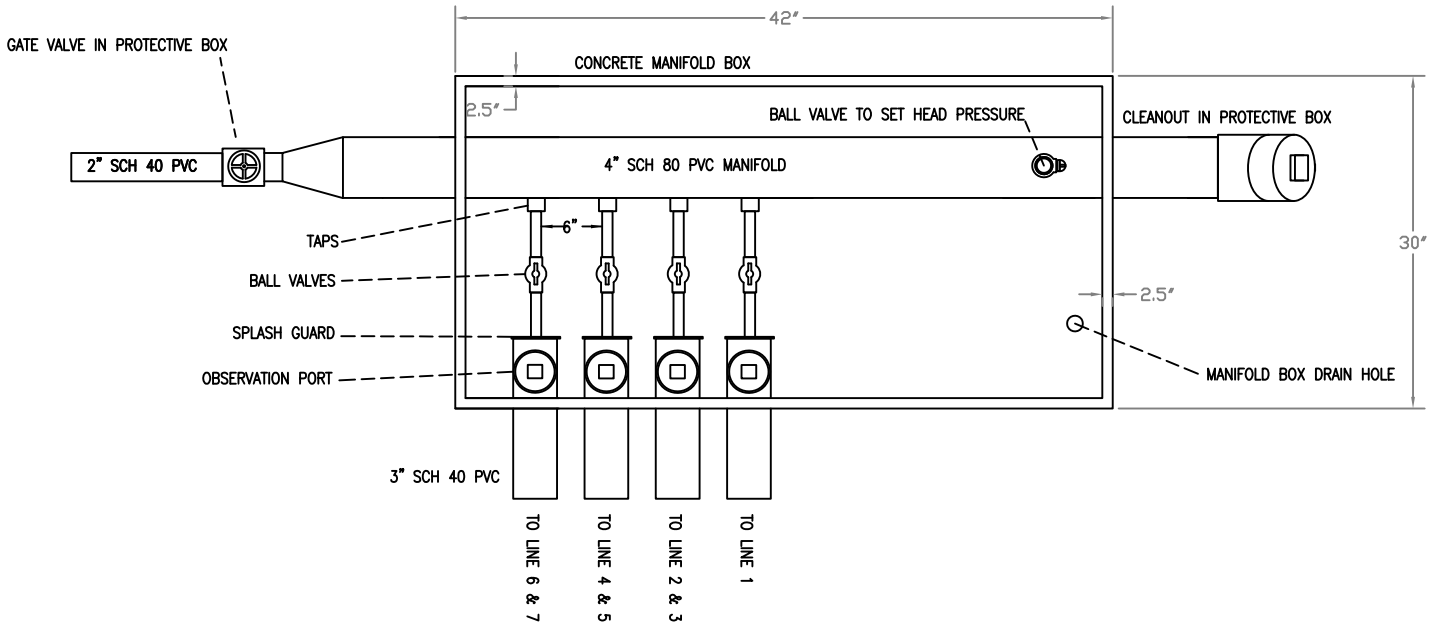

PRESSURE MANIFOLD DETAILS END VIEW

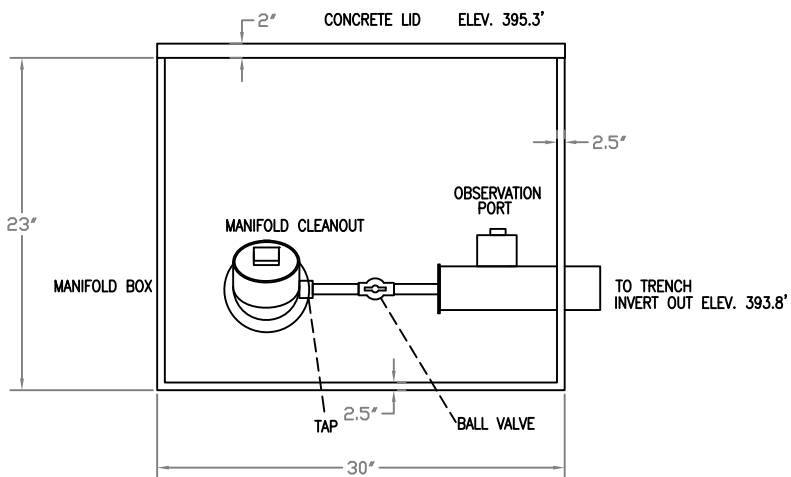

TAP SCHEDULE	
LINE #	TAP
1	$\frac{1}{2}$ " SCH 80
2 & 3	$\frac{1}{2}$ " SCH 40
4 & 5	$\frac{1}{2}$ " SCH 40
6 & 7	$\frac{1}{2}$ " SCH 40



Central Carolina Soil Consulting, PLLC
 1900 South Main Street, Suite 110
 Wake Forest, North Carolina 27587
 Phone (919)569-6704 Fax (919)569-6703

Manifold Details
 Cotton Farms Subdivision, Lot 58
 Harnett County, North Carolina

Job# : 4722
 Drawn By : JR
 Date : 05/06/2024

CAST-A-SEAL 402/402F

PIPE TO MANHOLE & TANK CONNECTOR

What It Is

The Cast-A-Seal 402/402F is a simple cast-in pipe-to-manhole connector that offers a watertight flexible connector that is cast into the structure when the concrete is poured.

The key lock is integrally cast-in during the production process providing a secure seal for storm water and sanitary collection systems.

How It Works

- The connector is folded into the casting position.
- It is placed on the reusable mandrel and then placed on the form.
- After curing, the mandrel is removed.
- The connector is then simply unfolded at the jobsite.
- Take-up clamps made from series 304 stainless steel with quick adjusting screws secure the connector to the pipe.



Why It's Better

- Durable and reusable mandrel forms.
- Integrally cast into the structure at time of casting.
- Contractor can backfill immediately after pipe insertion.
- The 4" connector is available in either open or closed end face.
- Contractor can save time and money by backfilling immediately.

Where To Use

- Manholes
- Wet wells
- Square pump and lift stations
- Stormwater structures
- On-site treatment structures
- Junction chambers
- Grease interceptors



Press-Seal believes all information is accurate as of its publication date. Information, specifications, and prices are all subject to change without notice. Press-Seal is not responsible for any inadvertent errors. Copyright 2022.

Phone: 800-348-7325
Fax: (260) 436-1908

PRESS-SEAL CORPORATION
Protecting Our Planet's Clean Water Supply
ISO 9001: Registered • Version 02.16.22.11.17

Email: sales@press-seal.com
Web: www.press-seal.com

CAST-A-SEAL 402/402F

SUBMITTAL SPECIFICATIONS

A flexible pipe-to-structure connector shall be employed in the connection of the sanitary sewer pipe to precast structures. The connector shall be Cast-A-Seal® 402/402F as manufactured by Press-Seal Corporation, Fort Wayne, Indiana, or approved equal. The connector shall be the sole element relied on to assure a flexible, watertight seal of the pipe to the precast structure. The connector shall consist of a rubber gasket and an external take-up clamp.

The rubber gasket element shall be constructed solely of synthetic or natural rubber, and shall meet or exceed the physical property requirements of ASTM C 923.

The external take-up clamp shall be constructed of Series 300 non-magnetic stainless steel and shall utilize no welds in its construction. The clamp shall be installed by torquing the adjusting screw using a torque-setting wrench available from the connector manufacturer.

Selection of the proper size connector for the structure and pipe requirement, and installation thereof, shall be in strict conformance with the recommendations of the connector manufacturer. Any dead end pipe stubs installed in connectors shall be restrained from movement per ASTM C 923.

The finished connection shall provide sealing to 13 psi (minimum) and shall accommodate deflection of the pipe to 7 degrees (minimum) without loss of seal.

Vacuum testing shall be conducted in strict conformance with ASTM C 1244 prior to backfill. Other testing shall be conducted in strict conformance with the requirements of the connector manufacturer.

Product Performance

Cast-A-Seal 402/402F meets and/or exceeds all requirements of ASTM C 923, including physical properties of materials and performance testing, including:

- 13 PSI minimum in straight alignment
- 10 PSI at minimum 7° angle
- 10 PSI minimum under shear load of 150 lbs/in. pipe diameter

Cast-A-Seal 402/402F meets and/or exceeds the requirements of the following Standards, Specifications, Codes, and Test Methods:

- IAPMO/ANSI Z1000 Standard for Prefabricated Septic Tanks
- IAPMO/ANSI Z1001 Standard for Prefabricated Gravity Grease Interceptors
- NPCA Best Practices Manual for Precast Concrete On-Site Wastewater Tanks
- NOWRA Model Code Framework
- ASTM C 1227 Standard Specification for Precast Concrete Septic Tanks
- ASTM C 1644 Standard Specification for Resilient Connectors Between Reinforced Concrete On-Site Wastewater Tanks and Pipes (CAS 402)
- ASTM C 1613 Standard Specification for Precast Concrete Grease Interceptor Tanks
- ASTM C 923 - Standard Specification for Resilient Connectors Between Reinforced Concrete Manhole Structures, Pipes, and Laterals
- ASTM C 1244 Standard Test Method for Concrete Sewer Manholes by the Negative Air Pressure (Vacuum) Test
- ASTM C 1478 - Standard Specification for Storm Drain Resilient Connectors Between Reinforced Concrete Storm Sewer Structures, Pipes, and Laterals

Press-Seal believes all information is accurate as of its publication date. Information, specifications, and prices are all subject to change without notice. Press-Seal is not responsible for any inadvertent errors. Copyright 2022.

Phone: 800-348-7325
Fax: (260) 436-1908

PRESS-SEAL CORPORATION
Protecting Our Planet's Clean Water Supply
ISO 9001: Registered • Version 02.16.22.11.17

Email: sales @press-seal.com
Web: www.press-seal.com



CAST-A-SEAL 402/402F

SELECTION GUIDE

PIPE SIZE	CAST-A-SEAL 402	PIPE O.D. RANGE	WALL THICKNESS*	APPLICATION
1.25" - 2" 31 - 51 mm	452.0250	1.5" - 2.75" 38 - 70 mm	2.5" - 6" 64 - 150 mm	STANDARD
4" 100 mm	452.0450	4.2" - 4.7" 107 - 119 mm	2.5" - 6" 64 - 150 mm	STANDARD
4" 100 mm	452.0402F1	4.2" - 4.7" 107 - 119 mm	2.5" - 4.0" 64 - 102 mm	Closed Face
6" 150 mm	452.0650	6.2" - 6.7" 157 - 170 mm	2.5" - 6" 64 - 150 mm	STANDARD
3" 75 mm	CAS ADAPTER	3.2" - 3.6" 81 - 91 mm	---	Use with 4" CAST-A-SEAL



Press-Seal believes all information is accurate as of its publication date. Information, specifications, and prices are all subject to change without notice. Press-Seal is not responsible for any inadvertent errors. Copyright 2022.

Phone: 800-348-7325
Fax: (260) 436-1908

PRESS-SEAL CORPORATION
Protecting Our Planet's Clean Water Supply
ISO 9001: Registered • Version 02.16.22.11.17

Email: sales@press-seal.com
Web: www.press-seal.com

INFILTRATOR WATER TECHNOLOGIES
EZSNAP SAFETY STAR
 (NOT ON SCALE)

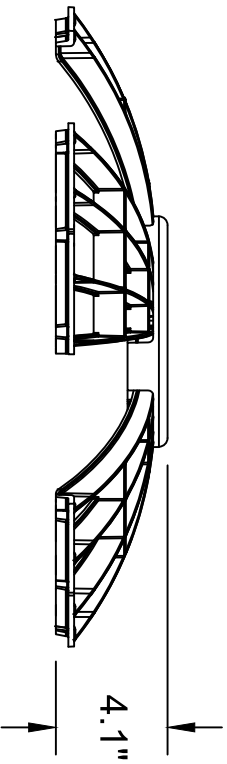
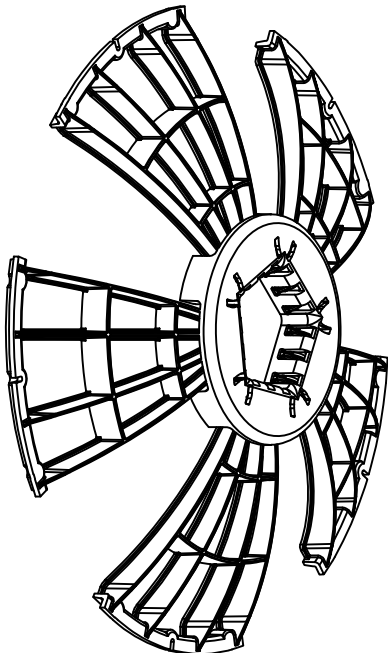
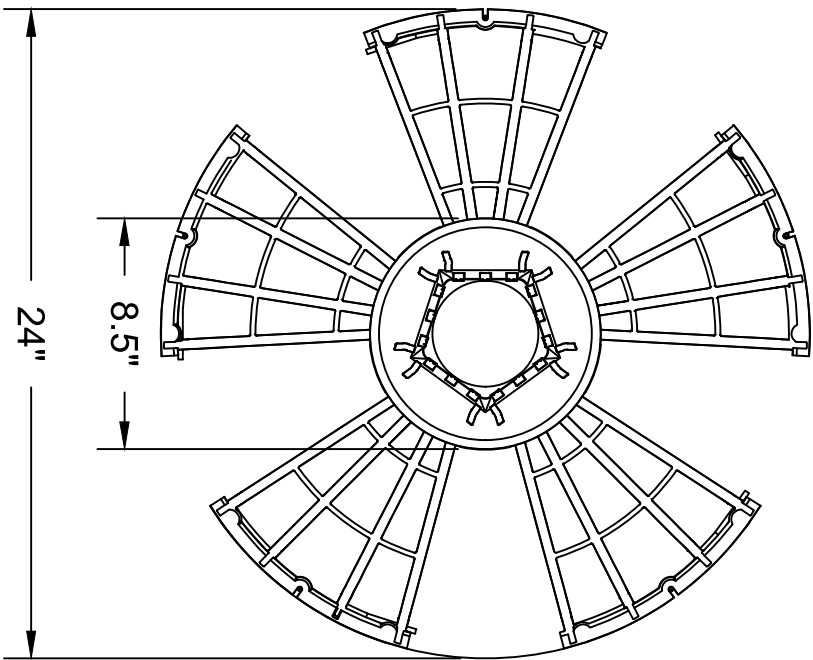

	
INFILTRATOR WATER TECHNOLOGIES 4 Business Park Rd. Old Saybrook, CT 06475 (800) 221-4436	
EZsnap SAFETY STAR SNAPSAFT-2400	
Drawn by: ADP	Date: 06/09/2023
Scale: NOT TO SCALE	Checked by:
Sheet: 1 of 1	

Safety Nets

24/7 protection from accidental and unauthorized entry

Sim/Tech Filter offers security nets for risers up to 36". The STF-N24 is designed to fit 18" to 24" risers, STF-N30 is designed to fit 24" to 30" risers while the STF-N36 is designed to fit 30" to 36". They attach with eye bolts so they will work for most risers. These nets provide protection from accidental or unauthorized entry into tanks. They stay in place at all times. This is a key feature as even the most secure cover is removed for system maintenance. If a service technician is distracted or needs to leave the access area for some reason the access is vulnerable to accidental entry. The net protects the access during these times as well. There is no impact on the service, pump hoses can be inserted through the web. Each net comes standard with 2 quick links (STF-QLINK) to allow for pump removals etc. More quick links are also available for instances where a larger opening is desired.

A safety device that works and won't cause a hassle!

Below is a 24" net installed in a Sim/Tech Riser. Shown in these pictures is a 4" diameter pipe inserted into an opening. These openings allow about a 5" diameter access. The standard net also comes with 2 quick links that can be temporarily disconnected to allow for pumps or other large items to pass through the net. Shown in the picture on the left is a standard residential size effluent pump sitting in the opening created by the quick link disconnection. If you require a larger opening more quick links can be added as depicted in the picture on the right.

STF-QLINK

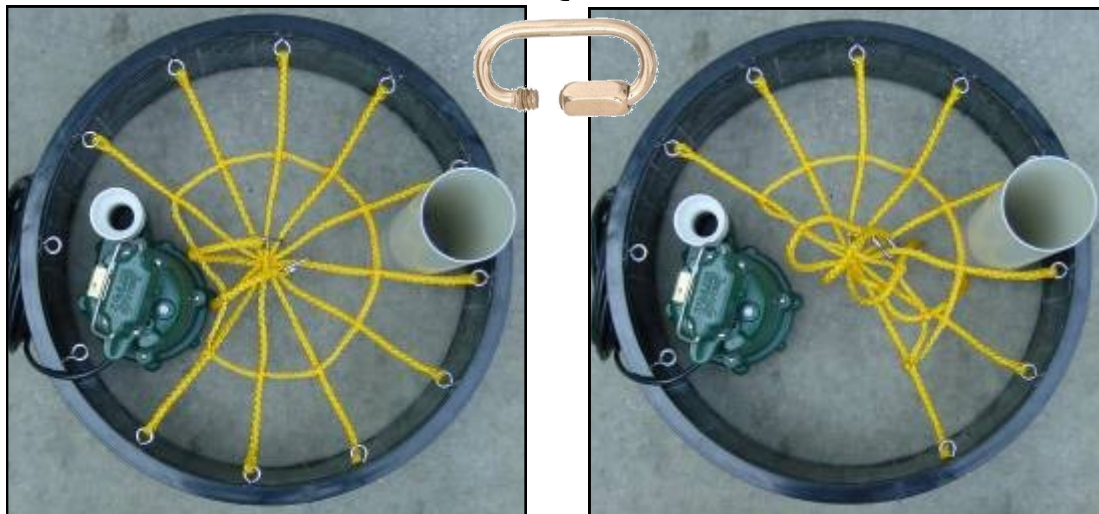

Solutions

For the protection and performance of wastewater systems by

SIM/TECH
FILTER

EZ-FLOW DETAILS

Example only: Installed trench bottom should match design.

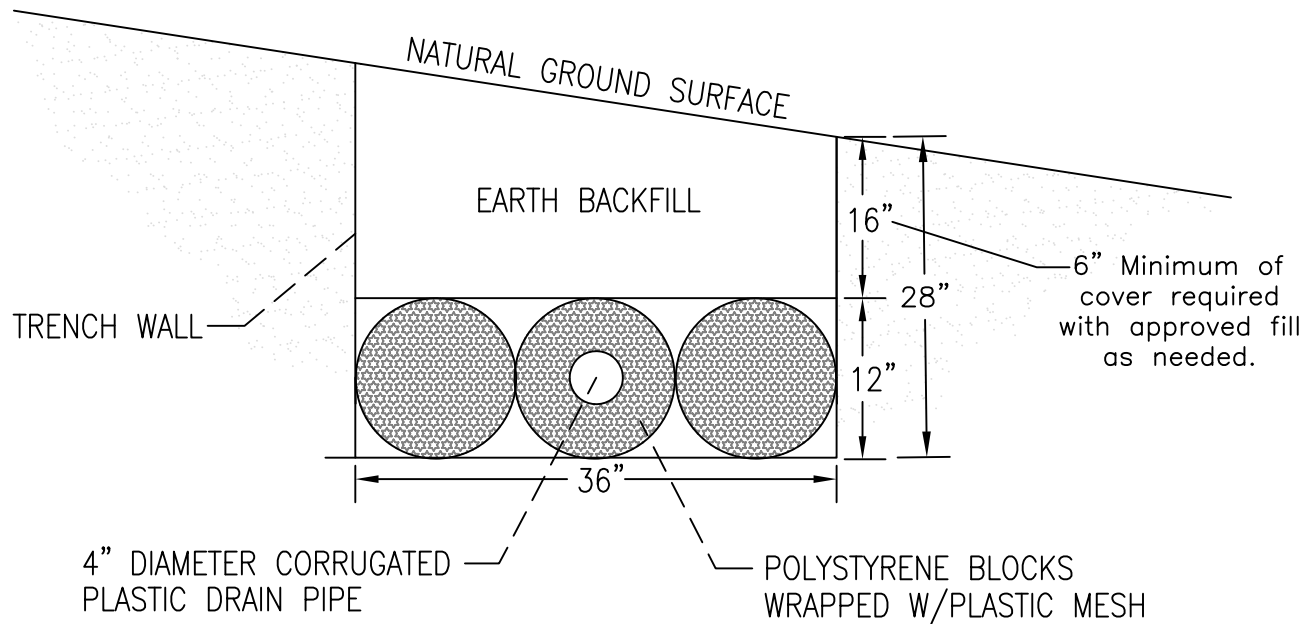

NOTE :

1. EZ-FLOW INSTALLATION SHALL MEET THE REQUIREMENTS INCLUDED IN ITS INNOVATIVE APPROVAL
2. TRENCH BOTTOM SHALL BE AT LEAST 12" FROM ANY RESTRICTIVE SOIL LAYER
3. END CAP SHALL BE PROVIDED AT END OF ALL CORRUGATED PLASTIC PIPE LINES AND TRENCH BOTTOMS SHALL BE LEVEL
4. THIS IS A GENERIC TRENCH PROFILE SEE IP and CA PERMIT FOR TRENCH DEPTH.



Central Carolina Soil Consulting, PLLC
1900 South Main Street, Suite 110
Wake Forest, North Carolina 27587
Phone (919)569-6704 Fax (919)569-6703

Trench Details
Cotton Farms Subdivision, Lot 58
Harnett County, North Carolina

Job# : 4722

Drawn By : JR

Date : 05/06/2024