



ROOF & FLOOR TRUSSES & BEAMS

Reilly Road Industrial Park
Fayetteville, N.C. 28309
Phone: (910) 864-8787
Fax: (910) 864-4444

Bearing reactions less than or equal to 3000# are deemed to comply with the prescriptive Code requirements. The contractor shall refer to the attached Tables (derived from the prescriptive Code requirements) to determine the minimum foundation size and number of wood studs required to support reactions greater than 3000# but not greater than 15000#. A registered design professional shall be retained to design the support system for any reaction that exceeds those specified in the attached Tables. A registered design professional shall be retained to design the support system for all reactions that exceed 15000#.

Signature Jonathan Landry
Jonathan Landry

LOAD CHART FOR JACK STUDS

(BASED ON TABLES R502.5(1) & (2))
NUMBER OF JACK STUDS REQUIRED @ EA END OF HEADER/GIRDER

END REACTION (UP TO)	REQ'D STUDS FOR (1) 1/2" HEADER	END REACTION (UP TO)	REQ'D STUDS FOR (1) 1/2" HEADER	END REACTION (UP TO)	REQ'D STUDS FOR (1) 1/2" HEADER
1700	1	2550	1	3400	1
3400	2	5100	2	6800	2
5100	3	7650	3	10200	3
6800	4	10200	4	13600	4
8500	5	12750	5	17000	5
10200	6	15300	6		
11900	7				
13600	8				
15300	9				

All Truss Reactions are Less than 3,000 lbs. Unless Noted Otherwise.
○ -- Denotes Reaction Greater than 3,000 lbs. Reaction / # of Studs

All Walls Shown Are Considered Load Bearing

Roof Area = 2513.27 sq.ft.
Ridge Line = 101 ft.
Hip Line = 0 ft.
Horiz. OH = 159.93 ft.
Raked OH = 194.82 ft.
Decking = 86 sheets

Dimension Notes
1. All exterior wall to wall dimensions are to face of sheathing unless noted otherwise
2. All interior wall dimensions are to face of stud unless noted otherwise
3. All exterior wall to truss dimensions are to face of stud unless noted otherwise

Hatch Legend

- Second Floor Walls
- Box Storage
- Drop Beam
- Flush Beam

Connector Information					Nail Information	
Sym	Product	Manuf	Qty	Supported Member	Header	Truss
■	HUS26	USP	14	NA	16d/3-1/2"	16d/3-1/2"

Products					
PlotID	Length	Product	Plies	Net Qty	Fab Type
BM1	4' 0"	2x10 SPF No.1	2	4	FF
BM2	9' 0"	1-3/4"x 14" LVL Kerto-S	2	2	FF
BM3	11' 0"	1-3/4"x 14" LVL Kerto-S	2	2	FF
GDH	21' 0"	1-3/4"x 16" LVL Kerto-S	2	2	FF
GDH2	13' 0"	1-3/4"x 11-7/8" LVL Kerto-S	2	2	FF

1 Truss Placement Plan
Scale: 1/4"=1'

▲ = Denotes Left End of Truss
(Reference Engineered Truss Drawing)

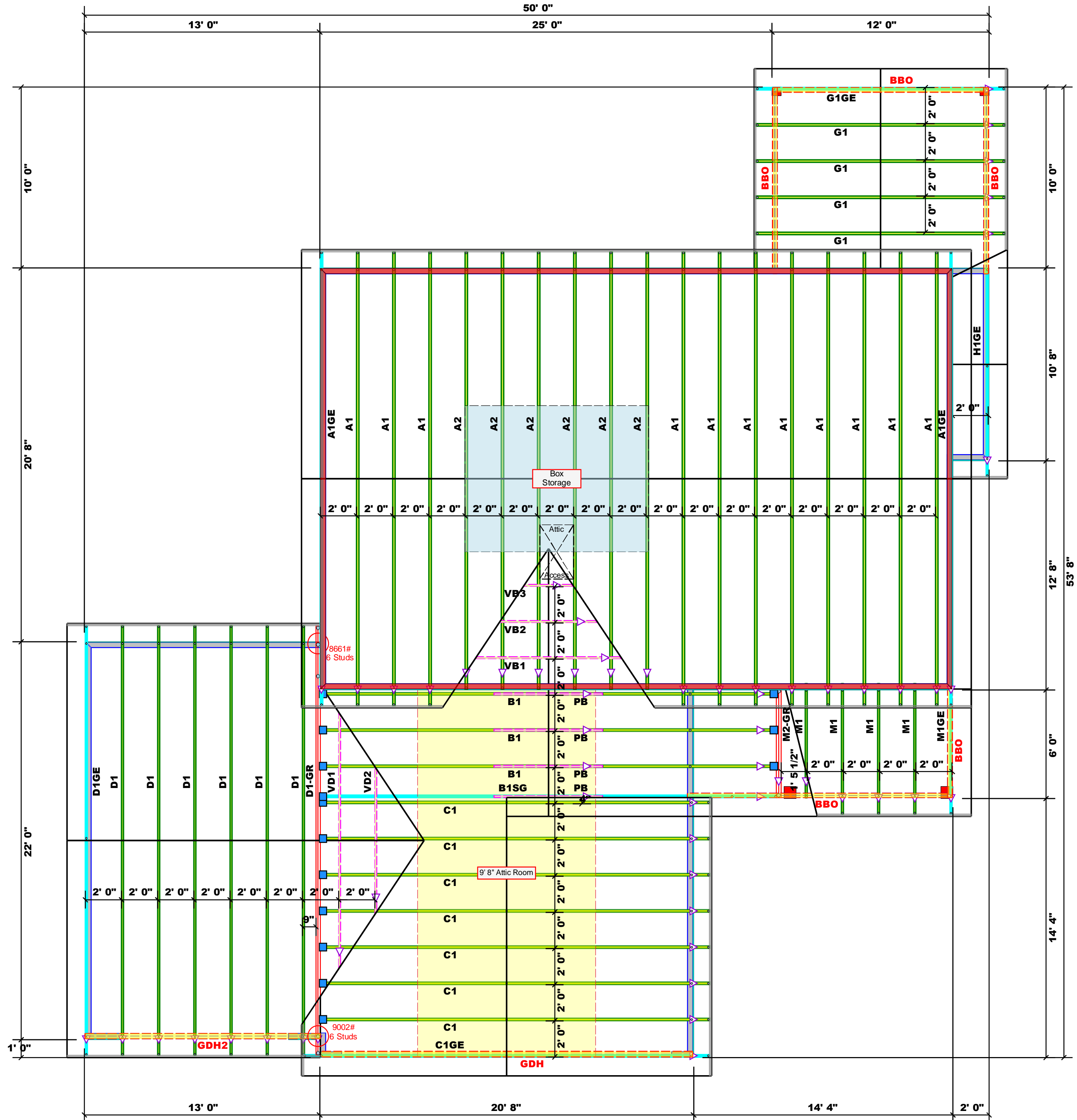

BUILDER	WEAVER DEVELOPMENT	CITY / CO.	SANFORD / HARNETT
JOB NAME	Lot 2 West Pointe III	ADDRESS	53 Hillwood Court
PLAN	Nicholson / 3GRF, CP	MODEL	Roof
SEAL DATE	N/A	DATE REV.	09/21/23
QUOTE #		DRAWN BY	Jonathan Landry
JOB #	J0623-2991	SALES REP.	Lenny Norris

THIS IS A TRUSS PLACEMENT DIAGRAM ONLY. These trusses are designed as individual building components to be incorporated into the building design at the specification of the building designer. See individual design sheets for each truss design identified on the placement drawing. The building designer is responsible for temporary and permanent bracing of the roof and floor system and for the overall structure. The design of the truss support structure including headers, beams, walls, and columns is the responsibility of the building designer. For general guidance regarding bracing, consult BCSI-B1 and BCSI-B3 provided with the truss delivery package or online @ sbciindustry.com

Bearing reactions less than or equal to 3000# are deemed to comply with the prescriptive Code requirements. The contractor shall refer to the attached Tables (derived from the prescriptive Code requirements) to determine the minimum foundation size and number of wood studs required to support reactions greater than 3000# but not greater than 15000#. A registered design professional shall be retained to design the support system for any reaction that exceeds those specified in the attached Tables. A registered design professional shall be retained to design the support system for all reactions that exceed 15000#.

Signature Jonathan Landry
Jonathan Landry

LOAD CHART FOR JACK STUDS

(BASED ON TABLES R502.5(1) & (b))
NUMBER OF JACK STUDS REQUIRED @ EA END OF HEADER/GIRDER

END REACTION (UP TO)	REQ'D STUDS FOR (1) 1/4" HEADER	END REACTION (UP TO)	REQ'D STUDS FOR (1) 1/4" HEADER	END REACTION (UP TO)	REQ'D STUDS FOR (1) 1/4" HEADER
1700	1	2550	1	3400	1
3400	2	5100	2	6800	2
5100	3	7650	3	10200	3
6800	4	10200	4	13600	4
8500	5	12750	5	17000	5
10200	6	15300	6		
11900	7				
13600	8				
15300	9				

All Truss Reactions are Less than 3,000 lbs. Unless Noted Otherwise.
○ -- Denotes Reaction Greater than 3,000 lbs. Reaction / # of Studs

All Walls Shown Are Considered Load Bearing

Roof Area = 2513.27 sq.ft.
Ridge Line = 101 ft.
Hip Line = 0 ft.
Horiz. OH = 159.93 ft.
Raked OH = 194.82 ft.
Decking = 86 sheets

- Dimension Notes**
- All exterior wall to wall dimensions are to face of sheathing unless noted otherwise
 - All interior wall dimensions are to face of stud unless noted otherwise
 - All exterior wall to truss dimensions are to face of stud unless noted otherwise

Hatch Legend

- Second Floor Walls
- Box Storage
- Drop Beam
- Flush Beam

Connector Information					Nail Information	
Sym	Product	Manuf	Qty	Supported Member	Header	Truss
■	HUS26	USP	14	NA	16d/3-1/2"	16d/3-1/2"

Products

PlotID	Length	Product	Plies	Net Qty	Fab Type
BM1	4' 0"	2x10 SPF No.1	2	4	FF
BM2	9' 0"	1-3/4"x 14" LVL Kerto-S	2	2	FF
BM3	11' 0"	1-3/4"x 14" LVL Kerto-S	2	2	FF
GDH	21' 0"	1-3/4"x 16" LVL Kerto-S	2	2	FF
GDH2	13' 0"	1-3/4"x 11-7/8" LVL Kerto-S	2	2	FF

1 Truss Placement Plan
Scale: 1/4"=1'

▲ = Denotes Left End of Truss
(Reference Engineered Truss Drawing)

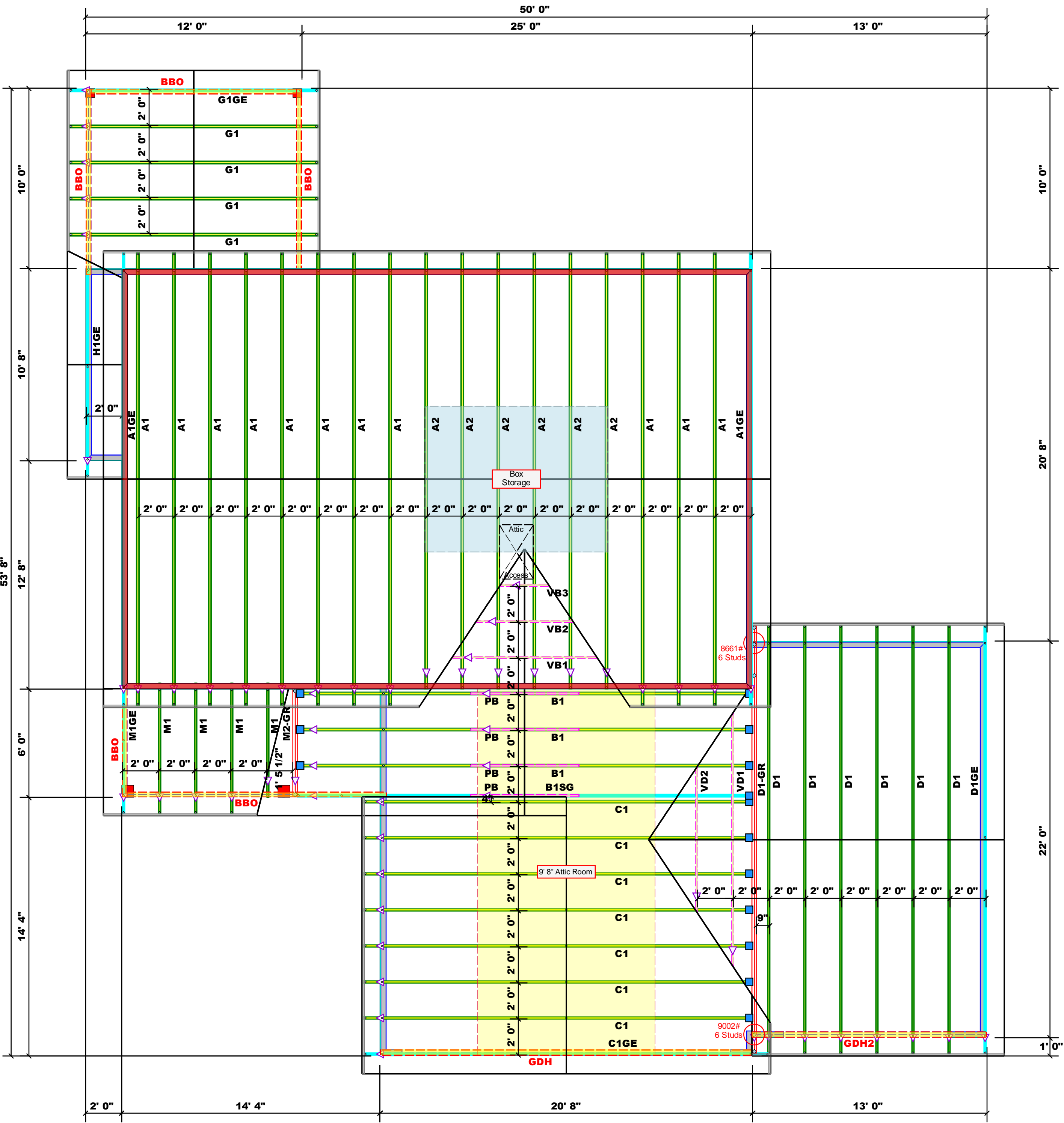

BUILDER	WEAVER DEVELOPMENT	CITY / CO.	SANFORD / HARNETT
JOB NAME	Lot 2 West Pointe III	ADDRESS	53 Hillwood Court
PLAN	Nicholson / 3GRF, CP	MODEL	Roof
SEAL DATE	N/A	DATE REV.	09/21/23
QUOTE #		DRAWN BY	Jonathan Landry
JOB #	J0623-2991	SALES REP.	Lenny Norris

THIS IS A TRUSS PLACEMENT DIAGRAM ONLY. These trusses are designed as individual building components to be incorporated into the building design at the specification of the building designer. See individual design sheets for each truss design identified on the placement drawing. The building designer is responsible for temporary and permanent bracing of the roof and floor system and for the overall structure. The design of the truss support structure including headers, beams, walls, and columns is the responsibility of the building designer. For general guidance regarding bracing, consult BCSI-B1 and BCSI-B3 provided with the truss delivery package or online @ sbcindustry.com

RE: J0623-2991
 Lot 2 West Pointe III

Trenco
 818 Soundside Rd
 Edenton, NC 27932

Site Information:

Customer: Weaver Development Project Name: J0623-2991
 Lot/Block: 2 Model: Nicholson
 Address: 53 Hillwood Court Subdivision: West Pointe III
 City: Sanford State: NC

General Truss Engineering Criteria & Design Loads (Individual Truss Design Drawings Show Special Loading Conditions):

Design Code: IRC2015/TPI2014 Design Program: MiTek 20/20 8.4
 Wind Code: ASCE 7-10 Wind Speed: 150 mph
 Roof Load: 40.0 psf Floor Load: N/A psf

This package includes 22 individual, dated Truss Design Drawings and 0 Additional Drawings.

No.	Seal#	Truss Name	Date	No.	Seal#	Truss Name	Date
1	I57942376	A1	4/25/2023	21	I57942396	VD1	4/25/2023
2	I57942377	A1GE	4/25/2023	22	I57942397	VD2	4/25/2023
3	I57942378	A2	4/25/2023				
4	I57942379	B1	4/25/2023				
5	I57942380	B1SG	4/25/2023				
6	I57942381	C1	4/25/2023				
7	I57942382	C1GE	4/25/2023				
8	I57942383	D1	4/25/2023				
9	I57942384	D1-GR	4/25/2023				
10	I57942385	D1GE	4/25/2023				
11	I57942386	G1	4/25/2023				
12	I57942387	G1GE	4/25/2023				
13	I57942388	H1GE	4/25/2023				
14	I57942389	M1	4/25/2023				
15	I57942390	M1GE	4/25/2023				
16	I57942391	M2-GR	4/25/2023				
17	I57942392	PB	4/25/2023				
18	I57942393	VB1	4/25/2023				
19	I57942394	VB2	4/25/2023				
20	I57942395	VB3	4/25/2023				

The truss drawing(s) referenced above have been prepared by Truss Engineering Co. under my direct supervision based on the parameters provided by Comtech, Inc - Fayetteville.

Truss Design Engineer's Name: Gilbert, Eric

My license renewal date for the state of North Carolina is December 31, 2023.

North Carolina COA: C-0844

IMPORTANT NOTE: The seal on these truss component designs is a certification that the engineer named is licensed in the jurisdiction(s) identified and that the designs comply with ANSI/TPI 1. These designs are based upon parameters shown (e.g., loads, supports, dimensions, shapes and design codes), which were given to TRENCO. Any project specific information included is for TRENCO customers file reference purpose only, and was not taken into account in the preparation of these designs. TRENCO has not independently verified the applicability of the design parameters or the designs for any particular building. Before use, the building designer should verify applicability of design parameters and properly incorporate these designs into the overall building design per ANSI/TPI 1, Chapter 2.

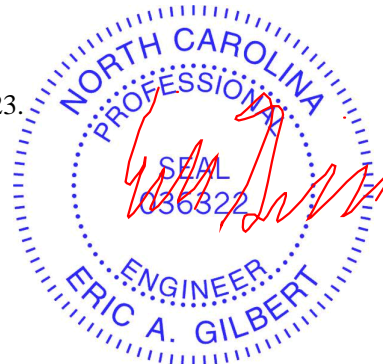

April 25, 2023

Job	Truss	Truss Type	Qty	Ply	Lot 2 West Pointe III	157942376
J0623-2991	A1	COMMON	11	1		

Comtech, Inc, Fayetteville, NC - 28314,

8.430 s Jan 6 2022 MiTek Industries, Inc. Mon Apr 24 12:27:31 2023 Page 1

ID:uB1kUybQLa2UVI5EAk1M8Myf?Wk-9w6mYHSXn1LC0oAjfWnaG9NqeeNjgFdJce5?0VzNVlw

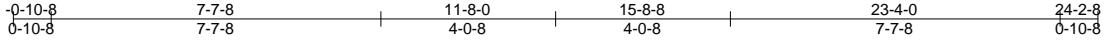

4x6 ==

Scale = 1:53.3

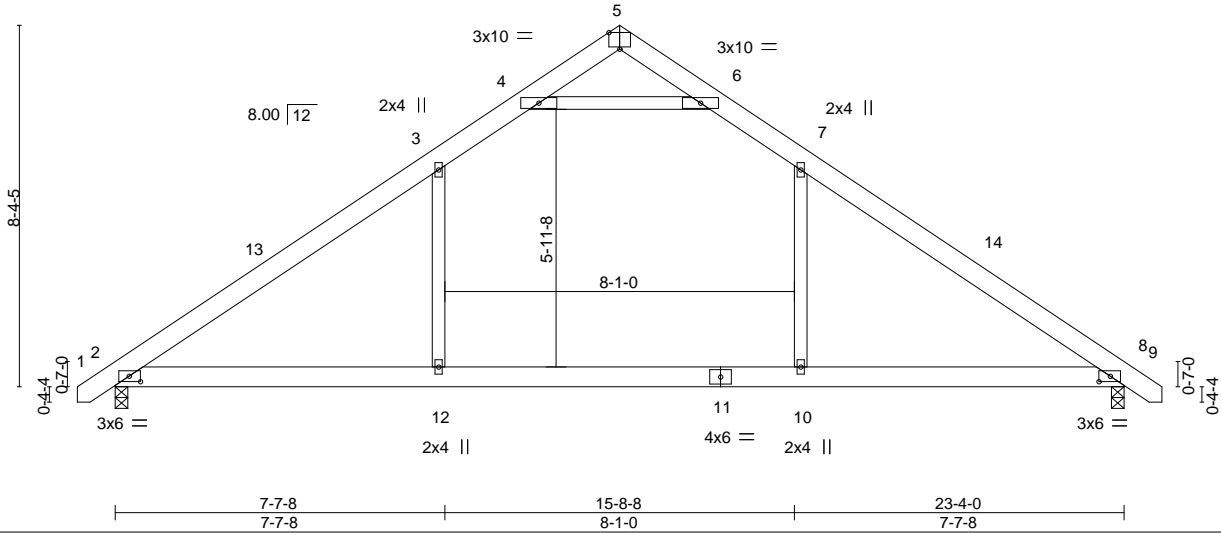

Plate Offsets (X,Y)-- [2:0-3-2,0-1-8], [5:0-3-0,Edge], [8:0-3-3,0-1-8]

LOADING (psf)	SPACING-	CSI.	DEFL.	in	(loc)	l/defl	L/d	PLATES	GRIP
TCLL 20.0	Plate Grip DOL 1.15	TC 0.49	Vert(LL) -0.16	2-12	>999	360		MT20	244/190
TCDL 10.0	Lumber DOL 1.15	BC 0.31	Vert(CT) -0.23	2-12	>999	240			
BCLL 0.0 *	Rep Stress Incr YES	WB 0.51	Horz(CT) 0.02	8	n/a	n/a			
BCDL 10.0	Code IRC2015/TPI2014	Matrix-S	Wind(LL) 0.18	2-12	>999	240			
								Weight: 146 lb	FT = 20%

LUMBER-
 TOP CHORD 2x6 SP No.1
 BOT CHORD 2x6 SP No.1
 WEBS 2x4 SP No.2

BRACING-
 TOP CHORD Structural wood sheathing directly applied or 5-10-5 oc purlins.
 BOT CHORD Rigid ceiling directly applied or 10-0-0 oc bracing.

REACTIONS. (size) 2=0-3-8, 8=0-3-8
 Max Horz 2=264(LC 11)
 Max Uplift 2=-176(LC 12), 8=-176(LC 13)
 Max Grav 2=974(LC 1), 8=974(LC 1)

FORCES. (lb) - Max. Comp./Max. Ten. - All forces 250 (lb) or less except when shown.
 TOP CHORD 2-3=-1284/418, 3-4=-1089/479, 4-5=-174/468, 5-6=-174/468, 6-7=-1089/479,
 7-8=-1284/418
 BOT CHORD 2-12=-154/906, 10-12=-154/906, 8-10=-154/906
 WEBS 7-10=0/349, 3-12=0/349, 4-6=-1815/761

- NOTES-**
- Unbalanced roof live loads have been considered for this design.
 - Wind: ASCE 7-10; Vult=150mph Vasd=119mph; TCDL=6.0psf; BCDL=6.0psf; h=15ft; Cat. II; Exp C; Enclosed; MWFRS (envelope) and C-C Exterior(2) -0-8-12 to 3-8-1, Interior(1) 3-8-1 to 11-8-0, Exterior(2) 11-8-0 to 15-10-4, Interior(1) 15-10-4 to 24-0-12 zone; C-C for members and forces & MWFRS for reactions shown; Lumber DOL=1.60 plate grip DOL=1.60
 - This truss has been designed for a 10.0 psf bottom chord live load nonconcurrent with any other live loads.
 - * This truss has been designed for a live load of 20.0psf on the bottom chord in all areas with a clearance greater than 6-0-0 between the bottom chord and any other members.
 - Provide mechanical connection (by others) of truss to bearing plate capable of withstanding 176 lb uplift at joint 2 and 176 lb uplift at joint 8.



April 25, 2023

WARNING - Verify design parameters and READ NOTES ON THIS AND INCLUDED MITEK REFERENCE PAGE MII-7473 rev. 1/2/2023 BEFORE USE.

Design valid for use only with MiTek® connectors. This design is based only upon parameters shown, and is for an individual building component, not a truss system. Before use, the building designer must verify the applicability of design parameters and properly incorporate this design into the overall building design. Bracing indicated is to prevent buckling of individual truss web and/or chord members only. Additional temporary and permanent bracing is always required for stability and to prevent collapse with possible personal injury and property damage. For general guidance regarding the fabrication, storage, delivery, erection and bracing of trusses and truss systems, see **ANSI/TPH Quality Criteria and DSB-22** available from Truss Plate Institute (www.tpinst.org) and **BCSI Building Component Safety Information** available from the Structural Building Component Association (www.sbcacomponents.com)



818 Soundside Road
 Edenton, NC 27932

Job	Truss	Truss Type	Qty	Ply	Lot 2 West Pointe III	157942377
J0623-2991	A1GE	GABLE	2	1	Job Reference (optional)	

Comtech, Inc., Fayetteville, NC - 28314,

8.430 s Jan 6 2022 MiTek Industries, Inc. Mon Apr 24 12:27:34 2023 Page 1
 ID:uB1kUybQLa2UVI5EAK1M8Myf?Wk-aVouAJUP4yintGvIKelHuo?SssTwhVIIcKfcpzNVlt

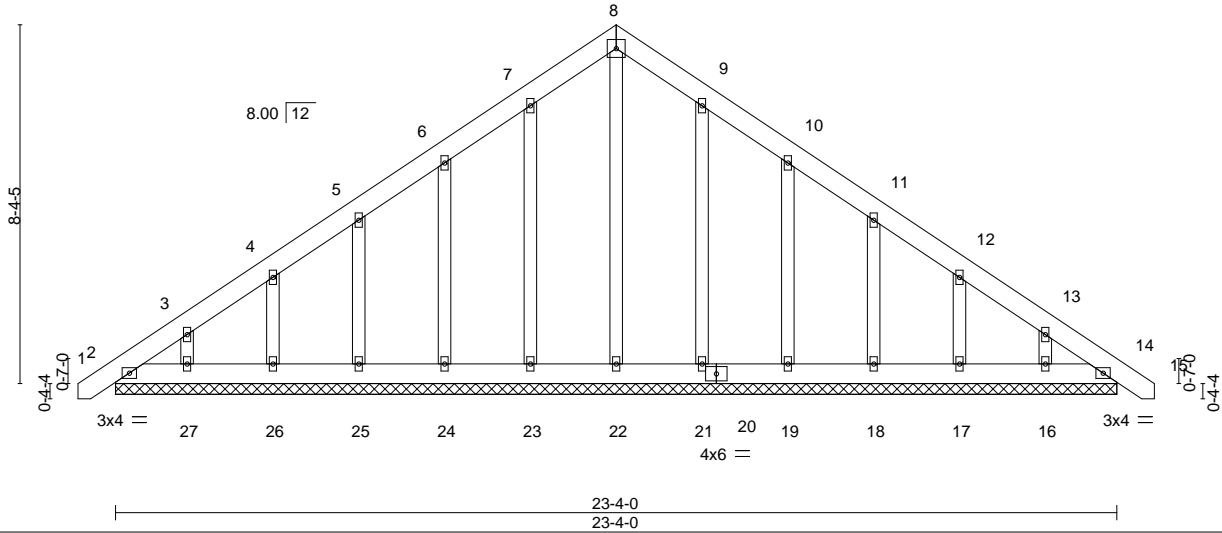
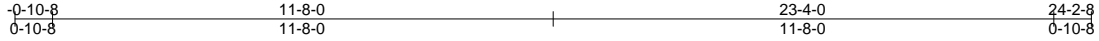

LOADING (psf)	SPACING-	2-0-0	CSI.	DEFL.	in	(loc)	l/defl	L/d	PLATES	GRIP
TCLL 20.0	Plate Grip DOL	1.15	TC 0.05	Vert(LL)	-0.00	14	n/r	120	MT20	244/190
TCDL 10.0	Lumber DOL	1.15	BC 0.02	Vert(CT)	0.00	14	n/r	120		
BCLL 0.0 *	Rep Stress Incr	YES	WB 0.18	Horz(CT)	0.01	14	n/a	n/a		
BCDL 10.0	Code IRC2015/TPI2014		Matrix-S						Weight: 188 lb	FT = 20%

LUMBER-

TOP CHORD 2x6 SP No.1
 BOT CHORD 2x6 SP No.1
 OTHERS 2x4 SP No.2

BRACING-

TOP CHORD Structural wood sheathing directly applied or 6-0-0 oc purlins.
 BOT CHORD Rigid ceiling directly applied or 10-0-0 oc bracing.

REACTIONS.

All bearings 23-4-0.
 (lb) - Max Horz 2=330(LC 11)
 Max Uplift All uplift 100 lb or less at joint(s) 2, 14, 21 except 23=107(LC 12), 24=144(LC 12), 25=131(LC 12), 26=134(LC 12), 27=135(LC 12), 19=147(LC 13), 18=131(LC 13), 17=134(LC 13), 16=132(LC 13)
 Max Grav All reactions 250 lb or less at joint(s) 2, 14, 23, 24, 25, 26, 27, 21, 19, 18, 17, 16 except 22=265(LC 22)

FORCES. (lb) - Max. Comp./Max. Ten. - All forces 250 (lb) or less except when shown.

TOP CHORD 2-3=-321/243, 7-8=-249/280, 8-9=-249/280
 BOT CHORD 2-27=-161/255, 26-27=-161/255, 25-26=-161/255, 24-25=-161/255, 23-24=-161/255, 22-23=-161/255, 21-22=-161/255, 19-21=-161/255, 18-19=-161/255, 17-18=-161/255, 16-17=-161/255, 14-16=-161/255

NOTES-

- Unbalanced roof live loads have been considered for this design.
- Wind: ASCE 7-10; Vult=150mph Vasd=119mph; TCDL=6.0psf; BCDL=6.0psf; h=15ft; Cat. II; Exp C; Enclosed; MWFRS (envelope) gable end zone and C-C Exterior(2) zone; C-C for members and forces & MWFRS for reactions shown; Lumber DOL=1.60 plate grip DOL=1.60
- Truss designed for wind loads in the plane of the truss only. For studs exposed to wind (normal to the face), see Standard Industry Gable End Details as applicable, or consult qualified building designer as per ANSI/TPI 1.
- All plates are 2x4 MT20 unless otherwise indicated.
- Gable requires continuous bottom chord bearing.
- Gable studs spaced at 2-0-0 oc.
- This truss has been designed for a 10.0 psf bottom chord live load nonconcurrent with any other live loads.
- * This truss has been designed for a live load of 20.0psf on the bottom chord in all areas with a clearance greater than 6-0-0 between the bottom chord and any other members, with BCDL = 10.0psf.
- Provide mechanical connection (by others) of truss to bearing plate capable of withstanding 100 lb uplift at joint(s) 2, 14, 21 except (jt=lb) 23=107, 24=144, 25=131, 26=134, 27=135, 19=147, 18=131, 17=134, 16=132.



April 25, 2023

WARNING - Verify design parameters and READ NOTES ON THIS AND INCLUDED MITEK REFERENCE PAGE MII-7473 rev. 1/2/2023 BEFORE USE.

Design valid for use only with MiTek® connectors. This design is based only upon parameters shown, and is for an individual building component, not a truss system. Before use, the building designer must verify the applicability of design parameters and properly incorporate this design into the overall building design. Bracing indicated is to prevent buckling of individual truss web and/or chord members only. Additional temporary and permanent bracing is always required for stability and to prevent collapse with possible personal injury and property damage. For general guidance regarding the fabrication, storage, delivery, erection and bracing of trusses and truss systems, see **ANSI/TPI1 Quality Criteria and DSB-22** available from Truss Plate Institute (www.tpinst.org) and **BCSI Building Component Safety Information** available from the Structural Building Component Association (www.sbcacomponents.com)



818 Soundside Road
 Edenton, NC 27932

Job	Truss	Truss Type	Qty	Ply	Lot 2 West Pointe III	157942378
J0623-2991	A2	COMMON	6	1	Job Reference (optional)	

Comtech, Inc, Fayetteville, NC - 28314,

8.430 s Jan 6 2022 MiTek Industries, Inc. Mon Apr 24 12:27:36 2023 Page 1

ID:uB1kUybQLa2UVI5EAk1M8Myf?Wk-Wuvfb_WgcazV7Z3hS3NizD5hDf3JLVp2lwpmhizNVlr

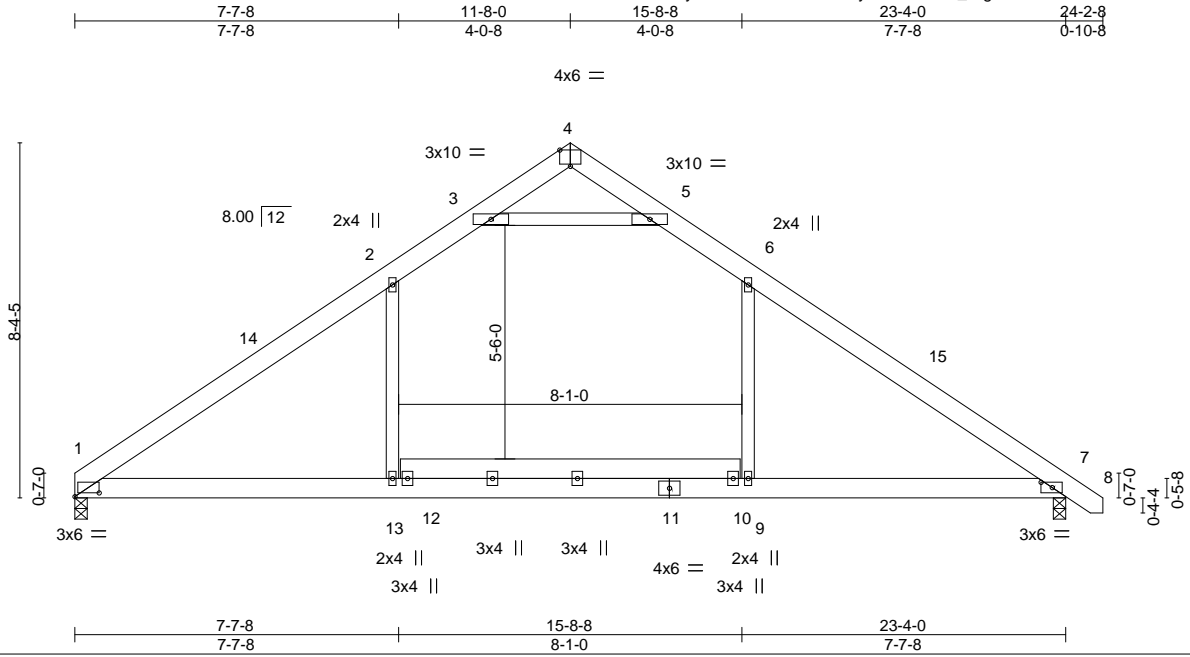

Scale = 1:54.3

Plate Offsets (X,Y)-- [1:0-6-14,0-1-1], [4:0-3-0,Edge], [7:0-3-3,0-1-8]

LOADING (psf)	SPACING-	CSI.	DEFL.	in (loc)	l/defl	L/d	PLATES	GRIP
TCLL 20.0	Plate Grip DOL 1.15	TC 0.50	Vert(LL) -0.15	1-13	>999	360	MT20	244/190
TCDL 10.0	Lumber DOL 1.15	BC 0.35	Vert(CT) -0.22	1-13	>999	240		
BCLL 0.0 *	Rep Stress Incr YES	WB 0.51	Horz(CT) 0.02	7	n/a	n/a		
BCDL 10.0	Code IRC2015/TPI2014	Matrix-S	Wind(LL) 0.17	1-13	>999	240		
							Weight: 162 lb	FT = 20%

LUMBER-
 TOP CHORD 2x6 SP No.1
 BOT CHORD 2x6 SP No.1
 WEBS 2x4 SP No.2

BRACING-
 TOP CHORD Structural wood sheathing directly applied or 5-8-10 oc purlins.
 BOT CHORD Rigid ceiling directly applied or 10-0-0 oc bracing.

REACTIONS. (size) 1=0-3-8, 7=0-3-8
 Max Horz 1=-259(LC 8)
 Max Uplift 1=-156(LC 12), 7=-176(LC 13)
 Max Grav 1=921(LC 1), 7=975(LC 1)

FORCES. (lb) - Max. Comp./Max. Ten. - All forces 250 (lb) or less except when shown.
 TOP CHORD 1-2=-1279/420, 2-3=-1093/489, 3-4=-178/473, 4-5=-188/477, 5-6=-1089/480,
 6-7=-1286/422
 BOT CHORD 1-13=-164/908, 9-13=-169/909, 7-9=-164/908
 WEBS 6-9=-5/349, 2-13=-4/344, 3-5=-1827/788

- NOTES-**
- Unbalanced roof live loads have been considered for this design.
 - Wind: ASCE 7-10; Vult=150mph Vasd=119mph; TCCL=6.0psf; BCDL=6.0psf; h=15ft; Cat. II; Exp C; Enclosed; MWFRS (envelope) and C-C Exterior(2) 0-1-12 to 4-6-9, Interior(1) 4-6-9 to 11-8-0, Exterior(2) 11-8-0 to 15-10-4, Interior(1) 15-10-4 to 24-0-12 zone; C-C for members and forces & MWFRS for reactions shown; Lumber DOL=1.60 plate grip DOL=1.60
 - This truss has been designed for a 10.0 psf bottom chord live load nonconcurrent with any other live loads.
 - * This truss has been designed for a live load of 20.0psf on the bottom chord in all areas with a clearance greater than 6-0-0 between the bottom chord and any other members.
 - Provide mechanical connection (by others) of truss to bearing plate capable of withstanding 100 lb uplift at joint(s) except (jt=lb) 1=156, 7=176.

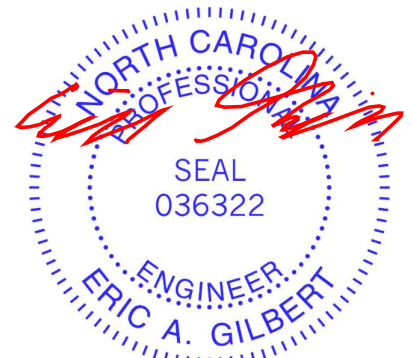

April 25, 2023

WARNING - Verify design parameters and READ NOTES ON THIS AND INCLUDED MITEK REFERENCE PAGE MII-7473 rev. 1/2/2023 BEFORE USE.
 Design valid for use only with MiTek® connectors. This design is based only upon parameters shown, and is for an individual building component, not a truss system. Before use, the building designer must verify the applicability of design parameters and properly incorporate this design into the overall building design. Bracing indicated is to prevent buckling of individual truss web and/or chord members only. Additional temporary and permanent bracing is always required for stability and to prevent collapse with possible personal injury and property damage. For general guidance regarding the fabrication, storage, delivery, erection and bracing of trusses and truss systems, see **ANSI/TPH Quality Criteria and DSB-22** available from Truss Plate Institute (www.tpinst.org) and **BCSI Building Component Safety Information** available from the Structural Building Component Association (www.sbcacomponents.com)



818 Soundside Road
 Edenton, NC 27932

Job	Truss	Truss Type	Qty	Ply	Lot 2 West Pointe III	I57942380
J0623-2991	B1SG	GABLE	1	1	Job Reference (optional)	

Comtech, Inc, Fayetteville, NC - 28314,

8.430 s Jan 6 2022 MiTek Industries, Inc. Mon Apr 24 12:27:42 2023 Page 2
 ID:uB1kUybQLa2UVI5EAk1M8Myf?Wk-L2Gws2aQBQkerUWqoKUADULx45PI9sx8rG4uMzNVII

NOTES-

- 12) Provide mechanical connection (by others) of truss to bearing plate capable of withstanding 100 lb uplift at joint(s) 23, 21.
- 13) Graphical purlin representation does not depict the size or the orientation of the purlin along the top and/or bottom chord.
- 14) Attic room checked for L/360 deflection.

WARNING - Verify design parameters and READ NOTES ON THIS AND INCLUDED MITEK REFERENCE PAGE MII-7473 rev. 1/2/2023 BEFORE USE.

Design valid for use only with MiTek® connectors. This design is based only upon parameters shown, and is for an individual building component, not a truss system. Before use, the building designer must verify the applicability of design parameters and properly incorporate this design into the overall building design. Bracing indicated is to prevent buckling of individual truss web and/or chord members only. Additional temporary and permanent bracing is always required for stability and to prevent collapse with possible personal injury and property damage. For general guidance regarding the fabrication, storage, delivery, erection and bracing of trusses and truss systems, see **ANSI/TP1 Quality Criteria and DSB-22** available from Truss Plate Institute (www.tpinst.org) and **BCSI Building Component Safety Information** available from the Structural Building Component Association (www.sbcacomponents.com)



818 Soundside Road
 Edenton, NC 27932

Job J0623-2991	Truss C1	Truss Type ATTIC	Qty 7	Ply 1	Lot 2 West Pointe III Job Reference (optional)	157942381
-------------------	-------------	---------------------	----------	----------	---	-----------

Comtech, Inc., Fayetteville, NC - 28314,

8.430 s Jan 6 2022 MiTek Industries, Inc. Mon Apr 24 12:27:44 2023 Page 1

ID:uB1kUybQLa2UVI5EAK1M8Myf?Wk-HQOgHkchj1_M4ogDwlWlvQ5aumFDBiDb9IBzEzNVJj
 0-11-0 5-2-12 8-2-1 10-3-8 12-4-15 15-4-4 20-7-0
 0-11-0 5-2-12 2-11-5 2-1-7 2-1-7 2-11-5 5-2-12

6x8 =

Scale = 1:86.5

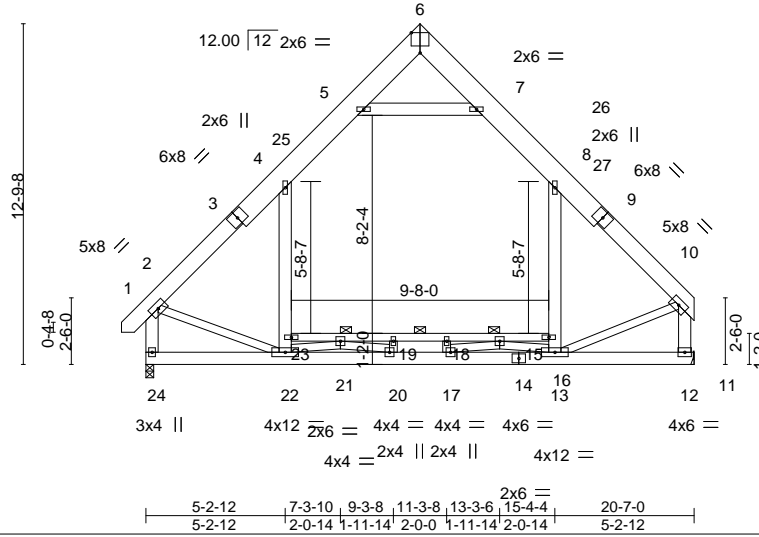

Plate Offsets (X,Y)--	[6:0-4-0,Edge]
-----------------------	----------------

LOADING (psf)	SPACING-	CSI.	DEFL.	4x4 =	in (loc)	l/defl	L/d	PLATES	GRIP
TCLL 20.0	Plate Grip DOL 1.15	TC 0.29	Vert(LL) -0.07	18-19	>999	360		MT20	244/190
TCDL 10.0	Lumber DOL 1.15	BC 0.47	Vert(CT) -0.13	18-19	>999	240			
BCLL 0.0 *	Rep Stress Incr YES	WB 0.20	Horz(CT) 0.02	12	n/a	n/a			
BCDL 10.0	Code IRC2015/TPI2014	Matrix-S	Wind(LL) 0.06	22	>999	240			
								Weight: 251 lb	FT = 20%

LUMBER-	BRACING-
TOP CHORD 2x10 SP No.1 *Except* 1-3,9-10: 2x8 SP No.1	TOP CHORD Structural wood sheathing directly applied or 6'-0-0 oc purlins, except end verticals.
BOT CHORD 2x6 SP No.1 *Except* 15-23: 2x4 SP No.1	BOT CHORD Rigid ceiling directly applied or 10'-0-0 oc bracing. Except: 4'-10-0 oc bracing: 16-21 6'-0-0 oc bracing: 21-23, 15-16
WEBS 2x4 SP No.2 *Except* 8-13,4-22,5-7,2-24,10-12: 2x6 SP No.1	JOINTS 1 Brace at Jt(s): 16, 21

REACTIONS. (size) 24=0-3-8, 12=Mechanical
 Max Horz 24=337(LC 9)
 Max Grav 24=1447(LC 21), 12=1431(LC 20)

FORCES. (lb) - Max. Comp./Max. Ten. - All forces 250 (lb) or less except when shown.
 TOP CHORD 2-4=-1379/86, 4-5=-909/258, 5-6=-58/267, 6-7=-58/260, 7-8=-918/263, 8-10=-1363/72,
 2-24=-1436/148, 10-12=-1420/87
 BOT CHORD 22-24=-371/438, 20-22=0/1931, 17-20=0/1768, 21-23=-177/298,
 19-21=-1591/0, 18-19=-1591/0, 16-18=-1591/0, 15-16=-189/334
 WEBS 13-15=0/389, 8-15=0/560, 22-23=0/415, 4-23=0/586, 5-7=-1308/380, 2-22=0/900,
 10-13=0/926, 16-17=0/619, 13-16=-1321/0, 21-22=-1311/0, 20-21=0/607

- NOTES-**
- Unbalanced roof live loads have been considered for this design.
 - Wind: ASCE 7-10; Vult=150mph Vasd=119mph; TCDL=6.0psf; BCDL=6.0psf; h=15ft; Cat. II; Exp C; Enclosed; MWFRS (envelope) and C-C Exterior(2) -0-8-2 to 3-8-11, Interior(1) 3-8-11 to 10-3-8, Exterior(2) 10-3-8 to 14-8-5, Interior(1) 14-8-5 to 20-2-12 zone;C-C for members and forces & MWFRS for reactions shown; Lumber DOL=1.60 plate grip DOL=1.60
 - This truss has been designed for a 10.0 psf bottom chord live load nonconcurrent with any other live loads.
 - * This truss has been designed for a live load of 20.0psf on the bottom chord in all areas with a clearance greater than 6'-0-0 between the bottom chord and any other members.
 - Ceiling dead load (10.0 psf) on member(s). 4-5, 7-8, 5-7; Wall dead load (5.0psf) on member(s).8-15, 4-23
 - Bottom chord live load (40.0 psf) and additional bottom chord dead load (10.0 psf) applied only to room. 21-23, 19-21, 18-19, 16-18, 15-16
 - Refer to girder(s) for truss to truss connections.
 - Attic room checked for L/360 deflection.

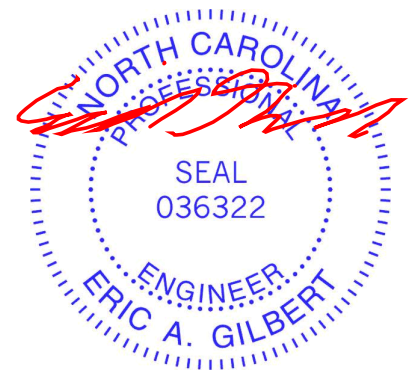

April 25, 2023

Job	Truss	Truss Type	Qty	Ply	Lot 2 West Pointe III	157942382
J0623-2991	C1GE	GABLE	1	1		

Comtech, Inc, Fayetteville, NC - 28314,

8.430 s Jan 6 2022 MiTek Industries, Inc. Mon Apr 24 12:27:47 2023 Page 1

ID:uB1kUybQLa2UVI5EAK1M8Myf?Wk-h?4pvleZ0yMxxGPobt3LwX2cD5oYQXxgH7_raZzNlVg
 0-11-0 5-2-12 8-2-1 10-3-8 12-4-15 15-4-4 20-7-0 21-6-0
 0-11-0 5-2-12 2-11-5 2-1-7 2-1-7 2-11-5 5-2-12 0-11-0

8x8 =

Scale = 1:86.5

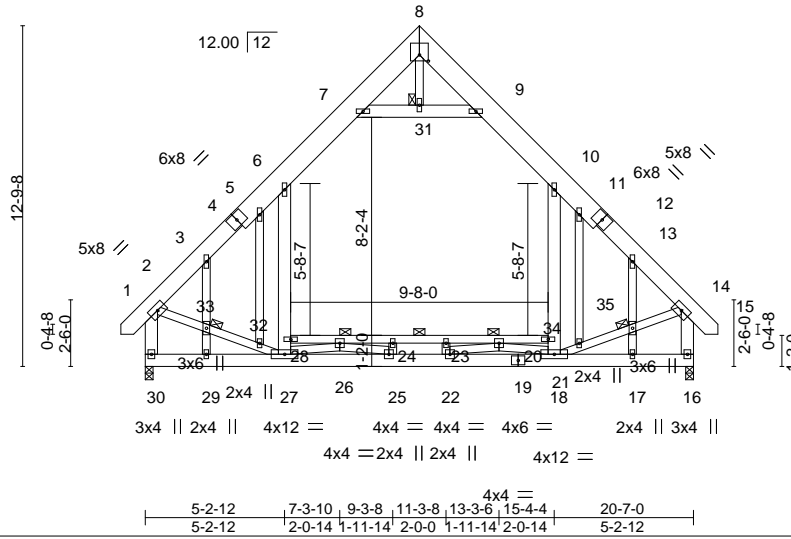

Plate Offsets (X,Y)--	[8:0-4-0-0-2-12]
-----------------------	------------------

LOADING (psf)	SPACING-	CSI.	DEFL.	in (loc)	l/defl	L/d	PLATES	GRIP
TCLL 20.0	Plate Grip DOL 1.15	TC 0.26	Vert(LL) -0.07	22-25	>999	360	MT20	244/190
TCDL 10.0	Lumber DOL 1.15	BC 0.47	Vert(CT) -0.13	22-25	>999	240		
BCLL 0.0 *	Rep Stress Incr YES	WB 0.30	Horz(CT) 0.02	16	n/a	n/a		
BCDL 10.0	Code IRC2015/TPI2014	Matrix-S	Wind(LL) 0.07	27	>999	240		
							Weight: 282 lb	FT = 20%

LUMBER-	BRACING-
TOP CHORD 2x10 SP No.1 *Except* 1-4,12-15: 2x8 SP No.1	TOP CHORD Structural wood sheathing directly applied or 6-0-0 oc purlins, except end verticals.
BOT CHORD 2x6 SP No.1 *Except* 20-28: 2x4 SP No.1	BOT CHORD Rigid ceiling directly applied or 10-0-0 oc bracing. Except: 5-0-0 oc bracing: 21-26 6-0-0 oc bracing: 26-28, 20-21
WEBS 2x4 SP No.2 *Except* 10-18,6-27,7-9,2-30,14-16: 2x6 SP No.1	JOINTS 1 Brace at Jt(s): 21, 26, 31, 33, 35
OTHERS 2x4 SP No.2	

REACTIONS. (size) 30=0-3-8, 16=0-3-8
 Max Horz 30=-433(LC 10)
 Max Uplift 30=-47(LC 13), 16=-47(LC 12)
 Max Grav 30=1451(LC 21), 16=1451(LC 20)

FORCES. (lb) - Max. Comp./Max. Ten. - All forces 250 (lb) or less except when shown.
 TOP CHORD 2-3=-1332/54, 3-5=-1396/141, 5-6=-1265/182, 6-7=-934/302, 9-10=-936/302,
 10-11=-1266/182, 11-13=-1398/141, 13-14=-1331/54, 2-30=-1345/123, 14-16=-1345/123
 BOT CHORD 29-30=-453/563, 27-29=-453/563, 25-27=0/1941, 22-25=0/2226, 18-22=0/1737,
 26-28=-220/343, 24-26=-1496/0, 23-24=-1496/0, 21-23=-1496/0, 20-21=-241/361
 WEBS 18-20=0/473, 10-20=0/644, 27-28=0/473, 6-28=0/644, 7-31=-1229/461, 9-31=-1229/461,
 2-33=0/944, 32-33=0/931, 27-32=-16/967, 18-34=-25/974, 34-35=-7/938, 14-35=-6/952,
 21-22=-22/577, 18-21=-1261/0, 26-27=-1261/0, 25-26=-27/581, 3-33=-264/115,
 13-35=-263/114

- NOTES-**
- Unbalanced roof live loads have been considered for this design.
 - Wind: ASCE 7-10; Vult=150mph Vasd=119mph; TCDL=6.0psf; BCDL=6.0psf; h=15ft; Cat. II; Exp C; Enclosed; MWFRS (envelope) gable end zone and C-C Exterior(2) zone;C-C for members and forces & MWFRS for reactions shown; Lumber DOL=1.60 plate grip DOL=1.60
 - Truss designed for wind loads in the plane of the truss only. For studs exposed to wind (normal to the face), see Standard Industry Gable End Details as applicable, or consult qualified building designer as per ANSI/TPI 1.
 - All plates are 2x6 MT20 unless otherwise indicated.
 - Gable studs spaced at 2-0-0 oc.
 - This truss has been designed for a 10.0 psf bottom chord live load nonconcurrent with any other live loads.
 - * This truss has been designed for a live load of 20.0psf on the bottom chord in all areas with a clearance greater than 6-0-0 between the bottom chord and any other members.
 - Ceiling dead load (10.0 psf) on member(s). 6-7, 9-10, 7-31, 9-31; Wall dead load (5.0psf) on member(s).10-20, 6-28
 - Bottom chord live load (40.0 psf) and additional bottom chord dead load (10.0 psf) applied only to room. 26-28, 24-26, 23-24, 21-23, 20-21
 - Provide mechanical connection (by others) of truss to bearing plate capable of withstanding 100 lb uplift at joint(s) 30, 16.
 - Attic room checked for L/360 deflection.

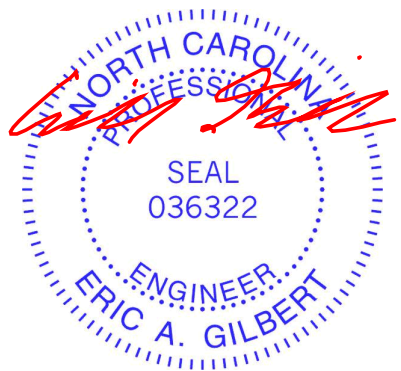

April 25, 2023

WARNING - Verify design parameters and READ NOTES ON THIS AND INCLUDED MITEK REFERENCE PAGE MII-7473 rev. 1/2/2023 BEFORE USE.
 Design valid for use only with MiTek® connectors. This design is based only upon parameters shown, and is for an individual building component, not a truss system. Before use, the building designer must verify the applicability of design parameters and properly incorporate this design into the overall building design. Bracing indicated is to prevent buckling of individual truss web and/or chord members only. Additional temporary and permanent bracing is always required for stability and to prevent collapse with possible personal injury and property damage. For general guidance regarding the fabrication, storage, delivery, erection and bracing of trusses and truss systems, see **ANSI/TPI1 Quality Criteria and DSB-22** available from Truss Plate Institute (www.tpinst.org) and **BCSI Building Component Safety Information** available from the Structural Building Component Association (www.sbcacomponents.com)

TRENCO ENGINEERING BY
 A MiTek Affiliate
 818 Soundside Road
 Edenton, NC 27932

Job	Truss	Truss Type	Qty	Ply	Lot 2 West Pointe III	157942383
J0623-2991	D1	COMMON	6	1	Job Reference (optional)	

Comtech, Inc. Fayetteville, NC - 28314,

8.430 s Jan 6 2022 MiTek Industries, Inc. Mon Apr 24 12:27:49 2023 Page 1

ID:uB1kUybQLa2UVI5EAK1M8Myf?Wk-dOCZKRgpYZcfBZYAjI6p?y7zavXsuSizIRTYeSzNvle

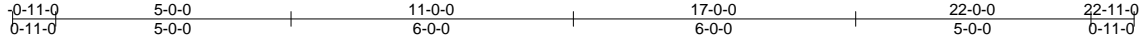

5x5 =

Scale = 1:49.0

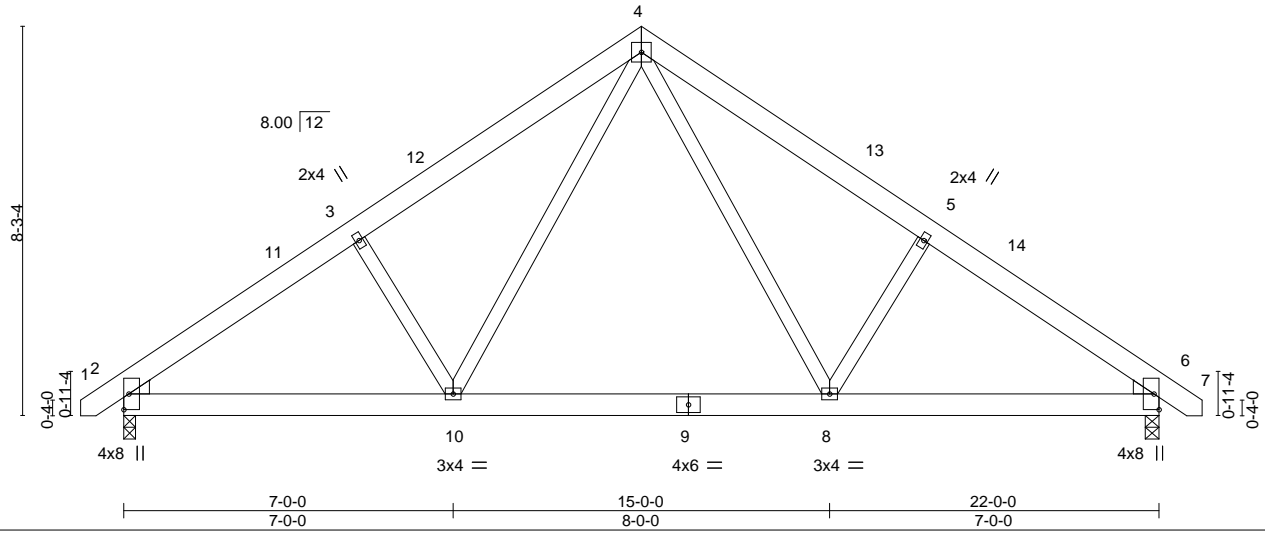

LOADING (psf)	SPACING-	CSI.	DEFL.	in	(loc)	l/defl	L/d	PLATES	GRIP
TCLL 20.0	2-0-0	TC 0.21	Vert(LL)	-0.06	8-10	>999	360	MT20	244/190
TCDL 10.0	Plate Grip DOL 1.15	BC 0.25	Vert(CT)	-0.10	8-10	>999	240		
BCLL 0.0 *	Lumber DOL 1.15	WB 0.24	Horz(CT)	0.02	6	n/a	n/a		
BCDL 10.0	Rep Stress Incr YES	Matrix-S	Wind(LL)	0.02	10	>999	240		
	Code IRC2015/TPI2014							Weight: 157 lb	FT = 20%

LUMBER-

TOP CHORD 2x6 SP No.1
 BOT CHORD 2x6 SP No.1
 WEBS 2x4 SP No.2
 WEDGE

Left: 2x4 SP No.3 , Right: 2x4 SP No.3

BRACING-

TOP CHORD Structural wood sheathing directly applied or 6-0-0 oc purlins.
 BOT CHORD Rigid ceiling directly applied or 10-0-0 oc bracing.

REACTIONS.

(size) 2=0-3-0, 6=0-3-8
 Max Horz 2=-250(LC 10)
 Max Uplift 2=-165(LC 12), 6=-166(LC 13)
 Max Grav 2=992(LC 19), 6=993(LC 20)

FORCES. (lb) - Max. Comp./Max. Ten. - All forces 250 (lb) or less except when shown.

TOP CHORD 2-3=-1331/460, 3-4=-1287/530, 4-5=-1285/529, 5-6=-1329/459
 BOT CHORD 2-10=-259/1171, 8-10=-277/58, 6-8=-260/986
 WEBS 4-8=-185/600, 5-8=-379/297, 4-10=-186/603, 3-10=-382/299

NOTES-

- Unbalanced roof live loads have been considered for this design.
- Wind: ASCE 7-10; Vult=150mph Vasd=119mph; TCDL=6.0psf; BCDL=6.0psf; h=15ft; Cat. II; Exp C; Enclosed; MWFRS (envelope) and C-C Exterior(2) -0-9-1 to 3-7-12, Interior(1) 3-7-12 to 11-0-0, Exterior(2) 11-0-0 to 15-4-13, Interior(1) 15-4-13 to 22-9-1 zone; C-C for members and forces & MWFRS for reactions shown; Lumber DOL=1.60 plate grip DOL=1.60
- This truss has been designed for a 10.0 psf bottom chord live load nonconcurrent with any other live loads.
- * This truss has been designed for a live load of 20.0psf on the bottom chord in all areas with a clearance greater than 6-0-0 between the bottom chord and any other members, with BCDL = 10.0psf.
- Provide mechanical connection (by others) of truss to bearing plate capable of withstanding 100 lb uplift at joint(s) except (jt=lb) 2=165, 6=166.

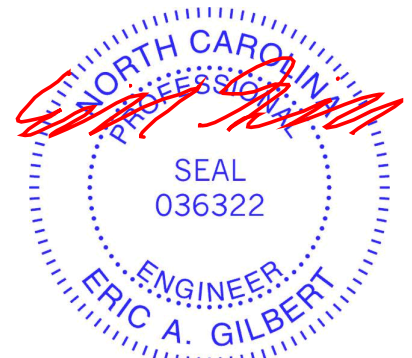

April 25, 2023

WARNING - Verify design parameters and READ NOTES ON THIS AND INCLUDED MITEK REFERENCE PAGE MII-7473 rev. 1/2/2023 BEFORE USE.

Design valid for use only with MiTek® connectors. This design is based only upon parameters shown, and is for an individual building component, not a truss system. Before use, the building designer must verify the applicability of design parameters and properly incorporate this design into the overall building design. Bracing indicated is to prevent buckling of individual truss web and/or chord members only. Additional temporary and permanent bracing is always required for stability and to prevent collapse with possible personal injury and property damage. For general guidance regarding the fabrication, storage, delivery, erection and bracing of trusses and truss systems, see **ANSI/TPH Quality Criteria and DSB-22** available from Truss Plate Institute (www.tpinst.org) and **BCSI Building Component Safety Information** available from the Structural Building Component Association (www.sbcacomponents.com)



818 Soundside Road
 Edenton, NC 27932

Job	Truss	Truss Type	Qty	Ply	Lot 2 West Pointe III	157942384
J0623-2991	D1-GR	COMMON GIRDER	1	2	Job Reference (optional)	

Comtech, Inc., Fayetteville, NC - 28314,

8.430 s Jan 6 2022 MiTek Industries, Inc. Mon Apr 24 12:27:53 2023 Page 1
 ID:uB1kUybQLa2UVI5EAk1M8Myf?Wk-W9R49ojKbo64fBsyy8AI9olVoWozq9aYg3R9nDzNVla

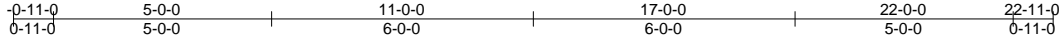

5x8 ||

Scale = 1:52.8

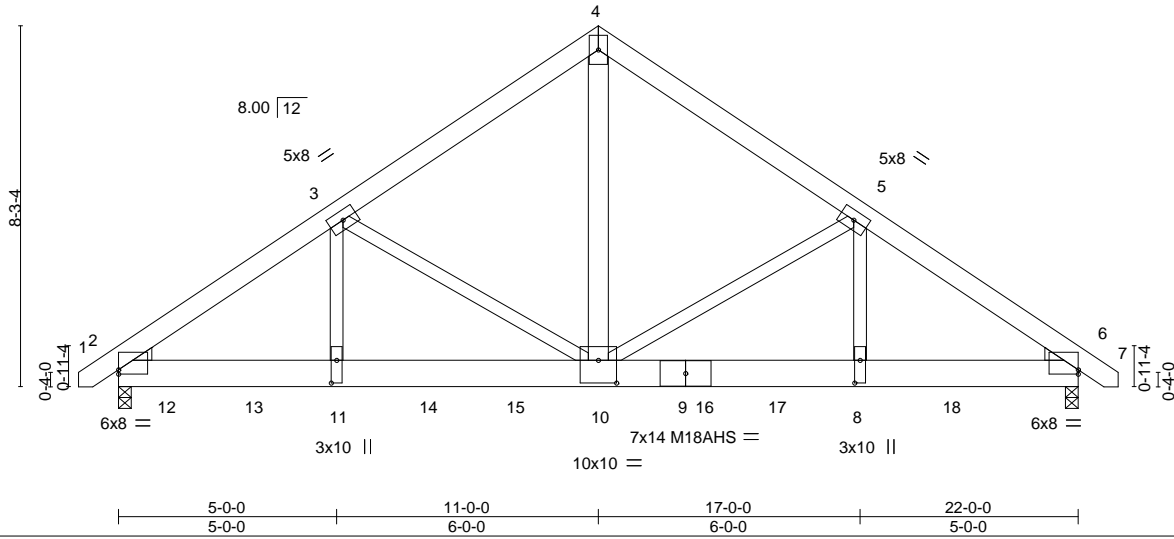

Plate Offsets (X,Y)-- [2:0-0-0,0-1-3], [6:Edge,0-1-3], [8:0-6-4,0-1-8], [10:0-5-0,0-6-4], [11:0-6-4,0-1-8]

LOADING (psf)	SPACING-	CSI.	DEFL.	in (loc)	l/defl	L/d	PLATES	GRIP
TCLL 20.0	Plate Grip DOL 1.15	TC 0.90	Vert(LL) -0.11	8-10	>999	360	MT20	244/190
TCDL 10.0	Lumber DOL 1.15	BC 0.69	Vert(CT) -0.24	8-10	>999	240	M18AHS	186/179
BCLL 0.0 *	Rep Stress Incr NO	WB 0.67	Horz(CT) 0.06	6	n/a	n/a		
BCDL 10.0	Code IRC2015/TPI2014	Matrix-S	Wind(LL) -0.01	10-11	>999	240		
							Weight: 365 lb	FT = 20%

LUMBER-

TOP CHORD 2x6 SP No.1
 BOT CHORD 2x8 SP 2400F 2.0E
 WEBS 2x4 SP No.2 *Except*
 4-10: 2x6 SP No.1

WEDGE

Left: 2x4 SP No.3, Right: 2x4 SP No.3

REACTIONS.

(size) 2=0-3-8 (req. 0-3-12), 6=0-3-8 (req. 0-3-9)
 Max Horz 2=-250(LC 6)
 Max Grav 2=9036(LC 2), 6=8631(LC 2)

FORCES. (lb) - Max. Comp./Max. Ten. - All forces 250 (lb) or less except when shown.

TOP CHORD 2-3=-12011/0, 3-4=-8814/0, 4-5=-8806/0, 5-6=-13239/0
 BOT CHORD 2-11=0/9538, 10-11=0/9538, 8-10=0/10487, 6-8=0/10487
 WEBS 4-10=0/9342, 5-10=-3768/0, 5-8=0/4868, 3-10=-2654/0, 3-11=0/3490

NOTES-

- 2-ply truss to be connected together with 10d (0.131"x3") nails as follows:
 Top chords connected as follows: 2x6 - 2 rows staggered at 0-9-0 oc.
 Bottom chords connected as follows: 2x8 - 2 rows staggered at 0-5-0 oc.
 Webs connected as follows: 2x6 - 2 rows staggered at 0-9-0 oc, 2x4 - 1 row at 0-9-0 oc.
- All loads are considered equally applied to all plies, except if noted as front (F) or back (B) face in the LOAD CASE(S) section. Ply to ply connections have been provided to distribute only loads noted as (F) or (B), unless otherwise indicated.
- Unbalanced roof live loads have been considered for this design.
- Wind: ASCE 7-10; Vult=150mph Vasd=119mph; TCDL=6.0psf; BCDL=6.0psf; h=15ft; Cat. II; Exp C; Enclosed; MWFRS (envelope); Lumber DOL=1.60 plate grip DOL=1.60
- All plates are MT20 plates unless otherwise indicated.
- This truss has been designed for a 10.0 psf bottom chord live load nonconcurrent with any other live loads.
- * This truss has been designed for a live load of 20.0psf on the bottom chord in all areas with a clearance greater than 6-0-0 between the bottom chord and any other members.
- WARNING: Required bearing size at joint(s) 2, 6 greater than input bearing size.
- Hanger(s) or other connection device(s) shall be provided sufficient to support concentrated load(s) 1400 lb down at 1-0-12, 1353 lb down at 3-0-12, 1353 lb down at 5-0-12, 1353 lb down at 7-0-12, 1353 lb down at 9-0-12, 1353 lb down at 11-0-12, 1353 lb down at 13-0-12, 1616 lb down at 13-4-12, 1641 lb down at 15-0-12, and 1641 lb down at 17-0-12, and 1641 lb down at 19-0-12 on bottom chord. The design/selection of such connection device(s) is the responsibility of others.

LOAD CASE(S) Standard

- 1) Dead + Roof Live (balanced): Lumber Increase=1.15, Plate Increase=1.15



April 25, 2023

Continued on page 2

WARNING - Verify design parameters and READ NOTES ON THIS AND INCLUDED MITEK REFERENCE PAGE MII-7473 rev. 1/2/2023 BEFORE USE.

Design valid for use only with MiTek® connectors. This design is based only upon parameters shown, and is for an individual building component, not a truss system. Before use, the building designer must verify the applicability of design parameters and properly incorporate this design into the overall building design. Bracing indicated is to prevent buckling of individual truss web and/or chord members only. Additional temporary and permanent bracing is always required for stability and to prevent collapse with possible personal injury and property damage. For general guidance regarding the fabrication, storage, delivery, erection and bracing of trusses and truss systems, see **ANSI/TP1 Quality Criteria and DSB-22** available from Truss Plate Institute (www.tpinst.org) and **BCSI Building Component Safety Information** available from the Structural Building Component Association (www.sbcacomponents.com)



818 Soundside Road
 Edenton, NC 27932

Job	Truss	Truss Type	Qty	Ply	Lot 2 West Pointe III	I57942384
J0623-2991	D1-GR	COMMON GIRDER	1	2	Job Reference (optional)	

Comtech, Inc, Fayetteville, NC - 28314,

8.430 s Jan 6 2022 MiTek Industries, Inc. Mon Apr 24 12:27:53 2023 Page 2
 ID:uB1kUybQLa2UVI5EAk1M8Myf?Wk-W9R49ojKbo64fBsyy8Al9olVoWozq9aYg3R9nDzNVla

LOAD CASE(S) Standard

Uniform Loads (plf)

Vert: 1-4=-60, 4-7=-60, 2-6=-20

Concentrated Loads (lb)

Vert: 9=-1150(B) 10=-1150(B) 8=-1400(B) 11=-1150(B) 12=-1206(B) 13=-1150(B) 14=-1150(B) 15=-1150(B) 16=-1377(B) 17=-1400(B) 18=-1400(B)

WARNING - Verify design parameters and READ NOTES ON THIS AND INCLUDED MITEK REFERENCE PAGE MII-7473 rev. 1/2/2023 BEFORE USE.

Design valid for use only with MiTek® connectors. This design is based only upon parameters shown, and is for an individual building component, not a truss system. Before use, the building designer must verify the applicability of design parameters and properly incorporate this design into the overall building design. Bracing indicated is to prevent buckling of individual truss web and/or chord members only. Additional temporary and permanent bracing is always required for stability and to prevent collapse with possible personal injury and property damage. For general guidance regarding the fabrication, storage, delivery, erection and bracing of trusses and truss systems, see **ANSI/TP1 Quality Criteria and DSB-22** available from Truss Plate Institute (www.tpinst.org) and **BCSI Building Component Safety Information** available from the Structural Building Component Association (www.sbcacomponents.com)



818 Soundside Road
 Edenton, NC 27932

Job	Truss	Truss Type	Qty	Ply	Lot 2 West Pointe III	157942385
J0623-2991	D1GE	GABLE	1	1	Job Reference (optional)	

Comtech, Inc., Fayetteville, NC - 28314,

8.430 s Jan 6 2022 MiTek Industries, Inc. Mon Apr 24 12:27:51 2023 Page 1
 ID:uB1kUybQLa2UVI5EAk1M8Myf?Wk-anJKI7h43BsMQtiZqi8H4NCMciGuMNUFClyzjKzNVlc

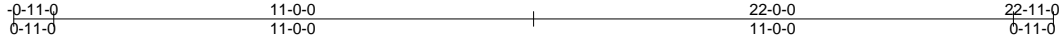

5x5 =

Scale = 1:52.8

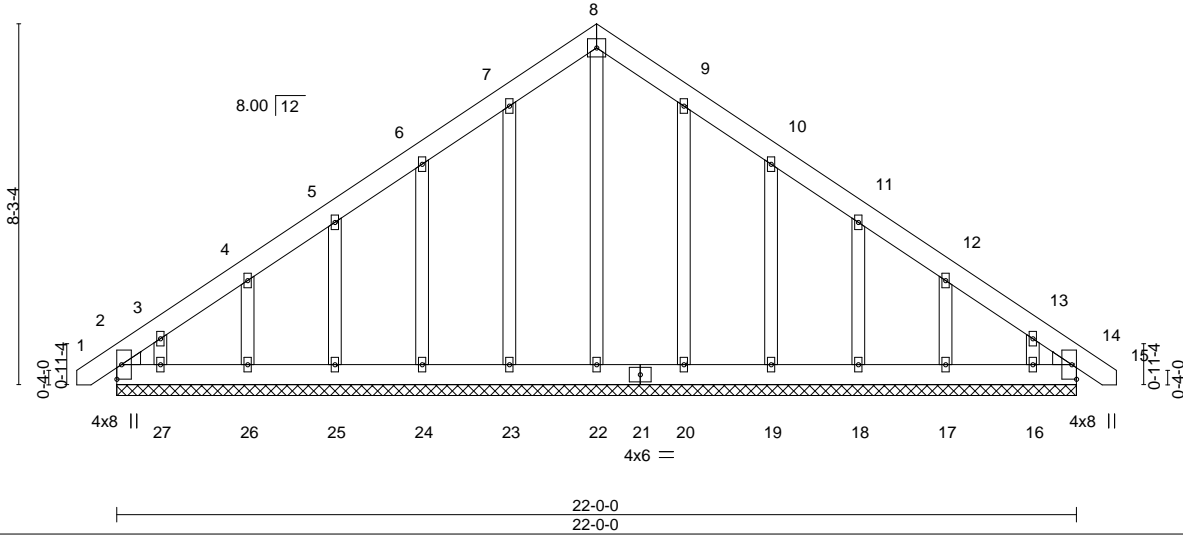

LOADING (psf)	SPACING-	2-0-0	CSI.	DEFL.	in	(loc)	l/defl	L/d	PLATES	GRIP
TCLL 20.0	Plate Grip DOL	1.15	TC 0.04	Vert(LL)	-0.00	14	n/r	120	MT20	244/190
TCDL 10.0	Lumber DOL	1.15	BC 0.02	Vert(CT)	-0.00	14	n/r	120		
BCLL 0.0 *	Rep Stress Incr	YES	WB 0.17	Horz(CT)	0.00	14	n/a	n/a		
BCDL 10.0	Code IRC2015/TPI2014		Matrix-S						Weight: 181 lb	FT = 20%

LUMBER-

TOP CHORD 2x6 SP No.1
 BOT CHORD 2x6 SP No.1
 OTHERS 2x4 SP No.2
 WEDGE

Left: 2x4 SP No.3 , Right: 2x4 SP No.3

BRACING-

TOP CHORD Structural wood sheathing directly applied or 6-0-0 oc purlins.
 BOT CHORD Rigid ceiling directly applied or 10-0-0 oc bracing.

REACTIONS.

All bearings 22-0-0.
 (lb) - Max Horz 2=-313(LC 20)
 Max Uplift All uplift 100 lb or less at joint(s) 14, 20 except 2=-148(LC 8), 23=-108(LC 12), 24=-144(LC 12), 25=-129(LC 12), 26=-142(LC 12), 27=-207(LC 12), 19=-147(LC 13), 18=-130(LC 13), 17=-140(LC 13), 16=-186(LC 13)
 Max Grav All reactions 250 lb or less at joint(s) 2, 14, 23, 24, 25, 26, 27, 20, 19, 18, 17, 16 except 22=258(LC 22)

FORCES. (lb) - Max. Comp./Max. Ten. - All forces 250 (lb) or less except when shown.

TOP CHORD 2-3=-373/270, 7-8=-246/270, 8-9=-246/270, 13-14=-294/189

NOTES-

- Unbalanced roof live loads have been considered for this design.
- Wind: ASCE 7-10; Vult=150mph Vasd=119mph; TCDL=6.0psf; BCDL=6.0psf; h=15ft; Cat. II; Exp C; Enclosed; MWFRS (envelope) gable end zone and C-C Exterior(2) zone; C-C for members and forces & MWFRS for reactions shown; Lumber DOL=1.60 plate grip DOL=1.60
- Truss designed for wind loads in the plane of the truss only. For studs exposed to wind (normal to the face), see Standard Industry Gable End Details as applicable, or consult qualified building designer as per ANSI/TPI 1.
- All plates are 2x4 MT20 unless otherwise indicated.
- Gable requires continuous bottom chord bearing.
- Gable studs spaced at 2-0-0 oc.
- This truss has been designed for a 10.0 psf bottom chord live load nonconcurrent with any other live loads.
- * This truss has been designed for a live load of 20.0psf on the bottom chord in all areas with a clearance greater than 6-0-0 between the bottom chord and any other members, with BCDL = 10.0psf.
- Provide mechanical connection (by others) of truss to bearing plate capable of withstanding 100 lb uplift at joint(s) 14, 20 except (jt=lb) 2=148, 23=108, 24=144, 25=129, 26=142, 27=207, 19=147, 18=130, 17=140, 16=186.

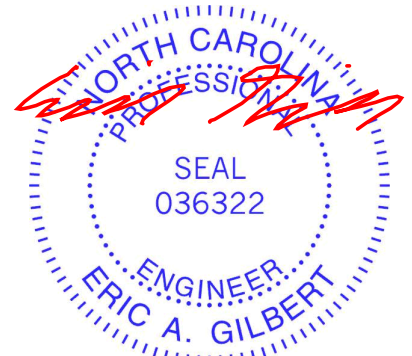

April 25, 2023

WARNING - Verify design parameters and READ NOTES ON THIS AND INCLUDED MITEK REFERENCE PAGE MII-7473 rev. 1/2/2023 BEFORE USE.

Design valid for use only with MiTek® connectors. This design is based only upon parameters shown, and is for an individual building component, not a truss system. Before use, the building designer must verify the applicability of design parameters and properly incorporate this design into the overall building design. Bracing indicated is to prevent buckling of individual truss web and/or chord members only. Additional temporary and permanent bracing is always required for stability and to prevent collapse with possible personal injury and property damage. For general guidance regarding the fabrication, storage, delivery, erection and bracing of trusses and truss systems, see **ANSI/TPI1 Quality Criteria and DSB-22** available from Truss Plate Institute (www.tpinst.org) and **BCSI Building Component Safety Information** available from the Structural Building Component Association (www.sbcacomponents.com)



818 Soundside Road
 Edenton, NC 27932

Job	Truss	Truss Type	Qty	Ply	Lot 2 West Pointe III	157942386
J0623-2991	G1	COMMON	4	1		

Comtech, Inc, Fayetteville, NC - 28314,

8.430 s Jan 6 2022 MiTek Industries, Inc. Mon Apr 24 12:27:54 2023 Page 1

ID:uB1kUybQLa2UVI5EAk1M8Myf?Wk-_M?SN8kyM6ExHKR8Vri_i0qoYwG4ZiHujAiKfzNVIZ
11-11-0 12-10-0
5-11-8 0-11-0

Scale = 1:22.1

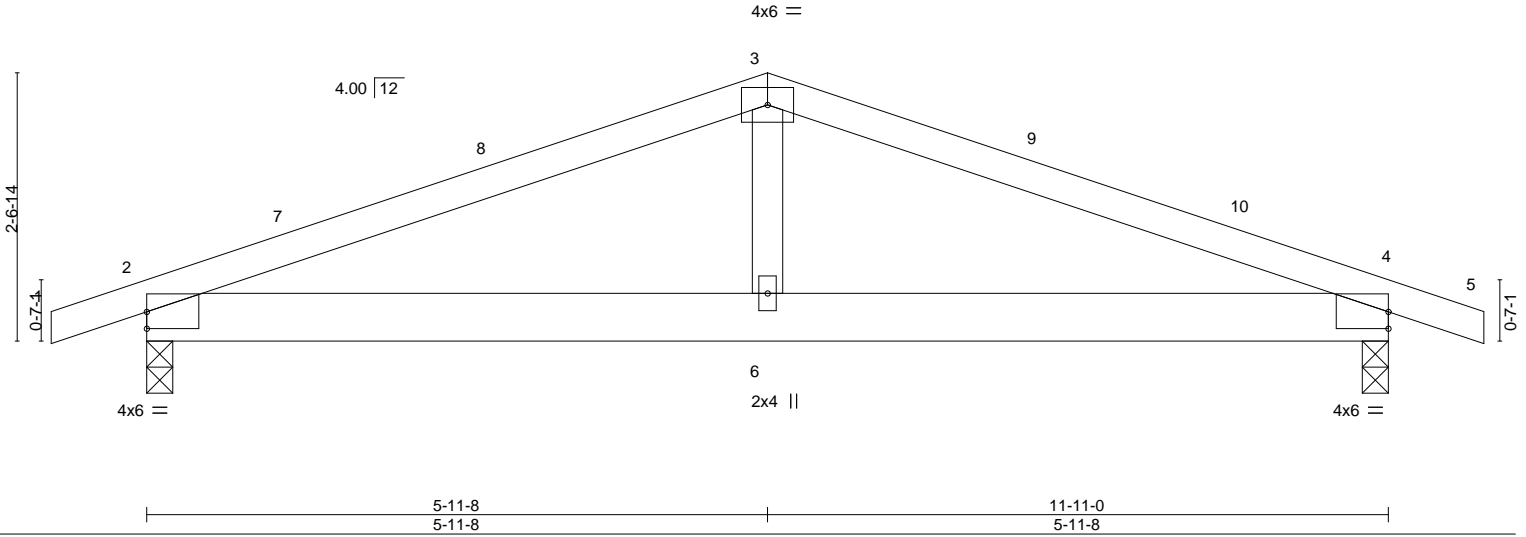

Plate Offsets (X,Y)-- [2:0-0-0,0-1-15], [4:0-0-0,0-1-15]

LOADING (psf)	SPACING-	CSI.	DEFL.	in (loc)	l/defl	L/d	PLATES	GRIP
TCLL 20.0	Plate Grip DOL 1.15	TC 0.38	Vert(LL) 0.05	2-6	>999	240	MT20	244/190
TCDL 10.0	Lumber DOL 1.15	BC 0.18	Vert(CT) -0.03	2-6	>999	240		
BCLL 0.0 *	Rep Stress Incr YES	WB 0.07	Horz(CT) -0.01	4	n/a	n/a		
BCDL 10.0	Code IRC2015/TPI2014	Matrix-S					Weight: 52 lb	FT = 20%

LUMBER-

TOP CHORD 2x4 SP No.1
BOT CHORD 2x6 SP No.1
WEBS 2x4 SP No.2

BRACING-

TOP CHORD Structural wood sheathing directly applied or 6-0-0 oc purlins.
BOT CHORD Rigid ceiling directly applied or 7-3-12 oc bracing.

REACTIONS.

(size) 2=0-3-0, 4=0-3-0
Max Horz 2=37(LC 12)
Max Uplift 2=-324(LC 8), 4=-324(LC 9)
Max Grav 2=529(LC 1), 4=529(LC 1)

FORCES. (lb) - Max. Comp./Max. Ten. - All forces 250 (lb) or less except when shown.

TOP CHORD 2-3=-805/1227, 3-4=-805/1227
BOT CHORD 2-6=-1046/693, 4-6=-1046/693
WEBS 3-6=-536/290

NOTES-

- Unbalanced roof live loads have been considered for this design.
- Wind: ASCE 7-10; Vult=150mph Vasd=119mph; TCDL=6.0psf; BCDL=6.0psf; h=15ft; Cat. II; Exp C; Enclosed; MWFRS (envelope) and C-C Exterior(2) -0-11-0 to 3-5-13, Interior(1) 3-5-13 to 5-11-8, Exterior(2) 5-11-8 to 10-4-5, Interior(1) 10-4-5 to 12-10-0 zone; porch left and right exposed; C-C for members and forces & MWFRS for reactions shown; Lumber DOL=1.60 plate grip DOL=1.60
- This truss has been designed for a 10.0 psf bottom chord live load nonconcurrent with any other live loads.
- * This truss has been designed for a live load of 20.0psf on the bottom chord in all areas with a clearance greater than 6-0-0 between the bottom chord and any other members.
- Provide mechanical connection (by others) of truss to bearing plate capable of withstanding 100 lb uplift at joint(s) except (jt=lb) 2=324, 4=324.

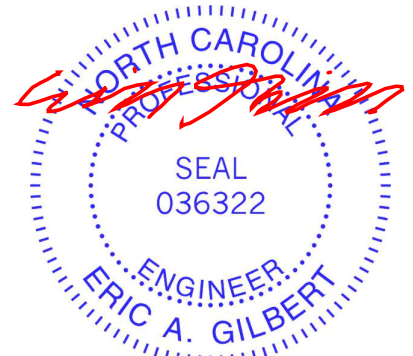

April 25, 2023

WARNING - Verify design parameters and READ NOTES ON THIS AND INCLUDED MITEK REFERENCE PAGE MII-7473 rev. 1/2/2023 BEFORE USE.

Design valid for use only with MiTek® connectors. This design is based only upon parameters shown, and is for an individual building component, not a truss system. Before use, the building designer must verify the applicability of design parameters and properly incorporate this design into the overall building design. Bracing indicated is to prevent buckling of individual truss web and/or chord members only. Additional temporary and permanent bracing is always required for stability and to prevent collapse with possible personal injury and property damage. For general guidance regarding the fabrication, storage, delivery, erection and bracing of trusses and truss systems, see **ANSI/TPH Quality Criteria and DSB-22** available from Truss Plate Institute (www.tpinst.org) and **BCSI Building Component Safety Information** available from the Structural Building Component Association (www.sbcacomponents.com)



818 Soundside Road
Edenton, NC 27932

Job	Truss	Truss Type	Qty	Ply	Lot 2 West Pointe III	157942387
J0623-2991	G1GE	GABLE	1	1		

Comtech, Inc., Fayetteville, NC - 28314,

8.430 s Jan 6 2022 MiTek Industries, Inc. Mon Apr 24 12:27:56 2023 Page 1

ID:uB1kUybQLa2UVI5EAK1M8Myf?Wk-wk7DoqICujVfWebXdGkSnRwAnjxX1ef?M1fpOYZNVIX

Job Reference (optional)

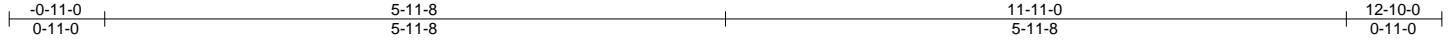

Scale = 1:22.1

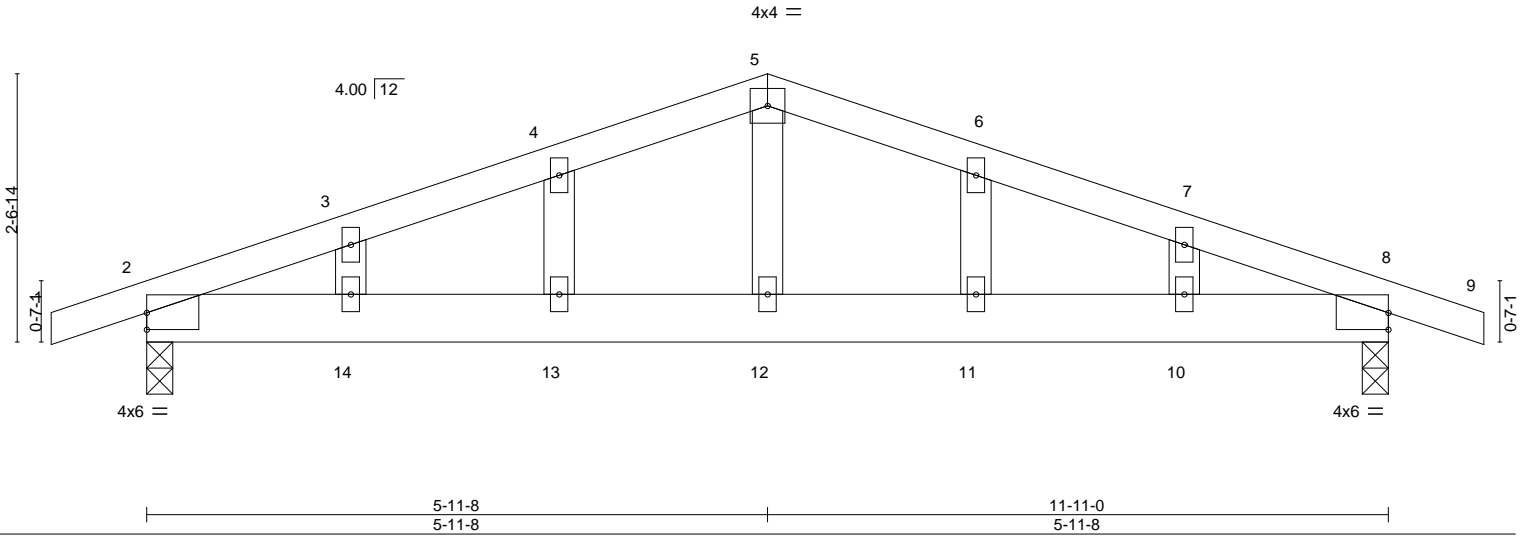

Plate Offsets (X,Y)-- [2:0-0-0,0-1-15], [8:0-0-0,0-1-15]

LOADING (psf)	SPACING-	CSI.	DEFL.	PLATES	GRIP
TCLL 20.0	Plate Grip DOL 1.15	TC 0.21	Vert(LL) 0.04 11 >999 240	MT20	244/190
TCDL 10.0	Lumber DOL 1.15	BC 0.19	Vert(CT) -0.03 13-14 >999 240		
BCLL 0.0 *	Rep Stress Incr YES	WB 0.07	Horz(CT) -0.01 8 n/a n/a		
BCDL 10.0	Code IRC2015/TPI2014	Matrix-S		Weight: 57 lb	FT = 20%

LUMBER-
 TOP CHORD 2x4 SP No.1
 BOT CHORD 2x6 SP No.1
 WEBS 2x4 SP No.2
 OTHERS 2x4 SP No.2

BRACING-
 TOP CHORD Structural wood sheathing directly applied or 6-0-0 oc purlins.
 BOT CHORD Rigid ceiling directly applied or 7-2-11 oc bracing.

REACTIONS. (size) 2=0-3-0, 8=0-3-0
 Max Horz 2=62(LC 12)
 Max Uplift 2=440(LC 8), 8=440(LC 9)
 Max Grav 2=529(LC 1), 8=529(LC 1)

FORCES. (lb) - Max. Comp./Max. Ten. - All forces 250 (lb) or less except when shown.
 TOP CHORD 2-3=-792/1272, 3-4=-745/1266, 4-5=-738/1308, 5-6=-738/1308, 6-7=-745/1266,
 7-8=-792/1272
 BOT CHORD 2-14=-1099/692, 13-14=-1099/692, 12-13=-1099/692, 11-12=-1099/692, 10-11=-1099/692,
 8-10=-1099/692
 WEBS 5-12=-621/301

- NOTES-**
- Unbalanced roof live loads have been considered for this design.
 - Wind: ASCE 7-10; Vult=150mph Vasd=119mph; TCDL=6.0psf; BCDL=6.0psf; h=15ft; Cat. II; Exp C; Enclosed; MWFRS (envelope) gable end zone and C-C Exterior(2) zone; porch left and right exposed;C-C for members and forces & MWFRS for reactions shown; Lumber DOL=1.60 plate grip DOL=1.60
 - Truss designed for wind loads in the plane of the truss only. For studs exposed to wind (normal to the face), see Standard Industry Gable End Details as applicable, or consult qualified building designer as per ANSI/TPI 1.
 - All plates are 2x4 MT20 unless otherwise indicated.
 - Gable studs spaced at 2-0-0 oc.
 - This truss has been designed for a 10.0 psf bottom chord live load nonconcurrent with any other live loads.
 - * This truss has been designed for a live load of 20.0psf on the bottom chord in all areas with a clearance greater than 6-0-0 between the bottom chord and any other members.
 - Provide mechanical connection (by others) of truss to bearing plate capable of withstanding 100 lb uplift at joint(s) except (jt=lb) 2=440, 8=440.

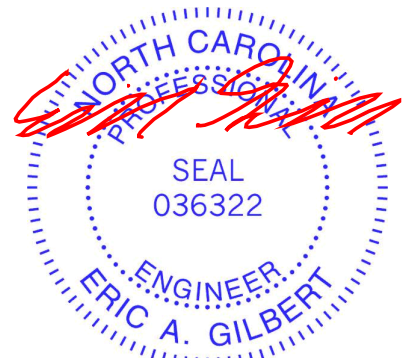

April 25, 2023

WARNING - Verify design parameters and READ NOTES ON THIS AND INCLUDED MITEK REFERENCE PAGE MII-7473 rev. 1/2/2023 BEFORE USE.
 Design valid for use only with MiTek® connectors. This design is based only upon parameters shown, and is for an individual building component, not a truss system. Before use, the building designer must verify the applicability of design parameters and properly incorporate this design into the overall building design. Bracing indicated is to prevent buckling of individual truss web and/or chord members only. Additional temporary and permanent bracing is always required for stability and to prevent collapse with possible personal injury and property damage. For general guidance regarding the fabrication, storage, delivery, erection and bracing of trusses and truss systems, see **ANSI/TPI1 Quality Criteria and DSB-22** available from Truss Plate Institute (www.tpinst.org) and **BCSI Building Component Safety Information** available from the Structural Building Component Association (www.sbcacomponents.com)



818 Soundside Road
 Edenton, NC 27932

Job	Truss	Truss Type	Qty	Ply	Lot 2 West Pointe III	157942388
J0623-2991	H1GE	COMMON SUPPORTED GAB	1	1	Job Reference (optional)	

Comtech, Inc., Fayetteville, NC - 28314,

8.430 s Jan 6 2022 MiTek Industries, Inc. Mon Apr 24 12:27:57 2023 Page 1

ID:uB1kUybQLa2UVI5EAK1M8Myf?Wk-Oxgb?Amr1dW8oAjBzFhKeSNO7JSm6Z8ahPNw_zNVIW

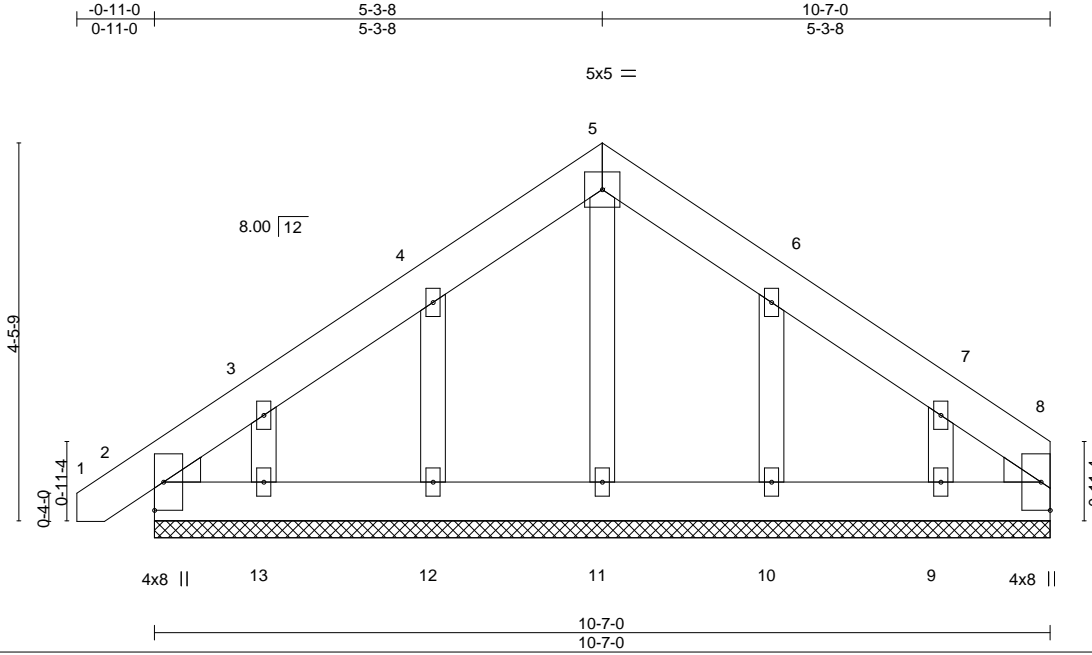

Scale = 1:27.2

LOADING (psf)	SPACING-	CSI.	DEFL.	in (loc)	l/defl	L/d	PLATES	GRIP
TCLL 20.0	2-0-0	TC 0.02	Vert(LL)	-0.00	1	n/r	MT20	244/190
TCDL 10.0	Plate Grip DOL 1.15	BC 0.01	Vert(CT)	-0.00	1	n/r		
BCLL 0.0 *	Lumber DOL 1.15	WB 0.03	Horz(CT)	0.00	8	n/a		
BCDL 10.0	Rep Stress Incr YES	Matrix-S					Weight: 74 lb	FT = 20%
	Code IRC2015/TPI2014							

LUMBER-

TOP CHORD 2x6 SP No.1
 BOT CHORD 2x6 SP No.1
 OTHERS 2x4 SP No.2
 WEDGE

Left: 2x4 SP No.3 , Right: 2x4 SP No.3

BRACING-

TOP CHORD Structural wood sheathing directly applied or 6-0-0 oc purlins.
 BOT CHORD Rigid ceiling directly applied or 10-0-0 oc bracing.

REACTIONS.

All bearings 10-7-0.
 (lb) - Max Horz 2=160(LC 11)
 Max Uplift All uplift 100 lb or less at joint(s) 2, 8 except 12=134(LC 12), 13=154(LC 12), 10=129(LC 13), 9=159(LC 13)
 Max Grav All reactions 250 lb or less at joint(s) 2, 11, 12, 13, 10, 9, 8

FORCES. (lb) - Max. Comp./Max. Ten. - All forces 250 (lb) or less except when shown.

NOTES-

- Unbalanced roof live loads have been considered for this design.
- Wind: ASCE 7-10; Vult=150mph Vasd=119mph; TCDL=6.0psf; BCDL=6.0psf; h=15ft; Cat. II; Exp C; Enclosed; MWFRS (envelope) gable end zone and C-C Exterior(2) zone;C-C for members and forces & MWFRS for reactions shown; Lumber DOL=1.60 plate grip DOL=1.60
- Truss designed for wind loads in the plane of the truss only. For studs exposed to wind (normal to the face), see Standard Industry Gable End Details as applicable, or consult qualified building designer as per ANSI/TPI 1.
- All plates are 2x4 MT20 unless otherwise indicated.
- Gable requires continuous bottom chord bearing.
- Gable studs spaced at 2-0-0 oc.
- This truss has been designed for a 10.0 psf bottom chord live load nonconcurrent with any other live loads.
- * This truss has been designed for a live load of 20.0psf on the bottom chord in all areas with a clearance greater than 6-0-0 between the bottom chord and any other members.
- Provide mechanical connection (by others) of truss to bearing plate capable of withstanding 100 lb uplift at joint(s) 2, 8 except (jt=lb) 12=134, 13=154, 10=129, 9=159.
- Beveled plate or shim required to provide full bearing surface with truss chord at joint(s) 8.



April 25, 2023

WARNING - Verify design parameters and READ NOTES ON THIS AND INCLUDED MITEK REFERENCE PAGE MII-7473 rev. 1/2/2023 BEFORE USE.

Design valid for use only with MiTek® connectors. This design is based only upon parameters shown, and is for an individual building component, not a truss system. Before use, the building designer must verify the applicability of design parameters and properly incorporate this design into the overall building design. Bracing indicated is to prevent buckling of individual truss web and/or chord members only. Additional temporary and permanent bracing is always required for stability and to prevent collapse with possible personal injury and property damage. For general guidance regarding the fabrication, storage, delivery, erection and bracing of trusses and truss systems, see **ANSI/TPI1 Quality Criteria and DSB-22** available from Truss Plate Institute (www.tpinst.org) and **BCSI Building Component Safety Information** available from the Structural Building Component Association (www.sbcacomponents.com)



818 Soundside Road
 Edenton, NC 27932

Job	Truss	Truss Type	Qty	Ply	Lot 2 West Pointe III	157942389
J0623-2991	M1	MONOPITCH	4	1		

Comtech, Inc, Fayetteville, NC - 28314,

8.430 s Jan 6 2022 MiTek Industries, Inc. Mon Apr 24 12:27:59 2023 Page 1

ID:uB1kUybQLa2UVI5EAk1M8Myf?Wk-LJoLQso5BetEN6J5IOH9P3YdYxvAE0XR2?uT?tzNVIU

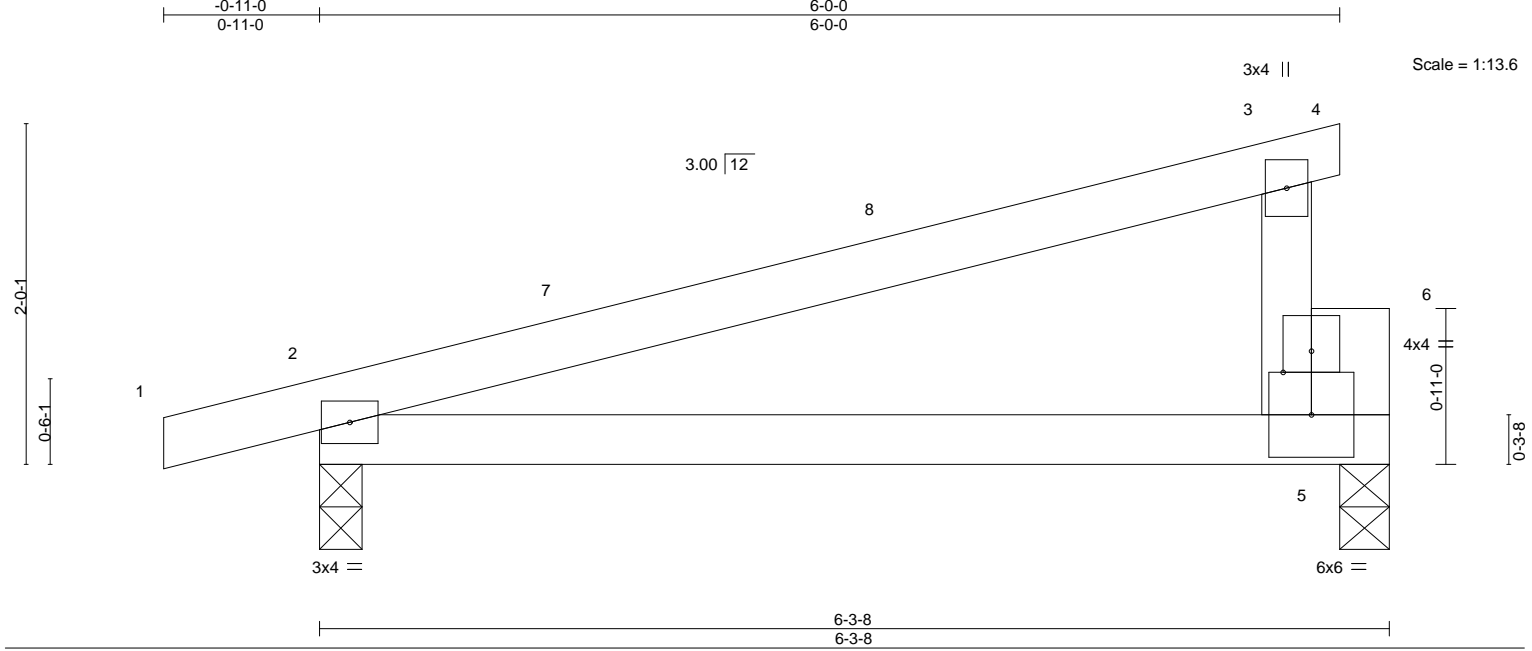

Plate Offsets (X,Y)-- [6:0-2-0,0-1-8] 6-3-8 6-3-8

LOADING (psf)	SPACING-	CSL.	DEFL.	in (loc)	l/defl	L/d	PLATES	GRIP
TCLL 20.0	Plate Grip DOL 1.15	TC 0.43	Vert(LL) 0.17	2-5	>399	240	MT20	244/190
TCDL 10.0	Lumber DOL 1.15	BC 0.45	Vert(CT) -0.12	2-5	>589	240		
BCLL 0.0 *	Rep Stress Incr YES	WB 0.00	Horz(CT) -0.00	5	n/a	n/a		
BCDL 10.0	Code IRC2015/TPI2014	Matrix-P					Weight: 24 lb	FT = 20%

LUMBER-	BRACING-
TOP CHORD 2x4 SP No.1	TOP CHORD Structural wood sheathing directly applied or 6-0-0 oc purlins, except end verticals.
BOT CHORD 2x4 SP No.1	BOT CHORD Rigid ceiling directly applied or 10-0-0 oc bracing.
WEBS 2x4 SP No.2	
OTHERS 2x6 SP No.1	

REACTIONS. (size) 2=0-3-0, 5=0-3-8
 Max Horz 2=75(LC 8)
 Max Uplift 2=190(LC 8), 5=148(LC 8)
 Max Grav 2=300(LC 1), 5=231(LC 1)

FORCES. (lb) - Max. Comp./Max. Ten. - All forces 250 (lb) or less except when shown.

- NOTES-**
- 1) Wind: ASCE 7-10; Vult=150mph Vasd=119mph; TCDL=6.0psf; BCDL=6.0psf; h=15ft; Cat. II; Exp C; Enclosed; MWFRS (envelope) and C-C Exterior(2) -0-11-0 to 3-5-13, Interior(1) 3-5-13 to 6-0-0 zone; porch left exposed;C-C for members and forces & MWFRS for reactions shown; Lumber DOL=1.60 plate grip DOL=1.60
 - 2) This truss has been designed for a 10.0 psf bottom chord live load nonconcurrent with any other live loads.
 - 3) * This truss has been designed for a live load of 20.0psf on the bottom chord in all areas with a clearance greater than 6-0-0 between the bottom chord and any other members.
 - 4) Provide mechanical connection (by others) of truss to bearing plate capable of withstanding 100 lb uplift at joint(s) except (jt=lb) 2=190, 5=148.



April 25, 2023

Job	Truss	Truss Type	Qty	Ply	Lot 2 West Pointe III	157942390
J0623-2991	M1GE	GABLE	1	1	Job Reference (optional)	

Comtech, Inc., Fayetteville, NC - 28314,

8.430 s Jan 6 2022 MiTek Industries, Inc. Mon Apr 24 12:28:00 2023 Page 1

ID:uB1kUybQLa2UVI5EAk1M8Myf?Wk-pVMjeCojyy?5?Fuls6oOyH4o0LHezTXaHfd1XJzNVIT

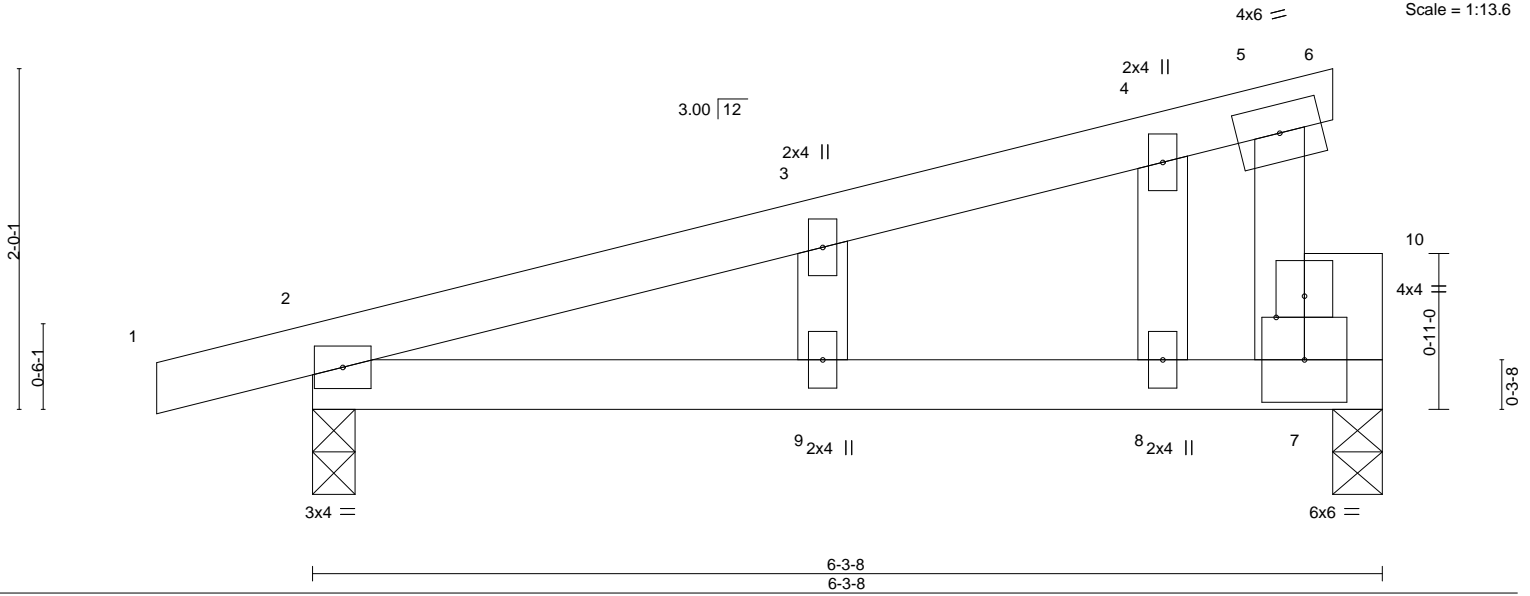

Plate Offsets (X,Y)--	[10:0-2-0,0-1-8]
-----------------------	------------------

LOADING (psf)	SPACING-	CSI.	DEFL.	in (loc)	l/defl	L/d	PLATES	GRIP
TCLL 20.0	Plate Grip DOL 1.15	TC 0.38	Vert(LL) 0.09	2-9	>812	240	MT20	244/190
TCDL 10.0	Lumber DOL 1.15	BC 0.30	Vert(CT) -0.05	9	>999	240		
BCLL 0.0 *	Rep Stress Incr YES	WB 0.02	Horz(CT) -0.00	7	n/a	n/a		
BCDL 10.0	Code IRC2015/TPI2014	Matrix-S					Weight: 26 lb	FT = 20%

LUMBER-
TOP CHORD 2x4 SP No.1
BOT CHORD 2x4 SP No.1
WEBS 2x4 SP No.2
OTHERS 2x4 SP No.2 *Except*
7-10: 2x6 SP No.1

BRACING-
TOP CHORD Structural wood sheathing directly applied or 6-0-0 oc purlins, except end verticals.
BOT CHORD Rigid ceiling directly applied or 9-9-4 oc bracing.

REACTIONS. (size) 2=0-3-0, 7=0-3-8
Max Horz 2=108(LC 8)
Max Uplift 2=-262(LC 8), 7=-207(LC 8)
Max Grav 2=300(LC 1), 7=231(LC 1)

FORCES. (lb) - Max. Comp./Max. Ten. - All forces 250 (lb) or less except when shown.
TOP CHORD 2-3=-205/251, 3-4=-164/268, 4-5=-137/260, 5-7=-163/320
BOT CHORD 2-9=-326/158, 8-9=-326/158, 7-8=-326/158

- NOTES-**
- 1) Wind: ASCE 7-10; Vult=150mph Vasd=119mph; TCDL=6.0psf; BCDL=6.0psf; h=15ft; Cat. II; Exp C; Enclosed; MWFRS (envelope) gable end zone and C-C Exterior(2) zone; porch left exposed; C-C for members and forces & MWFRS for reactions shown; Lumber DOL=1.60 plate grip DOL=1.60
 - 2) Truss designed for wind loads in the plane of the truss only. For studs exposed to wind (normal to the face), see Standard Industry Gable End Details as applicable, or consult qualified building designer as per ANSI/TPI 1.
 - 3) Gable studs spaced at 2-0-0 oc.
 - 4) This truss has been designed for a 10.0 psf bottom chord live load nonconcurrent with any other live loads.
 - 5) * This truss has been designed for a live load of 20.0psf on the bottom chord in all areas with a clearance greater than 6-0-0 between the bottom chord and any other members.
 - 6) Provide mechanical connection (by others) of truss to bearing plate capable of withstanding 100 lb uplift at joint(s) except (jt=lb) 2=262, 7=207.



April 25, 2023

WARNING - Verify design parameters and READ NOTES ON THIS AND INCLUDED MITEK REFERENCE PAGE MII-7473 rev. 1/2/2023 BEFORE USE.

Design valid for use only with MiTek® connectors. This design is based only upon parameters shown, and is for an individual building component, not a truss system. Before use, the building designer must verify the applicability of design parameters and properly incorporate this design into the overall building design. Bracing indicated is to prevent buckling of individual truss web and/or chord members only. Additional temporary and permanent bracing is always required for stability and to prevent collapse with possible personal injury and property damage. For general guidance regarding the fabrication, storage, delivery, erection and bracing of trusses and truss systems, see **ANSI/TPI1 Quality Criteria and DSB-22** available from Truss Plate Institute (www.tpinst.org) and **BCSI Building Component Safety Information** available from the Structural Building Component Association (www.sbcacomponents.com)



818 Soundside Road
Edenton, NC 27932

Job J0623-2991	Truss M2-GR	Truss Type Flat Girder	Qty 1	Ply 2	Lot 2 West Pointe III Job Reference (optional)	I57942391
-------------------	----------------	---------------------------	----------	----------	---	-----------

Comtech, Inc., Fayetteville, NC 28309

ID:uB1kUybQLa2UVI5Eak1M8Myf?Wk-18F0f_4rcr7GyW5NK4umV028peKHRWhGzOCMO7zNPZY
8.430 s Jan 6 2022 MiTek Industries, Inc. Tue Apr 25 07:30:19 2023 Page 1

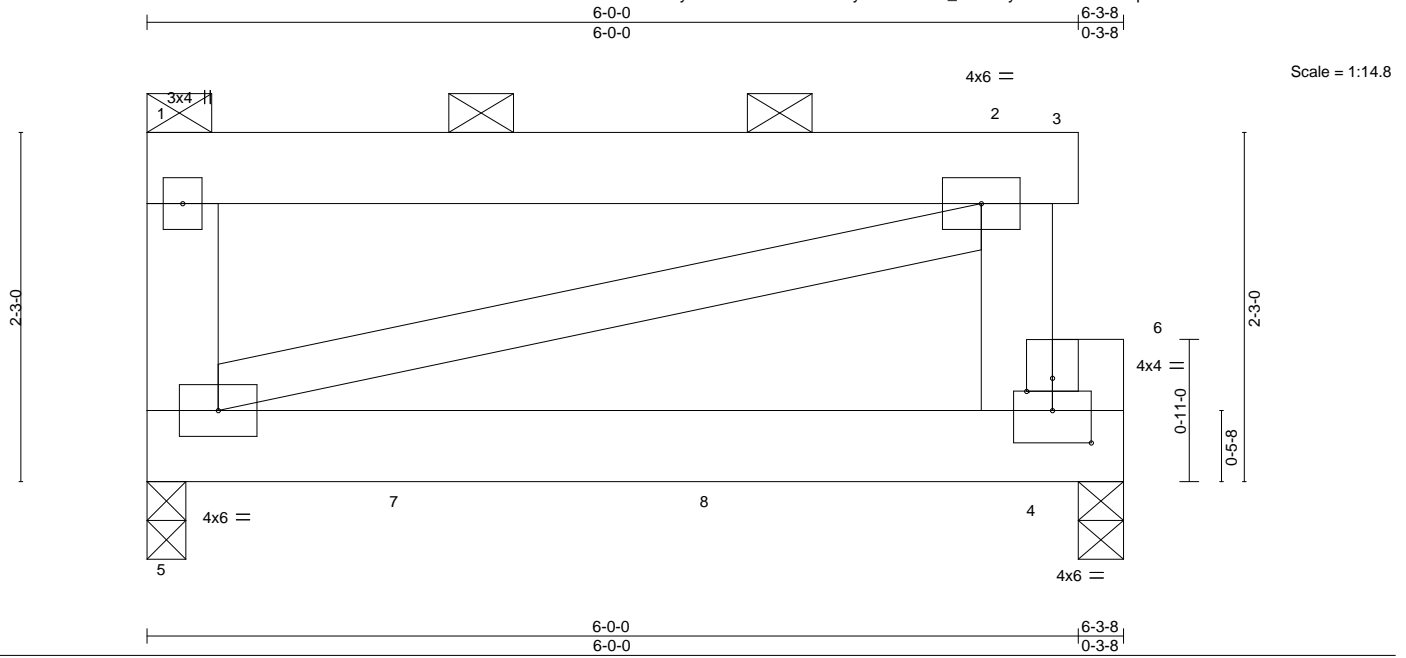

Plate Offsets (X,Y)-- [4:0-3-0,0-2-8], [6:0-2-0,0-1-0]

LOADING (psf)	SPACING-	CSI.	DEFL.	in (loc)	l/defl	L/d	PLATES	GRIP
TCLL 20.0	2-0-0	TC 0.10	Vert(LL)	-0.08	4-5	>830	MT20	244/190
TCDL 10.0	Plate Grip DOL 1.15	BC 0.72	Vert(CT)	-0.18	4-5	>375		
BCLL 0.0 *	Lumber DOL 1.15	WB 0.00	Horz(CT)	0.00	4	n/a		
BCDL 10.0	Rep Stress Incr NO	Matrix-P	Wind(LL)	0.01	4-5	>999	Weight: 87 lb	FT = 20%
	Code IRC2015/TPI2014							

LUMBER-

TOP CHORD 2x6 SP No.1
 BOT CHORD 2x6 SP 2400F 2.0E
 WEBS 2x6 SP No.1 *Except*
 2-5: 2x4 SP No.2
 OTHERS 2x6 SP No.1

BRACING-

TOP CHORD 2-0-0 oc purlins: 1-3, except end verticals.
 BOT CHORD Rigid ceiling directly applied or 10-0-0 oc bracing.

REACTIONS.

(size) 5=0-3-0, 4=0-3-8
 Max Grav 5=1738(LC 2), 4=2842(LC 2)

FORCES. (lb) - Max. Comp./Max. Ten. - All forces 250 (lb) or less except when shown.

NOTES-

- 2-ply truss to be connected together with 10d (0.131"x3") nails as follows:
 Top chords connected as follows: 2x6 - 2 rows staggered at 0-9-0 oc.
 Bottom chords connected as follows: 2x6 - 2 rows staggered at 0-7-0 oc.
 Webs connected as follows: 2x4 - 1 row at 0-9-0 oc.
- All loads are considered equally applied to all plies, except if noted as front (F) or back (B) face in the LOAD CASE(S) section. Ply to ply connections have been provided to distribute only loads noted as (F) or (B), unless otherwise indicated.
- Wind: ASCE 7-10; Vult=150mph Vasd=119mph; TCDL=6.0psf; BCDL=6.0psf; h=15ft; Cat. II; Exp C; Enclosed; MWFRS (envelope); porch left exposed; Lumber DOL=1.60 plate grip DOL=1.60
- Provide adequate drainage to prevent water ponding.
- This truss has been designed for a 10.0 psf bottom chord live load nonconcurrent with any other live loads.
- * This truss has been designed for a live load of 20.0psf on the bottom chord in all areas with a clearance greater than 6-0-0 between the bottom chord and any other members.
- This truss is designed in accordance with the 2015 International Residential Code sections R502.11.1 and R802.10.2 and referenced standard ANSI/TPI 1.
- Graphical purlin representation does not depict the size or the orientation of the purlin along the top and/or bottom chord.
- Hanger(s) or other connection device(s) shall be provided sufficient to support concentrated load(s) 1392 lb down at 1-8-12, and 1392 lb down at 3-8-12, and 1396 lb down at 5-10-0 on bottom chord. The design/selection of such connection device(s) is the responsibility of others.

LOAD CASE(S) Standard

- Dead + Roof Live (balanced): Lumber Increase=1.15, Plate Increase=1.15
 Uniform Loads (plf)
 Vert: 1-2=-60, 2-3=-60, 4-5=-20
 Concentrated Loads (lb)
 Vert: 4=-1247(F) 7=-1243(F) 8=-1243(F)

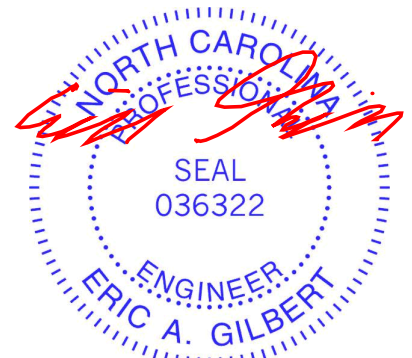

April 25, 2023

WARNING - Verify design parameters and READ NOTES ON THIS AND INCLUDED MITEK REFERENCE PAGE MII-7473 rev. 1/2/2023 BEFORE USE.

Design valid for use only with MiTek® connectors. This design is based only upon parameters shown, and is for an individual building component, not a truss system. Before use, the building designer must verify the applicability of design parameters and properly incorporate this design into the overall building design. Bracing indicated is to prevent buckling of individual truss web and/or chord members only. Additional temporary and permanent bracing is always required for stability and to prevent collapse with possible personal injury and property damage. For general guidance regarding the fabrication, storage, delivery, erection and bracing of trusses and truss systems, see **ANSI/TPI1 Quality Criteria and DSB-22** available from Truss Plate Institute (www.tpinst.org) and **BCSI Building Component Safety Information** available from the Structural Building Component Association (www.sbcacomponents.com)



818 Soundside Road
 Edenton, NC 27932

Job	Truss	Truss Type	Qty	Ply	Lot 2 West Pointe III	157942392
J0623-2991	PB	Piggyback	4	1	Job Reference (optional)	

Comtech, Inc, Fayetteville, NC - 28314,

8.430 s Jan 6 2022 MiTek Industries, Inc. Mon Apr 24 12:28:02 2023 Page 1
 ID:uB1kUyBQLa2UVI5Eak1M8Myf?Wk-luUU2tzUZfPEZ2gzXrs1iADW808RN5tkz68cCzNVIR

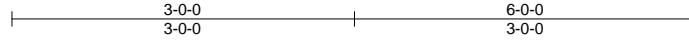

4x4 =

Scale = 1:20.2

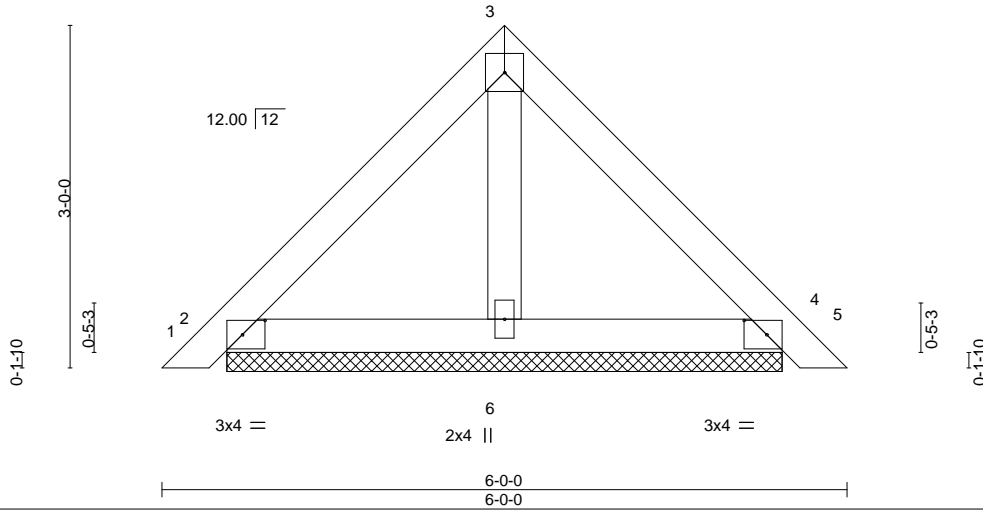

Plate Offsets (X,Y)-- [2:0-2-6,0-1-8], [4:0-2-6,0-1-8]

LOADING (psf)	SPACING-	CSL.	DEFL.	in (loc)	l/defl	L/d	PLATES	GRIP
TCLL 20.0	Plate Grip DOL 1.15	TC 0.13	Vert(LL) 0.00	5	n/r	120	MT20	244/190
TCDL 10.0	Lumber DOL 1.15	BC 0.04	Vert(CT) 0.00	5	n/r	120		
BCLL 0.0 *	Rep Stress Incr YES	WB 0.01	Horz(CT) 0.00	4	n/a	n/a		
BCDL 10.0	Code IRC2015/TPI2014	Matrix-P					Weight: 23 lb	FT = 20%

LUMBER-
 TOP CHORD 2x4 SP No.1
 BOT CHORD 2x4 SP No.1
 OTHERS 2x4 SP No.2

BRACING-
 TOP CHORD Structural wood sheathing directly applied or 6-0-0 oc purlins.
 BOT CHORD Rigid ceiling directly applied or 10-0-0 oc bracing.

REACTIONS. (size) 2=4-10-6, 4=4-10-6, 6=4-10-6
 Max Horz 2=111(LC 11)
 Max Uplift 2=-75(LC 13), 4=-84(LC 13), 6=-6(LC 12)
 Max Grav 2=142(LC 1), 4=142(LC 1), 6=151(LC 3)

FORCES. (lb) - Max. Comp./Max. Ten. - All forces 250 (lb) or less except when shown.

NOTES-

- Unbalanced roof live loads have been considered for this design.
- Wind: ASCE 7-10; Vult=150mph Vasd=119mph; TCDL=6.0psf; BCDL=6.0psf; h=15ft; Cat. II; Exp C; Enclosed; MWFRS (envelope) gable end zone and C-C Exterior(2) zone;C-C for members and forces & MWFRS for reactions shown; Lumber DOL=1.60 plate grip DOL=1.60
- Gable requires continuous bottom chord bearing.
- This truss has been designed for a 10.0 psf bottom chord live load nonconcurrent with any other live loads.
- * This truss has been designed for a live load of 20.0psf on the bottom chord in all areas with a clearance greater than 6-0-0 between the bottom chord and any other members.
- Provide mechanical connection (by others) of truss to bearing plate capable of withstanding 100 lb uplift at joint(s) 2, 4, 6.
- See Standard Industry Piggyback Truss Connection Detail for Connection to base truss as applicable, or consult qualified building designer.

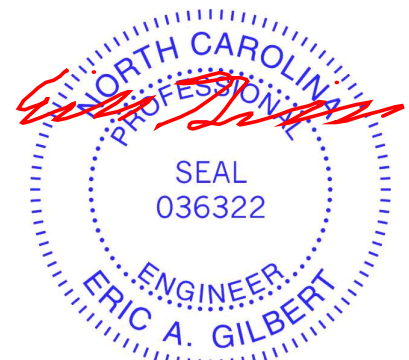

April 25, 2023

WARNING - Verify design parameters and READ NOTES ON THIS AND INCLUDED MITEK REFERENCE PAGE MII-7473 rev. 1/2/2023 BEFORE USE.
 Design valid for use only with MiTek® connectors. This design is based only upon parameters shown, and is for an individual building component, not a truss system. Before use, the building designer must verify the applicability of design parameters and properly incorporate this design into the overall building design. Bracing indicated is to prevent buckling of individual truss web and/or chord members only. Additional temporary and permanent bracing is always required for stability and to prevent collapse with possible personal injury and property damage. For general guidance regarding the fabrication, storage, delivery, erection and bracing of trusses and truss systems, see **ANSI/TPH Quality Criteria and DSB-22** available from Truss Plate Institute (www.tpinst.org) and **BCSI Building Component Safety Information** available from the Structural Building Component Association (www.sbcacomponents.com)



Job	Truss	Truss Type	Qty	Ply	Lot 2 West Pointe III	157942393
J0623-2991	VB1	VALLEY	1	1	Job Reference (optional)	

Comtech, Inc, Fayetteville, NC - 28314,

8.430 s Jan 6 2022 MiTek Industries, Inc. Mon Apr 24 12:28:03 2023 Page 1
 ID:uB1kUybQLa2UVI5Eak1M8Myf?Wk-D42sGDrbFtNfsjdtXEM5ZviLmYLWAQ00zcsh8ezNVIQ

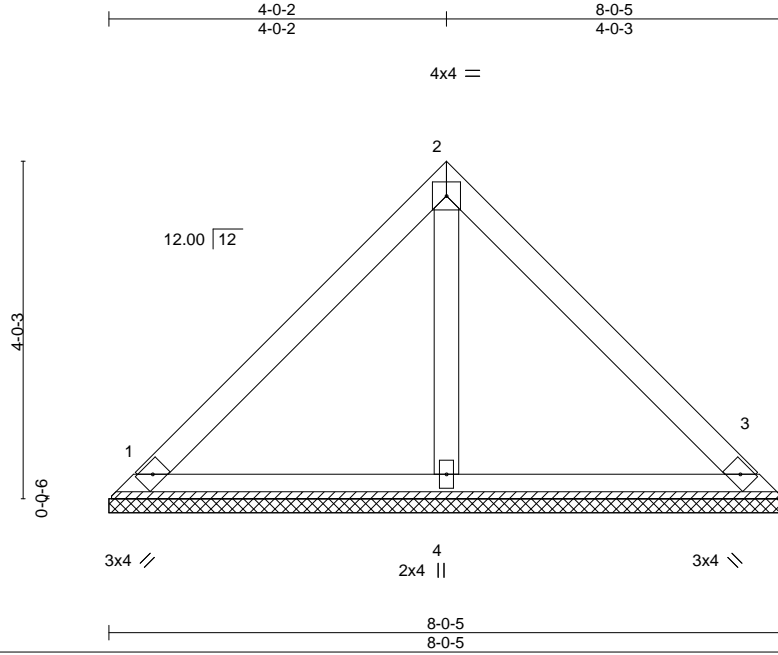

Scale = 1:27.4

LOADING (psf)	SPACING-	CSI.	DEFL.	in	(loc)	l/defl	L/d	PLATES	GRIP
TCLL 20.0	Plate Grip DOL 1.15	TC 0.29	Vert(LL) n/a	-	n/a	999		MT20	244/190
TCDL 10.0	Lumber DOL 1.15	BC 0.10	Vert(CT) n/a	-	n/a	999			
BCLL 0.0 *	Rep Stress Incr YES	WB 0.03	Horz(CT) 0.00	3	n/a	n/a			
BCDL 10.0	Code IRC2015/TPI2014	Matrix-P						Weight: 32 lb	FT = 20%

LUMBER-

TOP CHORD 2x4 SP No.1
 BOT CHORD 2x4 SP No.1
 OTHERS 2x4 SP No.2

BRACING-

TOP CHORD Structural wood sheathing directly applied or 6-0-0 oc purlins.
 BOT CHORD Rigid ceiling directly applied or 10-0-0 oc bracing.

REACTIONS.

(size) 1=8-0-5, 3=8-0-5, 4=8-0-5
 Max Horz 1=117(LC 9)
 Max Uplift 1=-58(LC 13), 3=-58(LC 13)
 Max Grav 1=178(LC 1), 3=178(LC 1), 4=229(LC 1)

FORCES. (lb) - Max. Comp./Max. Ten. - All forces 250 (lb) or less except when shown.

NOTES-

- Unbalanced roof live loads have been considered for this design.
- Wind: ASCE 7-10; Vult=150mph Vasd=119mph; TCDL=6.0psf; BCDL=6.0psf; h=15ft; Cat. II; Exp C; Enclosed; MWFRS (envelope) and C-C Exterior(2) zone;C-C for members and forces & MWFRS for reactions shown; Lumber DOL=1.60 plate grip DOL=1.60
- Gable requires continuous bottom chord bearing.
- This truss has been designed for a 10.0 psf bottom chord live load nonconcurrent with any other live loads.
- * This truss has been designed for a live load of 20.0psf on the bottom chord in all areas with a clearance greater than 6-0-0 between the bottom chord and any other members.
- Provide mechanical connection (by others) of truss to bearing plate capable of withstanding 100 lb uplift at joint(s) 1, 3.



April 25, 2023

WARNING - Verify design parameters and READ NOTES ON THIS AND INCLUDED MITEK REFERENCE PAGE MII-7473 rev. 1/2/2023 BEFORE USE.

Design valid for use only with MiTek® connectors. This design is based only upon parameters shown, and is for an individual building component, not a truss system. Before use, the building designer must verify the applicability of design parameters and properly incorporate this design into the overall building design. Bracing indicated is to prevent buckling of individual truss web and/or chord members only. Additional temporary and permanent bracing is always required for stability and to prevent collapse with possible personal injury and property damage. For general guidance regarding the fabrication, storage, delivery, erection and bracing of trusses and truss systems, see **ANSI/TPH Quality Criteria and DSB-22** available from Truss Plate Institute (www.tpinst.org) and **BCSI Building Component Safety Information** available from the Structural Building Component Association (www.sbcacomponents.com)



818 Soundside Road
 Edenton, NC 27932

Job	Truss	Truss Type	Qty	Ply	Lot 2 West Pointe III	157942394
J0623-2991	VB2	VALLEY	1	1	Job Reference (optional)	

Comtech, Inc. Fayetteville, NC - 28314,

8.430 s Jan 6 2022 MiTek Industries, Inc. Mon Apr 24 12:28:05 2023 Page 1

ID:uB1kUybQLa2UVI5EAk1M8Myf?Wk-9T9chvssmUdN51nFffOZfKok_M2vekqJQwLoCWzNVIO

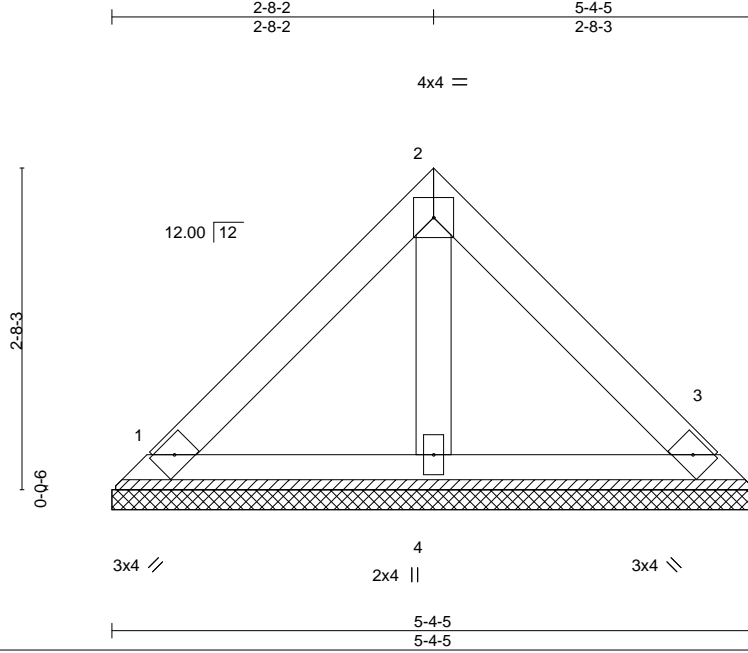

Scale = 1:19.2

LOADING (psf)	SPACING-	2-0-0	CSI.	DEFL.	in	(loc)	l/defl	L/d	PLATES	GRIP
TCLL 20.0	Plate Grip DOL	1.15	TC 0.11	Vert(LL)	n/a	-	n/a	999	MT20	244/190
TCDL 10.0	Lumber DOL	1.15	BC 0.04	Vert(CT)	n/a	-	n/a	999		
BCLL 0.0 *	Rep Stress Incr	YES	WB 0.01	Horz(CT)	0.00	3	n/a	n/a		
BCDL 10.0	Code IRC2015/TPI2014		Matrix-P						Weight: 21 lb	FT = 20%

LUMBER-

TOP CHORD 2x4 SP No.1
 BOT CHORD 2x4 SP No.1
 OTHERS 2x4 SP No.2

BRACING-

TOP CHORD Structural wood sheathing directly applied or 5-4-5 oc purlins.
 BOT CHORD Rigid ceiling directly applied or 10-0-0 oc bracing.

REACTIONS.

(size) 1=5-4-5, 3=5-4-5, 4=5-4-5
 Max Horz 1=74(LC 9)
 Max Uplift 1=-37(LC 13), 3=-37(LC 13)
 Max Grav 1=113(LC 1), 3=113(LC 1), 4=146(LC 1)

FORCES. (lb) - Max. Comp./Max. Ten. - All forces 250 (lb) or less except when shown.

NOTES-

- Unbalanced roof live loads have been considered for this design.
- Wind: ASCE 7-10; Vult=150mph Vasd=119mph; TCDL=6.0psf; BCDL=6.0psf; h=15ft; Cat. II; Exp C; Enclosed; MWFRS (envelope) and C-C Exterior(2) zone;C-C for members and forces & MWFRS for reactions shown; Lumber DOL=1.60 plate grip DOL=1.60
- Gable requires continuous bottom chord bearing.
- This truss has been designed for a 10.0 psf bottom chord live load nonconcurrent with any other live loads.
- * This truss has been designed for a live load of 20.0psf on the bottom chord in all areas with a clearance greater than 6-0-0 between the bottom chord and any other members.
- Provide mechanical connection (by others) of truss to bearing plate capable of withstanding 100 lb uplift at joint(s) 1, 3.

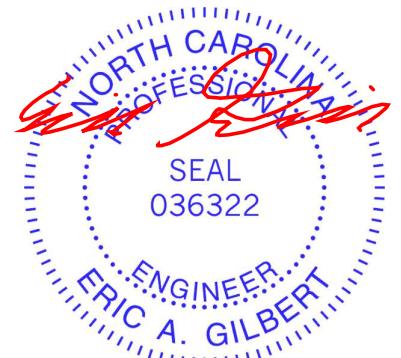

April 25, 2023

WARNING - Verify design parameters and READ NOTES ON THIS AND INCLUDED MITEK REFERENCE PAGE MII-7473 rev. 1/2/2023 BEFORE USE.

Design valid for use only with MiTek® connectors. This design is based only upon parameters shown, and is for an individual building component, not a truss system. Before use, the building designer must verify the applicability of design parameters and properly incorporate this design into the overall building design. Bracing indicated is to prevent buckling of individual truss web and/or chord members only. Additional temporary and permanent bracing is always required for stability and to prevent collapse with possible personal injury and property damage. For general guidance regarding the fabrication, storage, delivery, erection and bracing of trusses and truss systems, see **ANSI/TPH Quality Criteria and DSB-22** available from Truss Plate Institute (www.tpinst.org) and **BCSI Building Component Safety Information** available from the Structural Building Component Association (www.sbcacomponents.com)



818 Soundside Road
 Edenton, NC 27932

Job	Truss	Truss Type	Qty	Ply	Lot 2 West Pointe III	157942395
J0623-2991	VB3	VALLEY	1	1	Job Reference (optional)	

Comtech, Inc, Fayetteville, NC - 28314,

8.430 s Jan 6 2022 MiTek Industries, Inc. Mon Apr 24 12:28:06 2023 Page 1
 ID:uB1kUybQLa2UVI5EAk1M8Myf?Wk-efj?uFtUXolEjAMSCMvoBYKwCiofNBCTfa4LlzzNVIN

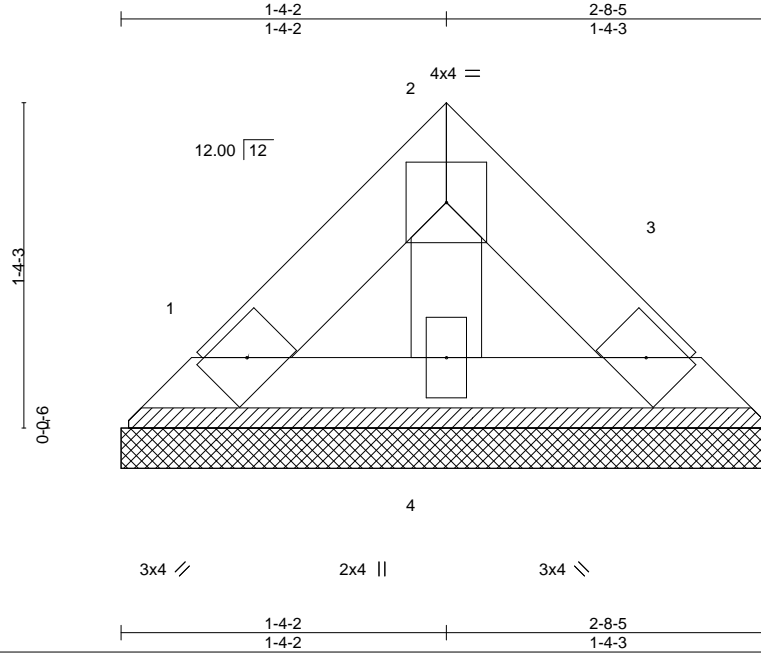

Scale = 1:9.5

LOADING (psf)	SPACING-	CSI.	DEFL.	in	(loc)	l/defl	L/d	PLATES	GRIP
TCLL 20.0	2-0-0	TC 0.02	Vert(LL)	n/a	-	n/a	999	MT20	244/190
TCDL 10.0	1.15	BC 0.01	Vert(CT)	n/a	-	n/a	999		
BCLL 0.0 *	1.15	WB 0.00	Horz(CT)	0.00	3	n/a	n/a		
BCDL 10.0	YES	Matrix-P						Weight: 9 lb	FT = 20%
	Code IRC2015/TPI2014								

LUMBER-

TOP CHORD 2x4 SP No.1
 BOT CHORD 2x4 SP No.1
 WEBS 2x4 SP No.2

BRACING-

TOP CHORD Structural wood sheathing directly applied or 2-8-5 oc purlins.
 BOT CHORD Rigid ceiling directly applied or 10-0-0 oc bracing.

REACTIONS.

(size) 1=2-8-5, 3=2-8-5, 4=2-8-5
 Max Horz 1=-32(LC 8)
 Max Uplift 1=-16(LC 13), 3=-16(LC 13)
 Max Grav 1=48(LC 1), 3=48(LC 1), 4=62(LC 1)

FORCES. (lb) - Max. Comp./Max. Ten. - All forces 250 (lb) or less except when shown.

NOTES-

- Unbalanced roof live loads have been considered for this design.
- Wind: ASCE 7-10; Vult=150mph Vasd=119mph; TCDL=6.0psf; BCDL=6.0psf; h=15ft; Cat. II; Exp C; Enclosed; MWFRS (envelope) and C-C Exterior(2) zone;C-C for members and forces & MWFRS for reactions shown; Lumber DOL=1.60 plate grip DOL=1.60
- Gable requires continuous bottom chord bearing.
- This truss has been designed for a 10.0 psf bottom chord live load nonconcurrent with any other live loads.
- * This truss has been designed for a live load of 20.0psf on the bottom chord in all areas with a clearance greater than 6-0-0 between the bottom chord and any other members.
- Provide mechanical connection (by others) of truss to bearing plate capable of withstanding 100 lb uplift at joint(s) 1, 3.



April 25, 2023

WARNING - Verify design parameters and READ NOTES ON THIS AND INCLUDED MITEK REFERENCE PAGE MII-7473 rev. 1/2/2023 BEFORE USE.

Design valid for use only with MiTek® connectors. This design is based only upon parameters shown, and is for an individual building component, not a truss system. Before use, the building designer must verify the applicability of design parameters and properly incorporate this design into the overall building design. Bracing indicated is to prevent buckling of individual truss web and/or chord members only. Additional temporary and permanent bracing is always required for stability and to prevent collapse with possible personal injury and property damage. For general guidance regarding the fabrication, storage, delivery, erection and bracing of trusses and truss systems, see **ANSI/TPH Quality Criteria and DSB-22** available from Truss Plate Institute (www.tpinst.org) and **BCSI Building Component Safety Information** available from the Structural Building Component Association (www.sbcacomponents.com)



818 Soundside Road
 Edenton, NC 27932

Job J0623-2991	Truss VD1	Truss Type VALLEY	Qty 1	Ply 1	Lot 2 West Pointe III Job Reference (optional)	157942396
-------------------	--------------	----------------------	----------	----------	---	-----------

Comtech, Inc., Fayetteville, NC - 28314,

8.430 s Jan 6 2022 MiTek Industries, Inc. Mon Apr 24 12:28:07 2023 Page 1
ID:uB1kUybQLa2UVI5EAK1M8Myf?Wk-6sHN6bu6I5t5LKxem4Q1klt3D9jcciecuEqvHPzNVIM

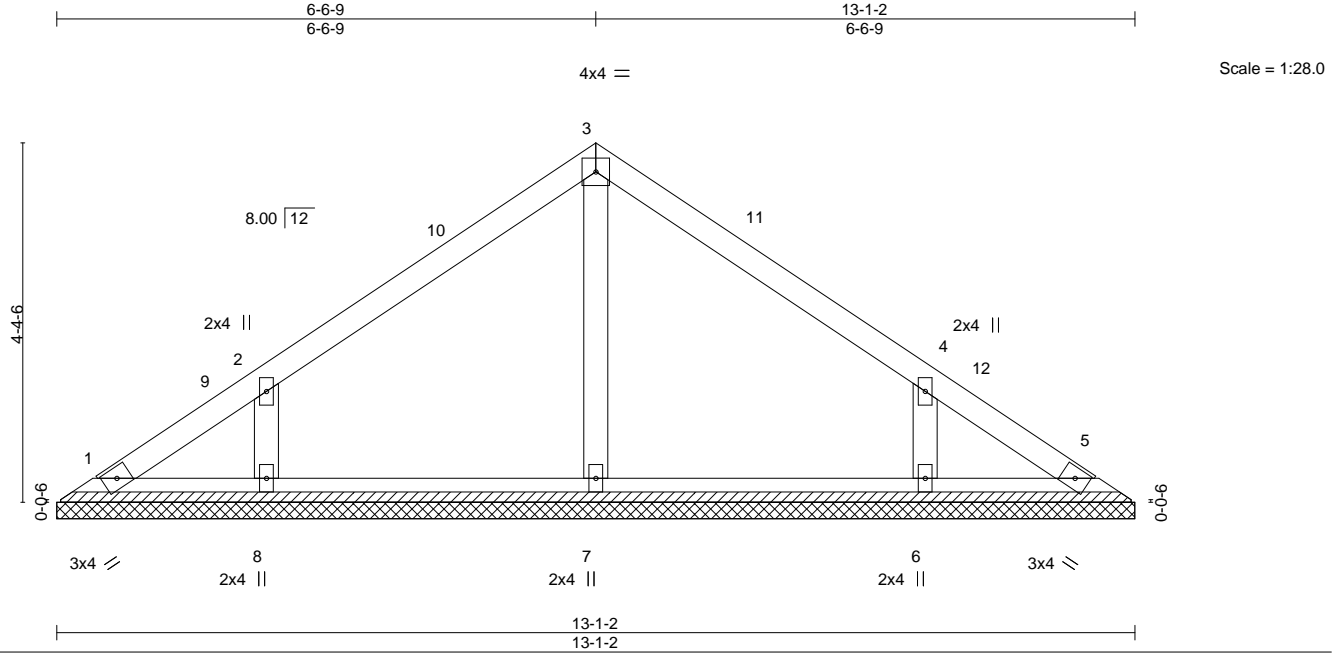

Plate Offsets (X,Y)-- [4:0-0-0,0-0-0]

LOADING (psf)	SPACING-	2-0-0	CSI.	DEFL.	in (loc)	l/defl	L/d	PLATES	GRIP
TCLL 20.0	Plate Grip DOL	1.15	TC 0.13	Vert(LL)	n/a	-	n/a	MT20	244/190
TCDL 10.0	Lumber DOL	1.15	BC 0.09	Vert(CT)	n/a	-	n/a		
BCLL 0.0 *	Rep Stress Incr	YES	WB 0.05	Horz(CT)	0.00	5	n/a		
BCDL 10.0	Code	IRC2015/TPI2014	Matrix-S					Weight: 50 lb	FT = 20%

LUMBER-	BRACING-
TOP CHORD 2x4 SP No.1	TOP CHORD Structural wood sheathing directly applied or 6-0-0 oc purlins.
BOT CHORD 2x4 SP No.1	BOT CHORD Rigid ceiling directly applied or 10-0-0 oc bracing.
OTHERS 2x4 SP No.2	

REACTIONS. All bearings 13-1-2.
 (lb) - Max Horz 1=129(LC 9)
 Max Uplift All uplift 100 lb or less at joint(s) 1, 5 except 8=153(LC 12), 6=153(LC 13)
 Max Grav All reactions 250 lb or less at joint(s) 1, 5 except 7=264(LC 1), 8=340(LC 19), 6=340(LC 20)

FORCES. (lb) - Max. Comp./Max. Ten. - All forces 250 (lb) or less except when shown.
 WEBS 2-8=346/278, 4-6=346/278

- NOTES-**
- Unbalanced roof live loads have been considered for this design.
 - Wind: ASCE 7-10; Vult=150mph Vasd=119mph; TCDL=6.0psf; BCDL=6.0psf; h=15ft; Cat. II; Exp C; Enclosed; MWFRS (envelope) and C-C Exterior(2) 0-5-15 to 4-10-12, Interior(1) 4-10-12 to 6-6-9, Exterior(2) 6-6-9 to 10-11-6, Interior(1) 10-11-6 to 12-7-3 zone;C-C for members and forces & MWFRS for reactions shown; Lumber DOL=1.60 plate grip DOL=1.60
 - Gable requires continuous bottom chord bearing.
 - This truss has been designed for a 10.0 psf bottom chord live load nonconcurrent with any other live loads.
 - * This truss has been designed for a live load of 20.0psf on the bottom chord in all areas with a clearance greater than 6-0-0 between the bottom chord and any other members.
 - Provide mechanical connection (by others) of truss to bearing plate capable of withstanding 100 lb uplift at joint(s) 1, 5 except (jt=lb) 8=153, 6=153.



April 25, 2023

Job	Truss	Truss Type	Qty	Ply	Lot 2 West Pointe III	I57942397
J0623-2991	VD2	VALLEY	1	1		

Comtech, Inc., Fayetteville, NC - 28314,

8.430 s Jan 6 2022 MiTek Industries, Inc. Mon Apr 24 12:28:08 2023 Page 1
 ID:uB1kUybQLa2UVI5EAk1M8Myf?Wk-a2rJxvk3P?yyUVqKnyGGzPEJZ29r5Tm6uZSprzNVIL

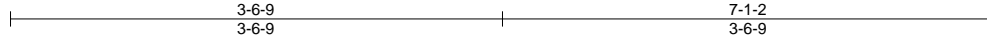

4x4 =

Scale = 1:16.6

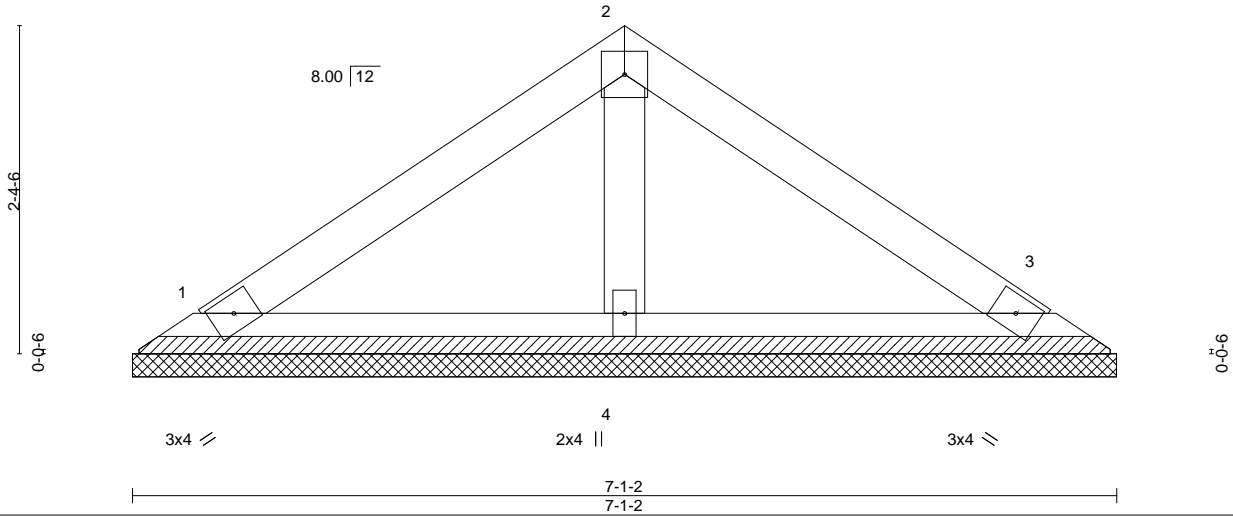

LOADING (psf)	SPACING-	2-0-0	CSI.	DEFL.	in	(loc)	l/defl	L/d	PLATES	GRIP
TCLL 20.0	Plate Grip DOL	1.15	TC 0.15	Vert(LL)	n/a	-	n/a	999	MT20	244/190
TCDL 10.0	Lumber DOL	1.15	BC 0.07	Vert(CT)	n/a	-	n/a	999		
BCLL 0.0 *	Rep Stress Incr	YES	WB 0.02	Horz(CT)	0.00	3	n/a	n/a		
BCDL 10.0	Code IRC2015/TPI2014		Matrix-P						Weight: 24 lb	FT = 20%

LUMBER-

TOP CHORD 2x4 SP No.1
 BOT CHORD 2x4 SP No.1
 OTHERS 2x4 SP No.2

BRACING-

TOP CHORD Structural wood sheathing directly applied or 6-0-0 oc purlins.
 BOT CHORD Rigid ceiling directly applied or 10-0-0 oc bracing.

REACTIONS.

(size) 1=7-1-2, 3=7-1-2, 4=7-1-2
 Max Horz 1=65(LC 8)
 Max Uplift 1=40(LC 12), 3=46(LC 13), 4=4(LC 12)
 Max Grav 1=133(LC 1), 3=135(LC 20), 4=223(LC 1)

FORCES. (lb) - Max. Comp./Max. Ten. - All forces 250 (lb) or less except when shown.

NOTES-

- Unbalanced roof live loads have been considered for this design.
- Wind: ASCE 7-10; Vult=150mph Vasd=119mph; TCDL=6.0psf; BCDL=6.0psf; h=15ft; Cat. II; Exp C; Enclosed; MWFRS (envelope) and C-C Exterior(2) zone;C-C for members and forces & MWFRS for reactions shown; Lumber DOL=1.60 plate grip DOL=1.60
- Gable requires continuous bottom chord bearing.
- This truss has been designed for a 10.0 psf bottom chord live load nonconcurrent with any other live loads.
- * This truss has been designed for a live load of 20.0psf on the bottom chord in all areas with a clearance greater than 6-0-0 between the bottom chord and any other members.
- Provide mechanical connection (by others) of truss to bearing plate capable of withstanding 100 lb uplift at joint(s) 1, 3, 4.



April 25, 2023

WARNING - Verify design parameters and READ NOTES ON THIS AND INCLUDED MITEK REFERENCE PAGE MII-7473 rev. 1/2/2023 BEFORE USE.

Design valid for use only with MiTek® connectors. This design is based only upon parameters shown, and is for an individual building component, not a truss system. Before use, the building designer must verify the applicability of design parameters and properly incorporate this design into the overall building design. Bracing indicated is to prevent buckling of individual truss web and/or chord members only. Additional temporary and permanent bracing is always required for stability and to prevent collapse with possible personal injury and property damage. For general guidance regarding the fabrication, storage, delivery, erection and bracing of trusses and truss systems, see **ANSI/TPH Quality Criteria and DSB-22** available from Truss Plate Institute (www.tpinst.org) and **BCSI Building Component Safety Information** available from the Structural Building Component Association (www.sbcacomponents.com)



818 Soundside Road
 Edenton, NC 27932

Symbols

PLATE LOCATION AND ORIENTATION



Center plate on joint unless x, y offsets are indicated. Dimensions are in ft-in-sixteenths. Apply plates to both sides of truss and fully embed teeth.



For 4 x 2 orientation, locate plates 0- 1/16" from outside edge of truss.

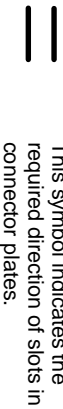

This symbol indicates the required direction of slots in connector plates.

* Plate location details available in MITek software or upon request.

PLATE SIZE

4 X 4

The first dimension is the plate width measured perpendicular to slots. Second dimension is the length parallel to slots.

LATERAL BRACING LOCATION



Indicated by symbol shown and/or by text in the bracing section of the output. Use T or I bracing if indicated.

BEARING

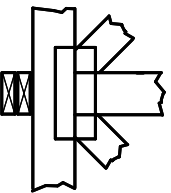

Indicates location where bearings (supports) occur. Icons vary but reaction section indicates joint number/letter where bearings occur. Min size shown is for crushing only.

Industry Standards:

ANSI/TP1: National Design Specification for Metal Plate Connected Wood Truss Construction.
DSB-22: Design Standard for Bracing.
BCSI: Building Component Safety Information, Guide to Good Practice for Handling, Installing, Restraining & Bracing of Metal Plate Connected Wood Trusses.

Numbering System



1 TOP CHORDS
2 Joint ID
3 typ.

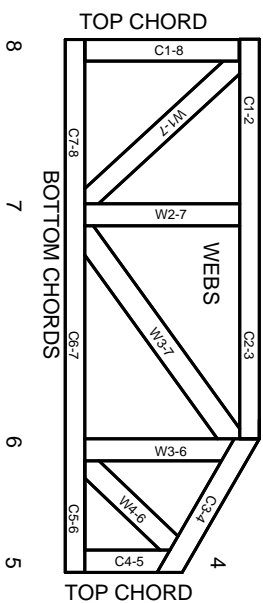

JOINTS ARE GENERALLY NUMBERED/LETTERED CLOCKWISE AROUND THE TRUSS STARTING AT THE JOINT FARTHEST TO THE LEFT.

CHORDS AND WEBS ARE IDENTIFIED BY END JOINT NUMBERS/LETTERS.

Product Code Approvals

ICC-ES Reports:

ESR-1988, ESR-2362, ESR-2685, ESR-3282
ESR-4722, ESL-1388

Design General Notes

Trusses are designed for wind loads in the plane of the truss unless otherwise shown.

Lumber design values are in accordance with ANSI/TP1 section 6.3. These truss designs rely on Lumber values established by others.

© 2023 MITek® All Rights Reserved

General Safety Notes

Failure to Follow Could Cause Property Damage or Personal Injury

1. Additional stability/bracing for truss system, e.g. diagonal or X-bracing, is always required. See BCSI.
2. Truss bracing must be designed by an engineer. For wide truss spacing, individual lateral braces themselves may require bracing, or alternative Tor I bracing should be considered.
3. Never exceed the design loading shown and never stack materials on inadequately braced trusses.
4. Provide copies of this truss design to the building designer, erection supervisor, property owner and all other interested parties.
5. Cut members to bear tightly against each other.
6. Place plates on each face of truss at each joint and embed fully. Knots and wane at joint locations are regulated by ANSI/TP1 1.
7. Design assumes trusses will be suitably protected from the environment in accord with ANSI/TP1 1.
8. Unless otherwise noted, moisture content of lumber shall not exceed 19% at time of fabrication.
9. Unless expressly noted, this design is not applicable for use with fire retardant, preservative treated, or green lumber.
10. Camber is a non-structural consideration and is the responsibility of truss fabricator. General practice is to camber for dead load deflection.
11. Plate type, size, orientation and location dimensions indicated are minimum plating requirements.
12. Lumber used shall be of the species and size, and in all respects, equal to or better than that specified.
13. Top chords must be sheathed or purlins provided at spacing indicated on design.
14. Bottom chords require lateral bracing at 10 ft. spacing, or less, if no ceiling is installed, unless otherwise noted.
15. Connections not shown are the responsibility of others.
16. Do not cut or alter truss member or plate without prior approval of an engineer.
17. Install and load vertically unless indicated otherwise.
18. Use of green or treated lumber may pose unacceptable environmental, health or performance risks. Consult with project engineer before use.
19. Review all portions of this design (front, back, words and pictures) before use. Reviewing pictures alone is not sufficient.
20. Design assumes manufacture in accordance with ANSI/TP1 1 Quality Criteria.
21. The design does not take into account any dynamic or other loads other than those expressly stated.

MITek

ENGINEERING BY
TRENGO
A MITek Affiliate

MITek Engineering Reference Sheet: MIL-7473 rev. 1/2/2023



ROOF & FLOOR TRUSSES & BEAMS

Reilly Road Industrial Park
Fayetteville, N.C. 28309
Phone: (910) 864-8787
Fax: (910) 864-4444

Bearing reactions less than or equal to 3000# are deemed to comply with the prescriptive Code requirements. The contractor shall refer to the attached Tables (derived from the prescriptive Code requirements) to determine the minimum foundation size and number of wood studs required to support reactions greater than 3000# but not greater than 15000#. A registered design professional shall be retained to design the support system for any reaction that exceeds those specified in the attached Tables. A registered design professional shall be retained to design the support system for all reactions that exceed 15000#.

Signature Jonathan Landry
Jonathan Landry

LOAD CHART FOR JACK STUDS

(BASED ON TABLES R502.5(1) & (b))
NUMBER OF JACK STUDS REQUIRED @ EA END OF HEADER/GIRDER

END REACTION (UP TO)	REQ'D STUDS FOR (1) 1/2" HEADER	END REACTION (UP TO)	REQ'D STUDS FOR (1) 1/2" HEADER	END REACTION (UP TO)	REQ'D STUDS FOR (1) 1/2" HEADER
1700	1	2550	1	3400	1
3400	2	5100	2	5100	2
5100	3	7650	3	6800	2
6800	4	10200	4	10200	3
8500	5	12750	5	13600	4
10200	6	15300	6	17000	5
11900	7				
13600	8				
15300	9				

All Truss Reactions are Less than 3,000 lbs. Unless Noted Otherwise.
○ -- Denotes Reaction Greater than 3,000 lbs. Reaction / # of Studs

All Walls Shown Are Considered Load Bearing

Plumbing Drop Notes

1. Plumbing drop locations shown are NOT exact.
2. Contractor to verify ALL plumbing drop locations prior to setting Floor Trusses.
3. Adjust spacing as needed not to exceed 24"oc.

Dimension Notes

1. All exterior wall to wall dimensions are to face of sheathing unless noted otherwise
2. All interior wall dimensions are to face of stud unless noted otherwise
3. All exterior wall to truss dimensions are to face of stud unless noted otherwise

Hatch Legend

- Second Floor Walls
- Box Storage
- Drop Beam
- Flush Beam

Connector Information					Nail Information	
Sym	Product	Manuf	Qty	Supported Member	Header	Truss
●	HUS410	USP	15	NA	16d/3-1/2"	16d/3-1/2"
○	MSH422	USP	2	Varies	10d/3"	10d/3"

Products					
PlotID	Length	Product	Plies	Net Qty	Fab Type
BM1	4' 0"	2x10 SPF No.1	2	4	FF
BM2	9' 0"	1-3/4"x 14" LVL Kerto-S	2	2	FF
BM3	11' 0"	1-3/4"x 14" LVL Kerto-S	2	2	FF
GDH	21' 0"	1-3/4"x 16" LVL Kerto-S	2	2	FF
GDH2	13' 0"	1-3/4"x 11-7/8" LVL Kerto-S	2	2	FF

1 Truss Placement Plan
Scale: 1/4"=1'

▲ = Denotes Left End of Truss
(Reference Engineered Truss Drawing)

BUILDER	WEAVER DEVELOPMENT	CITY / CO.	SANFORD / HARNETT
JOB NAME	Lot 2 West Pointe III	ADDRESS	53 Hillwood Court
PLAN	Nicholson / 3GRF, CP	MODEL	Floor
SEAL DATE	N/A	DATE REV.	09/21/23
QUOTE #		DRAWN BY	Jonathan Landry
JOB #	J0623-2993	SALES REP.	Lenny Norris

THIS IS A TRUSS PLACEMENT DIAGRAM ONLY. These trusses are designed as individual building components to be incorporated into the building design at the specification of the building designer. See individual design sheets for each truss design identified on the placement drawing. The building designer is responsible for temporary and permanent bracing of the roof and floor system and for the overall structure. The design of the truss support structure including headers, beams, walls, and columns is the responsibility of the building designer. For general guidance regarding bracing, consult BCSI-B1 and BCSI-B3 provided with the truss delivery package or online @ sbciindustry.com

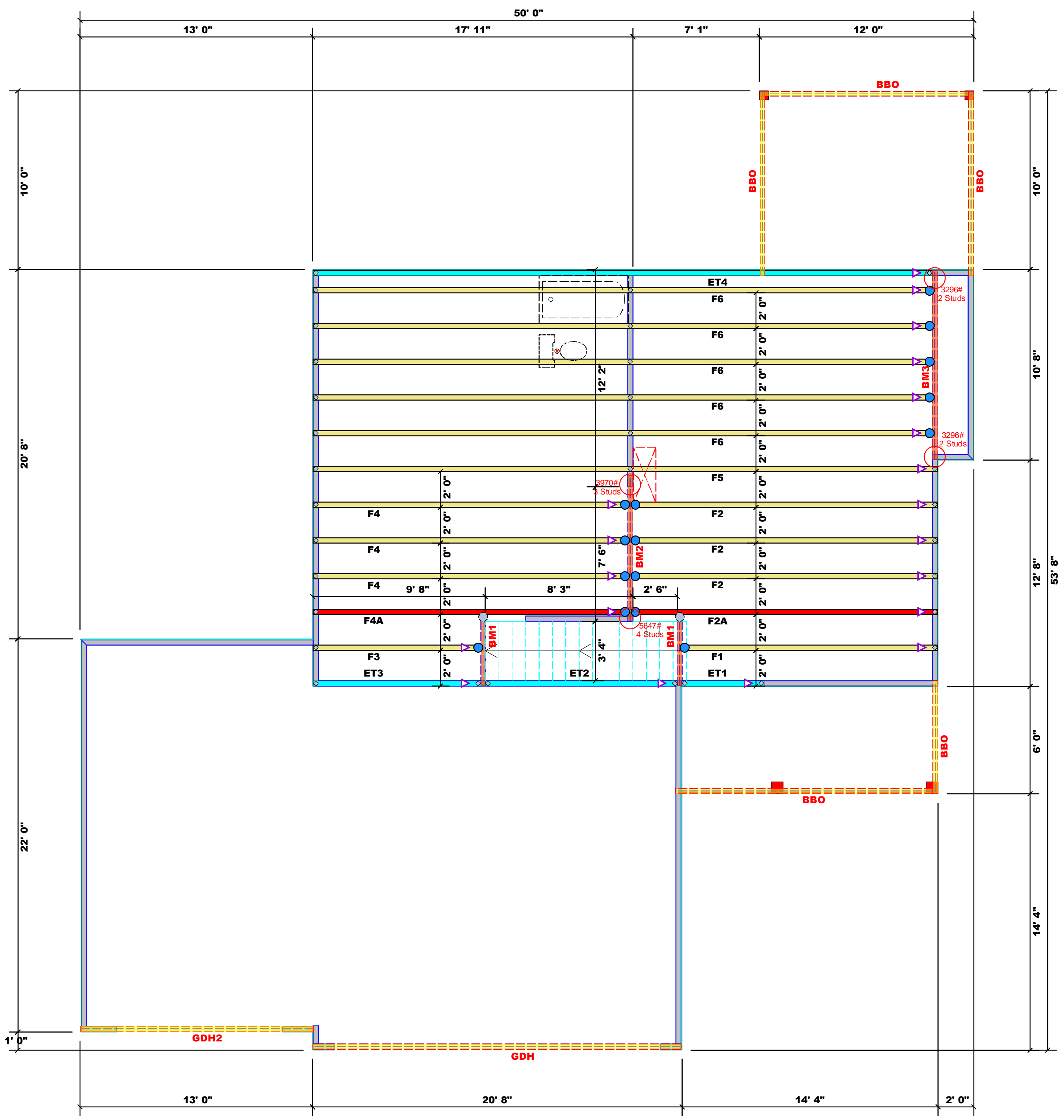

Bearing reactions less than or equal to 3000# are deemed to comply with the prescriptive Code requirements. The contractor shall refer to the attached Tables (derived from the prescriptive Code requirements) to determine the minimum foundation size and number of wood studs required to support reactions greater than 3000# but not greater than 15000#. A registered design professional shall be retained to design the support system for any reaction that exceeds those specified in the attached Tables. A registered design professional shall be retained to design the support system for all reactions that exceed 15000#.

Signature Jonathan Landry
Jonathan Landry

LOAD CHART FOR JACK STUDS

(BASED ON TABLES R502.5(1) & (b))

NUMBER OF JACK STUDS REQUIRED @ EA END OF HEADER/GIRDER

END REACTION (UP TO)	REQ'D STUDS FOR (1) 1/4" HEADER	END REACTION (UP TO)	REQ'D STUDS FOR (1) 1/4" HEADER	END REACTION (UP TO)	REQ'D STUDS FOR (1) 1/4" HEADER
1700	1	2550	1	3400	1
3400	2	5100	2	6800	2
5100	3	7650	3	10200	3
6800	4	10200	4	13600	4
8500	5	12750	5	17000	5
10200	6	15300	6		
11900	7				
13600	8				
15300	9				

All Truss Reactions are Less than 3,000 lbs. Unless Noted Otherwise.
○ -- Denotes Reaction Greater than 3,000 lbs. Reaction / # of Studs

All Walls Shown Are Considered Load Bearing

Plumbing Drop Notes

1. Plumbing drop locations shown are NOT exact.
2. Contractor to verify ALL plumbing drop locations prior to setting Floor Trusses.
3. Adjust spacing as needed not to exceed 24"oc.

Dimension Notes

1. All exterior wall to wall dimensions are to face of sheathing unless noted otherwise
2. All interior wall dimensions are to face of stud unless noted otherwise
3. All exterior wall to truss dimensions are to face of stud unless noted otherwise

Hatch Legend

- Second Floor Walls
- Box Storage
- Drop Beam
- Flush Beam

Connector Information					Nail Information	
Sym	Product	Manuf	Qty	Supported Member	Header	Truss
●	HUS410	USP	15	NA	16d/3-1/2"	16d/3-1/2"
○	MSH422	USP	2	Varies	10d/3"	10d/3"

Products

PlotID	Length	Product	Plies	Net Qty	Fab Type
BM1	4' 0"	2x10 SPF No.1	2	4	FF
BM2	9' 0"	1-3/4"x 14" LVL Kerto-S	2	2	FF
BM3	11' 0"	1-3/4"x 14" LVL Kerto-S	2	2	FF
GDH	21' 0"	1-3/4"x 16" LVL Kerto-S	2	2	FF
GDH2	13' 0"	1-3/4"x 11-7/8" LVL Kerto-S	2	2	FF

1 Truss Placement Plan
Scale: 1/4"=1'

▲ = Denotes Left End of Truss
(Reference Engineered Truss Drawing)

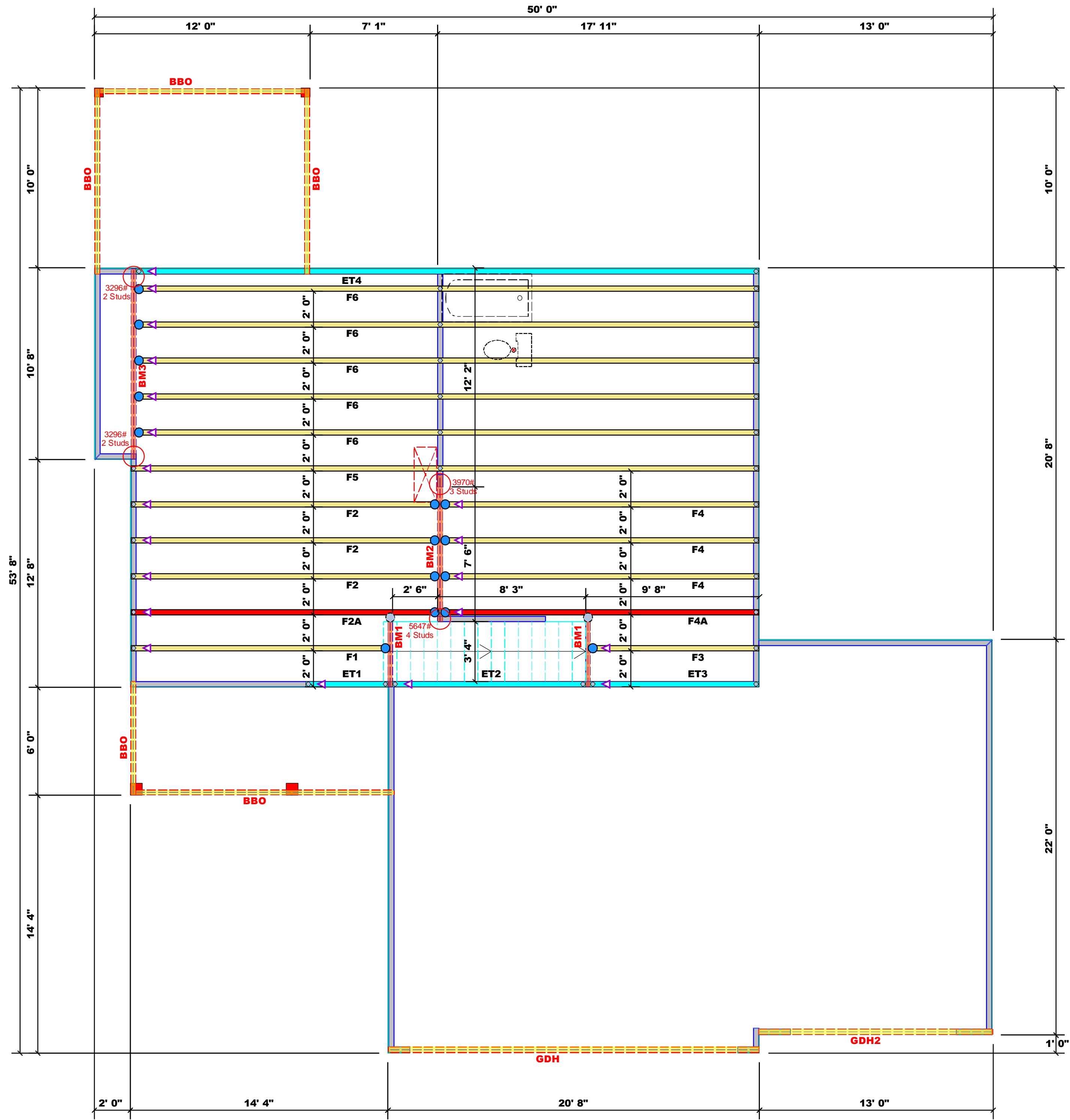

BUILDER	WEAVER DEVELOPMENT	CITY / CO.	SANFORD / HARNETT
JOB NAME	Lot 2 West Pointe III	ADDRESS	53 Hillwood Court
PLAN	Nicholson / 3GRF, CP	MODEL	Floor
SEAL DATE	N/A	DATE REV.	09/21/23
QUOTE #		DRAWN BY	Jonathan Landry
JOB #	J0623-2993	SALES REP.	Lenny Norris

THIS IS A TRUSS PLACEMENT DIAGRAM ONLY. These trusses are designed as individual building components to be incorporated into the building design at the specification of the building designer. See individual design sheets for each truss design identified on the placement drawing. The building designer is responsible for temporary and permanent bracing of the roof and floor system and for the overall structure. The design of the truss support structure including headers, beams, walls, and columns is the responsibility of the building designer. For general guidance regarding bracing, consult BCSI-B1 and BCSI-B3 provided with the truss delivery package or online @ sbciindustry.com

BM1 S-P-F #1 2.000" X 10.000" 2-Ply - PASSED

Level: Level

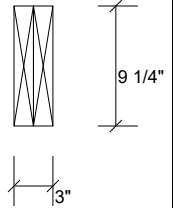
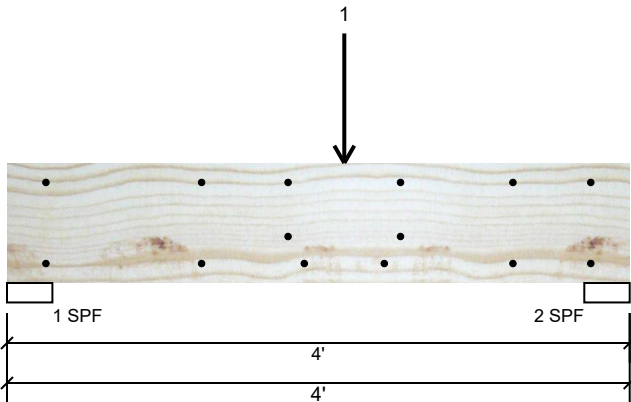

Member Information

Type:	Girder
Plies:	2
Moisture Condition:	Dry
Deflection LL:	480
Deflection TL:	360
Importance:	Normal - II
Temperature:	Temp <= 100°F

Application:	Floor
Design Method:	ASD
Building Code:	IBC/IRC 2015
Load Sharing:	No
Deck:	Not Checked

Reactions UNPATTERNED lb (Uplift)

Brg	Direction	Live	Dead	Snow	Wind	Const
1	Vertical	262	87	0	0	0
2	Vertical	317	106	0	0	0

Bearings

Bearing	Length	Dir.	Cap.	React D/L lb	Total	Ld. Case	Ld. Comb.
1 - SPF	3.500"	Vert	8%	87 / 262	350	L	D+L
2 - SPF	3.500"	Vert	9%	106 / 317	422	L	D+L

Analysis Results

Analysis	Actual	Location	Allowed	Capacity	Comb.	Case
Moment	677 ft-lb	2'2"	3431 ft-lb	0.197 (20%)	D+L	L
Unbraced	677 ft-lb	2'2"	3324 ft-lb	0.204 (20%)	D+L	L
Shear	422 lb	2'11 1/4"	2498 lb	0.169 (17%)	D+L	L
LL Defl inch (L/12864)	0.003	2' 5/8"	0.089 (L/480)	0.037 (4%)	L	L
TL Defl inch	0.004 (L/9648)	2' 5/8"	0.118 (L/360)	0.037 (4%)	D+L	L

Design Notes

- 1 Provide support to prevent lateral movement and rotation at the end bearings. Lateral support may also be required at the interior bearings by the building code.
- 2 Fasten all plies using 2 rows of 10d Box nails (.128x3") at 12" o.c. Maximum end distance not to exceed 6".
- 3 Refer to last page of calculations for fasteners required for specified loads.
- 4 Concentrated load fastener specification is in addition to hanger fasteners if a hanger is present.
- 5 Girders are designed to be supported on the bottom edge only.
- 6 Top must be laterally braced at end bearings.
- 7 Bottom must be laterally braced at end bearings.
- 8 Lateral slenderness ratio based on single ply width.

ID	Load Type	Location	Trib Width	Side	Dead 0.9	Live 1	Snow 1.15	Wind 1.6	Const. 1.25	Comments
1	Point	2-2-0		Near Face	193 lb	579 lb	0 lb	0 lb	0 lb	F1

Manufacturer Info	Comtech, Inc. 1001 S. Reilly Road, Suite #639 Fayetteville, NC USA 28314 910-864-TRUS

This design is valid until 11/3/2024

BM1 S-P-F #1 2.000" X 10.000" 2-Ply - PASSED

Level: Level

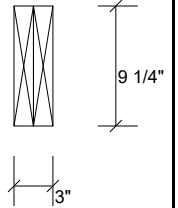
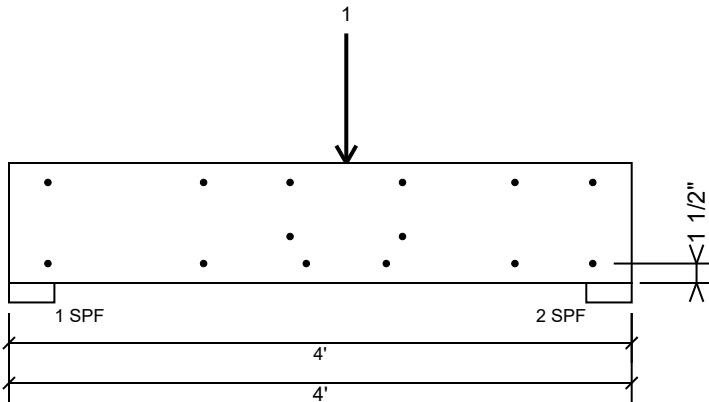

Multi-Ply Analysis

Fasten all plies using 2 rows of 10d Box nails (.128x3") at 12" o.c.. except for regions covered by concentrated load fastening. Maximum end distance not to exceed 6".

Capacity	0.0 %
Load	0.0 PLF
Yield Limit per Foot	157.4 PLF
Yield Limit per Fastener	78.7 lb.
Yield Mode	IV
Edge Distance	1 1/2"
Min. End Distance	3"
Load Combination	
Duration Factor	1.00

Concentrated Load

Fasten at concentrated side load at 2-2-0 with a minimum of (6) – 10d Box nails (.128x3") in the pattern shown.

Capacity	81.7 %
Load	386.0lb.
Total Yield Limit	472.2 lb.
Cg	1.0000
Yield Limit per Fastener	78.7 lb.
Yield Mode	IV
Load Combination	D+L
Duration Factor	1.00

Min/Max fastener distances for Concentrated Side Loads

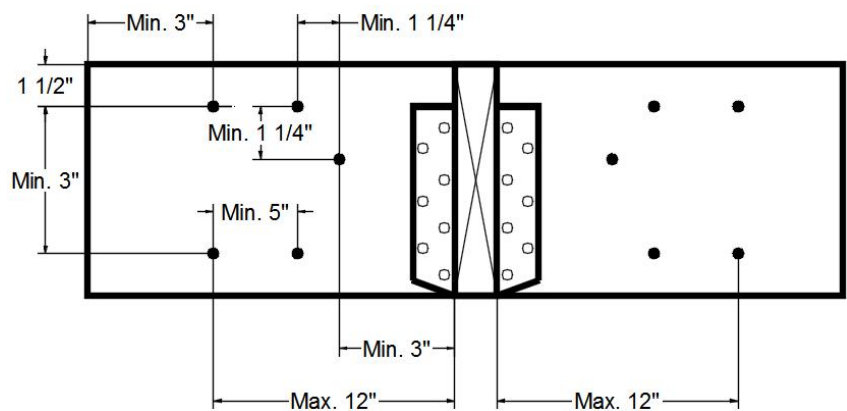

Manufacturer Info

Comtech, Inc.
 1001 S. Reilly Road, Suite #639
 Fayetteville, NC
 USA
 28314
 910-864-TRUS



This design is valid until 11/3/2024

BM2 Kerto-S LVL 1.750" X 14.000" 2-Ply - PASSED

Level: Level

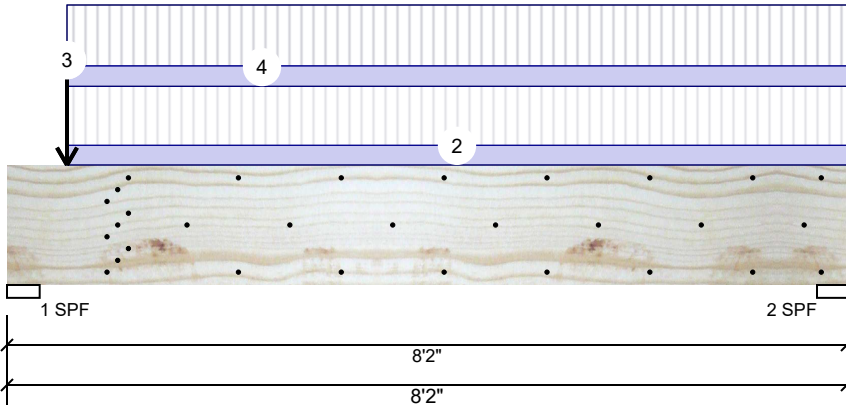

Member Information

Type:	Girder	Application:	Floor
Plies:	2	Design Method:	ASD
Moisture Condition:	Dry	Building Code:	IBC/IRC 2015
Deflection LL:	480	Load Sharing:	No
Deflection TL:	360	Deck:	Not Checked
Importance:	Normal - II		
Temperature:	Temp <= 100°F		

Reactions UNPATTERNED lb (Uplift)

Brg	Direction	Live	Dead	Snow	Wind	Const
1	Vertical	4199	1448	0	0	0
2	Vertical	2941	1029	0	0	0

Bearings

Bearing	Length	Dir.	Cap. React	D/L lb	Total	Ld. Case	Ld. Comb.
1 - SPF	3.813"	Vert	100%	1448 / 4199	5647	L	D+L
2 - SPF	3.500"	Vert	76%	1029 / 2941	3970	L	D+L

Analysis Results

Analysis	Actual	Location	Allowed	Capacity	Comb.	Case
Moment	7394 ft-lb	3'11 15/16"	26999 ft-lb	0.274 (27%)	D+L	L
Unbraced	7394 ft-lb	3'11 15/16"	13291 ft-lb	0.556 (56%)	D+L	L
Shear	5893 lb	1'5 13/16"	10453 lb	0.564 (56%)	D+L	L
LL Defl inch	0.050 (L/1859)	4' 5/8"	0.192 (L/480)	0.258 (26%)	L	L
TL Defl inch	0.067 (L/1378)	4' 5/8"	0.256 (L/360)	0.261 (26%)	D+L	L

Design Notes

- 1 Provide support to prevent lateral movement and rotation at the end bearings. Lateral support may also be required at the interior bearings by the building code.
- 2 Fasten all plies using 3 rows of 10d Box nails (.128x3") at 12" o.c. Maximum end distance not to exceed 6".
- 3 Refer to last page of calculations for fasteners required for specified loads.
- 4 Concentrated load fastener specification is in addition to hanger fasteners if a hanger is present.
- 5 Girders are designed to be supported on the bottom edge only.
- 6 Top must be laterally braced at end bearings.
- 7 Bottom must be laterally braced at end bearings.
- 8 Lateral slenderness ratio based on single ply width.

ID	Load Type	Location	Trib Width	Side	Dead 0.9	Live 1	Snow 1.15	Wind 1.6	Const. 1.25	Comments
1	Point	0-7-0		Far Face	321 lb	963 lb	0 lb	0 lb	0 lb	F2A
2	Part. Uniform	0-7-0 to 8-2-0		Far Face	116 PLF	347 PLF	0 PLF	0 PLF	0 PLF	F2
3	Point	0-7-0		Near Face	277 lb	831 lb	0 lb	0 lb	0 lb	F4A
4	Part. Uniform	0-7-0 to 8-2-0		Near Face	120 PLF	358 PLF	0 PLF	0 PLF	0 PLF	F4
	Self Weight				11 PLF					

<p>Notes</p> <p>Calculated Structural Designs is responsible only of the structural adequacy of this component based on the design criteria and loadings shown. It is the responsibility of the customer and/or the contractor to ensure the component suitability of the intended application, and to verify the dimensions and loads.</p> <p>Lumber</p> <ol style="list-style-type: none"> 1. Dry service conditions, unless noted otherwise 2. LVL not to be treated with fire retardant or corrosive chemicals 	<p>Handling & Installation</p> <ol style="list-style-type: none"> 1. LVL beams must not be cut or drilled 2. Refer to manufacturer's product information regarding installation requirements, multi-ply fastening details, beam strength values, and code approvals 3. Damaged Beams must not be used 4. Design assumes top edge is laterally restrained 5. Provide lateral support at bearing points to avoid lateral displacement and rotation 	<p>6. For flat roofs provide proper drainage to prevent ponding</p>	<p>Manufacturer Info</p> <p>Metsä Wood 301 Merritt 7 Building, 2nd Floor Norwalk, CT 06851 (800) 622-5850 www.metsawood.com/us</p>	<p>Comtech, Inc. 1001 S. Reilly Road, Suite #639 Fayetteville, NC USA 28314 910-864-TRUS</p>
			<p>This design is valid until 11/3/2024</p>	

BM2 Kerto-S LVL 1.750" X 14.000" 2-Ply - PASSED

Level: Level

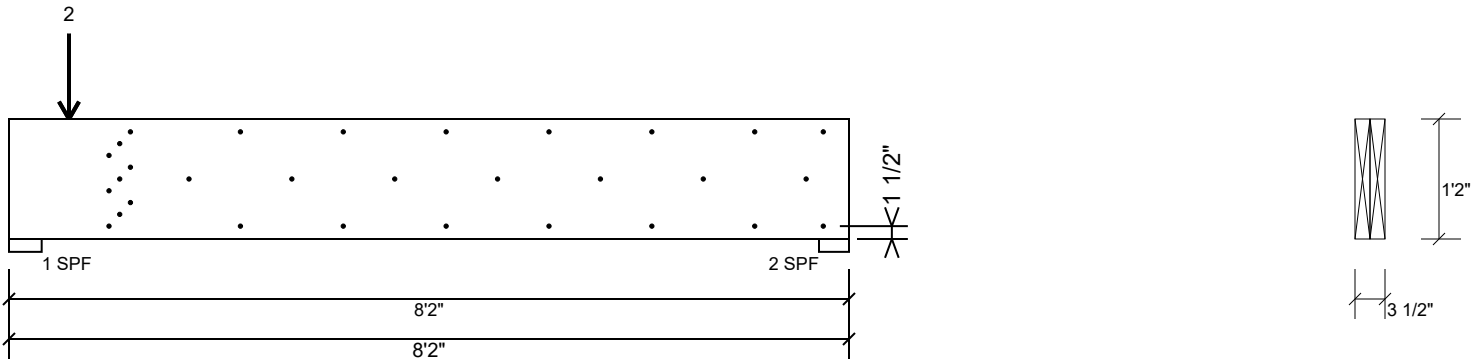

Multi-Ply Analysis

Fasten all plies using 3 rows of 10d Box nails (.128x3") at 12" o.c.. except for regions covered by concentrated load fastening. Maximum end distance not to exceed 6".

Capacity	97.3 %
Load	239.0 PLF
Yield Limit per Foot	245.6 PLF
Yield Limit per Fastener	81.9 lb.
Yield Mode	IV
Edge Distance	1 1/2"
Min. End Distance	3"
Load Combination	D+L
Duration Factor	1.00

Concentrated Load

Fasten at concentrated side load at 0-7-0 with a minimum of (9) – 10d Box nails (.128x3") in the pattern shown.

Capacity	87.2 %
Load	642.0lb.
Total Yield Limit	736.5 lb.
Cg	0.9998
Yield Limit per Fastener	81.9 lb.
Yield Mode	IV
Load Combination	D+L
Duration Factor	1.00

Min/Max fastener distances for Concentrated Side Loads

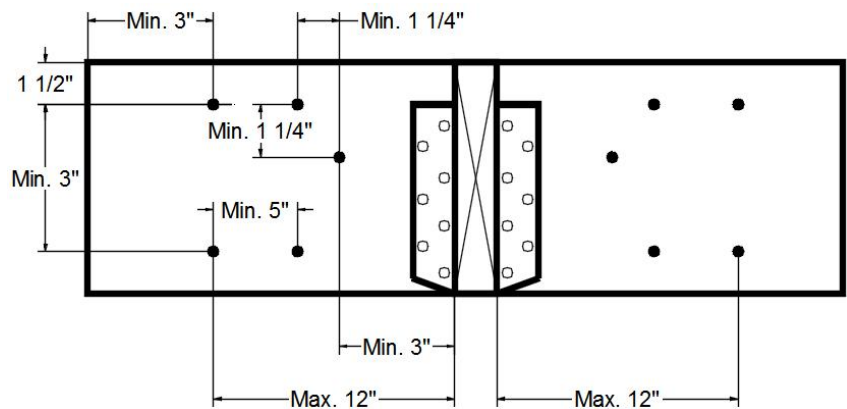

Notes

Calculated Structured Designs is responsible only of the structural adequacy of this component based on the design criteria and loadings shown. It is the responsibility of the customer and/or the contractor to ensure the component suitability of the intended application, and to verify the dimensions and loads.

Lumber

1. Dry service conditions, unless noted otherwise
2. LVL not to be treated with fire retardant or corrosive chemicals

Handling & Installation

1. LVL beams must not be cut or drilled
2. Refer to manufacturer's product information regarding installation requirements, multi-ply fastening details, beam strength values, and code approvals
3. Damaged Beams must not be used
4. Design assumes top edge is laterally restrained
5. Provide lateral support at bearing points to avoid lateral displacement and rotation

6. For flat roofs provide proper drainage to prevent ponding

Manufacturer Info

Metsä Wood
 301 Merritt 7 Building, 2nd Floor
 Norwalk, CT 06851
 (800) 622-5850
www.metsawood.com/us

Comtech, Inc.
 1001 S. Reilly Road, Suite #639
 Fayetteville, NC
 USA
 28314
 910-864-TRUS



This design is valid until 11/3/2024

BM3 Kerto-S LVL 1.750" X 14.000" 2-Ply - PASSED

Level: Level

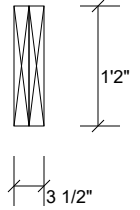
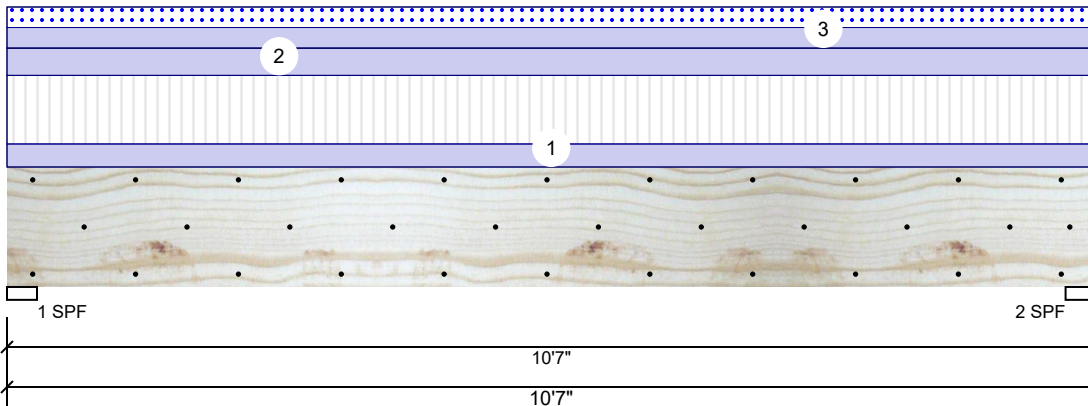

Member Information

Type:	Girder
Plies:	2
Moisture Condition:	Dry
Deflection LL:	480
Deflection TL:	360
Importance:	Normal - II
Temperature:	Temp <= 100°F

Application:	Floor
Design Method:	ASD
Building Code:	IBC/IRC 2015
Load Sharing:	No
Deck:	Not Checked

Reactions UNPATTERNED lb (Uplift)

Brg	Direction	Live	Dead	Snow	Wind	Const
1	Vertical	1593	1703	476	0	0
2	Vertical	1593	1703	476	0	0

Bearings

Bearing	Length	Dir.	Cap.	React D/L lb	Total	Ld. Case	Ld. Comb.
1 - SPF	3.500"	Vert	63%	1703 / 1593	3296	L	D+L
2 - SPF	3.500"	Vert	63%	1703 / 1593	3296	L	D+L

Analysis Results

Analysis	Actual	Location	Allowed	Capacity	Comb.	Case
Moment	7982 ft-lb	5'3 1/2"	26999 ft-lb	0.296 (30%)	D+L	L
Unbraced	7982 ft-lb	5'3 1/2"	10667 ft-lb	0.748 (75%)	D+L	L
Shear	2869 lb	1'5 1/2"	10453 lb	0.275 (27%)	D+L	L
LL Defl inch	0.054 (L/2270)	5'3 1/2"	0.253 (L/480)	0.211 (21%)	L	L
TL Defl inch	0.111 (L/1097)	5'3 1/2"	0.338 (L/360)	0.328 (33%)	D+L	L

Design Notes

- 1 Provide support to prevent lateral movement and rotation at the end bearings. Lateral support may also be required at the interior bearings by the building code.
- 2 Fasten all plies using 3 rows of 10d Box nails (.128x3") at 12" o.c. Maximum end distance not to exceed 6".
- 3 Refer to last page of calculations for fasteners required for specified loads.
- 4 Girders are designed to be supported on the bottom edge only.
- 5 Top loads must be supported equally by all plies.
- 6 Top must be laterally braced at end bearings.
- 7 Bottom must be laterally braced at end bearings.
- 8 Lateral slenderness ratio based on single ply width.

ID	Load Type	Location	Trib Width	Side	Dead 0.9	Live 1	Snow 1.15	Wind 1.6	Const. 1.25	Comments
1	Uniform			Near Face	101 PLF	301 PLF	0 PLF	0 PLF	0 PLF	F6
2	Uniform			Top	120 PLF	0 PLF	0 PLF	0 PLF	0 PLF	Wall
3	Uniform			Top	90 PLF	0 PLF	90 PLF	0 PLF	0 PLF	A1GE
	Self Weight				11 PLF					

Notes

Calculated Structured Designs is responsible only of the structural adequacy of this component based on the design criteria and loadings shown. It is the responsibility of the customer and/or the contractor to ensure the component suitability of the intended application, and to verify the dimensions and loads.

Lumber

1. Dry service conditions, unless noted otherwise
2. LVL not to be treated with fire retardant or corrosive chemicals

Handling & Installation

1. LVL beams must not be cut or drilled
2. Refer to manufacturer's product information regarding installation requirements, multi-ply fastening details, beam strength values, and code approvals
3. Damaged Beams must not be used
4. Design assumes top edge is laterally restrained
5. Provide lateral support at bearing points to avoid lateral displacement and rotation

6. For flat roofs provide proper drainage to prevent ponding

This design is valid until 11/3/2024

Manufacturer Info

Metsä Wood
 301 Merritt 7 Building, 2nd Floor
 Norwalk, CT 06851
 (800) 622-5850
www.metsawood.com/us

Comtech, Inc.
 1001 S. Reilly Road, Suite #639
 Fayetteville, NC
 USA
 28314
 910-864-TRUS



BM3 Kerto-S LVL 1.750" X 14.000" 2-Ply - PASSED

Level: Level

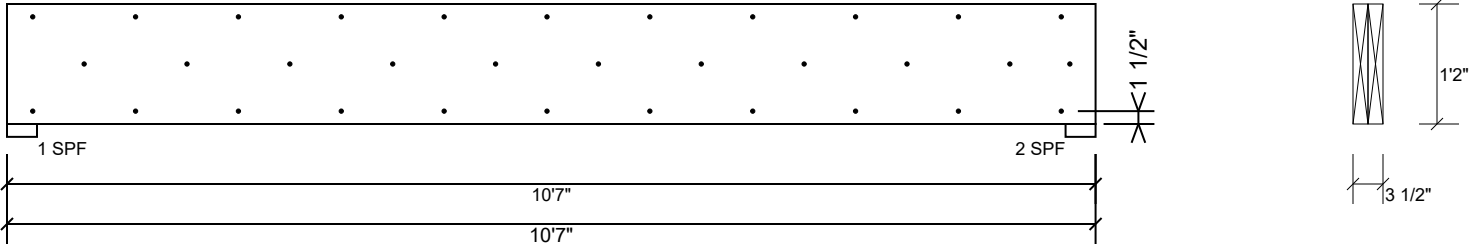

Multi-Ply Analysis

Fasten all plies using 3 rows of 10d Box nails (.128x3") at 12" o.c.. Maximum end distance not to exceed 6".

Capacity	81.9 %
Load	201.0 PLF
Yield Limit per Foot	245.6 PLF
Yield Limit per Fastener	81.9 lb.
Yield Mode	IV
Edge Distance	1 1/2"
Min. End Distance	3"
Load Combination	D+L
Duration Factor	1.00

Notes

Calculated Structured Designs is responsible only of the structural adequacy of this component based on the design criteria and loadings shown. It is the responsibility of the customer and/or the contractor to ensure the component suitability of the intended application, and to verify the dimensions and loads.

Lumber

1. Dry service conditions, unless noted otherwise
2. LVL not to be treated with fire retardant or corrosive

chemicals

Handling & Installation

1. LVL beams must not be cut or drilled
2. Refer to manufacturer's product information regarding installation requirements, multi-ply fastening details, beam strength values, and code approvals
3. Damaged Beams must not be used
4. Design assumes top edge is laterally restrained
5. Provide lateral support at bearing points to avoid lateral displacement and rotation

6. For flat roofs provide proper drainage to prevent ponding

This design is valid until 11/3/2024

Manufacturer Info

Metsä Wood
 301 Merritt 7 Building, 2nd Floor
 Norwalk, CT 06851
 (800) 622-5850
www.metsawood.com/us

Comtech, Inc.
 1001 S. Reilly Road, Suite #639
 Fayetteville, NC
 USA
 28314
 910-864-TRUS



GDH Kerto-S LVL 1.750" X 16.000" 2-Ply - PASSED

Level: Level

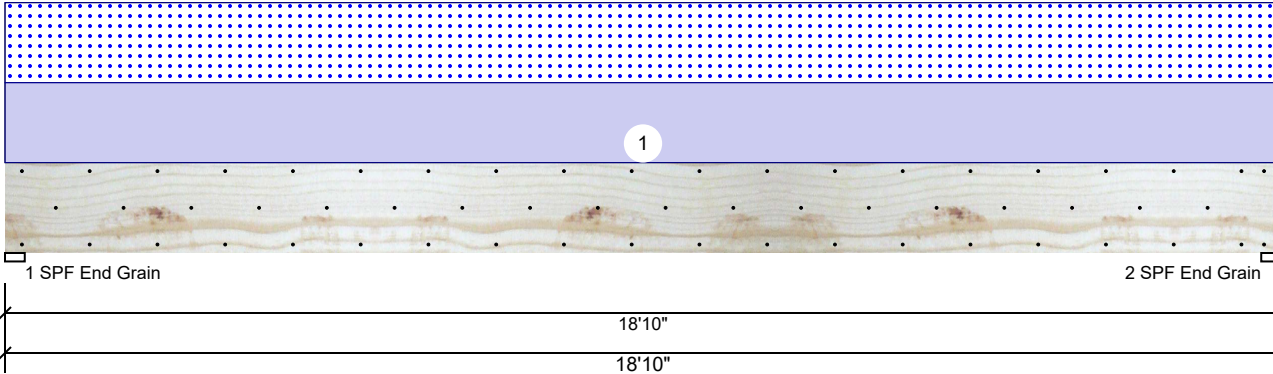

Member Information

Type:	Girder	Application:	Floor
Plies:	2	Design Method:	ASD
Moisture Condition:	Dry	Building Code:	IBC/IRC 2015
Deflection LL:	480	Load Sharing:	No
Deflection TL:	360	Deck:	Not Checked
Importance:	Normal - II		
Temperature:	Temp <= 100°F		

Reactions UNPATTERNED lb (Uplift)

Brg	Direction	Live	Dead	Snow	Wind	Const
1	Vertical	0	1953	1836	0	0
2	Vertical	0	1953	1836	0	0

Bearings

Bearing	Length	Dir.	Cap.	React D/L	Total	Ld. Case	Ld. Comb.
1 - SPF End Grain	3.500"	Vert	37%	1953 / 1836	3790	L	D+S
2 - SPF End Grain	3.500"	Vert	37%	1953 / 1836	3790	L	D+S

Analysis Results

Analysis	Actual	Location	Allowed	Capacity	Comb.	Case
Moment	17024 ft-lb	9'5"	39750 ft-lb	0.428 (43%)	D+S	L
Unbraced	17024 ft-lb	9'5"	17101 ft-lb	0.995 (100%)	D+S	L
Shear	3152 lb	17'2 1/2"	13739 lb	0.229 (23%)	D+S	L
LL Defl inch	0.227 (L/971)	9'5 1/16"	0.460 (L/480)	0.494 (49%)	S	L
TL Defl inch	0.469 (L/471)	9'5 1/16"	0.613 (L/360)	0.765 (76%)	D+S	L

Design Notes

- Provide support to prevent lateral movement and rotation at the end bearings. Lateral support may also be required at the interior bearings by the building code.
- Fasten all plies using 3 rows of 10d Box nails (.128x3") at 12" o.c. Maximum end distance not to exceed 6".
- Refer to last page of calculations for fasteners required for specified loads.
- Girders are designed to be supported on the bottom edge only.
- Top loads must be supported equally by all plies.
- Top must be laterally braced at a maximum of 6'10 3/4" o.c.
- Bottom must be laterally braced at end bearings.
- Lateral slenderness ratio based on single ply width.

ID	Load Type	Location	Trib Width	Side	Dead 0.9	Live 1	Snow 1.15	Wind 1.6	Const. 1.25	Comments
1	Uniform			Top	195 PLF	0 PLF	195 PLF	0 PLF	0 PLF	C1GE
	Self Weight				12 PLF					

Notes

Calculated Structural Designs is responsible only of the structural adequacy of this component based on the design criteria and loadings shown. It is the responsibility of the customer and/or the contractor to ensure the component suitability of the intended application, and to verify the dimensions and loads.

Lumber

- Dry service conditions, unless noted otherwise
- LVL not to be treated with fire retardant or corrosive chemicals

Handling & Installation

- LVL beams must not be cut or drilled
- Refer to manufacturer's product information regarding installation requirements, multi-ply fastening details, beam strength values, and code approvals
- Damaged Beams must not be used
- Design assumes top edge is laterally restrained
- Provide lateral support at bearing points to avoid lateral displacement and rotation

6. For flat roofs provide proper drainage to prevent ponding

This design is valid until 11/3/2024

Manufacturer Info

Metsä Wood
 301 Merritt 7 Building, 2nd Floor
 Norwalk, CT 06851
 (800) 622-5850
www.metsawood.com/us

Comtech, Inc.
 1001 S. Reilly Road, Suite #639
 Fayetteville, NC
 USA
 28314
 910-864-TRUS



GDH Kerto-S LVL 1.750" X 16.000" 2-Ply - PASSED

Level: Level

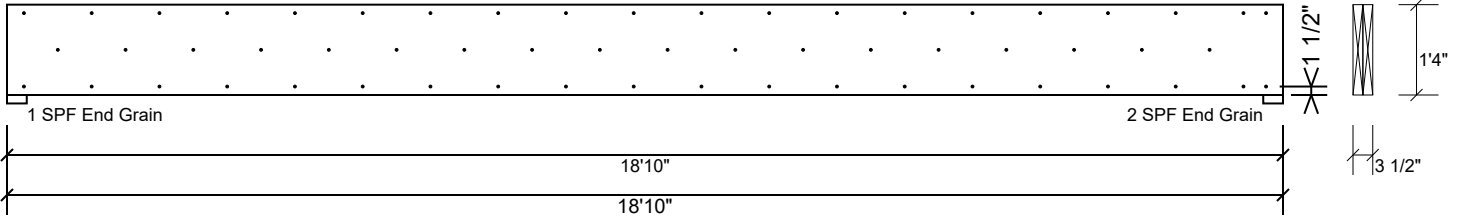

Multi-Ply Analysis

Fasten all plies using 3 rows of 10d Box nails (.128x3") at 12" o.c.. Maximum end distance not to exceed 6".

Capacity	0.0 %
Load	0.0 PLF
Yield Limit per Foot	245.6 PLF
Yield Limit per Fastener	81.9 lb.
Yield Mode	IV
Edge Distance	1 1/2"
Min. End Distance	3"
Load Combination	
Duration Factor	1.00

Notes

Calculated Structured Designs is responsible only of the structural adequacy of this component based on the design criteria and loadings shown. It is the responsibility of the customer and/or the contractor to ensure the component suitability of the intended application, and to verify the dimensions and loads.

Lumber

1. Dry service conditions, unless noted otherwise
2. LVL not to be treated with fire retardant or corrosive

chemicals

Handling & Installation

1. LVL beams must not be cut or drilled
2. Refer to manufacturer's product information regarding installation requirements, multi-ply fastening details, beam strength values, and code approvals
3. Damaged Beams must not be used
4. Design assumes top edge is laterally restrained
5. Provide lateral support at bearing points to avoid lateral displacement and rotation

6. For flat roofs provide proper drainage to prevent ponding

This design is valid until 11/3/2024

Manufacturer Info

Metsä Wood
 301 Merritt 7 Building, 2nd Floor
 Norwalk, CT 06851
 (800) 622-5850
www.metsawood.com/us

Comtech, Inc.
 1001 S. Reilly Road, Suite #639
 Fayetteville, NC
 USA
 28314
 910-864-TRUS



GDH2 Kerto-S LVL 1.750" X 11.875" 2-Ply - PASSED

Level: Level

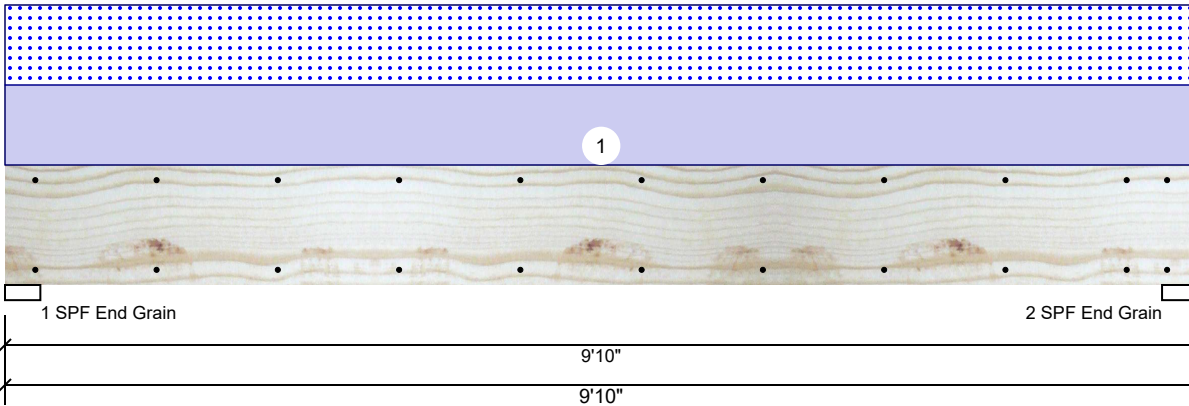

Member Information

Type:	Girder	Application:	Floor
Plies:	2	Design Method:	ASD
Moisture Condition:	Dry	Building Code:	IBC/IRC 2015
Deflection LL:	480	Load Sharing:	No
Deflection TL:	360	Deck:	Not Checked
Importance:	Normal - II		
Temperature:	Temp <= 100°F		

Reactions UNPATTERNED lb (Uplift)

Brg	Direction	Live	Dead	Snow	Wind	Const
1	Vertical	0	1270	1224	0	0
2	Vertical	0	1270	1224	0	0

Bearings

Bearing	Length	Dir.	Cap.	React D/L lb	Total	Ld. Case	Ld. Comb.
1 - SPF End Grain	3.500"	Vert	24%	1270 / 1224	2494	L	D+S
2 - SPF End Grain	3.500"	Vert	24%	1270 / 1224	2494	L	D+S

Analysis Results

Analysis	Actual	Location	Allowed	Capacity	Comb.	Case
Moment	5573 ft-lb	4'11"	22897 ft-lb	0.243 (24%)	D+S	L
Unbraced	5573 ft-lb	4'11"	9857 ft-lb	0.565 (57%)	D+S	L
Shear	1853 lb	1'3 3/8"	10197 lb	0.182 (18%)	D+S	L
LL Defl inch	0.052 (L/2168)	4'11"	0.234 (L/480)	0.221 (22%)	S	L
TL Defl inch	0.106 (L/1064)	4'11"	0.312 (L/360)	0.338 (34%)	D+S	L

Design Notes

- 1 Provide support to prevent lateral movement and rotation at the end bearings. Lateral support may also be required at the interior bearings by the building code.
- 2 Fasten all plies using 2 rows of 10d Box nails (.128x3") at 12" o.c. Maximum end distance not to exceed 6".
- 3 Refer to last page of calculations for fasteners required for specified loads.
- 4 Girders are designed to be supported on the bottom edge only.
- 5 Top loads must be supported equally by all plies.
- 6 Top must be laterally braced at end bearings.
- 7 Bottom must be laterally braced at end bearings.
- 8 Lateral slenderness ratio based on single ply width.

ID	Load Type	Location	Trib Width	Side	Dead 0.9	Live 1	Snow 1.15	Wind 1.6	Const. 1.25	Comments
1	Uniform			Top	249 PLF	0 PLF	249 PLF	0 PLF	0 PLF	D1
	Self Weight				9 PLF					

Notes

Calculated Structured Designs is responsible only of the structural adequacy of this component based on the design criteria and loadings shown. It is the responsibility of the customer and/or the contractor to ensure the component suitability of the intended application, and to verify the dimensions and loads.

Lumber

1. Dry service conditions, unless noted otherwise
2. LVL not to be treated with fire retardant or corrosive chemicals

Handling & Installation

1. LVL beams must not be cut or drilled
2. Refer to manufacturer's product information regarding installation requirements, multi-ply fastening details, beam strength values, and code approvals
3. Damaged Beams must not be used
4. Design assumes top edge is laterally restrained
5. Provide lateral support at bearing points to avoid lateral displacement and rotation

6. For flat roofs provide proper drainage to prevent ponding

This design is valid until 11/3/2024

Manufacturer Info

Metsä Wood
 301 Merritt 7 Building, 2nd Floor
 Norwalk, CT 06851
 (800) 622-5850
www.metsawood.com/us

Comtech, Inc.
 1001 S. Reilly Road, Suite #639
 Fayetteville, NC
 USA
 28314
 910-864-TRUS



GDH2 Kerto-S LVL 1.750" X 11.875" 2-Ply - PASSED

Level: Level

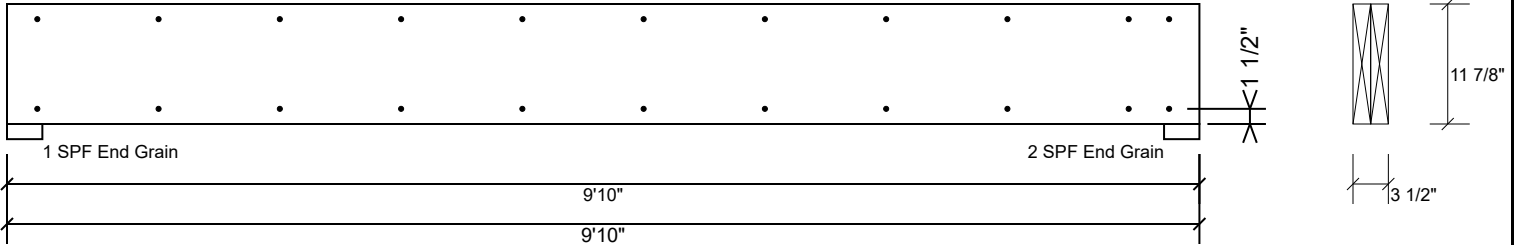

Multi-Ply Analysis

Fasten all plies using 2 rows of 10d Box nails (.128x3") at 12" o.c.. Maximum end distance not to exceed 6".

Capacity	0.0 %
Load	0.0 PLF
Yield Limit per Foot	163.7 PLF
Yield Limit per Fastener	81.9 lb.
Yield Mode	IV
Edge Distance	1 1/2"
Min. End Distance	3"
Load Combination	
Duration Factor	1.00

Notes

Calculated Structured Designs is responsible only of the structural adequacy of this component based on the design criteria and loadings shown. It is the responsibility of the customer and/or the contractor to ensure the component suitability of the intended application, and to verify the dimensions and loads.

Lumber

1. Dry service conditions, unless noted otherwise
2. LVL not to be treated with fire retardant or corrosive

chemicals

Handling & Installation

1. LVL beams must not be cut or drilled
2. Refer to manufacturer's product information regarding installation requirements, multi-ply fastening details, beam strength values, and code approvals
3. Damaged Beams must not be used
4. Design assumes top edge is laterally restrained
5. Provide lateral support at bearing points to avoid lateral displacement and rotation

6. For flat roofs provide proper drainage to prevent ponding

This design is valid until 11/3/2024

Manufacturer Info

Metsä Wood
 301 Merritt 7 Building, 2nd Floor
 Norwalk, CT 06851
 (800) 622-5850
www.metsawood.com/us

Comtech, Inc.
 1001 S. Reilly Road, Suite #639
 Fayetteville, NC
 USA
 28314
 910-864-TRUS



RE: J0623-2993
Lot 2 West Pointe III

Trenco
818 Soundside Rd
Edenton, NC 27932

Site Information:

Customer: Weaver Development Project Name: J0623-2993
Lot/Block: 2 Model: Nicholson
Address: 53 Hillwood Court Subdivision: West Pointe III
City: Sanford State: NC

General Truss Engineering Criteria & Design Loads (Individual Truss Design Drawings Show Special Loading Conditions):

Design Code: IRC2015/TPI2014 Design Program: MiTek 20/20 8.4
Wind Code: N/A Wind Speed: N/A mph
Roof Load: N/A psf Floor Load: 55.0 psf

This package includes 12 individual, dated Truss Design Drawings and 0 Additional Drawings.

No.	Seal#	Truss Name	Date
1	I57899244	ET1	4/20/2023
2	I57899245	ET2	4/20/2023
3	I57899246	ET3	4/20/2023
4	I57899247	ET4	4/20/2023
5	I57899248	F1	4/20/2023
6	I57899249	F2	4/20/2023
7	I57899250	F2A	4/20/2023
8	I57899251	F3	4/20/2023
9	I57899252	F4	4/20/2023
10	I57899253	F4A	4/20/2023
11	I57899254	F5	4/20/2023
12	I57899255	F6	4/20/2023

The truss drawing(s) referenced above have been prepared by Truss Engineering Co. under my direct supervision based on the parameters provided by Comtech, Inc - Fayetteville.

Truss Design Engineer's Name: Gilbert, Eric

My license renewal date for the state of North Carolina is December 31, 2023.

North Carolina COA: C-0844

IMPORTANT NOTE: The seal on these truss component designs is a certification that the engineer named is licensed in the jurisdiction(s) identified and that the designs comply with ANSI/TPI 1. These designs are based upon parameters shown (e.g., loads, supports, dimensions, shapes and design codes), which were given to TRENCO. Any project specific information included is for TRENCO customers file reference purpose only, and was not taken into account in the preparation of these designs. TRENCO has not independently verified the applicability of the design parameters or the designs for any particular building. Before use, the building designer should verify applicability of design parameters and properly incorporate these designs into the overall building design per ANSI/TPI 1, Chapter 2.



April 20, 2023

Job J0623-2993	Truss ET1	Truss Type GABLE	Qty 1	Ply 1	Lot 2 West Pointe III	157899244
-------------------	--------------	---------------------	----------	----------	-----------------------	-----------

Comtech, Inc., Fayetteville, NC 28309

8.430 s Jan 6 2022 MiTek Industries, Inc. Thu Apr 20 16:12:09 2023 Page 1
 ID:uB1kUybQLa2UVI5EAk1M8Myf?Wk-8fyBP?x1zPDmjg7r3umh4LufzFhPwzrsG0YZ6ozOmRk

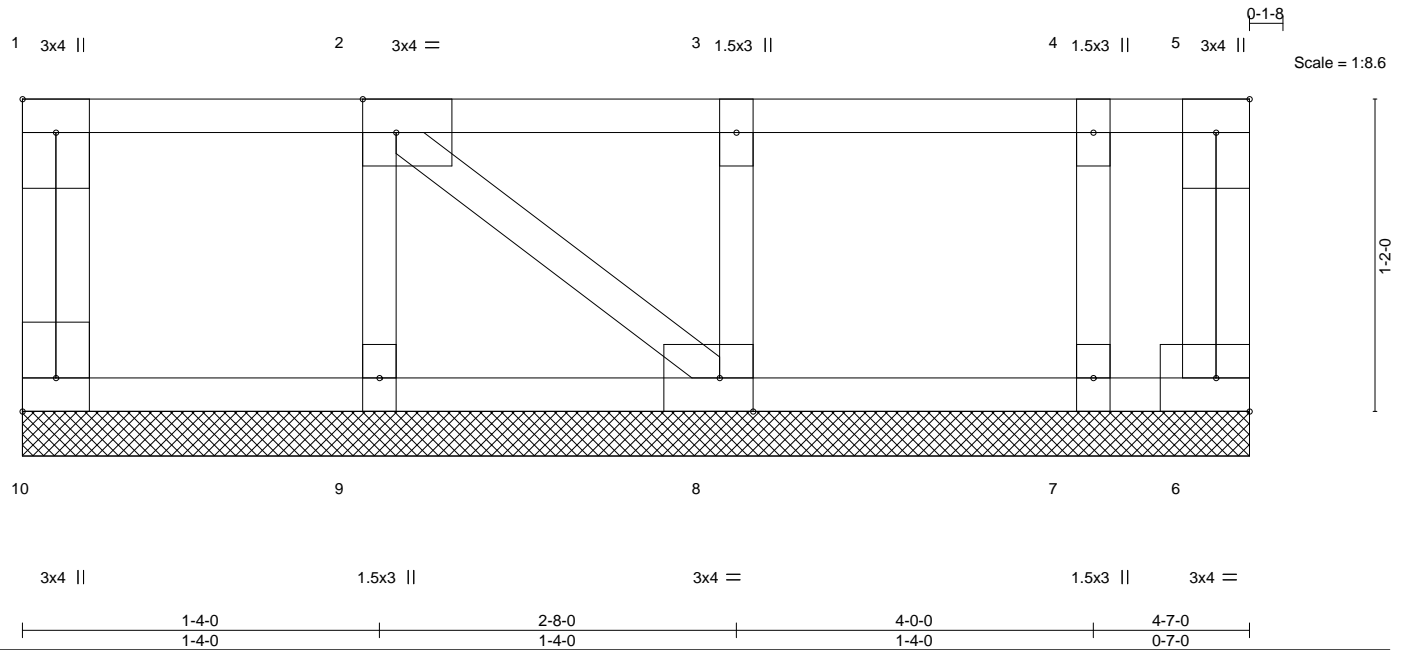

Plate Offsets (X,Y)--		[1:Edge,0-1-8], [2:0-1-8,Edge], [8:0-1-8,Edge], [10:Edge,0-1-8]			
LOADING (psf)	SPACING-	CSI.	DEFL.	PLATES	GRIP
TCLL 40.0	2-0-0	TC 0.06	in (loc) l/defl L/d	MT20	244/190
TCDL 10.0	Plate Grip DOL 1.00	BC 0.01	Vert(LL) n/a - n/a 999		
BCLL 0.0	Lumber DOL 1.00	WB 0.03	Vert(CT) n/a - n/a 999		
BCDL 5.0	Rep Stress Incr YES	Matrix-P	Horz(CT) 0.00 6 n/a n/a		
	Code IRC2015/TPI2014			Weight: 25 lb	FT = 20%F, 11%E

LUMBER-	BRACING-
TOP CHORD 2x4 SP No.1(flat)	TOP CHORD Structural wood sheathing directly applied or 4-7-0 oc purlins, except end verticals.
BOT CHORD 2x4 SP No.1(flat)	BOT CHORD Rigid ceiling directly applied or 10-0-0 oc bracing.
WEBS 2x4 SP No.3(flat)	
OTHERS 2x4 SP No.3(flat)	

REACTIONS. All bearings 4-7-0.
 (lb) - Max Uplift All uplift 100 lb or less at joint(s) 6
 Max Grav All reactions 250 lb or less at joint(s) 10, 6, 9, 8, 7

FORCES. (lb) - Max. Comp./Max. Ten. - All forces 250 (lb) or less except when shown.

- NOTES-**
- 1) Plates checked for a plus or minus 1 degree rotation about its center.
 - 2) Gable requires continuous bottom chord bearing.
 - 3) Truss to be fully sheathed from one face or securely braced against lateral movement (i.e. diagonal web).
 - 4) Gable studs spaced at 1-4-0 oc.
 - 5) Provide mechanical connection (by others) of truss to bearing plate capable of withstanding 100 lb uplift at joint(s) 6.
 - 6) This truss is designed in accordance with the 2015 International Residential Code sections R502.11.1 and R802.10.2 and referenced standard ANSI/TPI 1.
 - 7) Recommend 2x6 strongbacks, on edge, spaced at 10-0-0 oc and fastened to each truss with 3-10d (0.131" X 3") nails. Strongbacks to be attached to walls at their outer ends or restrained by other means.
 - 8) CAUTION, Do not erect truss backwards.

LOAD CASE(S) Standard



April 20, 2023

WARNING - Verify design parameters and READ NOTES ON THIS AND INCLUDED MITEK REFERENCE PAGE MII-7473 rev. 1/2/2023 BEFORE USE.
 Design valid for use only with MiTek® connectors. This design is based only upon parameters shown, and is for an individual building component, not a truss system. Before use, the building designer must verify the applicability of design parameters and properly incorporate this design into the overall building design. Bracing indicated is to prevent buckling of individual truss web and/or chord members only. Additional temporary and permanent bracing is always required for stability and to prevent collapse with possible personal injury and property damage. For general guidance regarding the fabrication, storage, delivery, erection and bracing of trusses and truss systems, see **ANSI/TPI1 Quality Criteria and DSB-22** available from Truss Plate Institute (www.tpinst.org) and **BCSI Building Component Safety Information** available from the Structural Building Component Association (www.sbcacomponents.com)

ENGINEERING BY
TRENCO
 A MiTek Affiliate
 818 Soundside Road
 Edenton, NC 27932

Job J0623-2993	Truss ET2	Truss Type GABLE	Qty 1	Ply 1	Lot 2 West Pointe III Job Reference (optional)	157899245
-------------------	--------------	---------------------	----------	----------	---	-----------

Comtech, Inc. Fayetteville, NC - 28314,

8.430 s Jan 6 2022 MiTek Industries, Inc. Thu Apr 20 14:52:27 2023 Page 1
ID:uB1kUybQLa2UVI5EAk1M8Myf?Wk-RfC?PsB70Hq3NSgPqnL8w3uITXbGKWrCDoi7J4zJC?f

0-1-8

Scale = 1:17.7

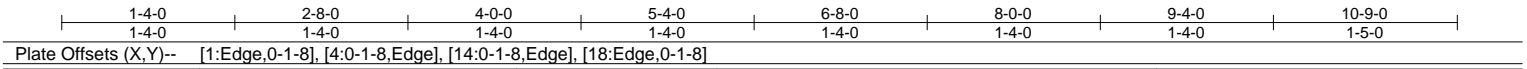
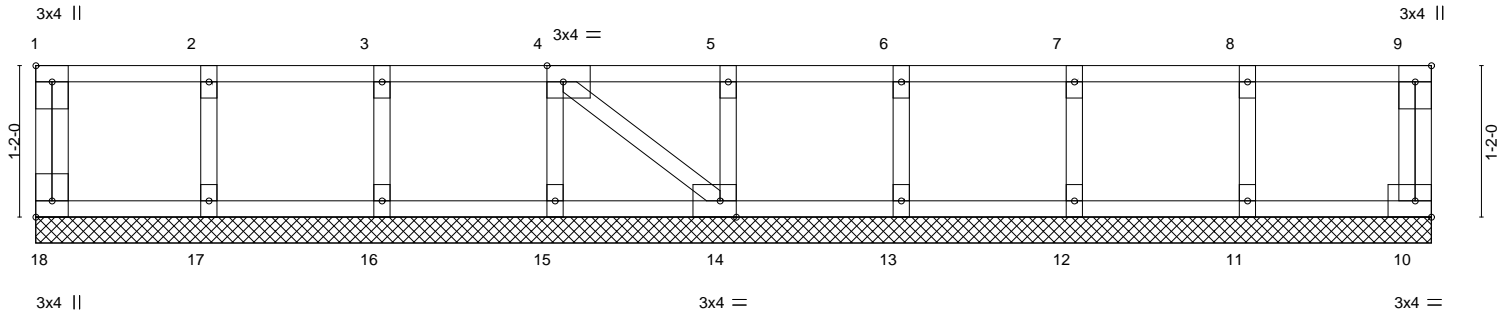

LOADING (psf)	SPACING-	2-0-0	CSI.	DEFL.	in (loc)	l/defl	L/d	PLATES	GRIP
TCLL 40.0	Plate Grip DOL	1.00	TC 0.07	Vert(LL)	n/a	-	n/a	MT20	244/190
TCDL 10.0	Lumber DOL	1.00	BC 0.01	Vert(CT)	n/a	-	n/a		
BCLL 0.0	Rep Stress Incr	YES	WB 0.03	Horz(CT)	0.00	14	n/a		
BCDL 5.0	Code IRC2015/TPI2014		Matrix-S						
								Weight: 49 lb	FT = 20%F, 11%E

LUMBER-	BRACING-
TOP CHORD 2x4 SP No.1(flat)	TOP CHORD Structural wood sheathing directly applied or 10-0-0 oc purlins, except end verticals.
BOT CHORD 2x4 SP No.1(flat)	BOT CHORD Rigid ceiling directly applied or 10-0-0 oc bracing.
WEBS 2x4 SP No.3(flat)	
OTHERS 2x4 SP No.3(flat)	

REACTIONS. All bearings 10-9-0.
(lb) - Max Grav All reactions 250 lb or less at joint(s) 18, 10, 17, 16, 15, 14, 13, 12, 11

FORCES. (lb) - Max. Comp./Max. Ten. - All forces 250 (lb) or less except when shown.

- NOTES-**
- All plates are 1.5x3 MT20 unless otherwise indicated.
 - Plates checked for a plus or minus 1 degree rotation about its center.
 - Gable requires continuous bottom chord bearing.
 - Truss to be fully sheathed from one face or securely braced against lateral movement (i.e. diagonal web).
 - Gable studs spaced at 1-4-0 oc.
 - Recommend 2x6 strongbacks, on edge, spaced at 10-0-0 oc and fastened to each truss with 3-10d (0.131" X 3") nails. Strongbacks to be attached to walls at their outer ends or restrained by other means.
 - CAUTION, Do not erect truss backwards.

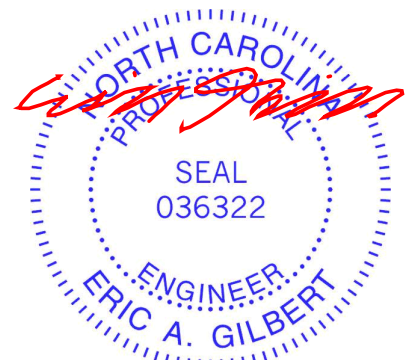

April 20, 2023

Job J0623-2993	Truss ET3	Truss Type GABLE	Qty 1	Ply 1	Lot 2 West Pointe III Job Reference (optional)	157899246
-------------------	--------------	---------------------	----------	----------	---	-----------

Comtech, Inc. Fayetteville, NC - 28314,

8.430 s Jan 6 2022 MiTek Industries, Inc. Thu Apr 20 14:52:28 2023 Page 1
ID:uB1kUybQLa2UVI5EAk1M8Myf?Wk-RfC?PsB70Hq3NSgPqnL8w3uITXbGKWrcDdoi7J4zJC?f

0.1:8

Scale = 1:17.2

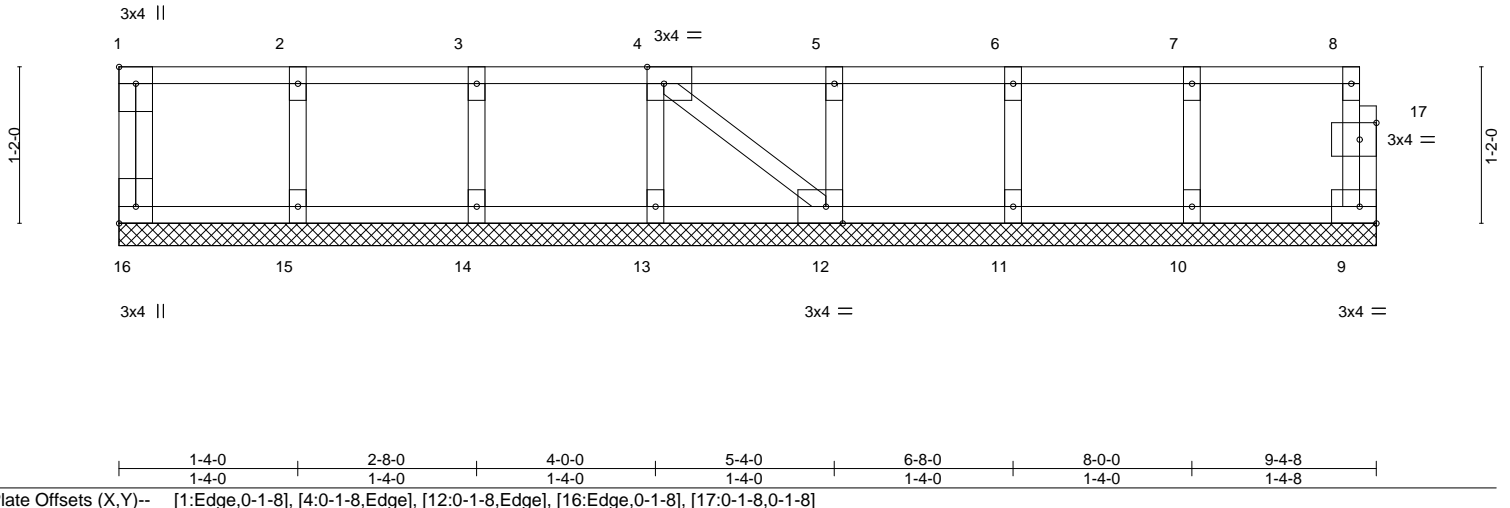

LOADING (psf)	SPACING-	2-0-0	CSI.	DEFL.	in (loc)	l/defl	L/d	PLATES	GRIP
TCLL 40.0	Plate Grip DOL	1.00	TC 0.06	Vert(LL)	n/a	-	n/a	MT20	244/190
TCDL 10.0	Lumber DOL	1.00	BC 0.01	Vert(CT)	n/a	-	n/a		
BCLL 0.0	Rep Stress Incr	YES	WB 0.03	Horz(CT)	0.00	9	n/a		
BCDL 5.0	Code IRC2015/TPI2014		Matrix-S						
								Weight: 43 lb	FT = 20%F, 11%E

LUMBER-	BRACING-
TOP CHORD 2x4 SP No.1(flat)	TOP CHORD Structural wood sheathing directly applied or 6-0-0 oc purlins, except end verticals.
BOT CHORD 2x4 SP No.1(flat)	BOT CHORD Rigid ceiling directly applied or 10-0-0 oc bracing.
WEBS 2x4 SP No.3(flat)	
OTHERS 2x4 SP No.3(flat)	

REACTIONS. All bearings 9-4-8.
(lb) - Max Grav All reactions 250 lb or less at joint(s) 16, 9, 15, 14, 13, 12, 11, 10

FORCES. (lb) - Max. Comp./Max. Ten. - All forces 250 (lb) or less except when shown.

- NOTES-**
- All plates are 1.5x3 MT20 unless otherwise indicated.
 - Plates checked for a plus or minus 1 degree rotation about its center.
 - Gable requires continuous bottom chord bearing.
 - Truss to be fully sheathed from one face or securely braced against lateral movement (i.e. diagonal web).
 - Gable studs spaced at 1-4-0 oc.
 - Recommend 2x6 strongbacks, on edge, spaced at 10-0-0 oc and fastened to each truss with 3-10d (0.131" X 3") nails. Strongbacks to be attached to walls at their outer ends or restrained by other means.
 - CAUTION, Do not erect truss backwards.



April 20, 2023

<p>WARNING - Verify design parameters and READ NOTES ON THIS AND INCLUDED MITEK REFERENCE PAGE MII-7473 rev. 1/2/2023 BEFORE USE.</p> <p>Design valid for use only with MiTek® connectors. This design is based only upon parameters shown, and is for an individual building component, not a truss system. Before use, the building designer must verify the applicability of design parameters and properly incorporate this design into the overall building design. Bracing indicated is to prevent buckling of individual truss web and/or chord members only. Additional temporary and permanent bracing is always required for stability and to prevent collapse with possible personal injury and property damage. For general guidance regarding the fabrication, storage, delivery, erection and bracing of trusses and truss systems, see ANSI/TP1 Quality Criteria and DSB-22 available from Truss Plate Institute (www.tpinst.org) and BCSI Building Component Safety Information available from the Structural Building Component Association (www.sbcacomponents.com)</p>	<p>ENGINEERING BY</p>  <p>A MiTek Affiliate</p> <p>818 Soundside Road Edenton, NC 27932</p>
--	--

Job J0623-2993	Truss ET4	Truss Type GABLE	Qty 1	Ply 1	Lot 2 West Pointe III I57899247 Job Reference (optional)
-------------------	--------------	---------------------	----------	----------	--

Comtech, Inc. Fayetteville, NC - 28314,

8.430 s Jan 6 2022 MiTek Industries, Inc. Thu Apr 20 14:52:30 2023 Page 1
ID:uB1kUybQLa2UVI5EAk1M8Myf?Wk-RfC?PsB70Hq3NSgPqnL8w3uITXbGKWrCDoi7J4zJC?f

0-1/8

0-1/8

Scale = 1:57.9

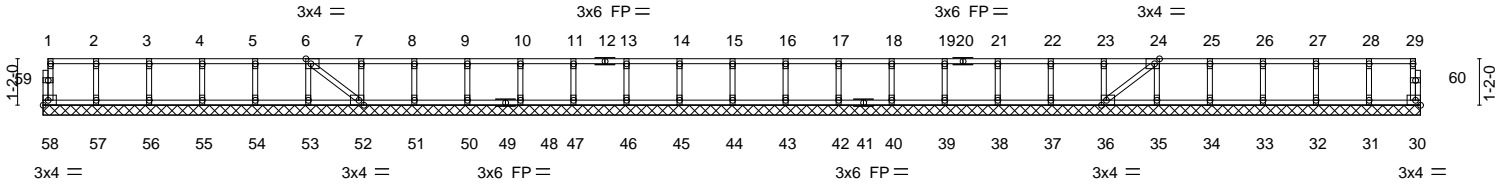

1-4-0	2-8-0	4-0-0	5-4-0	6-8-0	8-0-0	9-4-0	10-8-0	12-0-0	13-4-0	14-8-0	16-0-0	17-4-0	18-8-0	20-0-0	21-4-0	22-8-0	24-0-0	25-4-0	26-8-0	28-0-0	29-4-0	30-8-0	32-0-0	33-4-0	34-7-8
1-4-0	1-4-0	1-4-0	1-4-0	1-4-0	1-4-0	1-4-0	1-4-0	1-4-0	1-4-0	1-4-0	1-4-0	1-4-0	1-4-0	1-4-0	1-4-0	1-4-0	1-4-0	1-4-0	1-4-0	1-4-0	1-4-0	1-4-0	1-4-0	1-4-0	1-3-8

Plate Offsets (X,Y)-- [6:0-1-8,Edge], [24:0-1-8,Edge], [36:0-1-8,Edge], [52:0-1-8,Edge]

LOADING (psf)	SPACING-	2-0-0	CSI.	DEFL.	in (loc)	l/defl	L/d	PLATES	GRIP
TCLL 40.0	Plate Grip DOL	1.00	TC 0.06	Vert(LL)	n/a	-	n/a	MT20	244/190
TCDL 10.0	Lumber DOL	1.00	BC 0.01	Vert(CT)	n/a	-	n/a		
BCLL 0.0	Rep Stress Incr	YES	WB 0.03	Horz(CT)	-0.00	36	n/a		
BCDL 5.0	Code IRC2015/TPI2014		Matrix-S						
								Weight: 146 lb	FT = 20%F, 11%E

LUMBER-	BRACING-
TOP CHORD 2x4 SP No.1(flat)	TOP CHORD Structural wood sheathing directly applied or 6-0-0 oc purlins, except end verticals.
BOT CHORD 2x4 SP No.1(flat)	BOT CHORD Rigid ceiling directly applied or 6-0-0 oc bracing.
WEBS 2x4 SP No.3(flat)	
OTHERS 2x4 SP No.3(flat)	

REACTIONS. All bearings 34-7-8.
(lb) - Max Grav All reactions 250 lb or less at joint(s) 58, 30, 57, 56, 55, 54, 53, 52, 51, 50, 48, 47, 46, 45, 44, 43, 42, 40, 39, 38, 37, 36, 35, 34, 33, 32, 31

FORCES. (lb) - Max. Comp./Max. Ten. - All forces 250 (lb) or less except when shown.

- NOTES-**
- 1) All plates are 1.5x3 MT20 unless otherwise indicated.
 - 2) Plates checked for a plus or minus 1 degree rotation about its center.
 - 3) Gable requires continuous bottom chord bearing.
 - 4) Truss to be fully sheathed from one face or securely braced against lateral movement (i.e. diagonal web).
 - 5) Gable studs spaced at 1-4-0 oc.
 - 6) Recommend 2x6 strongbacks, on edge, spaced at 10-0-0 oc and fastened to each truss with 3-10d (0.131" X 3") nails. Strongbacks to be attached to walls at their outer ends or restrained by other means.

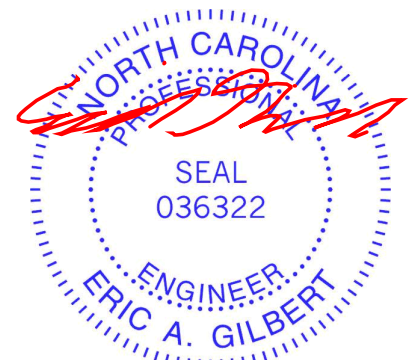

April 20,2023

Job J0623-2993	Truss F1	Truss Type Floor	Qty 1	Ply 1	Lot 2 West Pointe III Job Reference (optional)	157899248
-------------------	-------------	---------------------	----------	----------	---	-----------

Comtech, Inc. Fayetteville, NC - 28314,

8.430 s Jan 6 2022 MiTek Industries, Inc. Thu Apr 20 14:52:31 2023 Page 1

ID:uB1kUybQLa2UVI5EAk1M8Myf?Wk-RfC?PsB70Hq3NSgPqnL8w3uITXbGKWrCDoi7J4zJC?f

0-1-8



Scale = 1:23.7

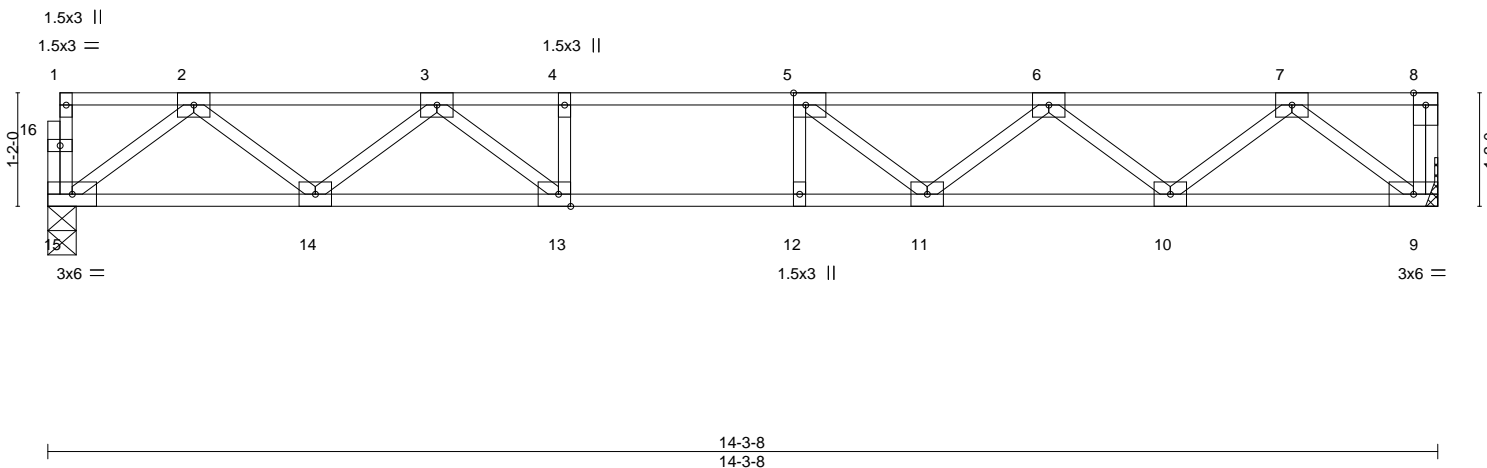

Plate Offsets (X,Y)--	[5:0-1-8,Edge], [13:0-1-8,Edge]				
LOADING (psf)	SPACING- 2-0-0	CSI.	DEFL. in (loc) l/defl L/d	PLATES	GRIP
TCLL 40.0	Plate Grip DOL 1.00	TC 0.59	Vert(LL) -0.18 11-12 >925 480	MT20	244/190
TCDL 10.0	Lumber DOL 1.00	BC 0.86	Vert(CT) -0.24 11-12 >700 360		
BCLL 0.0	Rep Stress Incr YES	WB 0.38	Horz(CT) 0.04 9 n/a n/a		
BCDL 5.0	Code IRC2015/TPI2014	Matrix-S			
				Weight: 71 lb	FT = 20%F, 11%E

LUMBER-
TOP CHORD 2x4 SP No.1(flat)
BOT CHORD 2x4 SP No.1(flat)
WEBS 2x4 SP No.3(flat)

BRACING-
TOP CHORD Structural wood sheathing directly applied or 6-0-0 oc purlins, except end verticals.
BOT CHORD Rigid ceiling directly applied or 10-0-0 oc bracing.

REACTIONS. (size) 15=0-3-8, 9=Mechanical
Max Grav 15=766(LC 1), 9=772(LC 1)

FORCES. (lb) - Max. Comp./Max. Ten. - All forces 250 (lb) or less except when shown.
TOP CHORD 2-3=-1532/0, 3-4=-2536/0, 4-5=-2536/0, 5-6=-2373/0, 6-7=-1553/0
BOT CHORD 14-15=0/951, 13-14=0/2110, 12-13=0/2536, 11-12=0/2536, 10-11=0/2135, 9-10=0/944
WEBS 2-15=-1190/0, 2-14=0/757, 3-14=-752/0, 3-13=0/731, 7-9=-1184/0, 7-10=0/793,
6-10=-757/0, 6-11=0/394, 5-11=-432/20, 4-13=-312/0

- NOTES-**
- 1) Unbalanced floor live loads have been considered for this design.
 - 2) All plates are 3x4 MT20 unless otherwise indicated.
 - 3) Plates checked for a plus or minus 1 degree rotation about its center.
 - 4) Refer to girder(s) for truss to truss connections.
 - 5) Recommend 2x6 strongbacks, on edge, spaced at 10-0-0 oc and fastened to each truss with 3-10d (0.131" X 3") nails. Strongbacks to be attached to walls at their outer ends or restrained by other means.
 - 6) CAUTION, Do not erect truss backwards.



April 20, 2023

WARNING - Verify design parameters and READ NOTES ON THIS AND INCLUDED MITEK REFERENCE PAGE MII-7473 rev. 1/2/2023 BEFORE USE.
Design valid for use only with MiTek® connectors. This design is based only upon parameters shown, and is for an individual building component, not a truss system. Before use, the building designer must verify the applicability of design parameters and properly incorporate this design into the overall building design. Bracing indicated is to prevent buckling of individual truss web and/or chord members only. Additional temporary and permanent bracing is always required for stability and to prevent collapse with possible personal injury and property damage. For general guidance regarding the fabrication, storage, delivery, erection and bracing of trusses and truss systems, see **ANSI/TP1 Quality Criteria and DSB-22** available from Truss Plate Institute (www.tpinst.org) and **BCSI Building Component Safety Information** available from the Structural Building Component Association (www.sbcacomponents.com)



818 Soundside Road
Edenton, NC 27932

Job J0623-2993	Truss F2	Truss Type Floor	Qty 3	Ply 1	Lot 2 West Pointe III I57899249
-------------------	-------------	---------------------	----------	----------	------------------------------------

Comtech, Inc. Fayetteville, NC - 28314,

8.430 s Jan 6 2022 MiTek Industries, Inc. Thu Apr 20 14:52:33 2023 Page 1

ID:uB1kUybQLa2UVI5EAk1M8Myf?Wk-RfC?PsB70Hq3NSgPqnL8w3uITXbGKWrcD0i7J4zJC?f

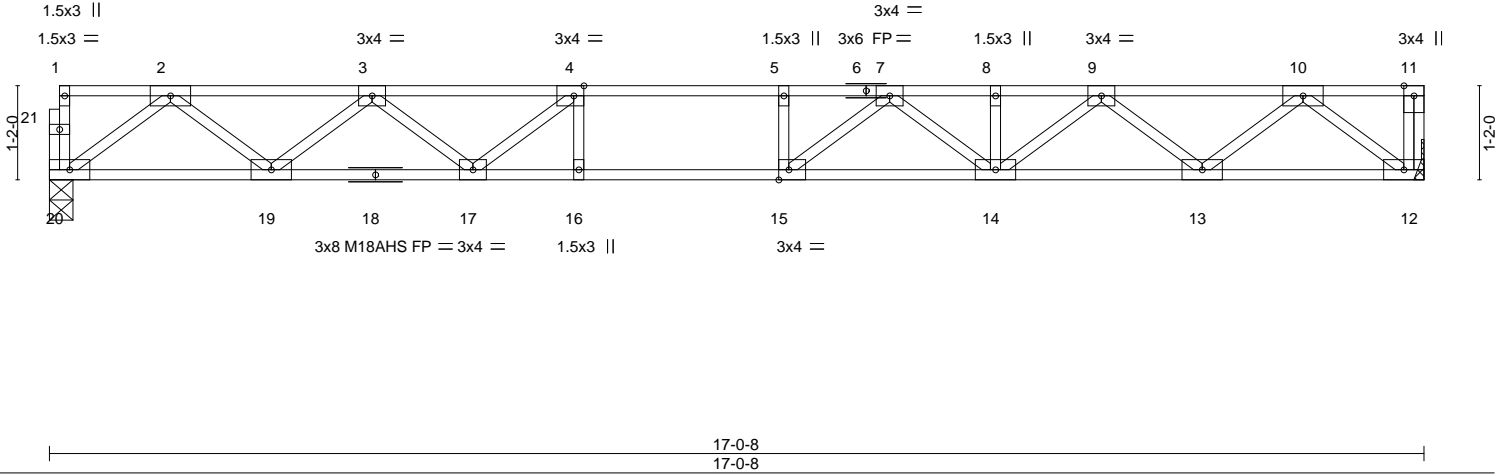
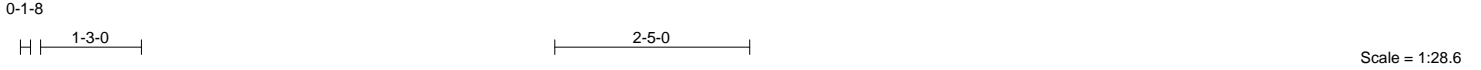

Plate Offsets (X,Y)--	[4:0-1-8,Edge], [15:0-1-8,Edge]				
LOADING (psf)	SPACING- 2-0-0	CSI.	DEFL. in (loc) l/defl L/d	PLATES	GRIP
TCLL 40.0	Plate Grip DOL 1.00	TC 0.82	Vert(LL) -0.28 14-15 >728 480	MT20	244/190
TCDL 10.0	Lumber DOL 1.00	BC 0.66	Vert(CT) -0.37 14-15 >542 360	M18AHS	186/179
BCLL 0.0	Rep Stress Incr YES	WB 0.48	Horz(CT) 0.05 12 n/a n/a		
BCDL 5.0	Code IRC2015/TPI2014	Matrix-S		Weight: 85 lb	FT = 20%F, 11%E

LUMBER-	BRACING-
TOP CHORD 2x4 SP No.1(flat)	TOP CHORD Structural wood sheathing directly applied or 2-2-0 oc purlins, except end verticals.
BOT CHORD 2x4 SP 2400F 2.0E(flat)	BOT CHORD Rigid ceiling directly applied or 10-0-0 oc bracing.
WEBS 2x4 SP No.3(flat)	

REACTIONS. (size) 20=0-3-8, 12=Mechanical
Max Grav 20=917(LC 1), 12=924(LC 1)

FORCES. (lb) - Max. Comp./Max. Ten. - All forces 250 (lb) or less except when shown.
 TOP CHORD 2-3=-1929/0, 3-4=-3122/0, 4-5=-3644/0, 5-7=-3644/0, 7-8=-3180/0, 8-9=-3180/0, 9-10=-1924/0
 BOT CHORD 19-20=0/1150, 17-19=0/2667, 16-17=0/3644, 15-16=0/3644, 14-15=0/3518, 13-14=0/2673, 12-13=0/1149
 WEBS 2-20=-1440/0, 2-19=0/1014, 3-19=-960/0, 3-17=0/636, 10-12=-1442/0, 10-13=0/1009, 9-13=-975/0, 9-14=0/648, 7-14=-431/0, 7-15=-144/537, 4-17=-845/0

- NOTES-**
- 1) Unbalanced floor live loads have been considered for this design.
 - 2) All plates are MT20 plates unless otherwise indicated.
 - 3) All plates are 3x6 MT20 unless otherwise indicated.
 - 4) Plates checked for a plus or minus 1 degree rotation about its center.
 - 5) Refer to girder(s) for truss to truss connections.
 - 6) Recommend 2x6 strongbacks, on edge, spaced at 10-0-0 oc and fastened to each truss with 3-10d (0.131" X 3") nails. Strongbacks to be attached to walls at their outer ends or restrained by other means.
 - 7) CAUTION, Do not erect truss backwards.



Job	Truss	Truss Type	Qty	Ply	Lot 2 West Pointe III	157899250
J0623-2993	F2A	Floor	1	1	Job Reference (optional)	

Comtech, Inc. Fayetteville, NC - 28314,

8.430 s Jan 6 2022 MiTek Industries, Inc. Thu Apr 20 14:52:34 2023 Page 1

ID:uB1kUybQLa2UVI5EAk1M8Myf?Wk-RfC?PsB70Hq3NSgPqnL8w3uITXbGKWrCDoi7J4zJC?f

0-1-8



Scale = 1:28.4

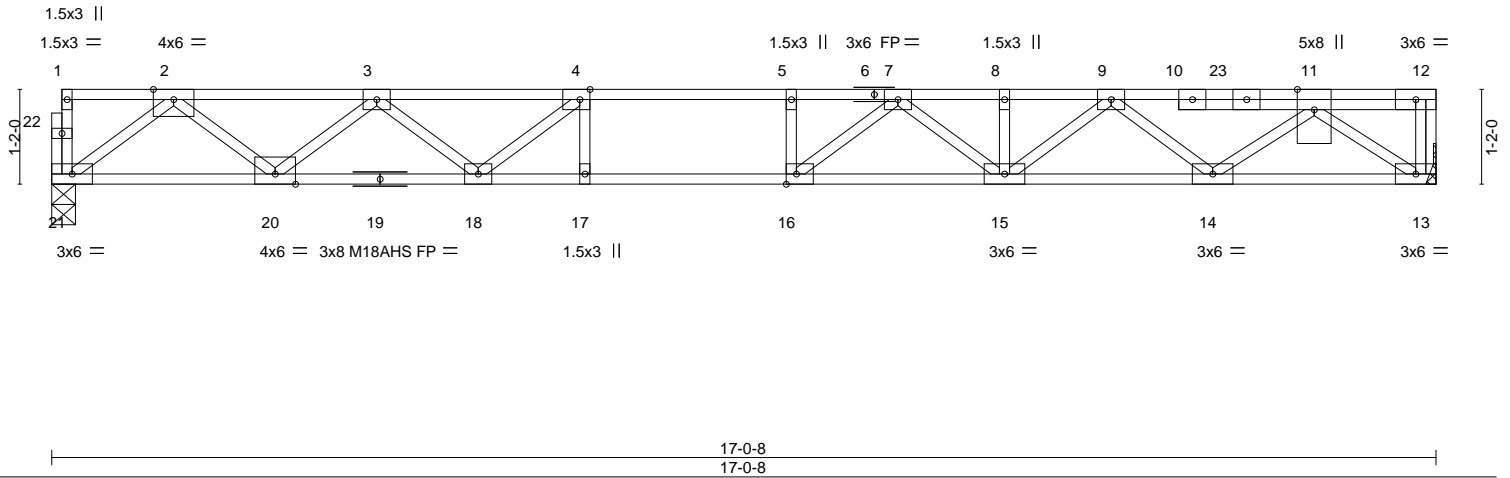

Plate Offsets (X,Y)--	[4:0-1-8,Edge], [16:0-1-8,Edge]								
LOADING (psf)	SPACING-	2-0-0	CSI.	DEFL.	in (loc)	l/defl	L/d	PLATES	GRIP
TCLL 40.0	Plate Grip DOL 1.00		TC 0.72	Vert(LL) -0.31	15-16	>648	480	MT20	244/190
TCDL 10.0	Lumber DOL 1.00		BC 0.87	Vert(CT) -0.42	15-16	>480	360	M18AHS	186/179
BCLL 0.0	Rep Stress Incr NO		WB 0.53	Horz(CT) 0.06	13	n/a	n/a		
BCDL 5.0	Code IRC2015/TPI2014		Matrix-S						
								Weight: 89 lb	FT = 20%F, 11%E

LUMBER-		BRACING-	
TOP CHORD	2x4 SP 2400F 2.0E(flat)	TOP CHORD	Structural wood sheathing directly applied or 6-0-0 oc purlins, except end verticals.
BOT CHORD	2x4 SP 2400F 2.0E(flat)	BOT CHORD	Rigid ceiling directly applied or 10-0-0 oc bracing.
WEBS	2x4 SP No.3(flat)		

REACTIONS. (size) 21=0-3-8, 13=Mechanical
Max Grav 21=980(LC 1), 13=1283(LC 1)

FORCES. (lb) - Max. Comp./Max. Ten. - All forces 250 (lb) or less except when shown.
TOP CHORD 2-3=-2085/0, 3-4=-3437/0, 4-5=-4106/0, 5-7=-4106/0, 7-8=-3878/0, 8-9=-3878/0, 9-11=-2689/0
BOT CHORD 20-21=0/1237, 18-20=0/2887, 17-18=0/4106, 16-17=0/4106, 15-16=0/4136, 14-15=0/3474, 13-14=0/1802
WEBS 2-21=-1549/0, 2-20=0/1104, 3-20=-1044/0, 3-18=0/767, 11-13=-2212/0, 11-14=0/1108, 9-14=-1041/0, 9-15=0/515, 7-15=-395/0, 7-16=-352/490, 4-18=-1025/0, 4-17=-50/286

- NOTES-**
- 1) Unbalanced floor live loads have been considered for this design.
 - 2) All plates are MT20 plates unless otherwise indicated.
 - 3) All plates are 3x4 MT20 unless otherwise indicated.
 - 4) Plates checked for a plus or minus 1 degree rotation about its center.
 - 5) Refer to girder(s) for truss to truss connections.
 - 6) Recommend 2x6 strongbacks, on edge, spaced at 10-0-0 oc and fastened to each truss with 3-10d (0.131" X 3") nails. Strongbacks to be attached to walls at their outer ends or restrained by other means.
 - 7) CAUTION, Do not erect truss backwards.
 - 8) Hanger(s) or other connection device(s) shall be provided sufficient to support concentrated load(s) 422 lb down at 14-5-0 on top chord. The design/selection of such connection device(s) is the responsibility of others.
 - 9) In the LOAD CASE(S) section, loads applied to the face of the truss are noted as front (F) or back (B).

LOAD CASE(S) Standard
1) Dead + Floor Live (balanced): Lumber Increase=1.00, Plate Increase=1.00
Uniform Loads (plf)
Vert: 13-21=-10, 1-12=-100
Concentrated Loads (lb)
Vert: 23=-422(F)

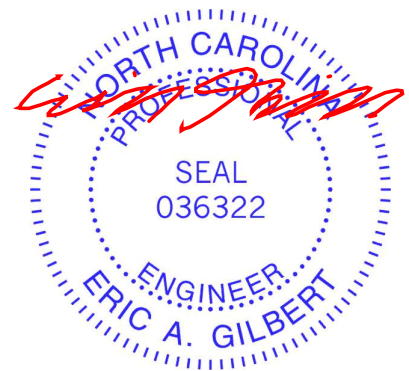

Job J0623-2993	Truss F3	Truss Type Floor	Qty 1	Ply 1	Lot 2 West Pointe III Job Reference (optional)	157899251
-------------------	-------------	---------------------	----------	----------	---	-----------

Comtech, Inc. Fayetteville, NC - 28314,

8.430 s Jan 6 2022 MiTek Industries, Inc. Thu Apr 20 14:52:35 2023 Page 1

ID:uB1kUybQLa2UVI5EAk1M8Myf?Wk-RfC?PsB70Hq3NSgPqnL8w3uITXbGKWrcD0i7J4zJC?f

1-3-0

2-4-8

0-1-8

Scale = 1:17.2

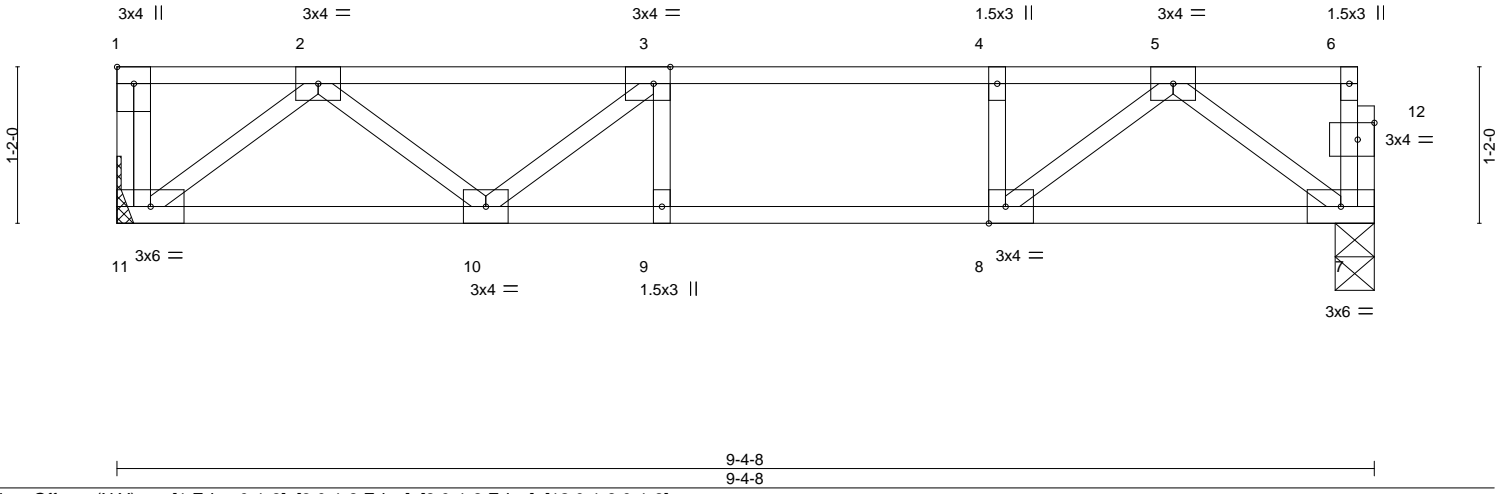

Plate Offsets (X,Y)--	[1:Edge,0-1-8], [3:0-1-8,Edge], [8:0-1-8,Edge], [12:0-1-8,0-1-8]				
LOADING (psf)	SPACING- 2-0-0	CSI.	DEFL. in (loc) l/defl L/d	PLATES	GRIP
TCLL 40.0	Plate Grip DOL 1.00	TC 0.47	Vert(LL) -0.09 9 >999 480	MT20	244/190
TCDL 10.0	Lumber DOL 1.00	BC 0.53	Vert(CT) -0.11 9 >998 360		
BCLL 0.0	Rep Stress Incr YES	WB 0.30	Horz(CT) 0.01 7 n/a n/a		
BCDL 5.0	Code IRC2015/TPI2014	Matrix-S		Weight: 47 lb	FT = 20%F, 11%E

LUMBER-	BRACING-
TOP CHORD 2x4 SP No.1(flat)	TOP CHORD Structural wood sheathing directly applied or 6-0-0 oc purlins, except end verticals.
BOT CHORD 2x4 SP No.1(flat)	BOT CHORD Rigid ceiling directly applied or 10-0-0 oc bracing.
WEBS 2x4 SP No.3(flat)	

REACTIONS. (size) 11=Mechanical, 7=0-3-8
Max Grav 11=502(LC 1), 7=496(LC 1)

FORCES. (lb) - Max. Comp./Max. Ten. - All forces 250 (lb) or less except when shown.
TOP CHORD 2-3=-865/0, 3-4=-1039/0, 4-5=-1039/0
BOT CHORD 10-11=0/612, 9-10=0/1039, 8-9=0/1039, 7-8=0/573
WEBS 2-11=-768/0, 2-10=0/330, 5-7=-714/0, 5-8=0/623, 4-8=-289/0, 3-10=-294/0

- NOTES-**
- 1) Unbalanced floor live loads have been considered for this design.
 - 2) Plates checked for a plus or minus 1 degree rotation about its center.
 - 3) Refer to girder(s) for truss to truss connections.
 - 4) Recommend 2x6 strongbacks, on edge, spaced at 10-0-0 oc and fastened to each truss with 3-10d (0.131" X 3") nails. Strongbacks to be attached to walls at their outer ends or restrained by other means.
 - 5) CAUTION, Do not erect truss backwards.

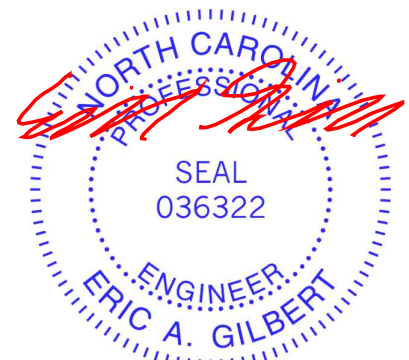

April 20, 2023

<p>WARNING - Verify design parameters and READ NOTES ON THIS AND INCLUDED MITEK REFERENCE PAGE MII-7473 rev. 1/2/2023 BEFORE USE.</p> <p>Design valid for use only with MiTek® connectors. This design is based only upon parameters shown, and is for an individual building component, not a truss system. Before use, the building designer must verify the applicability of design parameters and properly incorporate this design into the overall building design. Bracing indicated is to prevent buckling of individual truss web and/or chord members only. Additional temporary and permanent bracing is always required for stability and to prevent collapse with possible personal injury and property damage. For general guidance regarding the fabrication, storage, delivery, erection and bracing of trusses and truss systems, see ANSI/TP1 Quality Criteria and DSB-22 available from Truss Plate Institute (www.tpinst.org) and BCSI Building Component Safety Information available from the Structural Building Component Association (www.sbcacomponents.com)</p>	<p>ENGINEERING BY</p> <p>TRENCO</p> <p>A MiTek Affiliate</p> <p>818 Soundside Road Edenton, NC 27932</p>
--	---

Job J0623-2993	Truss F4	Truss Type Floor	Qty 3	Ply 1	Lot 2 West Pointe III Job Reference (optional)	157899252
-------------------	-------------	---------------------	----------	----------	---	-----------

Comtech, Inc. Fayetteville, NC - 28314,

8.430 s Jan 6 2022 MiTek Industries, Inc. Thu Apr 20 14:52:36 2023 Page 1

ID:uB1kUybQLa2UVI5EAk1M8Myf?Wk-RfC?PsB70Hq3NSgPqnL8w3uITXbGKWrCDoi7J4zJC?f

1-3-0

1-7-0

0-1-8

Scale = 1:29.5

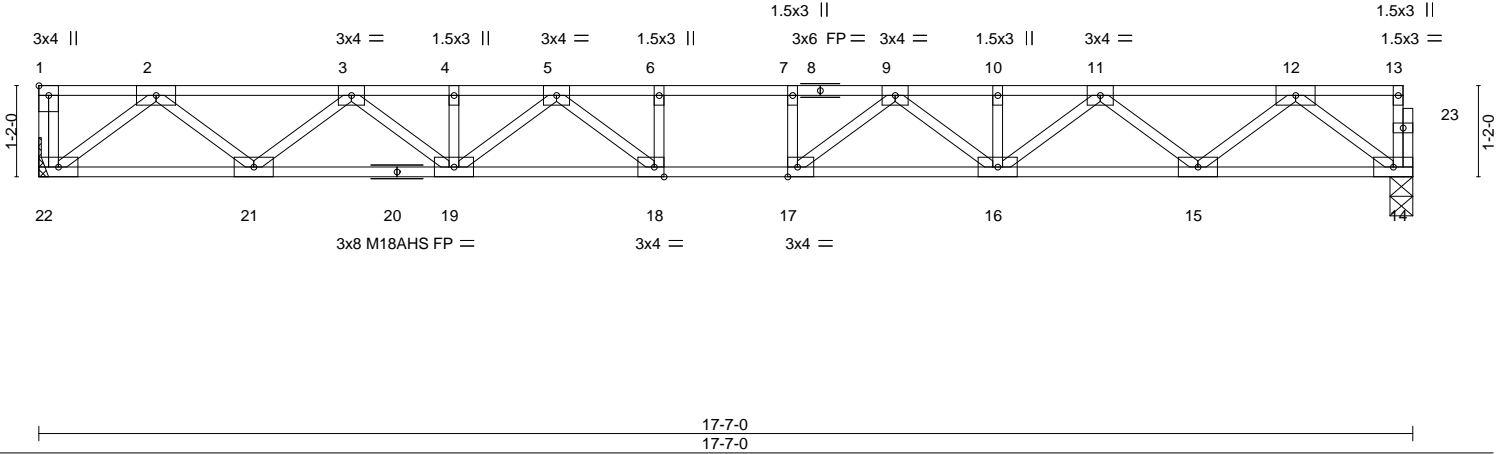

Plate Offsets (X,Y)-- [1:Edge,0-1-8], [17:0-1-8,Edge], [18:0-1-8,Edge]

LOADING (psf)	SPACING-	2-0-0	CSI.	DEFL.	in (loc)	l/defl	L/d	PLATES	GRIP
TCLL 40.0	Plate Grip DOL	1.00	TC 0.44	Vert(LL)	-0.27	17-18	>782	MT20	244/190
TCDL 10.0	Lumber DOL	1.00	BC 0.75	Vert(CT)	-0.37	17-18	>569	M18AHS	186/179
BCLL 0.0	Rep Stress Incr	YES	WB 0.50	Horz(CT)	0.07	14	n/a		
BCDL 5.0	Code IRC2015/TPI2014		Matrix-S						
								Weight: 90 lb	FT = 20%F, 11%E

LUMBER-	BRACING-
TOP CHORD 2x4 SP No.1(flat)	TOP CHORD Structural wood sheathing directly applied or 6-0-0 oc purlins, except end verticals.
BOT CHORD 2x4 SP No.1(flat)	BOT CHORD Rigid ceiling directly applied or 10-0-0 oc bracing.
WEBS 2x4 SP No.3(flat)	

REACTIONS. (size) 22=Mechanical, 14=0-3-8
Max Grav 22=953(LC 1), 14=947(LC 1)

FORCES. (lb) - Max. Comp./Max. Ten. - All forces 250 (lb) or less except when shown.

TOP CHORD 2-3=-2001/0, 3-4=-3321/0, 4-5=-3321/0, 5-6=-3931/0, 6-7=-3931/0, 7-9=-3931/0, 9-10=-3321/0, 10-11=-3321/0, 11-12=-2001/0

BOT CHORD 21-22=0/1190, 19-21=0/2779, 18-19=0/3710, 17-18=0/3710, 15-16=0/2779, 14-15=0/1189

WEBS 2-22=-1493/0, 2-21=0/1056, 3-21=-1012/0, 3-19=0/693, 12-14=-1489/0, 12-15=0/1057, 11-15=-1013/0, 11-16=0/693, 5-19=-496/0, 9-16=-496/0, 9-17=-93/587, 5-18=-93/587, 6-18=-265/0, 7-17=-265/0

- NOTES-**
- 1) Unbalanced floor live loads have been considered for this design.
 - 2) All plates are MT20 plates unless otherwise indicated.
 - 3) All plates are 3x6 MT20 unless otherwise indicated.
 - 4) Plates checked for a plus or minus 1 degree rotation about its center.
 - 5) Refer to girder(s) for truss to truss connections.
 - 6) Recommend 2x6 strongbacks, on edge, spaced at 10-0-0 oc and fastened to each truss with 3-10d (0.131" X 3") nails. Strongbacks to be attached to walls at their outer ends or restrained by other means.
 - 7) CAUTION, Do not erect truss backwards.

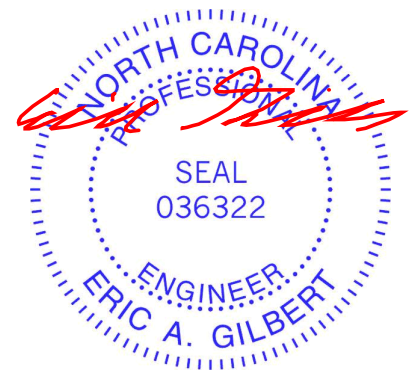

<p>WARNING - Verify design parameters and READ NOTES ON THIS AND INCLUDED MITEK REFERENCE PAGE MII-7473 rev. 1/2/2023 BEFORE USE.</p> <p>Design valid for use only with MiTek® connectors. This design is based only upon parameters shown, and is for an individual building component, not a truss system. Before use, the building designer must verify the applicability of design parameters and properly incorporate this design into the overall building design. Bracing indicated is to prevent buckling of individual truss web and/or chord members only. Additional temporary and permanent bracing is always required for stability and to prevent collapse with possible personal injury and property damage. For general guidance regarding the fabrication, storage, delivery, erection and bracing of trusses and truss systems, see ANSI/TPH Quality Criteria and DSB-22 available from Truss Plate Institute (www.tpinst.org) and BCSI Building Component Safety Information available from the Structural Building Component Association (www.sbcacomponents.com)</p>	<p>ENGINEERING BY TRENCO A MiTek Affiliate</p> <p>818 Soundside Road Edenton, NC 27932</p>
--	---

Job J0623-2993	Truss F4A	Truss Type Floor	Qty 1	Ply 1	Lot 2 West Pointe III Job Reference (optional)	157899253
-------------------	--------------	---------------------	----------	----------	---	-----------

Comtech, Inc. Fayetteville, NC - 28314,

8.430 s Jan 6 2022 MiTek Industries, Inc. Thu Apr 20 14:52:37 2023 Page 1

ID:uB1kUybQLa2UVI5EAk1M8Myf?Wk-RfC?PsB70Hq3NSgPqnL8w3uITXbGKWrcD0i7J4zJC?f

1-3-0

1-7-0

0-1-8

Scale = 1:29.5

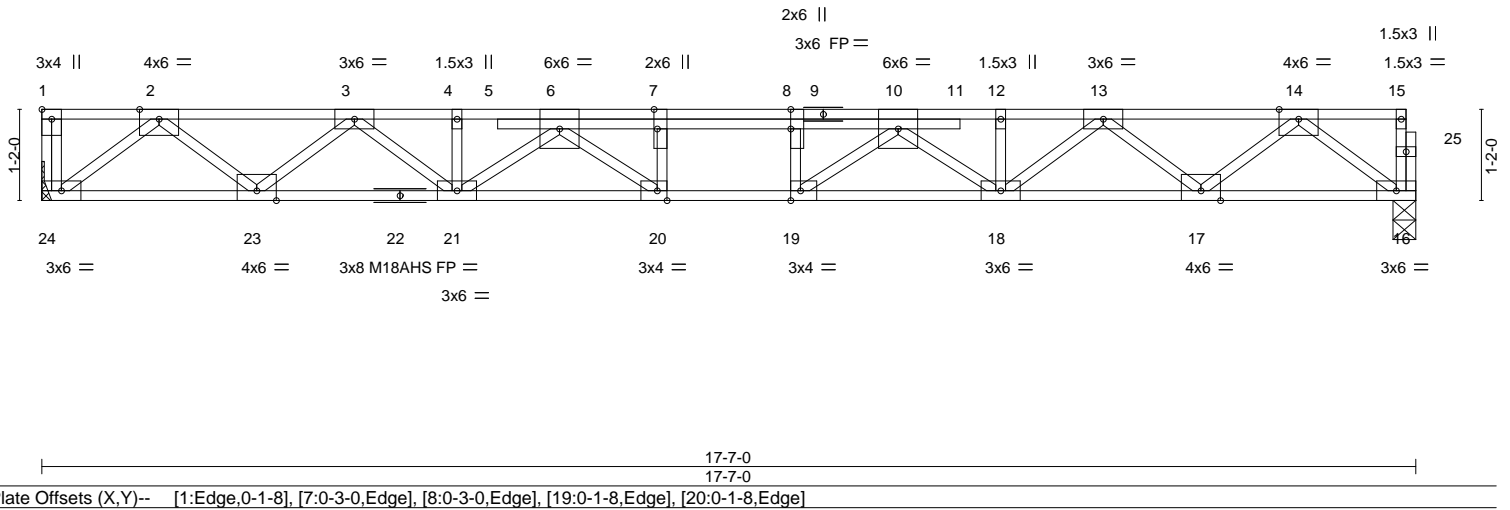

LOADING (psf)	SPACING-	2-0-0	CSI.	DEFL.	in (loc)	l/defl	L/d	PLATES	GRIP
TCLL 40.0	Plate Grip DOL	1.00	TC 0.41	Vert(LL)	-0.27	20	>768	MT20	244/190
TCDL 10.0	Lumber DOL	1.00	BC 0.60	Vert(CT)	-0.37	20	>559	M18AHS	186/179
BCLL 0.0	Rep Stress Incr	NO	WB 0.62	Horz(CT)	0.07	16	n/a		
BCDL 5.0	Code IRC2015/TPI2014		Matrix-S						
								Weight: 98 lb	FT = 20%F, 11%E

LUMBER-	BRACING-
TOP CHORD 2x4 SP No.1(flat)	TOP CHORD Structural wood sheathing directly applied or 6-0-0 oc purlins, except end verticals.
BOT CHORD 2x4 SP 2400F 2.0E(flat)	BOT CHORD Rigid ceiling directly applied or 10-0-0 oc bracing.
WEBS 2x4 SP No.3(flat)	

REACTIONS. (size) 24=Mechanical, 16=0-3-8
Max Grav 24=1107(LC 1), 16=1073(LC 1)

FORCES. (lb) - Max. Comp./Max. Ten. - All forces 250 (lb) or less except when shown.
 TOP CHORD 2-3=-2387/0, 3-4=-4067/0, 4-6=-4072/0, 6-7=-5269/0, 7-8=-5269/0, 8-10=-5269/0, 10-12=-3931/0, 12-13=-3928/0, 13-14=-2319/0
 BOT CHORD 23-24=0/1390, 21-23=0/3354, 20-21=0/4881, 19-20=0/5269, 18-19=0/4677, 17-18=0/3248, 16-17=0/1354
 WEBS 2-24=-1744/0, 2-23=0/1298, 3-23=-1259/0, 3-21=0/911, 14-16=-1696/0, 14-17=0/1256, 13-17=-1209/0, 13-18=0/869, 6-21=-1016/0, 10-18=-935/0, 10-19=0/1037, 6-20=0/782, 7-20=-442/0, 8-19=-542/0

- NOTES-**
- 1) Unbalanced floor live loads have been considered for this design.
 - 2) All plates are MT20 plates unless otherwise indicated.
 - 3) Plates checked for a plus or minus 1 degree rotation about its center.
 - 4) Refer to girder(s) for truss to truss connections.
 - 5) Recommend 2x6 strongbacks, on edge, spaced at 10-0-0 oc and fastened to each truss with 3-10d (0.131" X 3") nails. Strongbacks to be attached to walls at their outer ends or restrained by other means.
 - 6) CAUTION, Do not erect truss backwards.
 - 7) Hanger(s) or other connection device(s) shall be provided sufficient to support concentrated load(s) 280 lb down at 8-1-0 on top chord. The design/selection of such connection device(s) is the responsibility of others.
 - 8) In the LOAD CASE(S) section, loads applied to the face of the truss are noted as front (F) or back (B).

LOAD CASE(S) Standard
 1) Dead + Floor Live (balanced): Lumber Increase=1.00, Plate Increase=1.00
 Uniform Loads (plf)
 Vert: 16-24=-10, 1-15=-100
 Concentrated Loads (lb)
 Vert: 7=-280(F)

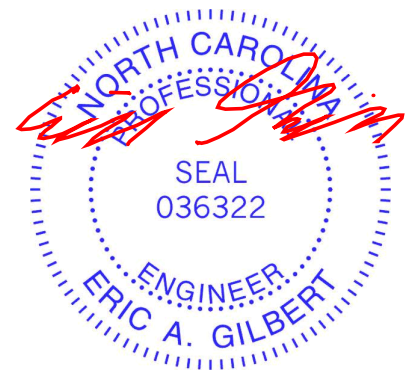

April 20, 2023

Job	Truss	Truss Type	Qty	Ply	Lot 2 West Pointe III	I57899254
J0623-2993	F5	Floor	1	1		
					Job Reference (optional)	

Comtech, Inc. Fayetteville, NC - 28314,

8.430 s Jan 6 2022 MiTek Industries, Inc. Thu Apr 20 14:52:39 2023 Page 1
ID:uB1kUybQLa2UVI5EAk1M8Myf?Wk-RfC?PsB70Hq3NSgPqnL8w3uITXbGKWrcDoi7J4zJC?f

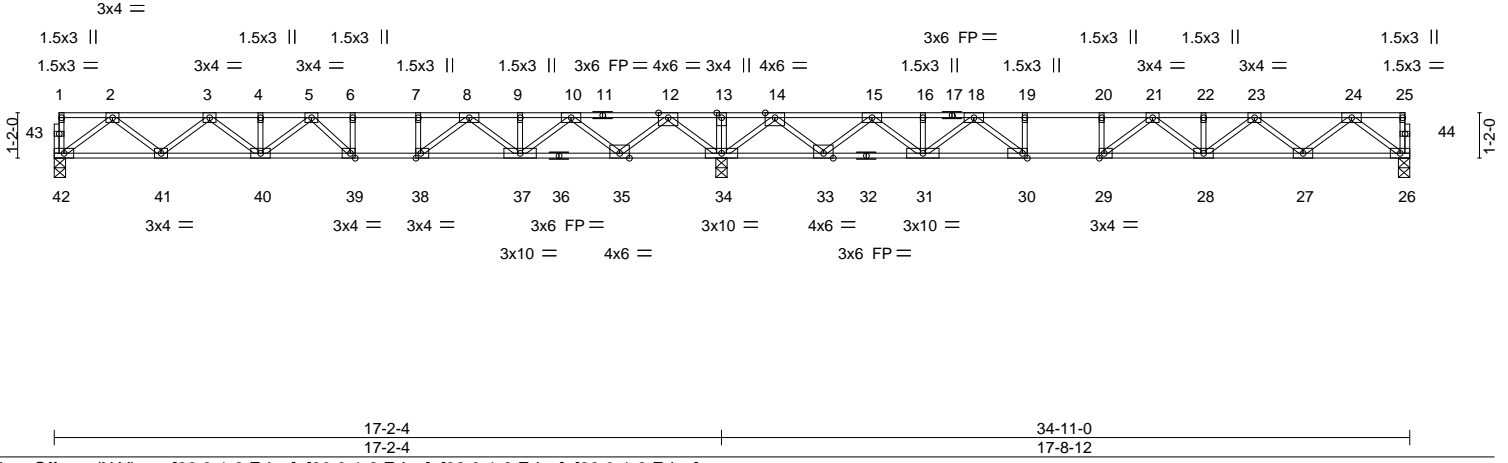

Plate Offsets (X, Y)--	[29:0-1-8,Edge], [30:0-1-8,Edge], [38:0-1-8,Edge], [39:0-1-8,Edge]				
LOADING (psf)	SPACING- 2-0-0	CSI.	DEFL. in (loc) l/defl L/d	PLATES	GRIP
TCLL 40.0	Plate Grip DOL 1.00	TC 0.83	Vert(LL) -0.23 28-29 >932 480	MT20	244/190
TCDL 10.0	Lumber DOL 1.00	BC 0.59	Vert(CT) -0.31 28-29 >692 360		
BCLL 0.0	Rep Stress Incr YES	WB 0.66	Horz(CT) 0.04 26 n/a n/a		
BCDL 5.0	Code IRC2015/TPI2014	Matrix-S		Weight: 177 lb	FT = 20%F, 11%E

LUMBER-	BRACING-
TOP CHORD 2x4 SP No.1(flat)	TOP CHORD Structural wood sheathing directly applied or 6-0-0 oc purlins, except end verticals.
BOT CHORD 2x4 SP 2400F 2.0E(flat)	BOT CHORD Rigid ceiling directly applied or 6-0-0 oc bracing.
WEBS 2x4 SP No.3(flat)	

REACTIONS. (size) 42=0-3-8, 34=0-3-8, 26=0-3-8
Max Grav 42=807(LC 3), 34=2305(LC 1), 26=834(LC 4)

FORCES. (lb) - Max. Comp./Max. Ten. - All forces 250 (lb) or less except when shown.

TOP CHORD 2-3=-1647/0, 3-4=-2631/0, 4-5=-2631/0, 5-6=-2796/21, 6-7=-2796/21, 7-8=-2796/21, 8-9=-1816/613, 9-10=-1816/613, 10-12=-232/1275, 12-13=0/3262, 13-14=0/3262, 14-15=-211/1178, 15-16=-1870/522, 16-18=-1870/522, 18-19=-2974/0, 19-20=-2974/0, 20-21=-2974/0, 21-22=-2771/0, 22-23=-2771/0, 23-24=-1715/0

BOT CHORD 41-42=0/1003, 40-41=0/2263, 39-40=0/2832, 38-39=-21/2796, 37-38=-344/2354, 35-37=-927/1138, 34-35=-1856/0, 33-34=-1824/0, 31-33=-833/1153, 30-31=-254/2451, 29-30=0/2974, 28-29=0/3006, 27-28=0/2367, 26-27=0/1039

WEBS 2-42=-1256/0, 2-41=0/837, 3-41=-803/0, 3-40=-15/469, 12-34=-1765/0, 12-35=0/1342, 10-35=-1295/0, 10-37=0/986, 8-37=-816/0, 8-38=0/953, 5-40=-256/109, 5-39=-491/92, 7-38=-393/0, 24-26=-1300/0, 24-27=0/880, 23-27=-850/0, 23-28=0/515, 14-34=-1805/0, 14-33=0/1379, 15-33=-1328/0, 15-31=0/1023, 18-31=-858/0, 18-30=0/1043, 21-28=-301/77, 21-29=-485/127, 19-30=-434/0

- NOTES-**
- 1) Unbalanced floor live loads have been considered for this design.
 - 2) All plates are 3x6 MT20 unless otherwise indicated.
 - 3) Plates checked for a plus or minus 1 degree rotation about its center.
 - 4) Recommend 2x6 strongbacks, on edge, spaced at 10-0-0 oc and fastened to each truss with 3-10d (0.131" X 3") nails. Strongbacks to be attached to walls at their outer ends or restrained by other means.
 - 5) CAUTION, Do not erect truss backwards.



<p>WARNING - Verify design parameters and READ NOTES ON THIS AND INCLUDED MITEK REFERENCE PAGE MII-7473 rev. 1/2/2023 BEFORE USE.</p> <p>Design valid for use only with MiTek® connectors. This design is based only upon parameters shown, and is for an individual building component, not a truss system. Before use, the building designer must verify the applicability of design parameters and properly incorporate this design into the overall building design. Bracing indicated is to prevent buckling of individual truss web and/or chord members only. Additional temporary and permanent bracing is always required for stability and to prevent collapse with possible personal injury and property damage. For general guidance regarding the fabrication, storage, delivery, erection and bracing of trusses and truss systems, see ANSI/TPH Quality Criteria and DSB-22 available from Truss Plate Institute (www.tpinst.org) and BCSI Building Component Safety Information available from the Structural Building Component Association (www.sbcacomponents.com)</p>	<p>818 Soundside Road Edenton, NC 27932</p>
--	---

Job J0623-2993	Truss F6	Truss Type Floor	Qty 5	Ply 1	Lot 2 West Pointe III Job Reference (optional)	I57899255
-------------------	-------------	---------------------	----------	----------	---	-----------

Comtech, Inc. Fayetteville, NC - 28314,

8.430 s Jan 6 2022 MiTek Industries, Inc. Thu Apr 20 14:52:41 2023 Page 1
ID:uB1kUyQLa2UVI5EAk1M8Myf?Wk-RfC?PsB70Hq3NSgPqnL8w3uITXbGKWrcDoi7J4zJC?f

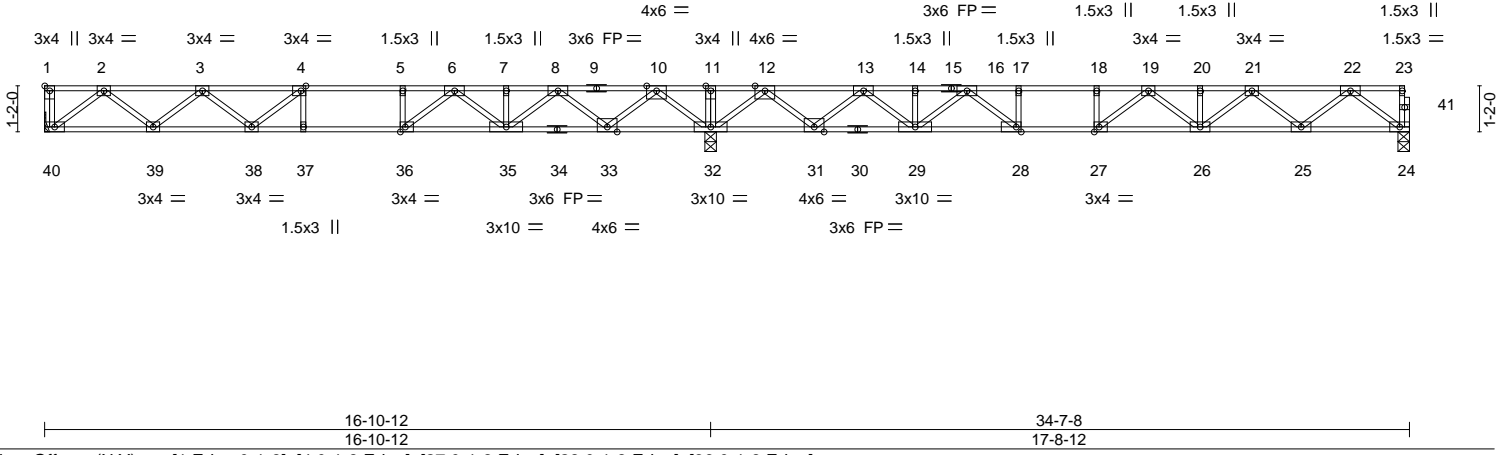

LOADING (psf)	SPACING-	2-0-0	CSI.	DEFL.	in (loc)	l/defl	L/d	PLATES	GRIP
TCLL 40.0	Plate Grip DOL	1.00	TC 0.81	Vert(LL)	-0.23 26-27	>924	480	MT20	244/190
TCDL 10.0	Lumber DOL	1.00	BC 0.66	Vert(CT)	-0.31 26-27	>685	360		
BCLL 0.0	Rep Stress Incr	YES	WB 0.65	Horz(CT)	0.04 24	n/a	n/a		
BCDL 5.0	Code IRC2015/TPI2014		Matrix-S						
								Weight: 173 lb	FT = 20%F, 11%E

LUMBER-
TOP CHORD 2x4 SP No.1(flat)
BOT CHORD 2x4 SP 2400F 2.0E(flat)
WEBS 2x4 SP No.3(flat)

BRACING-
TOP CHORD Structural wood sheathing directly applied or 6-0-0 oc purlins, except end verticals.
BOT CHORD Rigid ceiling directly applied or 6-0-0 oc bracing.

REACTIONS. (size) 40=Mechanical, 32=0-3-8, 24=0-3-8
Max Grav 40=801(LC 3), 32=2265(LC 1), 24=844(LC 4)

FORCES. (lb) - Max. Comp./Max. Ten. - All forces 250 (lb) or less except when shown.

TOP CHORD 2-3=-1625/0, 3-4=-2518/0, 4-5=-2744/0, 5-6=-2744/0, 6-7=-1822/510, 7-8=-1822/510, 8-10=-286/1136, 10-11=0/3044, 11-12=0/3044, 12-13=-355/1088, 13-14=-1990/447, 14-16=-1990/447, 16-17=-3058/0, 17-18=-3058/0, 18-19=-3058/0, 19-20=-2820/0, 20-21=-2820/0, 21-22=-1740/0

BOT CHORD 39-40=0/983, 38-39=0/2236, 37-38=0/2744, 36-37=0/2744, 35-36=-248/2331, 33-35=-806/1169, 32-33=-1802/0, 31-32=-1623/0, 29-31=-750/1286, 28-29=-187/2558, 27-28=0/3058, 26-27=0/3069, 25-26=0/2404, 24-25=0/1052

WEBS 2-40=-1234/0, 2-39=0/835, 3-39=-796/0, 3-38=-54/367, 10-32=-1723/0, 10-33=0/1302, 8-33=-1252/0, 8-35=0/943, 6-35=-779/0, 6-36=0/956, 5-36=-384/0, 4-38=-288/219, 12-32=-1784/0, 12-31=0/1359, 13-31=-1309/0, 13-29=0/1002, 16-29=-836/0, 16-28=0/1019, 17-28=-425/0, 22-24=-1317/0, 22-25=0/896, 21-25=-865/0, 21-26=0/531, 19-26=-318/66, 19-27=-460/160

- NOTES-**
- 1) Unbalanced floor live loads have been considered for this design.
 - 2) All plates are 3x6 MT20 unless otherwise indicated.
 - 3) Plates checked for a plus or minus 1 degree rotation about its center.
 - 4) Refer to girder(s) for truss to truss connections.
 - 5) Recommend 2x6 strongbacks, on edge, spaced at 10-0-0 oc and fastened to each truss with 3-10d (0.131" X 3") nails. Strongbacks to be attached to walls at their outer ends or restrained by other means.
 - 6) CAUTION, Do not erect truss backwards.



April 20, 2023

WARNING - Verify design parameters and READ NOTES ON THIS AND INCLUDED MITEK REFERENCE PAGE MII-7473 rev. 1/2/2023 BEFORE USE.

Design valid for use only with MiTek® connectors. This design is based only upon parameters shown, and is for an individual building component, not a truss system. Before use, the building designer must verify the applicability of design parameters and properly incorporate this design into the overall building design. Bracing indicated is to prevent buckling of individual truss web and/or chord members only. Additional temporary and permanent bracing is always required for stability and to prevent collapse with possible personal injury and property damage. For general guidance regarding the fabrication, storage, delivery, erection and bracing of trusses and truss systems, see **ANSI/TPH Quality Criteria and DSB-22** available from Truss Plate Institute (www.tpinst.org) and **BCSI Building Component Safety Information** available from the Structural Building Component Association (www.sbcacomponents.com)

818 Soundside Road
Edenton, NC 27932

Symbols

PLATE LOCATION AND ORIENTATION



Center plate on joint unless x, y offsets are indicated. Dimensions are in ft-in-sixteenths. Apply plates to both sides of truss and fully embed teeth.



For 4 x 2 orientation, locate plates 0- 1/16" from outside edge of truss.



This symbol indicates the required direction of slots in connector plates.

* Plate location details available in MITek software or upon request.

PLATE SIZE

4 X 4

The first dimension is the plate width measured perpendicular to slots. Second dimension is the length parallel to slots.

LATERAL BRACING LOCATION



Indicated by symbol shown and/or by text in the bracing section of the output. Use T or I bracing if indicated.

BEARING

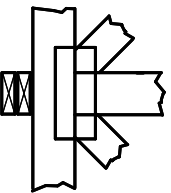

Indicates location where bearings (supports) occur. Icons vary but reaction section indicates joint number/letter where bearings occur. Min size shown is for crushing only.

Industry Standards:

ANSI/TP1: National Design Specification for Metal Plate Connected Wood Truss Construction.
DSB-22: Design Standard for Bracing.
BCSI: Building Component Safety Information, Guide to Good Practice for Handling, Installing, Restraining & Bracing of Metal Plate Connected Wood Trusses.

Numbering System



1 TOP CHORDS
2 JOINT ID TYP.

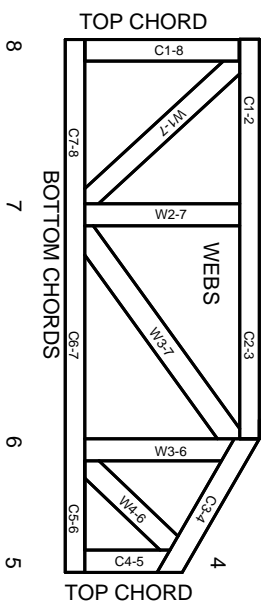

JOINTS ARE GENERALLY NUMBERED/LETTERED CLOCKWISE AROUND THE TRUSS STARTING AT THE JOINT FARTHEST TO THE LEFT.

CHORDS AND WEBS ARE IDENTIFIED BY END JOINT NUMBERS/LETTERS.

Product Code Approvals

ICC-ES Reports:

ESR-1988, ESR-2362, ESR-2685, ESR-3282
ESR-4722, ESL-1388

Design General Notes

Trusses are designed for wind loads in the plane of the truss unless otherwise shown.

Lumber design values are in accordance with ANSI/TP1 section 6.3. These truss designs rely on Lumber values established by others.

© 2023 MITek® All Rights Reserved

MITek

ENGINEERING BY
TRENGO
A MITek Affiliate

MITek Engineering Reference Sheet: MIL-7473 rev. 1/2/2023

General Safety Notes

Failure to Follow Could Cause Property Damage or Personal Injury

1. Additional stability/bracing for truss system, e.g. diagonal or X-bracing, is always required. See BCSI.
2. Truss bracing must be designed by an engineer. For wide truss spacing, individual lateral braces themselves may require bracing, or alternative Tor I bracing should be considered.
3. Never exceed the design loading shown and never stack materials on inadequately braced trusses.
4. Provide copies of this truss design to the building designer, erection supervisor, property owner and all other interested parties.
5. Cut members to bear tightly against each other.
6. Place plates on each face of truss at each joint and embed fully. Knots and wane at joint locations are regulated by ANSI/TP1 1.
7. Design assumes trusses will be suitably protected from the environment in accord with ANSI/TP1 1.
8. Unless otherwise noted, moisture content of lumber shall not exceed 19% at time of fabrication.
9. Unless expressly noted, this design is not applicable for use with fire retardant, preservative treated, or green lumber.
10. Camber is a non-structural consideration and is the responsibility of truss fabricator. General practice is to camber for dead load deflection.
11. Plate type, size, orientation and location dimensions indicated are minimum plating requirements.
12. Lumber used shall be of the species and size, and in all respects, equal to or better than that specified.
13. Top chords must be sheathed or purlins provided at spacing indicated on design.
14. Bottom chords require lateral bracing at 10 ft. spacing, or less, if no ceiling is installed, unless otherwise noted.
15. Connections not shown are the responsibility of others.
16. Do not cut or alter truss member or plate without prior approval of an engineer.
17. Install and load vertically unless indicated otherwise.
18. Use of green or treated lumber may pose unacceptable environmental, health or performance risks. Consult with project engineer before use.
19. Review all portions of this design (front, back, words and pictures) before use. Reviewing pictures alone is not sufficient.
20. Design assumes manufacture in accordance with ANSI/TP1 1 Quality Criteria.
21. The design does not take into account any dynamic or other loads other than those expressly stated.