

**PLANS DESIGNED TO THE  
2018 NORTH CAROLINA STATE  
RESIDENTIAL BUILDING CODE**

MEAN ROOF HEIGHT: 17'-2"      HEIGHT TO RIDGE: 25'-6"

CLIMATE ZONE	ZONE 3A	ZONE 4A	ZONE 5A
FENESTRATION U-FACTOR	0.35	0.35	0.35
SKYLIGHT U-FACTOR	0.55	0.55	0.55
GLAZED FENESTRATION SHGC	0.30	0.30	0.30
CEILING R-VALUE	38 or 30ci	38 or 30ci	38 or 30ci
WALL R-VALUE	15	15	19
FLOOR R-VALUE	19	19	30
* BASEMENT WALL R-VALUE	5/13	10/15	10/15
** SLAB R-VALUE	0	10	10
* CRAWL SPACE WALL R-VALUE	5/13	10/15	10/19

\* 10/15" MEANS R-10 SHEATHING INSULATION OR R-13 CAVITY INSULATION  
 \*\* INSULATION DEPTH WITH MONOLITHIC SLAB 2" OR WITH INSULATION GAP TO BOTTOM OF FOOTING. INSULATION DEPTH WITH STEM WALL SLAB 2" OR TO BOTTOM OF FOUNDATION WALL

DESIGNED FOR WIND SPEED OF 120 MPH, 3 SECOND GUST (93 FASTEST MILE) EXPOSURE 'B'

COMPONENT & CLADDING DESIGNED FOR THE FOLLOWING LOADS

MEAN ROOF	UP TO 30'	30'-1" TO 35'	35'-1" TO 40'	40'-1" TO 45'
ZONE 1	14.2	-15.0	14.9	-15.8
ZONE 2	14.2	-18.0	14.9	-18.9
ZONE 3	14.2	-18.0	14.9	-18.9
ZONE 4	15.5	-16.0	16.3	-16.8
ZONE 5	15.5	-20.0	16.3	-21.0

DESIGNED FOR WIND SPEED OF 120 MPH, 3 SECOND GUST (101 FASTEST MILE) EXPOSURE 'B'

COMPONENT & CLADDING DESIGNED FOR THE FOLLOWING LOADS

MEAN ROOF	UP TO 30'	30'-1" TO 35'	35'-1" TO 40'	40'-1" TO 45'
ZONE 1	16.7	-18.0	17.5	-18.9
ZONE 2	16.7	-21.0	17.5	-22.1
ZONE 3	16.7	-21.0	17.5	-22.1
ZONE 4	18.2	-19.0	19.1	-20.0
ZONE 5	18.2	-24.0	19.1	-25.2

**ROOF VENTILATION**

**SECTION R806**

SQUARE FOOTAGE OF ROOF TO BE VENTED = 2,111 SQ.FT.  
 NET FREE CROSS VENTILATION NEEDED:  
 WITHOUT 50% TO 80% OF VENTING 3'-0" ABOVE EAVE = 14.07 SQ.FT.  
 WITH 50% TO 80% OF VENTING 3'-0" ABOVE EAVE; OR WITH CLASS 1 OR II VAPOR RETARDER ON WARM-IN-WINTER SIDE OF CEILING = 7.04 SQ.FT.

**GUARD RAIL NOTES**

**SECTION R312**

**R312.1 Where required.** Guards shall be located along open-sided walking surfaces, including stairs, ramps and landings, that are located more than 30 inches (762 mm) measured vertically to the floor or grade below at any point within 36 inches (914 mm) horizontally to the edge of the open side. Insect screening shall not be considered as a guard.  
**R312.2 Height.** Required guards at open-sided walking surfaces, including stairs, porches, balconies or landings, shall be not less than 36 inches (914 mm) high measured vertically above the adjacent walking surface, adjacent fixed seating or the line connecting the leading edges of the treads.

**Exceptions:**

- Guards on the open sides of stairs shall have a height not less than 34 inches (864 mm) measured vertically from a line connecting the leading edges of the treads.
  - Where the top of the guard also serves as a handrail on the open sides of stairs, the top of the guard shall not be not less than 34 inches (864 mm) and not more than 38 inches (965 mm) measured vertically from a line connecting the leading edges of the treads.
- R312.3 Opening limitations.** Required guards shall not have openings from the walking surface to the required guard height which allow passage of a sphere 4 inches (102 mm) in diameter.

**Exceptions:**

- The triangular openings at the open side of a stair, formed by the riser, tread and bottom rail of a guard, shall not allow passage of a sphere 6 inches (153 mm) in diameter.
- Guards on the open sides of stairs shall not have openings which allow passage of a sphere 43/8 inches (111 mm) in diameter.

**AIR LEAKAGE**

**Section N1102.4**

**N1102.4.1 Building thermal envelope.** The building thermal envelope shall be durably sealed with an air barrier system to limit infiltration. The sealing methods between dissimilar materials shall allow for differential expansion and contraction. For all homes, where present, the following shall be caulked, gasketed, weather stripped or otherwise sealed with an air barrier material or solid material consistent with Appendix E-2.4 of this code:

- Blocking and sealing floor/ceiling systems and under knee walls open to unconditioned or exterior space.
- Capping and sealing shafts or chases, including flue shafts.
- Capping and sealing soffit or dropped ceiling areas.

**NOTE:**  
**MONO SLAB - STONE TO RUN TO THE BOTTOM OF WINDOW**  
**STEM WALL - STONE TO FOUNDATION HEIGHT ONLY**

**WEST PRESERVE  
 LOT 30  
 3CG  
 TBD OLEANDER LN.  
 SANFORD, NC**

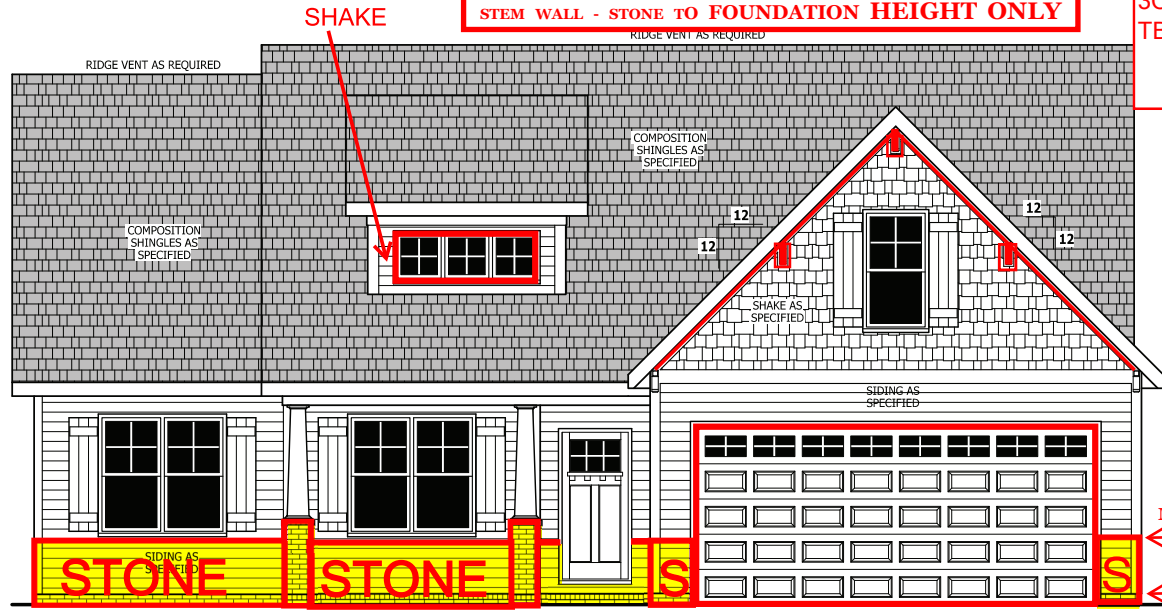

**FRONT ELEVATION**  
 SCALE 1/4" = 1'-0"

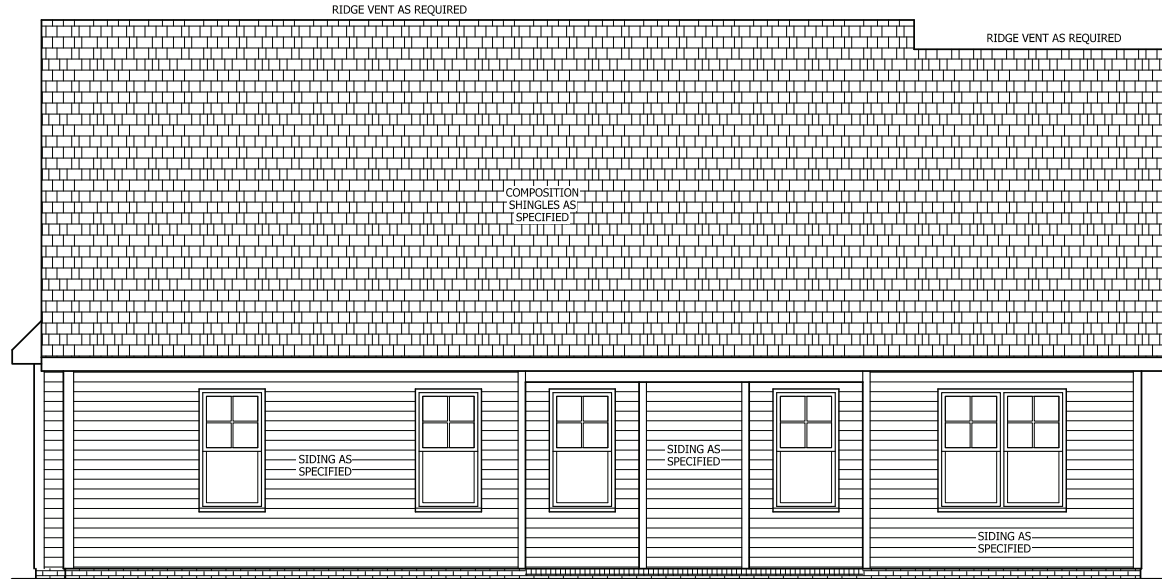

**REAR ELEVATION**  
 SCALE 1/4" = 1'-0"

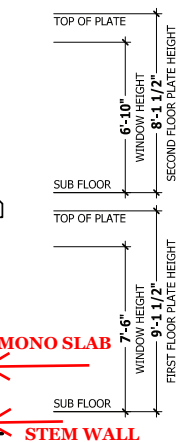

**SQUARE FOOTAGE**

HEATED	
FIRST FLOOR	1351 SQ.FT.
PLAYROOM	221 SQ.FT.
TOTAL	1572 SQ.FT.
HEATED OPTIONAL	
HALF BATH	28 SQ.FT.
TOTAL	28 SQ.FT.
UNHEATED	
FRONT PORCH	134 SQ.FT.
GARAGE	447 SQ.FT.
REAR PORCH	113 SQ.FT.
TOTAL	694 SQ.FT.
UNHEATED OPTIONAL	
THIRD GARAGE	307 SQ.FT.
TOTAL	307 SQ.FT.

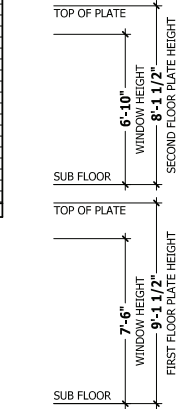

PURCHASER MUST VERIFY ALL DIMENSIONS AND CONDITIONS BEFORE CONSTRUCTION BEGINS. HAYNES HOME PLANS, INC. ASSUMES NO LIABILITY FOR CONTRACTORS PRACTICES AND PROCEDURES. CODES AND CONDITIONS MAY VARY WITH LOCATION. A LOCAL DESIGNER, ARCHITECT OR ENGINEER SHOULD BE CONSULTED BEFORE CONSTRUCTION. THESE DRAWINGS ARE INSTRUMENTS OF SERVICE AND AS SUCH SHALL REMAIN PROPERTY OF THE DESIGNER.

**FRONT & REAR ELEVATIONS**  
**SINCLAIR**

**HAYNES WEAVER HOMES**  
**HAYNES HOME PLANS, INC.**  
 910.690.2100 • 910.606.4696  
 P.O. BOX 702, WAKE FOREST, NC 27588 919.455.4180 FAX 919.455.4099

**SQUARE FOOTAGE**

HEATED	
FIRST FLOOR	1351 SQ.FT.
PLAYROOM	221 SQ.FT.
TOTAL	1572 SQ.FT.
HEATED OPTIONAL	
HALF BATH	28 SQ.FT.
TOTAL	28 SQ.FT.
UNHEATED	
FRONT PORCH	134 SQ.FT.
GARAGE	447 SQ.FT.
REAR PORCH	113 SQ.FT.
TOTAL	694 SQ.FT.
UNHEATED OPTIONAL	
THIRD GARAGE	307 SQ.FT.
TOTAL	307 SQ.FT.

© Copyright 2019  
 Haynes Home Plans, Inc.  
**3/6/2020**  
**190320B**  
**PAGE 1 OF 8**

\\ARCHIVE\Archive\Builder\Weaver Development Company, Inc.\200309B Sinclair\200309B Sinclair - Right.aec

# 3 CAR GARAGE

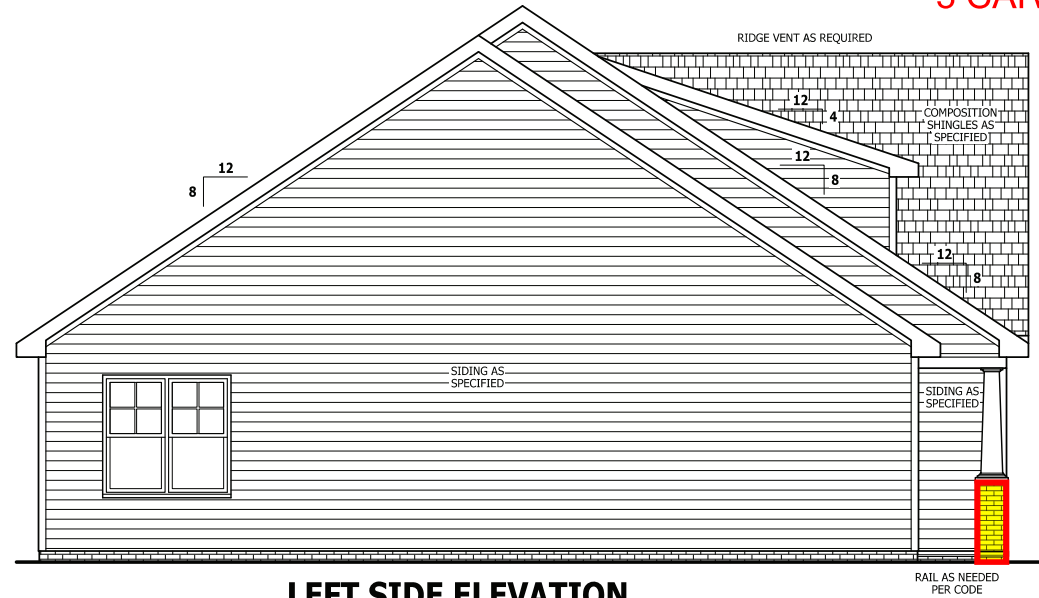

**LEFT SIDE ELEVATION**

SCALE 1/4" = 1'-0"

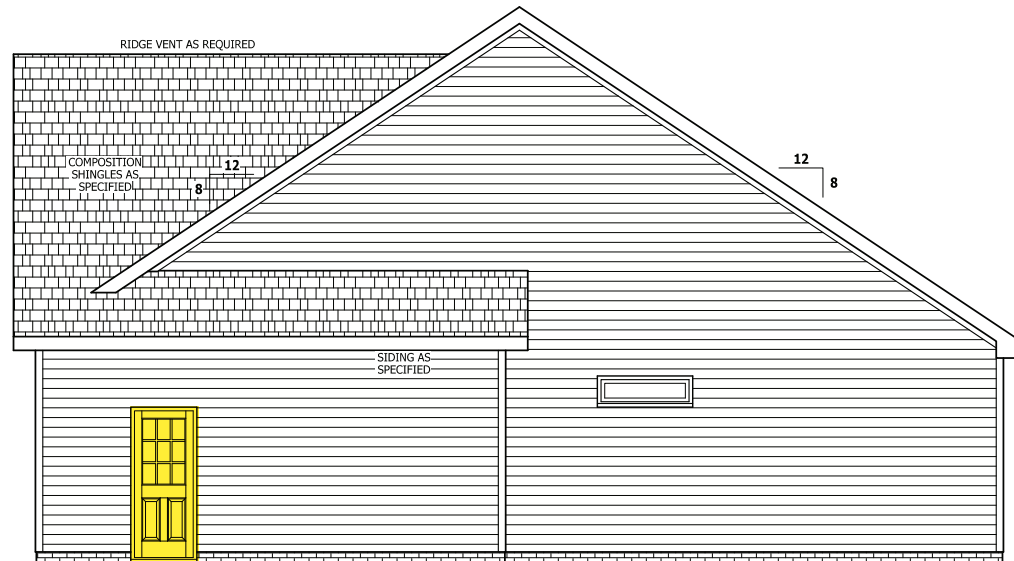
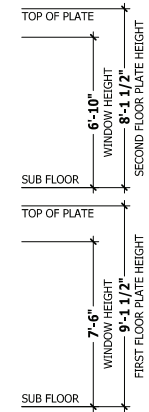

**RIGHT SIDE ELEVATION**

SCALE 1/4" = 1'-0"

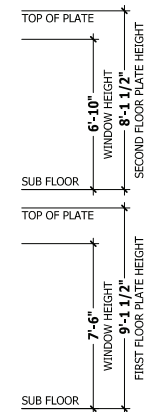

PURCHASER MUST VERIFY ALL DIMENSIONS AND CONDITIONS BEFORE CONSTRUCTION BEGINS. HAYNES HOME PLANS, INC. ASSUMES NO LIABILITY FOR CONTRACTORS PRACTICES AND PROCEDURES. CODES AND CONDITIONS MAY VARY WITH LOCATION. A LOCAL DESIGNER, ARCHITECT OR ENGINEER SHOULD BE CONSULTED BEFORE CONSTRUCTION. THESE DRAWINGS ARE INSTRUMENTS OF SERVICE AND AS SUCH SHALL REMAIN PROPERTY OF THE DESIGNER.

**LEFT & RIGHT ELEVATIONS**  
**SINCLAIR**

**WEAVER HOMES**  
910.630.2100 • 910.606.4696  
250 Weaver Drive, Fayetteville, NC 28404

**HAYNES HOME PLANS, INC.**  
P.O. Box 702, Wake Forest, NC 27588 919-435-4180 Fax 919-435-4099

SQUARE FOOTAGE	
HEATED	
FIRST FLOOR	1351 SQ. FT.
PLAYROOM	221 SQ. FT.
TOTAL	1572 SQ. FT.
HEATED OPTIONAL	
HALF BATH	28 SQ. FT.
TOTAL	28 SQ. FT.
UNHEATED	
FRONT PORCH	124 SQ. FT.
GARAGE	442 SQ. FT.
REAR PORCH	113 SQ. FT.
TOTAL	679 SQ. FT.
UNHEATED OPTIONAL	
1000 GARAGE	307 SQ. FT.
TOTAL	307 SQ. FT.

# 3 CAR GARAGE

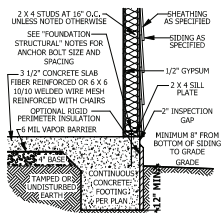

**A MONOLITHIC SECTION**  
SCALE 1/2" = 1'-0"

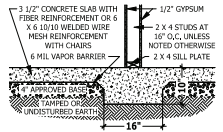

**B LUG FOOTING SECTION**  
SCALE 1/2" = 1'-0"

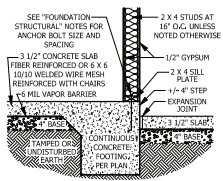

**C MONOLITHIC AT STEP**  
SCALE 1/2" = 1'-0"

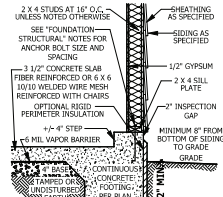

**D MONOLITHIC AT GARAGE**  
SCALE 1/2" = 1'-0"

## FOUNDATION STRUCTURAL

115 to 130 mph wind zone (1 1/2 to 2 1/2 story)  
**CONTINUOUS FOOTING:** 16" wide and 8" thick minimum, 20" wide minimum at brick veneer. Must extend 2" to either side of supported wall.  
**GIRDERS:** (3) 2 X 10 girder unless noted otherwise.  
**PIERS:** 16" X 16" piers with 8" solid masonry cap on 30" X 30" X 10" concrete footing with maximum pier height of 64" with hollow masonry and 160" with solid masonry.  
**POINT LOADS:** ■ designates significant point load and should have solid blocking to pier, girder or foundation wall.  
**115 and 120 MPH ANCHORS BOLTS:** 1/2" diameter anchor bolts embedded minimum 7", maximum 6'-0" on center, within 12" of plate ends, and minimum two anchor bolts per plate.  
**130 MPH ANCHORS BOLTS:** 1/2" diameter anchor bolts embedded minimum 15", maximum 4'-0" on center, within 12" of plate ends, and minimum two anchor bolts per plate.  
**CONCRETE:** Concrete shall have a minimum 28 day strength of 3000 psi and a maximum 5" slump. Air entrained per table 402.2. All concrete shall be in accordance with ACI standards. All samples for pumpcrete shall be taken from the exit end of the pump.  
**SOILS:** Allowable soil bearing pressure assumed to be 2000 PSF. The contractor must contact a geotechnical engineer and a structural engineer if unsatisfactory subsurface conditions are encountered. The surface area adjacent to the foundation wall shall be provided with adequate drainage, and shall be graded so as to drain surface water away from foundation walls.

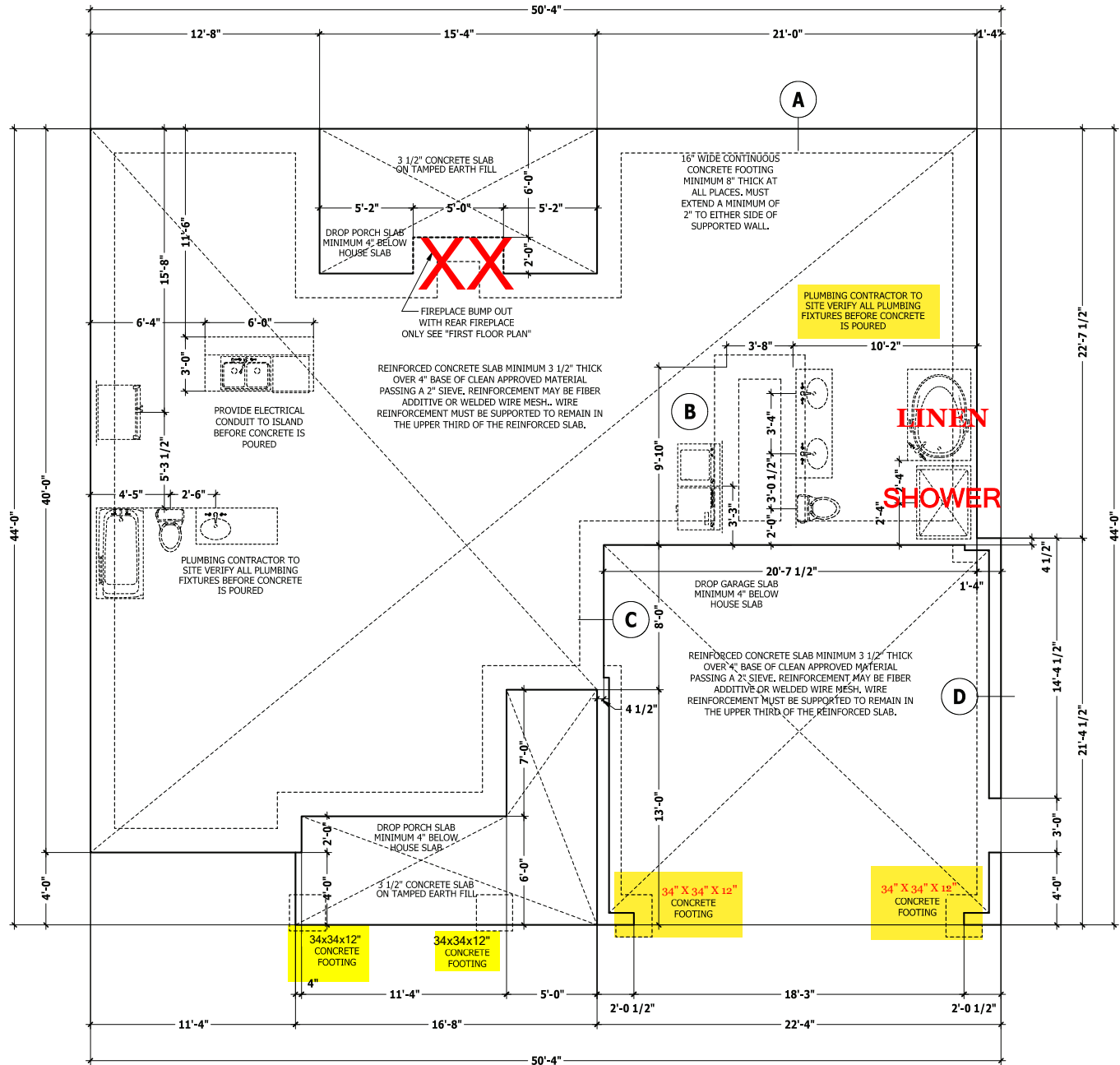

## MONOLITHIC SLAB PLAN

SCALE 1/4" = 1'-0"

PURCHASER MUST VERIFY ALL DIMENSIONS AND CONDITIONS BEFORE CONSTRUCTION BEGINS. HAYNES HOME PLANS, INC. ASSUMES NO LIABILITY FOR CONTRACTORS PRACTICES AND PROCEDURES. CODES AND CONDITIONS MAY VARY WITH LOCATION. A LOCAL DESIGNER, ARCHITECT OR ENGINEER SHOULD BE CONSULTED BEFORE CONSTRUCTION. THESE DRAWINGS ARE INSTRUMENTS OF SERVICE AND AS SUCH SHALL REMAIN PROPERTY OF THE DESIGNER.

MONOLITHIC SLAB PLAN  
**SINCLAIR**

WEAVER  
 HOMES  
 910.630.2100 • 910.606.4696

**HAYNES HOME PLANS, INC.**  
 P.O. BOX 702, WAKE FOREST, NC 27588 919.435.4180 FAX 919.435.4099

SQUARE FOOTAGE	
HEATED	
FIRST FLOOR	1351 SQ.FT.
PLAYROOM	221 SQ.FT.
TOTAL	1572 SQ.FT.
HEATED OPTIONAL	
HALF BATH	28 SQ.FT.
TOTAL	2604 SQ.FT.
UNHEATED	
FRONT PORCH	124 SQ.FT.
GARAGE	442 SQ.FT.
REAR PORCH	113 SQ.FT.
TOTAL	679 SQ.FT.
UNHEATED OPTIONAL	
1/2RD GARAGE	307 SQ.FT.
TOTAL	307 SQ.FT.

© Copyright 2019  
 Haynes Home Plans, Inc.  
**3/6/2020**  
**190320B**  
**PAGE 3 OF 8**

# DWELLING / GARAGE SEPARATION

REFER TO SECTIONS R302.5, R302.6, AND R302.7

**WALLS.** A minimum 1/2" gypsum board must be installed on all walls supporting floor/ceiling assemblies used for separation required by this section.  
**STAIRS.** A minimum of 1/2" gypsum board must be installed on the underside and exposed sides of all stairways.

**CEILING.** A minimum of 1/2" gypsum must be installed on the garage ceiling if there are no habitable room above the garage. If there are habitable room above the garage a minimum of 5/8" type X gypsum board must be installed on the garage ceiling.  
**OPENING PENETRATIONS.** Openings between the garage and residence shall be equipped with solid wood doors not less than 1 3/8 inches (35 mm) in thickness, solid or honeycomb core steel doors not less than 1 3/8 inches (35 mm) thick, or 20-minute fire-rated doors.

**DUCT PENETRATIONS.** Ducts in the garage and ducts penetrating the walls or ceilings separating the dwelling from the garage shall be constructed of a minimum No. 26 gage (0.48 mm) sheet steel or other approved material and shall have no openings into the garage.

**OTHER PENETRATIONS.** Penetrations through the separation required in Section R302.6 shall be protected as required by Section R302.11, Item 4.

3 CAR GARAGE

PURCHASER MUST VERIFY ALL DIMENSIONS AND CONDITIONS BEFORE CONSTRUCTION BEGINS. HAYNES HOME PLANS, INC. ASSUMES NO LIABILITY FOR CONTRACTORS PRACTICES AND PROCEDURES. CODES AND CONDITIONS MAY VARY WITH LOCATION. A LOCAL DESIGNER, ARCHITECT OR ENGINEER SHOULD BE CONSULTED BEFORE CONSTRUCTION. THESE DRAWINGS ARE INSTRUMENTS OF SERVICE AND AS SUCH SHALL REMAIN PROPERTY OF THE DESIGNER.

FIRST FLOOR PLAN  
**SINCLAIR**

WEAVER HOMES  
 910.630.2100 • 910.606.4696  
© Weaver Homes, Inc. Raleigh, NC 27603

**HAYNES HOME PLANS, INC.**  
 P.O. Box 702, Wake Forest, NC 27588 919.435.1180 FAX 919.435.0999

SQUARE FOOTAGE	
<b>HEATED</b>	
FIRST FLOOR	1351 SQ.FT.
PLAYROOM	221 SQ.FT.
TOTAL	1572 SQ.FT.
<b>HEATED OPTIONAL</b>	
HALF BATH	28 SQ.FT.
TOTAL	28 SQ.FT.
<b>UNHEATED</b>	
FRONT PORCH	134 SQ.FT.
GARAGE	447 SQ.FT.
REAR PORCH	113 SQ.FT.
TOTAL	694 SQ.FT.
<b>UNHEATED OPTIONAL</b>	
THIRD GARAGE	307 SQ.FT.
TOTAL	307 SQ.FT.

© Copyright 2019  
 Haynes Home Plans, Inc.  
**3/6/2020**  
**190320B**  
**PAGE 4 OF 8**

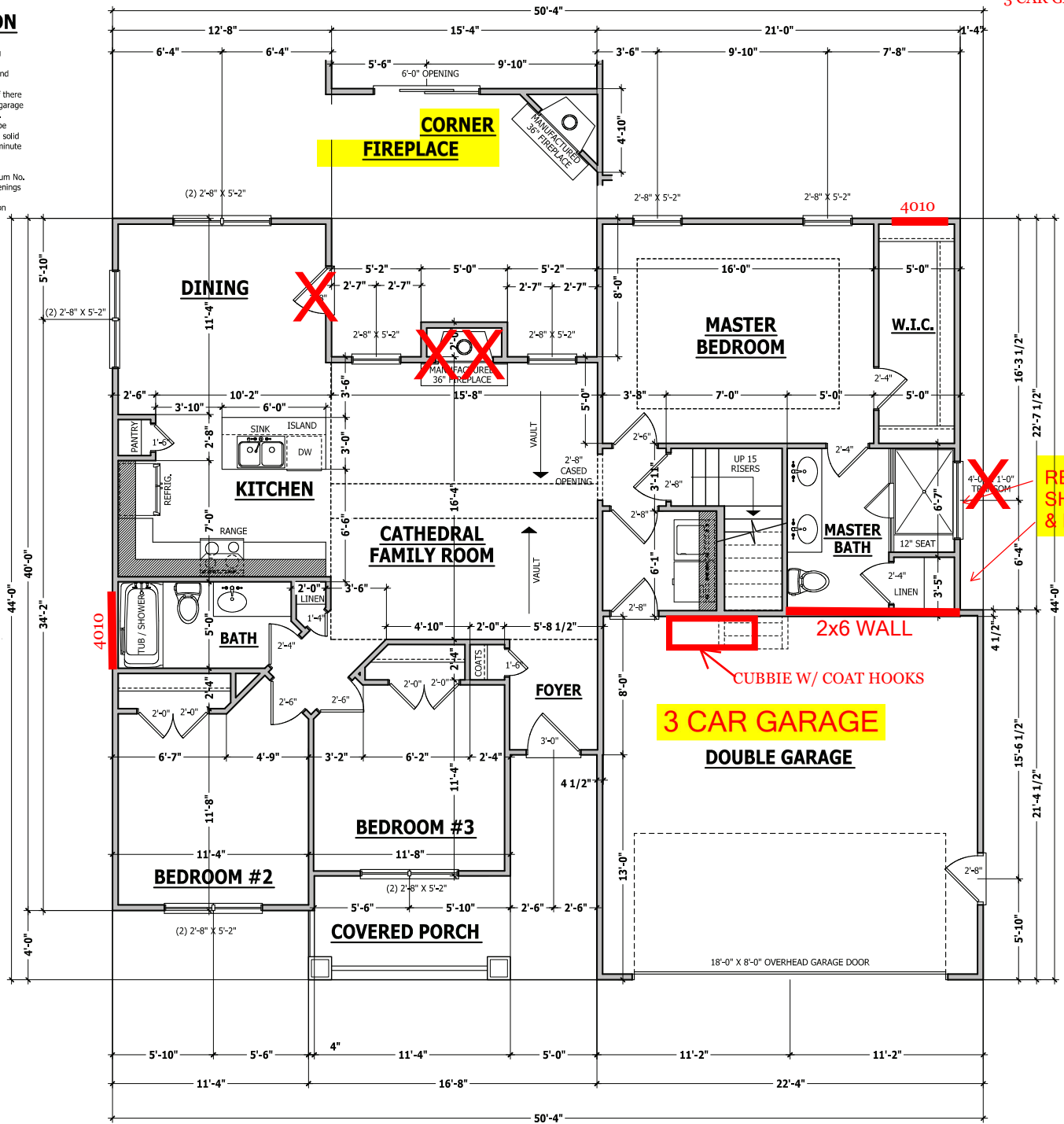

## FIRST FLOOR PLAN

SCALE 1/4" = 1'-0"

### WALL THICKNESSES

**Exterior walls and walls adjacent to a garage area** are drawn as 4" or as noted 2 X 6 are drawn as 6" to include 1/2" sheathing or gypsum. Subtract 1/2" for stud face.  
**Interior walls** are drawn as 3 1/2" or as noted 2 X 6 are drawn as 5 1/2", and do not include gypsum.

### SQUARE FOOTAGE

HEATED	
FIRST FLOOR	1351 SQ.FT.
PLAYROOM	221 SQ.FT.
TOTAL	1572 SQ.FT.
<b>HEATED OPTIONAL</b>	
HALF BATH	28 SQ.FT.
TOTAL	28 SQ.FT.
<b>UNHEATED</b>	
FRONT PORCH	134 SQ.FT.
GARAGE	447 SQ.FT.
REAR PORCH	113 SQ.FT.
TOTAL	694 SQ.FT.
<b>UNHEATED OPTIONAL</b>	
THIRD GARAGE	307 SQ.FT.
TOTAL	307 SQ.FT.

\\ARCHIVE\Archive\Builder\Weaver Development Company, Inc.\200309B Sinclair\200309B Sinclair - Right.aec

## STRUCTURAL NOTES

All construction shall conform to the latest requirements of the 2018 North Carolina Residential Building Code, plus all local codes and regulations. This document in no way shall be construed to supersede the code.

**JOB SITE PRACTICES AND SAFETY:** Haynes Home Plans, Inc. assumes no liability for contractor practices and procedures or safety program. Haynes Home Plans, Inc. takes no responsibility for the contractor's failure to carry out the construction work in accordance with the contract documents. All members shall be framed, anchored, and braced in accordance with good construction practice and the building code.

DESIGN LOADS	USE	LIVE LOAD (PSF)	DEAD LOAD (PSF)	DEFLECTION (LL)
	Attics without storage	10	10	L/240
	Attics with limited storage	20	10	L/360
	Attics with fixed stairs	40	10	L/360
	Balconies and decks	40	10	L/360
	Fire escapes	40	10	L/360
	Guardrails and handrails	200	—	—
	Guardrail in-fill components	50	—	—
	Passenger vehicle garages	50	10	L/360
	Rooms other than sleeping	40	10	L/360
	Sleeping rooms	30	10	L/360
	Stairs	40	—	L/360
	Snow	20	—	—

**FRAMING LUMBER:** All non treated framing lumber shall be SPF #2 (Fb = 875 PSI) or SYP #2 (Fb = 750 PSI) and all treated lumber shall be SYP #2 (Fb = 750 PSI) unless noted other wise.

### ENGINEERED WOOD BEAMS

Laminated veneer lumber (LVL) = Fb=2600 PSI, Fv=285 PSI, E=1.9x10<sup>6</sup> PSI  
Parallel strand lumber (PSL) = Fb=2900 PSI, Fv=290 PSI, E=2.0x10<sup>6</sup> PSI  
Laminated strand lumber (LSL) Fb=2250 PSI, Fv=400 PSI, E=1.55x10<sup>6</sup> PSI  
Install all connections per manufacturers instructions.

**TRUSS AND I-JOIST MEMBERS:** All roof truss and I-joist layouts shall be prepared in accordance with this document. Trusses and I-joists shall be installed according to the manufacturer's specifications. Any change in truss or I-joist layout shall be coordinated with Haynes Homes Plans, Inc.

**LINTELS:** Brick lintels shall be 3 1/2" x 3 1/2" x 1/4" steel angle for up to 6'-0" span, 6" x 4" x 5/16" steel angle with 6" leg vertical for spans up to 9'-0" unless noted otherwise. 3 1/2" x 3 1/2" x 1/4" steel angle with 1/2" bolts at 2'-0" on center for spans up to 18'-0" unless noted otherwise.

**FLOOR SHEATHING:** OSB or CDX floor sheathing minimum 1/2" thick for 16" on center joist spacing, minimum 5/8" thick for 19.2" on center joist spacing, and minimum 3/4" thick for 24" on center joist spacing.

**ROOF SHEATHING:** OSB or CDX roof sheathing minimum 3/8" thick for 16" on center rafters and 7/16" for 24" on center rafters.

**CONCRETE AND SOILS:** See foundation notes.

## BRACE WALL PANEL NOTES

**EXTERIOR WALLS:** All exterior walls to be sheathed with CS-WSP or CS-SFB in accordance with section R602.10.3 unless noted otherwise.

**GYPSUM:** All interior sides of exterior walls and both sides interior walls to have 1/2" gypsum installed. When not using method GB gypsum to be fastened per table R702.3.5. Method GB to be fastened per table R602.10.1.

**REQUIRED LENGTH OF BRACING:** Required brace wall length for each side of the circumscribed rectangle are interpolated per table R602.10.3. Methods CS-WSP and CS-SFB contribute their actual length. Method GB contributes 0.5 it's actual length. Method PF contributes 1.5 times its actual length.

**HD:** 800 lbs hold down hold down device fastened to the edge of the brace wall panel closets to the corner.

**Methods** Per Table R602.10.1

**CS-WSP:** Shall be minimum 3/8" OSB or CDX nailed at 6" on center at edges and 12" on center at intermediate supports with 5d common nails or 8d(2 1/2" long x 0.113" diameter).

**CS-SFB:** Shall be minimum 1/2" structural fiber board nailed at 3" on center at edges and 3" on center at intermediate supports with 1 1/2" long x 0.12" diameter galvanized roofing nails.

**GB:** Interior walls show as GB are to have minimum 1/2" gypsum board on both sides of the wall fastened at 7" on center at edges and 7" on center at intermediate supports with minimum 5d cooler nails or #6 screws.

**PF:** Portal frame per figure R602.10.1

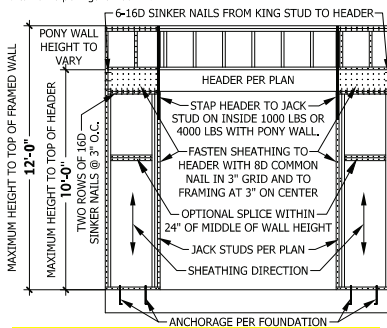

### PF PORTAL FRAME AT OPENING

(METHOD PF PER FIGURE AND SECTION R602.10.1)

SCALE 1/4" = 1'-0"

## EXTERIOR HEADERS

-(2) 2 X 6 WITH 1 JACK STUD EACH END

- KING STUDS EACH END OTHERWISE

- UNLESS NOTED OTHERWISE

HEADER SPAN < 3' 3'-4" 4'-8" 8'-12" 12'-16"

KING STUD(S) 1 2 3 5 6

## INTERIOR HEADERS

- LOAD BEARING HEADERS (2) 2 X 6 WITH

1 JACK STUD AND 1 KING STUD EACH END

UNLESS NOTED OTHERWISE

- NON LOAD BEARING HEADERS TO BE

LADDER FRAMED

### OPTIONAL CORNER FIREPLACE

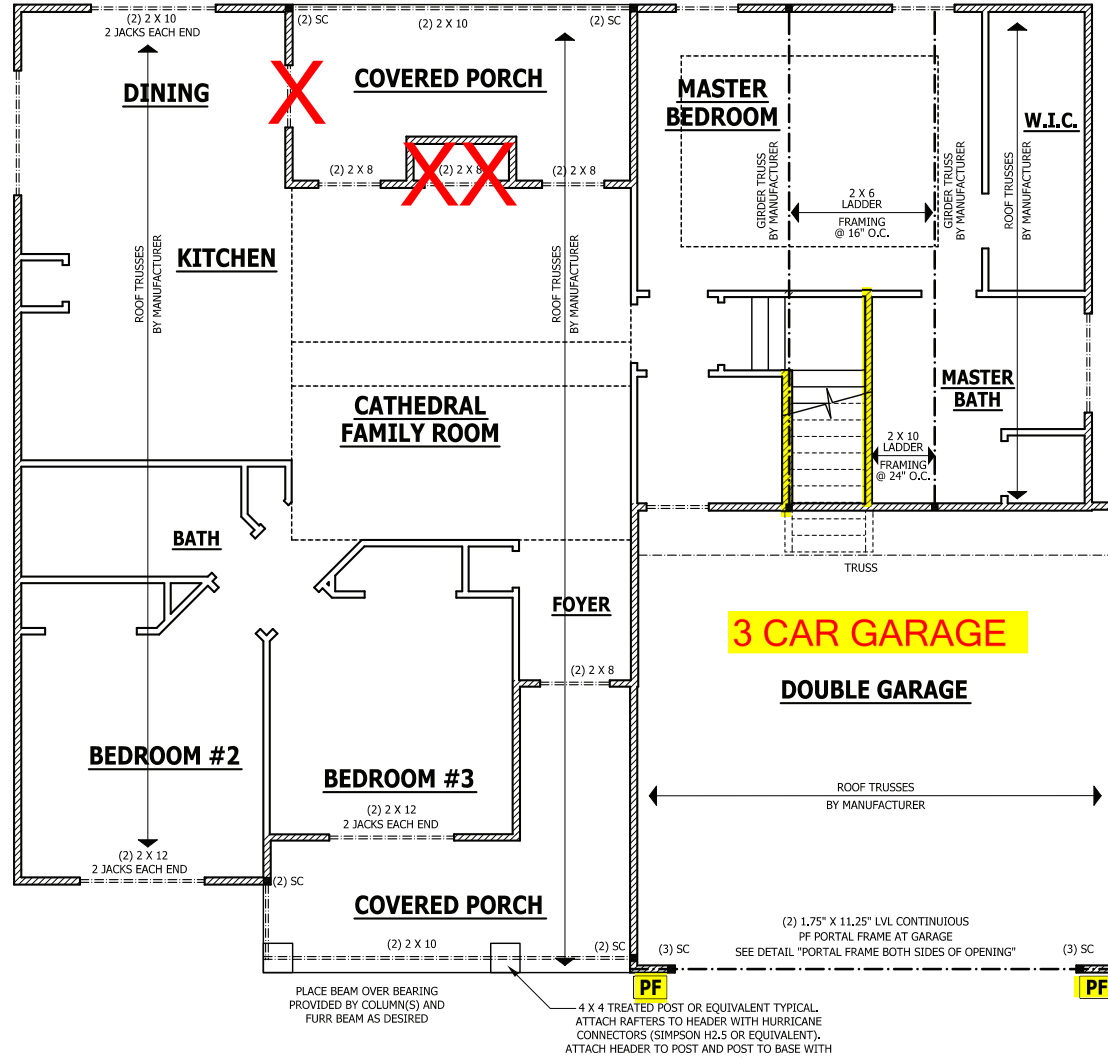

## FIRST FLOOR STRUCTURAL

SCALE 1/4" = 1'-0"

## ROOF TRUSS REQUIREMENTS

**TRUSS DESIGN:** Trusses to be designed and engineered in accordance with these drawings. Any variation with these drawings must be brought to Haynes Home Plans, Inc. attention before construction begins.

**KNEE WALL AND CEILING HEIGHTS:** All finished knee wall heights and ceiling heights are shown furred down 10" from roof decking for insulation. If for any reason the truss manufacturer fails to meet or exceed designated heel heights, finished knee wall heights, or finished ceiling heights shown on these drawings the finished square footage may vary. Any discrepancy must be brought to Haynes Home Plans, Inc. attention, so a suitable solution can be reached before construction begins. Any variation due to these conditions not being met is the responsibility of the truss manufacturer.

**ANCHORAGE:** All required anchors for trusses due to uplift or bearing shall meet the requirements as specified on the truss schematics.

**BEARING:** All trusses shall be designed for bearing on SPF #2 plates or ledgers unless noted otherwise.

**Plate Heights & Floor Systems:** See elevation page(s) for plate heights and floor system thicknesses.

FIRST FLOOR STRUCTURAL  
SINCLAIR

WEAVER HOMES  
910.630.2100 • 910.606.4696

HAYNES HOME PLANS, INC.  
P.O. BOX 702, WAKE FOREST, NC 27588 919-435-4180 FAX 919-435-9189

SQUARE FOOTAGE	
HEATED	1351 SQ.FT.
FRST FLOOR	222 SQ.FT.
PLAYROOM	127 SQ.FT.
TOTAL	1699 SQ.FT.
HEATED OPTIONAL	
FRST FLOOR	28 SQ.FT.
HALF BATH	28 SQ.FT.
TOTAL	56 SQ.FT.
UNHEATED	
FRONT PORCH	124 SQ.FT.
GAUGE	442 SQ.FT.
REAR PORCH	113 SQ.FT.
TOTAL	679 SQ.FT.
UNHEATED OPTIONAL	
FRST GARAGE	307 SQ.FT.
TOTAL	307 SQ.FT.

© Copyright 2019 Haynes Home Plans, Inc.

3/6/2020

190320B

PAGE 5 OF 8

## STRUCTURAL NOTES

All construction shall conform to the latest requirements of the 2018 North Carolina Residential Building Code, plus all local codes and regulations. This document in no way shall be construed to supersede the code.  
**JOB SITE PRACTICES AND SAFETY:** Haynes Home Plans, Inc. assumes no liability for contractor practices and procedures or safety program. Haynes Home Plans, Inc. takes no responsibility for the contractor's failure to carry out the construction work in accordance with the contract documents. All members shall be framed, anchored, and braced in accordance with good construction practice and the building code.

DESIGN LOADS	LIVE LOAD (PSF)	DEAD LOAD (PSF)	DEFLECTION (LL)
Attics without storage	10	-	L/240
Attics with limited storage	20	10	L/360
Attics with fixed stairs	40	10	L/360
Balconies and decks	40	10	L/360
Fire escapes	40	10	L/360
Guardrails and handrails	200	-	-
Guardrail in-fill components	50	-	-
Passenger vehicle garages	50	10	L/360
Rooms other than sleeping	40	10	L/360
Sleeping rooms	30	10	L/360
Stairs	40	-	L/360
Snow	20	-	-

**FRAMING LUMBER:** All non treated framing lumber shall be SPF #2 (Fb = 875 PSI) or SYP #2 (Fb = 750 PSI) and all treated lumber shall be SYP #2 (Fb = 750 PSI) unless noted otherwise.

**ENGINEERED WOOD BEAMS:**  
 Laminated veneer lumber (LVL) = Fb=2600 PSI, Fv=285 PSI, E=1.9x10<sup>6</sup> PSI  
 Parallel strand lumber (PSL) = Fb=2900 PSI, Fv=290 PSI, E=2.0x10<sup>6</sup> PSI  
 Laminated strand lumber (LSL) Fb=2250 PSI, Fv=400 PSI, E=1.55x10<sup>6</sup> PSI  
 Install all connections per manufacturers instructions.

**TRUSS AND I-JOIST MEMBERS:** All roof truss and I-joist layouts shall be prepared in accordance with this document. Trusses and I-joists shall be installed according to the manufacturer's specifications. Any change in truss or I-joist layout shall be coordinated with Haynes Homes Plans, Inc.

**LINTELS:** Brick lintels shall be 3 1/2" x 3 1/2" x 1/4" steel angle for up to 6'-0" span, 6" x 4" x 5/16" steel angle with 6" leg vertical for spans up to 9'-0" unless noted otherwise, 3 1/2" x 2 1/2" x 1/4" steel angle with 1/2" bolts at 2'-0" on center for spans up to 18'-0" unless noted otherwise.

**FLOOR SHEATHING:** OSB or CDX floor sheathing minimum 1/2" thick for 16" on center joist spacing, minimum 5/8" thick for 19.2" on center joist spacing, and minimum 3/4" thick for 24" on center joist spacing.

**ROOF SHEATHING:** OSB or CDX roof sheathing minimum 3/8" thick for 16" on center rafters and 7/16" for 24" on center rafters.

**CONCRETE AND SOILS:** See foundation notes.

## ROOF TRUSS REQUIREMENTS

**TRUSS DESIGN.** Trusses to be designed and engineered in accordance with these drawings. Any variation with these drawings must be brought to Haynes Home Plan, Inc. attention before construction begins.

**KNEE WALL AND CEILING HEIGHTS.** All finished knee wall heights and ceiling heights are shown furred down 10" from roof decking for insulation. If for any reason the truss manufacturer fails to meet or exceed designated heel heights, finished knee wall heights, or finished ceiling heights shown on these drawings the finished square footage may vary. Any discrepancy must be brought to Haynes Home Plans, Inc. attention, so a suitable solution can be reached before construction begins. Any variation due to these conditions not being met is the responsibility of the truss manufacturer.

**ANCHORAGE.** All required anchors for trusses due to uplift or bearing shall meet the requirements as specified on the truss schematics.

**BEARING.** All trusses shall be designed for bearing on SPF #2 plates or ledgers unless noted otherwise.

**Plate Heights & Floor Systems.** See elevation page(s) for plate heights and floor system thicknesses.

## EXTERIOR HEADERS

- (2) 2 X 6 WITH 1 JACK STUD EACH END UNLESS NOTED OTHERWISE

- KING STUDS EACH END PER TABLE BELOW

HEADER SPAN	< 3'	3'-4'	4'-8'	8'-12'	12'-16'
KING STUD(S)	1	2	3	5	6

## INTERIOR HEADERS

- LOAD BEARING HEADERS (2) 2 X 6 WITH 1 JACK STUD AND 1 KING STUD EACH END UNLESS NOTED OTHERWISE

- NON LOAD BEARING HEADERS TO BE LADDER FRAMED

## ATTIC ACCESS

### SECTION R807

**R807.1 Attic access.** An attic access opening shall be provided to attic areas that exceed 400 square feet (37.16 m<sup>2</sup>) and have a vertical height of 60 inches (1524 mm) or greater. The net clear opening shall not be less than 20 inches by 30 inches (508 mm by 762 mm) and shall be located in a hallway or other readily accessible location. A 30-inch (762 mm) minimum unobstructed headroom in the attic space shall be provided at some point above the access opening. See Section M1305.1.3 for access requirements where mechanical equipment is located in attics.

### Exceptions:

1. Concealed areas not located over the main structure including porches, areas behind knee walls, dormers, bay windows, etc. are not required to have access.
2. Pull down stair treads, stringers, handrails, and hardware may protrude into the net clear opening.

## WALL THICKNESSES

**Exterior walls and walls adjacent to a garage area** are drawn as 4" or as noted 2 X 6 are drawn as 6" to include 1/2" sheathing or gypsum. Subtract 1/2" for stud face.

**Interior walls** are drawn as 3 1/2" or as noted 2 X 6 are drawn as 5 1/2", and do not include gypsum.

3 CAR GARAGE

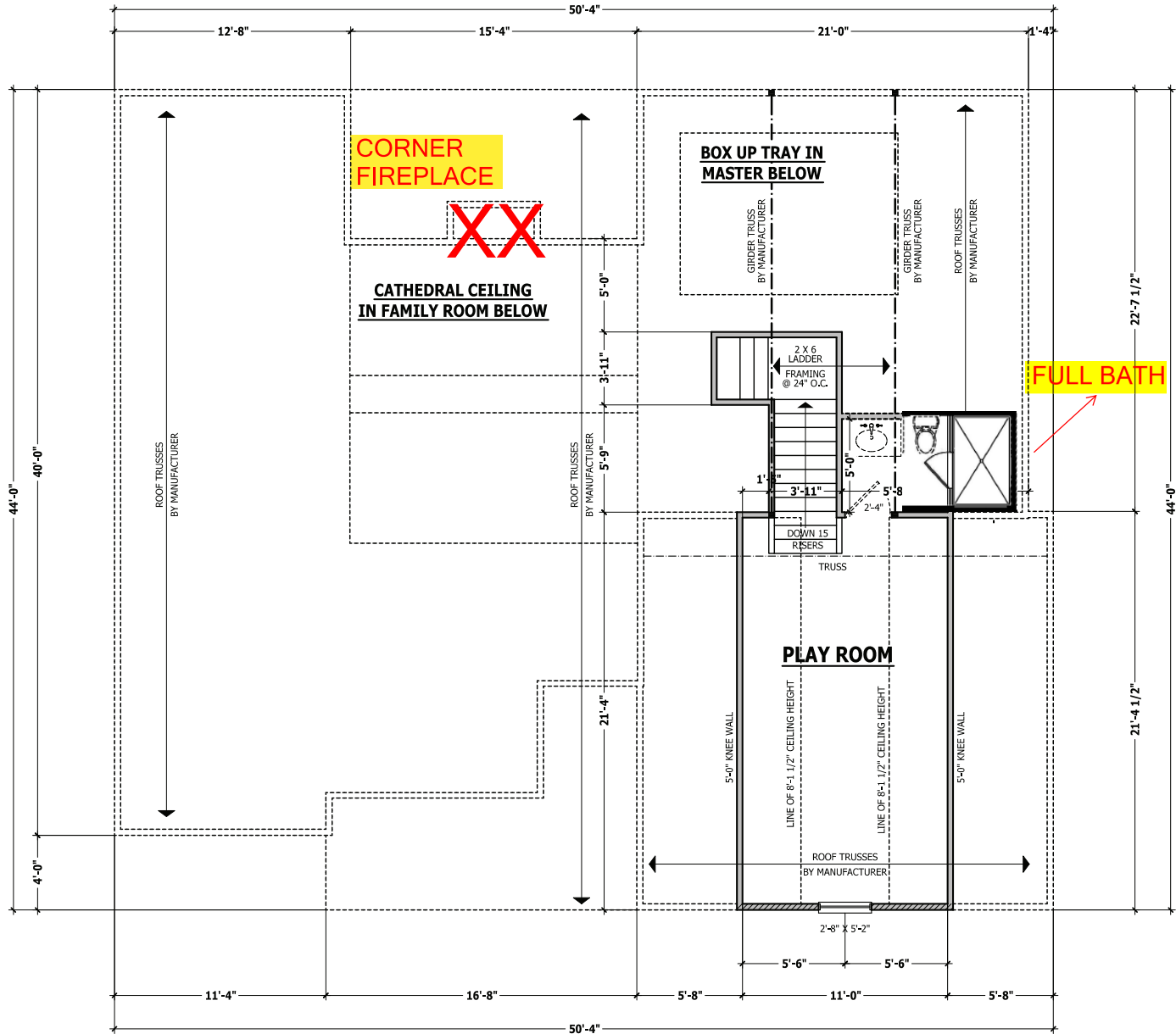

## SECOND FLOOR PLAN

SCALE 1/4" = 1'-0"

PURCHASER MUST VERIFY ALL DIMENSIONS AND CONDITIONS BEFORE CONSTRUCTION BEGINS. HAYNES HOME PLANS, INC. ASSUMES NO LIABILITY FOR CONTRACTOR'S PRACTICES AND PROCEDURES. CODES AND CONDITIONS MAY VARY WITH LOCATION. A LOCAL DESIGNER, ARCHITECT, OR ENGINEER SHOULD BE CONSULTED BEFORE CONSTRUCTION. THESE DRAWINGS ARE INSTRUMENTS OF SERVICE AND AS SUCH SHALL REMAIN PROPERTY OF THE DESIGNER.

SECOND FLOOR PLAN

SINCLAIR

WEAVER HOMES

910.630.2100 • 910.606.4696

HAYNES HOME PLANS, INC.

SQUARE FOOTAGE	
HEATED	
FIRST FLOOR	351 SQ.FT.
PLAYROOM	221 SQ.FT.
TOTAL	572 SQ.FT.
HEATED OPTIONAL	
HALF BATH	28 SQ.FT.
TOTAL	29 SQ.FT.
UNHEATED	
RIGHT PORCH	124 SQ.FT.
GARAGE	442 SQ.FT.
REAR PORCH	694 SQ.FT.
TOTAL	694 SQ.FT.
UNHEATED OPTIONAL	
1/2 CAR GARAGE	307 SQ.FT.
TOTAL	307 SQ.FT.

© Copyright 2019 Haynes Home Plans, Inc.

3/6/2020

190320B

PAGE 6 OF 8

3 CAR GARAGE

### ROOF TRUSS REQUIREMENTS

**TRUSS DESIGN.** Trusses to be designed and engineered in accordance with these drawings. Any variation with these drawings must be brought to Haynes Home Plans, Inc. attention before construction begins.  
**KNEE WALL AND CEILING HEIGHTS.** All finished knee wall heights and ceiling heights are shown furred down 10" from roof decking for insulation. If for any reason the truss manufacturer fails to meet or exceed designated heel heights, finished knee wall heights, or finished ceiling heights shown on these drawings the finished square footage may vary. Any discrepancy must be brought to Haynes Home Plans, Inc. attention, so a suitable solution can be reached before construction begins. Any variation due to these conditions not being met is the responsibility of the truss manufacturer.

**ANCHORAGE.** All required anchors for trusses due to uplift or bearing shall meet the requirements as specified on the truss schematics.  
**BEARING.** All trusses shall be designed for bearing on SPF #2 plates or ledgers unless noted otherwise.

**Plate Heights & Floor Systems.** See elevation page(s) for plate heights and floor system thicknesses.

- HEEL HEIGHT ABOVE FIRST FLOOR PLATE
- HEEL HEIGHT ABOVE SECOND FLOOR PLATE

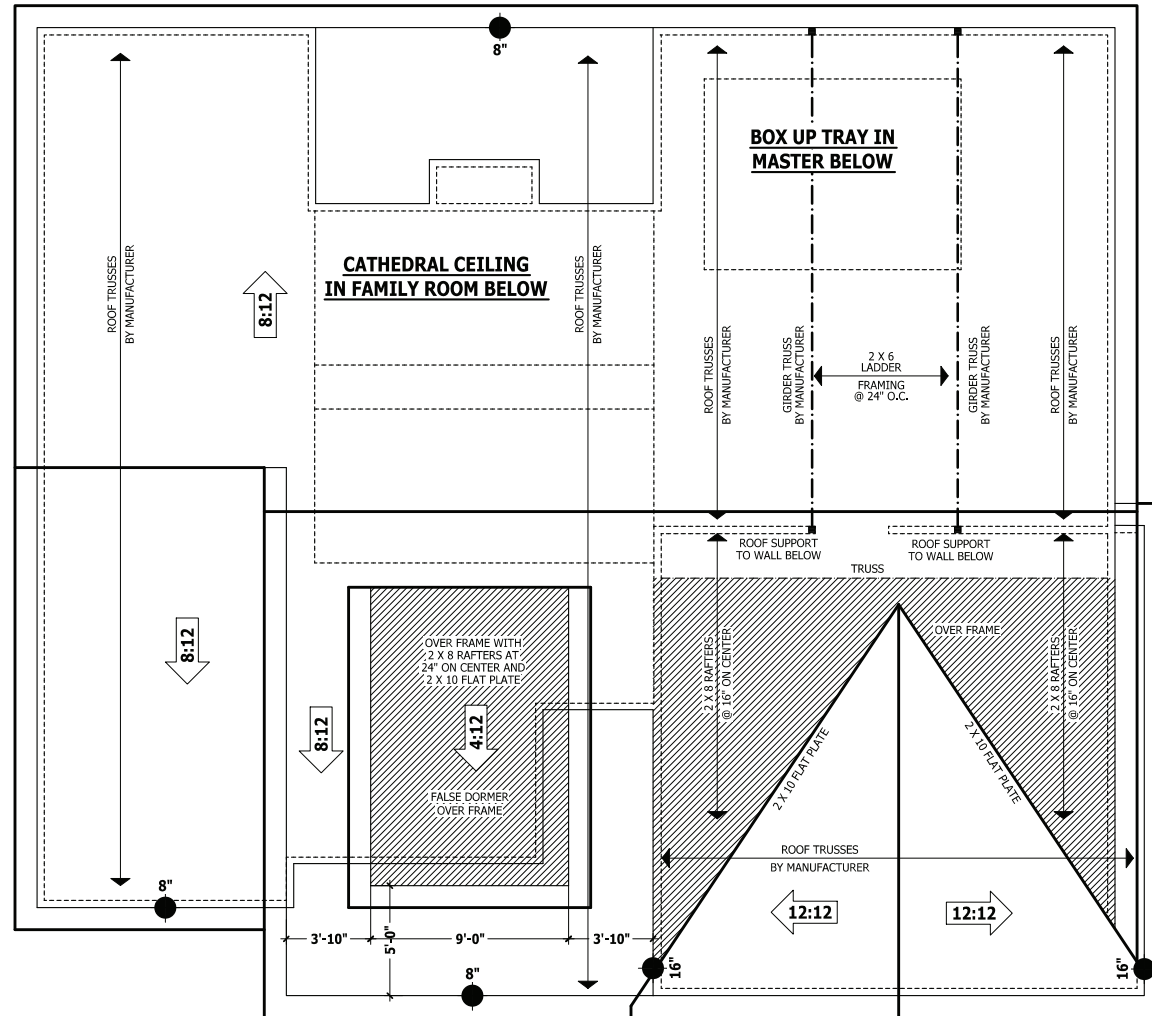

### ROOF PLAN

SCALE 1/4" = 1'-0"

PURCHASER MUST VERIFY ALL DIMENSIONS AND CONDITIONS BEFORE CONSTRUCTION BEGINS. HAYNES HOME PLANS, INC. ASSUMES NO LIABILITY FOR CONTRACTORS PRACTICES AND PROCEDURES. CODES AND CONDITIONS MAY VARY WITH LOCALITY. A LOCAL DESIGNER, ARCHITECT OR ENGINEER SHOULD BE CONSULTED BEFORE CONSTRUCTION. THESE DRAWINGS ARE INSTRUMENTS OF SERVICE AND AS SUCH SHALL REMAIN PROPERTY OF THE DESIGNER.

ROOF PLAN  
**SINCLAIR**

**WEAVER HOMES**  
 910.630.2100 • 910.606.4696  
250 Weaver Drive, Fayetteville, NC 28404

**HAYNES HOME PLANS, INC.**  
P.O. Box 702, Wake Forest, NC 27588 919-435-4180 Fax 919-435-4099

SQUARE FOOTAGE	
HEATED	3351 SQ.FT.
FIRST FLOOR	221 SQ.FT.
PLAYROOM	222 SQ.FT.
TOTAL	443 SQ.FT.
HEATED OPTIONAL	50 SQ.FT.
HALF BATH	28 SQ.FT.
TOTAL	28 SQ.FT.
UNHEATED	124 SQ.FT.
FRONT PORCH	442 SQ.FT.
REAR PORCH	112 SQ.FT.
TOTAL	554 SQ.FT.
UNHEATED OPTIONAL	30 SQ.FT.
1/2RD GARAGE	307 SQ.FT.
TOTAL	307 SQ.FT.

© Copyright 2019  
 Haynes Home Plans, Inc.  
**3/6/2020**  
**190320B**  
**PAGE 7 OF 8**

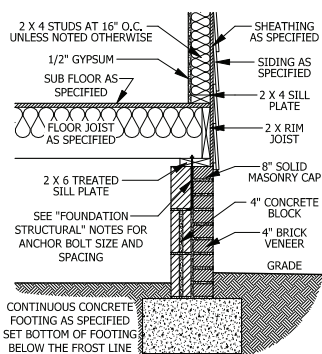

**A CRAWL SPACE WALL**  
SCALE 3/4" = 1'-0"

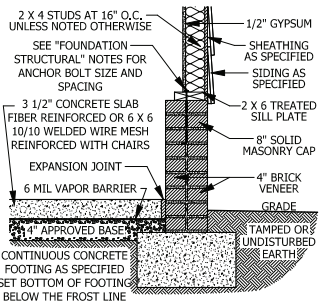

**D GARAGE STEM WALL**  
SCALE 3/4" = 1'-0"

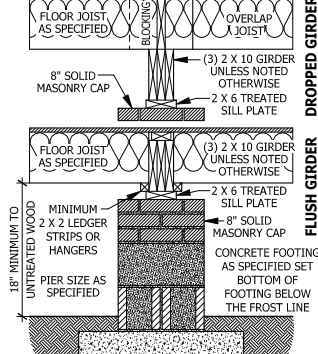

**B DROPPED/ FLUSH PIER**  
SCALE 3/4" = 1'-0"

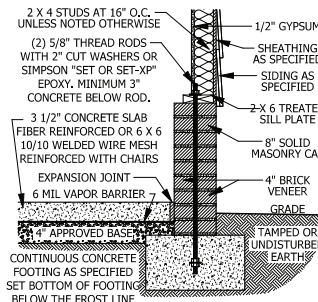

**E <48\"/>**

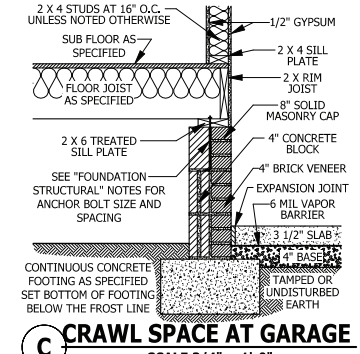

**C CRAWL SPACE AT GARAGE**  
SCALE 3/4" = 1'-0"

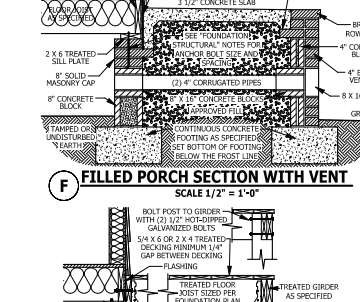

**F FILLED PORCH SECTION WITH VENT**  
SCALE 1/2" = 1'-0"

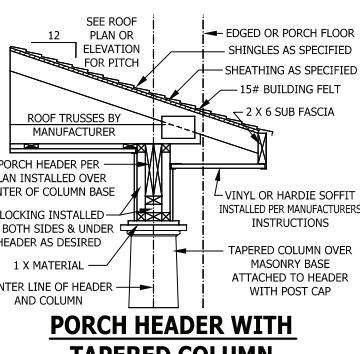

**PORCH HEADER WITH TAPERED COLUMN**  
SCALE 3/4" = 1'-0"

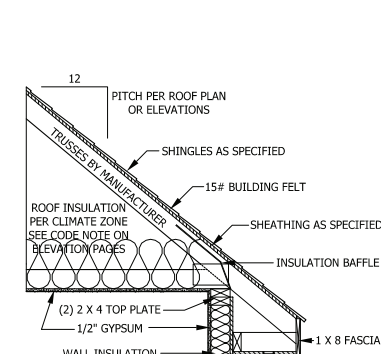

**TYPICAL WALL DETAIL**  
SCALE 3/4" = 1'-0"

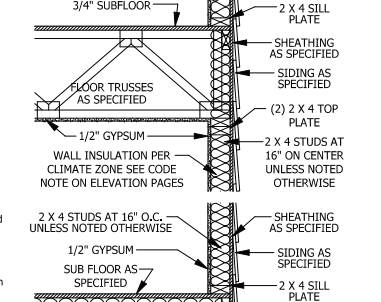

**TYPICAL WALL DETAIL**  
SCALE 3/4" = 1'-0"

**DECK STAIR NOTES**

**SECTION AM110**  
**AM110.1** Stairs shall be constructed per Figure AM110. Stringer spans shall be no greater than 7 foot span between supports. Spacing between stringers shall be based upon decking material used per AM107.1. Each Stringer shall have minimum 3/2 inches between step cut and back of stringer. If used, suspended headers shall be attached with 3/8 inch galvanized bolts with nuts and washers to securely support stringers at the top.

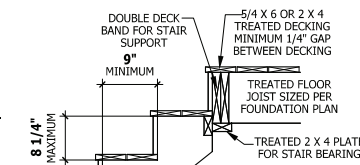

**FIGURE AM110**  
**TYPICAL DECK STAIR DETAIL**  
SCALE 3/4" = 1'-0"

**DECK BRACING**

**SECTION AM109**  
**AM109.1** Deck bracing. Decks shall be braced to provide lateral stability. The following are acceptable means to provide lateral stability.  
**AM109.1.1** When the deck floor height is less than 4'-0" above finished grade per Figure AM109 and the deck is attached to the structure in accordance with Section AM104, lateral bracing is not required.  
**AM109.1.2** 4 x 4 wood knee braces may be provided on each column in both directions. The knee braces shall attach to each post at a point not less than 1/3 of the post length from the top of the post, and the braces shall be angled between 45 degrees and 60 degrees from the horizontal. Knee braces shall be bolted to the post and the girder/double band with one 5/8 inch hot dipped galvanized bolt with nut and washer at both ends of the brace per Figure AM109.1  
**AM109.1.3** For freestanding decks without knee braces or diagonal bracing, lateral stability may be provided by embedding the post in accordance with Figure AM109.2 and the following:  

POST SIZE	MIN. TRIBUTARY AREA	MAX. POST HEIGHT	EMBEDMENT DEPTH	CONCRETE DIAMETER
4 x 4	48 SF	4'-0"	2'-6"	1'-0"
6 x 6	120 SF	6'-0"	3'-6"	1'-8"

  
**AM109.1.4** 2 x 6 diagonal vertical cross brace may be provided in two perpendicular directions for freestanding decks or parallel to the structure at the exterior column line for attached decks. The 2 x 6's shall be attached to the posts with one 5/8 inch hot dipped galvanized bolt with nut and washer at each end of each bracing member per Figure AM109.3.  
**AM109.1.5** For embedment of piles in Coastal Regions, see Chapter 45.



**WEEP SCREED**  
SCALE 3/4" = 1'-0"



**G DECK ATTACHMENT**  
SCALE 1/2" = 1'-0"

**SMOKE ALARMS**

**SECTION R314**  
**R314.1** Smoke detection and notification. All smoke alarms shall be listed in accordance with UL 217 and installed in accordance with the provisions of this code and the household fire warning equipment provisions of NFPA 72.  
**R314.2** Smoke detection systems. Household fire alarm systems installed in accordance with NFPA 72 that include smoke alarms, or a combination of smoke detector and audible notification device installed as required by this section for smoke alarms, shall be permitted. The household fire alarm system shall provide the same level of smoke detection and alarm as required by this section for smoke alarms. Where a household fire warning system is installed using a combination of smoke detector and audible notification device(s), it shall become a permanent fixture of the occupancy and owned by the homeowner. The system shall be monitored by an approved supervising station and be maintained in accordance with NFPA 72.  
**Exception:** Where smoke alarms are provided meeting the requirements of Section R314.4.  
**R314.3** Location. Smoke alarms shall be installed in the following locations:  
1. In each sleeping room.  
2. Outside each separate sleeping area in the immediate vicinity of the bedrooms.  
3. On each additional story of the dwelling, including basements and habitable attics (finished) but not including crawl spaces, uninhabited (unfinished) attics and uninhabitable (unfinished) attics-stories. In dwellings or dwelling units with split levels and without an intervening door between the adjacent levels, a smoke alarm installed on the upper level shall suffice for the adjacent lower level provided that the lower level is less than one full story below the upper level.  
When more than one smoke alarm is required to be installed within an individual dwelling unit the alarm devices shall be interconnected in such a manner that the actuation of one alarm will activate all of the alarms in the individual unit.  
**R314.4** Power source. Smoke alarms shall receive their primary power from the building wiring when such wiring is served from a commercial source, and when primary power is interrupted, shall receive power from a battery. Wiring shall be permanent and without a disconnecting switch other than those required for overcurrent protection. Smoke alarms shall be interconnected.

**CARBON MONOXIDE ALARMS**

**SECTION R315**  
**R315.1** Carbon monoxide alarms. In new construction, dwelling units shall be provided with an approved carbon monoxide alarm installed outside of each separate sleeping area in the immediate vicinity of the bedroom(s) as directed by the alarm manufacturer.  
**R315.2** Where required in existing dwellings. In existing dwellings, where interior alterations, repairs, fuel-fired appliance replacements, or additions requiring a permit occur, or where one or more sleeping rooms are added or created, carbon monoxide alarms shall be provided in accordance with Section 315.1.  
**R315.3** Alarm requirements. The required carbon monoxide alarms shall be audible in all bedrooms over background noise levels with all intervening doors closed. Single station carbon monoxide alarms shall be listed as complying with UL 2034 and shall be installed in accordance with the code and the manufacturer's installation instructions.

**STAIRWAY NOTES**

**R311.7**  
**R311.7.2** Headroom. The minimum headroom in all parts of the stairway shall not be less than 6 feet 8 inches (2032 mm) measured vertically from the sloped line adjoining the tread nosing or from the floor surface of the landing or platform at that portion of the stairway.  
**R311.7.4** Stair treads and risers. Stair treads and risers shall meet the requirements of this section. For the purposes of this section all dimensions and dimensional surfaces shall be exclusive of carpets, rugs or runners.  
**R311.7.4.1** Riser height. The maximum riser height shall be 8 1/4 inches (210 mm). The riser shall be measured vertically between leading edges of the adjacent treads.  
**R311.7.4.2** Tread depth. The minimum tread depth shall be 9 inches (229 mm). The tread depth shall be measured horizontally between the vertical planes of the foremost projection of adjacent treads and at a right angle to the tread's leading edge. Winder treads shall have a minimum tread depth of 9 inches (229 mm) measured as above at a point 12 inches (305 mm) from the side where the treads are narrower. Winder treads shall have a minimum tread depth of 4 inches (102 mm) at any point.  
**R311.7.4.3** Profile. The radius of curvature at the nosing shall be no greater than 9/16 inch (14 mm). A nosing not less than 3/4 inch (19 mm) but not more than 1 1/4 inches (32 mm) shall be provided on stairways with solid risers.  
**R311.7.7** Handrails. Handrails shall be provided on at least one side of each continuous run of treads or flight with four or more risers.  
**R311.7.7.1** Height. Handrail height, measured vertically from the sloped planes adjoining the tread nosing, or finish surface of ramp slope, shall be not less than 34 inches (864 mm) and not more than 38 inches (965 mm).  
**Exceptions:**  
1. The use of a volute, turnout or starting easing shall be allowed over the lowest tread.  
2. When handrail fittings or bindings are used to provide continuous transition between flights, the transition from handrail to handrail, or used at the start of a flight, the handrail height at the fittings or bindings shall be permitted to exceed the maximum height.  
**R311.7.7.2** Continuity. Handrails for stairways shall be continuous for the full length of the flight, from a point directly above the top riser of the flight to a point directly above the lowest riser of the flight. Handrail ends shall be returned or shall terminate in newel posts or safety terminals. Handrails adjacent to a wall shall have a space of not less than 1 1/2 inch (38 mm) between the wall and the handrails.  
**Exceptions:**  
1. Handrails shall be permitted to be interrupted by a newel post.  
2. The use of a volute, turnout, starting easing or starting newel shall be allowed over the lowest tread.  
3. Two or more separate rails shall be considered continuous if the termination of the rails occurs within 6 inches (152 mm) of each other. If transitioning between a wall-mounted handrail and a guardrail/handrail, the wall-mounted rail must return into the wall.

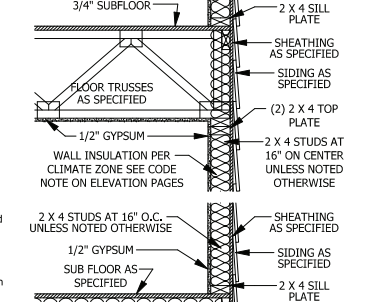

**TYPICAL STAIR DETAIL**  
SCALE 1/4" = 1'-0"

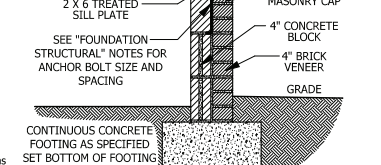

**TYPICAL STAIR DETAIL**  
SCALE 1/4" = 1'-0"

PURCHASER MUST VERIFY ALL DIMENSIONS AND CONDITIONS BEFORE CONSTRUCTION BEGINS. HAYNES HOME PLANS, INC. ASSUMES NO LIABILITY FOR CONTRACTORS PRACTICES AND PROCEDURES. CODES AND CONDITIONS MAY VARY WITH LOCATION. A LOCAL DESIGNER, ARCHITECT OR ENGINEER SHOULD BE CONSULTED BEFORE CONSTRUCTION. THESE DRAWINGS ARE INSTRUMENTS OF SERVICE AND AS SUCH SHALL REMAIN PROPERTY OF THE DESIGNER.

**TYPICAL DETAILS**  
**SINCLAIR**

**HAYNES WE AVER HOMES**  
910.630.2100 • 910.606.4696  
P.O. Box 702, Wake Forest, NC 27588 919.435.8180 1-800-91-9099

**HAYNES WE AVER HOMES HOME PLANS, INC.**  
P.O. Box 702, Wake Forest, NC 27588 919.435.8180 1-800-91-9099

**SQUARE FOOTAGE HEATED**

FIRST FLOOR	1351 SQ.FT.
PLAYROOM	221 SQ.FT.
TOTAL	1572 SQ.FT.

**HEATED OPTIONAL**

HALF BATH	28 SQ.FT.
TOTAL	28 SQ.FT.

**UNHEATED**

SCREENED FRONT PORCH	124 SQ.FT.
GARAGE	113 SQ.FT.
REAR PORCH	442 SQ.FT.
TOTAL	679 SQ.FT.

**UNHEATED OPTIONAL**

VISIBL GLAZED	302 SQ.FT.
TOTAL	302 SQ.FT.



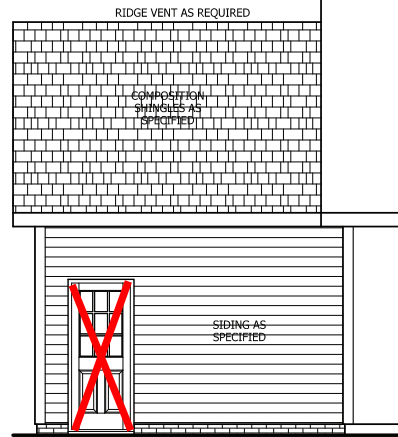

**REAR ELEVATION**

SCALE 1/4" = 1'-0"

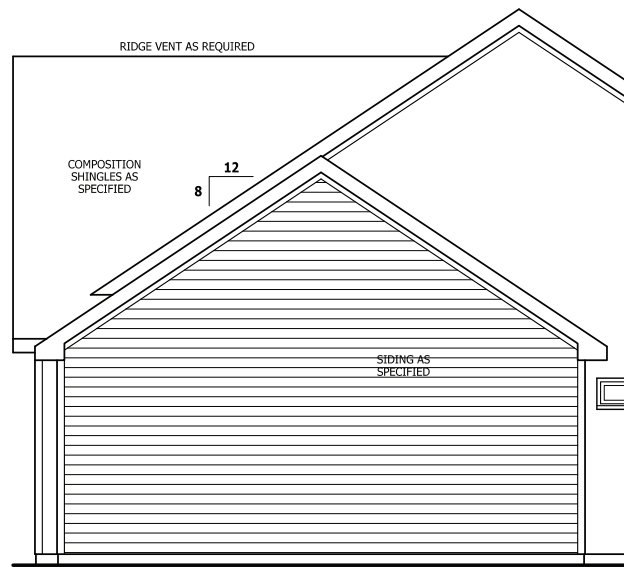

**SIDE ELEVATION**

SCALE 1/4" = 1'-0"

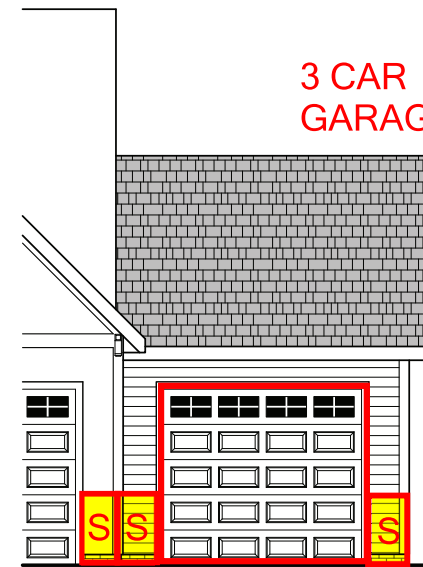
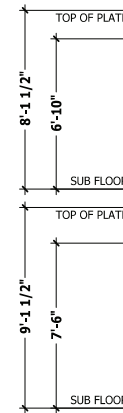

**FRONT ELEVATION**

SCALE 1/4" = 1'-0"

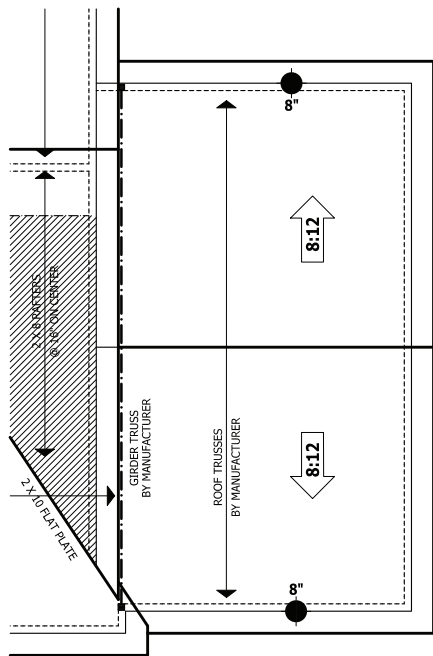

**ROOF PLAN**

SCALE 1/4" = 1'-0"

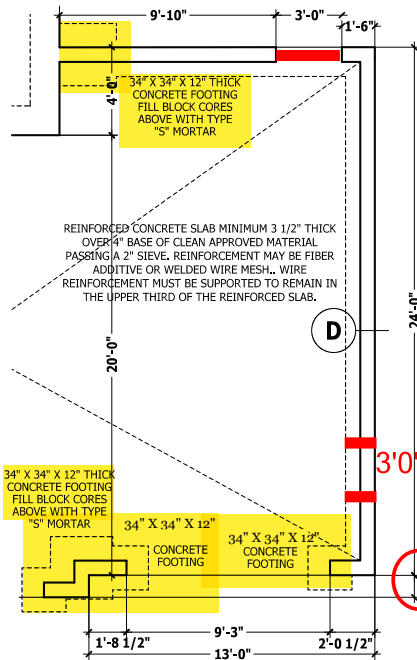

**MONOLITHIC PLAN**

SCALE 1/4" = 1'-0"

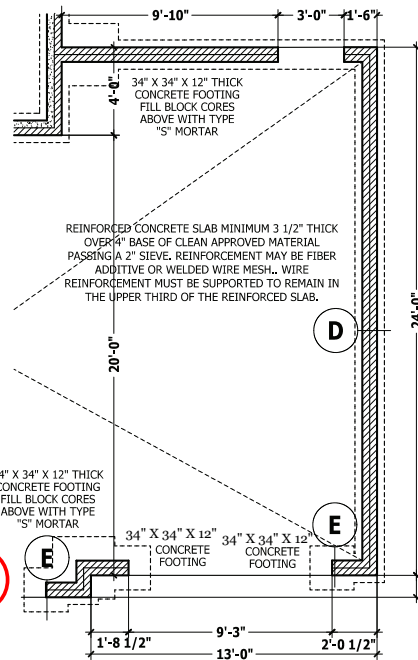

**CRAWL / STEMWALL PLAN**

SCALE 1/4" = 1'-0"

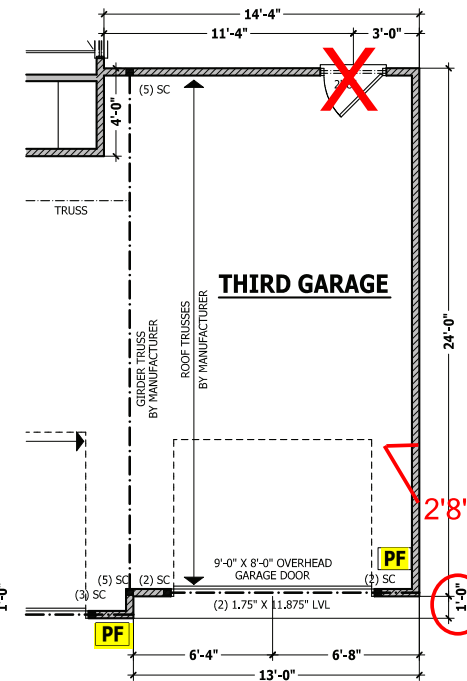

**FIRST FLOOR PLAN**

SCALE 1/4" = 1'-0"

PURCHASER MUST VERIFY ALL DIMENSIONS AND CONDITIONS BEFORE CONSTRUCTION BEGINS. HAYNES HOME PLANS, INC. ASSUMES NO LIABILITY FOR CONTRACTORS PRACTICES AND PROCEDURES. CODES AND CONDITIONS MAY VARY WITH LOCATION. A LOCAL DESIGNER, ARCHITECT OR ENGINEER SHOULD BE CONSULTED BEFORE CONSTRUCTION. THESE DRAWINGS ARE INSTRUMENTS OF SERVICE AND AS SUCH SHALL REMAIN PROPERTY OF THE DESIGNER.

**THIRD CAR GARAGE**  
**SINCLAIR**

**HAYNES WEAVER HOMES**  
P.O. BOX 702, HAYES FOREST, NC 27538 919-435-4180 FAX 919-435-4189  
910.630.2100 • 910.606.4696

**HAYNES WEAVER HOMES INC.**  
HOME PLANS, INC.

SQUARE FOOTAGE	
HEATED	3351 SQ.FT.
FIRST FLOOR	221 SQ.FT.
PLAYROOM	29 SQ.FT.
UNHEATED	302 SQ.FT.
HALF BATH	28 SQ.FT.
TOTAL	29 SQ.FT.
UNHEATED	124 SQ.FT.
ROOF FLOOR	442 SQ.FT.
GARAGE	113 SQ.FT.
REAR PORCH	694 SQ.FT.
TOTAL	1650 SQ.FT.
UNHEATED OPTIONAL	302 SQ.FT.
THIRD GARAGE	387 SQ.FT.
TOTAL	302 SQ.FT.

© Copyright 2019 Haynes Home Plans, Inc.  
3/6/2020  
190320B  
ADDENDUM