

Residence for Garman Homes Lot 0252 Serenity Fuquay Varina, North Carolina



This document is property of Garman Homes Inc. and was prepared for their use only. The plans, elevations, illustrations, and other material contained within this set may not be reproduced, either in part or wholly, in any manner without the express written permission of Garman Homes, Inc. All right reserved and protected under federal law.

Project Number	Project Number
Plan Number	FP-1644

INDEX TO DRAWINGS

- COVER SHEET
 1 FRONT & LEFT SIDE ELEVATIONS
 2 REAR & RIGHT SIDE ELEVATIONS
 3 FIRST & SECOND FLOOR PLANS
 E FIRST & SECOND FLOOR ELECTRICAL PLANS
 M FIRST & SECOND FLOOR MECHANICAL PLANS
 P FIRST FLOOR PLUMBING PLAN
 D CONSTRUCTION DETAILS

- S1 FOUNDATION PLAN - CRAWLSPACE STANDARD
 S2 FIRST FLOOR FRAMING PLAN
 S3 SECOND FLOOR FRAMING
 S4 ROOF FRAMING PLAN
 S5 OPTIONAL IN-LAW SUITE DETAILS
 SD1 STRUCTURAL DETAILS
 SD2 STRUCTURAL DETAILS
 SD3 STRUCTURAL DETAILS
 SPEC CONSTRUCTION SPECIFICATIONS

GENERAL NOTES

- ALL WORK TO BE DONE IN STRICT ACCORDANCE WITH NORTH CAROLINA STATE RESIDENTIAL BUILDING CODE, 2018 EDITION (HEREWITH SHOWN AS N.C.S.R.B.C.).
- DIMENSIONS SHOWN ON DRAWINGS GOVERN OVER SCALE.
- STUD WALL DESIGN SHALL CONFORM TO ALL N.C.S.R.B.C. REQUIREMENTS
- CONTRACTOR SHALL USE TEMPERED SAFETY GLASS IN ALL LOCATIONS AS REQUIRED BY N.C.S.R.B.C., 2018 EDITION, SECTION R308.4.
- ANY HABITABLE ROOM SHALL MEET ALL LIGHT/VENTILATION AND EGRESS AS REQUIRED BY N.C.S.R.B.C. 2018 EDITION, SECTIONS R-303.1 AND R-310.1.
- ALL EXTERIOR WALLS SHOWN ON FLOOR PLANS ARE 2X6 FRAME UNLESS NOTED OTHERWISE. ALL INTERIOR WALLS SHOWN ON FLOOR PLANS ARE 2X4 FRAME UNLESS NOTED OTHERWISE.
- ALL ANGLED WALLS SHOWN ON FLOOR PLANS ARE 45 UNLESS NOTED OTHERWISE.
- ALL WINDOWS SHALL HAVE A MINIMUM DPI RATING OF 25. BUILDER SHALL VERIFY WITH WINDOW MANUFACTURER THAT UNITS INSTALLED MEET THESE REQUIREMENTS AS PER N.C.S.R.B.C., 2018 EDITION, TABLE 301.2(4).
- ENERGY EFFICIENCY REQUIREMENTS FOR THE SPECIFIC CLIMATE ZONE WHERE STRUCTURE IS BEING BUILT SHALL BE IN ACCORDANCE WITH CHAPTER 11 OF THE N.C.S.R.B.C., 2018 EDITION, AS SHOWN IN SECTION N1101.2.

RESIDENTIAL BUILDING CODE SUMMARY

- PLANS ARE DESIGNED TO THE 2018 N.C.S.R.B.C.
- HOUSE IS DESIGNED FOR 115 MPH ULTIMATE DESIGN WIND SPEED (89 MPH NOMINAL DESIGN WIND SPEED), EXPOSURE B.
- ANCHOR BOLTS SHALL BE MIN. 1/2" DIAMETER AND SHALL EXTEND 7" MIN. INTO MASONRY OR CONCRETE. BOLTS TO BE NO MORE THAN 6' O.C. AND WITHIN 12" FROM THE CORNER.
- MEAN ROOF HEIGHT: 29'-3"
- COMPONENT & CLADDING DESIGNED FOR THE FOLLOWING LOADS:

MEAN ROOF HGT:	UP TO 30'	30'-1" TO 35'	35'-1" TO 40'	40'-1" TO 45'
ZONE 1	16.5,-18.0	17.3,-18.9	17.3,-18.9	17.3,-18.9
ZONE 2	16.5,-21.0	17.3,-22.1	17.3,-22.1	17.3,-22.1
ZONE 3	16.5,-21.0	17.3,-22.1	17.3,-22.1	17.3,-22.1
ZONE 4	18.0,-19.5	18.9,-20.5	18.9,-20.5	18.9,-20.5
ZONE 5	18.0,-24.1	18.9,-25.3	18.9,-25.3	18.9,-25.3
- MINIMUM VALUES FOR ENERGY COMPLIANCE: Zone 4
- MAXIMUM GLAZING U-FACTOR: .35
- INSULATING VALUES: CEILING: R-49 / WALLS: R-15 / FLOOR: R-19
 SLABS: R-10. CODE REFERENCE: TABLE N1102.1

AREA CALCULATIONS

HEATED (SQ. FT.)		UNHEATED (SQ. FT.)		UNFINISHED (SQ. FT.)	
BASEMENT:	N/A	GARAGE:	280	BASEMENT:	N/A
1ST FLOOR:	894	FRONT PORCH:	38	1ST FLOOR:	N/A
2ND FLOOR:	750	PATIO:	100	2ND FLOOR:	N/A
				ATTIC:	N/A
TOTAL:	1644	TOTAL:	418	TOTAL:	N/A

OVERALL DIMENSIONS

WIDTH: 43'-0"
 DEPTH: 54'-0"

FOUNDATION VENTILATION CALCULATIONS

(REFERENCE: N.C.S.R.B.C. 2018 EDITION SECTION R408)

NOT APPLICABLE WITH SLAB FOUNDATIONS

ATTIC VENTILATION REQUIREMENTS

NATURAL ROOF VENTILATION CALCULATIONS MECHANICAL ROOF VENTILATION CALCULATIONS

1212 SQ. FT. = 8.08 SQ. FT. VENT REQ'D
 150

BUILDER TO PROVIDE APPROPRIATE VENTILATING AS REQUIRED PER CODE

1212 SQ. FT. = 4.04 SQ. FT. VENT REQ'D
 300

BUILDER TO PROVIDE APPROPRIATE VENTILATING AS REQUIRED PER CODE

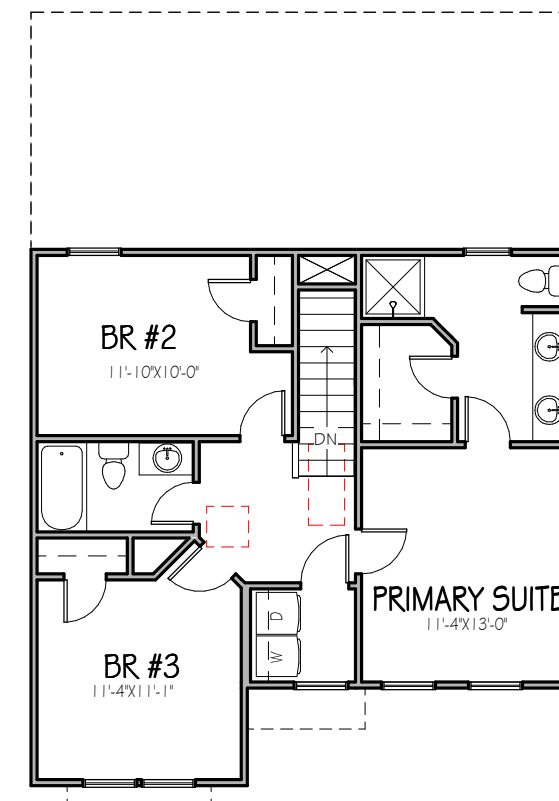
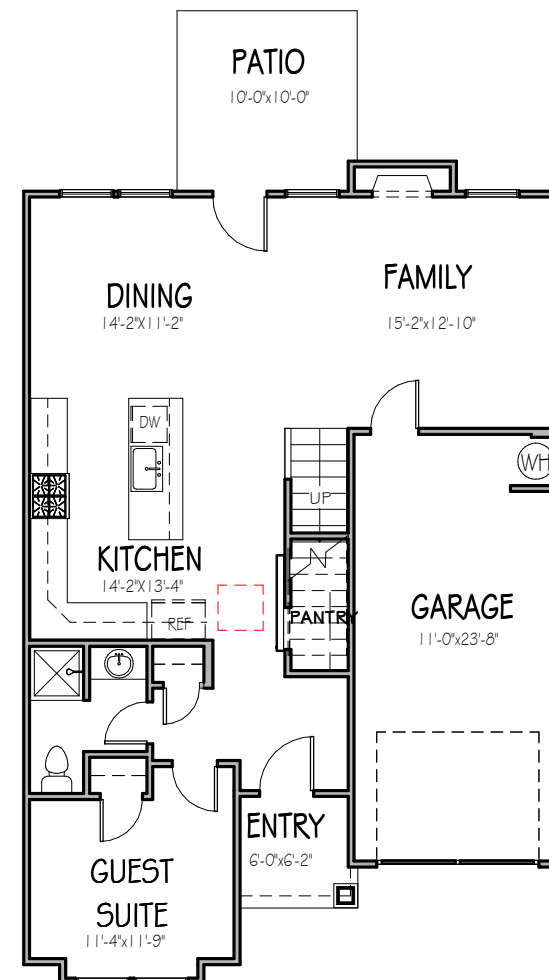

MATERIALS LEGEND

	EARTH/COMPACT FILL		FINISH WOOD
	CONCRETE		ROUGH WOOD
	BRICK		BLOCKING
	CONCRETE BLOCK/STONE		PLYWOOD
	STEEL		BATT INSULATION
	ALUMINUM		RIGID INSULATION

TOILET ACCESSORIES LEGEND

PROVIDE 2X4 BLOCKING IN THE WALL FOR THE FOLLOWING:

TB	TOWEL BAR
TP	TOILET PAPER HOLDER
TR	TOWEL RING
MC	MEDICINE CABINET
MR	MAGAZINE RACK

FORGET ME NOT
SER ELEVATION A
LOT 0252 SERENITY

Drawn By	MMH
Checked By	JM
Date Drawn	2/16/20
Revision Date	7/1/20
	4/5/22
	11/22/22
	2/21/23

Sheet

C

1

2

THE PURPOSE OF THESE DRAWINGS IS TO SHOW THE INTENT OF THE DESIGN AND CONSTRUCTION OF THIS HOME. CONTRACTOR SHOULD VERIFY ALL CONDITIONS AND DIMENSIONS PRIOR TO CONSTRUCTION. ONCE A PERMIT HAS BEEN ISSUED, CONTRACTOR SHALL ASSUME ALL RESPONSIBILITY TO THE ACCURACY OF THE PLANS AND ANY CHANGES MADE DURING CONSTRUCTION.



This document is property of Garman Homes Inc, and was prepared for their use only. The plans, elevations, illustrations, and other material contained within this set may not be reproduced, either in part or wholly, in any manner without the express written permission of Garman Homes, Inc. All right reserved and protected under federal law.

Project Number	Project Number
Plan Number	FP-1644

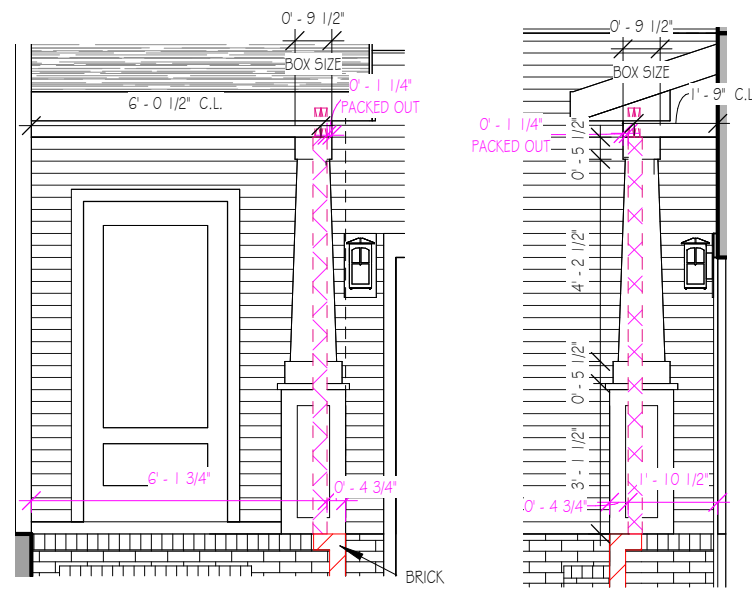

COLUMN DETAILS

1/4" = 1'-0"

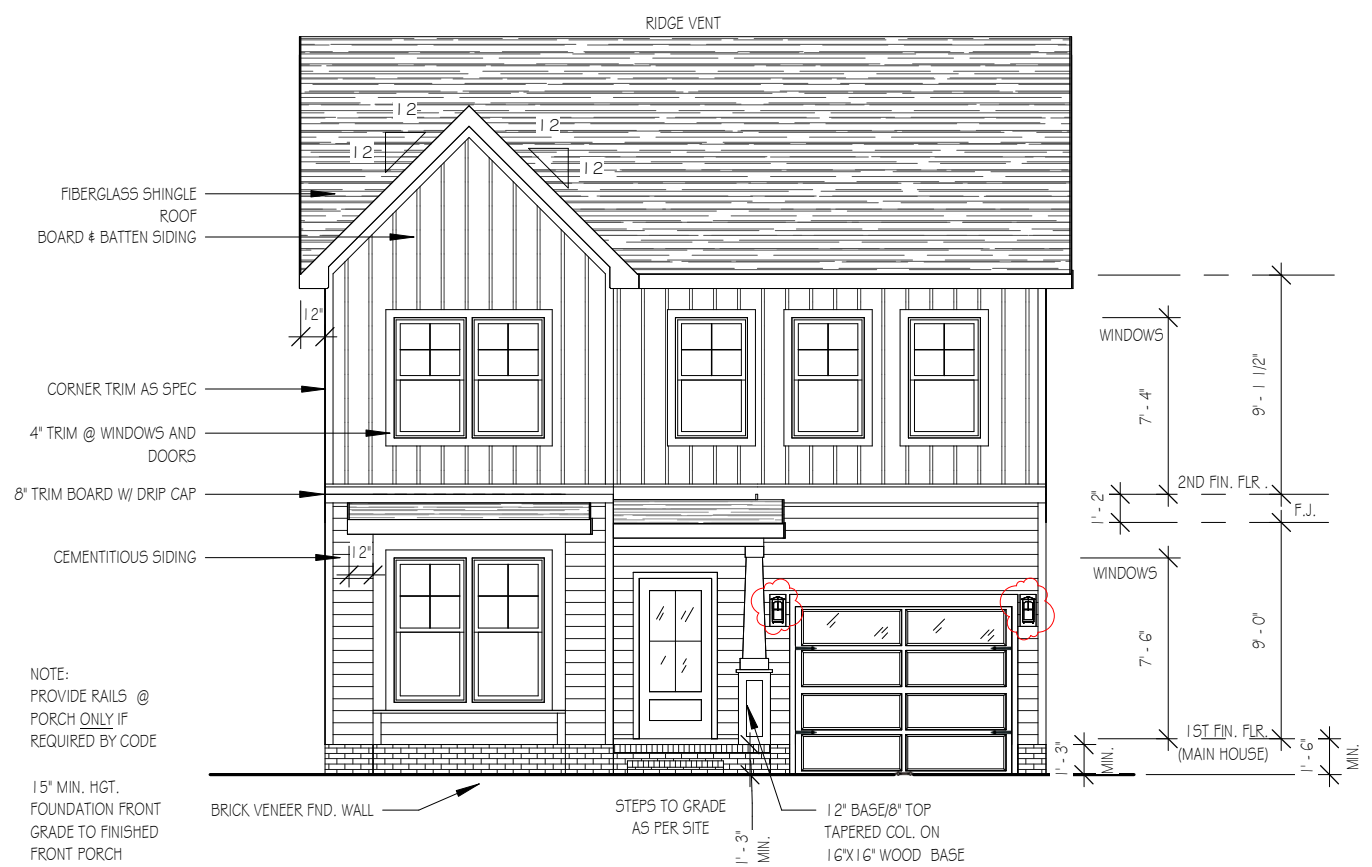

FRONT ELEVATION

1/8" = 1'-0"

NOTE - SLOPE ALL GRADES AWAY FROM HOUSE FOR POSITIVE DRAINAGE

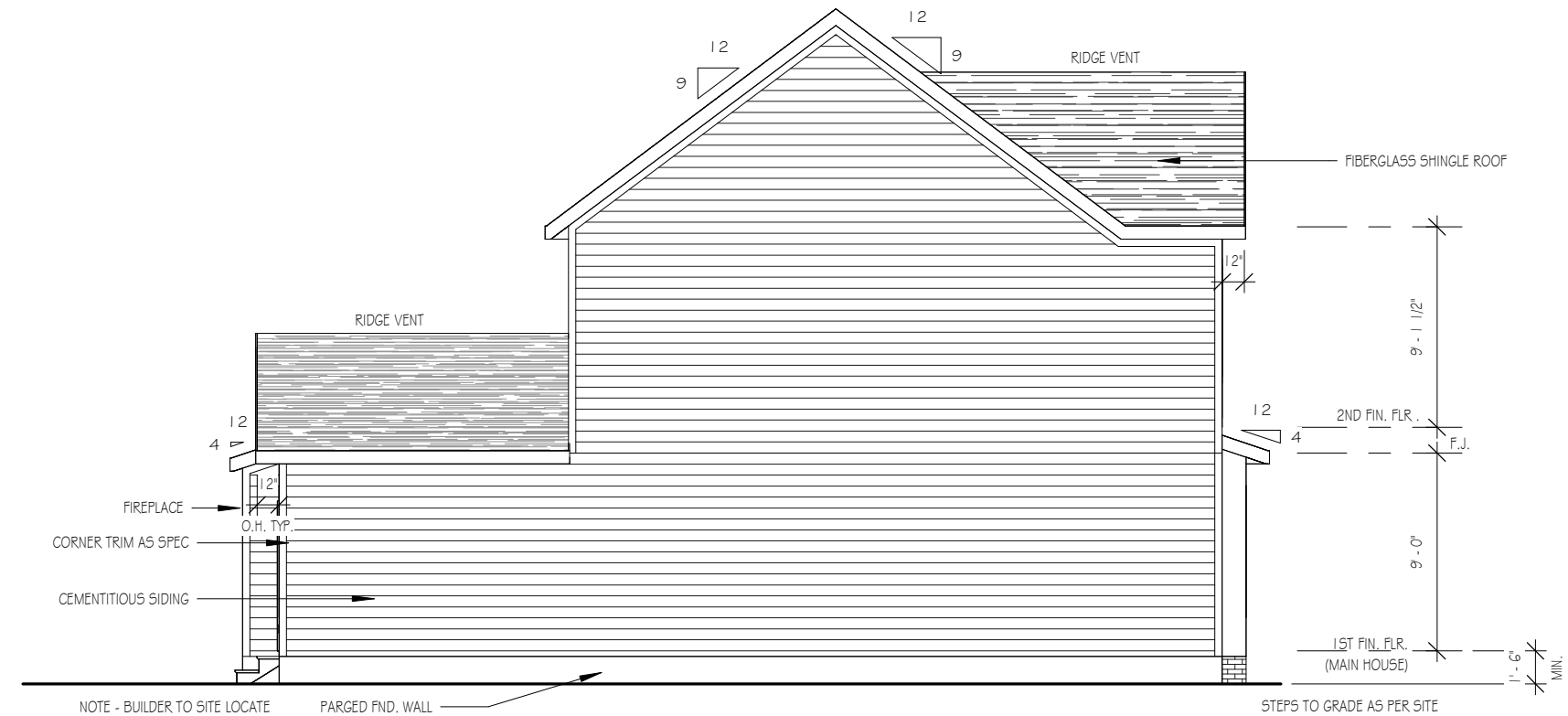

LEFT SIDE ELEVATION

1/8" = 1'-0"

WINDOWS WITH CORNER LOTS ONLY

FORGET ME NOT
 SER ELEVATION A
 LOT 0252 SERENITY

Drawn By	MH
Checked By	CM
Date Drawn	4/8/20
Revision Date	7/1/20 4/5/22 2/21/23

Sheet

THE PURPOSE OF THESE DRAWINGS IS TO SHOW THE INTENT OF THE DESIGN AND CONSTRUCTION OF THIS HOME. CONTRACTOR SHOULD VERIFY ALL CONDITIONS AND DIMENSIONS PRIOR TO CONSTRUCTION. ONCE A PERMIT HAS BEEN ISSUED, CONTRACTOR SHALL ASSUME ALL RESPONSIBILITY TO THE ACCURACY OF THE PLANS AND ANY CHANGES MADE DURING CONSTRUCTION.



This document is property of Garman Homes Inc, and was prepared for their use only. The plans, elevations, illustrations, and other material contained within this set may not be reproduced, either in part or wholly, in any manner without the express written permission of Garman Homes, Inc. All right reserved and protected under federal law.

Project Number	Project Number
Plan Number	FP-1644

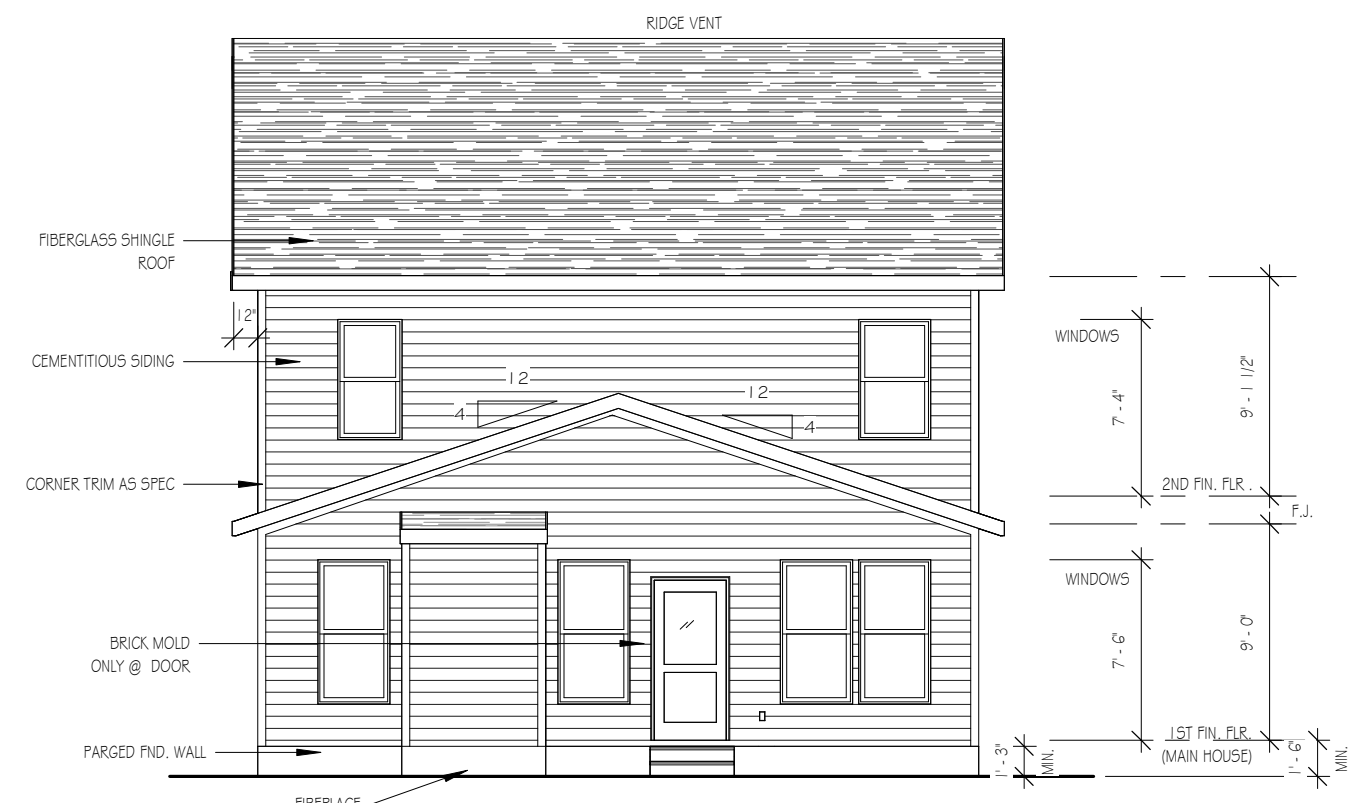

REAR ELEVATION

1/8" = 1'-0"

NOTE - BUILDER TO SITE LOCATE DECK STEPS AS PER GRADE

NOTE - SLOPE ALL GRADES AWAY FROM HOUSE FOR POSITIVE DRAINAGE

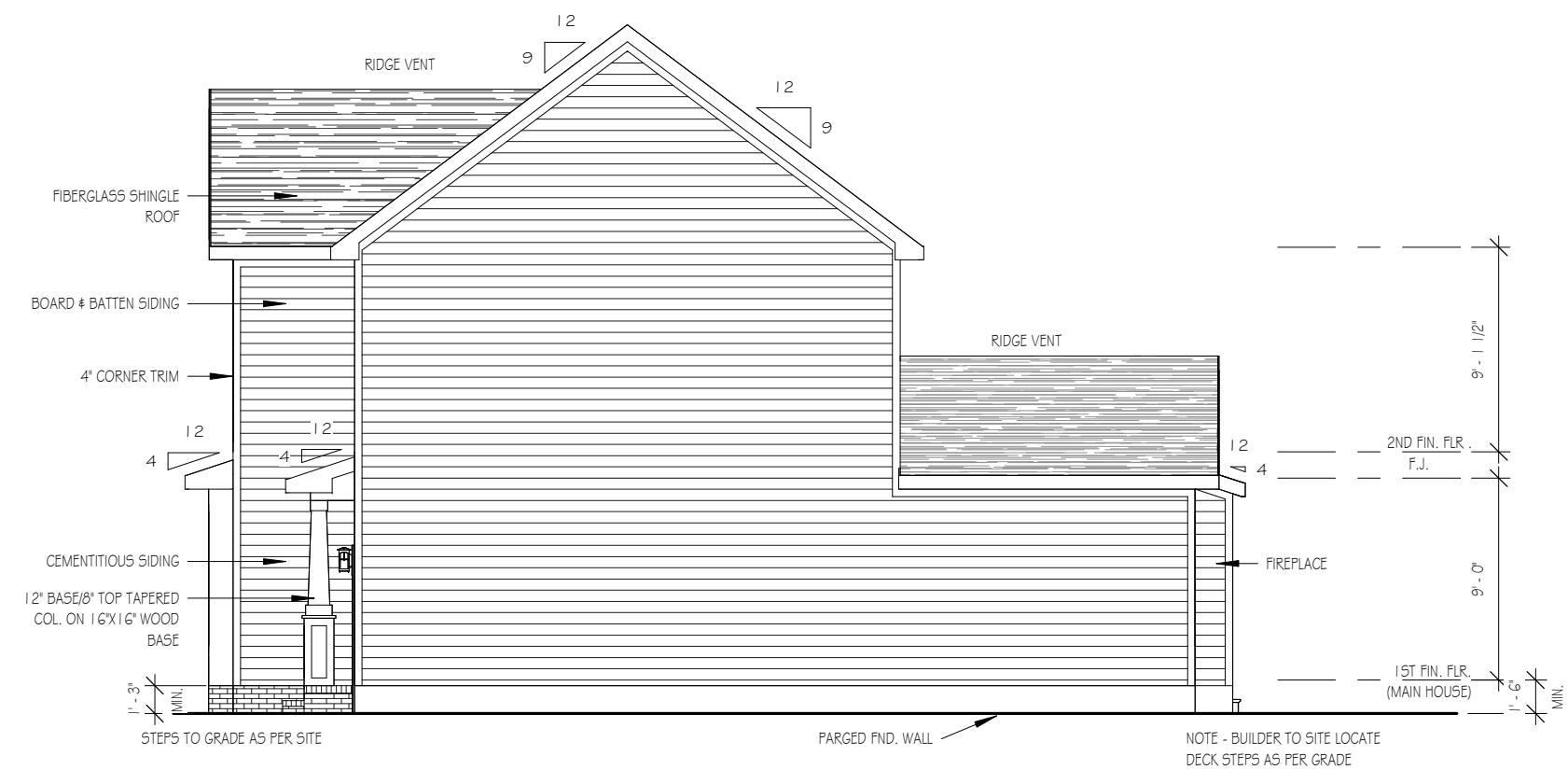

RIGHT SIDE ELEVATION

1/8" = 1'-0"

WINDOWS WITH CORNER LOTS ONLY

NOTE: PROVIDE RAILS @ PORCH ONLY IF REQUIRED BY CODE

15" MIN. HGT. FOUNDATION FRONT GRADE TO FINISHED FRONT PORCH

NOTE - BUILDER TO SITE LOCATE DECK STEPS AS PER GRADE

FORGET ME NOT
 SER ELEVATION A
 LOT 0252 SERENITY

Drawn By	MH
Checked By	CM
Date Drawn	4/8/20
Revision Date	7/1/20
	4/5/22
	2/21/23

Sheet

THE PURPOSE OF THESE DRAWINGS IS TO SHOW THE INTENT OF THE DESIGN AND CONSTRUCTION OF THIS HOME. CONTRACTOR SHOULD VERIFY ALL CONDITIONS AND DIMENSIONS PRIOR TO CONSTRUCTION. ONCE A PERMIT HAS BEEN ISSUED, CONTRACTOR SHALL ASSUME ALL RESPONSIBILITY TO THE ACCURACY OF THE PLANS AND ANY CHANGES MADE DURING CONSTRUCTION.



This document is property of Garman Homes Inc, and was prepared for their use only. The plans, elevations, illustrations, and other material contained within this set may not be reproduced, either in part or wholly, in any manner without the express written permission of Garman Homes, Inc. All right reserved and protected under federal law.

Project Number	Project Number
Plan Number	FP-1644

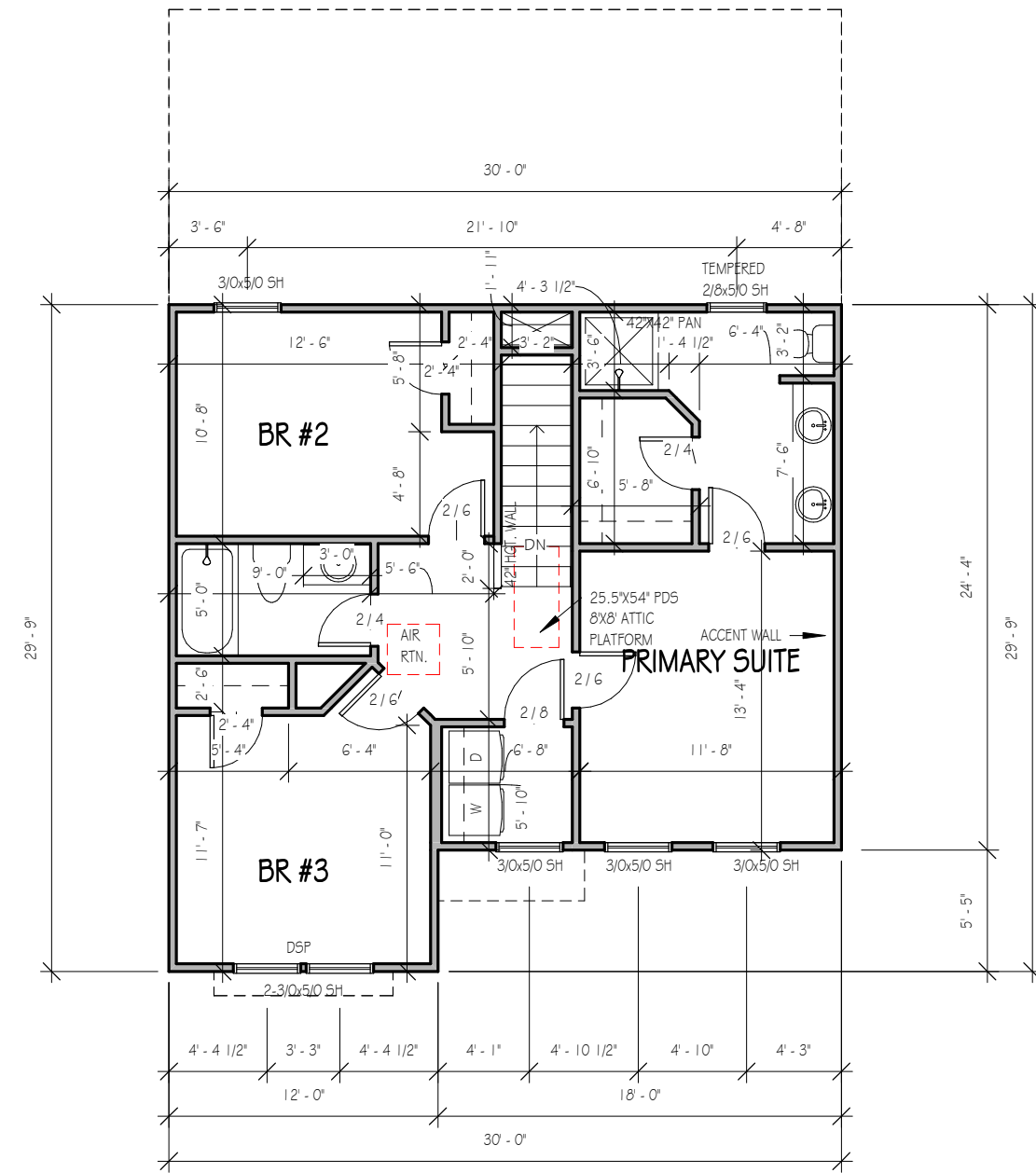

NOTES:
 ROUGH FRAME ALL CASED OPENINGS 2" BIGGER THAN FINISHED OPENING CALLS FOR
 ROUGH FRAME ALL WINDOW OPENINGS 1/2" LARGER THAN FINISHED WINDOW CALLS FOR, WHEN PAIRED WITH ANOTHER WINDOW THAT CALLS FOR DSP, ADD EXTRA TO OUTSIDE MEASUREMENT OF WINDOW
 FRAME ALL INTERIOR DOOR HEADERS AT 84" A.F.F.
 ALL EXTERIOR WALLS 2X4
 TOP OF ALL WINDOWS SILLS SHALL BE 24" MINIMUM ABOVE THE FINISHED FLOOR OR A FALL PREVENTION DEVICE SHALL BE INSTALLED IN ACCORDANCE WITH SECTION R312.2 OF N.C.S.R.B.C., 2018 EDITION

SECOND FLOOR

1/8" = 1'-0"

9'-0" CLG. HGT. U.N.O.
 SET WINDOWS @ 7'-4" U.N.O.

FORGET ME NOT
 SER ELEVATION A
 LOT 0252 SERENITY

Drawn By	MH
Checked By	CM
Date Drawn	4/8/20
Revision Date	7/1/20 4/5/22 2/21/23

Sheet

THE PURPOSE OF THESE DRAWINGS IS TO SHOW THE INTENT OF THE DESIGN AND CONSTRUCTION OF THIS HOME. CONTRACTOR SHOULD VERIFY ALL CONDITIONS AND DIMENSIONS PRIOR TO CONSTRUCTION. ONCE A PERMIT HAS BEEN ISSUED, CONTRACTOR SHALL ASSUME ALL RESPONSIBILITY TO THE ACCURACY OF THE PLANS AND ANY CHANGES MADE DURING CONSTRUCTION.



This document is property of Garman Homes Inc, and was prepared for their use only. The plans, elevations, illustrations, and other material contained within this set may not be reproduced, either in part or wholly, in any manner without the express written permission of Garman Homes, Inc. All right reserved and protected under federal law.

Project Number	Project Number
Plan Number	FP-1644

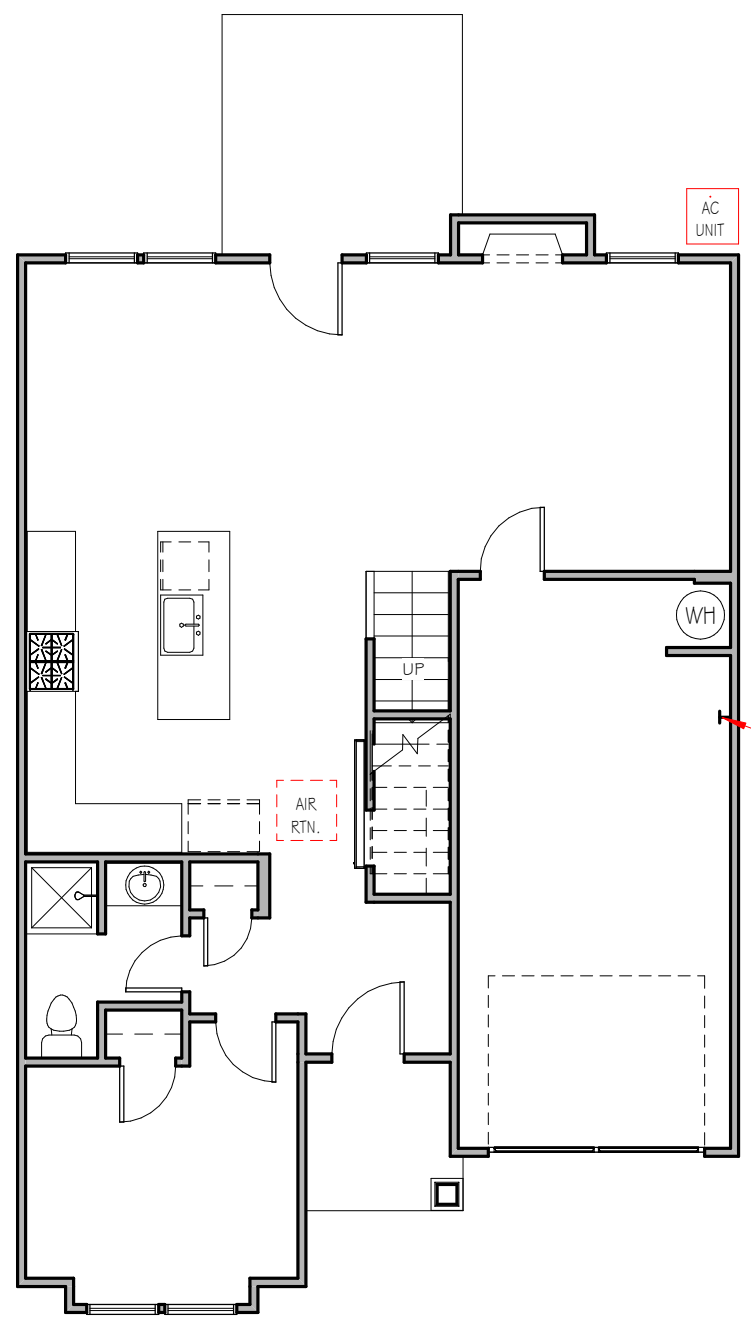

FIRST FLOOR MECHANICAL PAGE

1/8" = 1'-0"

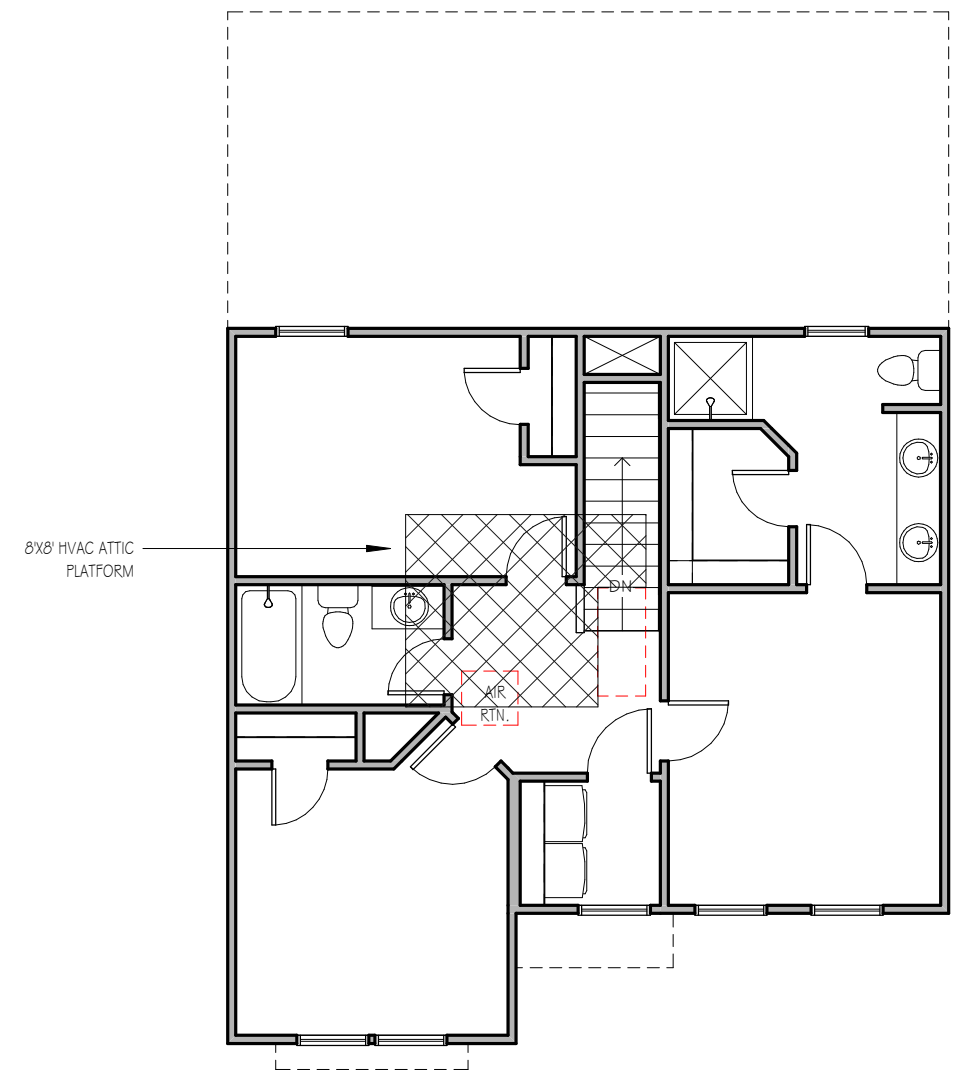

SECOND FLOOR MECHANICAL PAGE

1/8" = 1'-0"

FORGET ME NOT
 SER ELEVATION A
 LOT 0252 SERENITY

Drawn By	MH
Checked By	CM
Date Drawn	4/8/20
Revision Date	7/1/20
	4/5/22
	2/21/23

Sheet

M

THE PURPOSE OF THESE DRAWINGS IS TO SHOW THE INTENT OF THE DESIGN AND CONSTRUCTION OF THIS HOME. CONTRACTOR SHOULD VERIFY ALL CONDITIONS AND DIMENSIONS PRIOR TO CONSTRUCTION. ONCE A PERMIT HAS BEEN ISSUED, CONTRACTOR SHALL ASSUME ALL RESPONSIBILITY TO THE ACCURACY OF THE PLANS AND ANY CHANGES MADE DURING CONSTRUCTION.



This document is property of Garman Homes Inc, and was prepared for their use only. The plans, elevations, illustrations, and other material contained within this set may not be reproduced, either in part or wholly, in any manner without the express written permission of Garman Homes, Inc. All right reserved and protected under federal law.

Project Number	Project Number
Plan Number	FP-1644

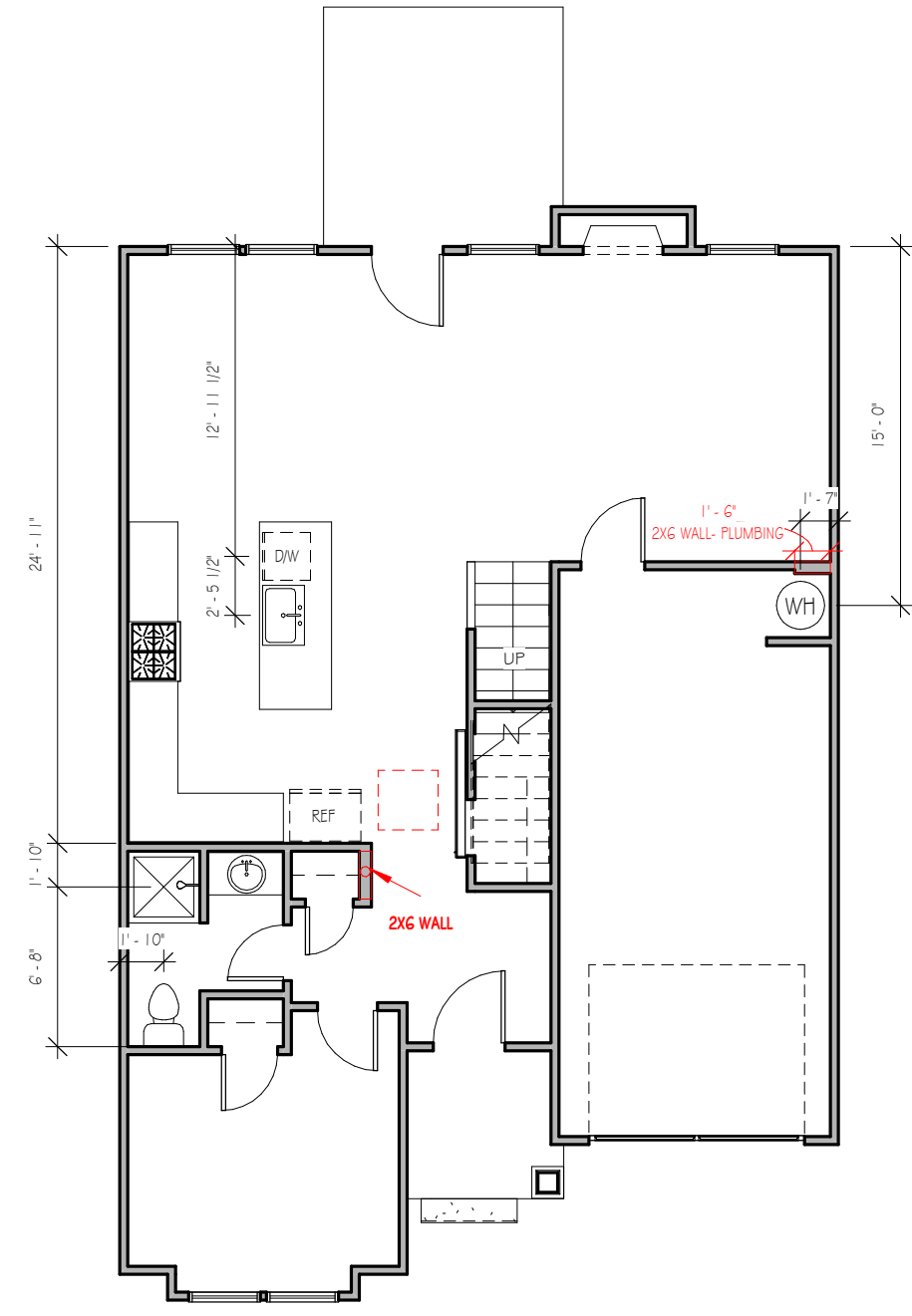

FIRST FLOOR PLUMBING

1/8" = 1'-0"

FORGET ME NOT
 SER ELEVATION A
 LOT 0252 SERENITY

Drawn By	MH
Checked By	CM
Date Drawn	4/8/20
Revision Date	7/1/20
	4/5/22
	2/21/23

Sheet

P

THE PURPOSE OF THESE DRAWINGS IS TO SHOW THE INTENT OF THE DESIGN AND CONSTRUCTION OF THIS HOME. CONTRACTOR SHOULD VERIFY ALL CONDITIONS AND DIMENSIONS PRIOR TO CONSTRUCTION. ONCE A PERMIT HAS BEEN ISSUED, CONTRACTOR SHALL ASSUME ALL RESPONSIBILITY TO THE ACCURACY OF THE PLANS AND ANY CHANGES MADE DURING CONSTRUCTION.



This document is property of Garman Homes Inc. and was prepared for their use only. The plans, elevations, illustrations, and other material contained within this set may not be reproduced, either in part or wholly, in any manner without the express written permission of Garman Homes, Inc. All right reserved and protected under federal law.

Project Number _____
 Project Number _____
 Plan Number _____

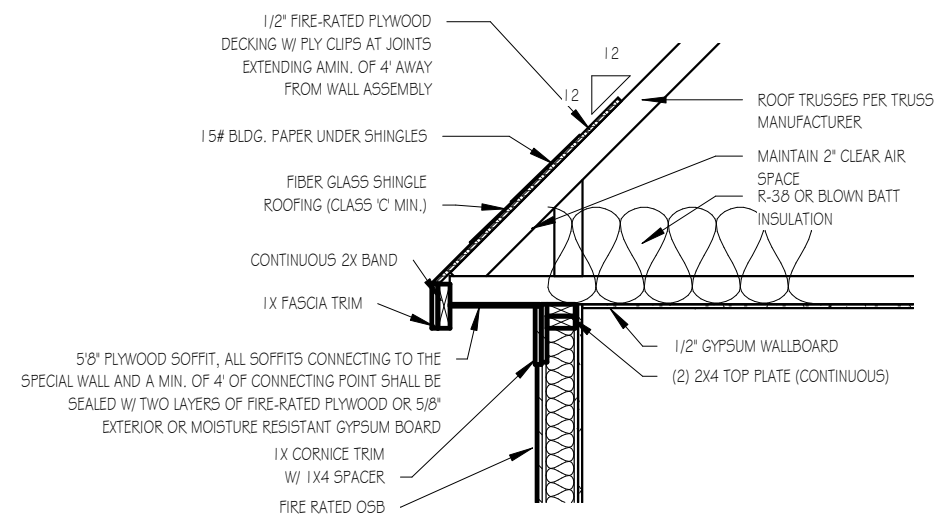
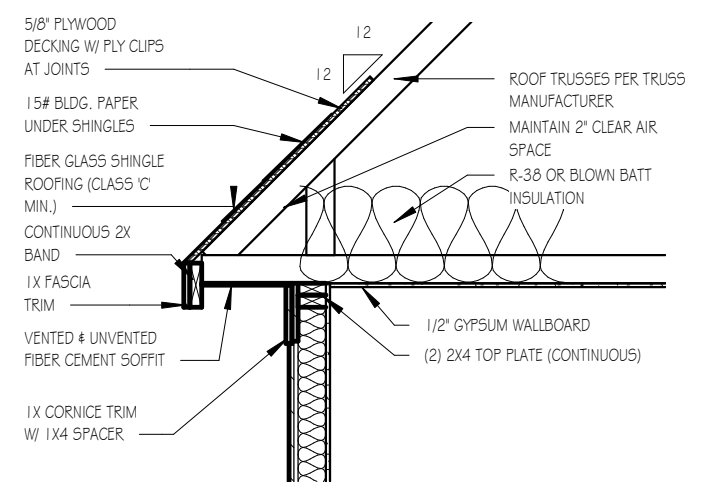

ROOF DETAIL SPECIAL FIRE-RATED WALLS

1/2" = 1'-0"

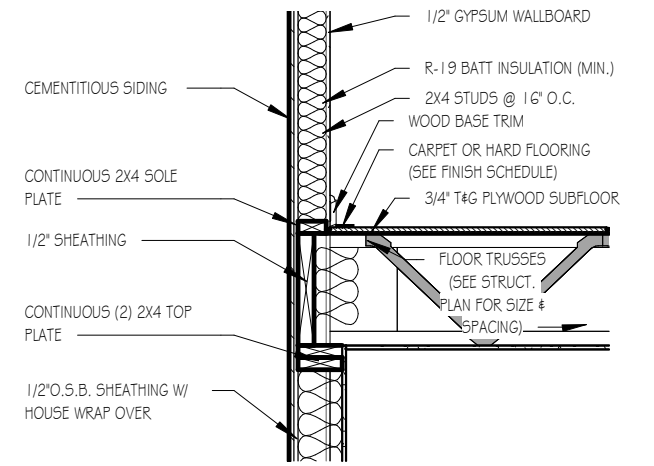

TWO-STORY WALL SECTION

1/2" = 1'-0"

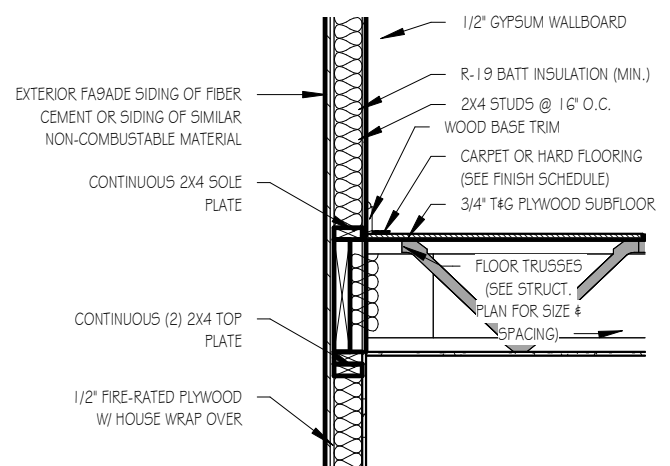

SECOND FLOOR SECTION - SPECIAL FIRE-RATED WALLS

1/2" = 1'-0"

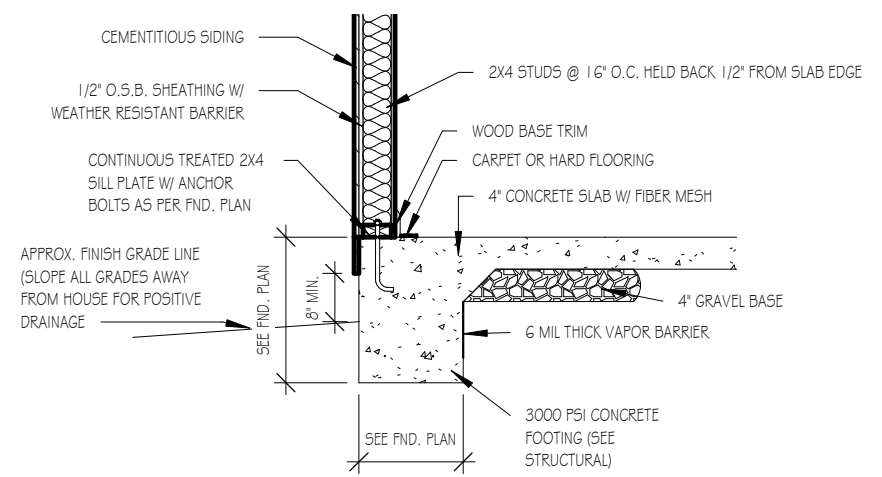

FOUNDATION DETAIL - SLAB

1/2" = 1'-0"

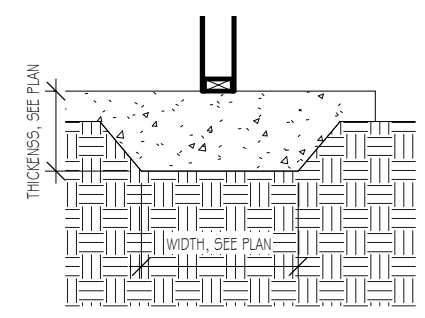

LUG FOOTING

1/2" = 1'-0"

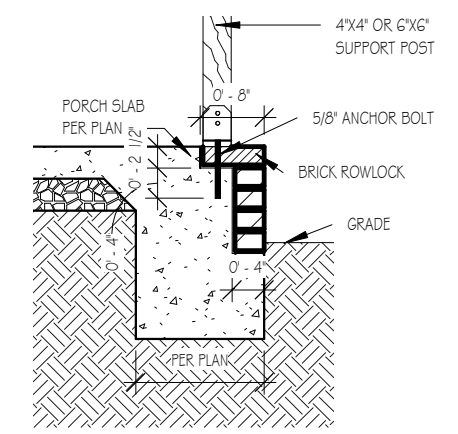

FRONT PORCH COLUMNS SUPPORT ATTACHMENT

1/2" = 1'-0"

TYPICAL DETAIL SHEET
 SERENITY COLLECTION

Drawn By	MMH
Checked By	JM
Date Drawn	10/28/20
Revision Date	9/14/22
	9/20/22

Sheet

D

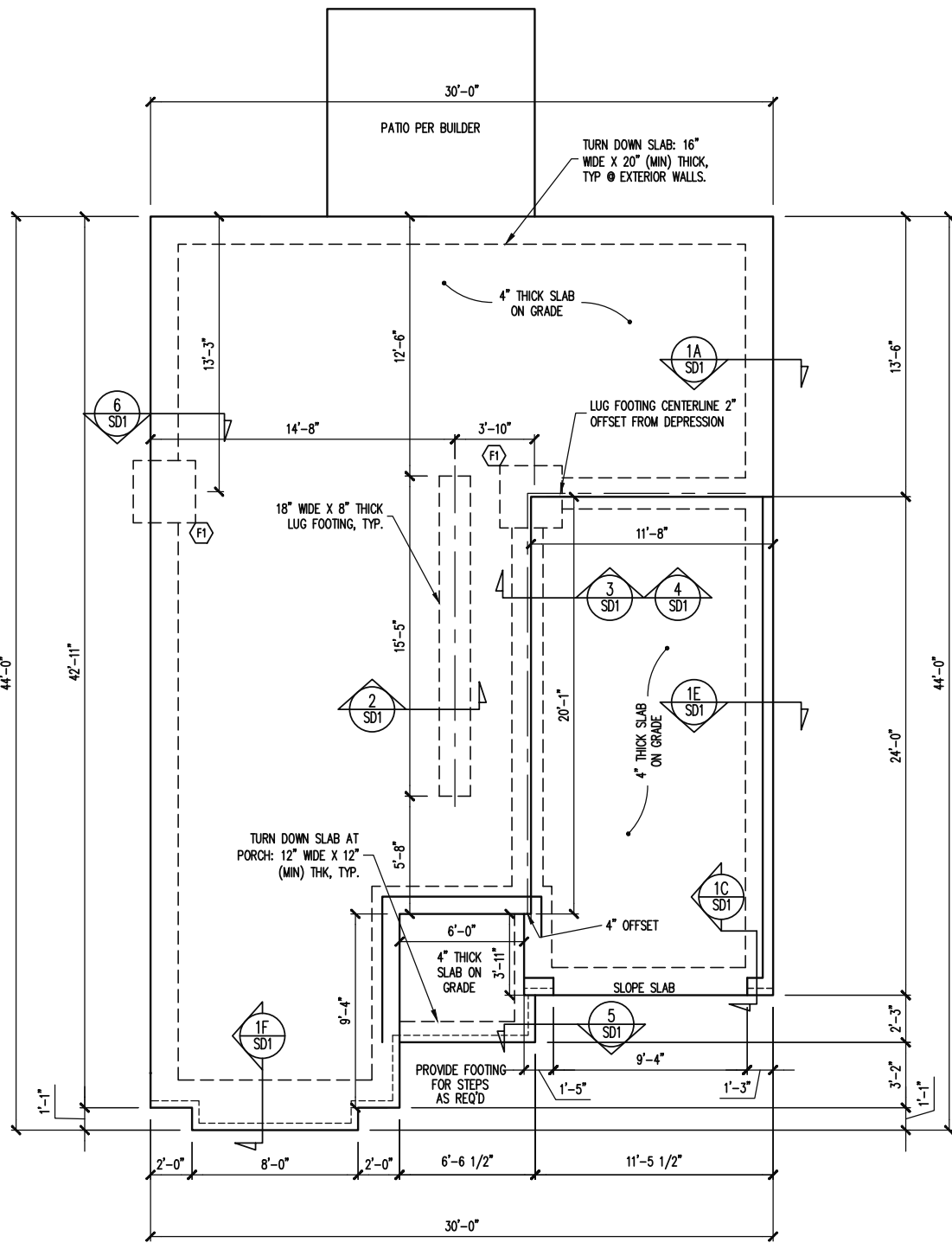

FOUNDATION PLAN
ELEVATION A

1/8" = 1'-0"

GUEST SUITE
OPTION- SEE
ARCH SET

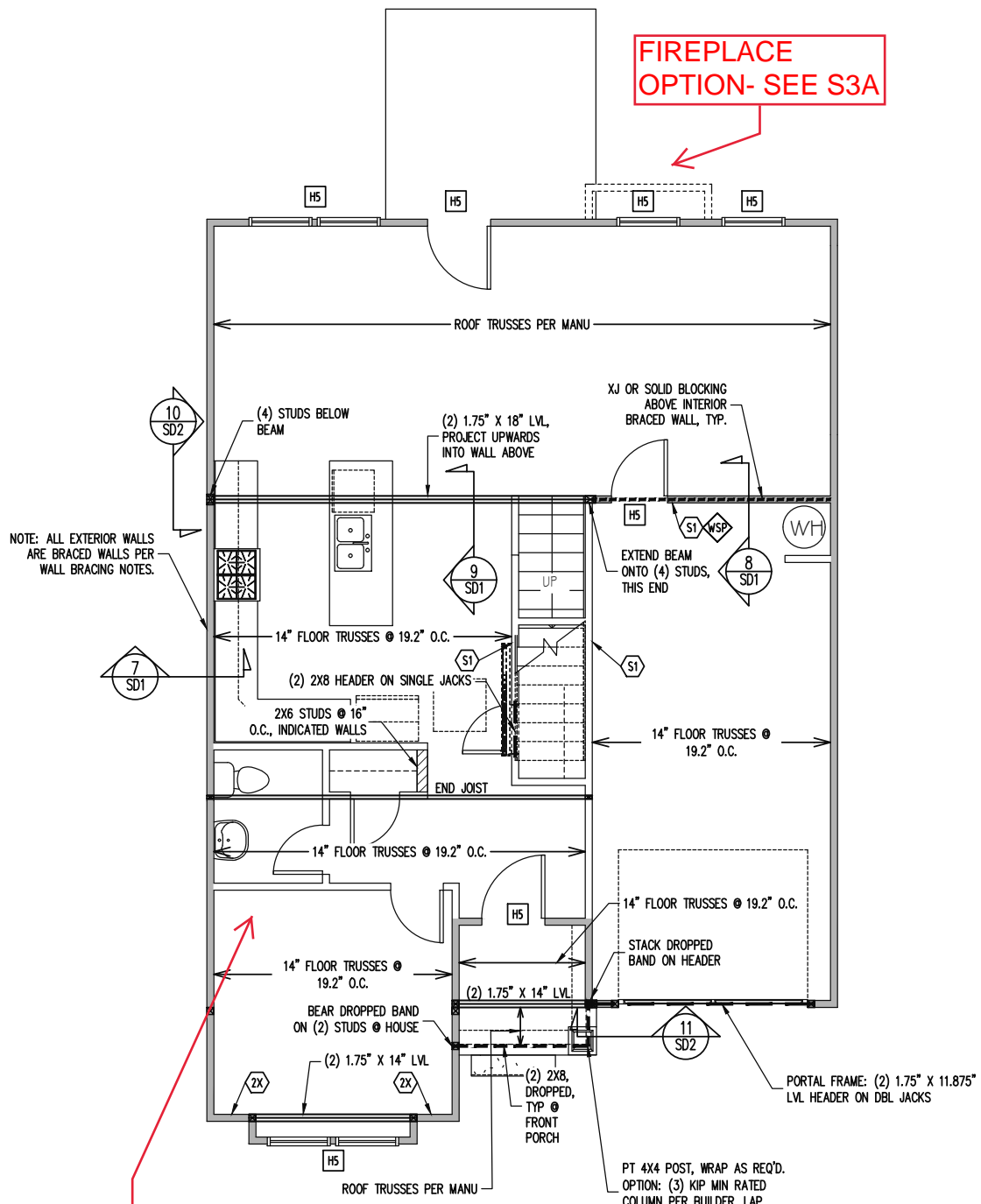

1ST FLOOR FRAMING PLAN

ELEVATION A

WALLS AND CEILING
1/8" = 1'-0"

FRAMING SCHEDULE

S1 INTERIOR LOAD BEARING WALL: SECURE TO THICKENED SLAB BELOW WITH 1/2" RED HEADER ANCHOR (OR EQUAL) @ 6'-0" O.C., 12" MAX FROM ENDS / CORNERS OF WALL, 7" MIN EMBEDMENT INTO SLAB BELOW.

JOIST SUBSTITUTION

14" FLOOR TRUSSES PERMITTED TO BE SUBSTITUTED WITH 14" I-JOISTS.

MAINTAIN MINIMUM SPACING AS CALLED OUT ON PLANS.

SIMP. IUS/ITS3.56/14 HANGERS TO BE SUBSTITUTED WITH SIMP. IUS/ITS2.06/14 HANGER WHEN I-JOISTS HAVE BEEN INSTALLED.

CONSTRUCTION SPECIFICATIONS

INSTANT REFERENCES

REFER TO THE CONSTRUCTION SPECIFICATIONS SECTIONS FOR THE FOLLOWING INFORMATION:

PART 1.01: CURRENT GOVERNING CODE

PART 14: STUD SUPPORT FOR BEAMS

PART 17: KING STUDS FOR EXTERIOR WALLS

SEE DETAIL / CONSTRUCTION SPECIFICATIONS SHEETS FOR I-JOISTS ALLOWABLE SUBSTITUTIONS

WALL BRACING

SHADED WALLS:

ALL EXTERIOR STUD WALLS, EXTERIOR SIDE, ARE TO BE CONTINUOUSLY SHEATHED WITH 7/16 APA RATED OSB NAILED TO STUDS WITH 8d NAILS @ 6" O.C. AT PANEL EDGES, 12" O.C. IN PANEL FIELD.

WSP - ONE SIDE OF INTERIOR WALL OR INSIDE OF EXTERIOR WALL WITH 3/8" MIN. THICKNESS WOOD STRUCTURAL PANELING. ATTACH WSP TO STUD WALL WITH 8d NAILS @ 4" O.C. AT PANEL EDGES, 8" O.C. IN PANEL FIELD.

2X - SHEATH BOTH SIDES OF STUD WALL WITH 7/16 APA RATED OSB, NAILED TO STUDS WITH 8d NAILS @ 6" O.C. AT PANEL EDGES, 12" O.C. IN PANEL FIELD.

NOTES:
PROVIDED CONTINUOUS SHEATHING = 155' MIN.

REFERENCE PART 16.02 OF CONSTRUCTION SPECIFICATIONS FOR GENERAL WIND BRACING INFORMATION.

HEADER SCHEDULE

- H1 SINGLE 2X4 TURNED FLAT (A)
- H2 (2) 2X4'S ON SINGLE JACKS (B)
- H3 (2) 2X10'S ON SINGLE JACKS (C)
- H4 (2) 1.75" X 9.25" LVL'S ON DBL JACKS
- H5 (2) 2X8'S ON SINGLE JACKS

(A) TYPICAL FOR INTERIOR NON LOAD BEARING WALLS ONLY, ROUGH OPENING 38" MAX.

(B) TYPICAL FOR INTERIOR NON LOAD BEARING WALLS ONLY, ROUGH OPNG 38" TO 74" MAX.

(C) TYPICAL FOR ALL CONDITIONS NOT LISTED IN (A) OR (B) UNO.

NOTES:
-HEADERS IN NON LOAD BEARING INTERIOR WALLS ARE NOT LABELED.

FOUNDATION SCHEDULE

F1 ENLARGE FOOTING TO 36" SQ. X 12" THK

NOTES:
-HEIGHT AND BACKFILL LIMITATIONS FOR FOUNDATION WALLS ARE TO BE GOVERNED BY THE NCSBC, LATEST EDITION.

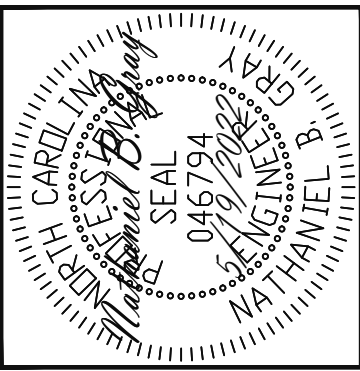

ENGINEERING SEAL VALID FOR 1 YEAR ONLY.
The structural design of this plan is the property of Engineering Tech Associates, P.A. These plans are for the client listed only. Engineering Tech Associates, P.A. assumes no liability for these plans if construction or permitting takes place more than 1 year after the seal date without written permission from Engineering Tech Associates, P.A.

STRUCTURAL ENGINEERS
License No. C-3870
318 W Millbrook Rd, Suite 201
Raleigh, North Carolina 27609
Phone (919) 844-1661

FRESH PAINT	REV 1 9/2/2022
STRUCTURAL ADDENDUM	REV 2 11/28/2022
SCOPE	TBD
LOC	MASTER
PLAN:	FORGET ME NOT

ENG: NBG/CMC
DATE: 5/19/2022

PROJECT NO.
22-30-060

SHEET NO.
S1A

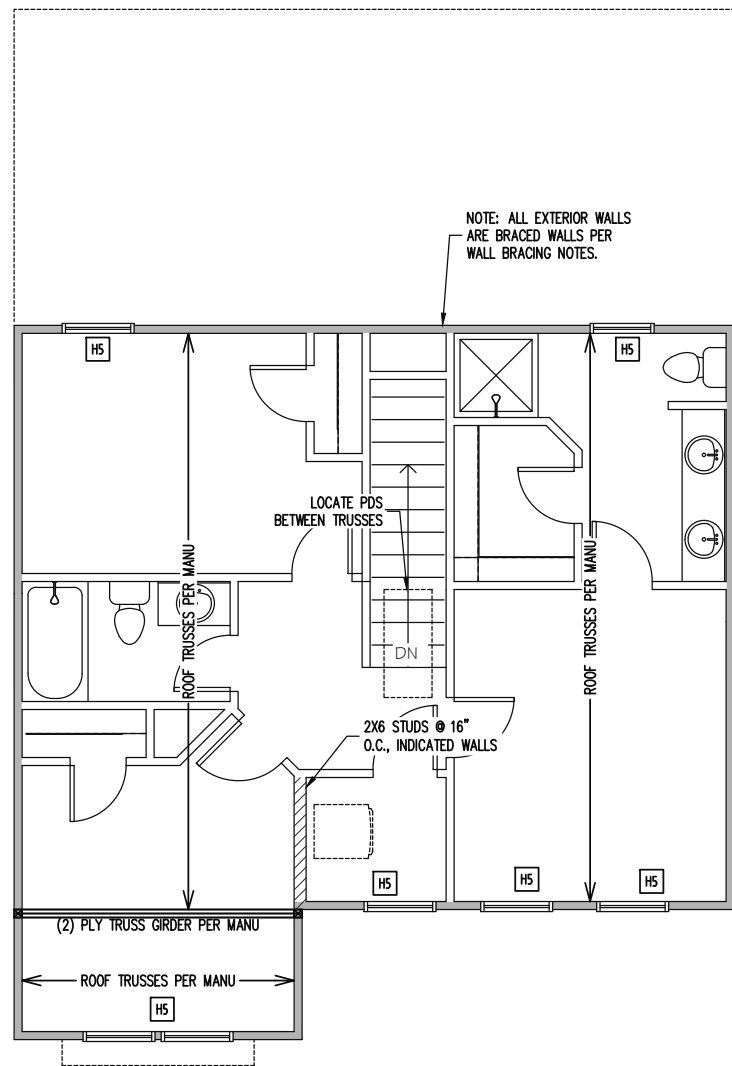

NOTE: ALL EXTERIOR WALLS ARE BRACED WALLS PER WALL BRACING NOTES.

NOTE: ALL EXTERIOR GABLE END WALLS ARE CONTINUOUSLY SHEATHED BRACED WALLS PER WALL BRACING NOTES.

2ND FLOOR FRAMING PLAN
ELEVATION A
WALLS AND CEILING
1/8" = 1'-0"

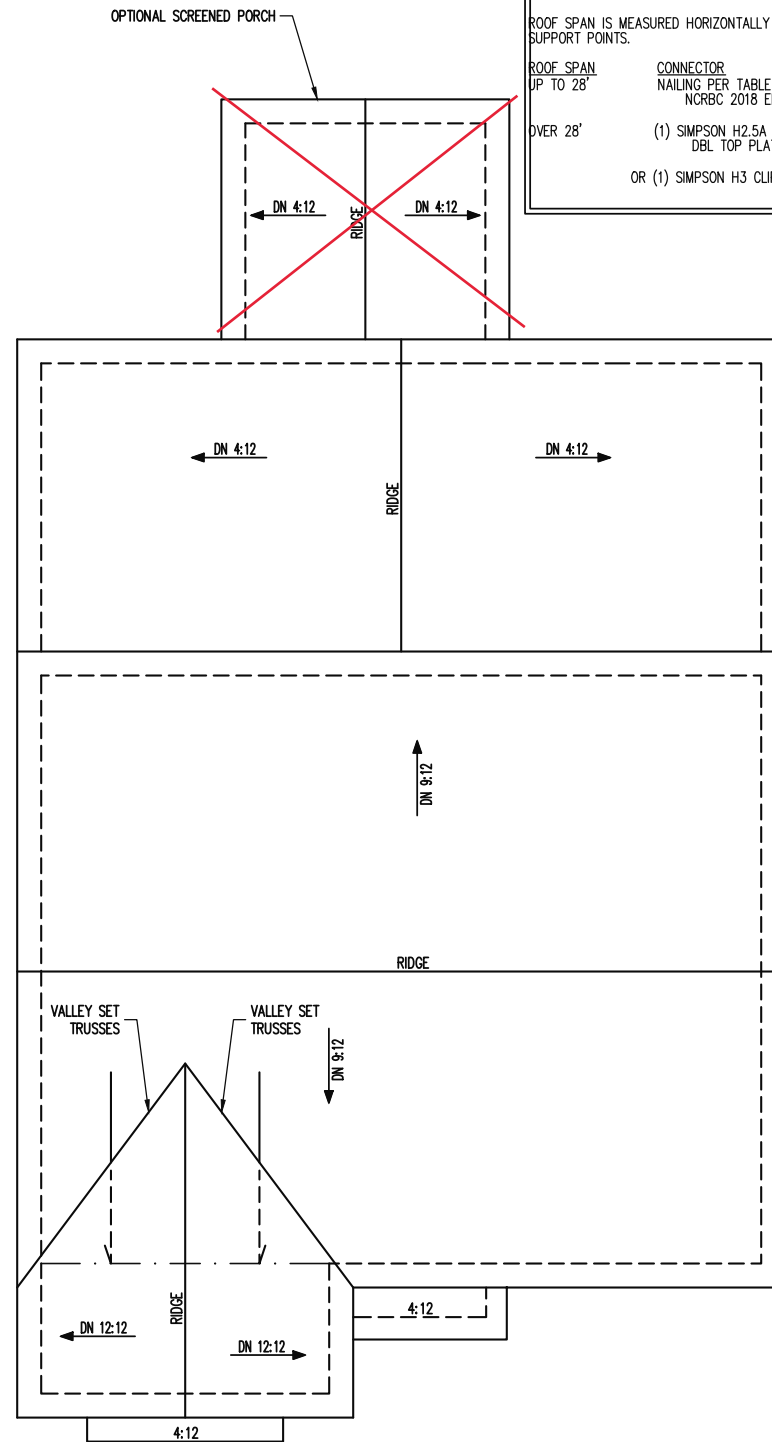

TRUSS UPLIFT CONNECTORS
EXPOSURE B, 120 MPH, ANY PITCH, 24" O.C. MAX ROOF TRUSS SPACING

TRUSSES SHALL BE ATTACHED TO SUPPORT WALL FOR UPLIFT RESISTANCE. CONTINUOUS OSB WALL SHEATHING BELOW PROVIDES CONTINUOUS UPLIFT RESISTANCE TO FOUNDATION. ALL TRUSSES SUPPORTED BY INTERMEDIATE SUPPORT WALLS, KNEEWALLS OR BEAMS SHALL BE ATTACHED TO SUPPORTING MEMBER PER SCHEDULE BELOW.

ROOF SPAN IS MEASURED HORIZONTALLY BETWEEN FURTHEST SUPPORT POINTS.

ROOF SPAN	CONNECTOR
UP TO 28'	NAILING PER TABLE 602.3(1) NCRBC 2018 EDITION
OVER 28'	(1) SIMPSON H2.5A HURRICANE CLIP TO DBL TOP PLATE OR BEAM OR (1) SIMPSON H3 CLIP TO SINGLE 2X4 PLATE

ROOF FRAMING PLAN
ELEVATION A
1/8" = 1'-0"

FRAMING NOTES

ROOF ONLY
-ROOF TRUSSES PER MANU. TYPICAL U.N.O.
-VERIFY ALL KNEEWALL HEIGHTS, ROOF PITCHES, AND ARCHITECTURAL OVERHANGS PRIOR TO CONSTRUCTION

CONSTRUCTION SPECIFICATIONS
INSTANT REFERENCES

REFER TO THE CONSTRUCTION SPECIFICATIONS SECTIONS FOR THE FOLLOWING INFORMATION:
PART 1.01: CURRENT GOVERNING CODE
PART 14: STUD SUPPORT FOR BEAMS
PART 17: KING STUDS FOR EXTERIOR WALLS

WALL BRACING

SHADED WALLS:
ALL EXTERIOR STUD WALLS, EXTERIOR SIDE, ARE TO BE CONTINUOUSLY SHEATHED WITH 7/16 APA RATED OSB NAILED TO STUDS WITH 8d NAILS @ 6" O.C. AT PANEL EDGES, 12" O.C. IN PANEL FIELD.

NOTES:
PROVIDED CONTINUOUS SHEATHING = 119' MIN.
REFERENCE PART 16.02 OF CONSTRUCTION SPECIFICATIONS FOR GENERAL WIND BRACING INFORMATION.

HEADER SCHEDULE

- H1 SINGLE 2X4 TURNED FLAT (A)
 - H2 (2) 2X4'S ON SINGLE JACKS (B)
 - H3 (2) 2X10'S ON SINGLE JACKS (C)
 - H4 (2) 1.75" X 9.25" LVL'S ON DBL JACKS
 - H5 (2) 2X8'S ON SINGLE JACKS
- (A) TYPICAL FOR INTERIOR NON LOAD BEARING WALLS ONLY, ROUGH OPENING 38" MAX.
(B) TYPICAL FOR INTERIOR NON LOAD BEARING WALLS ONLY, ROUGH OPNG 38" TO 74" MAX.
(C) TYPICAL FOR ALL CONDITIONS NOT LISTED IN (A) OR (B) UNO.
- NOTES:
-HEADERS IN NON LOAD BEARING INTERIOR WALLS ARE NOT LABELED.

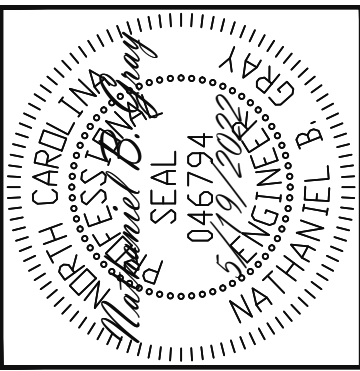

ENGINEERING SEAL VALID FOR 1 YEAR ONLY.
The structural design of this plan is the property of Engineering Tech Associates, P.A. These plans are for the client listed only. Engineering Tech Associates, P.A. assumes no liability for these plans if construction or permitting takes place more than 1 year after the seal date without written permission from Engineering Tech Associates, P.A.

Engineering Tech Associates, P.A.
STRUCTURAL ENGINEERS
License No. C-3870
318 W Millbrook Rd, Suite 201
Raleigh, North Carolina 27609
Phone (919) 844-1661

SCOPE	FRESH PAINT
LOC	STRUCTURAL ADDENDUM
PLAN	TBD
	MASTER
	FORGET ME NOT
REV 1	9/2/2022
REV 2	11/28/2022

ENG: NBG/CMC
DATE: 5/19/2022

PROJECT NO.
22-30-060

SHEET NO.
S2A

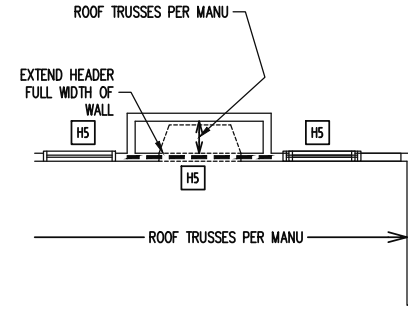

1ST FLOOR FRAMING PLAN
OPTIONAL FIREPLACE
1/8" = 1'-0"

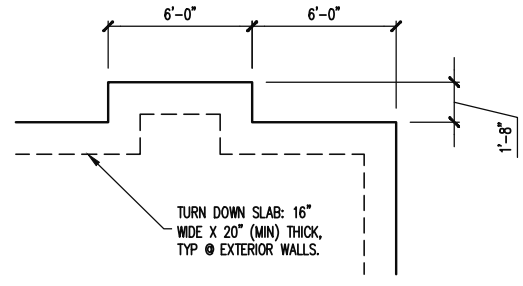

FOUNDATION PLAN
OPTIONAL FIREPLACE
1/8" = 1'-0"

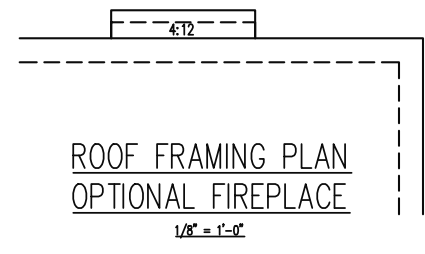

ROOF FRAMING PLAN
OPTIONAL FIREPLACE
1/8" = 1'-0"

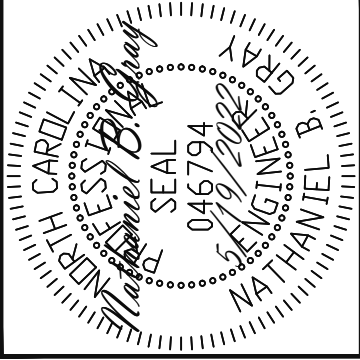

ENGINEERING SEAL VALID FOR 1 YEAR ONLY.
The structural design of this plan is the property of Engineering Tech Associates, P.A. These plans are for the client listed only. Engineering Tech Associates, P.A. assumes no liability for these plans if construction or permitting takes place more than 1 year after the seal date without written permission from Engineering Tech Associates, P.A.

Engineering Tech
STRUCTURAL ENGINEERS
License No. C-3870
318 W Millbrook Rd, Suite 201
Raleigh, North Carolina 27609
ASSOCIATES, P.A. Phone (919) 844-1661

SCOPE	FRESH PAINT
LOC	STRUCTURAL ADDENDUM
PLAN:	TBD
	MASTER
	FORGET ME NOT
	REV 1 9/2/2022
	REV 2 11/28/2022

ENG: NBC/CMC
DATE: 5/19/2022

PROJECT NO.
22-30-060

SHEET NO.
S3A

3 of 6

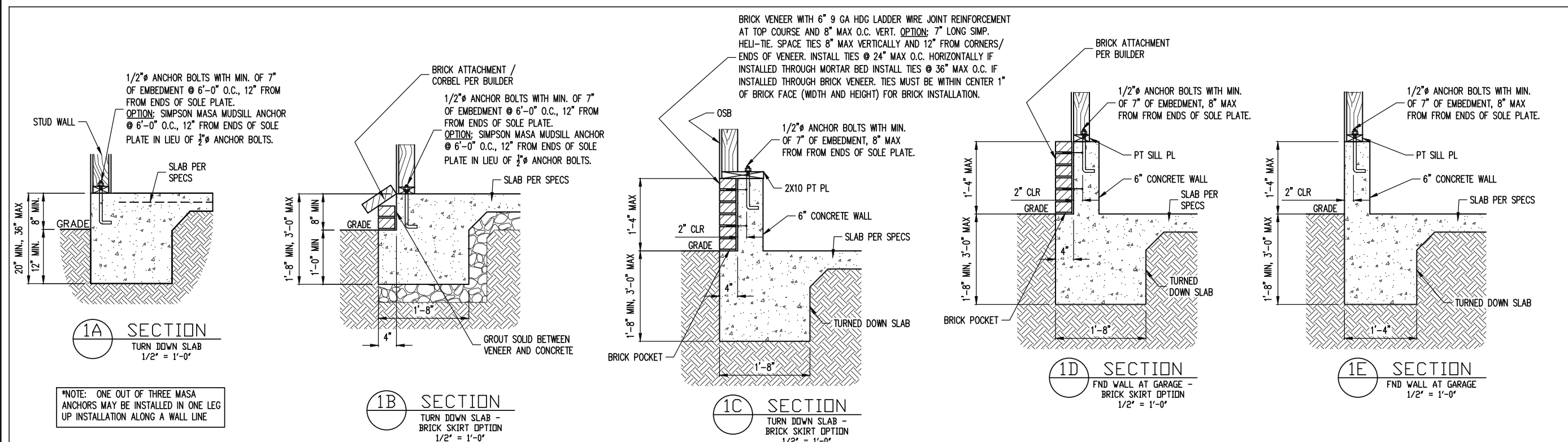

*NOTE: ONE OUT OF THREE MASA ANCHORS MAY BE INSTALLED IN ONE LEG UP INSTALLATION ALONG A WALL LINE

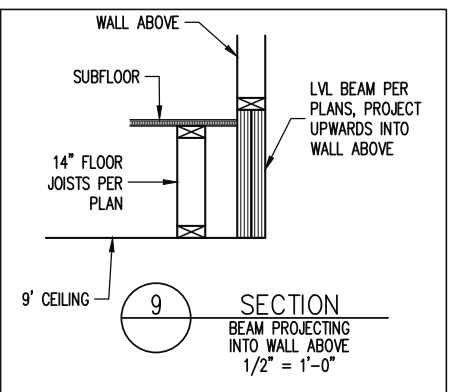
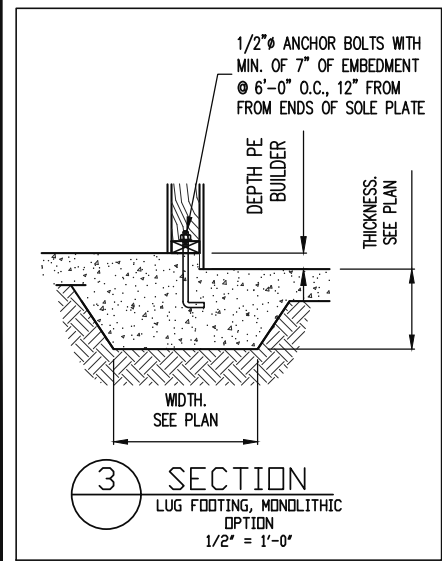
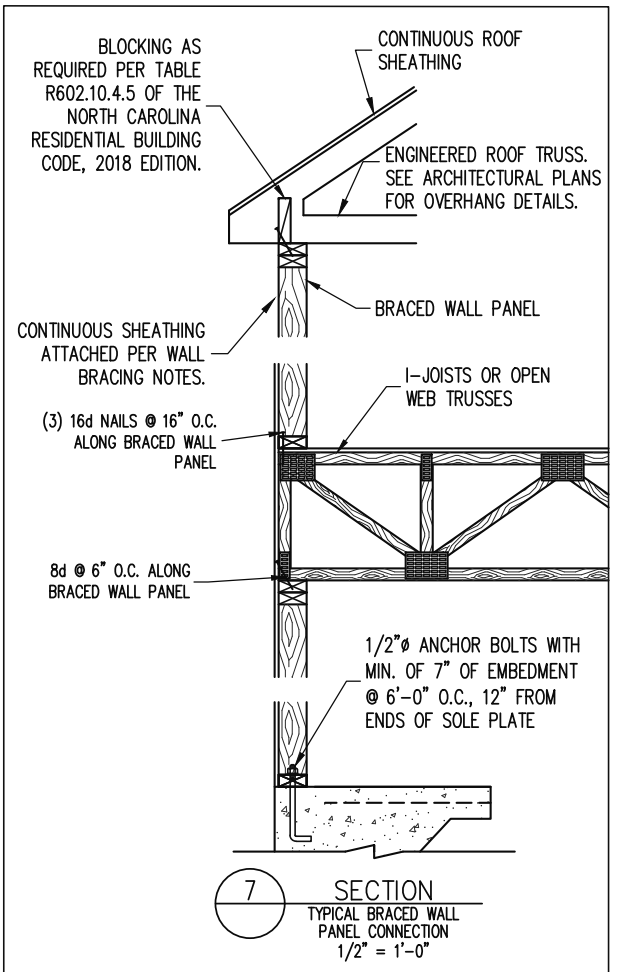
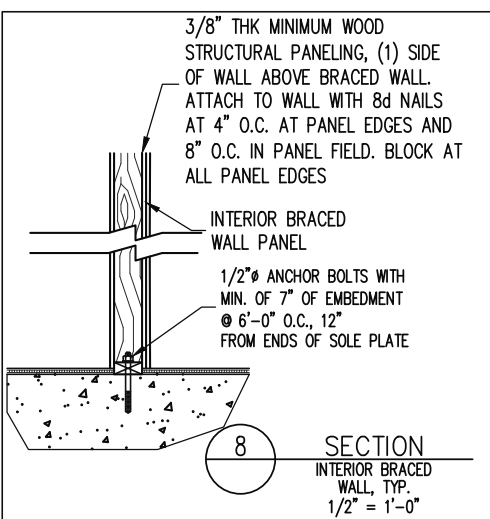
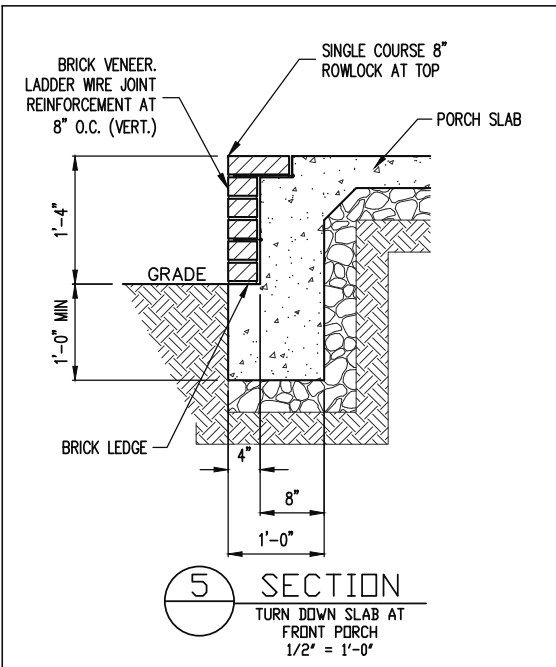
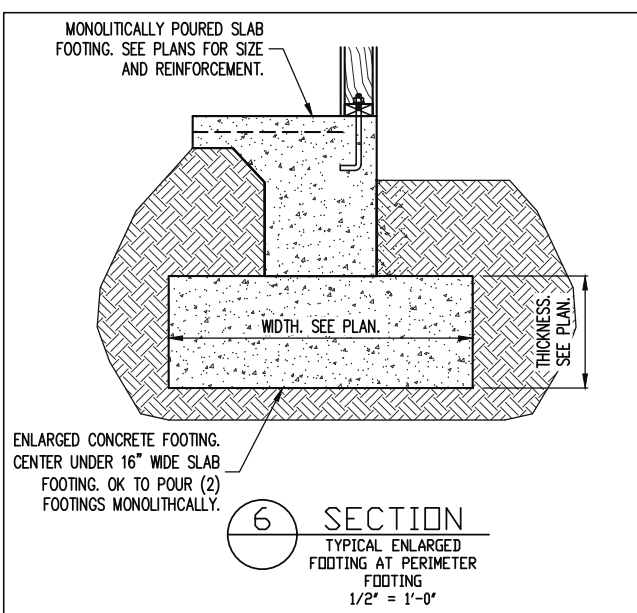
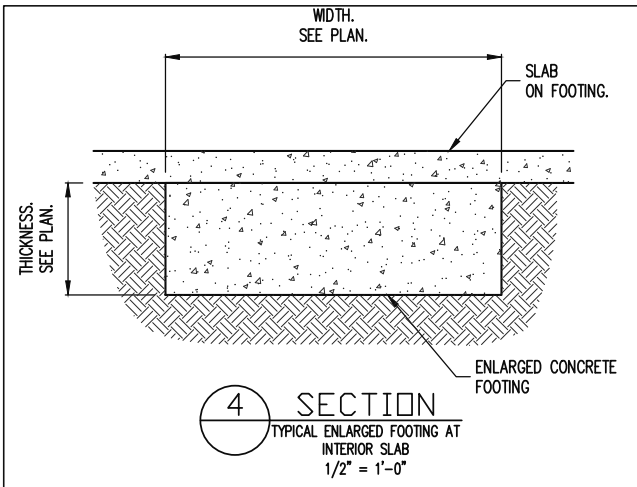
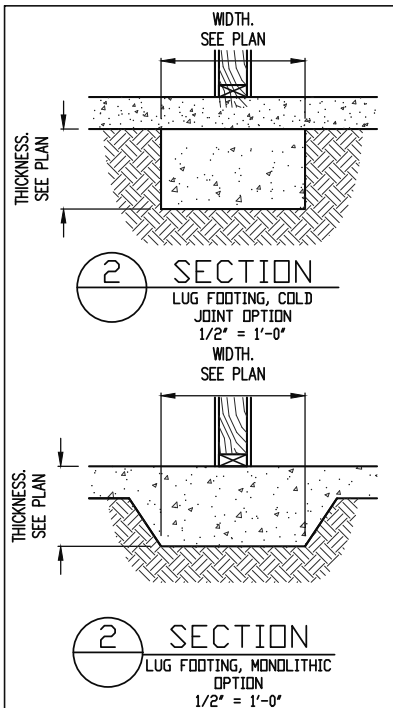
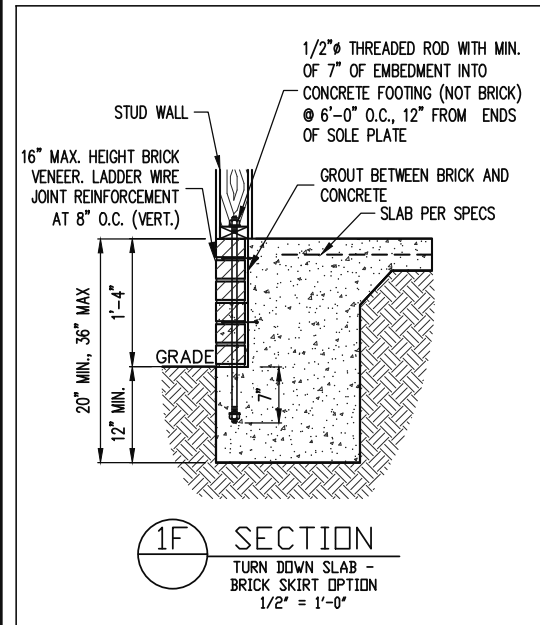
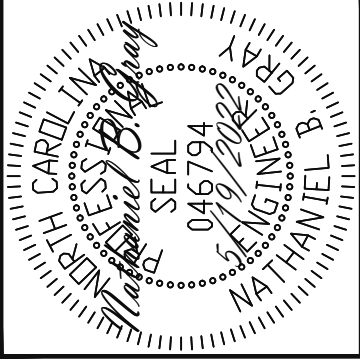

ENGINEERING SEAL VALID FOR 1 YEAR ONLY.
The structural design of this plan is the property of Engineering Tech Associates, P.A. These plans are for the client listed only. Engineering Tech Associates, P.A. assumes no liability for these plans if construction or permitting takes place more than 1 year after the seal date without written permission from Engineering Tech Associates, P.A.

Engineering Tech Associates, P.A.
STRUCTURAL ENGINEERS
License No. C-3870
318 W Millbrook Rd, Suite 201
Raleigh, North Carolina 27609
Phone (919) 844-1661

SCOPE	STRUCTURAL ADDENDUM	FRESH PAINT
LOC	TBD	
PLAN	MASTER	FORGET ME NOT
REV 1	9/2/2022	
REV 2	11/28/2022	

ENG: NBG/CMC
DATE: 5/19/2022

PROJECT NO.
22-30-060
SHEET NO.
SD1
5 of 6

CONSTRUCTION SPECIFICATIONS

PART 1: GENERAL

- 1.01 CONSTRUCTION SHALL MEET THE REQUIREMENTS OF THE NORTH CAROLINA RESIDENTIAL CODE, 2018 EDITION.
- 1.02 DIMENSIONS SHOWN SHALL GOVERN OVER SCALE ON THESE DRAWINGS.
- 1.05 METHODS, PROCEDURES AND SEQUENCES OF CONSTRUCTION ARE THE RESPONSIBILITY OF THE CONTRACTOR, WHO SHALL TAKE ALL NECESSARY PRECAUTIONS TO MAINTAIN AND INSURE THE INTEGRITY OF THE STRUCTURE AT ALL STAGES OF CONSTRUCTION.

PART 2: DESIGN LOADS

2.01 DESIGN LOADS SHALL CONFORM WITH THE TABLE BELOW:

USE	LIVE LOAD (PSF)	DEAD LOAD (PSF)
BALCONIES, DECKS, ATTICS WITH FIXED STAIR ACCESS, DWELLING UNITS INCLUDING ATTICS WITH FIXED STAIR ACCESS, STAIRS, FIRE ESCAPES	40	10
GARAGES (PASSENGER CARS ONLY)	50	--
ATTICS (NO STORAGE, LESS THAN 5' HEADROOM)	10	10
ATTICS (WITH STORAGE)	20	10
ROOF	20	10 (15 FOR VAULTS)

NOTES: - INDIVIDUAL STAIR TREADS ARE TO BE DESIGNED FOR THE UNIFORMLY DISTRIBUTED LIVE LOAD OF 40 PSF OR A 300 LB. CONCENTRATED LOAD ACTING OVER AN AREA OF 4 SQ. WHICHEVER PRODUCES THE GREATER STRESS.
- BUILDER TO VERIFY DEAD LOAD DOES NOT EXCEED 10 PSF WHEN HEAVY FLOOR OR ROOF FINISHES SUCH AS TILE OR SLATE ARE UTILIZED. NOTIFY ENGINEERING UNDER THESE CONDITIONS

- 2.02 INTERIOR WALLS: 5 PSF LATERAL
- 2.03 BASIC WIND DESIGN VELOCITY OF 120 MPH.
- 2.04 SOIL BEARING CAPACITY 2000 PSF (PRESUMPTIVE).

PART 5: CONCRETE AND SLABS ON GRADE

5.01 CAST IN PLACE CONCRETE SHALL BE OF NORMAL WEIGHT, 6% AIR ENTRAINMENT, AND SHALL HAVE A MINIMUM COMPRESSIVE STRENGTH OF 3000 PSI AT 28 DAYS TYP UNO. ALL CONCRETE, INCLUDING CONCRETE FOR FOOTINGS, IS TO BE CAST IN PLACE, TYP UNO.

5.03 SLABS ON GRADE, IF ANY, SHALL CONTAIN SYNTHETIC POLYPROPYLENE FIBRILLATED MICRO FIBERS, FIBER LENGTH 1 1/2", DOSAGE RATE 1 1/2 LBS/CU YD. SLAB TO BE PLACED ON A 6 MIL VAPOR BARRIER ON 2" MIN GRANULAR FILL ON SOIL WITH 90% MIN STANDARD PROCTOR DENSITY. VAPOR BARRIER MAY BE OMITTED FOR SLABS NOT IN ENCLOSED AREAS

PART 7: MASONRY

- 7.03 MORTAR SHALL BE TYPE S. MORTAR AND GROUT SHALL CONFORM TO ASTM C476, MIN COMPRESSIVE STRENGTH OF 2000 PSI.
- 7.05 LADDER WIRE REINFORCEMENT SHALL CONFORM TO ASTM A951. 6" MIN LAPS FOR CONTINUOUS WALL APPLICATIONS

PART 8: BOLTS AND LAG SCREWS

8.03 ANCHOR RODS AND BOLTS SHALL CONFORM TO ASTM F1554-15 GRADE 36 UNO. BENT ANCHOR BOLTS SHALL HAVE A 2" MIN HOOK UNO

PART 9: DRIVEN FASTENERS

9.01 NAILS, SPIKES AND STAPLES SHALL CONFORM TO ASTM F 1667- 05. NAILS ARE TO BE COMMON WIRE OR BOX

PART 10: DIMENSIONAL LUMBER

10.01 SOLID SAWN WOOD FRAMING DESIGN IS BASED ON NO. 2 SPRUCE PINE FIR OR SYP #2 FOR JOISTS, RAFTERS, GIRDERS, BEAMS, STUDS, ETC.

PART 11: ENGINEERED LUMBER

11.01 LVL OR PSL MINIMUM ALLOWABLE DESIGN STRESSES ARE AS FOLLOWS:
E= 1.9 X 10⁶ PSI, Fb = 2600 PSI, Fv = 285 PSI, Fc = 750 PSI
LSL MINIMUM ALLOWABLE DESIGN STRESSES ARE AS FOLLOWS:
E= 1.3 X 10⁶ PSI, Fb = 1700 PSI, Fv = 400 PSI, Fc = 680 PSI

11.02 LVL OR PSL MEMBERS MAY BE RIPPED FROM DEEPER MEMBERS TO MATCH THE MEMBER DEPTH SPECIFIED IN THE PLANS

PART 12: PRESSURE TREATED LUMBER

12.01 LUMBER IN CONTACT WITH THE GROUND, CONCRETE OR MASONRY SHALL BE PRESSURE TREATED IN ACCORDANCE WITH AWPA STANDARD C-15. ALL OTHER EXPOSED LUMBER SHALL BE TREATED IN ACCORDANCE WITH AWPA STANDARD C-2 OR BY ANY METHOD GIVING EQUAL PROTECTION. THE BUILDING CODE OFFICE MAY ALSO APPROVE A NATURAL DECAY RESISTANT WOOD PER SECTION 19-6(A)

PART 14: STUD SUPPORTS FOR BEAMS

14.01 STEEL, ENGINEERED LUMBER, AND FLITCH PLATE BEAMS BEARING ON A STUD WALL SHALL BEAR AS FOLLOWS:

1-WHEN THE BEAM IS PERPENDICULAR TO, OR SKEWED RELATIVE TO THE WALL, THE BEAM SHALL BEAR FULL WIDTH ON THE SUPPORTING WALL INDICATED AND SHALL BE SUPPORTED BY A MINIMUM OF THREE GANGED STUDS, OR A GANGED STUD COLUMN WITH A NUMBER OF STUDS SUCH THAT THE STUD COLUMN IS AT LEAST AS WIDE AS THE TRUE WIDTH OF THE BEAM BEING SUPPORTED, WHICHEVER IS GREATER, TYP UNO. FOR THE SKEWED CONDITION PARTICULAR CARE SHALL BE TAKEN TO ENSURE STUD COLUMN IS CENTERED ON THE BEAM

2-BEAMS BEARING ON THE END OF A STUD WALL PARALLEL TO THE BEAM SHALL BEAR A MINIMUM OF 4 1/2" ONTO THE WALL AND BE SUPPORTED BY A TRPL STUD GANGED COLUMN TYP UNO.

14.02 DIMENSIONAL LUMBER BEAMS BEARING ON A STUD WALL SHALL BEAR AS FOLLOWS:

1-WHEN THE BEAM IS PERPENDICULAR TO, OR SKEWED RELATIVE TO THE WALL, THE BEAM SHALL BEAR FULL WIDTH ON THE SUPPORTING WALL INDICATED (LESS 1 1/2" TO ALLOW FOR A CONTINUOUS RIM JOIST WHERE APPLICABLE) AND SHALL BE SUPPORTED BY A GANGED STUD COLUMN THE SAME WIDTH AS THE BEAM TYP UNO. (E.G. A TRIPLE 2X10 IS TO BE SUPPORTED BY (3) STUDS). FOR THE SKEWED CONDITION PARTICULAR CARE SHALL BE TAKEN TO ENSURE STUD COLUMN IS CENTERED ON THE BEAM

2-BEAMS BEARING ON THE END OF A STUD WALL PARALLEL TO THE BEAM SHALL BEAR A MINIMUM OF 3" ONTO THE WALL AND BE SUPPORTED BY A DBL STUD GANGED COLUMN TYP UNO.

14.03 EXTRA JOISTS BEARING ON A STUD WALL PERPENDICULAR TO OR SKEWED RELATIVE TO THE BEAM SHALL BE SUPPORTED BY ONE ADDITIONAL STUD.

14.04 STUDS THAT ARE GANGED TO FORM A COLUMN SHALL HAVE ADJACENT STUDS WITHIN THE COLUMN NAILED TOGETHER WITH ONE ROW OF 10d NAILS AT 8" O.C. (TWO ROWS OF 10d NAILS @ 8" O.C., 3" APART, FOR 2X8 OR 2X10 STUDS) ALL COLUMNS SHALL BE CONTINUOUS DOWN TO THE FOUNDATION OR OTHER PROPERLY DESIGNED STRUCTURAL ELEMENT SUCH AS A BEAM. COLUMNS TRANSFERRING LOADS THROUGH FLOOR LEVELS SHALL BE SOLIDLY BLOCKED FOR THE FULL WIDTH OF THE STUD COLUMN WITHIN THE CAVITY FORMED BY THE FLOOR JOISTS.

PART 15: NAILING OF MULTI PLY WOOD BEAMS

15.01 SOLID SAWN LUMBER JOISTS THAT ARE GANGED TO FORM A BEAM SHALL HAVE ADJACENT MEMBERS IN THE BEAM NAILED TOGETHER WITH THREE ROWS OF 10d NAILS @ 16" O.C. FOR 2X10 OR LARGER, TWO ROWS OF 10d NAILS @ 16" O.C. FOR 2X8, ONE ROW OF 10d NAILS @ 16" O.C. FOR 2X6 OR SMALLER. STAGGER ROWS 5" MIN.

15.02 LVL MEMBERS THAT ARE GANGED TO FORM A BEAM SHALL HAVE ADJACENT MEMBERS IN THE BEAM FASTENED TOGETHER PER MANUFACTURERS RECOMMENDATIONS, TYP UNO

PART 16: WALL FRAMING AND BRACING

16.01 STUD WALLS SHALL CONSIST OF 2X4 STUDS SPACED AT 16" O.C. UNO. STUDS SHALL BE CONTINUOUS FROM SOLE PLATE AT FLOOR TO DOUBLE TOP PLATE AT THE CEILING OR ROOF. NO INTERMEDIATE BANDS OR PLATES SHALL CAUSE DISCONTINUITIES IN A STUD WALL EXCEPT AS REQUIRED FOR DOOR OR WINDOW OPENINGS. THE KING STUDS FOR SUCH OPENINGS SHALL BE CONTINUOUS, TYP UNO.

MAX ALLOWABLE WALL HEIGHTS FOR EXTERIOR STUD WALLS, WITH SOLE PLATE AND DBL TOP PLATE AND 7/16" OSB EXTERIOR BRACING AND ROW OF 2X4 / 2X6 PURLINS AT 8' HEIGHT (AND AT 16' HEIGHT FOR TALL WALLS), TYP UNO:

16.02 FOR WALL BRACING THE FOLLOWING SHALL APPLY:

-BLOCKING AT UNSUPPORTED PANEL EDGES IS REQUIRED TYP UNO.
-WALL BRACING IS BY ENGINEERED DESIGN AND NOT PRESCRIPTIVE PER SECTION 602.10 OF THE 2018 NCRBC. CONTINUOUS SHEATHING HAS BEEN PROVIDED, ALONG WITH ALTERNATIVE METHODS TO INSURE THE MINIMUM INTENT OF SECTION 602.10 OF THE 2018 NCRBC HAS BEEN MET AND EXCEEDED.

-BRACED WALL PANELS SHALL BE FASTENED IN ACCORDANCE WITH TABLE 602.3(1) TO PROVIDE CONTINUOUS PANEL UPLIFT RESISTANCE AND COMPLIANCE WITH NCRBC R602.3.5 AND R802.11 UNLESS NOTED OTHERWISE ON STRUCTURAL PLANS.

-MAY SUBSTITUTE WSP FOR GB

-SINGLE JOIST, CONTINUOUS RIM JOIST, OR BLOCKING OF EQUAL DEPTH IS REQUIRED ABOVE AND BELOW ALL BRACED WALLS. NAIL BLOCKING ABOVE WALL TO TOP PLATE WITH 16d TOE NAILS @ 6" O.C. NAIL SOLE PLATE OF BRACED WALL TO BLOCKING BELOW WITH (3) 16d NAILS @ 16" O.C. BLOCKING AT HORIZONTAL JOINTS IN BRACED WALL LINES ONLY REQUIRED AT SHADED WALLS, UNO.

PART 17: KING STUDS

17.01 KING STUDS FOR OPENINGS IN EXTERIOR WALLS SHALL BE AS FOLLOWS:

MAX OPENING WIDTH	NUMBER OF KING STUDS				
	5'-0"	9'-0"	13'-0"	17'-0"	21'-0"
2X4	1	2	3	4	5
STUD SIZE	2X6	1	1	2	2
	2X8	1	1	1	2

PART 18: SUBSTITUTIONS

18.01 MATERIAL OR MEMBER SIZE SUBSTITUTIONS OR PLAN DEVIATIONS REQUIRE THE WRITTEN AUTHORIZATION OF THE DESIGNERS. UNAUTHORIZED DEVIATIONS ARE THE SOLE RESPONSIBILITY OF THE CONTRACTOR.

PART 19: OWNERSHIP OF STRUCTURAL DESIGN

19.01 THE STRUCTURAL DESIGN OF THIS PLAN IS THE PROPERTY OF ENGINEERING TECH ASSOCIATES (ETA). THESE PLANS ARE FOR THE ONE TIME USE AT THE LOCATION INDICATED AND FOR THE CLIENT LISTED. ETA ASSUMES NO LIABILITY FOR THESE PLANS IF THEY ARE REPRODUCED, IN WHOLE OR IN PART, FOR CONSTRUCTION AT ANY OTHER LOCATION WITHOUT WRITTEN PERMISSION FROM ETA

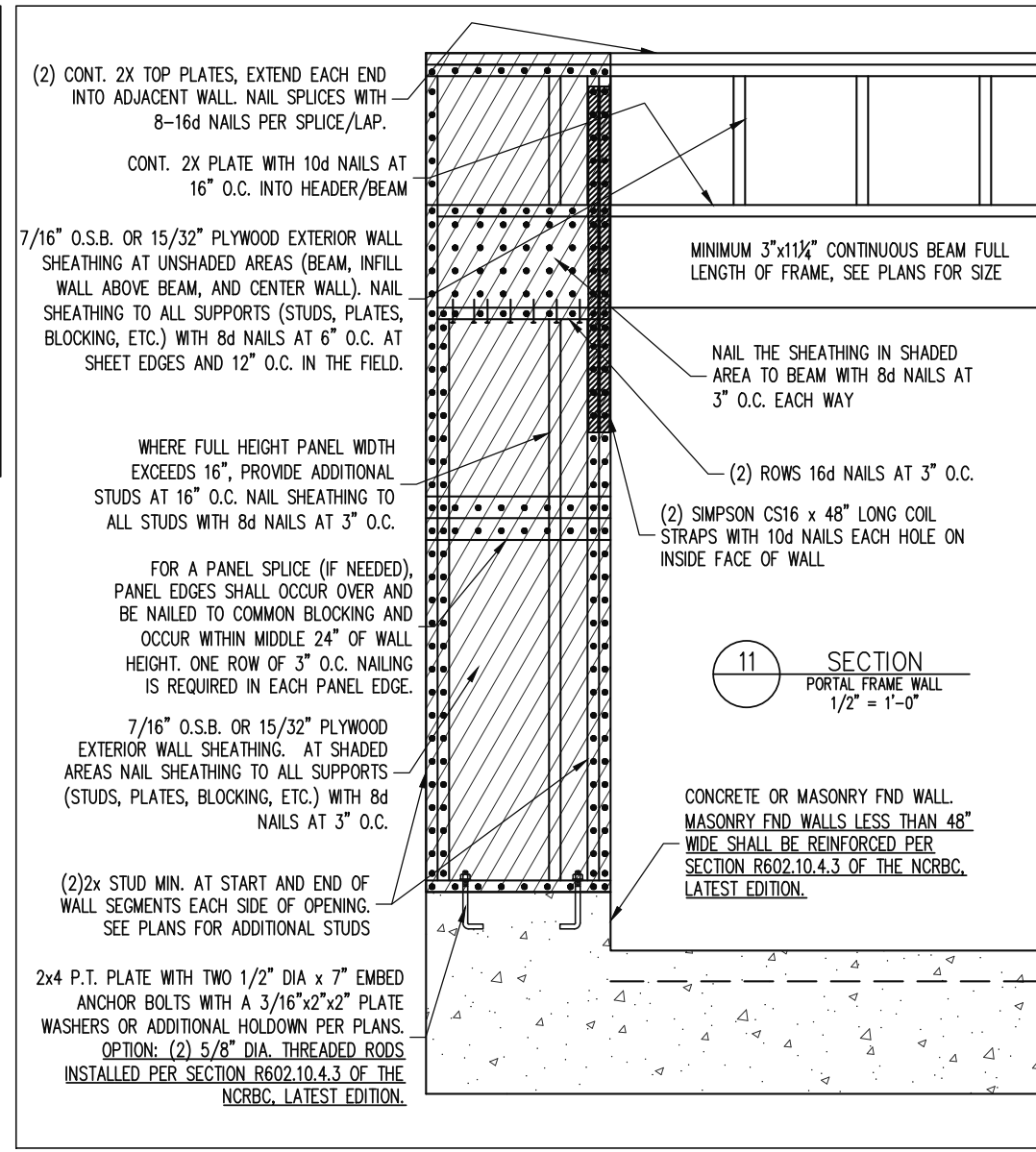
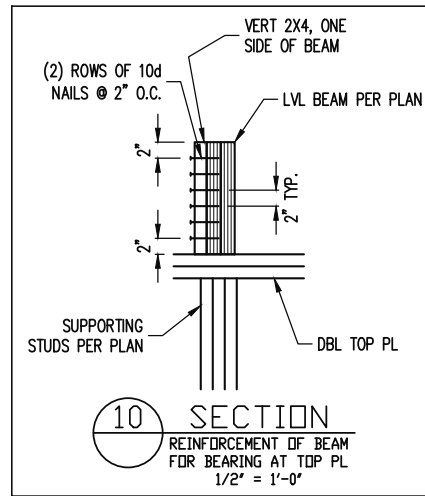

NOTES

THE BUILDER IS RESPONSIBLE FOR REVIEWING PLANS PRIOR TO CONSTRUCTION. THE BUILDER SHALL IMMEDIATELY CONTACT THE ENGINEER OF RECORD (EOR) BEFORE PROCEEDING IF THE FOLLOWING CONDITIONS ARE NOTED BEFORE OR DURING CONSTRUCTION:
1) THE WORKING PLANS DO NOT BEAR THE SEAL OF THE EOR
2) THE PLANS CONTAIN DISCREPANT OR INCOMPLETE INFORMATION

ANY ERRORS DUE TO A FAILURE TO FOLLOW THE ABOVE PROCEDURES SHALL NOT BE THE RESPONSIBILITY OF THE EOR. FURTHERMORE, IT IS THE RESPONSIBILITY OF THE BUILDER TO ENSURE THAT ANY REVISIONS ISSUED BY THE EOR ARE PROMPTLY DISTRIBUTED TO THE SUBCONTRACTORS

THE EOR DOES NOT PERFORM FENESTRATION OR VENTING CALCULATIONS OR ANY OTHER CALCULATIONS THAT ARE NOT DIRECTLY RELATED TO STRUCTURAL ENGINEERING.

ROOF AND FLOOR TRUSSES TO BE DESIGNED BY AN ENGINEER REGISTERED BY THE STATE. FINAL TRUSS DRAWING SHOULD BE SUBMITTED TO THE EOR FOR REVIEW

ABBREVIATIONS

ABV	ABOVE	FND	FOUNDATION	TJ	TRIPLE JOIST
B	BOTH	FTG	FOOTING	TYP	TYPICAL
B.E.	BOTH ENDS	HDG	HOT DIPPED	TRPL	TRIPLE
BTWN	BETWEEN		GALVANIZED	TSP	TRIPLE STUD POCKET
CIP	CAST IN PLACE	HGR	HANGER	UNO	UNLESS NOTED OTHERWISE
CONC	CONCRETE	LVL	LAMINATED VENEER LUMBER	XJ	EXTRA JOIST
CS	CONTINUOUS SHEATHING	NTS	NOT TO SCALE		
DIA	DIAMETER	O.C.	ON CENTER		
DBL	DOUBLE	PSL	PARALLEL STRAND LUMBER		
DJ	DOUBLE JOIST	PT	PRESSURE TREATED		
DSP	DBL STUD POCKET	QJ	QUAD JOIST		
EQ	EQUAL	SP	STUD POCKET		
EA	EACH	SQ	SQUARE		
FLG	FLANGE				
FL PL	FLITCH PLATE				
FLR	FLOOR				

ALLOWABLE I-JOIST SUBSTITUTION

NOTE: MAINTAIN JOIST DEPTH, DIRECTION, AND SPACING SPECIFIED ON PLANS.

MANUFACTURER	DEPTH	SERIES	SIMPSON FACE MOUNT HGR	SIMPSON TOP FLANGE HGR
BLUELINX	14"	BLI 40	IUS2.56/14	ITS2.56/14
BOISE CASCADE	14"	BCI 5000s	IUS2.06/14	ITS2.06/14
BOISE CASCADE	14"	BCI 6000S	IUS2.37/14	ITS2.37/14
LP CORP	14"	LPI 20+	IUS2.56/14	ITS2.56/14
NORDIC	14"	NI 40X	IUS2.56/14	ITS2.56/14
ROSEBURG	14"	RFP1 40s	IUS2.56/14	ITS2.56/14
WEYERHAEUSER	14"	TJ1 210	IUS2.06/14	ITS2.06/14
WEYERHAEUSER	14"	EEL-20	IUS2.37/14	ITS2.73/14

JOISTS NOT LISTED IN THE ABOVE TABLE MAY BE USED PROVIDED THEY MEET OR EXCEED THE PROPERTIES OF THOSE LISTED. SUBSTITUTE USP BRAND HANGERS WITH EQUIVALENT VALUES AS DESIRED.

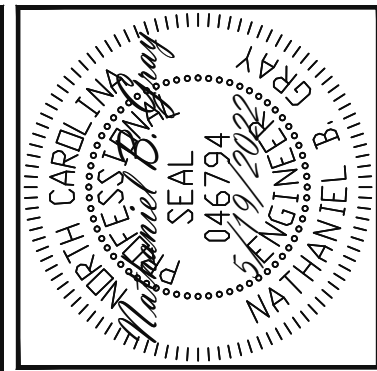

Engineering Tech Associates, P.A.
STRUCTURAL ENGINEERS
License No. C-3870
318 W Millbrook Rd, Suite 201
Raleigh, North Carolina 27609
Phone (919) 844-1661

FRESH PAINT

SCOPE: STRUCTURAL ADDENDUM
LOC: TBD
PLAN: MASTER

REV 1 9/2/2022
REV 2 11/28/2022

FORGET ME NOT

ENG: NBG/CMC
DATE: 5/19/2022

PROJECT NO.: 22-30-060

SHEET NO.: SD2

6 of 6

ENGINEERING SEAL VALID FOR 1 YEAR ONLY. The structural design of this plan is the property of Engineering Tech Associates, P.A. These plans are for the client listed only. Engineering Tech Associates, P.A. assumes no liability for these plans if construction or permitting takes place more than 1 year after the seal date without written permission from Engineering Tech Associates, P.A.