

Re: 230493DS1

Site Information:

Project Customer:	-	Project Name:	230493DS1
Lot/Block:	254	Subdivision:	Serenity
Address:	255 Sneed Ln.	Model:	Buttercup
City:	Fuquay Varina, NC, 27526	State:	North Carolina

Name Address and License # of the Building Designer, if there is one, for the Building:

Name:	-	License:	-	State:	North Carolina
Address:	-	City:	-		

The Truss Manufacturer (TM) is Carolina Structural Systems

The TM has Communicated Truss Design Criteria (TDC) to DrJ Engineering, LLC (DrJ). Refer to the individual Truss Design Drawings (TDDs) for specifics. Building Code, Software & engineering information follows:

Design Code:	IRC2018
Software Program:	Mitek
Truss Design Engineer:	Ryan Dexter

The TM has obtained, through the TM's Customer, the TDC & Truss design requirements from the Construction Documents &/or one of the Construction Professionals. The TM has Communicated the TDC & any related Truss design requirements to DrJ. This Communication includes transfer of TDC & any related Truss design requirements using proprietary Truss industry Software. DrJ designs each individual Truss, as illustrated on each TDD, relying upon the accuracy & completeness of Communicated information.

The seal on the Cover/Truss Index Sheet & on the individual TDD represents acceptance of responsibility for the review of the TDC & the design of each individual Truss. Each Truss then becomes one element of a Building Structural System (BSS). For any other BSS information needed, please contact the TM.

The TM is responsible for supplying the truss-to-truss connector type. Contact the TM for questions regarding truss-to-truss connector type, application and/or installation.

All dimensions are reproduced from the referenced Building Designer's plans.

WARNING: Always review the handling, storage, installation, lateral restraint & diagonal bracing information provided by TM through their delivery of the Truss Submittal Package (TSP). Do not cut or alter any part of a Truss or Structural Element. Never stack building material without proper lateral restraint & diagonal bracing. Never overload/exceed the design load shown on any TDD or Structural Element design drawing (SEDD). Property damage &/or personal injury happen when there is complacency regarding safety items. DrJ presumes the TM submits their TSP to be reviewed, approved & used by one or more of the following: building Owner, Building Official, Building Designer, Registered Design Professional in Responsible Charge, Contractor &/or Framer.

My license renewal date for North Carolina is 12/31/2023 DrJ Consulting, PLLC P-1038

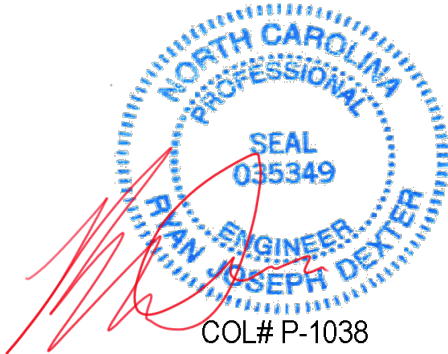

COL# P-1038

Ryan Dexter 9/20/2023

Scope of Work and Definitions

DrJ is a professional engineering company, which is defined as an Approved Source. In addition, DrJ is an ANAB accredited ISO/IEC 17065 Approved Agency. Approval or acceptance of the work of an Approved Source is determined by the Approved Source employing properly licensed professional engineers. Similarly, approval or acceptance of an Approved Agency is by the Approved Agency being a properly accredited third party certification body.

The DrJ scope of work is to undertake the structural analysis needed to create the TDDs listed here. TDDs prepared by DrJ are Instruments of Service for use solely for the named Project. This includes documents in electronic form. DrJ shall be deemed the author & owner of its Instruments of Service & shall retain all copyrights, common law statutory & other reserved rights. The Instruments of Service shall not be used by anyone for future additions or alterations of this Project or for other Projects without prior written instruction by DrJ. Any unauthorized use of the Instruments of Service shall be at the sole risk of the TM &/or other user & DrJ shall not have liability for this use.

For its engineering evaluation and structural design work, DrJ relies upon the accuracy of published raw material (i.e., lumber, OSB, etc.) & manufactured product design values. In addition, DrJ relies upon a product manufacturer's published product, material, design &/or method of construction pursuant to an ISO/IEC 17065 technical evaluation report or a sealed & signed report, which include but is not limited to design values, applications, conditions of use, quality, installation, bracing, & repair requirements. DrJ makes no representation or warranty with respect to raw material or manufactured product performance.

Capitalized terms & responsibilities are defined pursuant to the applicable building code, applicable reference standards, the latest edition of TPI 1, the National Design Specification® for Wood Construction (NDS), applicable professional engineering law, Appendix A Commentary/Definitions, Appendix B: Project/Deliverables, definitions created within Design Drawings &/or definitions within Reference Sheets. Terms not defined shall have ordinarily accepted meanings as the context implies. All pages of this document must be presented together to be considered complete.

All pages of this document must be presented together to be considered complete.

Construction Materials: Lumber, Metal Plate Connectors (MPCs) & Other Fasteners

Commodity lumber Design Values, specified in the NDS, are defined as strength & stiffness property values of structural lumber products published for design use. These values are determined for specific grades & species/species groups. Sawn lumber used for load-supporting purposes, including end-jointed, edge-glued, machine stress-rated or machine-evaluated lumber, shall be identified by the Grade mark of a lumber grading or inspection agency that has been approved by an Accreditation Body that complies with the latest edition of the DOC PS 20 American Softwood Lumber Standard or equivalent. Approved end-jointed lumber is permitted to be used interchangeably with solid-sawn members of the same species & grade. End-jointed lumber used in an assembly required to have a fire-resistance rating shall have the designation "Heat Resistant Adhesive" or "HRA" included in its grade mark. DrJ relies upon each lumber manufacturer to provide building code conforming Design Values, conditions of use, quality, & repair requirements as well as compliance with DOC PS 20 & the NDS Supplement, as pertinent.

MPCs are presumed to be manufactured, tested & identified in accordance with TPI 1. The design & performance of each Truss rely upon the MPC manufacturer's published ISO/IEC 17065 technical evaluation report &/or a sealed & signed Research Report that delineates design values, performance, application, installation, conditions of use, quality, & repair requirements.

The NDS provides design values for generic fastener types (e.g., bolts, nails, wood screws, spikes, timber rivets, drift pins, steel side plates, etc.)

Structural capacities for commodity & proprietary fastener types & steel side plates are presumed to be established, monitored, manufactured & identified in accordance with ASTM A36, ASTM A153/A153-16A, ASTM A307, ASTM A576, ASTM A576 GR1015 Modified, ASTM F606/F606M, ASTM A641/A641M, ASTM A653 Structural Grade (GR) 33, ASTM A653M SR 33, ASTM A675 GR60, ASTM A1011 SS GR33, ASTM D1761, ASTM D5764, ASTM D7147, ASTM F606/F606M, ASTM F680, ASTM F1575, ASTM F1667, including Supplement 1, ASTM F3359, &/or ASTM SAE J429 GR 2, as pertinent.

For proprietary manufactured structural fastener products & steel side plates, DrJ relies upon the manufacturer's published ISO/IEC 17065 technical evaluation report &/or a sealed & signed Research Report that delineates design values, performance, application, installation, conditions of use, quality, & repair requirements.

DrJ relies upon quality assurance being performed by an Approved Agency &/or Approved Source (e.g., ISO/IEC 17020, professional engineer, etc.).

DrJ makes no representation or warranty & is not liable for: 1) the accuracy of the TM's Communication, 2) lumber Design Values, 3) MPC design values, 4) the accuracy of Software, 5) building code compliance of any Structural Element as used in the BSS, 6) the existence of Grade Marks on lumber 7) the contents of any TSP &/or 8) the design values, quality or installation of any commodity or proprietary product. In addition, Appendix A Commentary/Definitions & Appendix B Project/Deliverables, & the DrJ Reference Sheet contain pertinent information.

Job 230493DS1	Truss A02	Truss Type Common	Qty 1	Ply 1	Garman Homes - Buttercup A & B Job Reference (optional)	Paragon ID: 45635 P4889347
------------------	--------------	----------------------	----------	----------	--	-------------------------------

Run: 8.62 S Oct 13 2022 Print: 8.620 S Oct 13 2022 MiTek Industries, Inc. Tue Sep 19 09:14:29

REPAIR:

1) LOWER TOP CHORD 5-9 BY 2" AT PEAK AS SHOWN.

- NOTE - THIS REPAIR IS VALID FOR THE DESIGN CONDITIONS PROVIDED IN THIS TRUSS REPAIR DRAWING. IT'S ADEQUACY FOR THE ACTUAL CONDITIONS MUST BE VERIFIED BY OTHERS.
- REFER TO ORIGINAL TRUSS DESIGN DRAWING FOR ADDITIONAL NOTES.
- IF TRUSS IS IN PLACE, SHORE UP TRUSS TO RELIEVE ANY LOAD IT MAY BE SUPPORTING BEFORE BEGINNING REPAIR.
- UNLESS OTHERWISE SPECIFIED, REMOVE ALL ELECTRICAL, MECHANICAL, PLUMBING, ETC. RUNS INTERFERING WITH THE REPAIR MATERIALS AND RE-ROUTE. DO NOT CUT, DRILL, NOTCH, OR MODIFY REPAIR MATERIALS.

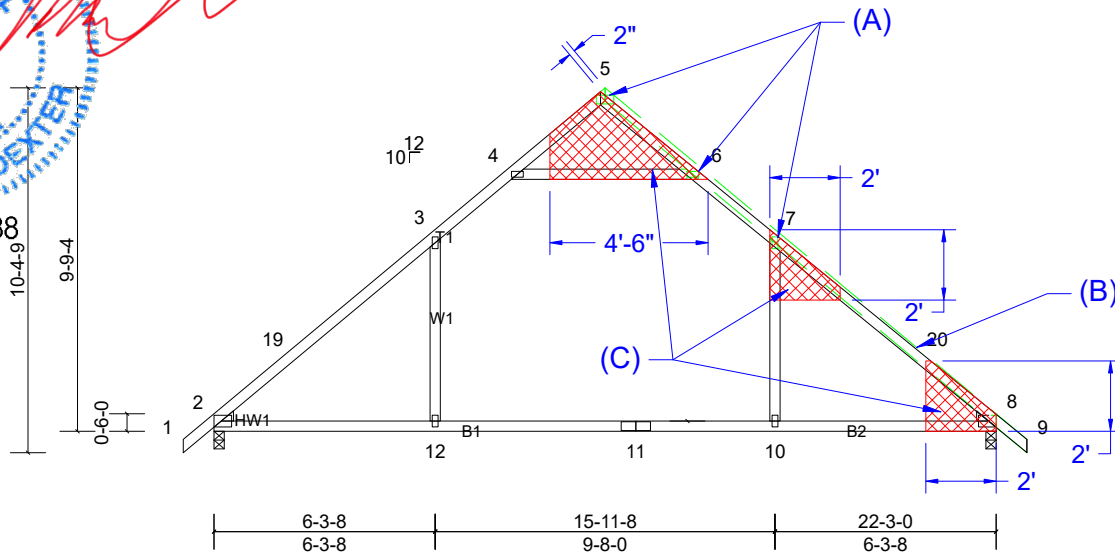
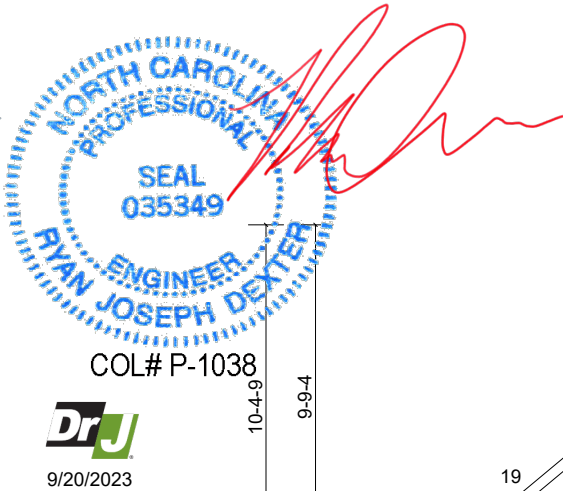

(A) LUMBER AND CONNECTOR PLATES TO BE CUT CLEANLY AND ACCURATELY AND THE REMAINING PLATE(S) MUST BE FULLY EMBEDDED AND UNDISTURBED. DO NOT OVERCUT.

(B) PUSH TOP CHORD DOWN, ROTATING ABOUT JOINT 8. SO THAT IS APPX. 2" LOWER AT PEAK. TOP CHORD TO SIT TIGHT AGAINST ALL INTERSECTING MEMBERS.

(C) APPLY 7/16" 24/16 SPAN RATED OSB GUSSETS TO EACH SIDE OF TRUSS AS SHOWN. ATTACH EACH GUSSET WITH (2) ROWS OF 10d (3" X 0.131") NAILS: SPACED @ 4" OC INTO ALL MEMBERS. DRIVE NAILS THROUGH BOTH GUSSETS AND CLINCH. STAGGER SPACING FROM FRONT SIDE TO BACK SIDE FOR A NET 2" OC SPACING IN THE TRUSS MEMBER. CIRCLE ON CORNER OF GUSSET REPRESENTS INTERSECTION LOCATION WITH MEMBER.

Loading	(psf)	Spacing		CSI		DEFL	in	(loc)	l/defl	L/d	PLATES	GRIP
TCLL (roof)	20.0	Plate Grip DOL	2-0-0	TC	0.59	Vert(LL)	-0.51	10-12	>521	240	MT20	244/190
TCDL	10.0	Lumber DOL	1.00	BC	0.96	Vert(CT)	-0.82	10-12	>324	180	MT18HS	244/190
BCLL	0.0*	Rep Stress Incr	1.15	WB	0.59	Horz(CT)	0.03	2	n/a	n/a		
BCDL	10.0	Code	YES	Matrix-AS								
		IRC2015/TPI2014									Weight: 105 lb	FT = 20%

LUMBER

TOP CHORD	2x4 SP DSS
BOT CHORD	2x4 SP No.1
WEBS	2x4 SP No.3
WEDGE	Left: 2x4 SP No.3 Right: 2x4 SP No.3

BRACING

TOP CHORD	Structural wood sheathing directly applied.
BOT CHORD	Rigid ceiling directly applied.

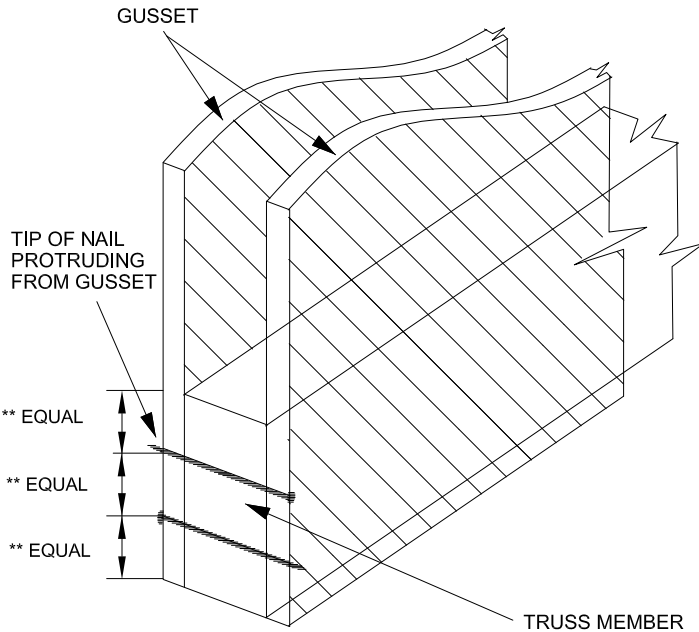

FIGURE 1

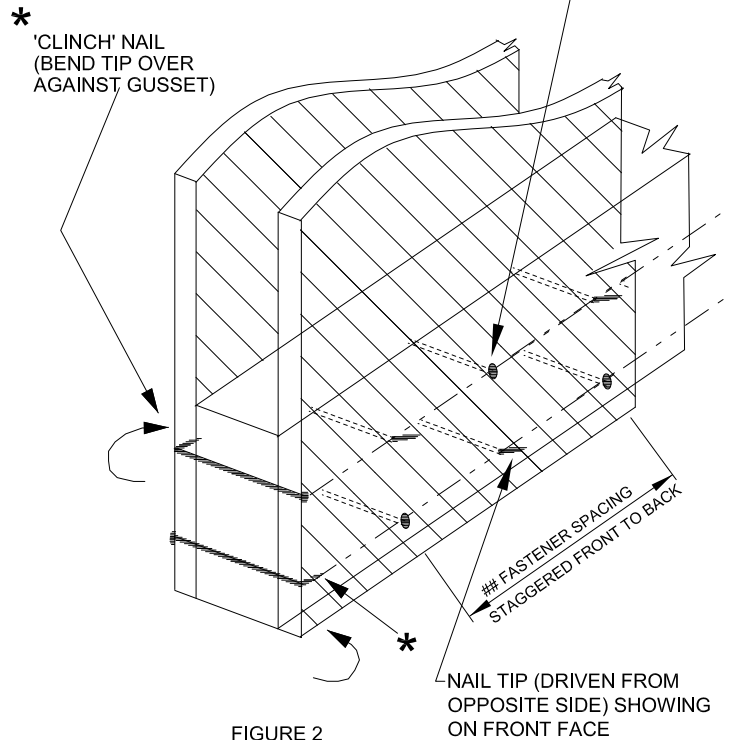

FIGURE 2

** ROWS ARE TO BE EQUALLY SPACED $\pm \frac{1}{2}$ " FROM TOP OF TRUSS MEMBER TO BOTTOM OF TRUSS MEMBER.

FASTENER SPACING IS TO BE AS CALLED OUT ON THE REPAIR DRAWING $\pm \frac{1}{2}$ ".

STAGGER SPACING FROM FRONT SIDE TO BACK SIDE = $\frac{\text{FASTENER SPACING}}{2} \pm \frac{1}{2}$ ".

REPAIR DRAWINGS OFTEN INDICATE THAT THE SPECIFIED NAILS MUST BE 'CLINCHED'. THIS PROCESS REQUIRES THE GUSSETS TO BE APPLIED TO THE FRONT AND BACK FACES OF THE TRUSS PRIOR TO NAILING. THE NAILS ARE DRIVEN THROUGH THE FIRST GUSSET, THE TRUSS, THEN THE BACK GUSSET. THE NAILS ARE NOW PROTRUDING OUT OF THE BACK GUSSET (SEE FIGURE 1). THE NEXT STEP IS TO HAMMER THE PROTRUDING TIP OF THE NAIL OVER AGAINST THE FACE OF THE BACK GUSSET (SEE FIGURE 2).

IT IS IMPORTANT THAT THE GUSSETS ARE TIGHT AGAINST EACH FACE WHEN NAILING. THIS MAY BE ACHIEVED BY CLAMPING OR SCREWING THE GUSSETS TO THE TRUSS. IF SCREWS ARE USED, APPLY ONLY ENOUGH TO SECURE THE GUSSETS DURING NAILING.

PLEASE NOTE THAT APPLYING ONE GUSSET AND NAILING IT COMPLETELY, THEN APPLYING THE SECOND GUSSET ONLY PROVIDES APPROXIMATELY 75 PERCENT OF THE DESIGNED STRENGTH. THIS IS NOT AN ACCEPTABLE METHOD OF ATTACHMENT !

IT IS ACCEPTABLE TO APPLY ALL NAILS FROM ONE FACE. HOWEVER, DRJ RECOMMENDS NAILING FROM OPPOSITE FACES IN A STAGGERED PATTERN AS INDICATED IN THE DETAILS SHOWN.

WHEN ATTACHING GUSSETS, THE USE OF A BACK-UP WEIGHT IS RECOMMENDED TO AVOID LOOSENING OF THE CONNECTOR PLATES AT THE JOINTS OR SPLICES. THIS ALSO PREVENTS THE TRUSS FROM DEFLECTING LATERALLY DURING APPLICATION OF THE REPAIR, PROVIDING EASIER NAILING.



9/20/2023



COL# P-1038



DrJ Reference Sheet

WARNING Always review the handling, storage, installation, lateral restraint & diagonal bracing information provided by the Truss Manufacturer (TM) through their delivery of the Truss Submittal Package (TSP). Do not cut or alter any part of a Truss or Structural Element. Never stack building material without proper lateral restraint & diagonal bracing. Never overload/exceed the design load shown on any TDD or Structural Element Design Drawing (SEDD). Property damage &/or personal injury happen when there is complacency regarding safety items. DrJ presumes the TM submits their TSP to be reviewed, approved & used by one or more of the following; building Owner, Building Official, Building Designer, Registered Design Professional in Responsible Charge, Contractor &/or Framer.

Scope of Work and Definitions

The Truss Manufacturer (TM) is Carolina Structural Systems

The TM has obtained, through TM's Customer, the Truss Design Criteria (TDC) & Truss design requirements from the Construction Documents &/or the Construction Professionals. The TM has Communicated the TDC & any related Truss design requirements to DrJ. This Communication includes transfer of TDC & any related Truss design requirements using proprietary Truss industry Software. DrJ designs each individual Truss, as illustrated on each TDD, relying upon the accuracy & completeness of Communicated information.

DrJ presumes that the Communicated TDC & Truss design requirements conform to ANSI/TPI 1-2014, National Design Standard for Metal Plate Connected Wood Trusses (TPI 1). This includes but is not limited to: (a) allowable vertical, horizontal or other required deflection criteria; (b) any lateral thrust developed by scissors-type Trusses; (c) modeling requirements for scissors trusses; (d) any dead load, live load & in-service creep deflection criteria for floors or flat roofs; (e) any floor or roof camber requirements; (f) any Truss-to-Truss or Truss-to-adjacent structural member differential deflection criteria; (g) any special floor truss deflection criteria &/or vibration criteria including but not limited to strongback bridging requirements; (h) any dead load, live load, & in-service creep deflection criteria for floors supporting stone or ceramic tile finishes; (i) any conditions where moisture, temperature, corrosive chemicals & gases are expected to result in a wood moisture content exceeding 19% &/or sustained temperatures exceeding 150°F; (j) any conditions where wood preservatives or other sources of corrosion may affect the truss design; (k) standard & unique design loads; (l) standard & unique truss spacing; & (m) building code used for the design of the Building Structural System.

DrJ designs each individual Truss, as illustrated on each TDD, relying upon the accuracy & completeness of Communicated information.

The seal on the Cover/Truss Index Sheet & on the individual TDD represents acceptance of responsibility for the review of the TDC & the design of each individual Truss. Each Truss then becomes one element of a Building Structural System (BSS). For any other BSS information needed, please contact the TM, &/or any of the following Construction Professionals; the building Owner, Building Designer, building Registered Design Professional in Responsible Charge, &/or Contractor (e.g., general, MEP, Framer, etc.).

DrJ is a professional engineering company, which is defined as an Approved Source. In addition, DrJ is an ANAB accredited ISO/IEC 17065 Approved Agency. Building Official Acceptance of an Approved Source is determined by the Approved Source employing properly licensed professional engineers. Similarly, acceptance of an Approved Agency is by the Approved Agency being a properly accredited third party certification body.

The DrJ scope of work is to undertake the structural analysis needed to create the TDDs listed here. TDDs prepared by DrJ are Instruments of Service for use solely for the named Project. This includes documents in electronic form. DrJ shall be deemed the author & owner of its Instruments of Service & shall retain all copyrights, common law statutory & other reserved rights. The Instruments of Service shall not be used by anyone for future additions or alterations of this Project or for other Projects without prior written instruction by DrJ. Any unauthorized use of the Instruments of Service shall be at the sole risk of the TM &/or other user & DrJ shall not have liability for this use.

As permitted by the applicable material chapters & referenced standards of the listed building code, DrJ structural design may use strength design, load & resistance factor design, allowable stress design, empirical design, &/or conventional construction methods, as pertinent. The TDD defines the individual Truss that safely supports the factored loads or nominal loads, in load combinations defined in the listed building code, without exceeding the appropriate strength limit states or allowable stresses, as pertinent.

For its engineering evaluation & structural design work, DrJ relies upon the accuracy of published raw material (e.g., lumber, OSB, etc.) & manufactured product design values (e.g., I-joists, LVL, wood structural panels, metal connector plates, fasteners, etc.). In addition, DrJ relies upon a product manufacturer's published product, material, design &/or method of construction pursuant to an ISO/IEC 17065 technical evaluation report or a sealed & signed report, which include but is not limited to design values, applications, conditions of use, quality, installation, bracing, & repair requirements. DrJ makes no representation or warranty with respect to raw material or manufactured product performance.

When the TM has provided a Truss Placement Diagram (TPD) in its TSP, it is an illustration that identifies the assumed location of each individually identified Truss to aid Truss installation. Contact the TM for questions regarding the TPD &/or Truss installation.

The TM is responsible for supplying the truss-to-truss connector type. Contact the TM for questions regarding truss-to-truss connector type, application &/or installation.

All dimensions are reproduced from the referenced Building Designer's plans.

Capitalized terms and responsibilities are defined pursuant to the applicable building code, applicable reference standards, the latest edition of TPI 1, the National Design Specification® for Wood Construction (NDS), applicable professional engineering law, Appendix A Commentary/Definitions, Appendix B: Project/Deliverables, definitions created within Design Drawings &/or definitions within Reference Sheets. Terms not defined shall have ordinarily accepted meanings as the context implies.

Compliance with the referenced building code is confirmed when: 1) the "for construction" TDDs have been examined for conformance with the local building code & requirements of pertinent laws, 2) any non-conformance is provided in writing to DrJ stating the reasons for the non-conformance, 3) the non-conformance is cured, 4) the plan examination & approval of the TDDs is complete, & 5) required inspections are complete.

All pages of this document must be presented together to be considered complete.

Truss Design

Each TDD is created by various Software developers & produces engineering analysis. Software generates framing layout, design, manufacturing, &/or management data/output consistent with the TM's business procedures, inventory & Selectable Software Parameters. Software is used under a Software license agreement between the TM & Software developer. Reliance upon the Software company, by the TM and DrJ, includes but is not limited to; all Software warranties, its use of accepted engineering mechanics models, its use of appropriate design equations, its use of accurate mathematical analysis, its use of any needed calibration to testing, its accuracy in the context of TPI 1 &/or NDS requirements, that output derived from the Software is appropriate for the pertinent building code & for the end use intended when used in accordance with Software instructions & guidance from the Software developer, & any unique characteristics delineated by the Software output for each singular Truss & its TDD or TRD. Given Service reliance upon proprietary Software, DrJ cannot be responsible for any interruption of the use of Software outside of the control of DrJ. Each TDD indicates the minimum lumber species, size & grade required to be used. Lumber with higher Design Values can be substituted.

Each TDD indicates the plate type, minimum size, orientation, & location for each truss joint. Use of Metal Plate Connectors (MPCs) with wider widths &/or longer lengths of the same gauge are permitted.

Each TDD presumes that the top chords are sheathed or continuous lateral restraint members (i.e., purlins) are provided at the spacing indicated on TDD (e.g., 24 in. o.c. maximum). Graphical representation of lateral restraint members (i.e., web member restraint, purlins, etc.), if shown on the TDD, do not illustrate the size or orientation of the restraint along the top chord, bottom chord &/or web members.

Attachment of a purlin gable (e.g., hip frames, lay-in gables, etc.) to the supporting hip Trusses satisfies the compression bracing requirements for the top chord of hip Trusses. Refer to the TDD to locate hip Trusses that have been designed to have this type of top chord compression bracing.

Sheathing applied in the plane of the Truss is NOT considered in the design of the individual Truss unless specifically noted otherwise (i.e., a Gable End Truss has not been designed using composite stiffness analysis).

Each TDD presumes Trusses are installed vertically.

Each TDD presumes dry & non-treated lumber is used.

When fire-retardant, preservative-treated, or green lumber is used it is specifically noted on each TDD where it is used.

DrJ presumes that the Truss depicted on each TDD meets the minimum manufacturing quality requirements specified in Chapter 3 of TPI 1 so that design assumptions are met. DrJ also relies upon quality assurance being performed by an accredited agency (e.g. ISO/IEC 17020, professional engineer, etc.). DrJ makes no representation or warranty regarding the performance of each manufactured Truss.

Construction Materials: Lumber, Metal Plate Connectors & Other Fasteners

Commodity lumber Design Values, specified in the NDS, are defined as strength & stiffness property values of structural lumber products published for design use. These values are determined for specific grades & species/species groups. Sawn lumber used for load-supporting purposes, including end-jointed, edge-glued, machine stress-rated or machine-evaluated lumber, shall be identified by the Grade mark of a lumber grading or inspection agency that has been approved by an Accreditation Body that complies with the latest edition of the DOC PS 20 American Softwood Lumber Standard or equivalent. Approved end-jointed lumber is permitted to be used interchangeably with solid-sawn members of the same species & grade. End-jointed lumber used in an assembly required to have a fire-resistance rating shall have the designation "Heat Resistant Adhesive" or "HRA" included in its grade mark. DrJ relies upon each lumber manufacturer to provide building code conforming Design Values, conditions of use, quality, & repair requirements as well as compliance with DOC PS 20 & the NDS Supplement, as pertinent.

MPCs are presumed to be manufactured, tested & identified in accordance with TPI 1. The design & performance of each Truss rely upon the MPC manufacturer's published ISO/IEC 17065 technical evaluation report &/or a sealed & signed Research Report that delineates design values, performance, application, installation, conditions of use, quality, & repair requirements.

The NDS provides design values for generic fastener types (e.g., bolts, nails, wood screws, spikes, timber rivets, drift pins, steel side plates, etc.)

Structural capacities for commodity & proprietary fastener types & steel side plates are presumed to be established, monitored, manufactured & identified in accordance with ASTM A36, ASTM A153/A153-16A, ASTM A307, ASTM A576, ASTM A576 GR1015 Modified, ASTM F606/F606M, ASTM A641/A641M, ASTM A653 Structural Grade (GR) 33, ASTM A653M SR 33, ASTM A675 GR60, ASTM A1011 SS GR33, ASTM D1761, ASTM D5764, ASTM D7147, ASTM F606/F606M, ASTM F680, ASTM F1575, ASTM F1667, including Supplement 1, ASTM F3359, &/or ASTM SAE J429 GR 2, as pertinent.

For proprietary manufactured structural fastener products & steel side plates, DrJ relies upon the manufacturer's published ISO/IEC 17065 technical evaluation report &/or a sealed & signed Research Report that delineates design values, performance, application, installation, conditions of use, quality, & repair requirements.

DrJ relies upon quality assurance being performed by an Approved Agency &/or Approved Source (e.g., ISO/IEC 17020, professional engineer, etc.).

DrJ makes no representation or warranty & is not liable for: 1) the accuracy of the TM's Communication, 2) lumber Design Values, 3) MPC design values, 4) the accuracy of Software, 5) building code compliance of any Structural Element as used in the BSS, 6) the existence of Grade Marks on lumber 7) the contents of any TSP &/or 8) the design values, quality or installation of any commodity or proprietary product. In addition to this DrJ Reference Sheet, Appendix A Commentary/Definitions & Appendix B Project/Deliverables, contain pertinent information.



The DrJ Reference Sheet will be updated annually on 12/31 of each year & supersedes all prior versions & understandings with respect to the DrJ Reference Sheet.

The DrJ Reference Sheet may also be updated periodically during the year upon Communication of DrJ to Carolina Structural Systems

Copyright © 2011-2022 DrJ Engineering, LLC All Rights Reserved. DrJ Design Drawings are valid for nine (9) months from the Document Date.

Numbering System

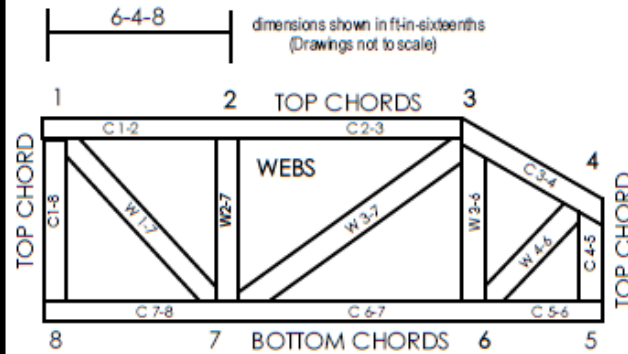

JOINTS ARE GENERALLY NUMBERED/LETTERED CLOCKWISE AROUND THE TRUSS STARTING AT THE JOINT FARTHEST TO THE LEFT.

CHORDS AND WEBS ARE IDENTIFIED BY END JOINT NUMBERS/LETTERS.

Symbols

PLATE LOCATION AND ORIENTATION

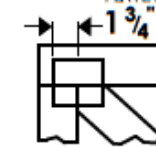

Center plate on joint unless x, y offsets are indicated. Dimensions are in ft-in-sixteenths (x-x'-x''). Apply MPCs to both sides of Truss and fully embed teeth.

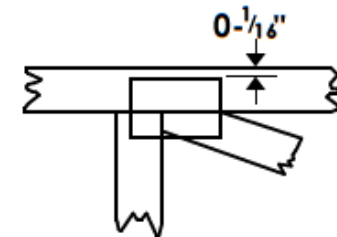

For 4 x 4 orientation, locate plates 0 - 1/16" from outside edge of Truss.



This symbol indicates the required direction of slots in the MCP.

*MCP location details available upon request from

MCP SIZE

4 x 4

The first dimension is the MCP width measured perpendicular to slots. Second dimension is the MCP length parallel to slots.

LATERAL RESTRAINT LOCATION



Indicated by symbol shown and/or by text in the bracing section of the output. Use T-, L-, or I-Reinforcement or proprietary bracing if indicated. NOTE - LATERAL RESTRAINTS MUST BE BRACED. REFER TO BCS1 OR AS SPECIFIED BY THE BD.

BEARING



Indicates location where bearings (supports) occur. Joins vary but reaction section indicates joint number where bearings occur.