

HICKORY ELEVATION E



PRINCE PLACE LOT 50

3-CAR
FRONT LOAD
OPTION

CRAWL VENTING	
1277 SQ FT OF FOUNDATION TO BE VENTED	
150 SQ FT / 1 SQ FT = 8.51 SQ FT VENTILATION	
VENTS 128 SQ IN = (0.8889 SQ FT)	
CRAWL VENT	
8.513 SQ FT	= 30.6 VENTS REQUIRED
0.2778 SQ FT	
ACTUAL CRAWL VENTS PROVIDED 31	
NOTE: WHERE AN APPROVED VAPOR BARRIER IS INSTALLED OVER GROUND SURFACE THE REQUIRED VENTILATION MAY BE REDUCED BY 50%	

GENERAL NOTES:

SITE CONSTRUCTION:

- SOIL BEARING CALCULATIONS BASED ON 2000 PSF MIN. REFER TO THE FOUNDATION/FOOTING SCHEDULE.
- BACK FILL SHALL BE FREE FROM VEGETATION AND CONSTRUCTION DEBRIS.
- BACK FILL SHALL BE PLACED IN LIFTS AND COMPACTED IN SUCH A MANNER AS TO NOT DAMAGE THE FOUNDATION WALLS OR ANY WATERPROOFING/ DAMP PROOFING MATERIALS.

FRAMING:

- ALL DIMENSIONS ARE FROM FACE OF STUD TO FACE OF STUD. ALL STUDS ARE 3 1/2" UNLESS NOTED. ALL DIMENSIONS PRESENTED HERE ARE FRAME DIMENSIONS ONLY.
- PROVIDE 1x BLOCKING UNDER ALL EXTERIOR SLIDING DOORS.
- JOIST HANGERS, WHERE REQUIRED, SHALL BE USED WITHOUT ANGLES.
- INSTALL FIRE STOPPING AND/ OR DRAFT STOPPING AS REQUIRED.
- PROVIDE CUTTING, NOTCHING, NAILING REQUIREMENTS PER 2009-IRC SECTIONS R502.8 R602, R802.7.

THERMAL & MOISTURE PROTECTION:

- INSTALL FIRE STOPPING AND/ OR DRAFT STOPPING AS REQUIRED.
- ATTIC VENTILATION SHALL BE PROVIDED AT 1/150th OF THE AREA OF THE SPACE VENTILATED. CROSS VENTILATION WITH HALF OF THE VENTILATED AREA SHALL BE PROVIDED BY RIDGE OR GABLE VENTS AND THE OTHER HALF BY EAVE OR CORNICE VENTS. VENTS SHALL BE PLACED SO AS TO NOT ALLOW INFILTRATION OF RAIN OR SNOW.
- PROVIDE APPROVED TILE BACKER BOARD FOR ALL SHOWER AND BATH SPACE.
- PROVIDE ICE-SHIELD PER CODE.
- ROOF VENTING TO BE PROVIDED AS SHOWN. SOFFIT, RIDGE, AND OTHER ROOF VENTS TO BE INSTALLED AS NOTED ON THE DRAWINGS & AS PER MANUFACTURERS RECOMMENDATIONS.

DOORS & WINDOW:

- WINDOW CALL OUT PER PLAN. VERIFY WINDOW MANUFACTURER WITH PROJECT MANAGER.
- REVIEW ALL WINDOW HEADER HEIGHTS PER PLATE HT. AND VERIFY W/ ELEVATIONS AND CORNICE DETAILS.
- TEMPERED GLASS SHALL BE USED IN ALL HAZARDOUS AREAS.
- FRONT DOOR WIDTH AS REQUIRED BY CODE.
- GARAGE DOOR AS REQUIRED BY CODE.
- EMERGENCY - SLEEPING ROOMS SHALL HAVE AT LEAST ONE EGRESS OPENING OF NOT LESS THAN 5.7 SF AND A CLEAR OPENING OF NOT LESS THAN 20" WIDE X 24" HIGH AND SHALL NOT BE MORE THAN 44" ABOVE THE FLOOR.

INSULATION:

EXTERIOR WALLS ZONE 3:
R-13 BATTS MINIMUM. VERIFY

CEILING WITH ATTIC ABOVE COMPRESSED INSULATION:
R-38 BATTS MINIMUM. VERIFY

CEILING WITH ATTIC ABOVE UNCOMPRESSED INSULATION (HEELS IN TRUSSES):
R-30 BATTS MINIMUM. VERIFY

FLOOR OVER GARAGE:
R-19 BATTS MINIMUM. VERIFY

ATTIC KNEEWALL:
R-19 BATTS MINIMUM. VERIFY

- THE ATTACHED PLANS & SPECIFICATIONS ARE THE SOLE PROPERTY OF DAVIDSON HOMES. ANY UNAUTHORIZED USE OF THESE PLANS WITHOUT PRIOR WRITTEN CONSENT OF DAVIDSON HOMES IS STRICTLY PROHIBITED.
- MAIN STREET DESIGNS OF GEORGIA, LLC DESIGNS HOUSING AS SET FORTH BY THE FORMAT AND PROVISIONS OF THE INTERNATIONAL RESIDENTIAL CODE (IRC), AND THE NATIONAL ELECTRIC CODE (NEC).
- THESE PLANS ARE SUBJECT TO MODIFICATIONS TO MEET CODE REQUIREMENTS AND/OR TO FACILITATE MECHANICAL/ ELECTRICAL/ PLUMBING INSTALLATION AND/ OR TO IMPLEMENT DESIGN IMPROVEMENTS.
- CONTRACTOR SHALL BE RESPONSIBLE FOR VERIFYING ALL DIMENSIONS AFFECTING CONTRACTOR'S PRODUCTS, INSTALLATIONS, OR FABRICATIONS IN THE FIELD PRIOR TO EXPEDITING THE CONSTRUCTION OF SUCH WORK. FIELD VERIFY ALL DIMENSIONS - DO NOT SCALE DRAWINGS. CONTRACTOR IS RESPONSIBLE FOR SURVEYING THE PROJECT AND BECOMING FAMILIAR WITH THE EXISTING CONDITIONS AND SCOPE OF WORK INCLUDING BUT NOT LIMITED TO SITE AND SOIL BEARING CONDITIONS.
- ERRORS AND OMISSIONS WHICH MAY OCCUR IN THE CONTRACT DOCUMENTS SHALL BE BROUGHT TO THE ATTENTION OF MAIN STREET DESIGNS OF GEORGIA, LLC IN WRITING, AND WRITTEN INSTRUCTION SHALL BE OBTAINED PRIOR TO PROCEEDING WITH CONSTRUCTION. THE CONTRACTOR SHALL BE HELD RESPONSIBLE FOR ANY ERRORS, DISCREPANCIES, OR OMISSIONS FOR WHICH THE CONTRACTOR FAILED TO NOTIFY MAIN STREET DESIGNS OF GEORGIA, LLC PRIOR TO CONSTRUCTION AND/ OR FABRICATION OF THE WORK.
- FLAME SPREAD AND SMOKE DENSITY NOTES:

WALLS AND CEILING:

WALL AND CEILING FINISHES SHALL HAVE A FLAME - SPREAD CLASSIFICATION OF NOT GREATER THAN 200. WALL AND CEILING FINISHES SHALL HAVE A SMOKE-DEVELOPED INDEX OF NOT GREATER THAN 450.

INSULATION:

IF BATT OR BLANKET INSULATION, INCLUDING FACINGS SUCH AS VAPOR RETARDERS OR OTHER VAPOR PERMEABLE MEMBRANES ARE LEFT EXPOSED (IN AREAS LIKE UNFINISHED BASEMENTS), THE MATERIAL SHALL HAVE A FLAME SPREAD RATING OF 25 OR LESS AND A SMOKE DEVELOPMENT RATING OF 450 OR LESS. FLAME-SPREAD AND SMOKE-DEVELOPMENT LIMITATIONS DO NOT APPLY TO FACINGS THAT IS INSTALLED IN SUBSTANTIAL CONTACT WITH THE UNEXPOSED SURFACE OF THE CEILING, FLOOR, OR WALL FINISH.

EXCEPT WHERE OTHERWISE NOTED IN SECTION R314.2, ALL FOAM PLASTIC OR FOAM PLASTIC CORES IN MANUFACTURED ASSEMBLIES USED IN BUILDING CONSTRUCTION SHALL HAVE A FLAME-SPREAD RATING OF NOT MORE THAN 75 AND SHALL HAVE A SMOKE-DEVELOPMENT RATING OF NOT MORE THAN 450 WHEN TESTED IN THE MAXIMUM THICKNESS INTENDED FOR USE IN ACCORDANCE WITH ASTM E 84.

R314.1.2 THERMAL BARRIER. FOAM PLASTIC, EXCEPT WHERE OTHERWISE NOTED, SHALL BE SEPARATED FROM THE INTERIOR OF A BUILDING BY MINIMUM 1/2-INCH (12.7 MM) GYPSUM BOARD OR AN APPROVED FINISH MATERIAL EQUIVALENT TO A THERMAL BARRIER TO LIMIT THE AVERAGE TEMPERATURE RISE OF THE UNEXPOSED SURFACE TO NO MORE THAN 250°F (121°C) AFTER 15MINUTES OF FIRE EXPOSURE TO THE ASTM E 119 STANDARD TIME TEMPERATURE CURVE. THE GYPSUM BOARD SHALL BE INSTALLED USING A MECHANICAL FASTENING SYSTEM IN ACCORDANCE WITH SECTIOR702.3.5. RELIANCE ON ADHESIVES TO ENSURE THAT THE GYPSUM BOARD WILL REMAIN IN PLACE WHEN EXPOSED TO FIRE SHALL BE PROHIBITED.

BUILDING CODE ANALYSIS

APPLICABLE CODES	2018 NCRC/ 2018 IBC
USER GROUP:	SINGLE FAMILY
CONSTRUCTION CLASS:	UNPROTECTED
HEIGHT LIMITATION:	N/A
EMERGENCY ESCAPE:	EGRESS OR RESCUE WINDOWS FROM SLEEPING ROOM SHALL HAVE A MINIMUM OF 5.7 SQ. FT.
GARAGE / HOUSE CEILING/ HOUSE ASSEMBLY:	1/2" GYPSUM BD. WALL & 5/8"TYPE "X" GYPSUM BD. CEILING W/ 20 MINUTE GARAGE/HOUSE DOOR
DESIGN LOAD:	LIVE LOAD: SLEEPING = 30 PSF NON-SLEEPING = 40 PSF DECKS = 40 PSF DEAD LOAD = 10 PSF BASIC WIND SPEED = 115 MPH EXPOSURE B (CHARLOTTE) STAIR LOAD = 40 PSF ROOF LIVE LOAD = 20 PSF LATERAL SOIL PRESSURE = 30 PCF (ASSUMED)

NOTE: VERIFY ALL APPLICABLE BUILDING CODES WITH STATE AND LOCAL JURISDICTION PRIOR TO CONSTRUCTION

BASE HOUSE SQUARE FOOTAGE CALCULATIONS						TOTAL UNDER ROOF
ELEVATION	1st FLOOR	2nd FLOOR	TOTAL FIN.	FRONT PORCH	GARAGE	ROOF
ELEV. E	1,277 s.f.	1,458 s.f.	2,735 s.f.	183 s.f.	437 s.f.	3,355 s.f.
OPTIONS:	1st FLOOR					
3rd CAR GARAGE					+264 s.f.	
3rd FLOOR					+369 s.f.	
COVERED PORCH					+115 s.f.	

INCLUDED OPTIONS:
1st FLOOR
 COVERED PORCH
 GOURMET KITCHEN
 FIREPLACE
 BOX OAK STAIRS
 OPEN RAIL
 GUEST SUITE ILO STUDY
2nd FLOOR
 OPEN RAIL
 OWNERS SPA SHOWER
 2ND SINK @ BATH 2
 LAUNDRY SINK
3rd FLOOR
 MEDIA ROOM

REVISION NUMBER	PROTOTYPE REVISIONS
2-26-2020	ADDED BASEMENT FOUNDATION
3-13-2020	UPDATED SHOWER OPTIONS
7/1/2020	ELECTRICAL GARAGE LIGHT ELEV B
10/12/2020	ADDED GAR SVR DR TO 3RD CAR
10/23/2020	REVISIONS TO WH & GARAGE DOORS
3/29/2021	

MAIN STREET
DESIGNS

Main Street Designs of Georgia, LLC
 www.MainStreetDesignsLLC.com
 3650 Royal Blvd, South, Suite 135
 Alpharetta, GA 30022
 O. (404) 996-5722

DAVIDSON
HOMES
Your Community Builder

1/8" = 1'-0"

RELEASE DATE	03-29-2021
PROJECT NUMBER	---
OPTION NO.	---

MODEL	HICKORY
DRAWING TITLE	COVER SHEET
OPTION DESCRIPTION	

SHEET NO.
CS-1.0

**1st FLOOR PLAN
OPT. COVERED PORCH**

SCALE: 1/8"=1'-0" (11"x17" SHEET SIZE)
SCALE: 1/4"=1'-0" (22"x34" SHEET SIZE)

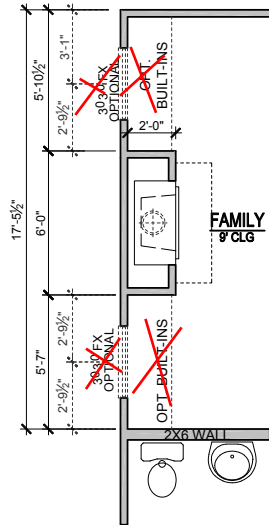

**1st FLOOR PLAN
OPT. FIREPLACE- 'B'**

SCALE: 1/8"=1'-0" (11"x17" SHEET SIZE)
SCALE: 1/4"=1'-0" (22"x34" SHEET SIZE)

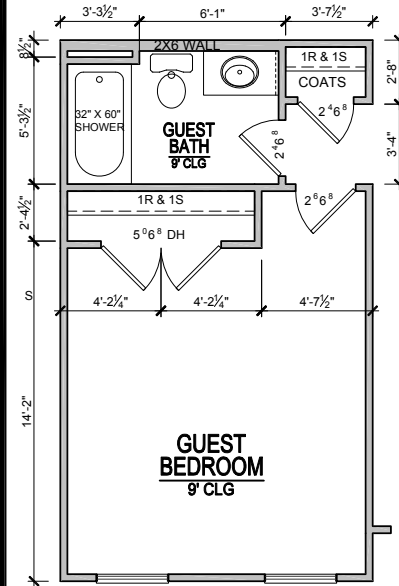

**GUEST BEDROOM
ILO SUDY**

SCALE: 1/8"=1'-0" (11"x17" SHEET SIZE)
SCALE: 1/4"=1'-0" (22"x34" SHEET SIZE)

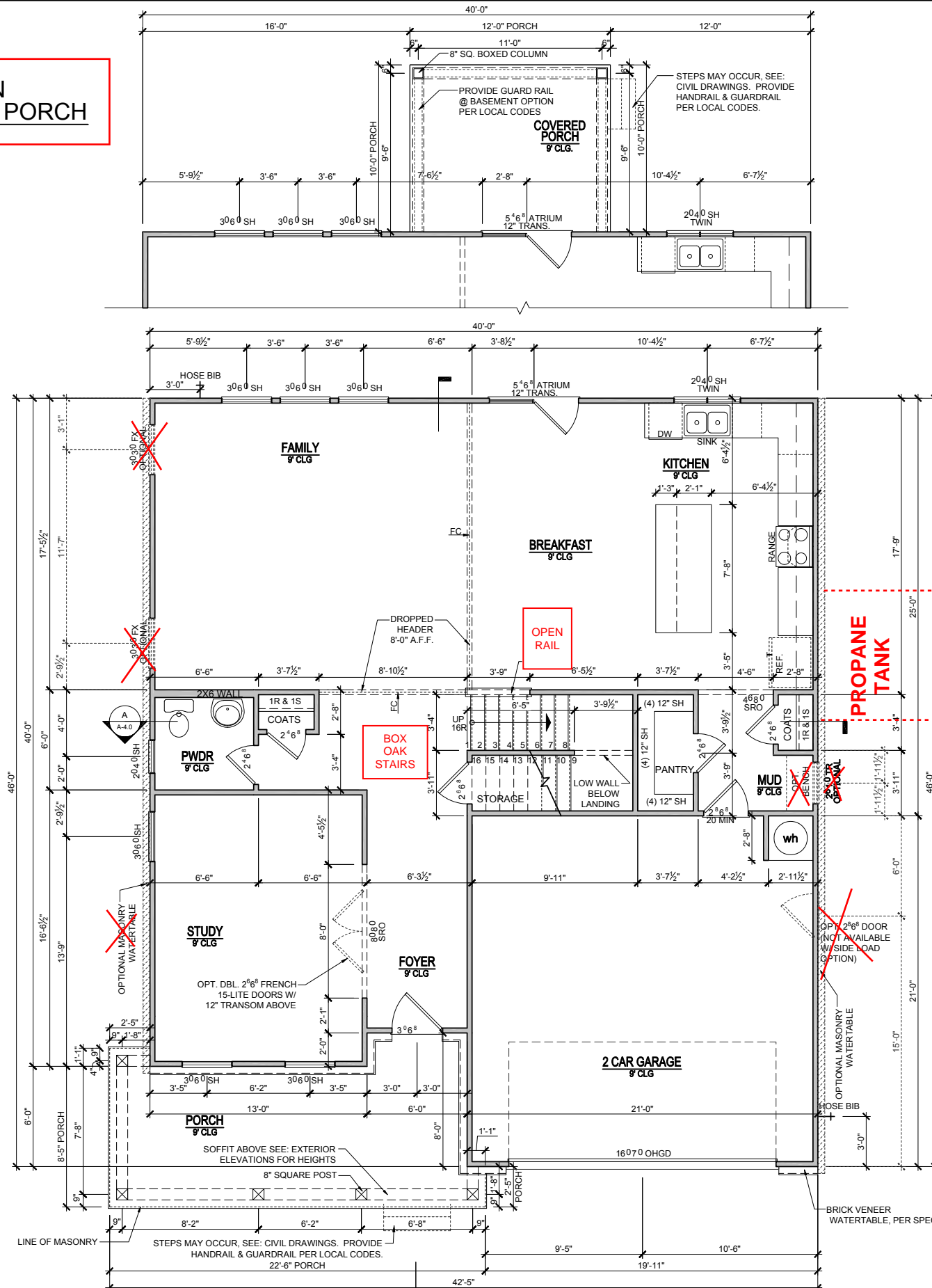

**ELEVATION - E
1st FLOOR PLAN**

SCALE: 1/8"=1'-0" (11"x17" SHEET SIZE)
SCALE: 1/4"=1'-0" (22"x34" SHEET SIZE)

GOURMET KITCHEN

SCALE: 1/8"=1'-0" (11"x17" SHEET SIZE)
SCALE: 1/4"=1'-0" (22"x34" SHEET SIZE)

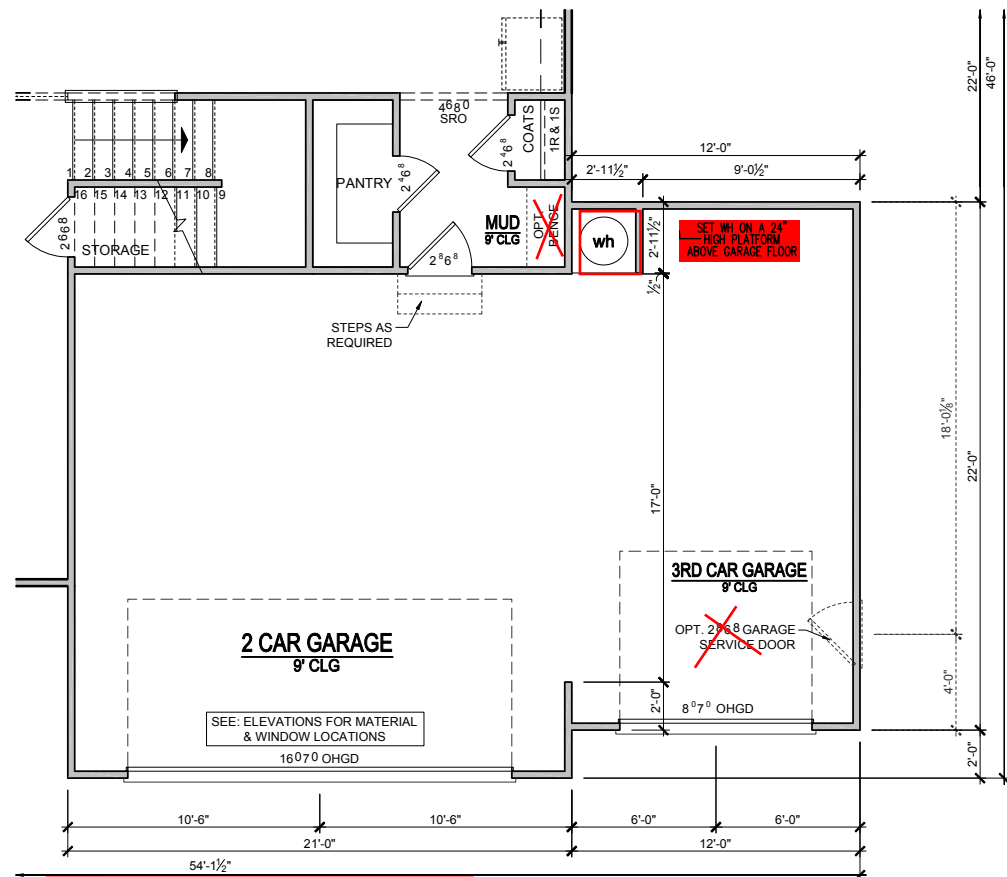
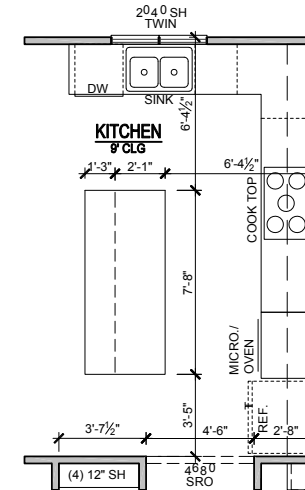

**1st FLOOR PLAN
OPT. 3rd CAR GARAGE**

SCALE: 1/8"=1'-0" (11"x17" SHEET SIZE)
SCALE: 1/4"=1'-0" (22"x34" SHEET SIZE)

**PRINCE
PLACE
LOT 50**

REVISION NUMBER	PROTOTYPE REVISIONS
2-26-2020	ADDED BASEMENT FOUNDATION
3-13-2020	UPDATED SHOWER OPTIONS
7/1/2020	ELECTRICAL GARAGE LIGHT ELEV B
10/12/2020	ADDED GAR SVR DR TO 3RD CAR
3/29/2021	REVISIONS TO WH & GARAGE DOORS

MAIN STREET DESIGN
Main Street Designs of Georgia, LLC
www.MainStreetDesigns.com
3650 Royal Blvd. South, Suite 135
Alpharetta, GA 30022
O. (404) 996-5722

**DAVIDSON
HOMES**
Your Community Builder

RELEASE DATE	03-29-2021
PROJECT NUMBER	
OPTION NO.	

MODEL	HICKORY
DRAWING TITLE	FIRST FLOOR PLAN
OPTION DESCRIPTION	ELEVATION - E

SHEET NO.
A-1.0E

PRINCE PLACE LOT 50

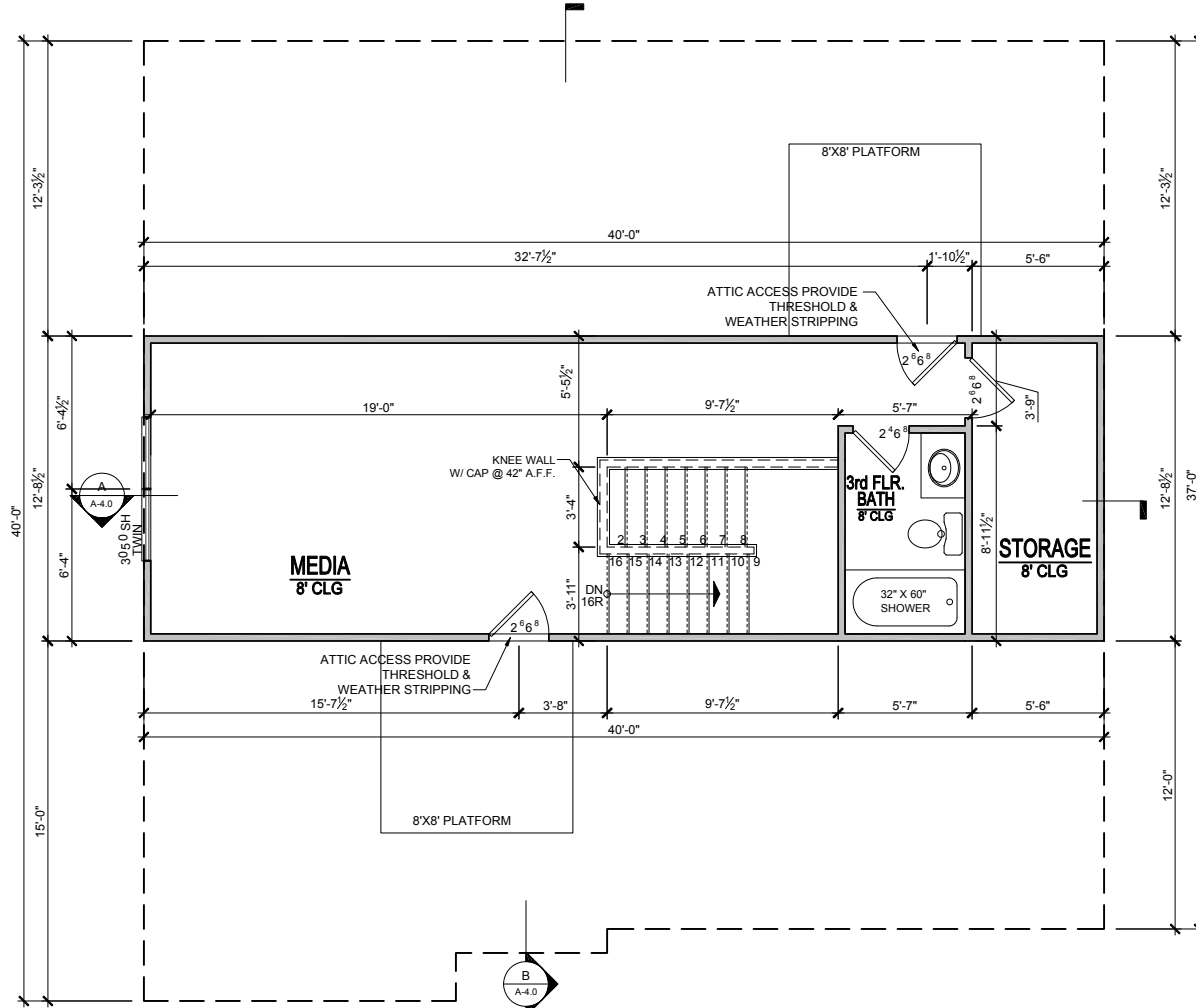

OPT. 3rd FLOOR PLAN
 SCALE: 1/8"=1'-0" (11"x17" SHEET SIZE)
 SCALE: 1/4"=1'-0" (22"x34" SHEET SIZE)

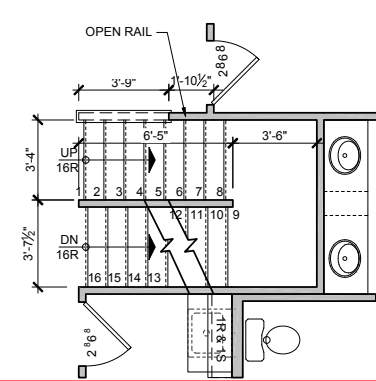

2nd FLOOR PLAN STAIRS TO OPT. 3RD. FLOOR
 SCALE: 1/8"=1'-0" (11"x17" SHEET SIZE)
 SCALE: 1/4"=1'-0" (22"x34" SHEET SIZE)

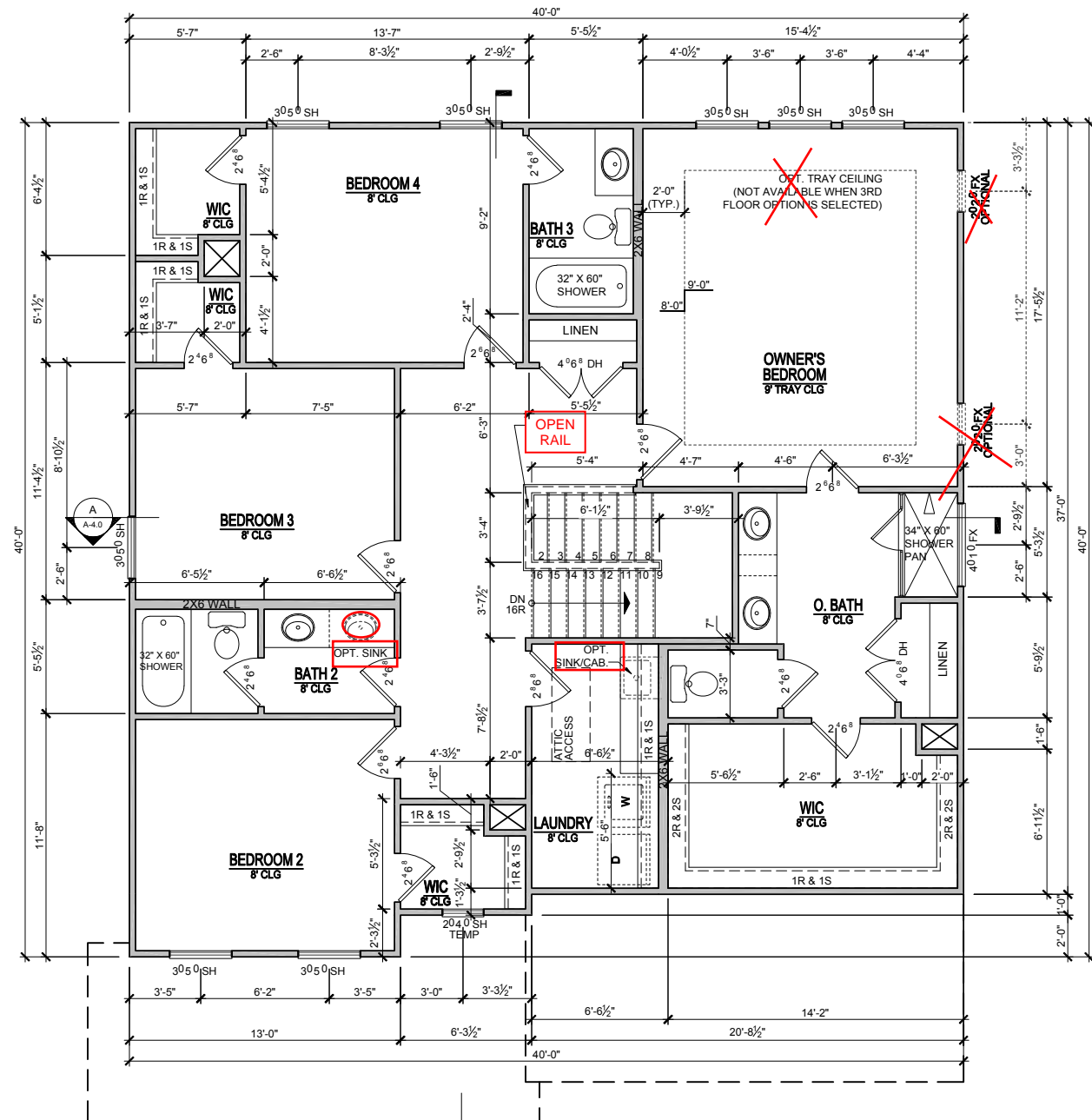

ELEVATION - E 2nd FLOOR PLAN
 SCALE: 1/8"=1'-0" (11"x17" SHEET SIZE)
 SCALE: 1/4"=1'-0" (22"x34" SHEET SIZE)

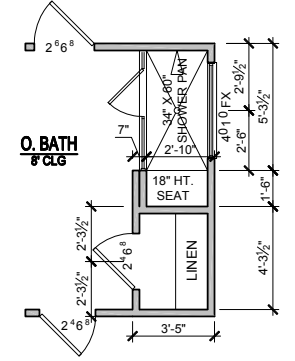

OPT. SPA SHOWER
 SCALE: 1/8"=1'-0" (11"x17" SHEET SIZE)
 SCALE: 1/4"=1'-0" (22"x34" SHEET SIZE)

ELEVATIONS "D-F"	
MODEL HICKORY	REVISION NUMBER 2-26-2020 PROTOTYPE REVISIONS
DRAWING TITLE SECOND FLOOR PLAN	3-13-2020 ADDED BASEMENT FOUNDATION
OPTION DESCRIPTION OPT. 3rd FLOOR ELEVATION - E	7/1/2020 UPDATED SHOWER OPTIONS
SHEET NO. A-2.0E	10/12/2020 ELECTRICAL GARAGE LIGHT ELEV B
	10/23/2020 ADDED GAR SVR DR TO 3RD CAR
	3/29/2021 REVISIONS TO WH & GARAGE DOORS

MAIN STREET DESIGN
 Main Street Designs of Georgia, LLC
 www.MainStreetDesigns.com
 3060 Royal Blvd. South, Suite 135
 Alpharetta, GA 30022
 O. (404) 996-5722

DAVIDSON HOMES
 Your Community Builder

1/8" = 1'-0"

RELEASE DATE 03-29-2021	PROJECT NUMBER -----
OPTION NO. -----	

**COVERED PORCH
ROOF PLAN**
SCALE: 1/16"=1'-0" (11"x17" SHEET SIZE)
SCALE: 1/8"=1'-0" (22"x34" SHEET SIZE)

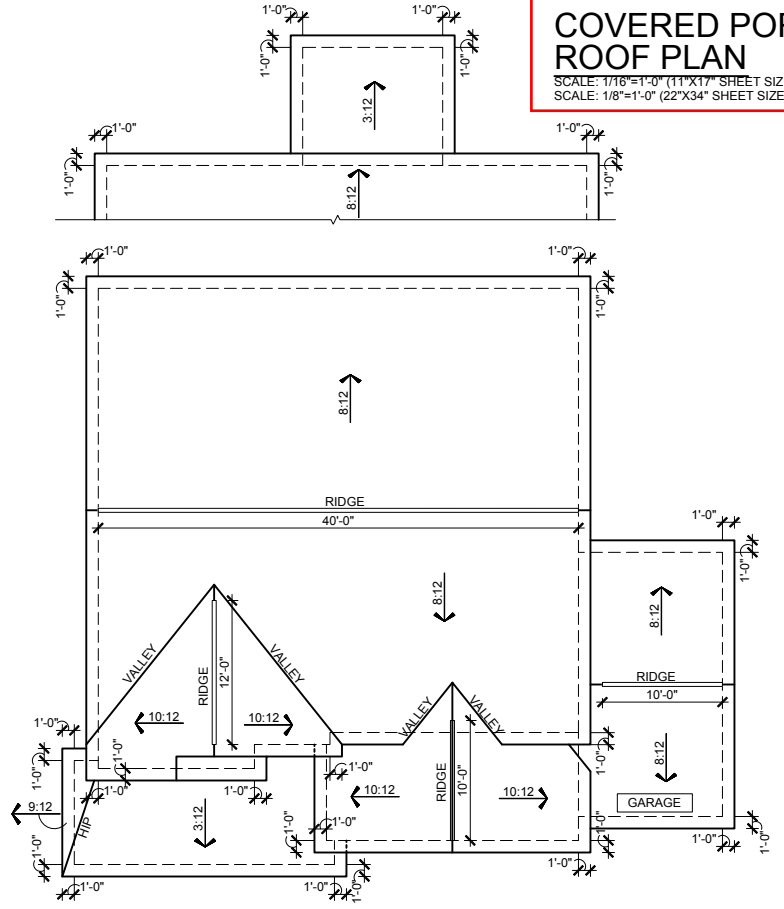

**3rd CAR GARAGE
ELEVATION - E- ROOF PLAN**
SCALE: 1/16"=1'-0" (11"x17" SHEET SIZE)
SCALE: 1/8"=1'-0" (22"x34" SHEET SIZE)

**PRINCE
PLACE
LOT 50**

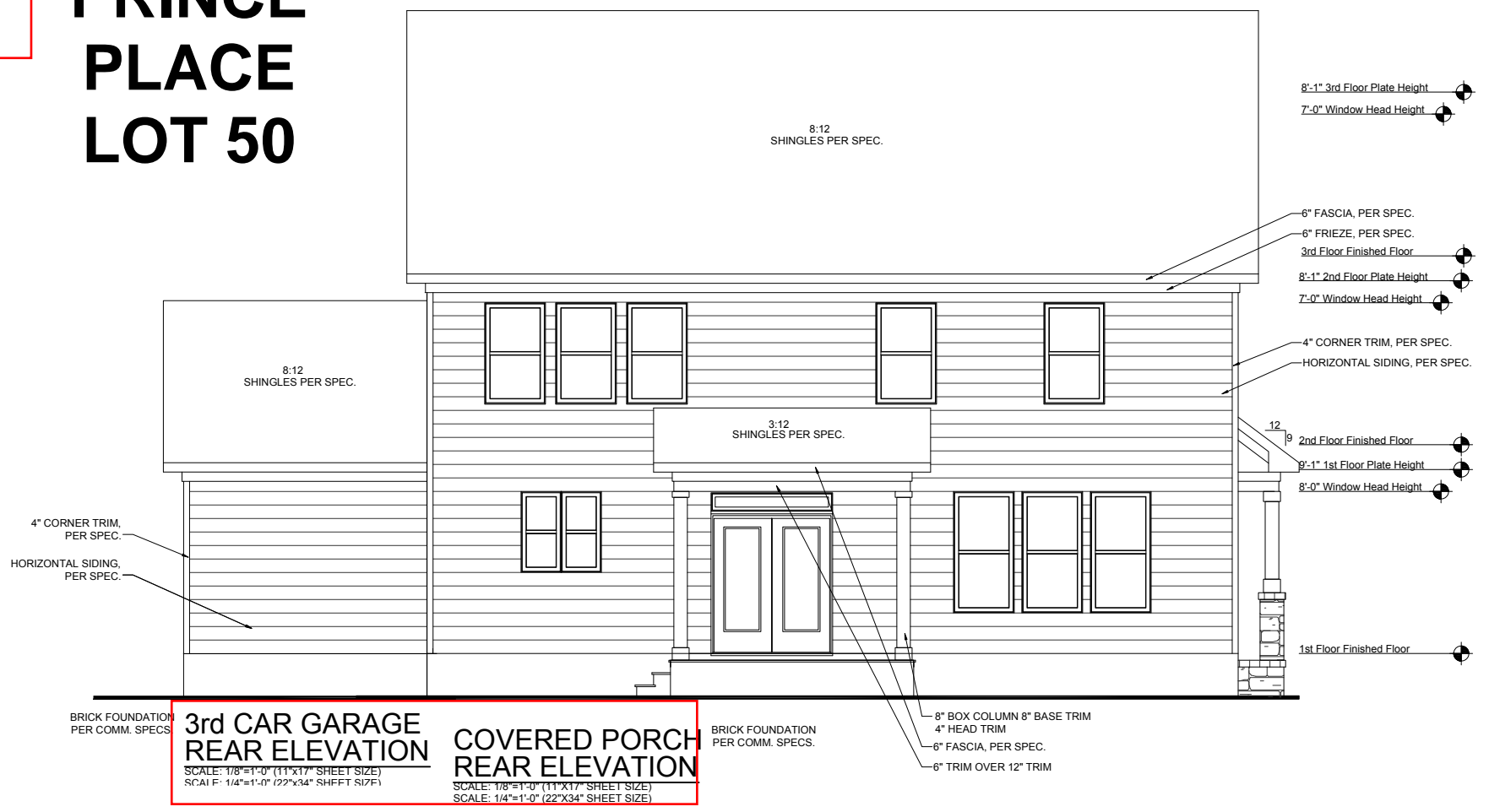

**3rd CAR GARAGE
REAR ELEVATION**
SCALE: 1/8"=1'-0" (11"x17" SHEET SIZE)
SCALE: 1/4"=1'-0" (22"x34" SHEET SIZE)

**COVERED PORCH
REAR ELEVATION**
SCALE: 1/8"=1'-0" (11"x17" SHEET SIZE)
SCALE: 1/4"=1'-0" (22"x34" SHEET SIZE)

ATTIC VENT CALCULATIONS

NOTES:

- GENERAL CONTRACTOR SHALL VERIFY THE NET FREE VENTILATION OF THE VENT PRODUCT SELECTED BY OWNER. VERIFY WITH MANUFACTURER OF HIGH AND LOW VENTS TO BE USED FOR MINIMUM CALCULATED VENTS REQUIRED. THE REQUIRED VENTILATION SHALL BE MAINTAINED. PROVIDE INSULATION STOP SUCH THAT INSULATION DOES NOT OBSTRUCT FREE AIR MOVEMENT AS REQUIRED BY THE BUILDING OFFICIAL. ALL OVERLAP FRAMED ROOF AREAS SHALL HAVE OPENINGS BETWEEN THE ADJACENT ATTICS IN THE ROOF SHEATHING (AS ALLOWED BY THE STRUCTURAL ENGINEER) TO ALLOW PASSAGE AND ATTIC VENTILATION BETWEEN THE TWO OR ISOLATED ATTIC SPACES SHALL BE VENTED INDEPENDENTLY TO CBC REQUIREMENTS.
- PER DEVELOPER, AT ALL CANTILEVERED FLOORS, CANTILEVERED ARCHITECTURAL POP-OUTS, AND ANY DOUBLE FRAMING PROJECTIONS THAT ARE SEPARATED FROM THE VENTING CALCULATIONS SHOWN ABOVE, PROVIDE A CONTINUOUS 2" CORROSION RESISTANT SOFFIT VENT AT UNDERSIDE OF FRAMED ELEMENT.
- ALL ROOF DRAINAGE SHALL BE PIPED TO STREET OR APPROVED DRAINAGE FACILITY.
- DASHED LINES INDICATE WALL BELOW.
- LOCATE GUTTER AND DOWNSPOUTS PER BUILDER.
- PITCHED ROOFS AS NOTED.
- TRUSS MANUFACTURER SHALL SUBMIT STRUCTURAL CALCS AND SHOP DRAWINGS TO THE BUILDER'S GENERAL CONTRACTOR AND BUILDING DEPARTMENT FOR REVIEW PRIOR TO FABRICATIONS.
- ALL PLUMBING VENTS SHALL BE COMBINED INTO A MINIMUM AMOUNT OF ROOF PENETRATIONS. ALL ROOF PENETRATIONS SHALL OCCUR TO THE REAR OF THE MAIN RIDGE

MAIN ROOF

1525 SQ FT UNDER ROOF ATTIC	300 SQ FT / 1 SQ FT = 5.08 SQ FT VENTILATION
RIDGE VENTS 18 SQ IN = (.125 SQ FT)	SOFFIT VENTS 9 SQ IN = (.0625 SQ FT)
BOX VENTS 50 SQ IN = (.347 SQ FT)	
5.08 SQ FT x 50% = 2.542 SQ FT OF RIDGE	2.542 SQ FT OF SOFFIT
5.08 SQ FT x 50% = 2.542 SQ FT OF RIDGE	2.542 SQ FT OF SOFFIT

3rd CAR GARAGE ROOF

264 SQ FT UNDER ROOF ATTIC	300 SQ FT / 1 SQ FT = 0.88 SQ FT VENTILATION
RIDGE VENTS 18 SQ IN = (.125 SQ FT)	SOFFIT VENTS 9 SQ IN = (.0625 SQ FT)
BOX VENTS 50 SQ IN = (.347 SQ FT)	
0.88 SQ FT x 50% = 0.440 SQ FT OF RIDGE	0.440 SQ FT OF SOFFIT
0.88 SQ FT x 50% = 0.440 SQ FT OF RIDGE	0.440 SQ FT OF SOFFIT

PORCH ROOF

115 SQ FT UNDER ROOF	150 SQ FT / 1 SQ FT = 0.77 SQ FT VENTILATION
SOFFIT VENTS 9 SQ IN = (.0625 SQ FT)	ASSUME 100% VENTING @ SOFFIT
SOFFIT VENT	0.767 SQ FT = 12.3 FEET OF SOFFIT VENT
0.0625 SQ FT	
ACTUAL SOFFIT VENT PROVIDED	13 FEET

PORCH ROOF

183 SQ FT UNDER ROOF	150 SQ FT / 1 SQ FT = 1.22 SQ FT VENTILATION
SOFFIT VENTS 9 SQ IN = (.0625 SQ FT)	ASSUME 100% VENTING @ SOFFIT
SOFFIT VENT	1.220 SQ FT = 19.5 FEET OF SOFFIT VENT
0.0625 SQ FT	
ACTUAL SOFFIT VENT PROVIDED	33 FEET

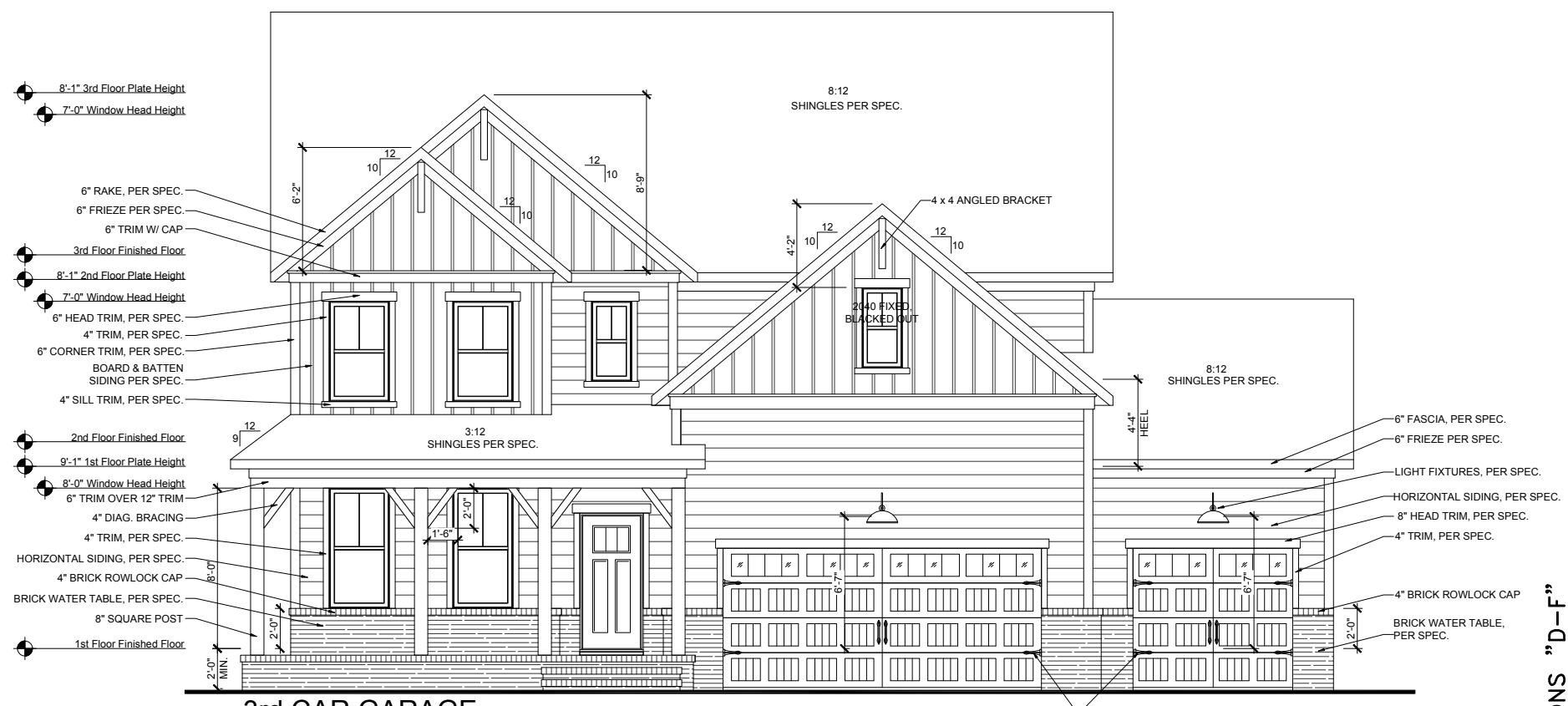

**3rd CAR GARAGE
FRONT ELEVATION - E**
SCALE: 1/8"=1'-0" (11"x17" SHEET SIZE)
SCALE: 1/4"=1'-0" (22"x34" SHEET SIZE)

REVISION NUMBER	PROTOTYPE REVISIONS
2-26-2020	ADDED BASEMENT FOUNDATION
3-13-2020	UPDATED SHOWER OPTIONS
7/1/2020	ELECTRICAL GARAGE LIGHT ELEV B
10/12/2020	ADDED GAR SVR DR TO 3RD CAR
10/23/2020	REVISIONS TO WH & GARAGE DOORS
3/29/2021	

MAIN STREET DESIGN
Main Street Designs of Georgia, LLC
www.MainStreetDesignsLLC.com
3050 Royal Blvd. South, Suite 135
Alpharetta, GA 30022
O. (404) 996-5722

**DAVIDSON
HOMES**
Your Community Builder

1/8"=1'-0"
RELEASE DATE 03-29-2021
PROJECT NUMBER -----
OPTION NO. -----

ELEVATIONS "D-F"

MODEL HICKORY	DRAWING TITLE PLAN OPTIONS
SHEET NO. O-2.1E	OPTION DESCRIPTION 3 CAR GARAGE - E

PRINCE PLACE LOT 50

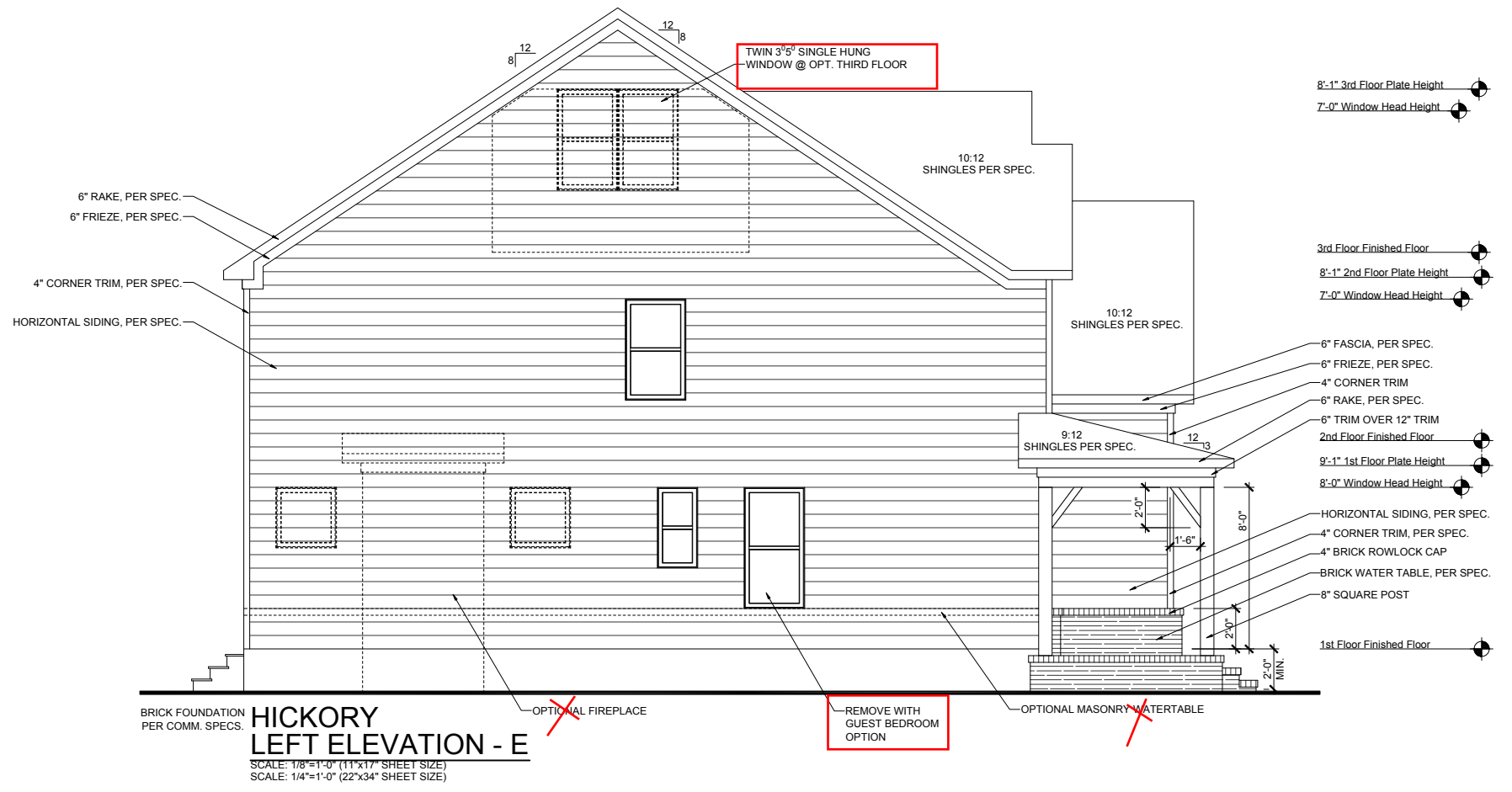
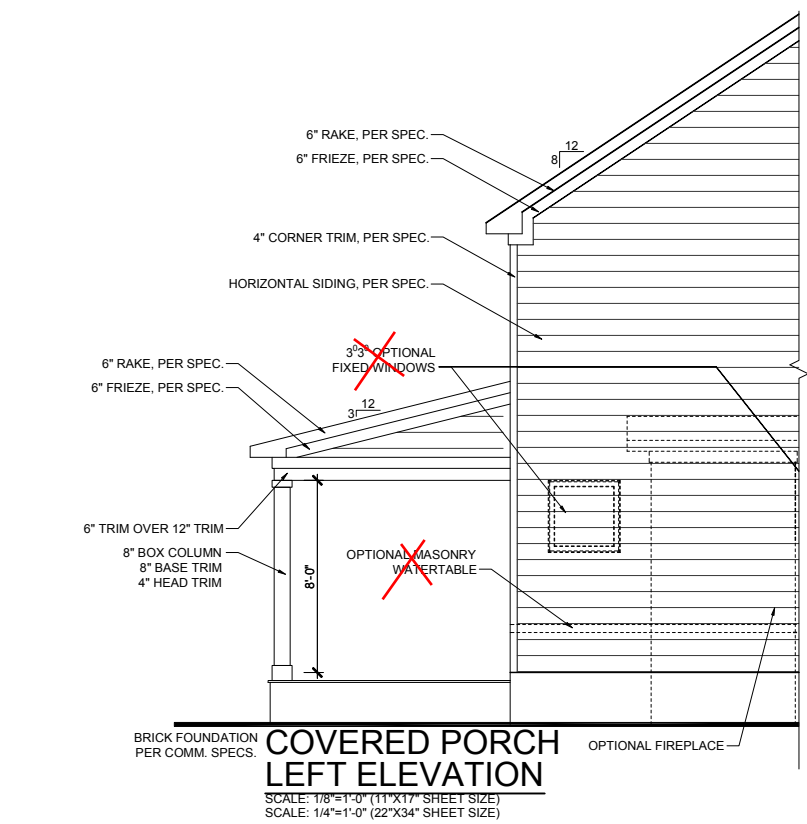
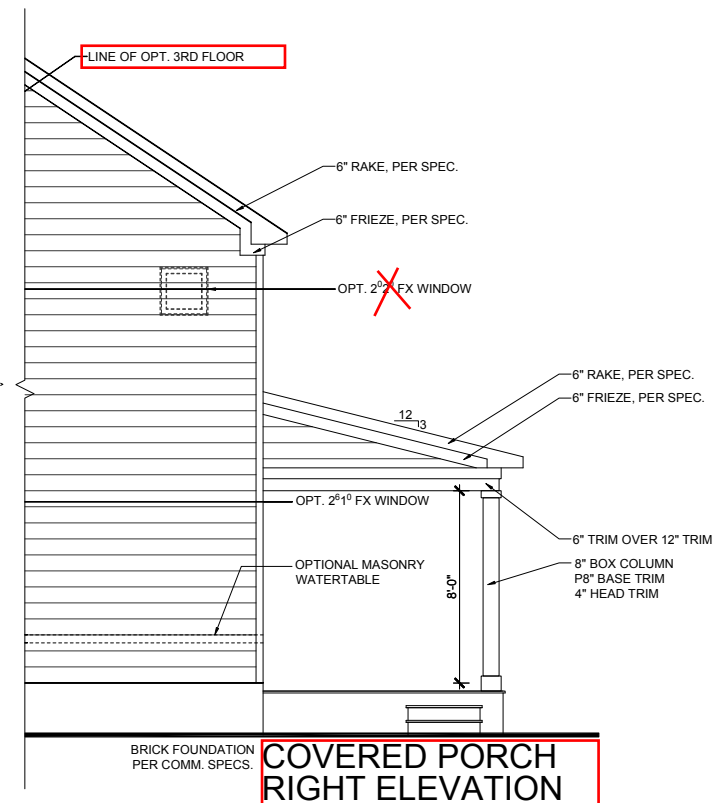
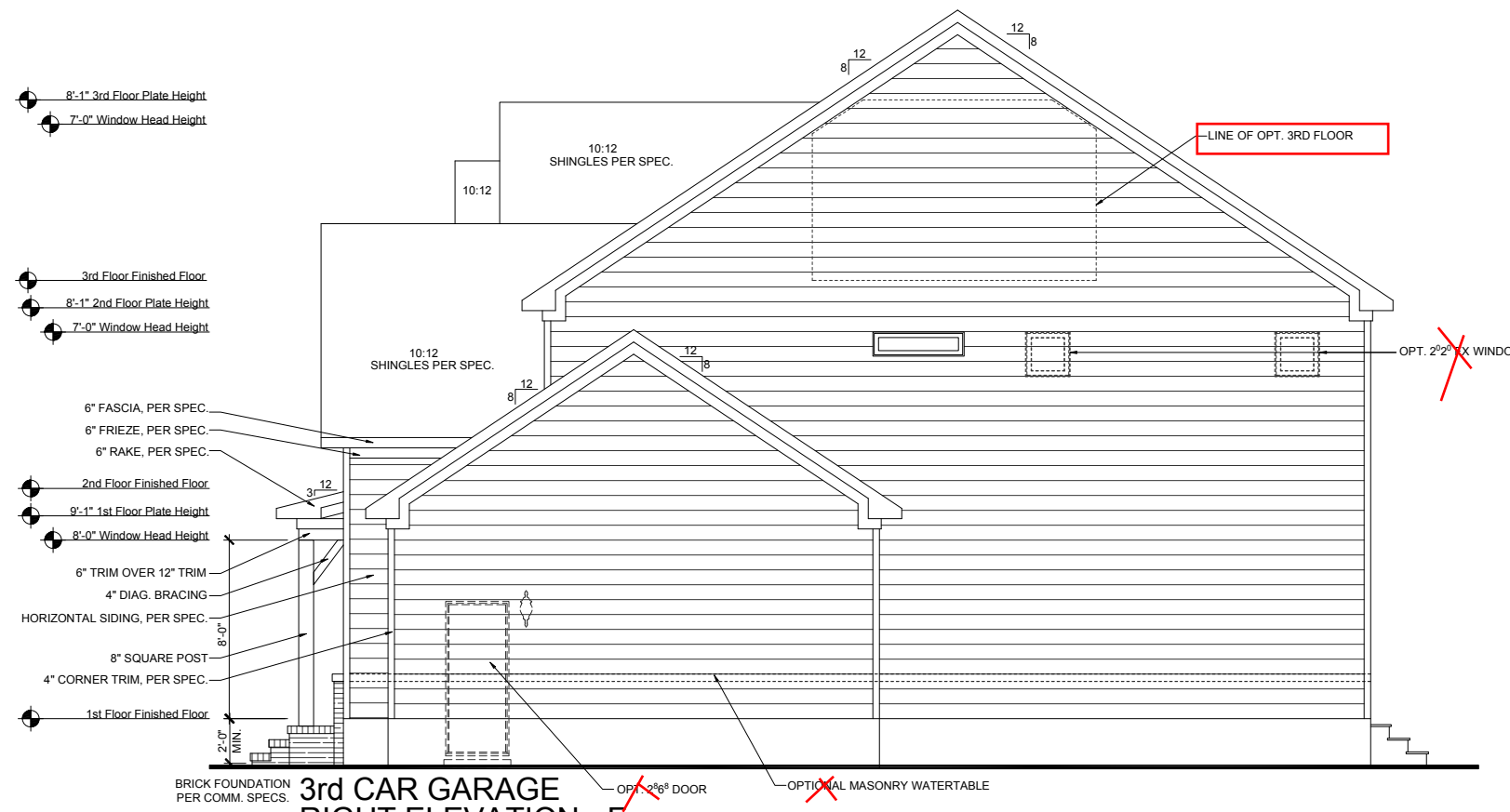

REVISION NUMBER		2-26-2020	PROTOTYPE REVISIONS
3-13-2020		ADDED BASEMENT FOUNDATION	
7/1/2020		UPDATED SHOWER OPTIONS	
10/12/2020		ELECTRICAL GARAGE LIGHT ELEV B	
10/23/2020		ADDED GAR SVR DR TO 3RD CAR	
3/29/2021		REVISIONS TO WH & GARAGE DOORS	
Main Street Designs of Georgia, LLC www.MainStreetDesignsLLC.com 3650 Royal Blvd. South, Suite 135 Alpharetta, GA 30022 O. (404) 996-5722			
DAVIDSON HOMES Your Community Builder			
RELEASE DATE		1/8" = 1'-0"	
03-29-2021			
PROJECT NUMBER		OPTION NO.	
---		---	
MODEL		DRAWING TITLE	
HICKORY		SIDE ELEVATIONS	
SHEET NO.		OPTION DESCRIPTION	
A-3.1E		ELEVATION - E	

ELEVATIONS "D-F"

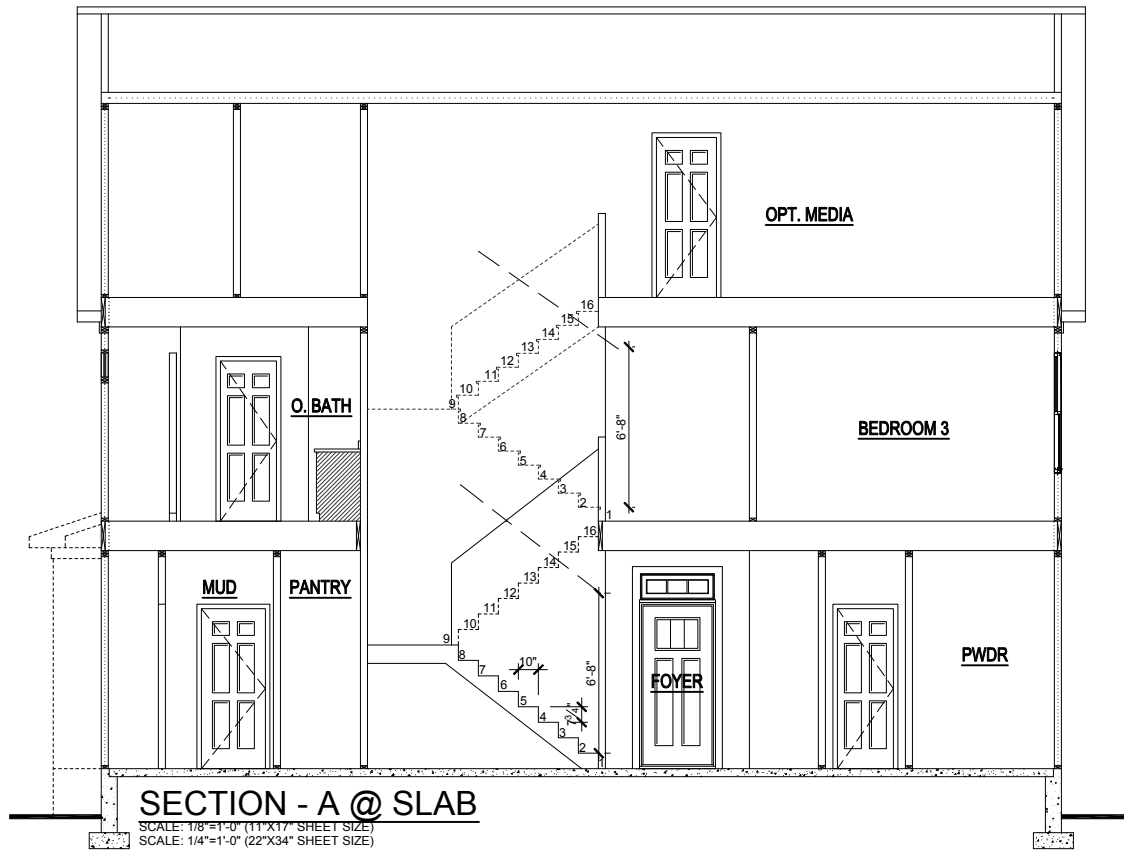

8'-1" 3rd Floor Plate Height
 7'-0" Window Head Height

3rd Floor Finished Floor
 8'-1" 2nd Floor Plate Height
 7'-0" Window Head Height

2nd Floor Finished Floor
 9'-1" 1st Floor Plate Height
 8'-0" Window Head Height

1st Floor Finished Floor

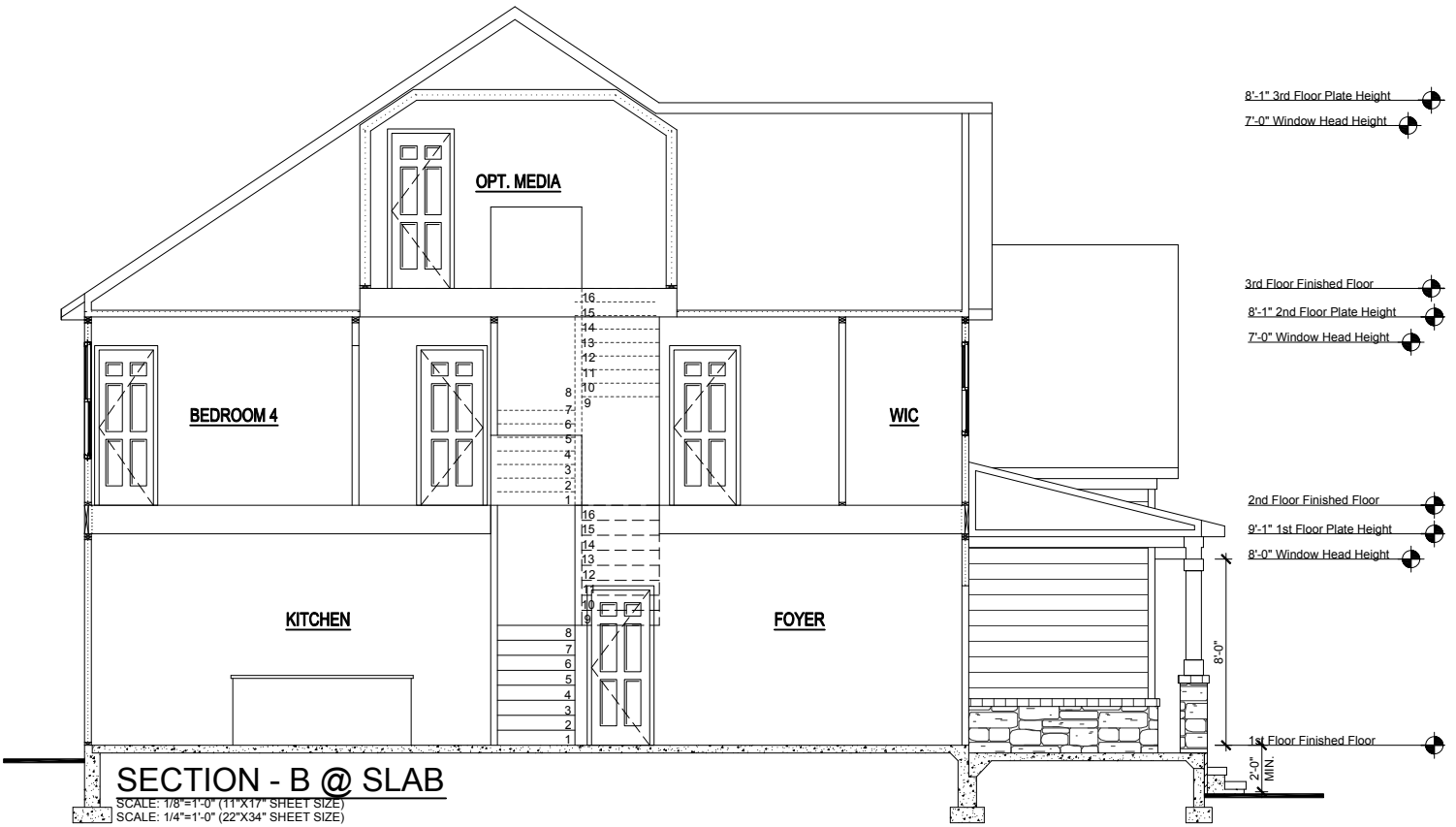

8'-1" 3rd Floor Plate Height
 7'-0" Window Head Height

3rd Floor Finished Floor
 8'-1" 2nd Floor Plate Height
 7'-0" Window Head Height

2nd Floor Finished Floor
 9'-1" 1st Floor Plate Height
 8'-0" Window Head Height

1st Floor Finished Floor

REVISION NUMBER	PROTOTYPE REVISIONS
2-26-2020	ADDED BASEMENT FOUNDATION
3-13-2020	UPDATED SHOWER OPTIONS
7/1/2020	ELECTRICAL GARAGE LIGHT ELEV B
10/12/2020	ADDED GAR SVR DR TO 3RD CAR
10/23/2020	REVISIONS TO WH & GARAGE DOORS
3/29/2021	

MAIN STREET DESIGN
 Main Street Designs of Georgia, LLC
 www.MainStreetDesign.com
 3050 Royal Blvd. South, Suite 135
 Alpharetta, GA 30022
 O. (404) 996-5722



RELEASE DATE	03-29-2021
PROJECT NUMBER	-----
OPTION NO.	-----

MODEL	HICKORY
DRAWING TITLE	BUILDING SECTIONS
OPTION DESCRIPTION	

SHEET NO.
A-4.0E

ELECTRICAL KEY

- CEILING RECEP.
- DUPLEX RECEP.
- SPLIT SWITCHED RECEP.
- FLOOR RECEP.
- QUADPLEX RECEP.
- GFI
- GFI/WP
- WEATHER PROOF RECEP.
- 220V
- 220V RECEP.
- EXHAUST FAN
- EXHAUST FAN / LIGHT
- EXHAUST FAN / HEAT LIGHT
- LED
- VAPOR PROTECTED LIGHT
- CEILING LIGHT
- HANGING CEILING LIGHT
- WALL LIGHT
- WALL SCONCE LIGHT
- SINGLE SWITCH
- 3-WAY SWITCH
- 4-WAY SWITCH
- DIMMER SWITCH
- CABLE T.V. JACK
- BUTTON
- PHONE JACK
- DIRECT WIRE
- SECURITY SYSTEM PHONE JACK
- SMOKE DETECTOR
- CARBON MONOXIDE DETECTOR
- ELECTRICAL PANEL
- DISCONNECT SWITCH
- ELECTRIC METER
- 1 TUBE FLUORESCENT
- 2 TUBE FLUORESCENT
- FLOOD LIGHT
- CHIMES
- CEILING FAN
- CEILING FAN W/ LIGHT

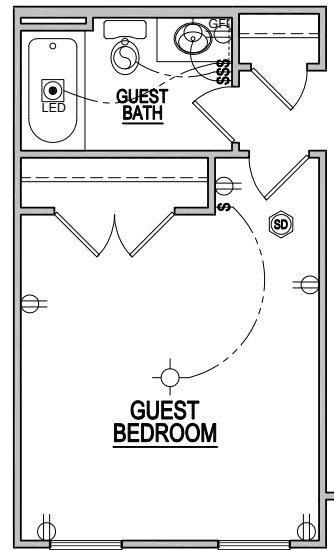

GUEST BEDROOM ILO SUDY

SCALE: 1/8"=1'-0" (11"x17" SHEET SIZE)
SCALE: 1/4"=1'-0" (22"x34" SHEET SIZE)

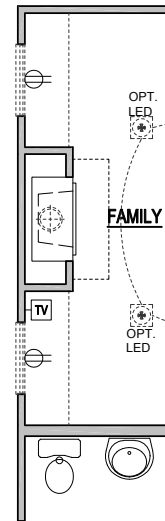

1st FLOOR PLAN OPT. FIREPLACE- 'B'

SCALE: 1/8"=1'-0" (11"x17" SHEET SIZE)
SCALE: 1/4"=1'-0" (22"x34" SHEET SIZE)

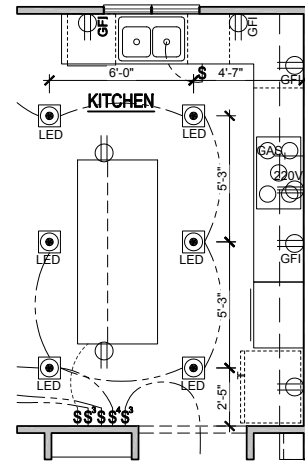

GOURMET KITCHEN

SCALE: 1/8"=1'-0" (11"x17" SHEET SIZE)
SCALE: 1/4"=1'-0" (22"x34" SHEET SIZE)

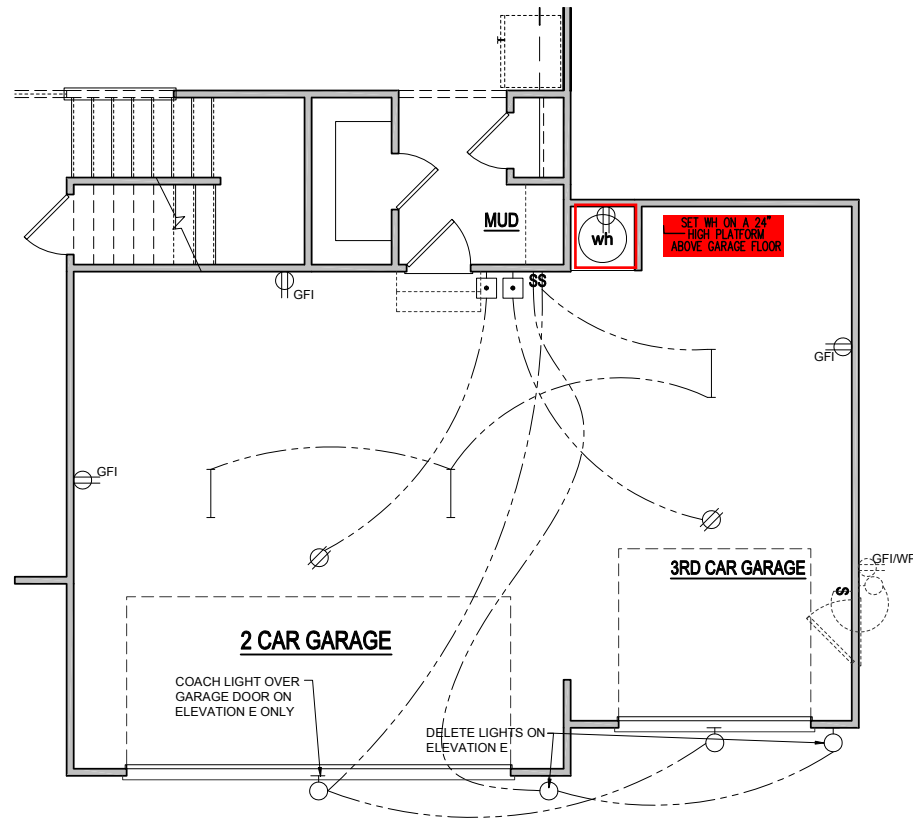

OPT. THREE CAR GARAGE 1st FLOOR ELECTRICAL PLAN

SCALE: 1/8"=1'-0" (11"x17" SHEET SIZE)
SCALE: 1/4"=1'-0" (22"x34" SHEET SIZE)

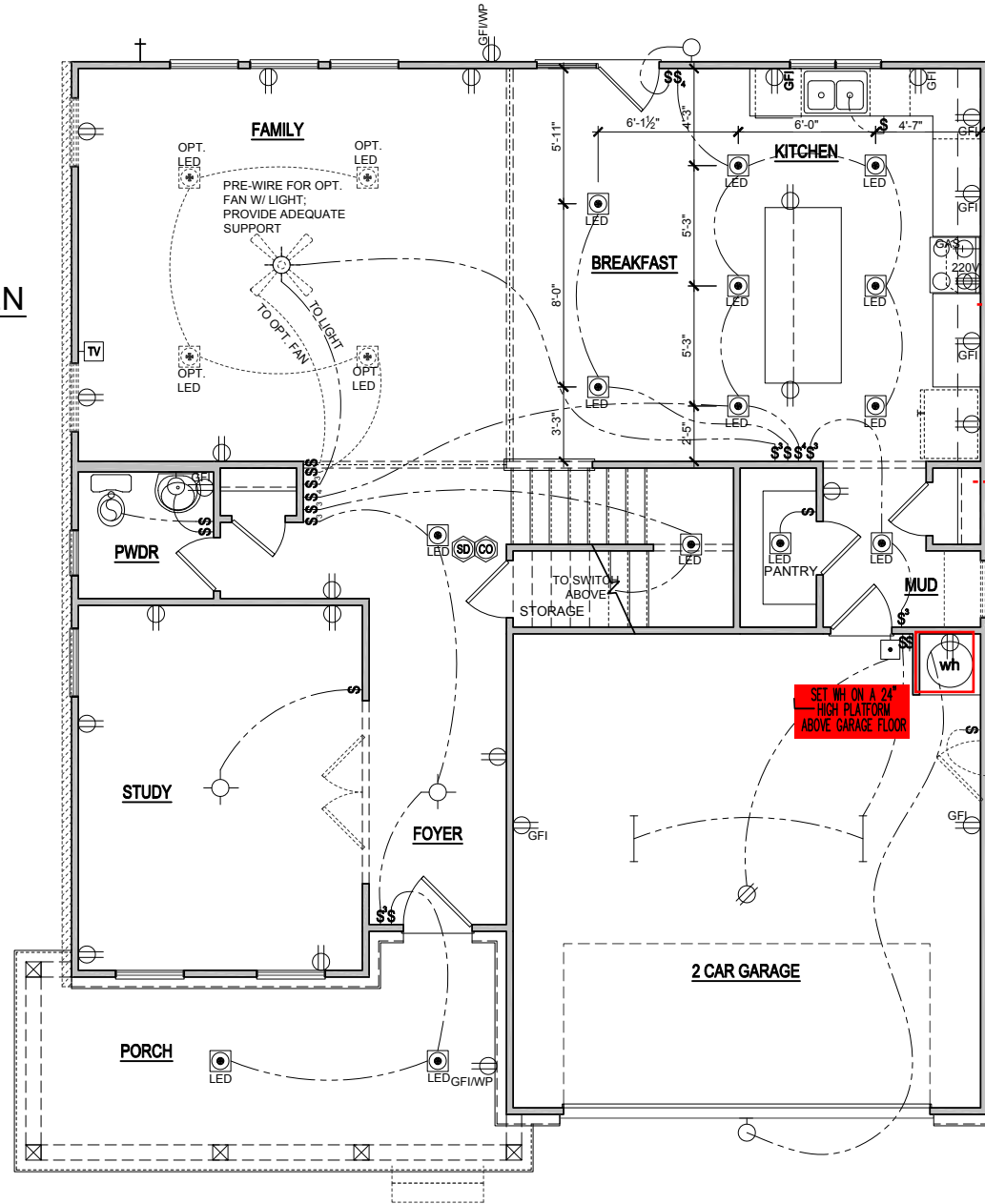

ELEVATION - E FIRST FLOOR ELECTRICAL PLAN

SCALE: 1/8"=1'-0" (11"x17" SHEET SIZE)
SCALE: 1/4"=1'-0" (22"x34" SHEET SIZE)

PRINCE PLACE LOT 50

PROpane TANK

REVISION NUMBER	PROTOTYPE REVISIONS
2-26-2020	ADDED BASEMENT FOUNDATION
3-13-2020	UPDATED SHOWER OPTIONS
7/1/2020	ELECTRICAL GARAGE LIGHT ELEV B
10/12/2020	ADDED GAR SVR DR TO 3RD CAR
3/29/2021	REVISIONS TO WH & GARAGE DOORS

MAIN STREET DESIGN
Main Street Designs of Georgia, LLC
www.MainStreetDesigns.com
3650 Royal Blvd. South, Suite 135
Alpharetta, GA 30022
O. (404) 996-5722

DAVIDSON HOMES
Your Community Builder

RELEASE DATE	1/8"=1'-0"
03-29-2021	
PROJECT NUMBER	
OPTION NO.	

MODEL	HICKORY
DRAWING TITLE	1ST FLOOR ELEC. PLAN
OPTION DESCRIPTION	ELEVATION - E

SHEET NO. **E-1.0E**

ELEVATIONS "D-F"

PRINCE PLACE LOT 50

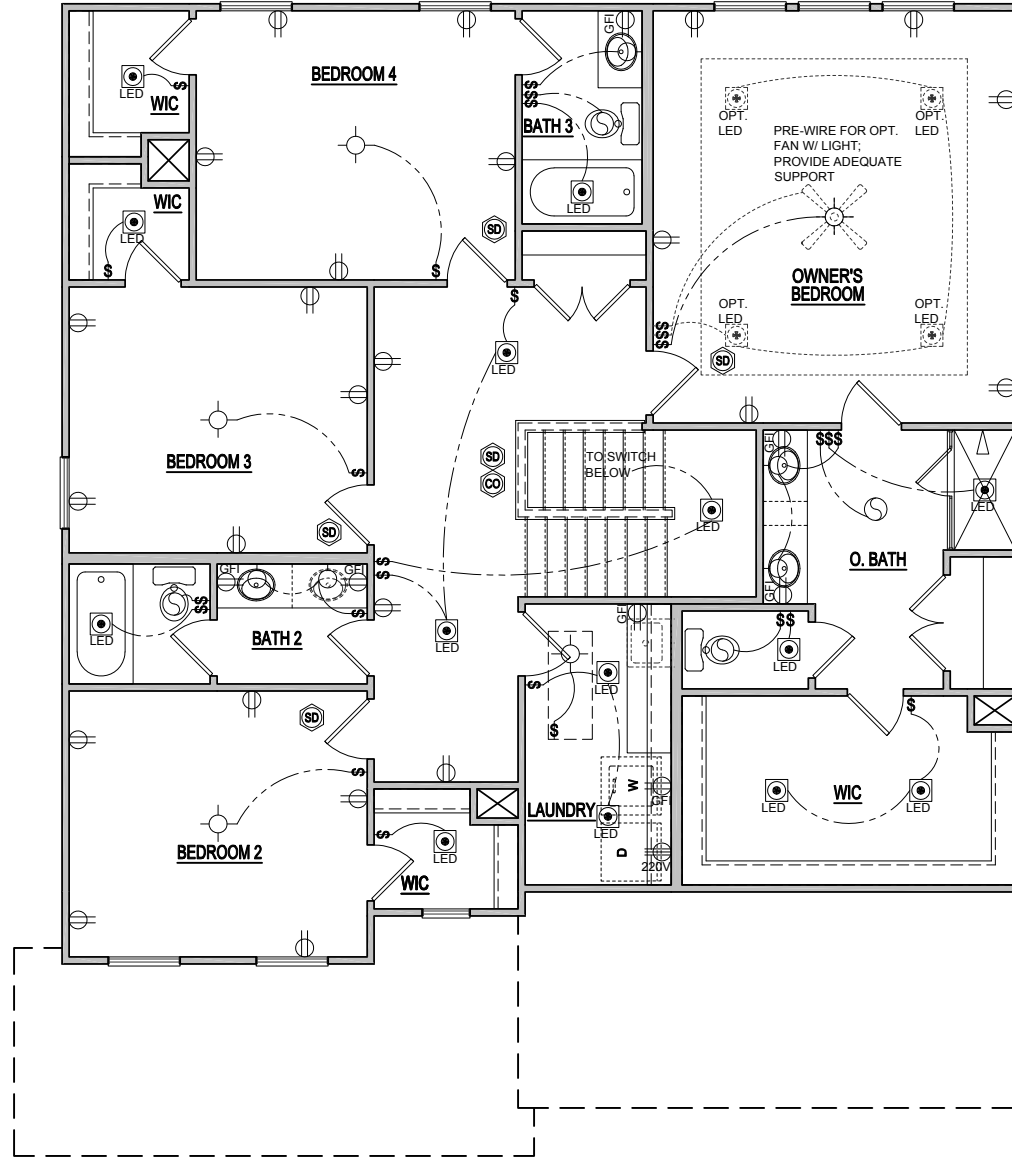
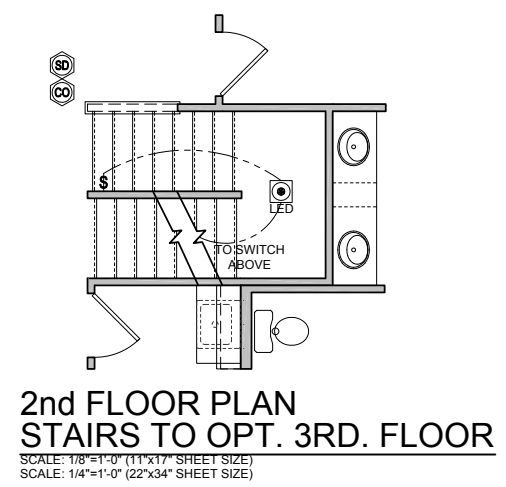
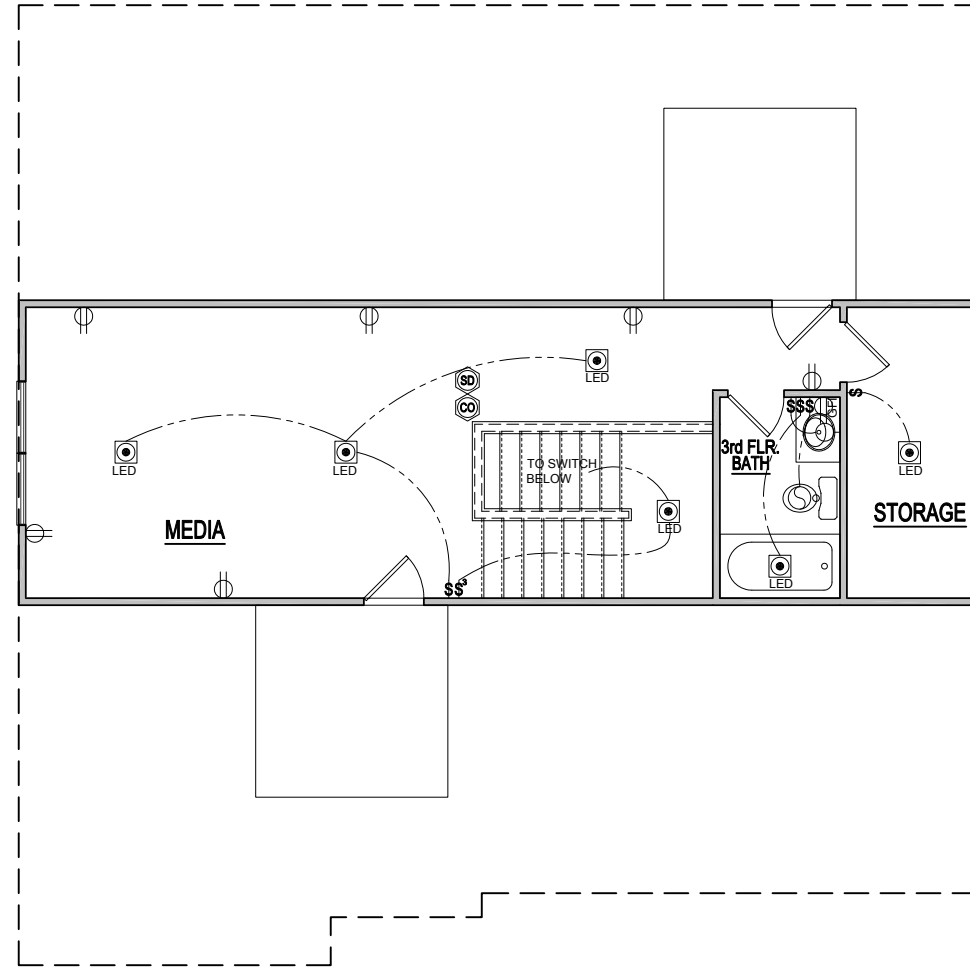

**ELEVATION - E
SECOND FLOOR ELECTRICAL PLAN**
SCALE: 1/8"=1'-0" (11"x17" SHEET SIZE)
SCALE: 1/4"=1'-0" (22"x34" SHEET SIZE)

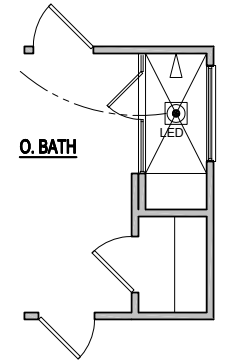

OPT. SPA SHOWER
SCALE: 1/8"=1'-0" (11"x17" SHEET SIZE)
SCALE: 1/4"=1'-0" (22"x34" SHEET SIZE)

REVISION NUMBER	PROTOTYPE REVISIONS
2-26-2020	ADDED BASEMENT FOUNDATION
3-13-2020	UPDATED SHOWER OPTIONS
7/1/2020	ELECTRICAL GARAGE LIGHT ELEV B
10/12/2020	ADDED GAR SVR DR TO 3RD CAR
10/23/2020	REVISIONS TO WH & GARAGE DOORS
3/29/2021	

MAIN STREET DESIGN
Main Street Designs of Georgia, LLC
www.MainStreetDesigns.com
3650 Royal Blvd. South, Suite 135
Alpharetta, GA 30022
O. (404) 996-5722

DAVIDSON HOMES
Your Community Builder

RELEASE DATE	1/8"=1'-0"
03-29-2021	
PROJECT NUMBER	
OPTION NO.	

ELEVATIONS "D-F"

MODEL	HICKORY
DRAWING TITLE	SECOND FLOOR PLAN
OPTION DESCRIPTION	ELEVATION - E

SHEET NO.
E-2.0E

**120 MPH ULTIMATE DESIGN WIND SPEED
NOTES FOR LESS THAN
30' MEAN ROOF HEIGHT:**

- ENGINEER'S SEAL APPLIES ONLY TO STRUCTURAL COMPONENTS. ENGINEER'S SEAL DOES NOT CERTIFY DIMENSIONAL ACCURACY OR ARCHITECTURAL LAYOUT INCLUDING ROOF SYSTEM.
- STRUCTURAL DESIGN PER NORTH CAROLINA RESIDENTIAL CODE, 2018 EDITION.
- INSTALL 1/2" ANCHOR BOLTS 6'-0" O.C. AND WITHIN 1'-0" FROM END OF EACH CORNER. ANCHOR BOLTS MUST EXTEND A MINIMUM OF 1" INTO MASONRY OR CONCRETE. LOCATE BOLT WITHIN MIDDLE THIRD OF PLATE WIDTH. MEAN ROOF HEIGHT IS LESS THAN 30 FEET.
- EXTERIOR WALLS DESIGNED FOR 120 MPH WINDS.
- WALL CLADDING DESIGNED FOR +5.5 PSF AND -20 PSF (+/- INDICATE POSITIVE / NEGATIVE PRESSURE (TYP)).
- ROOF CLADDING DESIGNED FOR 44.2 PSF AND -18 PSF FOR ROOF PITCHES 1/2 TO 1/12 AND 40 PSF AND -36 PSF FOR ROOF PITCHES 2.25 TO 1/12.
- INSTALL 7/8" OSB SHEATHING ON ALL EXTERIOR WALLS OF ALL STORES IN ACCORDANCE WITH SECTION R602.10.3 OF THE NRC, 2018 EDITION. SEE THE WALL BRACING NOTES AND DETAILS SHEET FOR MORE INFORMATION.
- ENERGY EFFICIENCY COMPLIANCE AND INSULATION VALUES OF THE BUILDING TO BE IN ACCORDANCE WITH CHAPTER 11 OF THE NRC, 2018 EDITION.
- REFER TO NOTES AND DETAIL SHEETS FOR ADDITIONAL STRUCTURAL INFORMATION.

PRINCE PLACE LOT 50

SCALE NOTE:
LARGE FORMAT PRINTS ARE TO SCALE AS NOTED.
11" x 17" PRINTS ARE ONE HALF THE NOTED SCALE



12/29/2022

**J.S. THOMPSON
ENGINEERING, INC**
333 EAST SIX FORKS ROAD, SUITE 180 RALEIGH, NC 27609
PHONE: (919) 789-9919 FAX: (919) 789-9921
N.C. LICENSE NO.: C-1733

- STRUCTURAL NOTES:**
- ALL FRAMING LUMBER TO BE #2 SYP OR #2 SYP (UNO). ALL TREATED LUMBER TO BE #2 SYP (UNO).
 - INSTALL DOUBLE OR TRIPLE JOIST UNDER WALLS PARALLEL TO FLOOR JOISTS WHERE NOTED ON THE PLANS.
 - SQUARES DENOTE POINT LOADS WHICH REQUIRE SOLID BLOCKING TO GIRDER OR FOUNDATION.
 - SHADED PIERS TO BE FILLED SOLID.
 - INSTALL LADDER WIRE #16" O.C. TO SECURE MULTIPLE WYTHE FOUNDATION WALLS TOGETHER. REFER TO NOTES AND DETAIL SHEETS FOR ADDITIONAL STRUCTURAL INFORMATION.

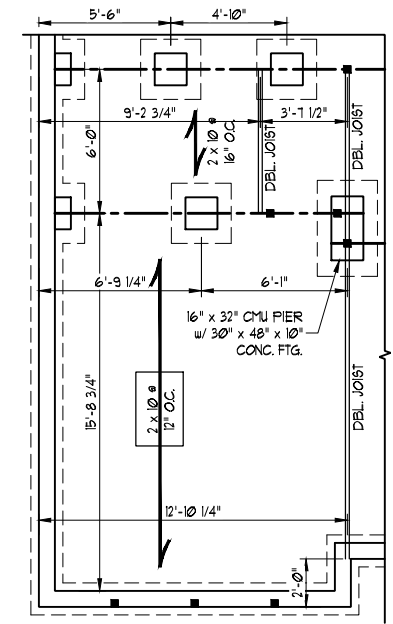

OPTIONAL BEDROOM 5/BATHROOM 4
(SEE ELEVATION FOR PORCH CONFIGURATION)

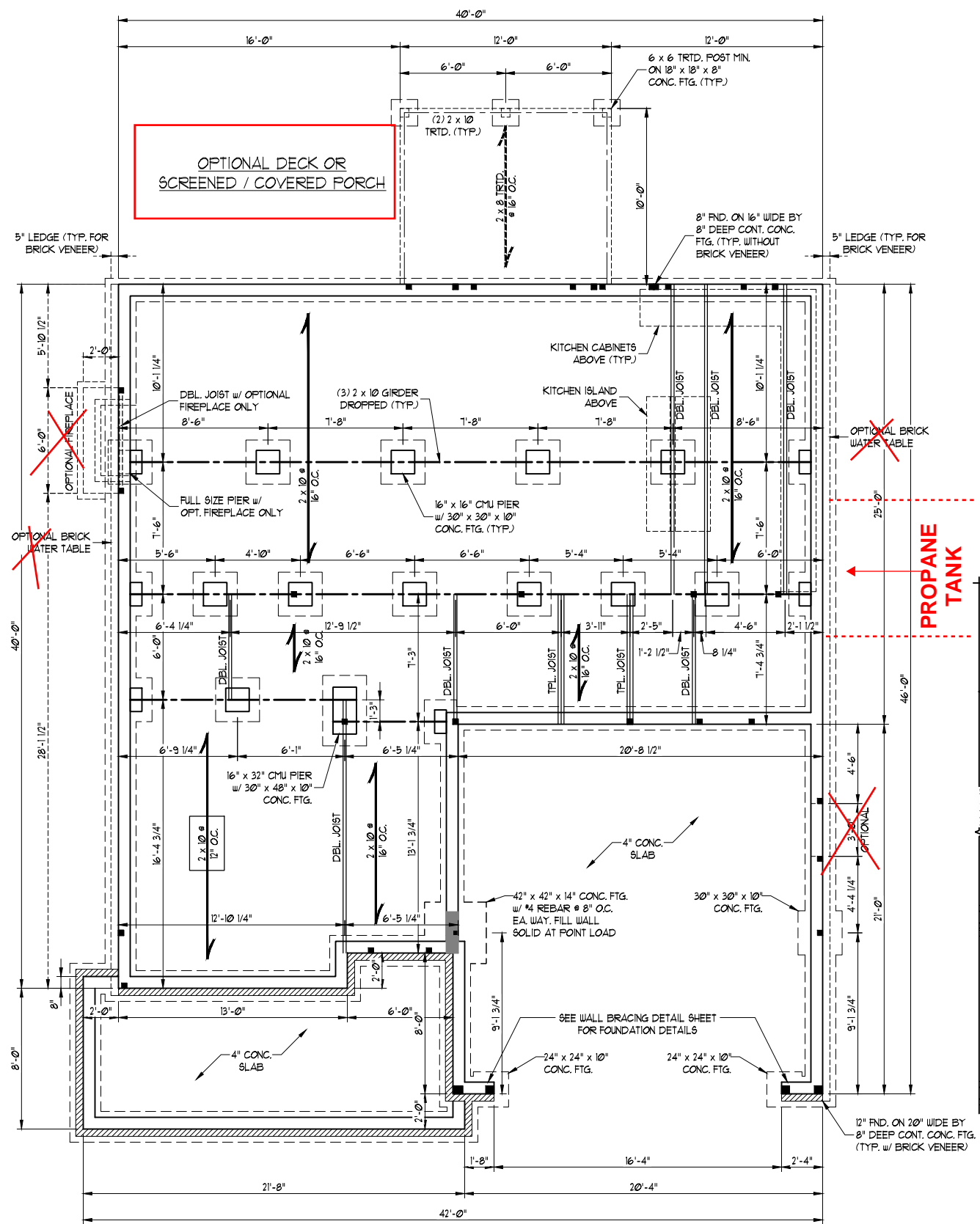

ELEVATION E

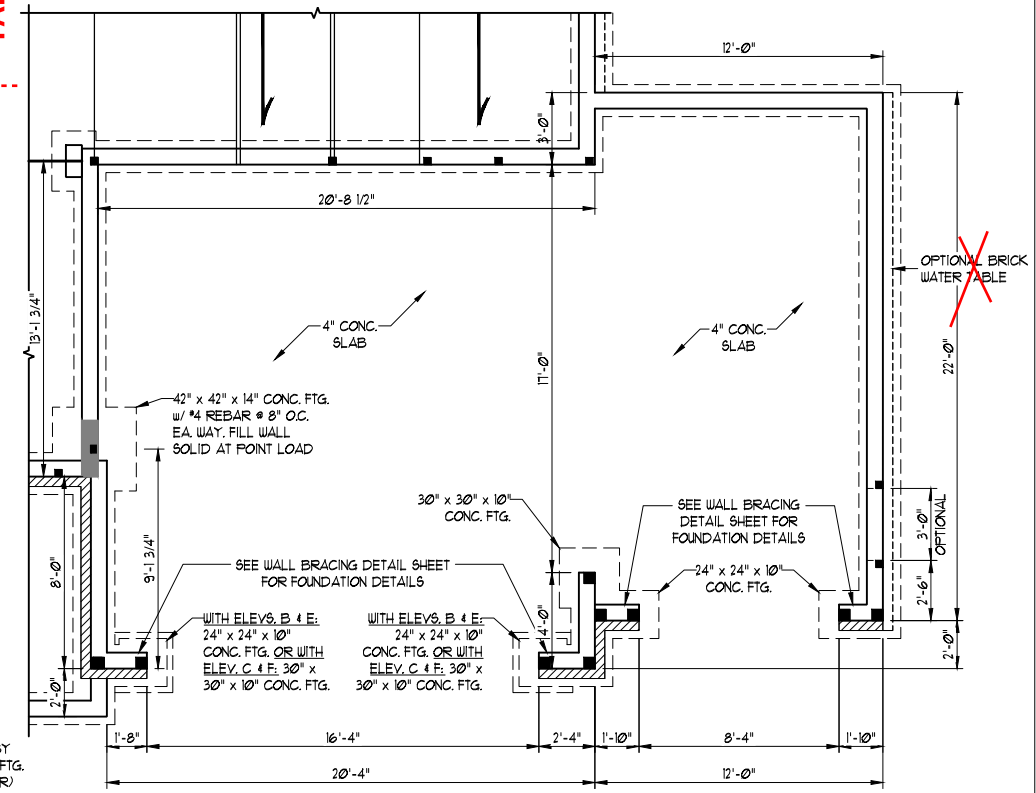

OPTIONAL THIRD CAR GARAGE
ELEVATIONS B, C, E, & F
(ONLY AVAILABLE w/ FRONT LOAD GARAGE)

HICKORY HOMES
DAVIDSON HOMES

DATE: DECEMBER 29, 2022
SCALE: 1/4" = 1'-0"
DRAWN BY: MAIN STREET DESIGNS
ENGINEERED BY: ZHH

S-1.1n
CRAWL FOUNDATION
PLAN w/ OPT. 2 x 10 JOISTS

SCALE NOTE:
LARGE FORMAT PRINTS ARE TO SCALE AS NOTED.
11" x 17" PRINTS ARE ONE HALF THE NOTED SCALE

PRINCE PLACE LOT 50

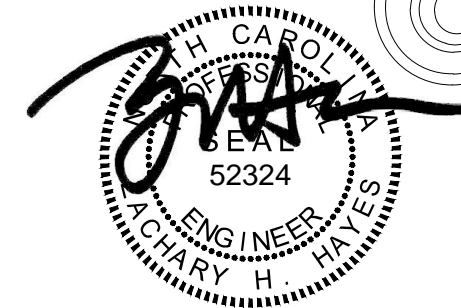

12/29/2022

J.S. THOMPSON ENGINEERING, INC.
333 EAST SIX FORKS ROAD, SUITE 180, RALEIGH, NC 27609
PHONE: (919) 789-9919 FAX: (919) 789-9921
N.C. LICENSE NO. C-1733

HICKORY DAVIDSON HOMES

DATE: DECEMBER 29, 2022
SCALE: 1/4" = 1'-0"
DRAWN BY: MAIN STREET DESIGNS
ENGINEERED BY: ZHH

S-3e
SECOND FLOOR FRAMING PLAN

- STRUCTURAL NOTES:**
- ALL FRAMING LUMBER TO BE 5/8" OR 5/4" (UNO). ALL TREATED LUMBER TO BE 5/4" (UNO).
 - ALL LOAD BEARING HEADERS TO BE (2) 2 x 6 (UNO).
 - INSTALL AN EXTRA JOIST UNDER WALLS PARALLEL TO FLOOR JOISTS WHERE NOTED ON THE PLANS.
 - WINDOW AND DOOR HEADERS TO BE SUPPORTED w/ (1) JACK STUD AND (1) KING STUD EA. END (UNO). SEE TABLE R602.15 FOR ADDITIONAL KING STUD REQUIREMENTS.
 - SQUARES DENOTE POINT LOADS WHICH REQUIRE SOLID BLOCKING TO GIRDER OR FOUNDATION. ALL SQUARES TO BE (2) STUDS (UNO).
 - ALL 4 x 4 POSTS SHALL BE ANCHORED TO SLABS w/ SIMPSON ABU44 POST BASES (OR EQUAL) AND 6 x 6 POSTS w/ ABU66 POST BASES (OR EQUAL) (UNO). ALL 4 x 4 AND 6 x 6 POSTS TO BE INSTALLED WITH 100 LB CAPACITY UPLIFT CONNECTORS AT TOP (UNO).
 - FOR FIBERGLASS, ALUMINUM OR COLUMN ENG. BY OTHERS, SECURE TO SLAB w/ (2) METAL ANGLES USING 2" CONC. SCREWS. FASTEN ANGLES TO COLUMNS w/ 1/4" THROUGH BOLTS w/ NUTS AND WASHERS. LOCATE ANGLES ON OPPOSITE SIDES OF COLUMN. THROUGH BOLTS MUST BE INSTALLED PRIOR TO SETTING COLUMN. REFER TO NOTES AND DETAIL SHEETS FOR ADDITIONAL STRUCTURAL INFORMATION.
 - FOR FIBERGLASS, ALUMINUM OR COLUMN ENG. BY OTHERS, SECURE TO SLAB w/ (2) METAL ANGLES USING 2" CONC. SCREWS. FASTEN ANGLES TO COLUMNS w/ 1/4" THROUGH BOLTS w/ NUTS AND WASHERS. LOCATE ANGLES ON OPPOSITE SIDES OF COLUMN. THROUGH BOLTS MUST BE INSTALLED PRIOR TO SETTING COLUMN. REFER TO NOTES AND DETAIL SHEETS FOR ADDITIONAL STRUCTURAL INFORMATION.

TSP INDICATES TRIPLE STUD POCKET BETWEEN WINDOW UNITS.

NOTE:
BCI 5000-18 JOISTS MAY BE USED IN LIEU OF TJI 210 JOISTS AT THE DEPTH AND SPACING INDICATED ON THE PLANS

TABLE R602.15
MINIMUM NUMBER OF FULL HEIGHT STUDS AT EACH END OF HEADERS IN EXTERIOR WALLS

HEADER SPAN (FEET)	MAXIMUM STUD SPACING (INCHES) (PER TABLE R602.3/5)	16	24
UP TO 3'		1	1
4'		2	1
8'		3	2
12'		5	3
16'		6	4

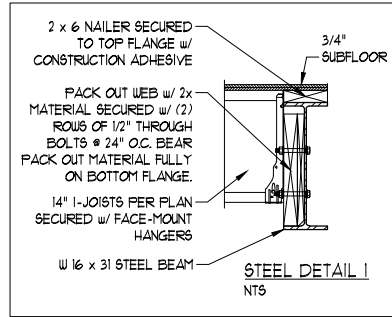
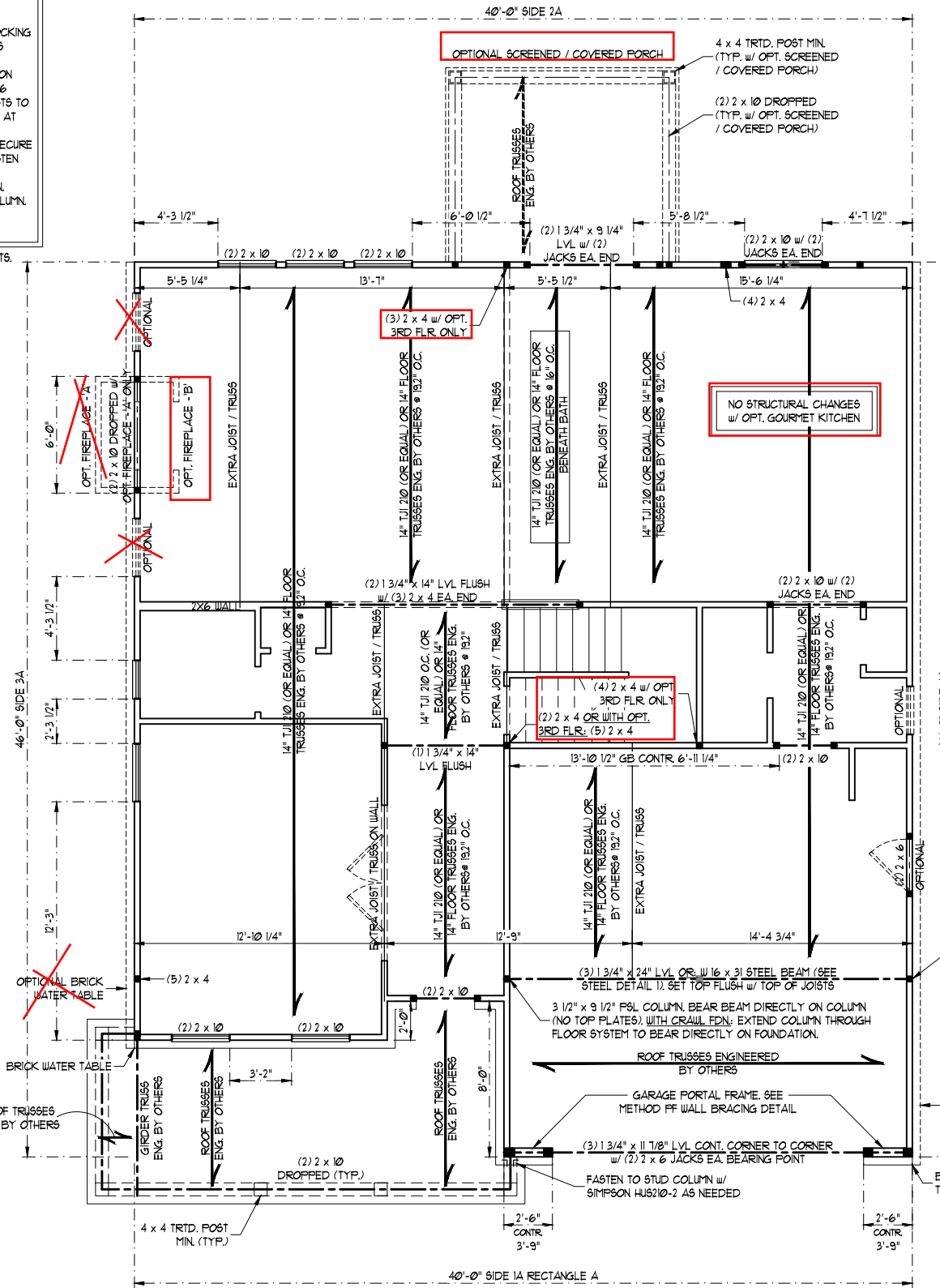

BRACED WALL DESIGN

RECTANGLE A		RECTANGLE B	
SIDE 1A (FRONT LOAD - ELEV. B)	SIDE 1B	SIDE 2A	SIDE 2B
METHOD: CS-WSP/GB/FF	METHOD: FF	METHOD: CS-WSP	METHOD: CS-WSP
TOTAL REQUIRED LENGTH: 12.75'	TOTAL REQUIRED LENGTH: 2.51'	TOTAL REQUIRED LENGTH: 12.75'	TOTAL REQUIRED LENGTH: 2.51'
TOTAL PROVIDED LENGTH: 11.60'	TOTAL PROVIDED LENGTH: 6.00'	TOTAL PROVIDED LENGTH: 20.61'	TOTAL PROVIDED LENGTH: 12.00'
SIDE 3A	SIDE 3B/4A COMBINED	SIDE 4B	SIDE 4B
METHOD: CS-WSP	METHOD: CS-WSP	METHOD: CS-WSP	METHOD: CS-WSP
TOTAL REQUIRED LENGTH: 11.21'	TOTAL REQUIRED LENGTH: 13.21'	TOTAL REQUIRED LENGTH: 13.21'	TOTAL REQUIRED LENGTH: 30.00'
TOTAL PROVIDED LENGTH: 34.83'	TOTAL PROVIDED LENGTH: 30.00'	TOTAL PROVIDED LENGTH: 12.10'	TOTAL PROVIDED LENGTH: 2.00'
SIDE 4A (SIDE LOAD)	SIDE 4B	SIDE 4B	SIDE 4B
METHOD: CS-WSP	METHOD: CS-WSP	METHOD: CS-WSP	METHOD: CS-WSP
TOTAL REQUIRED LENGTH: 11.21'	TOTAL REQUIRED LENGTH: 2.00'	TOTAL REQUIRED LENGTH: 19.33'	TOTAL REQUIRED LENGTH: 19.33'
TOTAL PROVIDED LENGTH: 21.50'	TOTAL PROVIDED LENGTH: 19.33'		

- BRACED WALL DESIGN NOTES:**
- BRACED WALL DESIGN PER SECTION R602.10 OF THE NRC 2018 EDITION.
 - CS-WSP REFERS TO "CONTINUOUS SHEATHING - WOOD STRUCTURAL PANELS" CONTRACTOR IS TO INSTALL 1/8" OSB ON ALL EXTERIOR WALLS ATTACHED w/ 8d NAILS SPACED 6" O.C. ALONG PANEL EDGES AND 12" O.C. IN THE FIELD.
 - "GB" REFERS TO "GYPSUM BOARD" CONTRACTOR IS TO INSTALL 1/2" (MIN.) GYPSUM WALL BOARD WHERE NOTED ON THE PLANS. FASTEN GB WITH 1 1/4" SCREWS OR 1 5/8" NAILS SPACED 1" O.C. ALONG PANEL EDGES AND IN THE FIELD INCLUDING TOP AND BOTTOM PLATES.
 - BRACED WALL DESIGN APPLIED IN WIND ZONES UP TO 130 MPH. FOR HIGH WIND ZONES, BRACE WALLS ARE TO BE CONSTRUCTED IN ACCORDANCE WITH CHAPTER 45 OF THE NRC 2018 EDITION.
 - SEE NOTES AND DETAIL SHEETS FOR ADDITIONAL BRACED WALL INFORMATION.

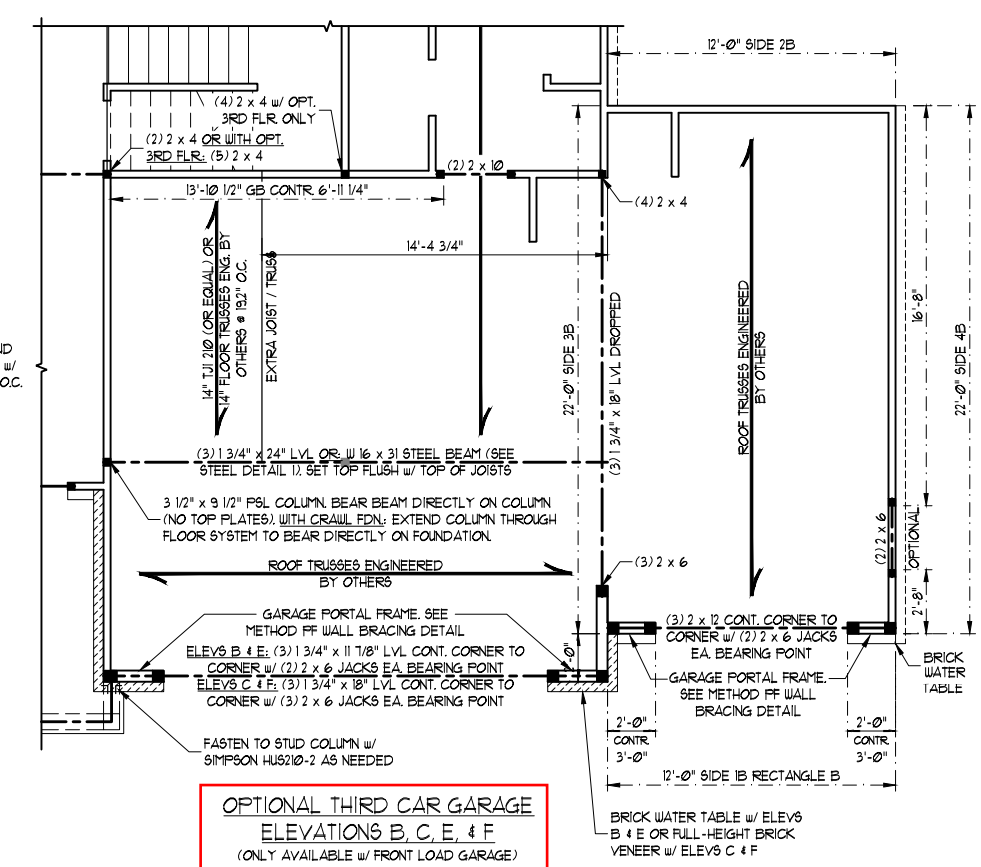

OPTIONAL THIRD CAR GARAGE
ELEVATIONS B, C, E, & F
(ONLY AVAILABLE w/ FRONT LOAD GARAGE)

PRINCE PLACE LOT 50

SCALE NOTE:
LARGE FORMAT PRINTS ARE TO SCALE AS NOTED.
11" x 17" PRINTS ARE ONE HALF THE NOTED SCALE



12/29/2022

J.S. THOMPSON ENGINEERING, INC
333 EAST SIX FORKS ROAD, SUITE 180, RALEIGH, NC 27609
PHONE: (919) 789-9919 FAX: (919) 789-9921
N.C. LICENSE NO.: C-1733

BRACED WALL DESIGN NOTES:

- BRACED WALL DESIGN PER SECTION R602.10 OF THE NRC 2018 EDITION.
- CS-USP REFERS TO "CONTINUOUS SHEATHING - WOOD STRUCTURAL PANELS" CONTRACTOR IS TO INSTALL 1/8" OSB ON ALL EXTERIOR WALLS ATTACHED w/ 8d NAILS SPACED 6" O.C. ALONG PANEL EDGES AND 12" O.C. IN THE FIELD.
- "GB" REFERS TO "GYPSUM BOARD" CONTRACTOR IS TO INSTALL 1/2" (MIN.) GYPSUM WALL BOARD WHERE NOTED ON THE PLANS. FASTEN GB WITH 1 1/4" SCREWS OR 1 5/8" NAILS SPACED 1" O.C. ALONG PANEL EDGES AND IN THE FIELD INCLUDING TOP AND BOTTOM FLATES.
- BRACED WALL DESIGN APPLIED IN WIND ZONES UP TO 130 MPH. FOR HIGH WIND ZONES, BRACE WALLS ARE TO BE CONSTRUCTED IN ACCORDANCE WITH CHAPTER 45 OF THE NRC 2018 EDITION.
- SEE NOTES AND DETAIL SHEETS FOR ADDITIONAL BRACED WALL INFORMATION.

NOTE:

- PER SECTION R602.10.3.2 OF THE 2018 NRC, THE AMOUNT OF BRACING ON THE SECOND FLOOR EXCEEDS THE AMOUNT REQUIRED FOR THE FIRST FLOOR AND NO BRACED WALL ANALYSIS IS REQUIRED.
- SHEATH ALL EXTERIOR WALLS WITH 1/8" OSB SHEATHING ATTACHED WITH 8d NAILS AT 6" O.C. ALONG PANEL EDGES AND 12" O.C. IN THE FIELD.

STRUCTURAL NOTES:

- ALL FRAMING LUMBER TO BE #2 SFF OR #2 SYP (INO).
- ALL LOAD BEARING HEADERS TO BE (2) 2 x 6 (INO).
- WINDOW AND DOOR HEADERS TO BE SUPPORTED w/ (1) JACK STUD AND (1) KING STUD EA. END (INO). SEE TABLE R602.15 FOR ADDITIONAL KING STUD REQUIREMENTS.
- SQUARES DENOTE POINT LOADS WHICH REQUIRE SOLID BLOCKING TO GIRDER OR FOUNDATION. SQUARES TO BE (2) STUDS (INO).
- REFER TO NOTES AND DETAIL SHEETS FOR ADDITIONAL STRUCTURAL INFORMATION.

TABLE R602.15
MINIMUM NUMBER OF FULL HEIGHT STUDS AT EACH END OF HEADERS IN EXTERIOR WALLS

HEADER SPAN (FEET)	MAXIMUM STUD SPACING (INCHES) (PER TABLE R602.15)	
	16	24
UP TO 3'	1	1
4'	2	1
8'	3	2
12'	5	3
16'	6	4

DATE: DECEMBER 29, 2022
SCALE: 1/4" = 1'-0"
DRAWN BY: MAIN STREET DESIGNS
ENGINEERED BY: ZHH

S-4e
ATTIC FLOOR
FRAMING PLAN

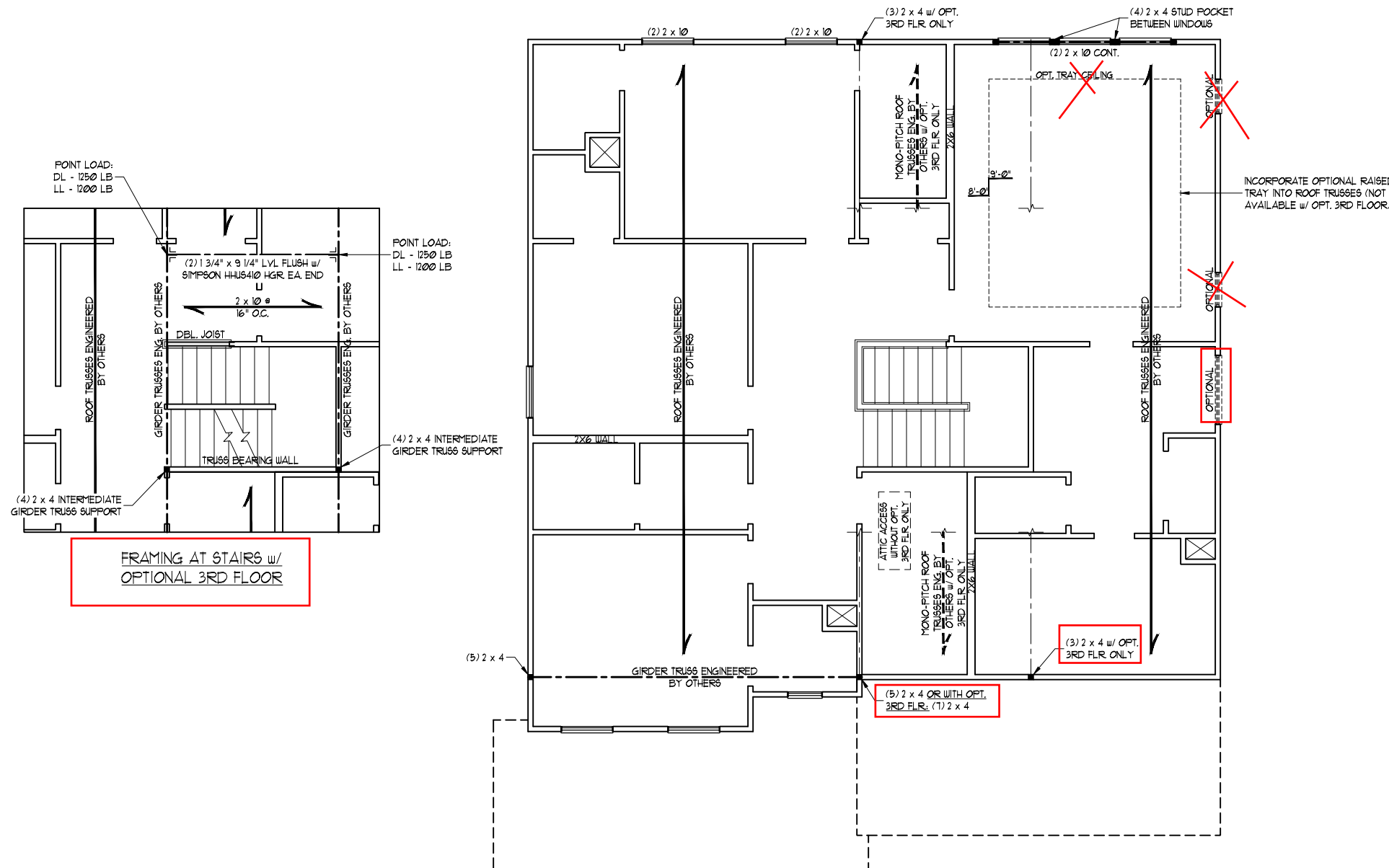

FRAMING AT STAIRS w/
OPTIONAL 3RD FLOOR

ELEVATION E

PRINCE PLACE LOT 50

SCALE NOTE:
LARGE FORMAT PRINTS ARE TO SCALE AS NOTED.
11" x 17" PRINTS ARE ONE HALF THE NOTED SCALE



12/29/2022

J.S. THOMPSON ENGINEERING, INC
333 EAST SIX FORKS ROAD, SUITE 180 RALEIGH, NC 27609
PHONE: (919) 789-9919 FAX: (919) 789-9921
N.C. LICENSE NO.: C-1733

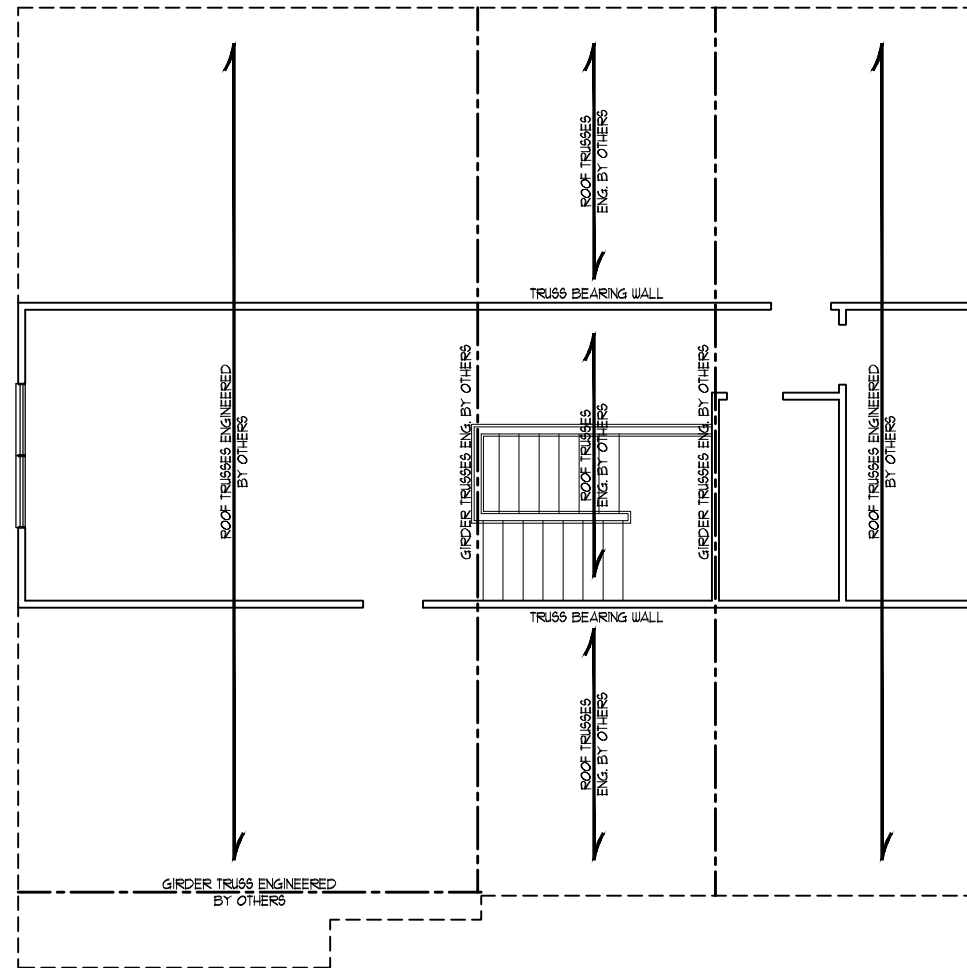

OPTIONAL 3RD FLOOR
(SHOWN WITH ELEVATION A - ALL OTHER ELEVATIONS SIMILAR)

BRACED WALL DESIGN NOTES:

- BRACED WALL DESIGN PER SECTION R602.10 OF THE NRC 2018 EDITION.
- CS-USP REFERS TO "CONTINUOUS SHEATHING - WOOD STRUCTURAL PANELS" CONTRACTOR IS TO INSTALL 1/8" OSB ON ALL EXTERIOR WALLS ATTACHED w/ 8d NAILS SPACED 6" O.C. ALONG PANEL EDGES AND 12" O.C. IN THE FIELD.
- GB REFERS TO "GYPSUM BOARD" CONTRACTOR IS TO INSTALL 1/2" (MIN.) GYPSUM WALL BOARD WHERE NOTED ON THE PLANS. FASTEN GB WITH 1 1/4" SCREWS OR 1 5/8" NAILS SPACED 1" O.C. ALONG PANEL EDGES AND IN THE FIELD INCLUDING TOP AND BOTTOM FLATES.
- BRACED WALL DESIGN APPLIED IN WIND ZONES UP TO 130 MPH. FOR HIGH WIND ZONES, BRACE WALLS ARE TO BE CONSTRUCTED IN ACCORDANCE WITH CHAPTER 45 OF THE NRC 2018 EDITION.
- SEE NOTES AND DETAIL SHEETS FOR ADDITIONAL BRACED WALL INFORMATION.

NOTE:

- PER TABLE R602.10.3 OF THE 2018 NRC, THE 3RD FLOOR IS CONTAINED WHOLLY WITHIN THE ROOF SYSTEM AND WALL BRACING ANALYSIS IS NOT REQUIRED ON THE 3RD FLOOR. IN ADDITION, THE 3RD FLOOR NEED NOT BE CONSIDERED A STORY IN THE FIRST OR SECOND FLOOR WALL BRACING ANALYSIS.
- SHEATH ALL EXTERIOR WALLS WITH 1/8" OSB SHEATHING ATTACHED WITH 8d NAILS AT 6" O.C. ALONG PANEL EDGES AND 12" O.C. IN THE FIELD.

STRUCTURAL NOTES:

- ALL FRAMING LUMBER TO BE #2 SFF OR #2 SYP (UNO).
- ALL LOAD BEARING HEADERS TO BE (2) 2 x 6 (UNO).
- WINDOW AND DOOR HEADERS TO BE SUPPORTED w/ (1) JACK STUD AND (1) KING STUD EA. END (UNO). SEE TABLE R602.15 FOR ADDITIONAL KING STUD REQUIREMENTS.
- SQUARES DENOTE POINT LOADS WHICH REQUIRE SOLID BLOCKING TO GIRDER OR FOUNDATION. SQUARES TO BE (2) STUDS (UNO).
- REFER TO NOTES AND DETAIL SHEETS FOR ADDITIONAL STRUCTURAL INFORMATION.

TABLE R602.15
MINIMUM NUMBER OF FULL HEIGHT STUDS AT EACH END OF HEADERS IN EXTERIOR WALLS

HEADER SPAN (FEET)	MAXIMUM STUD SPACING (INCHES) (PER TABLE R602.3/5)	
	16"	24"
UP TO 3'	1	1
4'	2	1
8'	3	2
12'	5	3
16'	6	4

DATE: DECEMBER 29, 2022
SCALE: 1/4" = 1'-0"
DRAWN BY: MAIN STREET DESIGNS
ENGINEERED BY: ZHH

HICKORY
DAVIDSON HOMES

S-5
CEILING
FRAMING PLAN

PRINCE PLACE LOT 50

SCALE NOTE:
LARGE FORMAT PRINTS ARE TO SCALE AS NOTED.
11" x 17" PRINTS ARE ONE HALF THE NOTED SCALE



12/29/2022

J.S. THOMPSON ENGINEERING, INC
333 EAST SIX FORKS ROAD, SUITE 180 RALEIGH, NC 27609
PHONE: (919) 789-9919 FAX: (919) 789-9921
N.C. LICENSE NO.: C-1733

STRUCTURAL NOTES:

- ALL FRAMING LUMBER TO BE #2 SPF OR #1 SYP (UNO).
- STICK FRAME OVER-FRAMED ROOF SECTIONS W/ 2 x 8 RIDGES, 2 x 6 RAFTERS @ 16" O.C. AND FLAT 2 x 10 VALLEYS OR USE VALLEY TRUSSES.
- FASTEN FLAT VALLEYS TO RAFTERS OR TRUSSES WITH SIMPSON H25A HURRICANE TIES @ 32" O.C. MAX. PASS HURRICANE TIES THROUGH NOTCH IN ROOF SHEATHING. EACH RAFTER IS TO BE FASTENED TO THE FLAT VALLEY WITH A MIN. OF (6) 12d TOE NAILS.
- REFER TO SECTION R202.11 OF THE 2018 NCRS FOR REQUIRED UPLIFT RESISTANCE AT RAFTERS AND TRUSSES.
- REFER TO NOTES AND DETAIL SHEETS FOR ADDITIONAL STRUCTURAL INFORMATION.

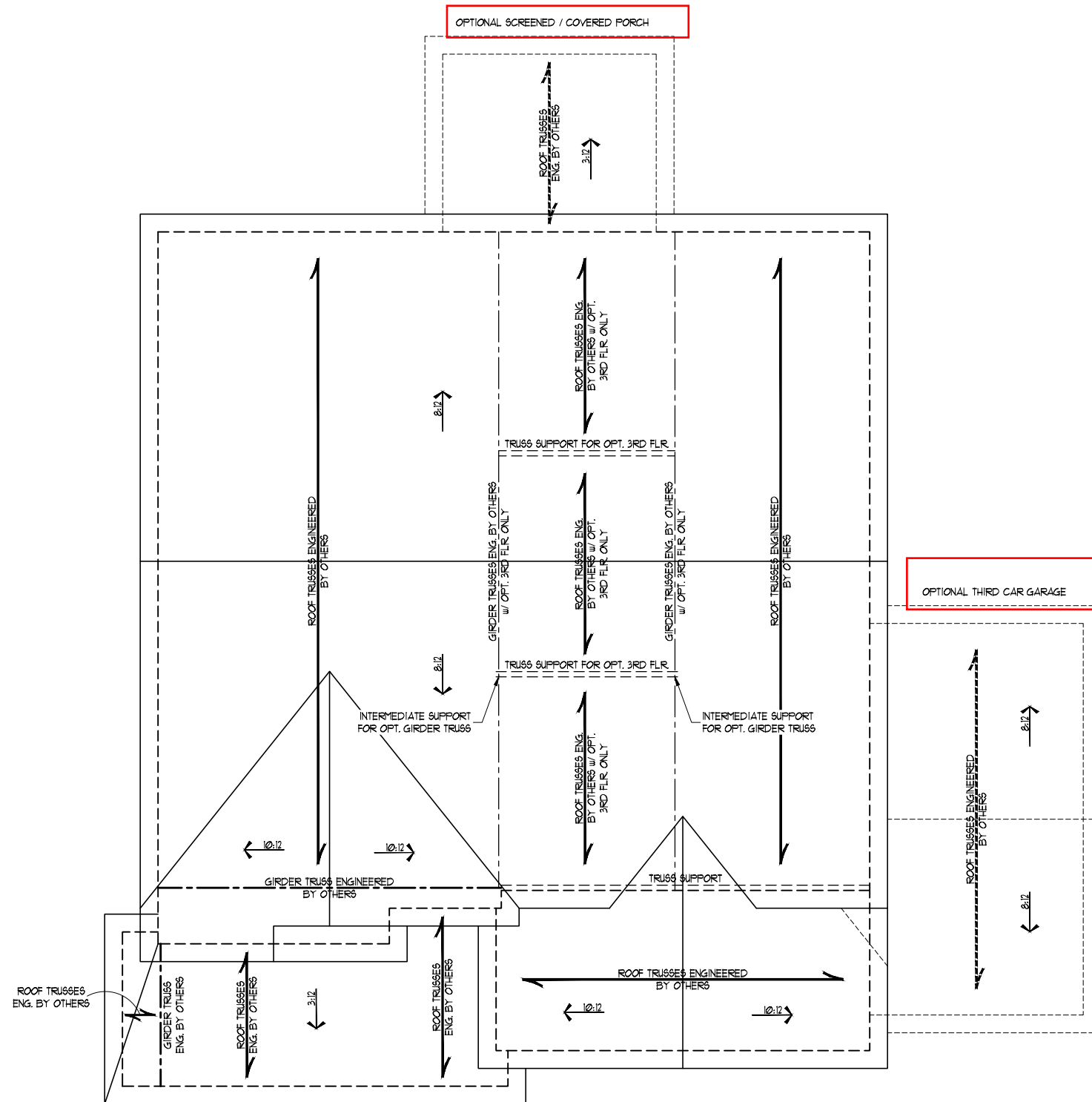

ELEVATION E

HICKORY DAVIDSON HOMES

DATE: DECEMBER 29, 2022
SCALE: 1/4" = 1'-0"
DRAWN BY: MAIN STREET DESIGNS
ENGINEERED BY: ZHH

S-6
ROOF FRAMING PLAN

GENERAL WALL BRACING NOTES:

1. WALL BRACING DESIGNED IN ACCORDANCE WITH CHAPTER 6 OF THE 2018 NC RESIDENTIAL BUILDING CODE (NRC). TABLES AND FIGURES REFERENCED ARE FROM THE 2018 NRC.
2. SEE THIS SHEET FOR GENERAL DETAILS. REFER TO THE 2018 NRC FOR ADDITIONAL INFORMATION AS NEEDED.
3. BRACED EXTERIOR WALLS SUPPORTING ROOF TRUSSES AND RAFTERS, INCLUDING STORIES BELOW THE TOP FLOOR, HAVE BEEN DESIGNED PER R602.3.5 (3). WALL SHEATHING AND FASTENERS HAVE BEEN DESIGNED TO RESIST COMBINED UPLIFT AND SHEAR FORCES IN ACCORDANCE WITH ACCEPTED ENGINEERING PRACTICE.
4. SEE STRUCTURAL SHEETS FOR BRACED WALL LOCATIONS, DIMENSIONS, HOLD DOWN TYPE AND LOCATIONS, BRACED WALL LINE KEY WITH WALL DESIGN SUMMARY OF REQUIRED/PROVIDED TOTALS FOR EACH WALL LINE AND ANY SPECIAL NOTES OR REQUIREMENTS.
5. ALL EXTERIOR WALLS ARE TO BE SHEATHED WITH C5-WSP IN ACCORDANCE WITH SECTION R602.10.3 UNLESS NOTED OTHERWISE.
6. ALL EXTERIOR AND INTERIOR WALLS TO HAVE 1/2" GYPSUM INSTALLED. WHEN NOT USING METHOD "GB", GYPSUM TO BE FASTENED PER TABLE R102.3.5. METHOD GB TO BE FASTENED PER TABLE R602.10.
7. C5-WSP REFERS TO THE "CONTINUOUS SHEATHING - WOOD STRUCTURAL PANELS" WALL BRACING METHOD. 7/16" OSB SHEATHING IS TO BE INSTALLED ON ALL EXTERIOR WALLS ATTACHED w/ 6d COMMON NAILS OR 8d (2 1/2" LONG x 0.131" DIAMETER) NAILS SPACED 6" O.C. ALONG PANEL EDGES AND 12" O.C. IN THE FIELD (UNO).
8. GB REFERS TO THE "GYPSUM BOARD" WALL BRACING METHOD. 1/2" (MIN) GYPSUM WALL BOARD IS TO BE INSTALLED ON BOTH SIDES OF THE BRACED WALL FASTENED WITH 1 1/4" SCREWS OR 1 5/8" NAILS SPACED 1" O.C. ALONG PANEL EDGES INCLUDING TOP AND BOTTOM PLATES AND INTERMEDIATE SUPPORTS (UNO). VERIFY ALL FASTENER OPTIONS FOR 1/2" AND 5/8" GYPSUM PRIOR TO CONSTRUCTION. FOR INTERIOR FASTENER OPTIONS SEE TABLE R102.3.5. FOR EXTERIOR FASTENER OPTIONS SEE TABLE R602.3(1). EXTERIOR GB TO BE INSTALLED VERTICALLY.
9. REQUIRED BRACED WALL LENGTH FOR EACH SIDE OF THE CIRCUMSCRIBED RECTANGLE ARE INTERPOLATED PER TABLE R602.10.3. METHOD C5-WSP CONTRIBUTES ITS ACTUAL LENGTH, METHOD GB CONTRIBUTES 5 ITS ACTUAL LENGTH, AND METHOD PF CONTRIBUTES 15 TIMES ITS ACTUAL LENGTH.

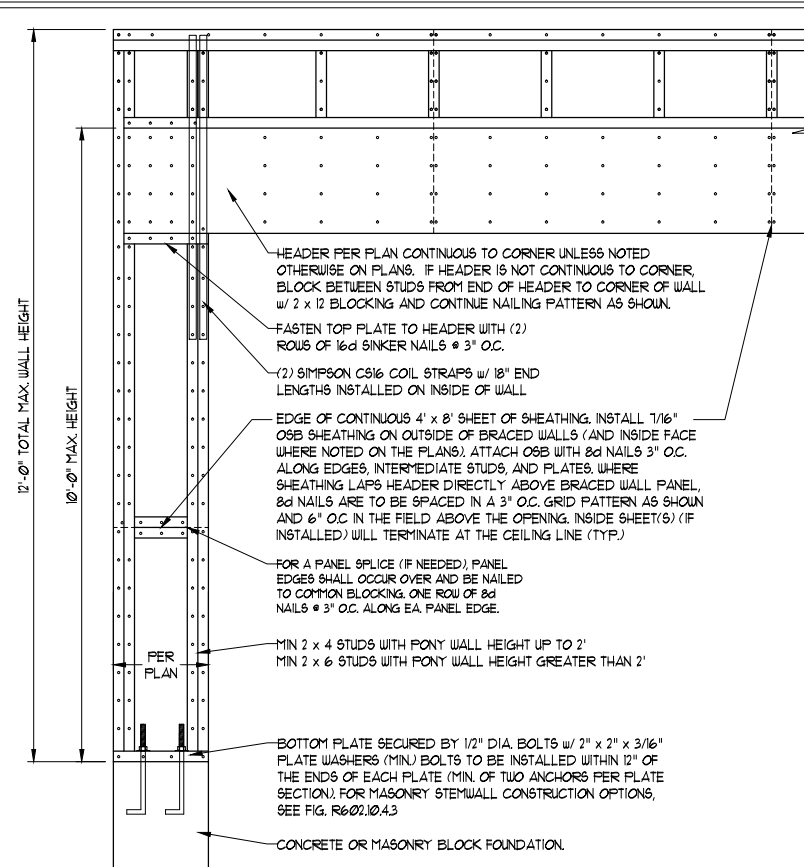

OVER CONCRETE OR MASONRY BLOCK FOUNDATION

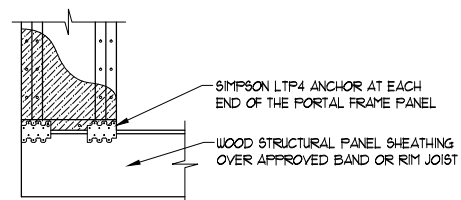

OVER RAISED WOOD FLOOR - FRAMING ANCHOR OPTION
 * APPLICABLE w/ GREATER THAN 12" KNEE WALL HEIGHTS
 IN CRAWL SPACE AND ABOVE FRAMED BASEMENT WALLS *

METHOD PF-PORTAL FRAME DETAIL ①

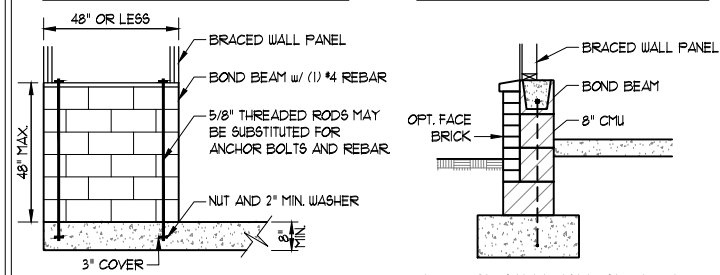
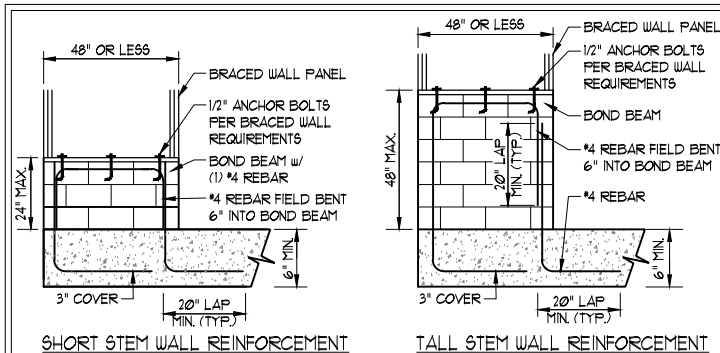

RODS MAY BE INSTALLED USING AN ADHESIVE ANCHORING SYSTEM WITH A MINIMUM TENSILE CAPACITY OF 3150 LBS AND INSTALLED IN ACCORDANCE WITH MANUFACTURER'S SPECS.
 OPTIONAL STEM WALL REINFORCEMENT

NOTE: GROUT BOND BEAMS AND ALL CELLS WHICH CONTAIN REBAR, THREADED RODS AND ANCHOR BOLTS
 MASONRY STEM WALLS SUPPORTING BRACED WALL PANELS ②
 PER FIGURE R602.10.4.3

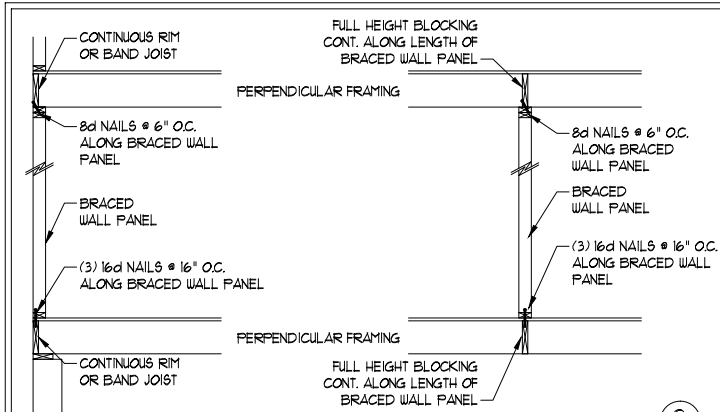

BRACED WALL PANEL CONNECTION WHEN ③
 PERPENDICULAR TO FLOOR/CEILING FRAMING
 PER FIGURE R602.10.4.4(1)

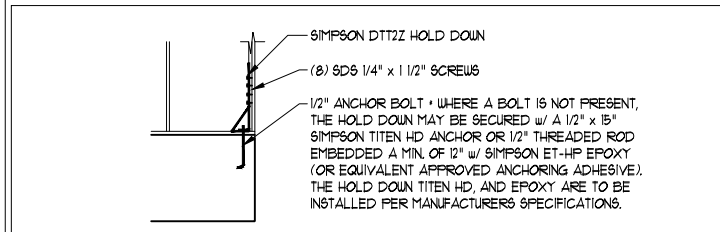

HOLD DOWN DETAIL FOR MASONRY FOUNDATION OR MONOLITHIC SLAB ④
 * APPLICABLE ONLY WHERE SPECIFIED ON PLAN *

TYPICAL EXTERIOR CORNER FRAMING FOR CONTINUOUS SHEATHING ⑤

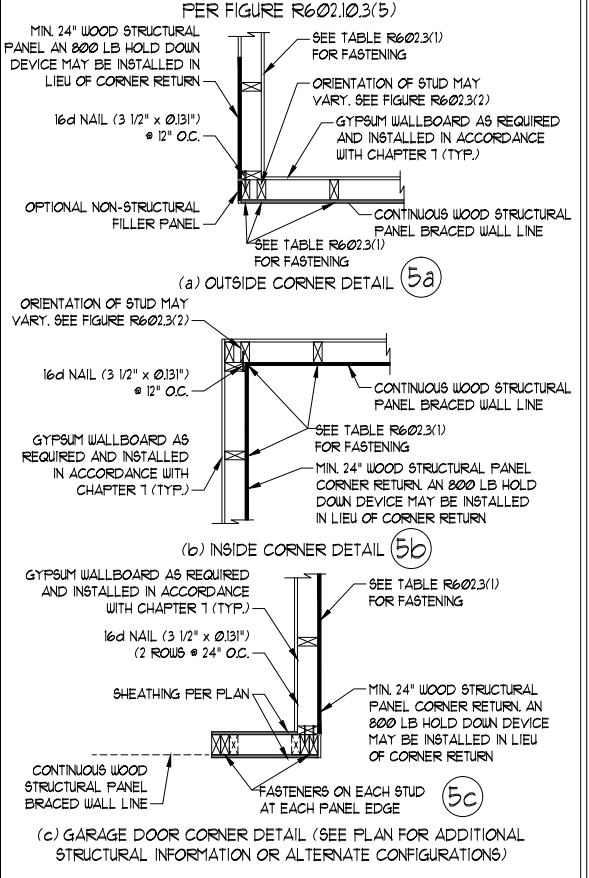

BRACED WALL PANEL CONNECTION WHEN PARALLEL TO FLOOR/CEILING FRAMING ⑥

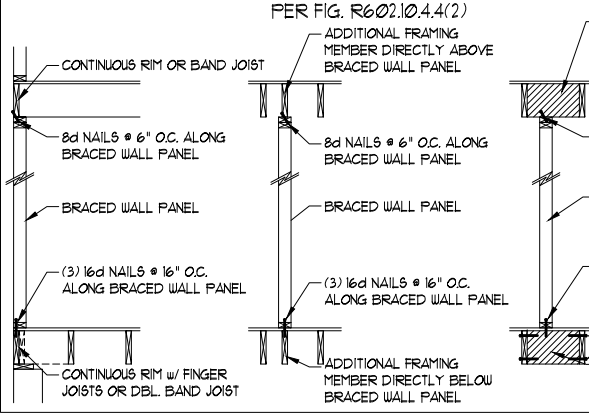

PER FIG. R602.10.4.4(2)

SCALE NOTE:
 LARGE FORMAT PRINTS ARE TO SCALE AS NOTED.
 11" x 17" PRINTS ARE ONE HALF THE NOTED SCALE

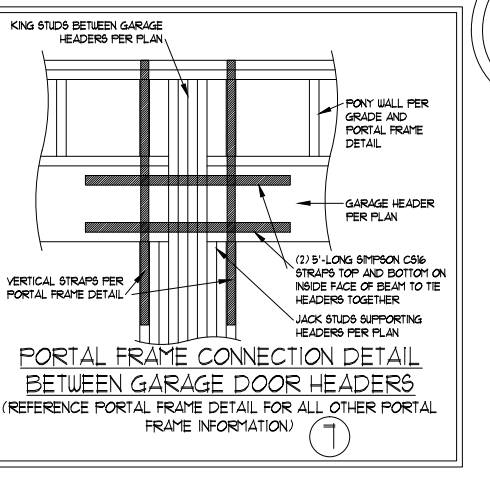

BRACED WALL PANEL CONNECTION TO PERPENDICULAR RAFTERS ⑧

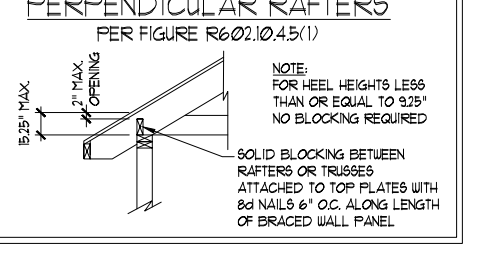

BRACED WALL PANEL CONNECTION TO PERPENDICULAR ROOF TRUSSES ⑨

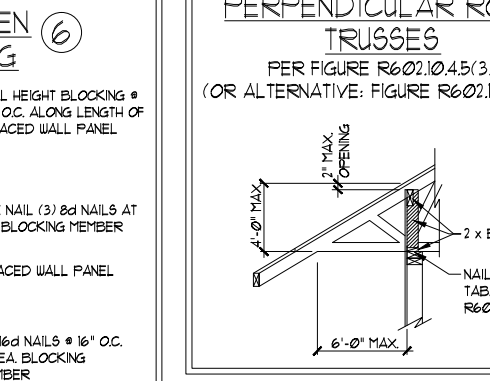

PER FIGURE R602.10.4.5(3)
 (OR ALTERNATIVE: FIGURE R602.10.4.5(2))



J.S. THOMPSON ENGINEERING, INC
 333 EAST SIX FORKS ROAD, SUITE 180 RALEIGH, NC 27609
 PHONE: (919) 789-9919 FAX: (919) 789-9921
 N.C. LICENSE NO.: C-1733

HICKORY DAVIDSON HOMES

DATE: DECEMBER 29, 2022
 SCALE: 1/4" = 1'-0"
 DRAWN BY: MAIN STREET DESIGNS
 ENGINEERED BY: ZHH

D4
 WALL BRACING NOTES AND DETAILS

12/29/2022

This sealed page is to be used in conjunction with a full plan set engineered by J.S. Thompson Engineering, Inc. only. Use of this individual sealed page within architectural pages or shop drawings by others is a punishable offense under N.C. Statute §89C-23

GENERAL NOTES

- ENGINEER'S SEAL APPLIES ONLY TO STRUCTURAL COMPONENTS INCLUDING ROOF RAFTERS, HIPS, VALLEYS, RIDGES, FLOORS, WALLS, BEAMS, HEADERS, COLUMNS, CANTILEVERS, OFFSET LOAD BEARING WALLS, PIERS, GIRDER SYSTEM AND FOOTING. ENGINEER'S SEAL DOES NOT CERTIFY DIMENSIONAL ACCURACY OF ARCHITECTURAL LAYOUT INCLUDING ROOF. ENGINEER'S SEAL DOES NOT APPLY TO I-JOIST OR FLOOR/ROOF TRUSS LAYOUT DESIGN AND ACCURACY.
- ALL CONSTRUCTION SHALL CONFORM TO THE LATEST REQUIREMENTS OF THE NORTH CAROLINA RESIDENTIAL CODE (NRC), 2018 EDITION, PLUS ALL LOCAL CODES AND REGULATIONS. THE STRUCTURAL ENGINEER IS NOT RESPONSIBLE FOR, AND WILL NOT HAVE CONTROL OF, CONSTRUCTION MEANS, METHODS, TECHNIQUES, SEQUENCES OR PROCEDURES, OR SAFETY PRECAUTIONS AND PROGRAMS IN CONNECTION WITH THE CONSTRUCTION WORK. NOR WILL THE ENGINEER BE RESPONSIBLE FOR THE CONTRACTOR'S FAILURE TO CARRY OUT THE CONSTRUCTION WORK IN ACCORDANCE WITH THE CONTRACT DOCUMENTS.
- STRUCTURAL DESIGN BASED ON THE PROVISIONS OF THE NRC, 2018 EDITION (R301.4 - R301.7)

DESIGN CRITERIA:	LIVE LOAD (PSF)	DEAD LOAD (PSF)	DEFLECTION (IN)
ATTIC WITH LIMITED STORAGE	20	10	L/240 (L/360 w/ BRITTLE FINISHES)
ATTIC WITHOUT STORAGE	10	10	L/360
DECKS	40	10	L/360
EXTERIOR BALCONIES	40	10	L/360
FIRE ESCAPES	40	10	L/360
HANDRAILS/GUARDRAILS	200 LB OR 50 (PLF)	10	L/360
PASSENGER VEHICLE GARAGE	50	10	L/360
ROOMS OTHER THAN SLEEPING ROOM	40	10	L/360
SLEEPING ROOMS	30	10	L/360
STAIRS	40	10	L/360
WIND LOAD	(BASED ON TABLE R302(4) WIND ZONE AND EXPOSURE)		
GROUND SNOW LOAD: P _g	20 (PSF)		

- I-JOIST SYSTEMS DESIGNED WITH 12 PSF DEAD LOAD AND DEFLECTION (IN) OF L/480
- FLOOR TRUSS SYSTEMS DESIGNED WITH 15 PSF DEAD LOAD

- FOR 15 AND 120 MPH WIND ZONES, FOUNDATION ANCHORAGE IS TO COMPLY WITH SECTION R403.1.6 OF THE NRC, 2018 EDITION. FOR 130 MPH, 140 MPH, AND 150 MPH WIND ZONES, FOUNDATION ANCHORAGE IS TO COMPLY WITH SECTION 4504 OF THE NRC, 2018 EDITION.
- ENERGY EFFICIENCY COMPLIANCE AND INSULATION VALUES OF THE BUILDING TO BE IN ACCORDANCE WITH CHAPTER 11 OF THE NRC, 2018 EDITION.

FOOTING AND FOUNDATION NOTES

- FOUNDATION DESIGN BASED ON A MINIMUM ALLOWABLE BEARING CAPACITY OF 2000 PSF. CONTACT GEOTECHNICAL ENGINEER IF BEARING CAPACITY IS NOT ACHIEVED.
- FOR ALL CONCRETE SLABS AND FOOTINGS, THE AREA WITHIN THE PERIMETER OF THE BUILDING ENVELOPE SHALL HAVE ALL VEGETATION, TOP SOIL AND FOREIGN MATERIAL REMOVED. FILL MATERIAL SHALL BE FREE OF VEGETATION AND FOREIGN MATERIAL. THE FILL SHALL BE COMPACTED TO ASSURE UNIFORM SUPPORT OF THE SLAB, AND EXCEPT WHERE APPROVED, THE FILL DEPTHS SHALL NOT EXCEED 24" FOR CLEAN SAND OR GRAVEL. A 4" THICK BASED COURSE CONSISTING OF CLEAN GRADED SAND OR GRAVEL SHALL BE PLACED. A BASE COURSE IS NOT REQUIRED WHERE A CONCRETE SLAB IS INSTALLED ON WELL-DRAINED OR SAND-GRAVEL MIXTURE SOILS CLASSIFIED AS GROUP 1, ACCORDING TO THE UNITED SOIL CLASSIFICATION SYSTEM IN ACCORDANCE WITH TABLE R405.1 OF THE NRC, 2018 EDITION.
- PROPERLY DEWATER EXCAVATION PRIOR TO POURING CONCRETE WHEN BOTTOM OF CONCRETE SLAB IS AT OR BELOW WATER TABLE. IF APPLICABLE, 3/4" - 1" DEEP CONTROL JOINTS ARE TO BE SAUED WITHIN 4 TO 12 HOURS OF CONCRETE FINISHING AND WALL LOCATIONS HAVE BEEN MARKED. ADJUST WHERE NECESSARY.
- CONCRETE SHALL CONFORM TO SECTION R402.2 OF THE NRC, 2018 EDITION. CONCRETE REINFORCING STEEL TO BE ASTM A615 GRADE 60. WELDED WIRE FABRIC TO BE ASTM A185. MAINTAIN A MINIMUM CONCRETE COVER AROUND REINFORCING STEEL OF 3" IN FOOTINGS AND 1 1/2" IN SLABS. FOR POURED CONCRETE WALLS, CONCRETE COVER FOR REINFORCING STEEL MEASURED FROM THE INSIDE FACE OF THE WALL SHALL NOT BE LESS THAN 3/4". CONCRETE COVER FOR REINFORCING STEEL MEASURED FROM THE OUTSIDE FACE OF THE WALL SHALL NOT BE LESS THAN 1 1/2" FOR #5 BARS OR SMALLER, AND NOT LESS THAN 2" FOR #6 BARS OR LARGER.
- MASONRY UNITS TO CONFORM TO ACE 530/ASCE 5/TMS 402. MORTAR SHALL CONFORM TO ASTM C270.
- THE UNSUPPORTED HEIGHT OF MASONRY PIERS SHALL NOT EXCEED FOUR TIMES THEIR LEAST DIMENSION FOR UNFILLED HOLLOW CONCRETE MASONRY UNITS AND TEN TIMES THEIR LEAST DIMENSION FOR SOLID OR SOLID FILLED PIERS. PERS MAY BE FILLED SOLID WITH CONCRETE OR TYPE M OR S MORTAR. PIERS AND WALLS SHALL BE CAPPED WITH 8" OF SOLID MASONRY.
- THE CENTER OF EACH OF THE PIERS SHALL BEAR IN THE MIDDLE THIRD OF ITS RESPECTIVE FOOTING. EACH GIRDER SHALL BEAR IN THE MIDDLE THIRD OF THE PIERS.
- ALL CONCRETE AND MASONRY FOUNDATION WALLS ARE TO BE CONSTRUCTED IN ACCORDANCE WITH THE PROVISIONS OF SECTION R404 OF THE NRC, 2018 EDITION OR IN ACCORDANCE WITH ACI 318, ACI 332, NCMA TR68-A OR ACE 530/ASCE 5/TMS 402. MASONRY FOUNDATION WALLS ARE TO BE REINFORCED PER TABLE R404.1(K1), R404.1(K2), R404.1(K3), OR R404.1(K4) OF THE NRC, 2018 EDITION. CONCRETE FOUNDATION WALLS ARE TO BE REINFORCED PER TABLE R404.1(K5) OF THE NRC, 2018 EDITION. STEP CONCRETE FOUNDATION WALLS TO 2 x 6 FRAMED WALLS AT 16" O.C. WHERE GRADE PERMITS (UNO).

FRAMING NOTES

- ALL FRAMING LUMBER SHALL BE #2 SPF (F_b = 875 PSF, F_v = 375 PSF, E = 1600000 PSF) OR #2 SYP (F_b = 975 PSF, F_v = 175 PSF, E = 1600000 PSF) MINIMUM UNLESS NOTED OTHERWISE (UNO). ALL TREATED LUMBER SHALL BE #2 SYP MINIMUM UNLESS NOTED OTHERWISE (UNO).
- LAMINATED VENEER LUMBER (LVL) SHALL HAVE THE FOLLOWING MINIMUM PROPERTIES: F_b = 2600 PSF, F_v = 285 PSF, E = 1900000 PSF. LAMINATED STRAND LUMBER (LSL) SHALL HAVE THE FOLLOWING MINIMUM PROPERTIES: F_b = 2325 PSF, F_v = 310 PSF, E = 1550000 PSF. PARALLEL STRAND LUMBER (PSL) UP TO 1" DEPTH SHALL HAVE THE FOLLOWING MINIMUM PROPERTIES: F_c = 2500 PSF, E = 1800000 PSF. PARALLEL STRAND LUMBER (PSL) MORE THAN 1" DEPTH SHALL HAVE THE FOLLOWING MINIMUM PROPERTIES: F_c = 2900 PSF, E = 2000000 PSF. INSTALL ALL CONNECTIONS PER MANUFACTURER'S SPECIFICATIONS.
- STRUCTURAL STEEL SHALL CONFORM TO THE FOLLOWING ASTM SPECIFICATIONS

A. W AND WT SHAPES:	ASTM A992
B. CHANNELS AND ANGLES:	ASTM A36
C. PLATES AND BARS:	ASTM A36
D. HOLLOW STRUCTURAL SECTIONS:	ASTM A500 GRADE B
E. STEEL PIPE:	ASTM A53, GRADE B, TYPE E OR S
- STEEL BEAMS SHALL BE SUPPORTED AT EACH END WITH A MINIMUM BEARING LENGTH OF 3 1/2" AND FULL FLANGE WIDTH (UNO). PROVIDE SOLID BEARING FROM BEAM SUPPORT TO FOUNDATION. BEAMS SHALL BE ATTACHED AT THE BOTTOM FLANGE TO EACH SUPPORT AS FOLLOWS (UNO):

A. WOOD FRAMING	(2) 1/2" DIA. x 4" LONG LAG SCREWS
B. CONCRETE	(2) 1/2" DIA. x 4" WEDGE ANCHORS
C. MASONRY (FULLY GROUTED)	(2) 1/2" DIA. x 4" LONG SIMPSON TITEN HD ANCHORS

LATERAL SUPPORT IS CONSIDERED ADEQUATE PROVIDING THE JOISTS ARE TOE NAILED TO THE 2x NAILER ON TOP OF THE STEEL BEAM, AND THE 2x NAILER IS SECURED TO THE TOP OF THE STEEL BEAM w/ (2) ROWS OF SELF TAPPING SCREWS @ 16" O.C. OR (2) ROWS OF 1/2" DIAMETER BOLTS @ 16" O.C. IF 1/2" BOLTS ARE USED TO FASTEN THE NAILER, THE STEEL BEAM SHALL BE FABRICATED w/ (2) ROWS OF 9/16" DIAMETER HOLES @ 16" O.C.
- SQUARES DENOTE POINT LOADS WHICH REQUIRE SOLID BLOCKING TO GIRDER OR FOUNDATION. SHADED SQUARES DENOTE POINT LOADS FROM ABOVE WHICH REQUIRE SOLID BLOCKING TO SUPPORTING MEMBER BELOW.
- ALL LOAD BEARING HEADERS TO CONFORM TO TABLE R602.1(1) AND R602.1(2) OF THE NRC, 2018 EDITION OR BE (2) 2 x 6 WITH (1) JACK AND (1) KING STUD EACH END (UNO), WHICHEVER IS GREATER ALL HEADERS TO BE SECURED TO EACH JACK STUD WITH (4) 8d NAILS. ALL BEAMS TO BE SUPPORTED WITH (2) STUDS AT EACH BEARING POINT (UNO). INSTALL KING STUDS PER SECTION R602.1.5 OF THE NORTH CAROLINA RESIDENTIAL CODE, 2018 EDITION.
- ALL BEAMS, HEADERS, OR GIRDER TRUSSES PARALLEL TO WALL ARE TO BEAR FULLY ON (1) JACK OR (2) STUDS MINIMUM OR THE NUMBER OF JACKS OR STUDS NOTED. ALL BEAMS OR GIRDER TRUSSES PERPENDICULAR TO WALL AND SUPPORTED BY (3) STUDS OR LESS ARE TO HAVE 1 1/2" MINIMUM BEARING (UNO). ALL BEAMS OR GIRDER TRUSSES PERPENDICULAR TO WALL AND SUPPORTED BY MORE THAN (3) STUDS OR OTHER NOTED COLUMN ARE TO BEAR FULLY ON SUPPORT COLUMN FOR ENTIRE WALL DEPTH (UNO). BEAM ENDS THAT BUTT INTO ONE ANOTHER ARE TO EACH BEAR EQUAL LENGTHS (UNO).
- FLITCH BEAMS SHALL BE BOLTED TOGETHER USING 1/2" DIAMETER BOLTS (ASTM A307) WITH WASHERS PLACED AT THREADED END OF BOLT. BOLTS SHALL BE SPACED AT 24" CENTERS (MAXIMUM), AND STAGGERED AT TOP AND BOTTOM OF BEAM (2" EDGE DISTANCE), WITH (2) BOLTS LOCATED AT 6" FROM EACH END (UNO).
- ALL I-JOIST OR TRUSS LAYOUTS ARE TO BE IN COMPLIANCE WITH THE OVERALL DESIGN SPECIFIED ON THE PLANS. ALL DEVIATIONS ARE TO BE BROUGHT TO THE ATTENTION OF THE ENGINEER OF RECORD PRIOR TO INSTALLATION.
- BRACED WALL PANELS SHALL BE CONSTRUCTED ACCORDING TO THE NORTH CAROLINA RESIDENTIAL CODE 2018 EDITION WALL BRACING CRITERIA. THE AMOUNT, LENGTH, AND LOCATION OF BRACING SHALL COMPLY WITH ALL APPLICABLE TABLES IN SECTION R602.10.
- PROVIDE DOUBLE JOIST UNDER ALL WALLS PARALLEL TO FLOOR JOISTS. PROVIDE SUPPORT UNDER ALL WALLS PARALLEL TO FLOOR TRUSSES OR I-JOISTS PER MANUFACTURER'S SPECIFICATIONS. INSTALL BLOCKING BETWEEN JOISTS OR TRUSSES FOR POINT LOAD SUPPORT FOR ALL POINT LOADS ALONG OFFSET LOAD LINES.
- FOR ALL HEADERS SUPPORTING BRICK VENEER THAT ARE LESS THAN 8'-0" IN LENGTH, REST A 6" x 4" x 5/16" STEEL ANGLE WITH 6" MINIMUM EMBEDMENT AT SIDES FOR BRICK SUPPORT (UNO). FOR ALL HEADERS 8'-0" AND GREATER IN LENGTH, BOLT A 6" x 4" x 5/16" STEEL ANGLE TO HEADER WITH 1/2" LAG SCREWS AT 12" O.C. STAGGERED FOR BRICK SUPPORT. FOR ALL BRICK SUPPORT AT ROOF LINES, BOLT A 6" x 4" x 5/16" STEEL ANGLE TO (2) 2 x 10 BLOCKING INSTALLED w/ (4) 12d NAILS EA. PLY BETWEEN WALL STUDS WITH (2) ROWS OF 1/2" LAG SCREWS AT 12" O.C. STAGGERED AND IN ACCORDANCE WITH SECTION R703.2.1 OF THE NRC, 2018 EDITION.
- FOR STICK FRAMED ROOFS: CIRCLES DENOTE (3) 2 x 4 POSTS FOR ROOF MEMBER SUPPORT. HIP SPLICES ARE TO BE SPACED A MINIMUM OF 8'-0". FASTEN MEMBERS WITH THREE ROWS OF 12d NAILS AT 16" O.C. FRAME DORMER WALLS ON TOP OF DOUBLE OR TRIPLE RAFTERS AS SHOWN (UNO).
- FOR TRUSSED ROOFS: FRAME DORMER WALLS ON TOP OF 2 x 4 LADDER FRAMING AT 24" O.C. BETWEEN ADJACENT ROOF TRUSSES. STICK FRAME OVER-FRAMED ROOF SECTIONS WITH 2 x 8 RIDGES, 2 x 6 RAFTERS AT 16" O.C. AND FLAT 2 x 10 VALLEYS (UNO).
- ALL 4 x 4 AND 6 x 6 POSTS TO BE INSTALLED WITH 100 LB CAPACITY UPLIFT CONNECTORS TOP AND BOTTOM (UNO). POSTS MAY BE SECURED USING ONE SIMPSON H6 OR L7912 UPLIFT CONNECTOR FASTENED TO THE BAND AT THE BOTTOM AND THE BEAM AT THE TOP OF EACH POST. ONE 16" SECTION OF SIMPSON C916 COIL STRAPPING WITH (8) 8d HDG NAILS AT EACH END MAY BE USED IN LIEU OF EACH TWIST STRAP IF DESIRED. FOR MASONRY OR CONCRETE FOUNDATION USE SIMPSON POST BASE.

SCALE NOTE:
LARGE FORMAT PRINTS ARE TO SCALE AS NOTED.
11" x 17" PRINTS ARE ONE HALF THE NOTED SCALE

**J.S. THOMPSON
ENGINEERING, INC**
333 EAST SIX FORKS ROAD, SUITE 180 RALEIGH, NC 27609
PHONE: (919) 789-9919 FAX: (919) 789-9921
N.C. LICENSE NO.: C-1733

HICKORY
DAVIDSON HOMES



12/29/2022

This sealed page is to be used in conjunction with a full plan set engineered by J.S. Thompson Engineering, Inc. only. Use of this individual sealed page within architectural pages or shop drawings by others is a punishable offense under N.C. Statute § 89C-23

DATE: DECEMBER 29, 2022
SCALE: 1/4" = 1'-0"
DRAWN BY: MAIN STREET DESIGNS
ENGINEERED BY: ZHH

D-5
STANDARD
STRUCTURAL NOTES

THIS LAYOUT IS INTENDED FOR THE PURPOSE OF TRUSS LOCATION AND PLACEMENT ONLY. REFER TO THE BUILDING PLANS FOR ACTUAL BUILDING CONSTRUCTION.



DEDICATED TO QUALITY AND EXCELLENCE
200 EMMETT ROAD
DUNN, NORTH CAROLINA 28334
PHONE: 910-892-8400

PROJECT: LOT 50 PRINCE PLACE

CUSTOMER: Davidson Homes

MODEL: HICKORY E - Floor

ORDER #: 38561A PRINT DATE: 7/24/2023 DRAWN BY: BES SCALE: N.T.S.

TOP LIVE LOAD: 40.0 lb/ft²
TOP DEAD LOAD: 10.0 lb/ft²
BOTTOM LIVE LOAD:
BOTTOM DEAD LOAD: 5.0 lb/ft²

GENERAL NOTES:
- DO NOT CUT OR MODIFY TRUSSES
- TRUSSES ARE SPACED 19.2" ON CENTER UNLESS OTHERWISE NOTED
- REFER TO THE INDIVIDUAL TRUSS DESIGN DRAWINGS FOR THE LOCATION OF LATERAL BRACING AND MULTI-PLY CONNECTION REQUIREMENTS.
- PER ANSI TPI 1-2002 THE TRUSS ENGINEER IS RESPONSIBLE FOR TRUSS TO TRUSS CONNECTIONS AND TRUSS PLY TO PLY CONNECTIONS. THIS TRUSS PLAN RECOMMENDS TRUSS TO BEARING CONNECTIONS AND TRUSS TO BEAM CONNECTIONS WHICH SHALL BE REVIEWED BY THE BUILDING DESIGNER. IT IS THE RESPONSIBILITY OF THE BUILDING DESIGNER TO RESOLVE ALL ROOF FORCES ADEQUATELY TO THE FOUNDATION.

Products				
PlotID	Length	Product	Plies	Net Qty
BM1	14-00-00	1-3/4" x 14" LVL BY OTHERS	2	2
BM3	8-00-00	1-3/4" x 14" LVL BY OTHERS	1	1
BM2	24-00-00	1-3/4" x 24" LVL BY OTHERS	3	3

HANGER LIST		
A	LUS410	40
B	-	-
C	-	-

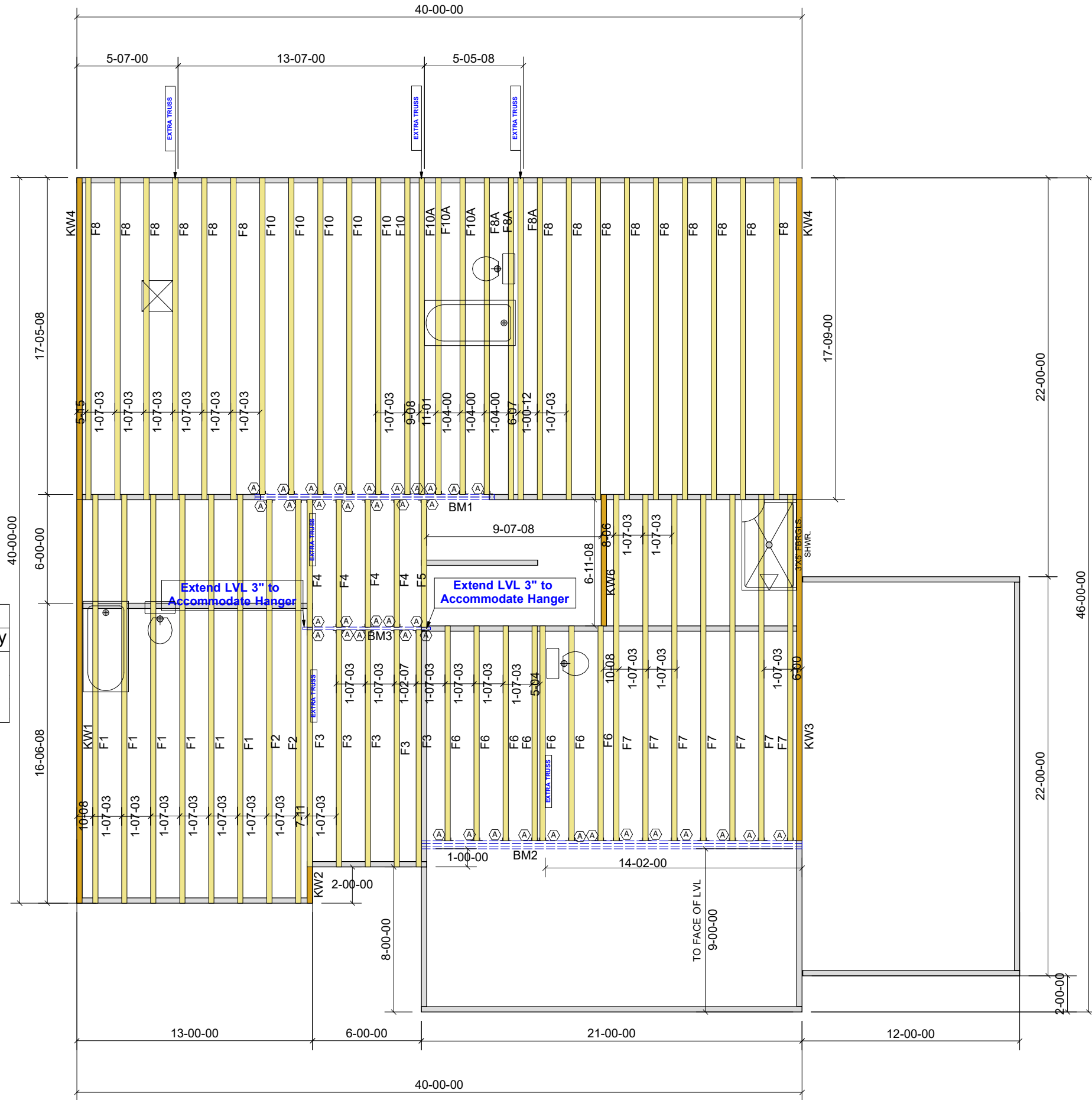

Crawl Level Floor Area	1st Level Floor Area	2nd Level Floor Area
0	1515.81	0

THIS LAYOUT IS INTENDED FOR THE PURPOSE OF TRUSS LOCATION AND PLACEMENT ONLY. REFER TO THE BUILDING PLANS FOR ACTUAL BUILDING CONSTRUCTION.



DEDICATED TO QUALITY AND EXCELLENCE
 200 EMMETT ROAD
 DUNN, NORTH CAROLINA 28334
 PHONE: 910-892-8400

PROJECT: LOT 50 PRINCE PLACE
 CUSTOMER: DAVIDSON HOMES
 MODEL: HICKORY E w/CvrdPrch - 3rd fl
 ORDER #: 38560A
 PRINT DATE: 7/24/2023
 DRAWN BY: BES
 SCALE: N.T.S

TOP LIVE LOAD: 20.0 lb/ft²
 TOP DEAD LOAD: 10.0 lb/ft²
 BOTTOM DEAD LOAD: 10.0 lb/ft²
 WIND SPEED: 115 mph

GENERAL NOTES:
 - DO NOT CUT OR MODIFY TRUSSES
 - TRUSSES ARE SPACED 24" ON CENTER UNLESS OTHERWISE NOTED
 - REFER TO THE INDIVIDUAL TRUSS DESIGN DRAWINGS FOR THE LOCATION OF LATERAL BRACING AND MULTI-PLY CONNECTION REQUIREMENTS.
 - PER ANSI TPI 1-2002 THE TRUSS ENGINEER IS RESPONSIBLE FOR TRUSS TO TRUSS CONNECTIONS AND TRUSS PLY TO PLY CONNECTIONS. THIS TRUSS PLAN RECOMMENDS TRUSS TO BEARING CONNECTIONS AND TRUSS TO BEAM CONNECTIONS WHICH SHALL BE REVIEWED BY THE BUILDING DESIGNER. IT IS THE RESPONSIBILITY OF THE BUILDING DESIGNER TO RESOLVE ALL ROOF FORCES ADEQUATELY TO THE FOUNDATION.

HANGER LIST		
A	LUS26	8
B	HUS26	8
C	HHUS26-2	2

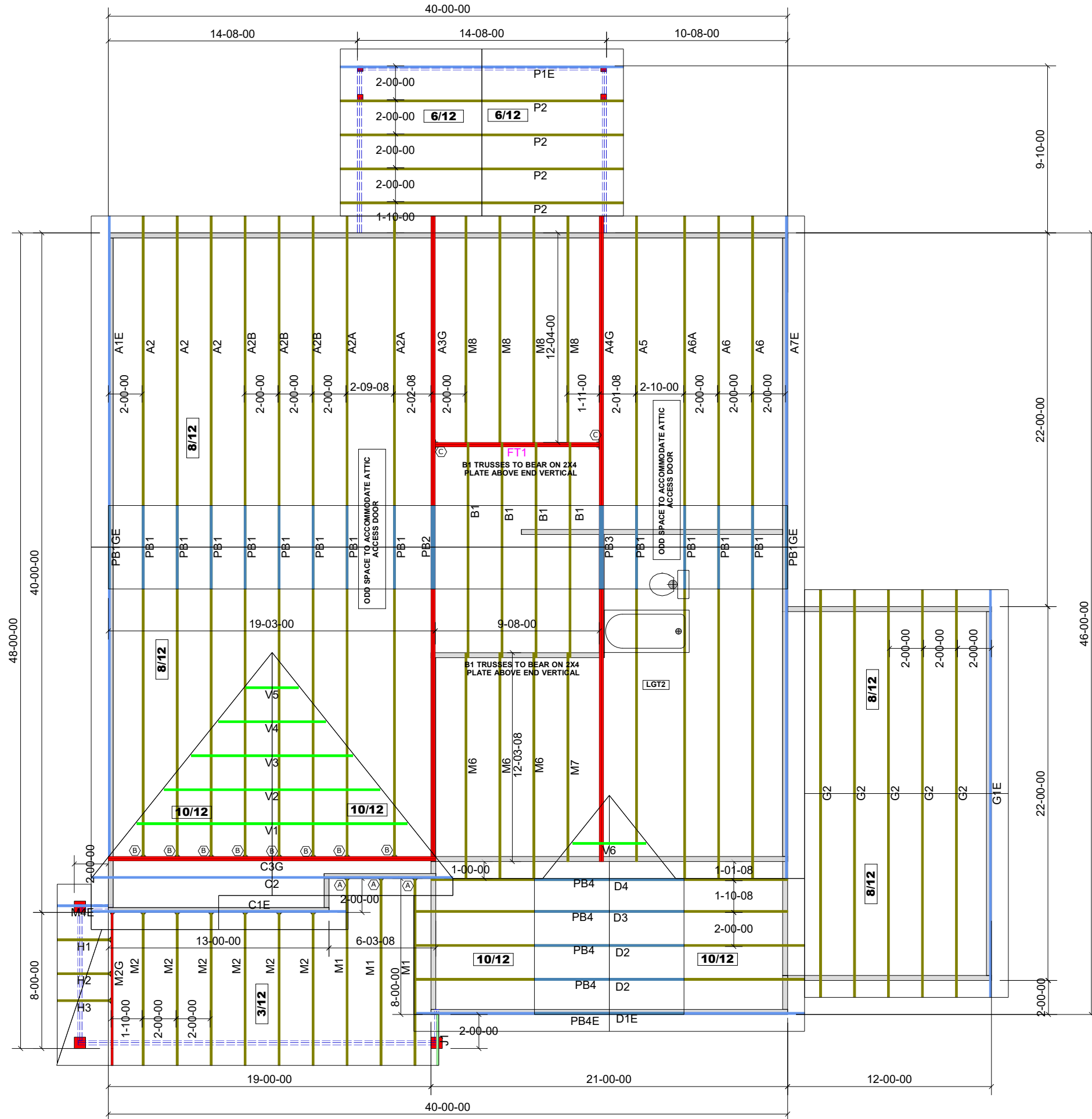

1st Level Roof Area 1015.39
 2nd Level Roof Area 2026.55