

GENERAL NOTES:

- IT IS THE CONTRACTORS RESPONSIBILITY TO VERIFY THAT ALL DIMENSIONS, ROOF PITCHES, AND SQUARE FOOTAGE ARE CORRECT PRIOR TO CONSTRUCTION. K&A HOME DESIGNS, INC. IS NOT RESPONSIBLE FOR ANY DIMENSIONING, ROOF PITCH, OR SQUARE FOOTAGE ERRORS ONCE CONSTRUCTION BEGINS.
- ALL WALLS SHOWN ON THE FLOOR PLANS ARE DRAWN AT 4" UNLESS NOTED OTHERWISE.
- ALL ANGLED WALL SHOWN ON THE PLANS ARE 45 DEGREES UNLESS NOTED OTHERWISE.
- STUD WALL DESIGN SHALL CONFORM TO ALL NORTH CAROLINA STATE BUILDING CODE REQUIREMENTS.
- DO NOT SCALE PLANS. DRAWING SCALE MAY BE DISTORTED DUE TO COPIER IMPERFECTIONS.
- ALL CONSTRUCTION SHALL BE IN ACCORDANCE WITH NORTH CAROLINA RESIDENTIAL STATE BUILDING CODE, 2018 EDITION.

SQUARE FOOTAGE

HEATED SQUARE FOOTAGE		UNHEATED SQUARE FOOTAGE	
FIRST FLOOR=	2089	GARAGE=	540
SECOND FLOOR=	605	FRONT PORCH=	166
THIRD FLOOR=	N/A	CVD. PORCH=	298
BASEMENT=	N/A	OPT. REC.=	329
		OPT. 3 RD CAR=	338
TOTAL HEATED=	2694	TOTAL UNHEATED=	1671

CRAWL SPACE VENTILATION CALCULATIONS

-VENT LOCATIONS MAY VARY FROM THOSE SHOWN ON THE PLAN BUT SHOULD BE PLACED TO PROVIDE ADEQUATE VENTILATION AT ALL POINTS TO PREVENT DEAD AIR POCKETS.

-100% VAPOR BARRIER MUST BE PROVIDED WITH 12" MIN. LAP JOINTS.

-THE TOTAL AREA OF VENTILATION OPENINGS MAY BE REDUCED TO 1/1500 AS LONG AS REQUIRED OPENINGS ARE PLACED SO AS TO PROVIDE CROSS-VENTILATION OF THE SPACE. THE INSTALLATION OF OPERABLE LOUVERS SHALL NOT BE PROHIBITED. (COMPLY WITH NC CODE MIN. WITH REGARD TO VENT PLACEMENT FROM CORNERS)

N/A SQ. FT. OF CRAWLSPACE/1500

N/A SQ. FT. OF REQUIRED VENTILATION

PROVIDED BY: N/A VENTS AT 0.45 SQ. FT. NET FREE

VENTILATION EACH= N/A SQ. FT. OF VENTILATION

****FOUNDATION DRAINAGE- WATERPROOFING PER SECTIONS 405 & 406.**

ATTIC VENTILATION CALCULATIONS

- CALCULATIONS SHOWN BELOW ARE BASED ON VENTILATORS USED AT LEAST 3 FT. ABOVE THE CORNICE VENTS WITH THE BALANCE OF VENTILATION PROVIDED BY EAVE VENTS.

- CATHEDRAL CEILINGS SHALL HAVE A MIN. 1" CLEARANCE BETWEEN THE BOTTOM OF THE ROOF DECK AND THE INSULATION.

3430 SQ. FT. OF ATTIC/300= 11.43

EACH OF INLET AND OUTLET REQUIRED.

***WALL AND ROOF CLADDING DESIGN VALUES**

- WALL CLADDING IS DESIGNED FOR A 24.1 SQ. FT. OR GREATER POSITIVE AND NEGATIVE PRESSURE.

- ROOF VALUES BOTH POSITIVE AND NEGATIVE SHALL BE AS FOLLOWS:

45.5 LBS. PER SQ. FT. FOR ROOF PITCHES OF 0/12 TO 2.25/12

34.8 LBS. PER SQ. FT. FOR ROOF PITCHES OF 2.25/12 TO 7/12

21 LBS. PER SQ. FT. FOR ROOF PITCHES OF 7/12 TO 12/12

**** MEAN ROOF HEIGHT 30' OR LESS**

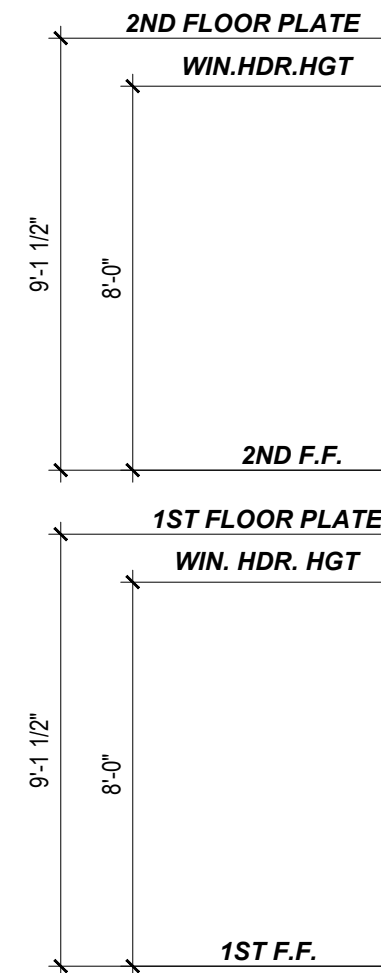

FRONT ELEVATION
1/4" = 1'-0"

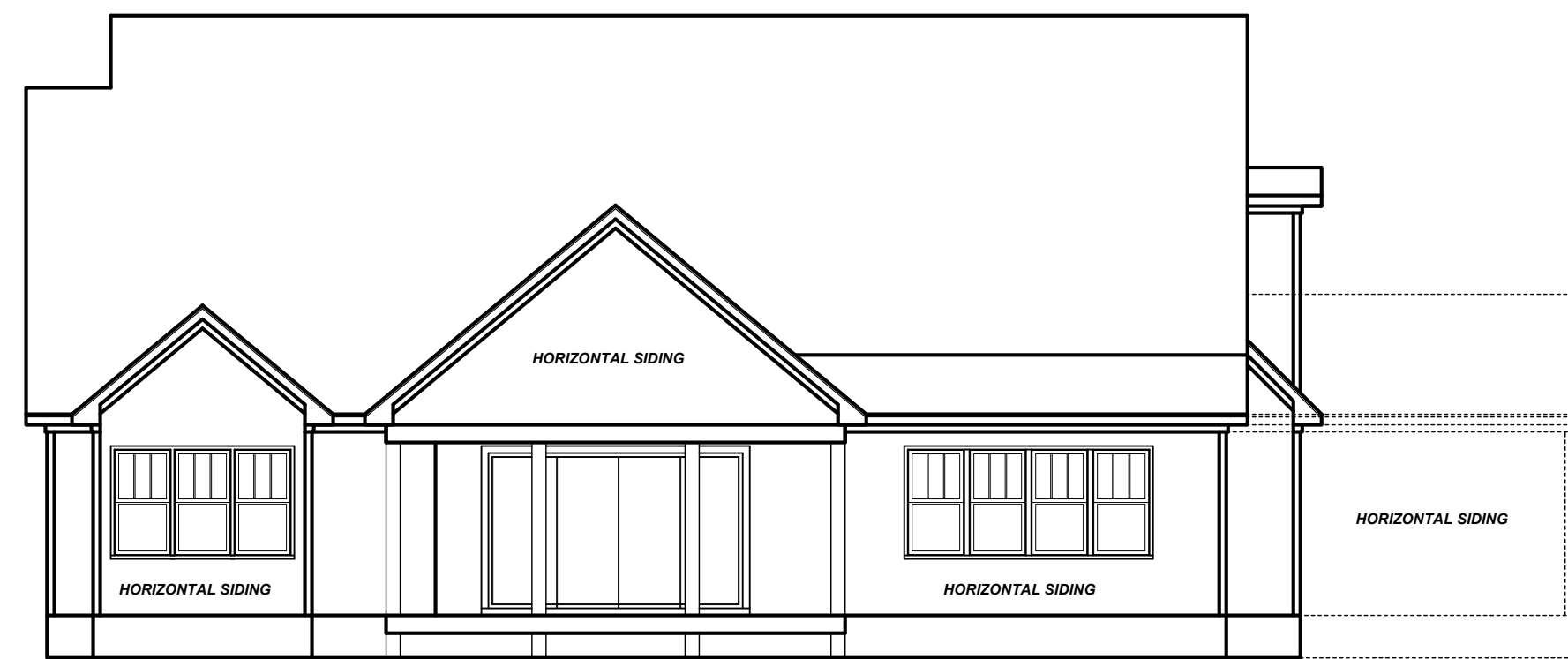

REAR ELEVATION
1/8" = 1'-0"



LEFT ELEVATION
1/8" = 1'-0"

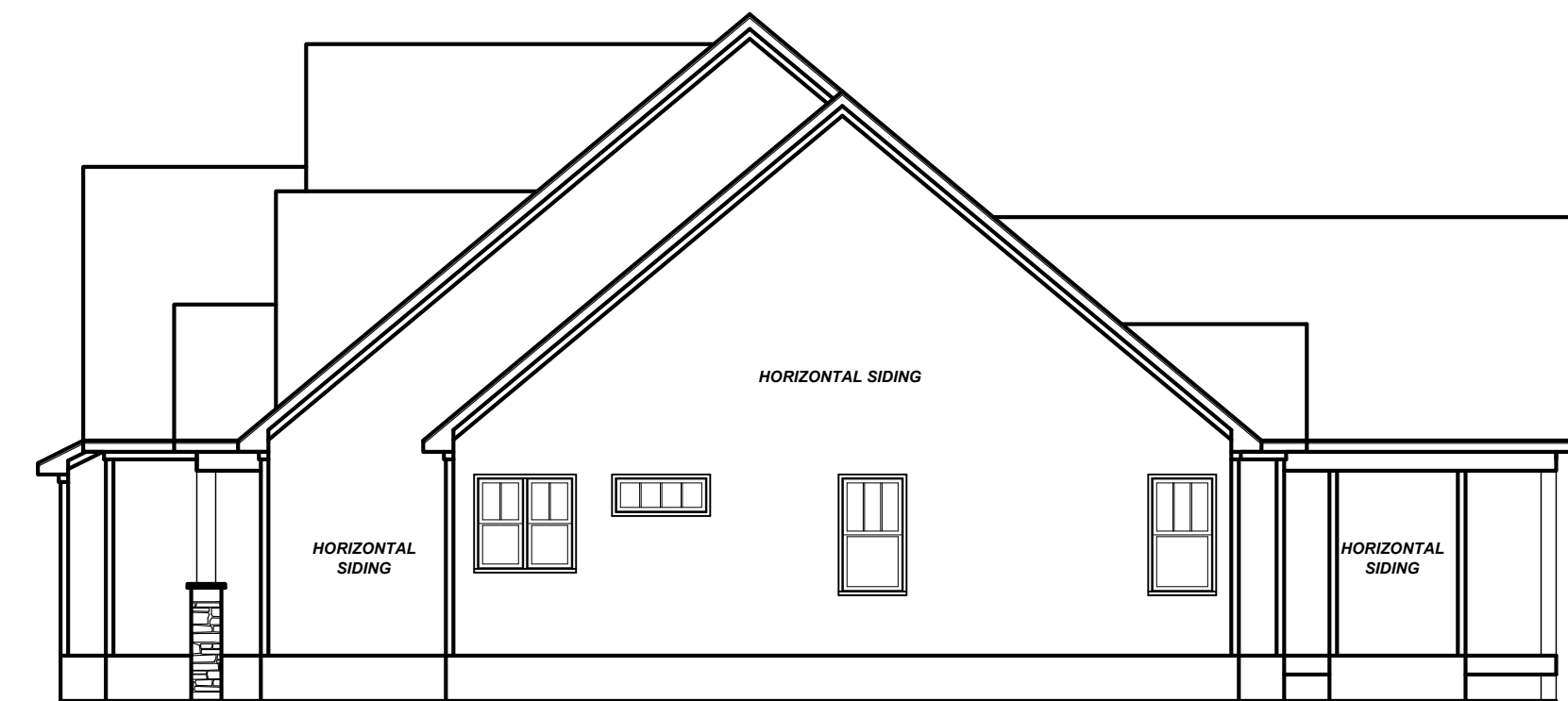

RIGHT ELEVATION
1/8" = 1'-0"

Project No.	23-018
Date	4-25-23
Drawn/Design By	KBB
Scale	REFER TO ELEV.

REVISIONS		
No.	Date	Remarks
1		
2		
3		
4		

9101 Ten-Ten Rd.
Raleigh, NC 27603
Office: (919) 302-0693



Website: www.KandAHomeDesigns.com

Email: Kent@KandAHomeDesigns.com



Porter Built Homes
6121 Catandpolly Ln.
Raleigh, NC 27603

ELEVATIONS

Sheet Number	1
	of 3

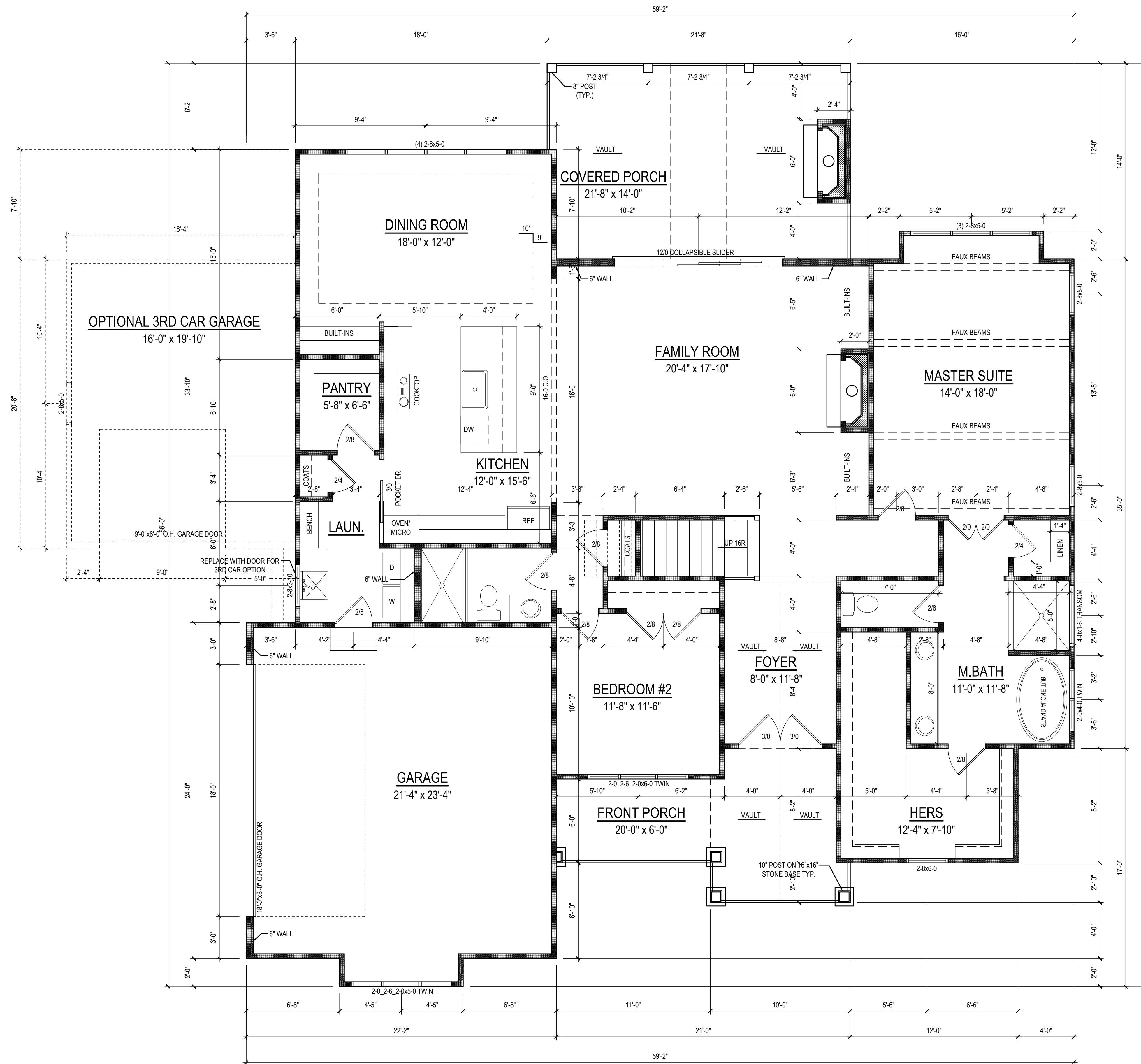

FIRST FLOOR PLAN
 1/4" = 1'-0" CEILING HT. = 9'-0"

Project No.	23-018
Date	4-25-23
Drawn/Design By	KBB
Scale	1/4" = 1'-0"

REVISIONS		
No.	Date	Remarks
1		
2		
3		
4		

9101 Ten-Ten Rd.
 Raleigh, NC 27603
 Office: (919) 302-0693



Email: Kent@KandAHomeDesigns.com Website: www.KandAHomeDesigns.com

Ryleigh

Porter Built Homes
 6121 Catandpolly Ln.
 Raleigh, NC 27603

FIRST FLOOR

Sheet Number
2
 of 3

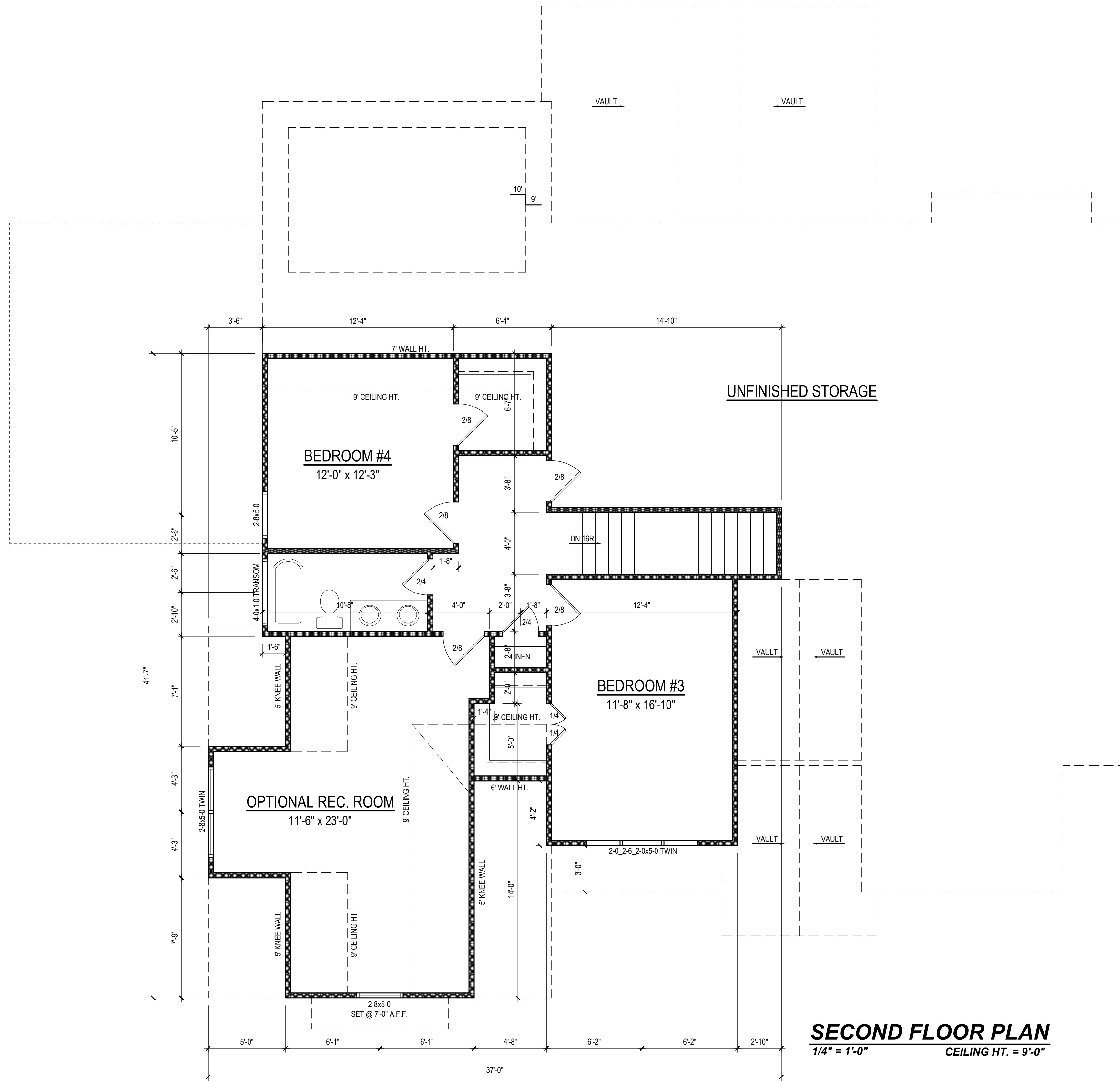

SECOND FLOOR PLAN
 1/4" = 1'-0" CEILING HT. = 9'-0"

Project #: 23-018
 Date: 4-25-23
 Drawn/Design: KBB
 Scale: 1/4" = 1'-0"

REVISIONS		
No.	Date	Remarks
1		
2		
3		
4		

9101 Ten-Ten Rd.
 Raleigh, NC 27603
 Office: (919) 302-0693



Email: Kent@KandAHomeDesigns.com Website: www.KandAHomeDesigns.com

Ryleigh

Porter Built Homes
 6121 Catandpolly Ln.
 Raleigh, NC 27603

SECOND FLOOR

Sheet Number
3
 of 3

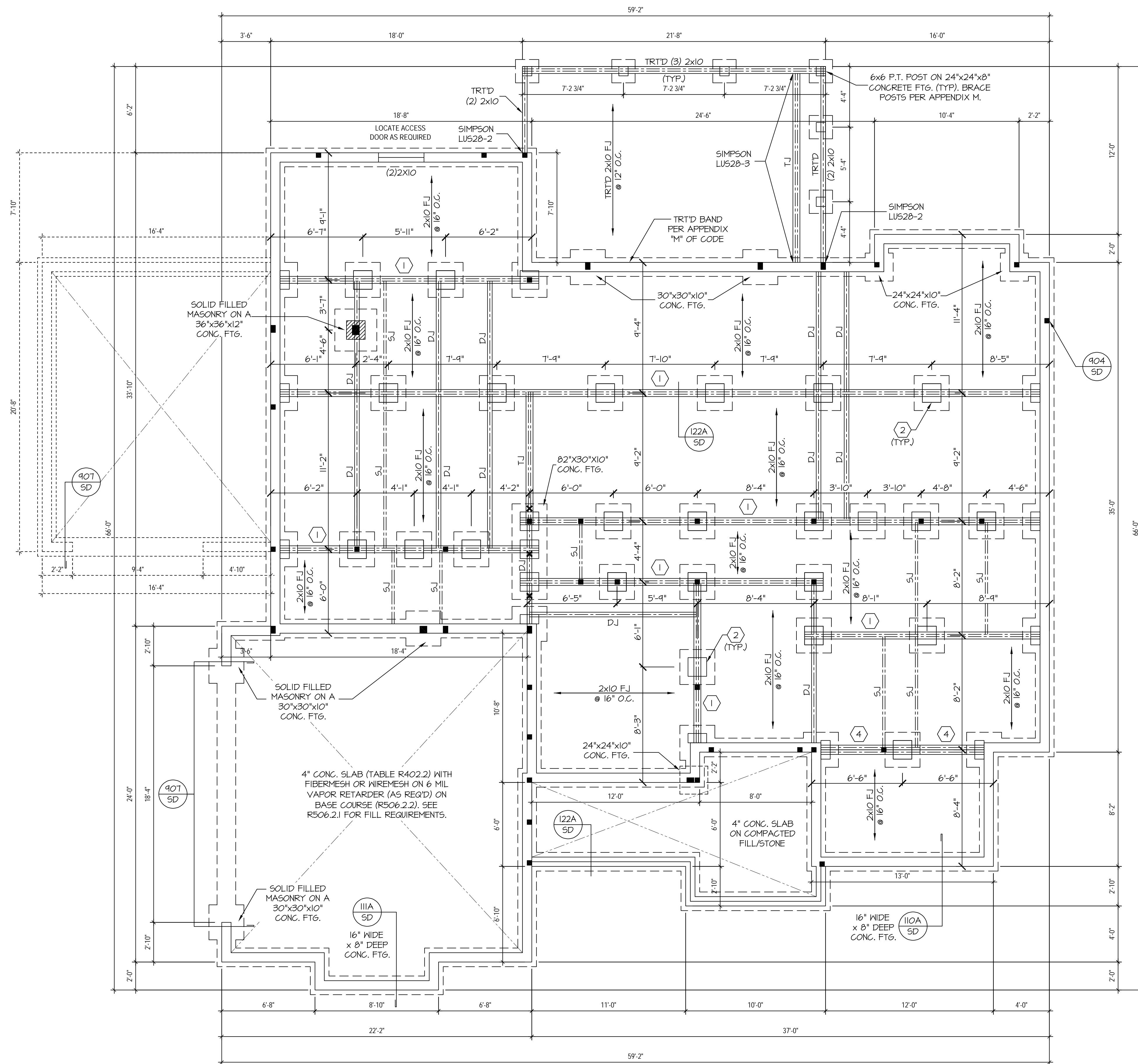

- FOUNDATION STRUCTURAL NOTES**
NC (2018 NCRS); Wind: 115-120 mph - GRAVIL
- ① (3) 2x10 SYP#2 OR SPF#2 GIRDER, TYPICAL UNO.
 - ② CONCRETE BLOCK PIER SIZE SHALL BE:

SIZE	ISOLATED	SOLID
8x16	UP TO 32'	UP TO 5'-0"
12x16	UP TO 48'	UP TO 9'-0"
16x16	UP TO 64'	UP TO 12'-0"
24x24	UP TO 96'	

 - WITH 30" x 30" x 10" CONCRETE FOOTING, UNO.
 - ③ WALL FOOTING AS FOLLOWS
 - DEPTH: 8" - UP TO 2 STORY
 - 10" - 3 STORY
 - WIDTH: 16" - UP TO 2 STORY
 - 20" - 3 STORY
 - BRICK: 16" - 1 STORY
 - 20" - 2 STORY
 - 24" - 3 STORY
 - FOR FOUNDATION WALL HEIGHT AND BACKFILL REQUIREMENTS, REFER TO CODE TABLE R404.11 (1 THRU 4) NOTE: ASSUMED SOIL BEARING CAPACITY = 2000 PSF. CONTRACTOR MUST VERIFY SITE CONDITIONS AND CONTACT SOILS ENGINEER IF MARGINAL OR UNSTABLE SOILS ARE ENCOUNTERED.
 - ④ (4) 2x10 SPF #2 OR SYP #2 GIRDER
 - ⑤ (2) 1.75x4.25 LVL OR LSL GIRDER
 - ⑥ (3) 1.75x4.25 LVL OR LSL GIRDER
 1. ■ DESIGNATES A SIGNIFICANT POINT LOAD TO HAVE SOLID BLOCKING TO PIER. SOLID BLOCK ALL BEAM BEARING POINTS NOTED TO HAVE THREE OR MORE STUDS TO END, TYPICAL.
 8. ABBREVIATIONS:
 - "SJ" = SINGLE JOIST
 - "DJ" = DOUBLE JOIST
 - "TJ" = TRIPLE JOIST
 9. ADJUST SUBFLOOR THICKNESS OR JOIST SPACING AS REQ'D FOR FLOOR FINISH MATERIALS.

FRAMING NOTE: ALL DIMENSIONAL LUMBER ON THIS SHEET MAY BE SPF #2 OR SYP #2, UNLESS SPECIFICALLY NOTED OTHERWISE.

THE STRUCTURAL DESIGN OF THIS PLAN IS THE PROPERTY OF SOUTHERN ENGINEERS, P.A. AND IS FOR ONE TIME USE FOR THE CLIENT AND LOCATION NOTED. SOUTHERN ENGINEERS, P.A. ASSUMES NO LIABILITY FOR THIS PLAN IF IT IS REPRODUCED AND/OR USED, IN WHOLE OR IN PART, FOR CONSTRUCTION AT ANY OTHER LOCATION WITHOUT WRITTEN PERMISSION FROM SOUTHERN ENGINEERS, P.A. THESE PLANS SHALL BE REVIEWED BY DESIGNER, BUILDER, AND/OR OWNER FOR CONFORMANCE WITH THE ARCHITECTURAL DESIGN CONCEPT PROVIDED. ALL DIMENSIONS SHALL BE VERIFIED BY DESIGNER, BUILDER, AND/OR OWNER PRIOR TO CONSTRUCTION.

SEALED CRAWLSPACE FOUNDATION STRUCTURAL PLAN

SCALE: 1/4" = 1'-0"
REFER TO "SD" SHEET(S) FOR STANDARD DETAILS AND STRUCTURAL NOTES

Engineers seal applies only to structural components on this document.
Seal does not include construction means, methods, techniques, sequences, procedures or safety precautions.
Any deviations or discrepancies on plans are to be brought to the immediate attention of Southern Engineers. Failure to do so will void Southern Engineers' liability.
Seal is valid for projects permitted one year from date of seal.
Use of these plans constitutes approval of terms & conditions as defined in the customer agreement.

Southern Engineers, P.A.
3716 Benson Drive, Raleigh, NC 27609
Phone: (919) 878-1617
License: C-4772
www.southernengineers.com

K&A HOME DESIGN, INC.

Lot 43, Cotton Farm
Ryleigh - Garage Left
PORTER BUILT HOMES

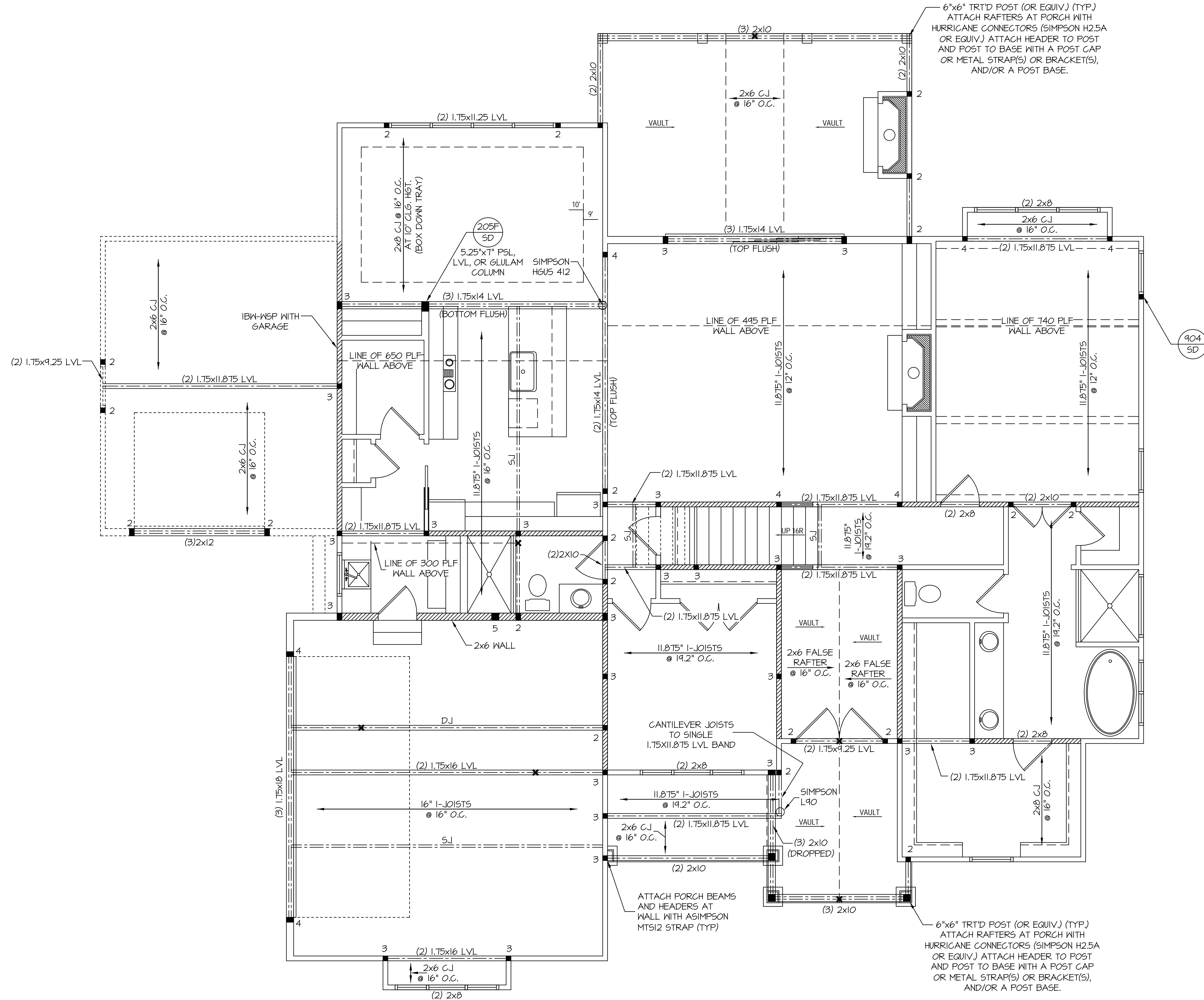
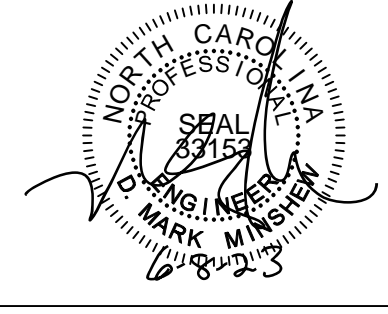

- FRAMING NOTES**
NC (2018 NGR.C): Wind: 115-120 mph
- BRACING METHOD AND TYPE: CONTINUOUSLY SHEATHED WSP, CS-WSP. NOTE THAT THE WALL BRACING AMOUNT PROVIDED ON THE PLANS (DETAILS AND SPECIFICATIONS) IS GREATER THAN THE AMOUNT OF WALL BRACING REQUIRED BY SECTION R602.10 OF THE CODE. SEE NOTES BELOW FOR DETAILS AND SPECIFICATIONS FOR WALL BRACING AND WALL FRAMING.
 - EXTERIOR WALL SHEATHING: WALLS SHALL BE BRACED BY SHEATHING WALLS ON ALL STORIES WITH WOOD STRUCTURAL PANEL SHEATHING (WSP) (EXPOSURE B: 1/16", EXPOSURE C: 15/32"). SHEATHING SHALL BE ATTACHED WITH 8d NAILS AT A 6"/12" NAILING PATTERN (6" OC AT PANEL EDGES AND 12" OC AT INTERMEDIATE SUPPORTS). INSTALL BLOCKING AT ALL PANEL EDGES.
 - WSP SHEATHING SHALL EXTEND TO THE UPPERMOST DOUBLE BEARING PLATE. BLOCK AT ROOF PER SECTION R602.10.4.5 AND ATTACH BRACED WALLS PER CODE. WSP SHEATHING BETWEEN FLOORS SHALL BE SPLICED ALONG CONTINUOUS BAND OR THE WSP SHEATHING MAY BE SPLICED ACROSS STUDS (CONTINUOUS ACROSS FLOOR SYSTEM) WITH BLOCKING AT PANEL EDGES. (MINIMUM 12" BEYOND FLOOR BREAK) OR OTHER APPROVED METHOD.
 - "HD" = HOLD-DOWN: HOLD-DOWN DEVICE (NOTED AS "HD" ON PLANS) SHALL BE AN 800 POUND CAPACITY ASSEMBLY AS NOTED ON PLANS. SEE DETAILS FOR HD ASSEMBLY.
"SD" = SHEATHING DETAIL: USE "HD HOLD-DOWN DETAIL" ON SD SHEET (OR EQUIV.)
"IBW" = INTERIOR BRACED WALL: ATTACH BASE OF KING STUD WITH A SIMPSON CS20 OR CSH20 STRAP DOWN ACROSS THE BAND AND DOWN TO A STUD BELOW OR HEADER BELOW. EXTEND STRAP 1" MIN ALONG EACH STUD (OR HEADER) AND ATTACH EACH END W/ (1) 8d NAIL.
 - INTERIOR BRACED WALL: (NOTED AS "IBW" ON PLANS) ATTACH 1/2" GYPSUM BOARD (GB) ON EACH SIDE OF WALL WITH A MIN. OF 5d COOLER NAILS OR #6 SCREWS @ 7" O.C. ALONG THE EDGES AND AT INTERMEDIATE SUPPORTS.
 - INTERIOR BRACED WALL-WOOD STRUCTURAL PANEL: (NOTED AS "IBW-WSP" ON PLANS), ATTACH ONE SIDE WITH 3/8" WSP SHEATHING WITH 8d NAILS AT A 6"/12" NAILING PATTERN (6" OC AT PANEL EDGES AND 12" OC AT INTERMEDIATE SUPPORTS). INSTALL BLOCKING AT ALL PANEL EDGES. ATTACH GB OVER WSP AS REQUIRED. ATTACH OPPOSITE SIDE WITH 1/2" GB WITH A MIN. OF 5d COOLER NAILS OR #6 SCREWS @ 7" OC ALONG THE EDGES AND AT INTERMEDIATE SUPPORTS.

- HEADER/BEAM & COLUMN NOTES**
- ALL EXTERIOR AND LOAD BEARING HEADERS SHALL BE MIN. (2)2x6 (4" WALL) OR (3)2x6 (6" WALL) WITH (1) SUPPORT STUD, UNLESS NOTED OTHERWISE.
 - THE NUMBER SHOWN AT BEAM AND HEADER SUPPORTS INDICATES THE NUMBER OF SUPPORT STUDS REQUIRED IN STUD POCKET OR COLUMN. THE NUMBER OF KING STUDS AT EACH END OF HEADERS IN EXTERIOR WALLS SHALL BE ACCORDING TO ITEM "d" IN TABLE R602.3(5) OR AS BELOW PER NCD01 COMMENTARY "KING STUDS AT WALL OPENINGS" REVISED 1-9-2020.
 - UP TO 3' SPAN: (1) KING STUD
 - OVER 3' UP TO 6' SPAN: (2) KING STUDS
 - OVER 6' UP TO 9' SPAN: (3) KING STUDS
 - OVER 9' UP TO 12' SPAN: (4) KING STUDS
 - OVER 12' UP TO 15' SPAN: (5) KING STUDS

- WOOD I-JOISTS**
(SHALL BE ONE OF THE FOLLOWING):
- TJI 210 BY TRUS JOIST
 - LPI 20 PLUS BY LP
 - BCI 5000s 1.8 BY BC
 - BLI 40 BY ORCENTER
- ALL I-JOISTS SHALL BE INSTALLED ACCORDING TO MANUFACTURER'S SPECIFICATIONS.
- INSTALL SQUASH BLOCKS, WEB STIFFENERS, ETC. AS REQUIRED BY AND ACCORDING TO THE I-JOIST MANUFACTURER'S SPECIFICATIONS AND INSTRUCTIONS.
- HANGERS FOR I-JOISTS ARE THE RESPONSIBILITY OF THE I-JOIST SUPPLIER.

FRAMING NOTE: ALL DIMENSIONAL LUMBER ON THIS SHEET MAY BE SPF #2 OR SYP #2, UNLESS SPECIFICALLY NOTED OTHERWISE.

THE STRUCTURAL DESIGN OF THIS PLAN IS THE PROPERTY OF SOUTHERN ENGINEERS, P.A. AND IS FOR ONE TIME USE FOR THE CLIENT AND LOCATION NOTED. SOUTHERN ENGINEERS, P.A. ASSUMES NO LIABILITY FOR THIS PLAN IF IT IS REPRODUCED AND/OR USED, IN WHOLE OR IN PART, FOR CONSTRUCTION AT ANY OTHER LOCATION WITHOUT WRITTEN PERMISSION FROM SOUTHERN ENGINEERS, P.A. THESE PLANS SHALL BE REVIEWED BY DESIGNER, BUILDER, AND/OR OWNER FOR CONFORMANCE WITH THE ARCHITECTURAL DESIGN CONCEPT PROVIDED. ALL DIMENSIONS SHALL BE VERIFIED BY DESIGNER, BUILDER, AND/OR OWNER PRIOR TO CONSTRUCTION.

Engineers seal applies only to structural components on this document.
Seal does not include construction means, methods, techniques, sequences, procedures or safety precautions.
Any deviations or discrepancies on plans are to be brought to the immediate attention of Southern Engineers. Failure to do so will void Southern Engineers' liability.
Seal is valid for projects permitted one year from date of seal.
Use of these plans constitutes approval of terms & conditions as defined in the customer agreement.

Southern Engineers, P.A.
3716 Benson Drive, Raleigh, NC 27609
Phone: (919) 878-1617
License: C-4772
www.southernengineers.com

K&A HOME DESIGN, INC.

Lot 43, Cotton Farm
Ryleigh - Garage Left
PORTER BUILT HOMES

FIRST FLOOR STRUCTURAL PLAN

SCALE: 1/4" = 1'-0"

REFER TO "SD" SHEET(S) FOR STANDARD DETAILS AND STRUCTURAL NOTES



FRAMING NOTES

NC (2018 NRC): Wind: 115-120 mph

- BRACING METHOD AND TYPE: CONTINUOUSLY SHEATHED WSP, CS-WSP. NOTE THAT THE WALL BRACING AMOUNT PROVIDED ON THE PLANS (DETAILS AND SPECIFICATIONS) IS GREATER THAN THE AMOUNT OF WALL BRACING REQUIRED BY SECTION R602.10 OF THE CODE. SEE NOTES BELOW FOR DETAILS AND SPECIFICATIONS FOR WALL BRACING AND WALL FRAMING.
- EXTERIOR WALL SHEATHING: WALLS SHALL BE BRACED BY SHEATHING WALLS ON ALL STORIES WITH WOOD STRUCTURAL PANEL SHEATHING (WSP) (EXPOSURE B: 1/8", EXPOSURE C: 15/32"). SHEATHING SHALL BE ATTACHED WITH 8d NAILS AT A 6"/12" NAILING PATTERN (6" OC AT PANEL EDGES AND 12" OC AT INTERMEDIATE SUPPORTS). INSTALL BLOCKING AT ALL PANEL EDGES.
- WSP SHEATHING SHALL EXTEND TO THE UPPERMOST DOUBLE BEARING PLATE. BLOCK AT ROOF PER SECTION R602.10.4.5 AND ATTACH BRACED WALLS PER CODE. WSP SHEATHING BETWEEN FLOORS SHALL BE SPLICED ALONG CONTINUOUS BAND OR THE WSP SHEATHING MAY BE SPLICED ACROSS STUDS (CONTINUOUS ACROSS FLOOR SYSTEM) WITH BLOCKING AT PANEL EDGES. (MINIMUM 12" BEYOND FLOOR BREAK) OR OTHER APPROVED METHOD.
- "HD" = HOLD-DOWN: HOLD-DOWN DEVICE (NOTED AS "HD" ON PLANS) SHALL BE AN 800 POUND CAPACITY ASSEMBLY AS NOTED ON PLANS. SEE DETAILS FOR HD ASSEMBLY.
 - **GROUND/FIRST FLOOR: USE "HD HOLD-DOWN DETAIL" ON SD SHEET (OR EQUIV.)
 - **UPPER FLOORS: ATTACH BASE OF KING STUD WITH A SIMPSON C520 OR C5HP20 STRAP DOWN ACROSS THE BAND AND DOWN TO A STUD BELOW OR HEADER BELOW. EXTEND STRAP 1" MIN ALONG EACH STUD (OR HEADER) AND ATTACH EACH END W/ (1) 8d NAILS.
- INTERIOR BRACED WALL: (NOTED AS "IBW" ON PLANS) ATTACH 1/2" GYPSUM BOARD (GB) ON EACH SIDE OF WALL WITH A MIN. OF 5d COOLER NAILS OR #6 SCREWS @ 7" O.C. ALONG THE EDGES AND AT INTERMEDIATE SUPPORTS.
- INTERIOR BRACED WALL-WOOD STRUCTURAL PANEL: (NOTED AS "IBW-WSP" ON PLANS). ATTACH ONE SIDE WITH 3/8" WSP SHEATHING WITH 8d NAILS AT A 6"/12" NAILING PATTERN (6" OC AT PANEL EDGES AND 12" OC AT INTERMEDIATE SUPPORTS). INSTALL BLOCKING AT ALL PANEL EDGES. ATTACH GB OVER WSP AS REQUIRED. ATTACH OPPOSITE SIDE WITH 1/2" GB WITH A MIN. OF 5d COOLER NAILS OR #6 SCREWS @ 7" OC ALONG THE EDGES AND AT INTERMEDIATE SUPPORTS.

HEADER/BEAM & COLUMN NOTES

- ALL EXTERIOR AND LOAD BEARING HEADERS SHALL BE MIN. (2)2x6 (4" WALL) OR (3)2x6 (6" WALL) WITH (1) SUPPORT STUD, UNLESS NOTED OTHERWISE.
- THE NUMBER SHOWN AT BEAM AND HEADER SUPPORTS INDICATES THE NUMBER OF SUPPORT STUDS REQUIRED IN STUD POCKET OR COLUMN. THE NUMBER OF KING STUDS AT EACH END OF HEADERS IN EXTERIOR WALLS SHALL BE ACCORDING TO ITEM "d" IN TABLE R602.3(5) OR AS BELOW PER NCD01 COMMENTARY "KING STUDS AT WALL OPENINGS" REVISED 1-9-2020.
 - UP TO 3' SPAN: (1) KING STUD
 - OVER 3' UP TO 6' SPAN: (2) KING STUDS
 - OVER 6' UP TO 9' SPAN: (3) KING STUDS
 - OVER 9' UP TO 12' SPAN: (4) KING STUDS
 - OVER 12' UP TO 15' SPAN: (5) KING STUDS

FRAMING NOTE: ALL DIMENSIONAL LUMBER ON THIS SHEET MAY BE SPF #2 OR SYP #2, UNLESS SPECIFICALLY NOTED OTHERWISE.

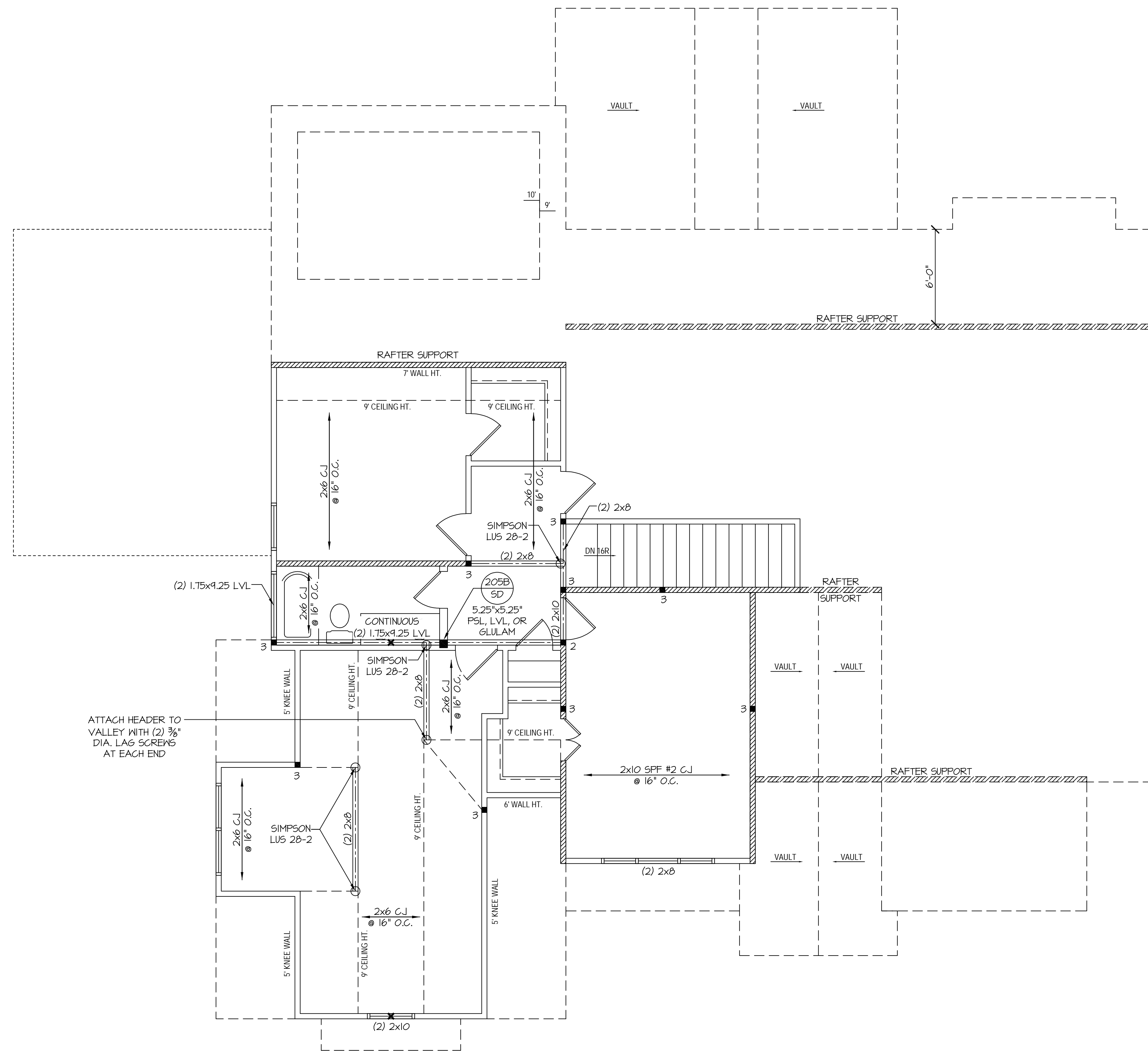

THE STRUCTURAL DESIGN OF THIS PLAN IS THE PROPERTY OF SOUTHERN ENGINEERS, P.A. AND IS FOR ONE TIME USE FOR THE CLIENT AND LOCATION NOTED. SOUTHERN ENGINEERS, P.A. ASSUMES NO LIABILITY FOR THIS PLAN IF IT IS REPRODUCED AND/OR USED, IN WHOLE OR IN PART, FOR CONSTRUCTION AT ANY OTHER LOCATION WITHOUT WRITTEN PERMISSION FROM SOUTHERN ENGINEERS, P.A. THESE PLANS SHALL BE REVIEWED BY DESIGNER, BUILDER, AND/OR OWNER FOR CONFORMANCE WITH THE ARCHITECTURAL DESIGN CONCEPT PROVIDED. ALL DIMENSIONS SHALL BE VERIFIED BY DESIGNER, BUILDER, AND/OR OWNER PRIOR TO CONSTRUCTION.

SECOND FLOOR STRUCTURAL PLAN

SCALE: 1/4" = 1'-0"
REFER TO "SD" SHEET(S) FOR STANDARD DETAILS AND STRUCTURAL NOTES

Engineers seal applies only to structural components on this document.
Seal does not include construction means, methods, techniques, sequences, procedures or safety precautions.
Any deviations or discrepancies on plans are to be brought to the immediate attention of Southern Engineers. Failure to do so will void Southern Engineers' liability.
Seal is valid for projects permitted one year from date of seal.
Use of these plans constitutes approval of terms & conditions as defined in the customer agreement.

Southern Engineers, P.A.
3716 Benson Drive, Raleigh, NC 27609
Phone: (919) 878-1617
License: C-4772
www.southernengineers.com

K&A HOME DESIGN, INC.

Lot 43, Cotton Farm
Ryleigh - Garage Left
PORTER BUILT HOMES

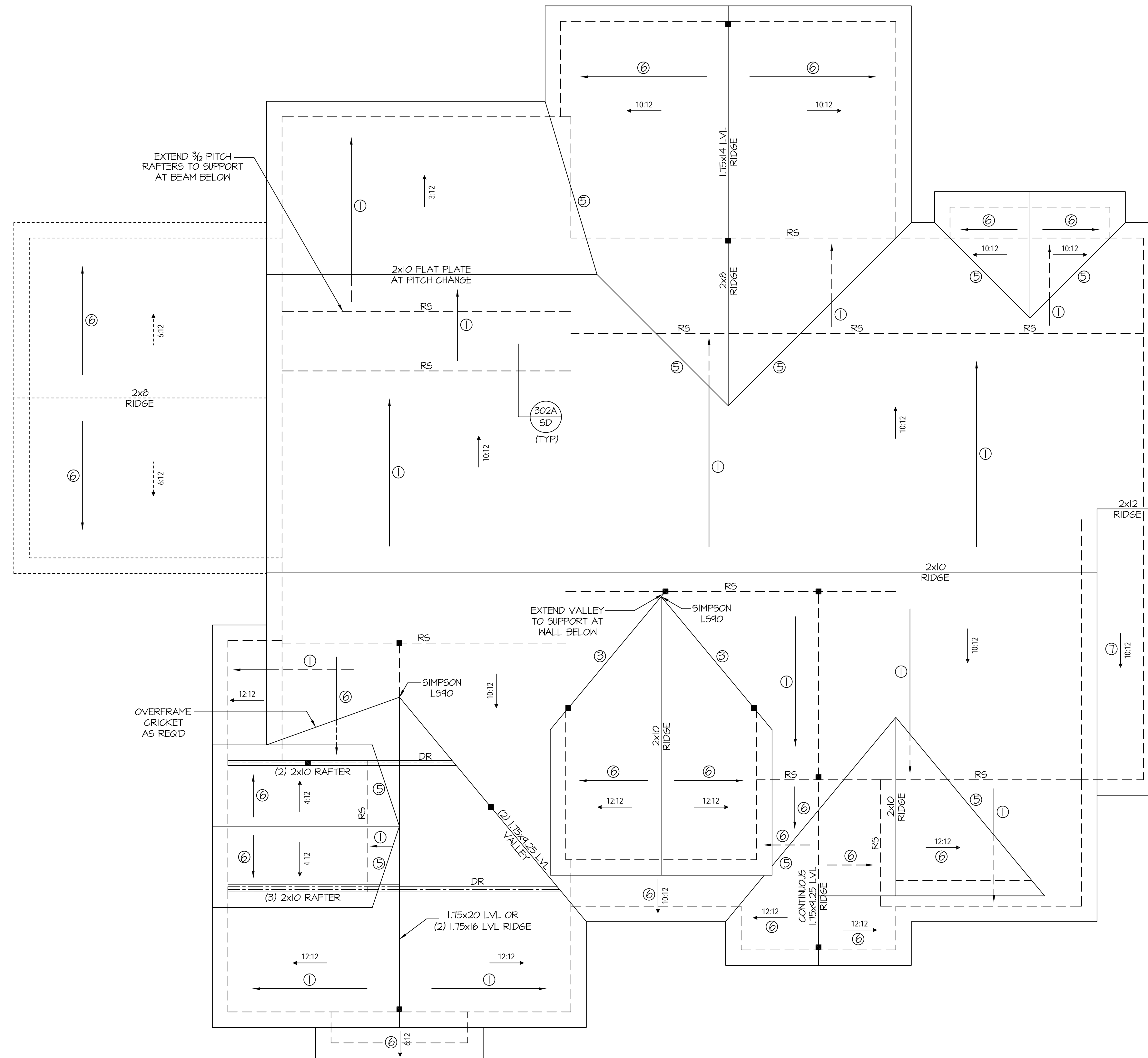

ROOF FRAMING NOTES:

NC (2018 NRC): Wind: 115-120 mph

- ① 2x8 RAFTERS @ 16" O.C. WITH 2x10 RIDGE, UNO.
 - ② (2) 2x10 OR 1.75x11.875 LVL HIP, (2) 2x10 HIPs MAY BE SPLICED WITH A MIN. 6'-0" OVERLAP AT CENTER.
 - ③ (2) 2x10 OR 1.75x9.25 LVL VALLEY. DO NOT SPLICE VALLEYS.
 - ④ 1.75x11.875 LVL OR (2) 1.75x9.25 LVL VALLEY.
 - ⑤ FALSE FRAME VALLEY ON 2x10 FLAT PLATE.
 - ⑥ 2x6 RAFTERS @ 16" O.C. W/ 2x8 RIDGE, UNO.
 - ⑦ 2x10 RAFTERS @ 16" O.C. W/ 2x12 RIDGE, UNO.
 - ⑧ EXTEND RIDGE 12" BEYOND INTERSECTION.
- "SR" = SINGLE RAFTER
 - "DR" = DOUBLE RAFTER
 - "TR" = TRIPLE RAFTER
 - "RS" = ROOF SUPPORT
 - "■" = (3) STUD OR 4x4 POST FOR ROOF SUPPORT (USE 2x6 STUDS OR 6x6 POST FOR SUPPORT OVER 10'-0" IN HEIGHT)
 - ATTACH VAULTED RAFTERS WITH HURRICANE CLIPS; SIMPSON "H-25A" OR EQUIVALENT. TIES TO BE INSTALLED ON THE OUTSIDE FACE OF FRAMING.
 - INSTALL RAFTER TIES AND COLLAR TIES PER SECTION R802.3.1 OF THE 2018 NC RESIDENTIAL CODE.

FRAMING NOTE: ALL DIMENSIONAL LUMBER ON THIS SHEET MAY BE SPF #2 OR SYP #2, UNLESS SPECIFICALLY NOTED OTHERWISE.

THE STRUCTURAL DESIGN OF THIS PLAN IS THE PROPERTY OF SOUTHERN ENGINEERS, P.A. AND IS FOR ONE TIME USE FOR THE CLIENT AND LOCATION NOTED. SOUTHERN ENGINEERS, P.A. ASSUMES NO LIABILITY FOR THIS PLAN IF IT IS REPRODUCED AND/OR USED, IN WHOLE OR IN PART, FOR CONSTRUCTION AT ANY OTHER LOCATION WITHOUT WRITTEN PERMISSION FROM SOUTHERN ENGINEERS, P.A. THESE PLANS SHALL BE REVIEWED BY DESIGNER, BUILDER, AND/OR OWNER FOR CONFORMANCE WITH THE ARCHITECTURAL DESIGN CONCEPT PROVIDED. ALL DIMENSIONS SHALL BE VERIFIED BY DESIGNER, BUILDER, AND/OR OWNER PRIOR TO CONSTRUCTION.

Southern Engineers, P.A.
3716 Benson Drive, Raleigh, NC 27609
Phone: (919) 878-1617
License: C-4772
www.southernengineers.com

**K&A HOME
DESIGN, INC.**

Lot 43, Cotton Farm
Ryleigh - Garage Left
PORTER BUILT HOMES

ROOF STRUCTURAL PLAN

SCALE: 1/4" = 1'-0"

REFER TO "SD" SHEET(S) FOR STANDARD DETAILS AND STRUCTURAL NOTES

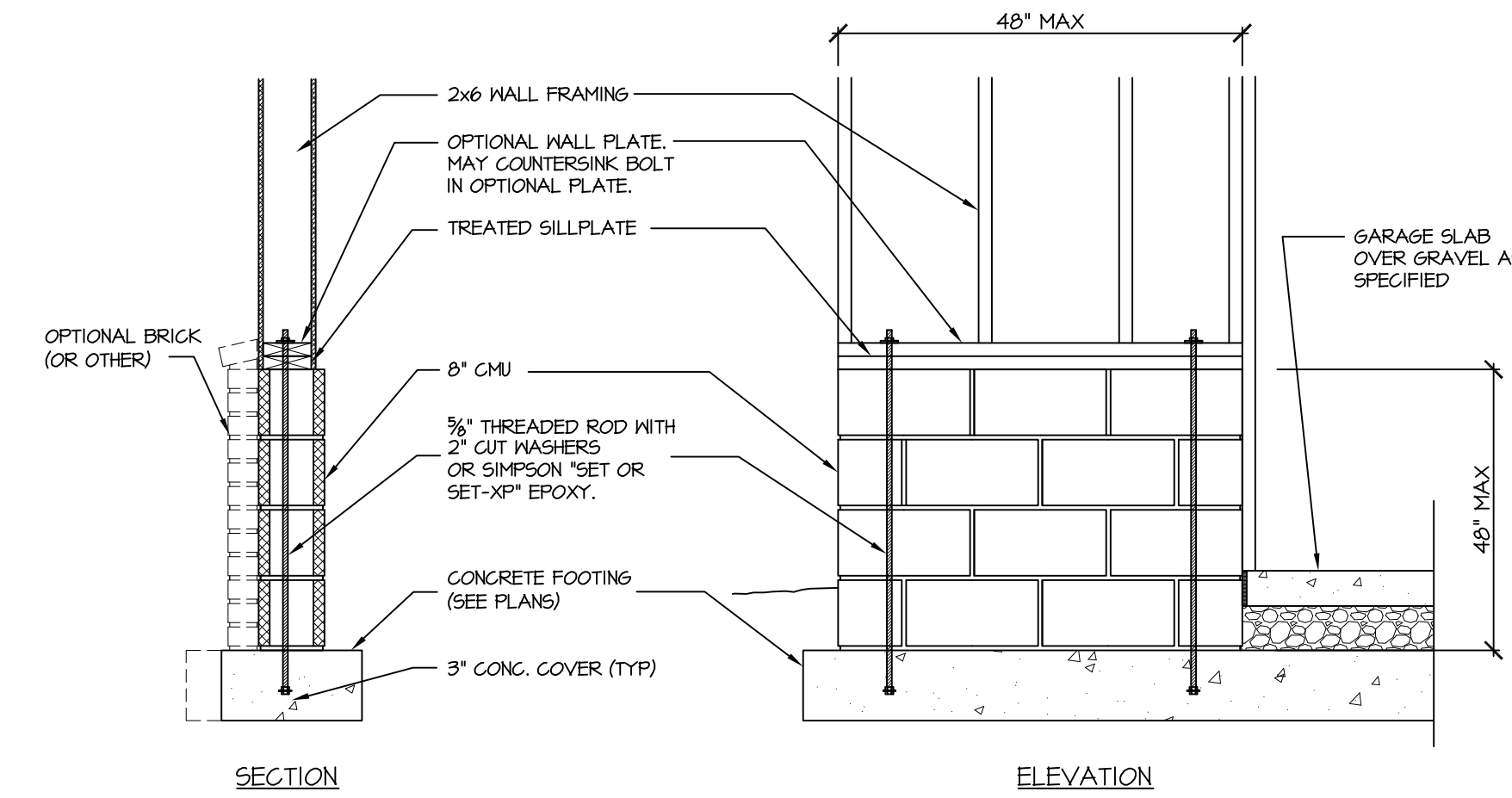
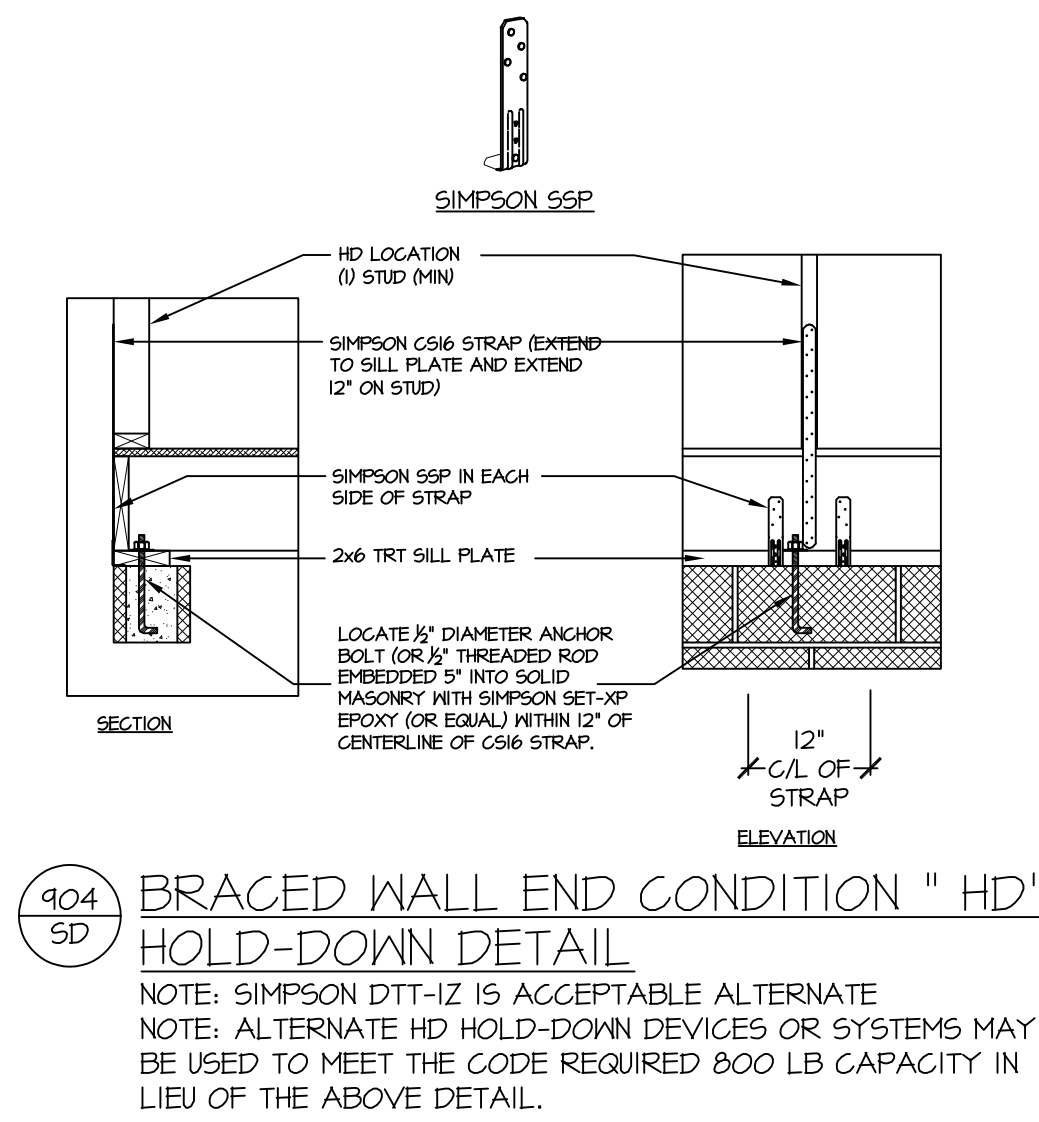
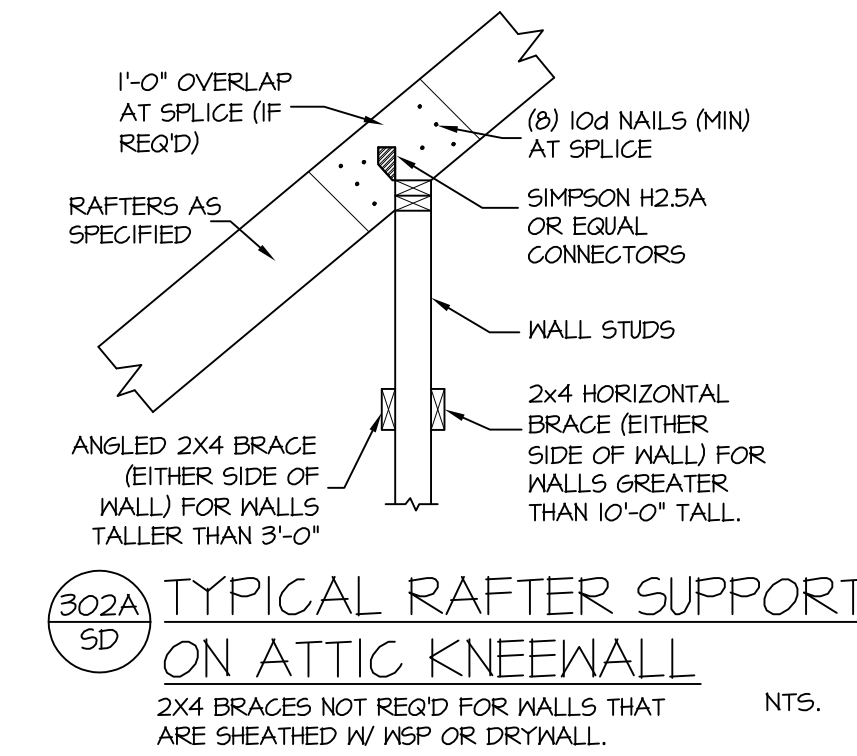
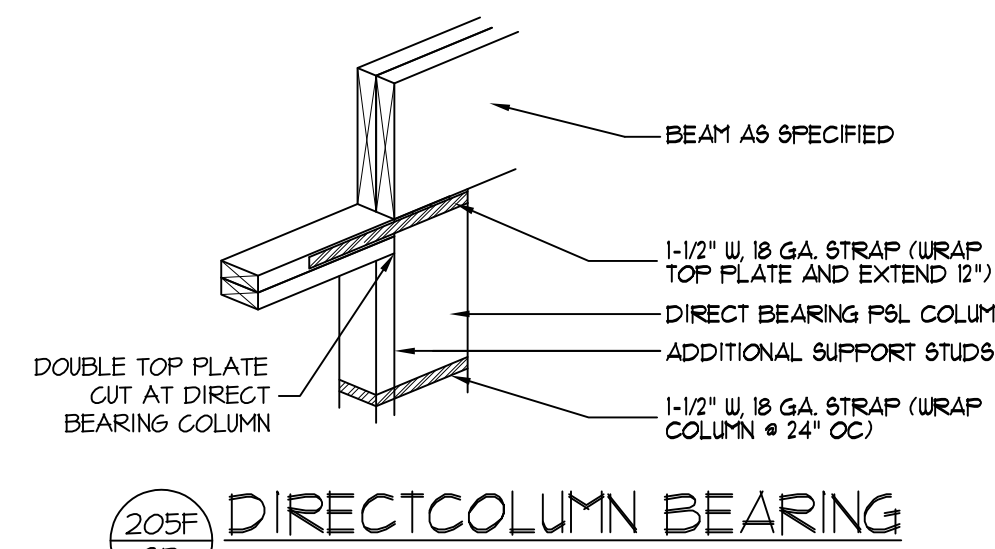
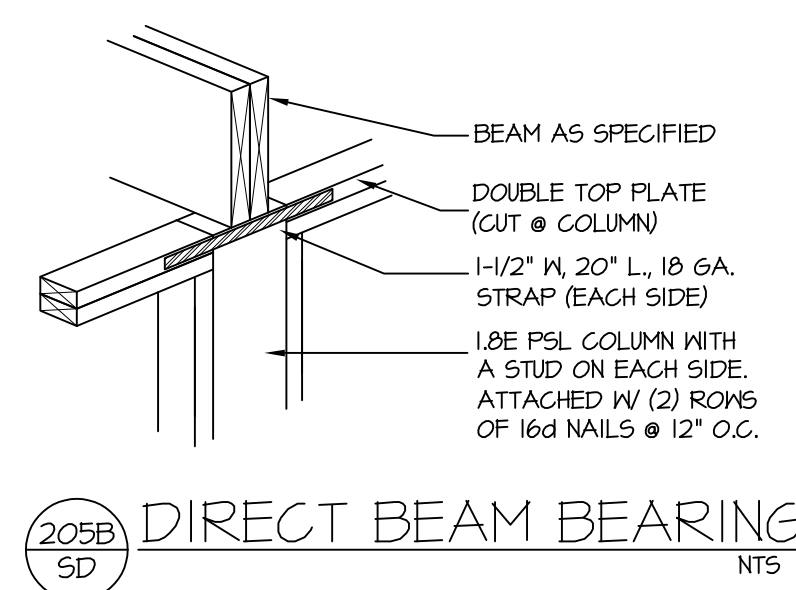
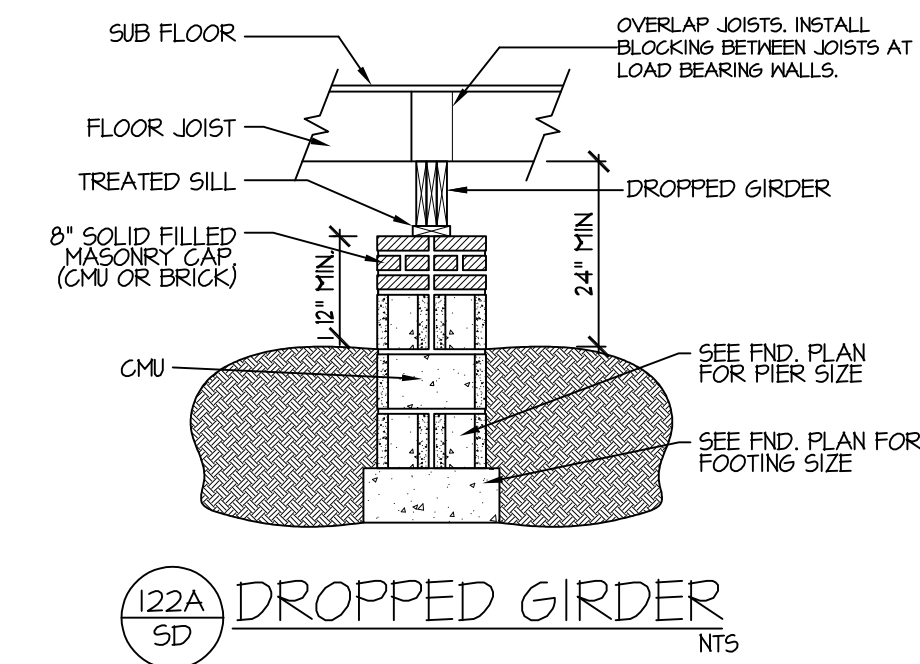
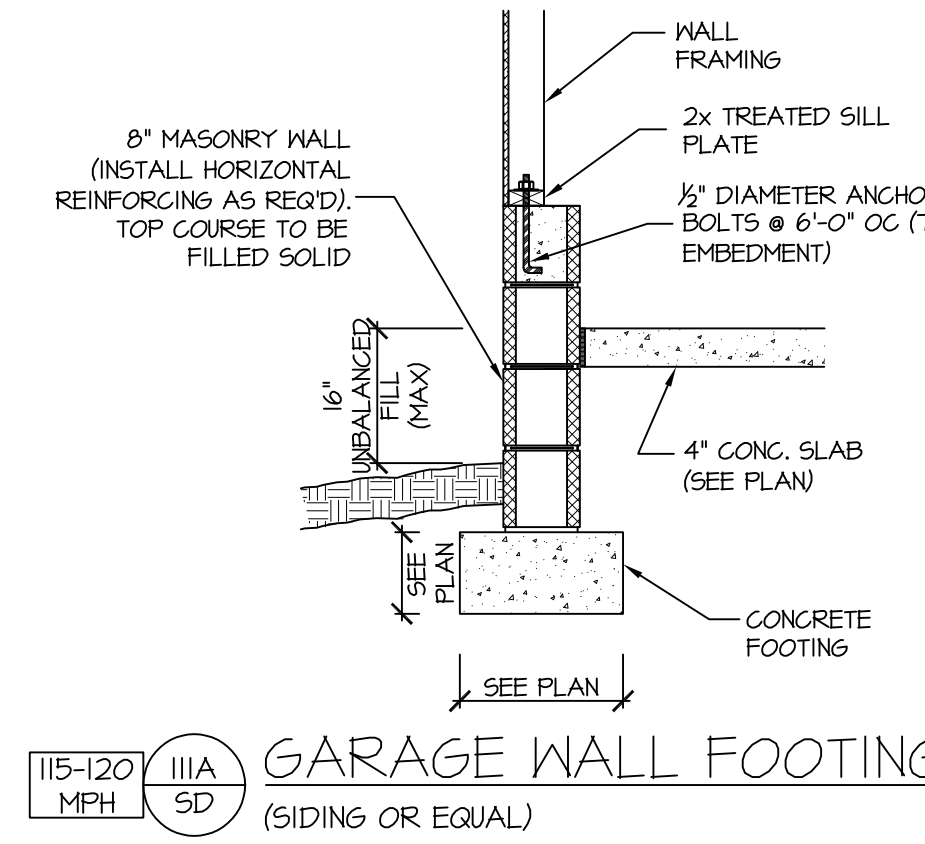
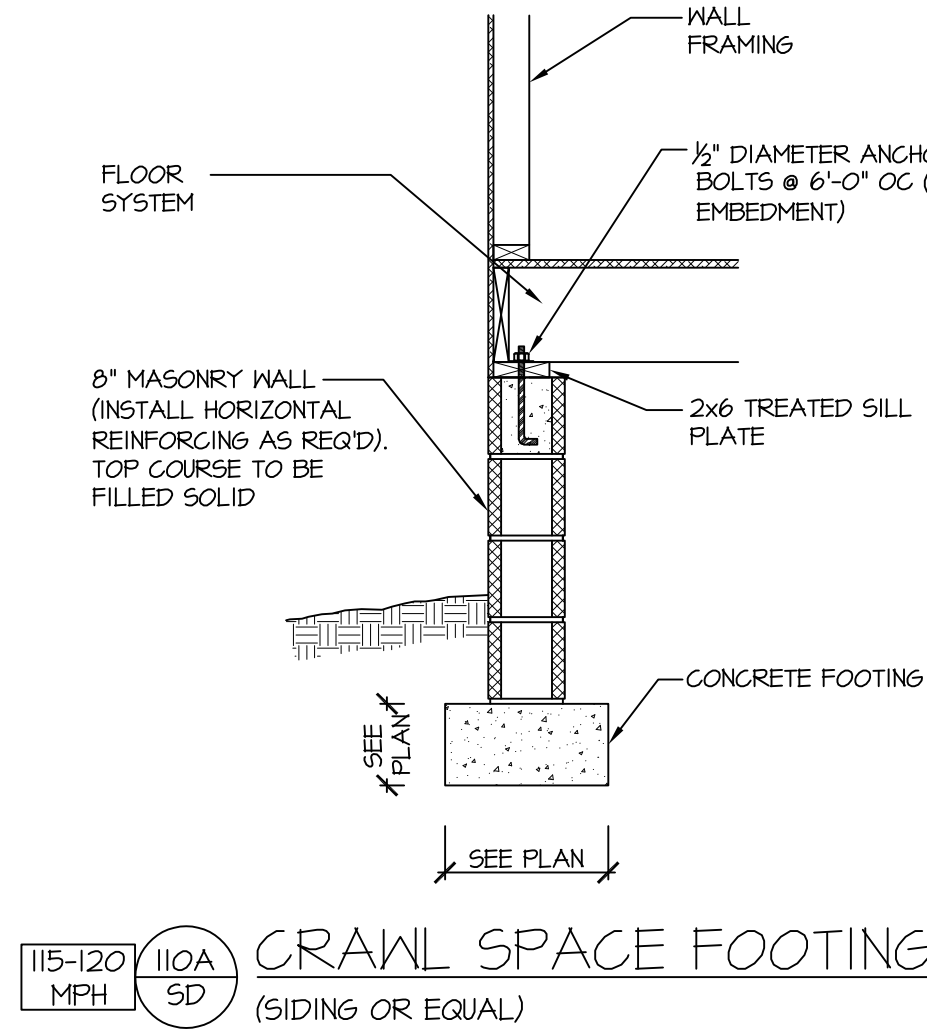
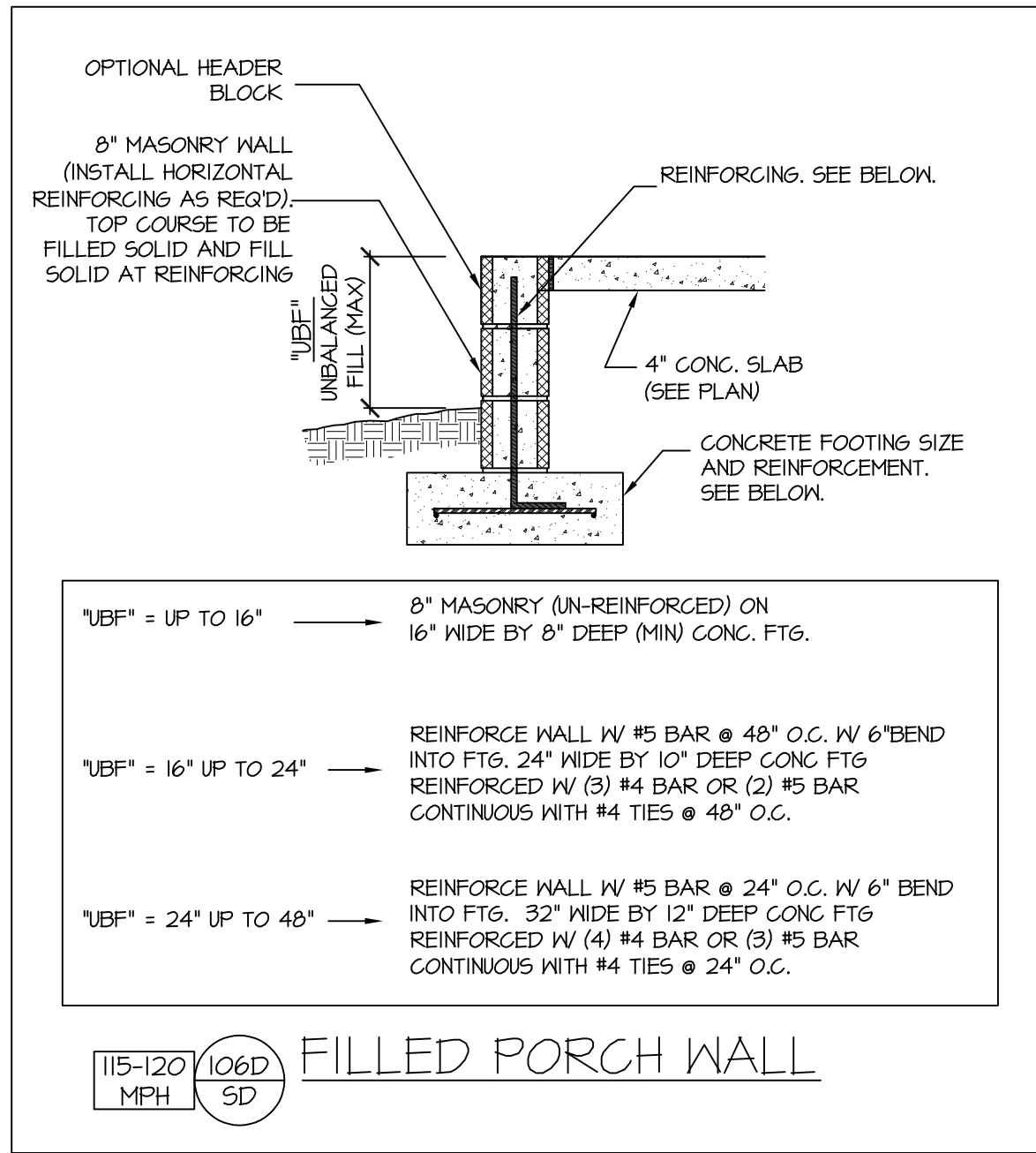

STRUCTURAL NOTES

NC (2018 NCR): Wind: 115-120 mph

- ENGINEER'S SEAL APPLIES ONLY TO STRUCTURAL COMPONENTS INCLUDING ROOF RAFTERS, HIPs, VALLEYS, RIDGES, FLOORS, WALLS, BEAMS AND HEADERS, COLUMNS, CANTILEVERS, OFFSET LOAD BEARING WALLS, PIER & GIRDER SYSTEM, FOOTING, AND PILING SYSTEM. ENGINEER'S SEAL DOES NOT CERTIFY DIMENSIONAL ACCURACY OR ARCHITECTURAL LAYOUT INCLUDING ROOF SYSTEM. ALL REQUIREMENTS FOR PROFESSIONAL CERTIFICATION SHALL BE PROVIDED BY THE APPROPRIATE PROFESSIONAL. SOUTHERN ENGINEERS, P.A. CERTIFIES ONLY THE STRUCTURAL COMPONENTS AS SPECIFICALLY STATED.
- ALL CONSTRUCTION SHALL CONFORM TO THE LATEST REQUIREMENTS OF THE 2018 NC RESIDENTIAL CODE, PLUS ALL LOCAL CODES AND REGULATIONS. THE STRUCTURAL ENGINEER IS NOT RESPONSIBLE FOR, AND WILL NOT HAVE CONTROL OF, CONSTRUCTION MEANS, METHODS, TECHNIQUES, SEQUENCES OR PROCEDURES, OR FOR SAFETY PRECAUTIONS AND PROGRAMS IN CONNECTION WITH THE CONSTRUCTION WORK. NOR WILL THE ENGINEER BE RESPONSIBLE FOR THE CONTRACTOR'S FAILURE TO CARRY OUT THE CONSTRUCTION WORK IN ACCORDANCE WITH THE CONTRACT DOCUMENTS. "CONSTRUCTION REVIEW" SERVICES ARE NOT PART OF OUR CONTRACT. ALL MEMBERS SHALL BE FRAMED ANCHORED, TIED AND BRACED IN ACCORDANCE WITH GOOD CONSTRUCTION PRACTICE AND THE BUILDING CODE.
- DESIGN LOADS (LISTED AS: LIVE LOAD, DEAD LOAD, DEFLECTION)
 - ROOMS OTHER THAN SLEEPING ROOMS: (40 PSF, 10 PSF, L/360)
 - SLEEPING ROOMS: (30 PSF, 10 PSF, L/360)
 - ATTIC WITH PERMANENT STAIR: (40 PSF, 10 PSF, L/360)
 - ATTIC WITHOUT PERMANENT STAIR: (20 PSF, 10 PSF, L/360)
 - ATTIC WITHOUT STORAGE: (10 PSF, 10 PSF, L/240)
 - STAIRS: (40 PSF, 10 PSF, L/360)
 - DECKS AND EXTERIOR BALCONIES: (40 PSF, 10 PSF, L/360)
 - PASSENGER VEHICLE GARAGES: (50 PSF, 10 PSF, L/360)
 - SNOW: (20 PSF)
- WALLS SHALL BE BRACED BY SHEATHING WALLS ON ALL STORIES WITH WOOD STRUCTURAL PANELS. SEE FRAMING NOTES FOR THICKNESS AND NAILING REQUIREMENTS.
- SEE APPENDIX M (DCA6) FOR EXTERIOR DECK REQUIREMENTS INCLUDING ATTACHMENTS FOR LATERAL LOADS.
- CONCRETE SHALL HAVE A MINIMUM 28 DAY STRENGTH OF 3000 PSI AND A MAXIMUM SLUMP OF 5 INCHES UNLESS NOTED OTHERWISE (NO). AIR ENTRAINED PER TABLE 402.2. ALL CONCRETE SHALL BE PROPORTIONED, MIXED, HANDLED, SAMPLED, TESTED, AND PLACED IN ACCORDANCE WITH ACI STANDARDS. ALL SAMPLES FOR PUMPING SHALL BE TAKEN FROM THE EXIT END OF THE PUMP. CONTROL JOINTS IN SLABS SHALL BE SPACED ON A GRID OF +30 TIMES THE DEPTH (D). CONTROL JOINTS SHALL BE SAWCUT TO A DEPTH OF 1/2". (I.E. 4" CONCRETE SLABS SHALL HAVE 1/2" DEEP CONTROL JOINTS SAWCUT IN SLAB ON A +10'-0" x +10'-0" GRID).
- ALLOWABLE SOIL BEARING PRESSURE ASSUMED TO BE 2000 PSF. THE CONTRACTOR MUST CONTACT A GEOTECHNICAL ENGINEER AND THE STRUCTURAL ENGINEER IF UNSATISFACTORY SUBSURFACE CONDITIONS ARE ENCOUNTERED. THE SURFACE AREA ADJACENT TO THE FOUNDATION WALL SHALL BE PROVIDED WITH ADEQUATE DRAINAGE, AND SHALL BE GRADED SO AS TO DRAIN SURFACE WATER AWAY FROM FOUNDATION WALLS.
- ALL FRAMING LUMBER SHALL BE SPF #2 (Fb = 875 PSI) UNLESS NOTED OTHERWISE (UNO). ALL TREATED LUMBER SHALL BE 51P # 2. PLATE MATERIAL MAY BE 51P # 3 OR 51P #3 (Fcp/ptp) = 425 PSI - MIN.
- L.V.L. SHALL BE LAMINATED VENEER LUMBER: Fb=2600 PSI, Fv=285 PSI, E=1.4x10⁶ PSI.
P.S.L. SHALL BE PARALLEL STRAND LUMBER: Fb=2400 PSI, Fv=240 PSI, E=2.0x10⁶ PSI.
L.S.L. SHALL BE LAMINATED STRAND LUMBER: Fb=2250 PSI, Fv=400 PSI, E=1.55x10⁶ PSI. INSTALL ALL CONNECTIONS PER MANUFACTURERS INSTRUCTIONS.
- ALL ROOF TRUSS AND I-JOIST LAYOUTS SHALL BE PREPARED IN ACCORDANCE WITH THE SEALED STRUCTURAL DRAWINGS. TRUSSES AND I-JOISTS SHALL BE INSTALLED ACCORDING TO THE MANUFACTURER'S SPECIFICATIONS. ANY CHANGE IN TRUSS OR I-JOIST LAYOUT SHALL BE COORDINATED WITH SOUTHERN ENGINEERS.
- ALL STRUCTURAL STEEL SHALL BE ASTM A-36. STEEL BEAMS SHALL BE SUPPORTED AT EACH END WITH A MINIMUM BEARING LENGTH OF 3 1/2" INCHES AND FULL FLANGE WIDTH. PROVIDE SOLID BEARING FROM BEAM SUPPORT TO FOUNDATION. BEAMS SHALL BE ATTACHED TO EACH SUPPORT WITH TWO LAG SCREWS (1/2" DIAMETER x 4" LONG). LATERAL SUPPORT IS CONSIDERED ADEQUATE PROVIDING THE JOIST ARE TOE NAILED TO THE SOLE PLATE, AND SOLE PLATE IS NAILED OR BOLTED TO THE BEAM FLANGE @ 48" O.C. ALL STEEL TUBING SHALL BE ASTM A500.
- REBAR SHALL BE DEFORMED STEEL, ASTM615, GRADE 60. LAP ALL REBAR SPLICES 30 BAR DIAMETERS.
- FLITCH BEAMS SHALL BE BOLTED TOGETHER USING (2) ROWS OF 1/2" DIAMETER BOLTS (ASTM A325) WITH WASHERS PLACED UNDER THE THREADED END OF BOLT. BOLTS SHALL BE SPACED AT 24" O.C. (MAX) AND STAGGERED AT THE TOP AND BOTTOM OF BEAM (2" EDGE DISTANCE), WITH 2 BOLTS LOCATED AT 6" FROM EACH END.
- BRICK LINTELS (WHEN REQUIRED) SHALL BE 3 1/2"x3 1/2"x1/4" STEEL ANGLE FOR UP TO 6'-0" SPAN AND 6"x4"x5/16" STEEL ANGLE WITH 6" LEG VERTICAL FOR SPANS UP TO 9'-0". SEE PLANS FOR SPANS OVER 9'-0". SEE ALSO SECTION RT03.B.3 LINTELS.
- METAL CONNECTORS REFERENCED ON PLANS CORRESPOND TO SIMPSON STRONG-TIE BRAND. CONNECTORS OF EQUAL OR BETTER CAPACITY ARE ACCEPTABLE. CORROSION RESISTANCE PER CODE AND AS RECOMMENDED BY MANUFACTURER.

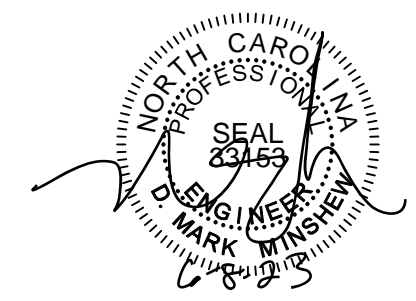

PROJECT #
23-1414

Engineers seal applies only to structural components on this document.
Seal does not include construction means, methods, techniques, sequences, procedures or safety precautions.
Any deviations or discrepancies on plans are to be brought to the immediate attention of Southern Engineers, P.A. Failure to do so will void Southern Engineers' liability.
Seal is valid for projects permitted one year from date of seal.
Use of these plans constitutes approval of terms & conditions as defined in the customer agreement.

Southern Engineers, P.A.
3716 Benson Drive, Raleigh, NC 27609
Phone: (919) 878-1617
License: C-4772
www.southernengineers.com

K&A HOME
DESIGN, INC.

Lot 43, Cotton Farm
Ryleigh - Garage Left
PORTER BUILT HOMES

SD