

MAGNOLIA

ELEVATION B

PRINCE PLACE LOT 44



INCLUDED OPTIONS:

- 1st FLOOR**
- SCREENED PORCH**
- GOURMET KITCHEN**
- FIREPLACE W BUILT-INS**
- FIXED WINDOWS @ FAMILY ROOM**
- FLOOR RECEPTACLE @ FAM RM**
- FRENCH DOORS @ STUDY**
- BOX OAK STAIRS**
- OPEN STAIR RAIL**
- TRAY @ DINING**
- TRAY @ OWNERS**
- OWNERS SPA SHOWER**
- TUB W/ CEILING HT. TILE @ BATH 2**
- SECOND SINK @ BATH 2**
- MUD ROOM BENCH**
- 2nd FLOOR**
- BONUS ROOM**
- BEDROOM 4 W/ BATH**
- UNFINISHED STORAGE**

BASE HOUSE SQUARE FOOTAGE CALCULATIONS						TOTAL UNDER ROOF
ELEVATION	1st FLOOR	TOTAL FIN.	FRONT PORCH	REAR PORCH	GARAGE	
ELEV. B	2,524 s.f.	2,524 s.f.	159 s.f.	300 s.f.	396 s.f.	3,379 s.f.
OPTIONS SQUARE FOOTAGE CALCULATIONS						
OPTIONS:						
BONUS ROOM W/ BEDROOM			+927 s.f.	UNFINISHED STORAGE		+124 s.f.

CRAWL VENTING
 2524 SQ FT OF FOUNDATION TO BE VENTED
 150 SQ FT / 1 SQ FT = 16.83 SQ FT VENTILATION
 VENTS 128 SQ IN = (0.8889 SQ FT)
 CRAWL VENT
 16.827 SQ FT = 60.6 VENTS REQUIRED
 0.2778 SQ FT
 ACTUAL CRAWL VENTS PROVIDED 61
 NOTE: WHERE AN APPROVED VAPER BARRIER IS
 INSTALLED OVER GROUND SURFACE THE REQUIRED
 VENTILATION MAY BE REDUCED BY 50%

REVISION NUMBER

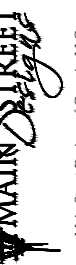

Main Street Designs of Georgia, LLC
 www.MainStreetDesignsLLC.com
 3150 Royal Blvd, South, Suite 135
 Alpharetta, GA 30022
 O. (404) 996-5722



1/8" = 1'-0"

RELEASE DATE
06-15-2021
PROJECT NUMBER
OPTION NO.

MODEL
MAGNOLIA
DRAWING TITLE
COVER SHEET
OPTION DESCRIPTION

SHEET NO.
CS-1.0

NOTE; PROPANE TANK TO BE SET 5' FROM VENTS 10' FROM IGNITION

PROPANE TANK

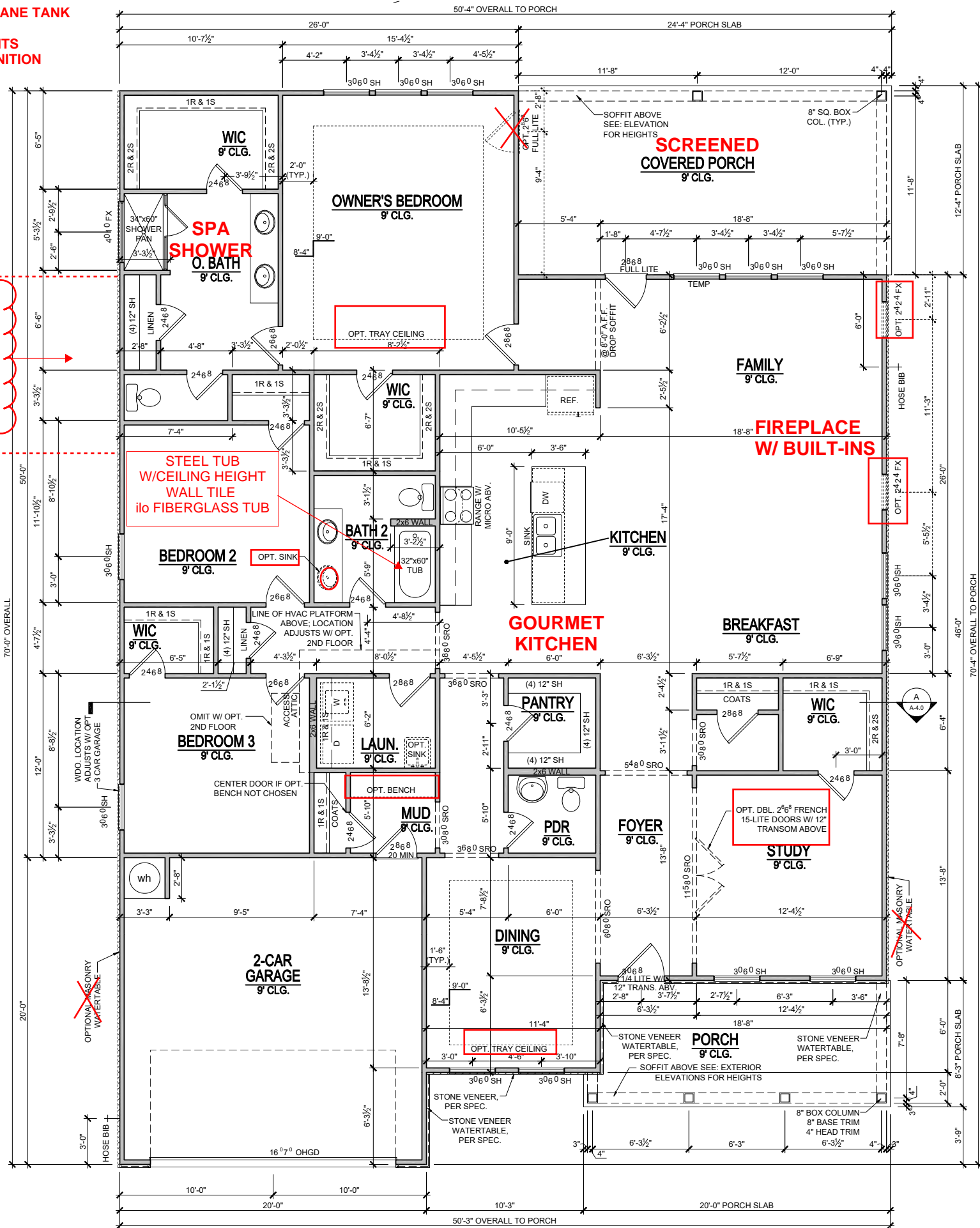

1st FLOOR PLAN - ELEVATION B
SCALE: 1/8"=1'-0" (11"x17" SHEET SIZE)
SCALE: 1/4"=1'-0" (22"x34" SHEET SIZE)

SEE PAGE 0-5.0 FOR OPTIONS:
SCREENED PORCH
SPA SHOWER
FIREPLACE W/
BUILT-INS
GOURMET KITCHEN
BENCH DETAIL

PRINCE PLACE LOT 44

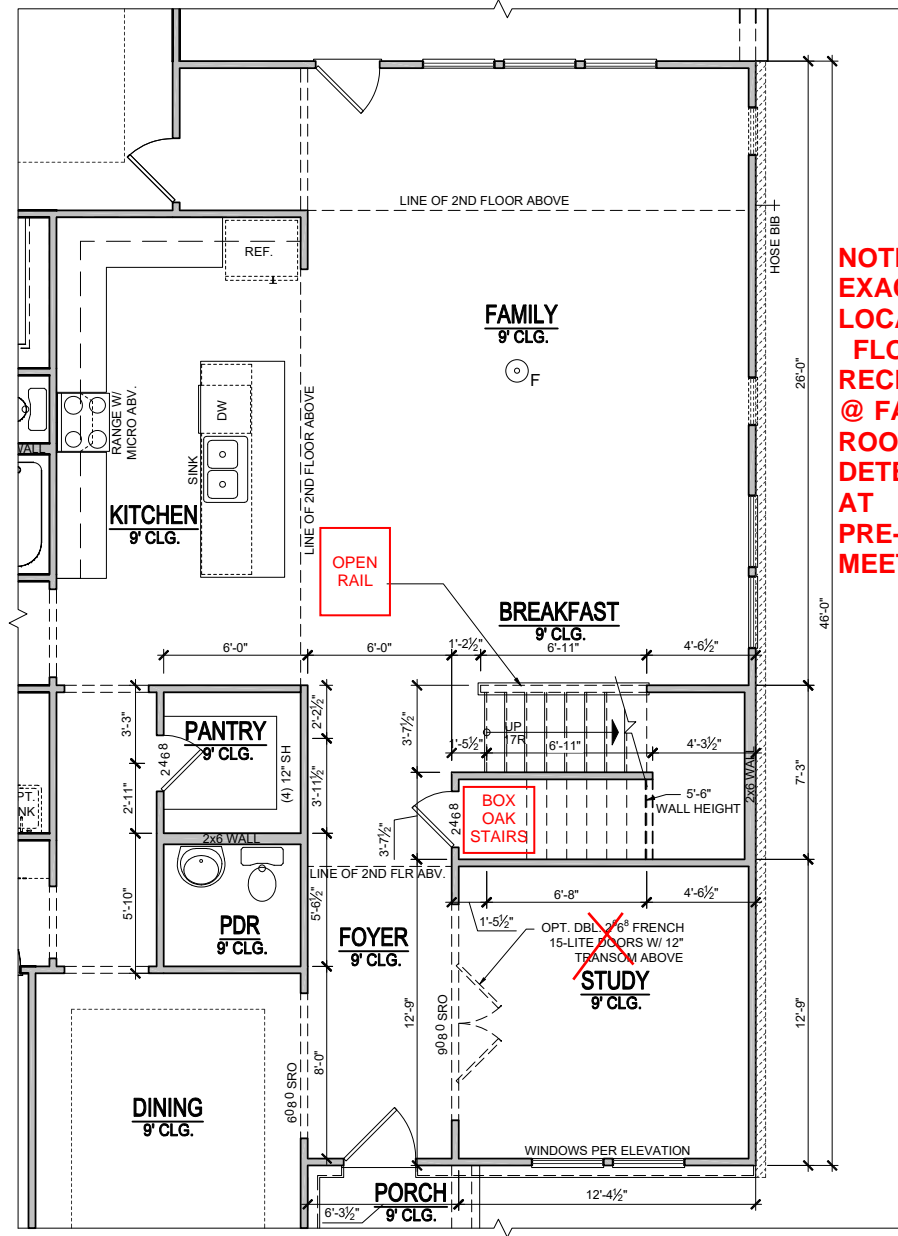

STAIRS AT OPT. BONUS ROOM 1ST FLOOR PLAN
SCALE: 1/8"=1'-0" (11"x17" SHEET SIZE)
SCALE: 1/4"=1'-0" (22"x34" SHEET SIZE)

NOTE: EXACT LOCATION OF FLOOR RECEPTACLE @ FAMILY ROOM TO BE DETERMINED AT PRE-CON MEETING

REVISION NUMBER	
MAIN STREET DESIGN	Main Street Designs of Georgia, LLC www.MainStreetDesigns.com 3050 Royal Blvd. South, Suite 135 Alpharetta, GA 30022 O. (404) 996-5722
DAVIDSON HOMES	Your Community Builder
RELEASE DATE	06-15-2021
PROJECT NUMBER	
OPTION NO.	
MODEL	MAGNOLIA
DRAWING TITLE	FIRST FLOOR PLAN
OPTION DESCRIPTION	ELEVATION - B
SHEET NO.	A-1.0B

PRINCE PLACE LOT 44

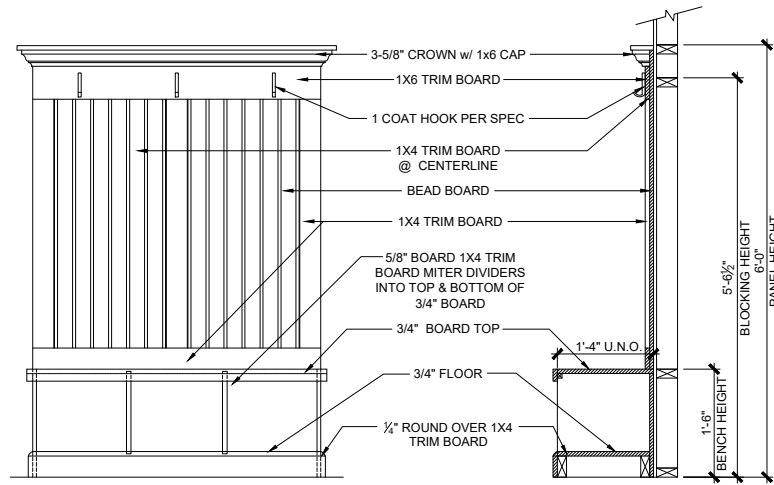

OPT. BENCH DETAIL

SCALE: 3/8"=1'-0" (11"x17" SHEET SIZE)
SCALE: 3/4"=1'-0" (22"x34" SHEET SIZE)

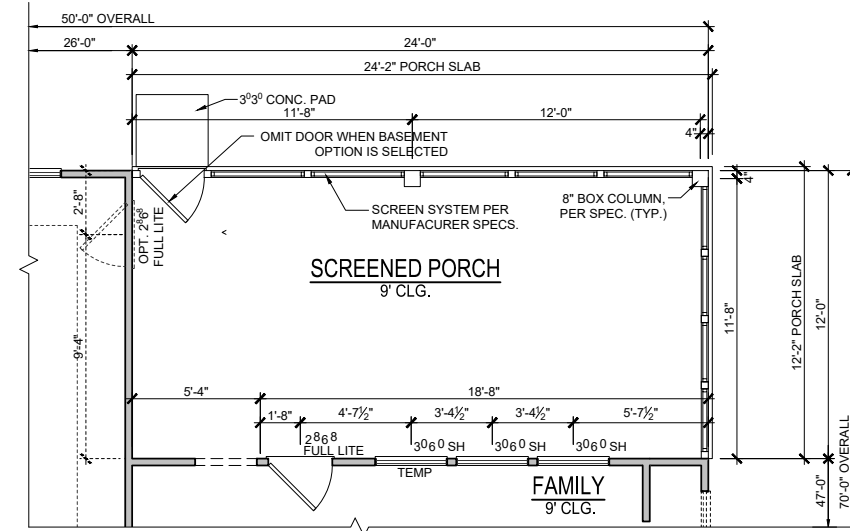

**1st FLOOR PLAN
OPT. SCREENED PORCH**

SCALE: 1/8"=1'-0" (11"x17" SHEET SIZE)
SCALE: 1/4"=1'-0" (22"x34" SHEET SIZE)

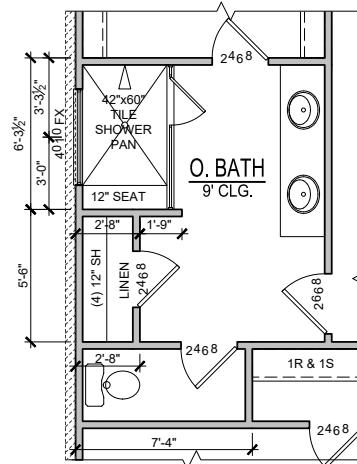

OPT. SPA SHOWER

SCALE: 1/8"=1'-0" (11"x17" SHEET SIZE)
SCALE: 1/4"=1'-0" (22"x34" SHEET SIZE)

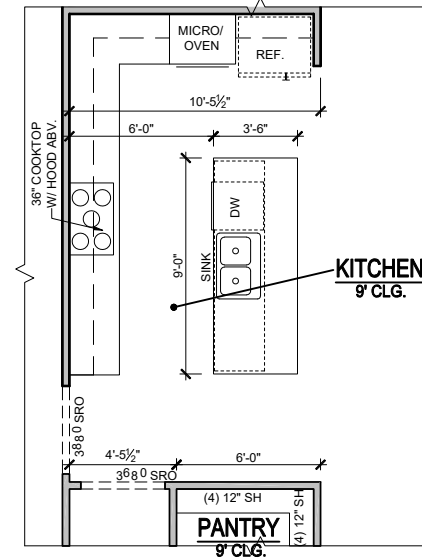

OPT. GOURMET KITCHEN

SCALE: 1/8"=1'-0" (11"x17" SHEET SIZE)
SCALE: 1/4"=1'-0" (22"x34" SHEET SIZE)

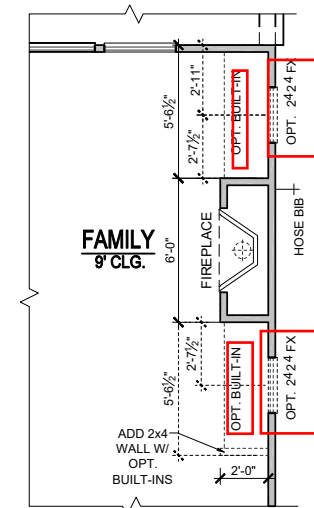

OPT. FIREPLACE

SCALE: 1/8"=1'-0" (11"x17" SHEET SIZE)
SCALE: 1/4"=1'-0" (22"x34" SHEET SIZE)

REVISION NUMBER

MAIN STREET
Designs

Main Street Designs of Georgia, LLC
www.MainStreetDesignsLLC.com
3050 Royal Blvd. South, Suite 135
Alpharetta, GA 30022
O. (404) 996-5722

DAVIDSON
HOMES
Your Community Builder

1/8"=1'-0"

RELEASE DATE	06-15-2021
PROJECT NUMBER	-----
OPTION NO.	-----

MODEL	MAGNOLIA
DRAWING TITLE	PLAN OPTIONS
OPTION DESCRIPTION	-----

SHEET NO.
O-5.0

PRINCE PLACE LOT 44

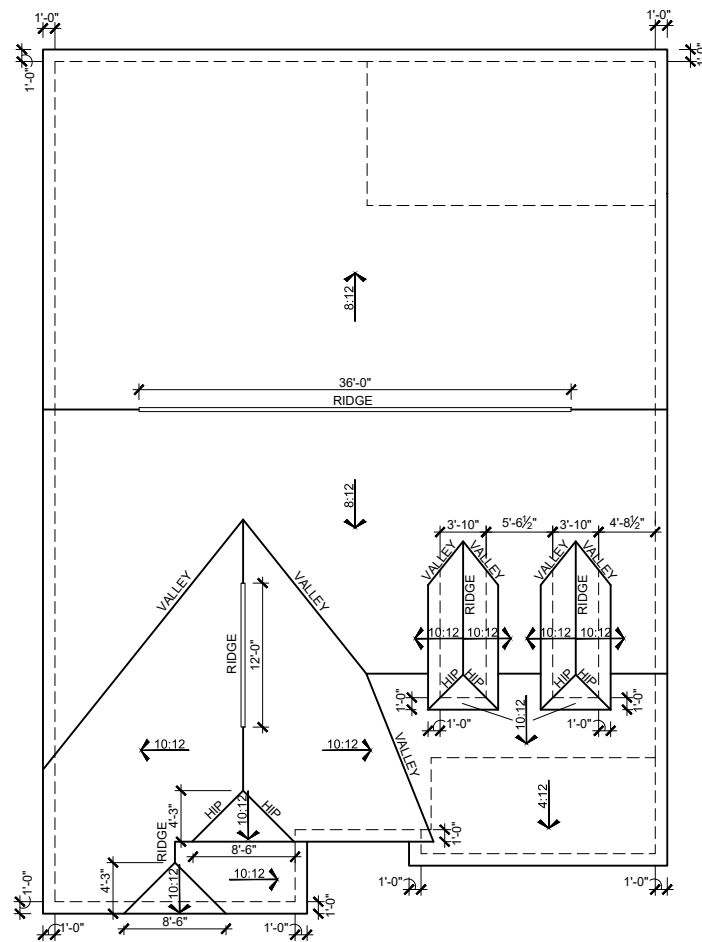

ELEVATION -B- ROOF PLAN

SCALE: 1/16"=1'-0" (11"X17" SHEET SIZE)
 SCALE: 1/8"=1'-0" (22"X34" SHEET SIZE)

ATTIC VENT CALCULATIONS

NOTES:

- GENERAL CONTRACTOR SHALL VERIFY THE NET FREE VENTILATION OF THE VENT PRODUCT SELECTED BY OWNER. VERIFY WITH MANUFACTURER OF HIGH AND LOW VENTS TO BE USED FOR MINIMUM CALCULATED VENTS REQUIRED. THE REQUIRED VENTILATION SHALL BE MAINTAINED. PROVIDE INSULATION STOP SUCH THAT INSULATION DOES NOT OBSTRUCT FREE AIR MOVEMENT AS REQUIRED BY THE BUILDING OFFICIAL. ALL OVERLAP FRAMED ROOF AREAS SHALL HAVE
- OPENINGS BETWEEN THE ADJACENT ATTICS IN THE ROOF SHEATHING (AS ALLOWED BY THE STRUCTURAL ENGINEER) TO ALLOW PASSAGE AND ATTIC VENTILATION BETWEEN THE TWO OR ISOLATED ATTIC SPACES SHALL BE VENTED INDEPENDENTLY TO CBC REQUIREMENTS.
- PER DEVELOPER, AT ALL CANTILEVERED FLOORS, CANTILEVERED ARCHITECTURAL POP-OUTS, AND ANY DOUBLE FRAMING PROJECTIONS THAT ARE SEPARATED FROM THE VENTING CALCULATIONS SHOWN ABOVE, PROVIDE A CONTINUOUS 2" CORROSION RESISTANT SOFFIT VENT AT UNDERSIDE OF FRAMED ELEMENT.
- ALL ROOF DRAINAGE SHALL BE PIPED TO STREET OR APPROVED DRAINAGE FACILITY.
- DASHED LINES INDICATE WALL BELOW.
- LOCATE GUTTER AND DOWNSPOUTS PER BUILDER.
- PITCHED ROOFS AS NOTED.
- TRUSS MANUFACTURER SHALL SUBMIT STRUCTURAL CALCS AND SHOP DRAWINGS TO THE BUILDER'S GENERAL CONTRACTOR AND BUILDING DEPARTMENT FOR REVIEW PRIOR TO FABRICATIONS.
- ALL PLUMBING VENTS SHALL BE COMBINED INTO A MINIMUM AMOUNT OF ROOF PENETRATIONS. ALL ROOF PENETRATIONS SHALL OCCUR TO THE REAR OF THE MAIN RIDGE

MAIN ROOF	
3359 SQ FT UNDER ROOF ATTIC	
300 SQ FT / 1 SQ FT = 11.20 SQ FT VENTILATION	
RIDGE VENTS 18 SQ IN = (.125 SQ FT)	
SOFFIT VENTS 9 SQ IN = (.0625 SQ FT)	
BOX VENTS 50 SQ IN = (.347 SQ FT)	
11.20 SQ FT x 50% = 5.598 SQ FT OF RIDGE	
11.20 SQ FT x 50% = 5.598 SQ FT OF SOFFIT	
RIDGE VENT	5.598 SQ FT = 44.8 FEET OF RIDGE VENT
SOFFIT VENT	0.125 SQ FT = 89.6 FEET OF SOFFIT VENT
SOFFIT VENT	5.598 SQ FT = 89.6 FEET OF SOFFIT VENT
SOFFIT VENT	0.0625 SQ FT
ACTUAL RIDGE VENT PROVIDED	48 FEET
ACTUAL SOFFIT VENT PROVIDED	85 FEET
NUMBER OF BOX VENTS NEEDED (REQ - ACTUAL x .347)	-1.1 COUNT (NEGATIVE = 0)

FACADE PERCENTAGES	
MATERIALS	S.F. %
SIDING	166 45
SHAKE	85 21
BOARD & BATT	0 0
HARDI BOARD	0 0
STONE VENEER	142 34
BRICK VENEER	0 0
TOTAL	413 100
MASONRY	% = 34

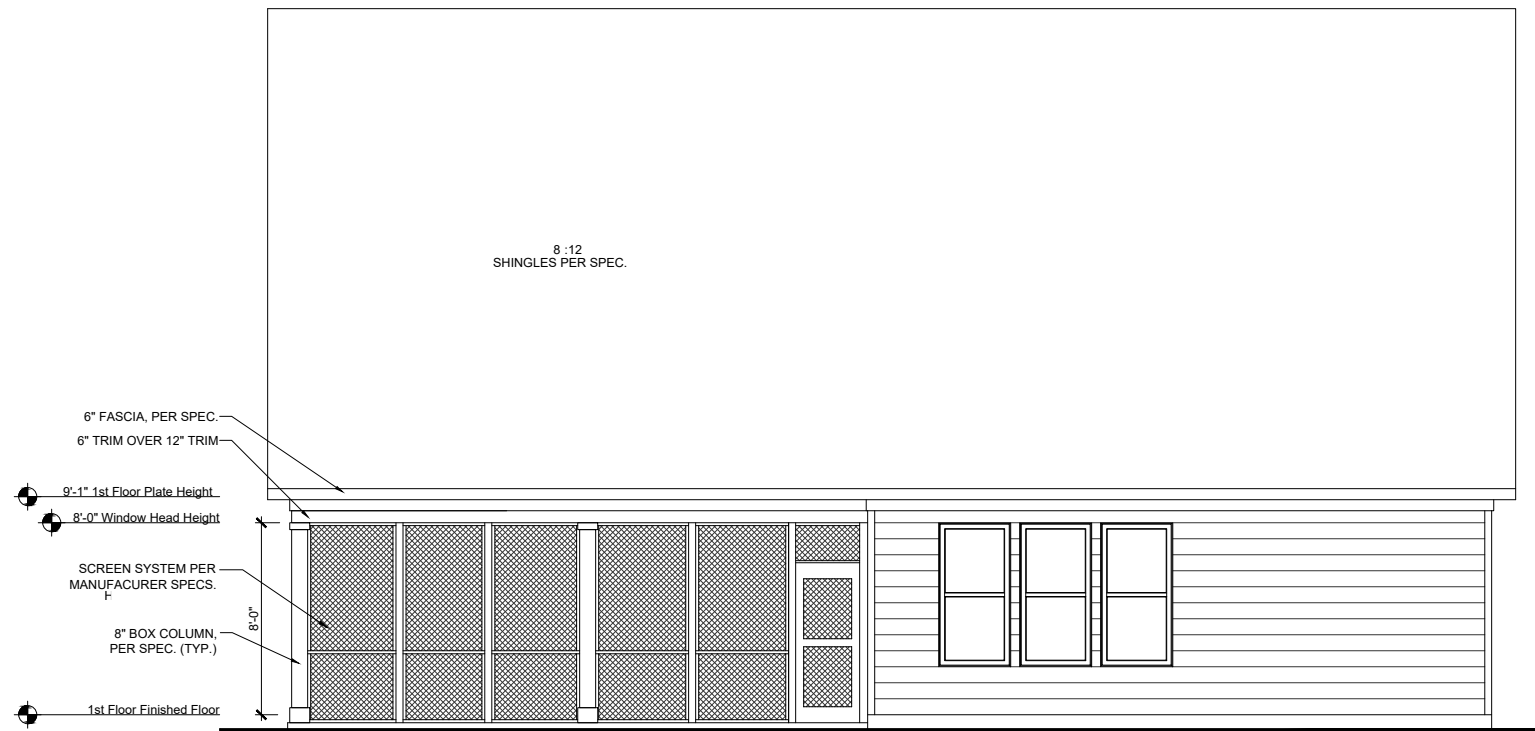

SCREENED PORCH REAR ELEVATION

SCALE: 1/8"=1'-0" (11"X17" SHEET SIZE)
 SCALE: 1/4"=1'-0" (22"X34" SHEET SIZE)

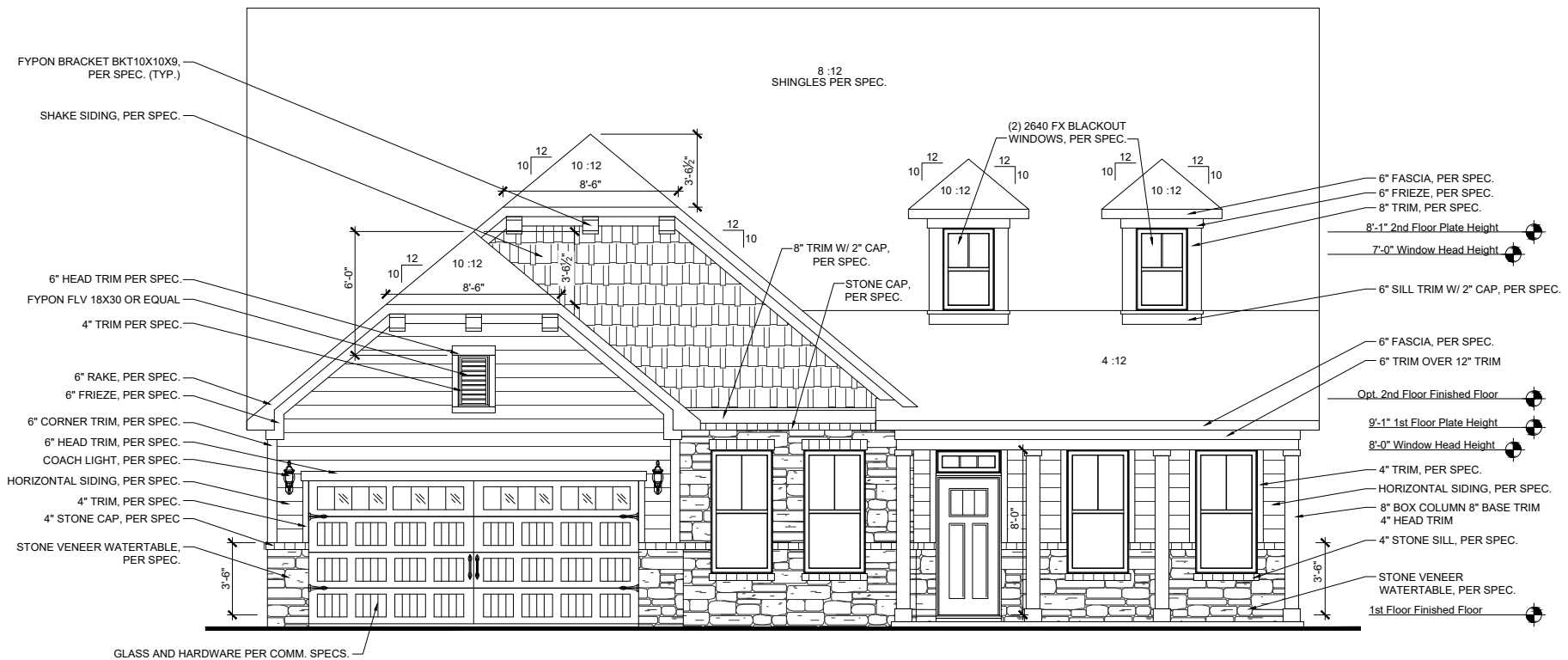

FRONT ELEVATION - 'B'

SCALE: 1/8"=1'-0" (11"X17" SHEET SIZE)
 SCALE: 1/4"=1'-0" (22"X34" SHEET SIZE)

REVISION NUMBER

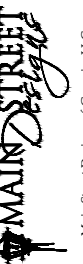

Main Street Designs of Georgia, LLC
 www.MainStreetDesignsLLC.com
 3050 Royal Blvd. South, Suite 135
 Alpharetta, GA 30009
 C. (404) 996-5722



1/8"=1'-0"

RELEASE DATE	06-15-2021
PROJECT NUMBER	
OPTION NO.	

MODEL	MAGNOLIA
DRAWING TITLE	EXT. ELEV/ ROOF PLAN
OPTION DESCRIPTION	ELEVATION - B

SHEET NO.

A-2.0B

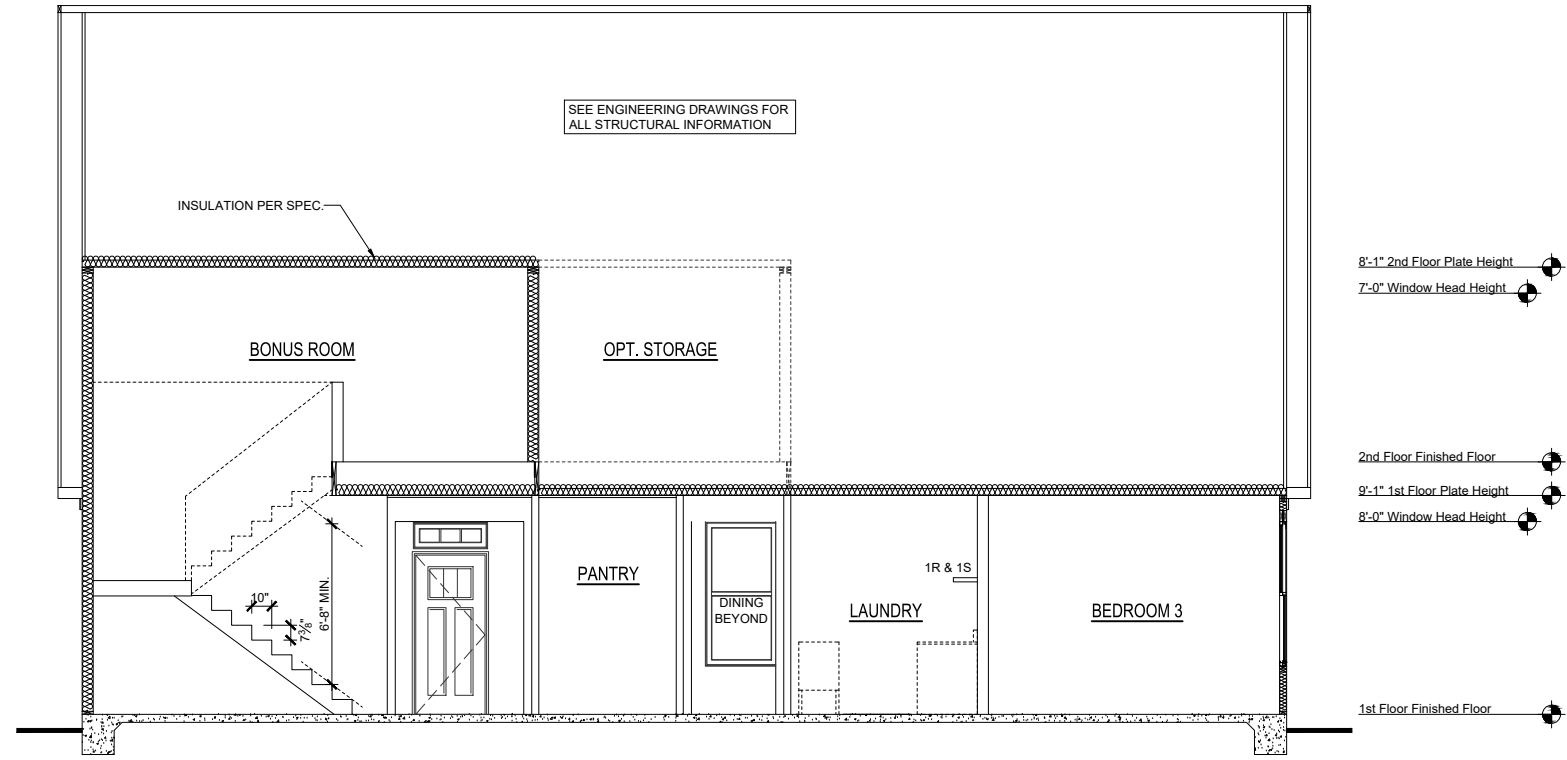

SEE ENGINEERING DRAWINGS FOR ALL STRUCTURAL INFORMATION

INSULATION PER SPEC.

BONUS ROOM

OPT. STORAGE

PANTRY

DINING BEYOND

LAUNDRY

1R & 1S

BEDROOM 3

8'-1" 2nd Floor Plate Height
 7'-0" Window Head Height
 2nd Floor Finished Floor
 9'-1" 1st Floor Plate Height
 8'-0" Window Head Height
 1st Floor Finished Floor

SECTION - A @ OPT. 2ND FLOOR BONUS ROOM

SCALE: 1/8"=1'-0" (11"x17" SHEET SIZE)
 SCALE: 1/4"=1'-0" (22"x34" SHEET SIZE)

REVISION NUMBER

MAIN STREET
Designs
 Main Street Designs of Georgia, LLC
 www.MainStreetDesigns.LLC.com
 3050 Royal Blvd. South, Suite 135
 Alpharetta, GA 30022
 O. (404) 996-5722

DAVIDSON
 HOMES

1/8" = 1'-0"

RELEASE DATE	06-15-2021
PROJECT NUMBER	-----
OPTION NO.	-----

MODEL	MAGNOLIA
DRAWING TITLE	SECTION
OPTION DESCRIPTION	OPT. BONUS ROOM & BSMT

SHEET NO.
O-5.5

PRINCE PLACE LOT 44

**NOTE; PROPANE TANK
TO BE SET
5' FROM VENTS
10' FROM IGNITION**

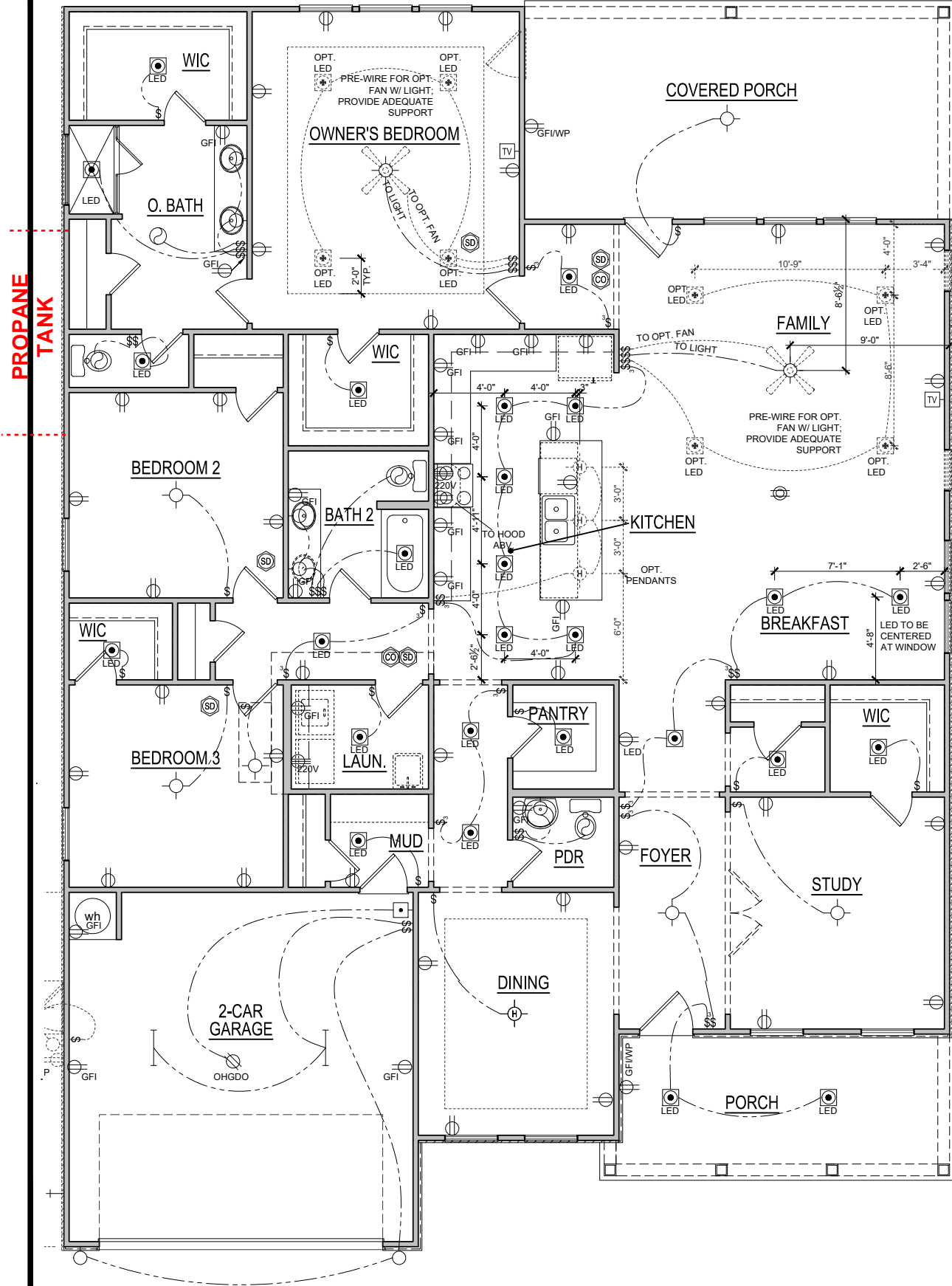

**ELEVATION - B
FIRST FLOOR ELECTRICAL PLAN**

SCALE: 1/8"=1'-0" (11"x17" SHEET SIZE)
SCALE: 1/4"=1'-0" (22"x34" SHEET SIZE)

**NOTE:
EXACT
LOCATION OF
FLOOR
RECEPTACLE
@ FAMILY
ROOM TO BE
DETERMINED
AT
PRE-CON
MEETING**

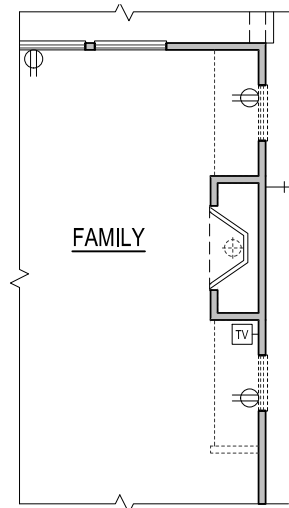

OPT. FIREPLACE

SCALE: 1/8"=1'-0" (11"x17" SHEET SIZE)
SCALE: 1/4"=1'-0" (22"x34" SHEET SIZE)

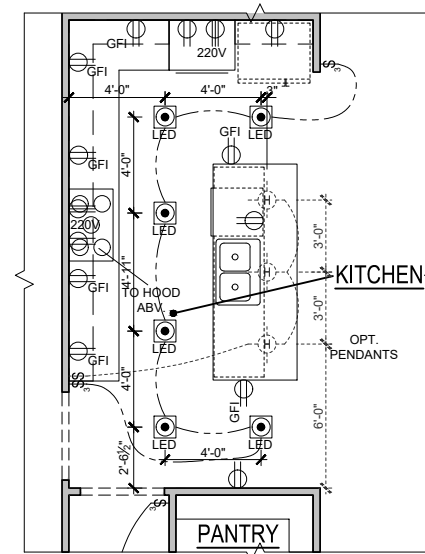

OPT. GOURMET KITCHEN

SCALE: 1/8"=1'-0" (11"x17" SHEET SIZE)
SCALE: 1/4"=1'-0" (22"x34" SHEET SIZE)

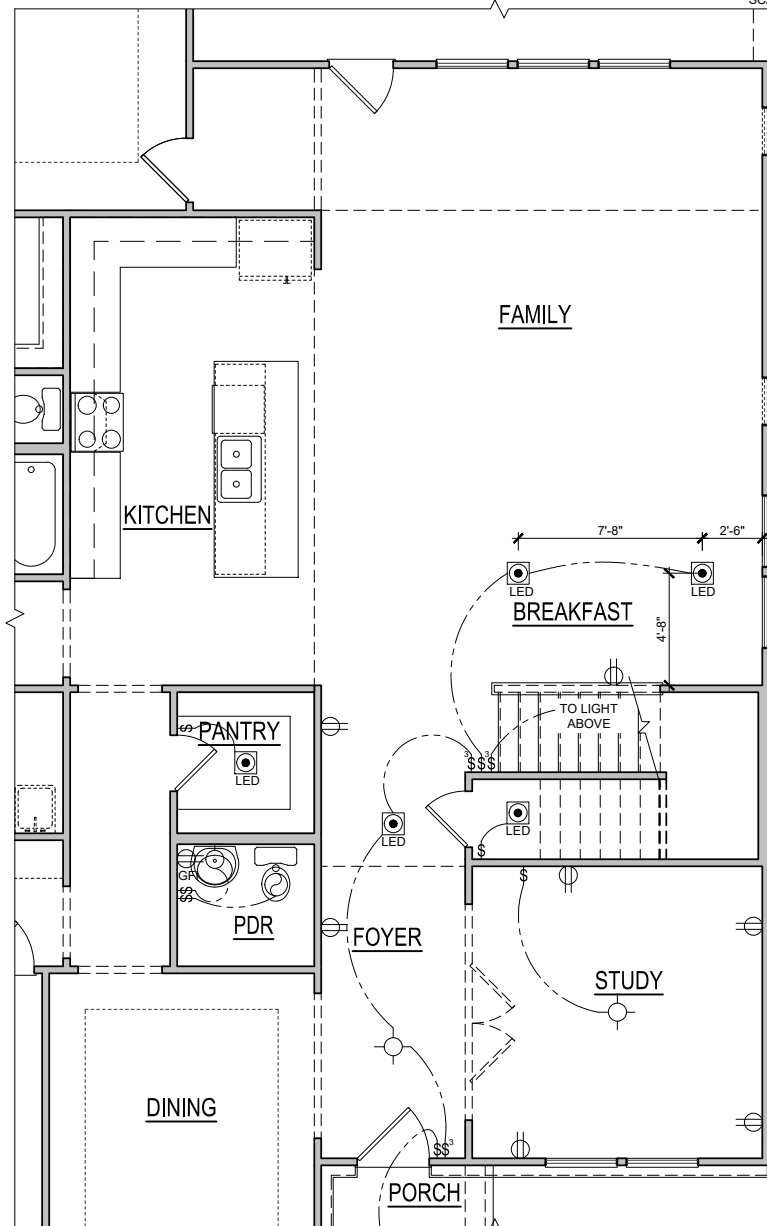

**STAIRS AT OPT. BONUS ROOM
ELECTRICAL PLAN**

SCALE: 1/8"=1'-0" (11"x17" SHEET SIZE)
SCALE: 1/4"=1'-0" (22"x34" SHEET SIZE)

ELECTRICAL KEY

- CEILING RECEP.
- DUPLEX RECEP.
- SPLIT SWITCHED RECEP.
- FLOOR RECEP.
- QUADPLEX RECEP.
- GROUND FAULT RECEP.
- WEATHER PROOF RECEP.
- 220v RECEP.
- EXHAUST FAN.
- EXHAUST FAN / LIGHT.
- EXHAUST FAN / HEAT LIGHT.
- LED CAN.
- VAPOR PROTECTED LIGHT.
- CEILING LIGHT.
- HANGING CEILING LIGHT.
- WALL LIGHT.
- WALL SCONCE LIGHT.
- SINGLE SWITCH.
- 3-WAY SWITCH.
- 4-WAY SWITCH.
- DIMMER SWITCH.
- CABLE T.V. JACK.
- BUTTON.
- PHONE JACK.
- DIRECT WIRE.
- SECURITY SYSTEM PHONE JACK.
- SMOKE DETECTOR.
- CARBON MONOXIDE DETECTOR.
- ELECTRICAL PANEL.
- DISCONNECT SWITCH.
- ELECTRIC METER.
- 1 TUBE FLUORESCENT.
- 2 TUBE FLUORESCENT.
- FLOOD LIGHT.
- CHIMES.
- CEILING FAN.
- CEILING FAN W/ LIGHT.

REVISION NUMBER

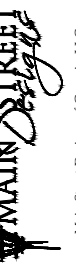

Main Street Designs of Georgia, LLC
www.MainStreetDesignsLLC.com
3050 Royal Blvd, South, Suite 135
Alpharetta, GA 30022
O. (404) 996-5722









































RELEASE DATE	06-15-2021
PROJECT NUMBER	---
OPTION NO.	---

MODEL	MAGNOLIA
DRAWING TITLE	1ST FLOOR ELCEC. PLAN
OPTION DESCRIPTION	ELEVATION - B

SHEET NO.
E-1.0B

ELECTRICAL KEY

-  CEILING RECEP.
-  DUPLEX RECEP.
-  SPLIT SWITCHED RECEP.
-  FLOOR RECEP.
-  QUADPLEX RECEP.
-  GROUND FAULT RECEP.
-  WEATHER PROOF RECEP.
-  220v RECEP.
-  EXHAUST FAN.
-  EXHAUST FAN / LIGHT.
-  EXHAUST FAN / HEAT LIGHT.
-  LED CAN.
-  LED CAN.
-  VAPOR PROTECTED LIGHT.
-  CEILING LIGHT.
-  HANGING CEILING LIGHT.
-  WALL LIGHT.
-  WALL SCONCE LIGHT.
-  SINGLE SWITCH.
-  3-WAY SWITCH.
-  4-WAY SWITCH.
-  DIMMER SWITCH.
-  CABLE T.V. JACK.
-  BUTTON.
-  PHONE JACK.
-  DIRECT WIRE.
-  SECURITY SYSTEM PHONE JACK.
-  SMOKE DETECTOR.
-  CARBON MONOXIDE DETECTOR.
-  ELECTRICAL PANEL.
-  DISCONNECT SWITCH.
-  ELECTRIC METER.
-  1 TUBE FLUORESCENT.
-  2 TUBE FLUORESCENT.
-  FLOOD LIGHT.
-  CHIMES.
-  CEILING FAN.
-  CEILING FAN.
-  CEILING FAN W/ LIGHT.

PRINCE PLACE LOT 44

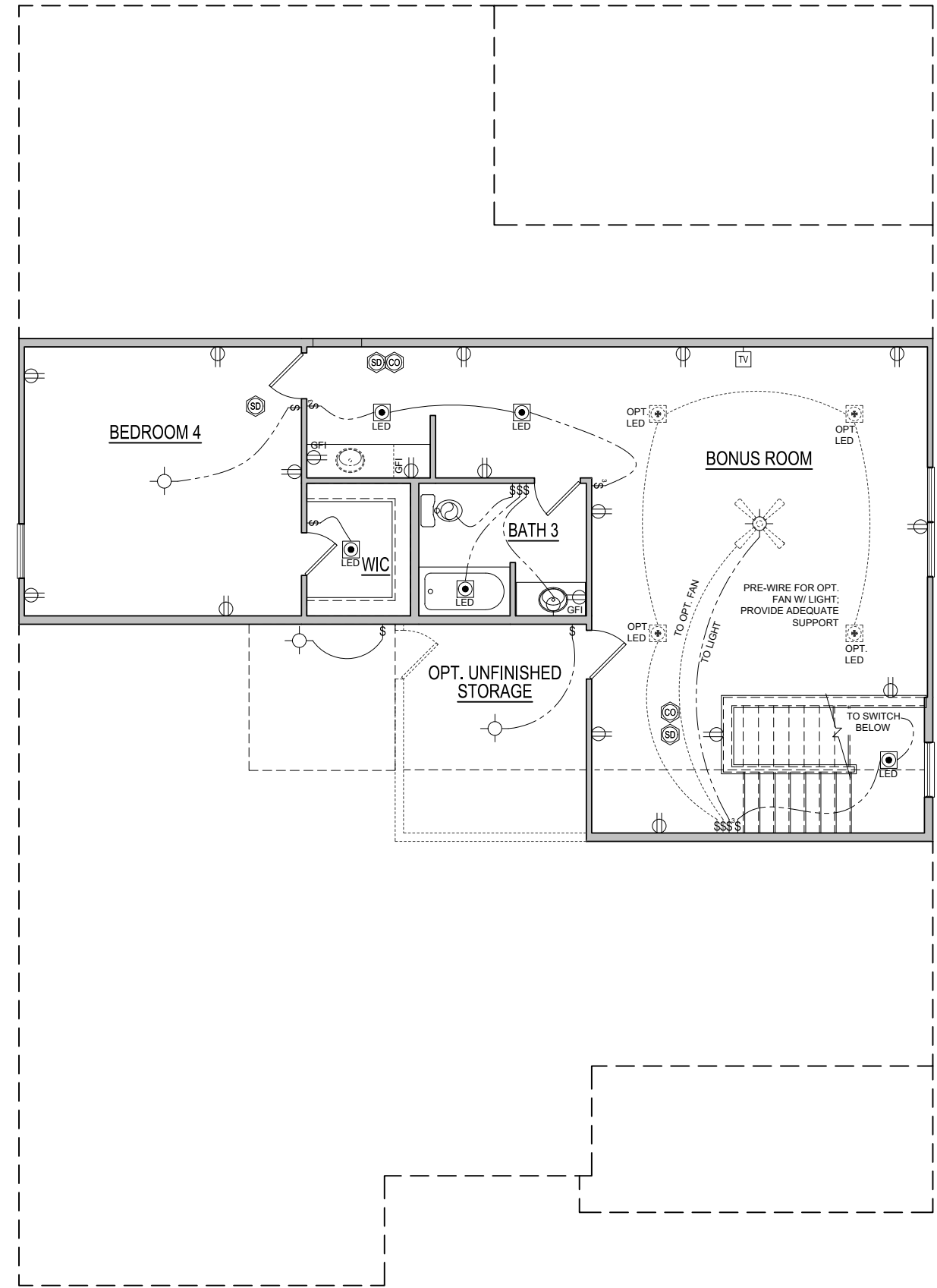

**OPT. BONUS ROOM W/ BEDROOM
2ND FLOOR ELECTRICAL**

SCALE: 1/8"=1'-0" (11"x17" SHEET SIZE)
SCALE: 1/4"=1'-0" (22"x34" SHEET SIZE)

REVISION NUMBER

MAIN STREET
Main Street Designs of Georgia, LLC
www.MainStreetDesigns.LLC.com
3050 Royal Blvd. South, Suite 135
Alpharetta, GA 30022
O. (404) 996-5722

DAVIDSON
HOMES

1/8" = 1'-0"

RELEASE DATE	06-15-2021
PROJECT NUMBER	-----
OPTION NO.	-----

MODEL	MAGNOLIA
DRAWING TITLE	PLAN OPTIONS
OPTION DESCRIPTION	2ND FLOOR BONUS W/ BED

SHEET NO.

E-1.2 B

PRINCE PLACE LOT 44

SCALE NOTE:
LARGE FORMAT PRINTS ARE TO SCALE AS NOTED.
11" x 17" PRINTS ARE ONE HALF THE NOTED SCALE

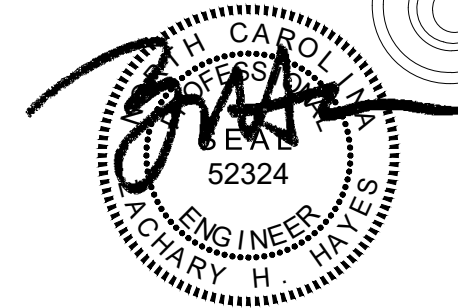

4/20/2023

J.S. THOMPSON ENGINEERING, INC.
333 EAST SIX FORKS ROAD, SUITE 180, RALEIGH, NC 27609
PHONE: (919) 7899919 FAX: (919) 7899921
N.C. LICENSE NO.: C-1733

MAGNOLIA DAVIDSON HOMES

NOTE: PROPANE TANK TO BE SET 5' FROM VENTS 10' FROM IGNITION

PROPANE TANK

NOTE: EXACT LOCATION OF FLOOR RECEPTACLE @ FAMILY ROOM TO BE DETERMINED @ PRE-CON MEETING

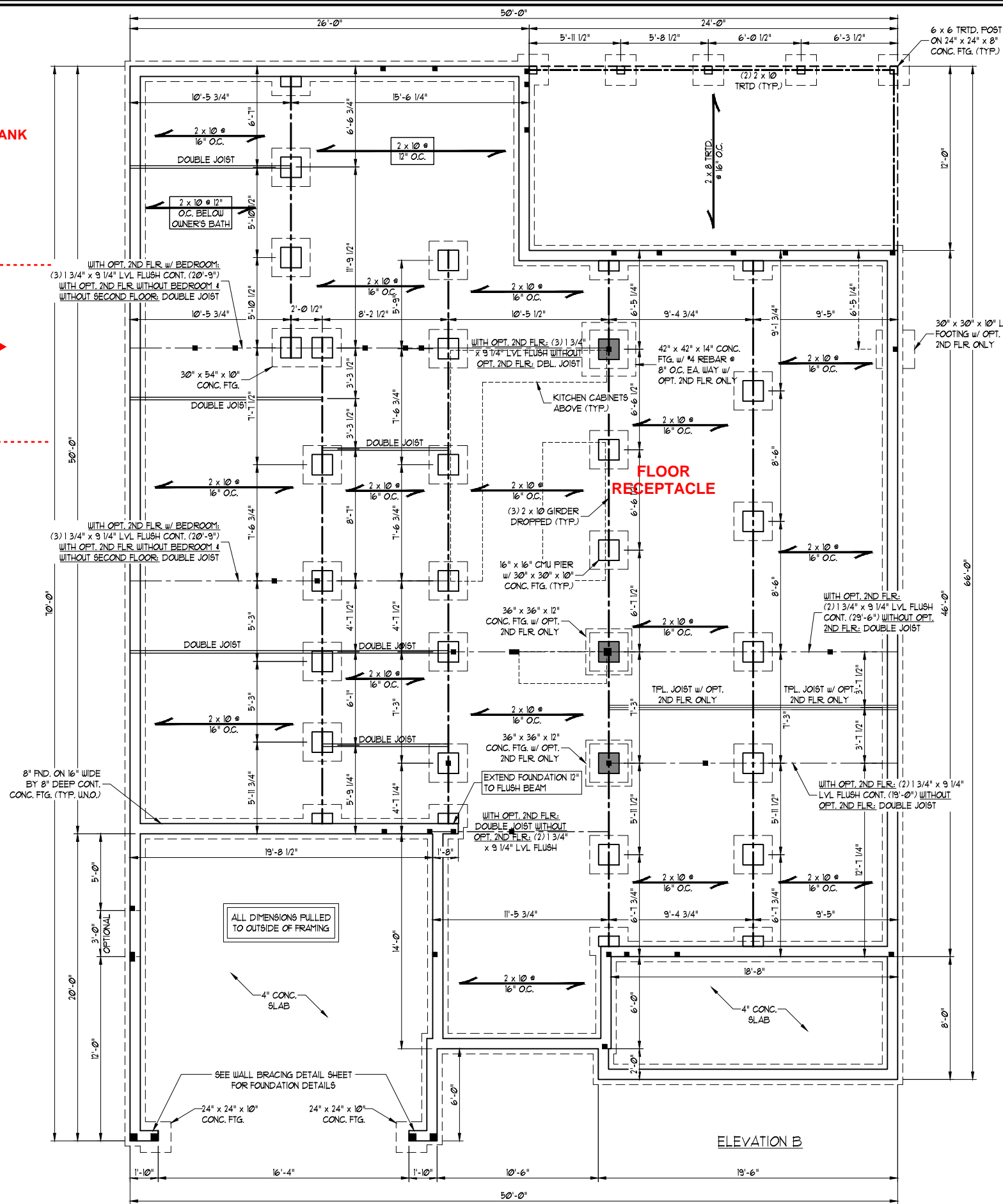

- 120 MPH ULTIMATE DESIGN WIND SPEED. NOTES FOR LESS THAN 30' MEAN ROOF HEIGHT:
- ENGINEER'S SEAL APPLIES ONLY TO STRUCTURAL COMPONENTS. ENGINEER'S SEAL DOES NOT CERTIFY DIMENSIONAL ACCURACY OR ARCHITECTURAL LAYOUT INCLUDING ROOF SYSTEMS.
 - STRUCTURAL DESIGN PER NORTH CAROLINA RESIDENTIAL CODE, 2018 EDITION.
 - INSTALL 1/2" ANCHOR BOLTS 6'-0" O.C. AND WITHIN 1'-0" FROM END OF EACH CORNER. ANCHOR BOLTS MUST EXTEND A MINIMUM OF 7" INTO MASONRY OR CONCRETE. LOCATE BOLT WITH MIDDLE THIRD OF PLATE WIDTH.
 - MEAN ROOF HEIGHT IS LESS THAN 30 FEET.
 - EXTERIOR WALLS DESIGNED FOR 120 MPH WINDS.
 - WALL CLADDING DESIGNED FOR 15.5 PSF AND -20 PSF (+/-). INDICATE POSITIVE / NEGATIVE PRESSURE (TYP).
 - ROOF CLADDING DESIGNED FOR 44.2 PSF AND -18 PSF FOR ROOF PITCHES 1/2 TO 12/12 AND 40 PSF AND -36 PSF FOR ROOF PITCHED 22.5/12 TO 1/12.
 - INSTALL 1/8" OSB SHEATHING ON ALL EXTERIOR WALLS OF ALL STORES IN ACCORDANCE WITH SECTION R602.10.3 OF THE NRC, 2018 EDITION. SEE THE WALL BRACING NOTES AND DETAILS SHEET FOR MORE INFORMATION.
 - ENERGY EFFICIENCY COMPLIANCE AND INSULATION VALUES OF THE BUILDING TO BE IN ACCORDANCE WITH CHAPTER 11 OF THE NRC, 2018 EDITION.
 - REFER TO NOTES AND DETAIL SHEETS FOR ADDITIONAL STRUCTURAL INFORMATION.

- STRUCTURAL NOTES:
- ALL FRAMING LUMBER TO BE #2 SFF OR #2 SYP (UNO). ALL TREATED LUMBER TO BE #2 SYP (UNO).
 - INSTALL DOUBLE OR TRIPLE JOIST UNDER WALLS PARALLEL TO FLOOR JOISTS WHERE NOTED ON THE PLANS.
 - SQUARES DENOTE POINT LOADS WHICH REQUIRE SOLID BLOCKING TO GIRDER OR FOUNDATION.
 - SHADED PIERS TO BE FILLED SOLID.
 - INSTALL LADDER WIRE @ 16" O.C. TO SECURE MULTIPLE W/ THE FOUNDATION WALLS TOGETHER.
 - REFER TO NOTES AND DETAIL SHEETS FOR ADDITIONAL STRUCTURAL INFORMATION.

DATE: APRIL 20, 2023
SCALE: 1/4" = 1'-0"
DRAWN BY: MAIN STREET DESIGNS
ENGINEERED BY: WFB

S-1.1d
CRAWL FOUNDATION
PLAN w/ OPT. 2 x 10 JOISTS

ELEVATION B

PRINCE PLACE LOT 44

SCALE NOTE:
LARGE FORMAT PRINTS ARE TO SCALE AS NOTED.
11" x 17" PRINTS ARE ONE HALF THE NOTED SCALE

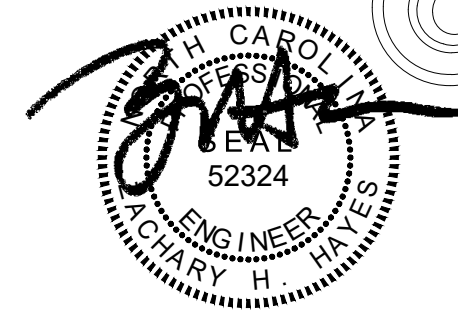

4/20/2023

J.S. THOMPSON
ENGINEERING, INC.
333 EAST SIX FORKS ROAD, SUITE 180, RALEIGH, NC 27609
PHONE: (919) 7899919 FAX: (919) 7899921
N.C. LICENSE NO.: C-1733

MAGNOLIA
DAVIDSON HOMES

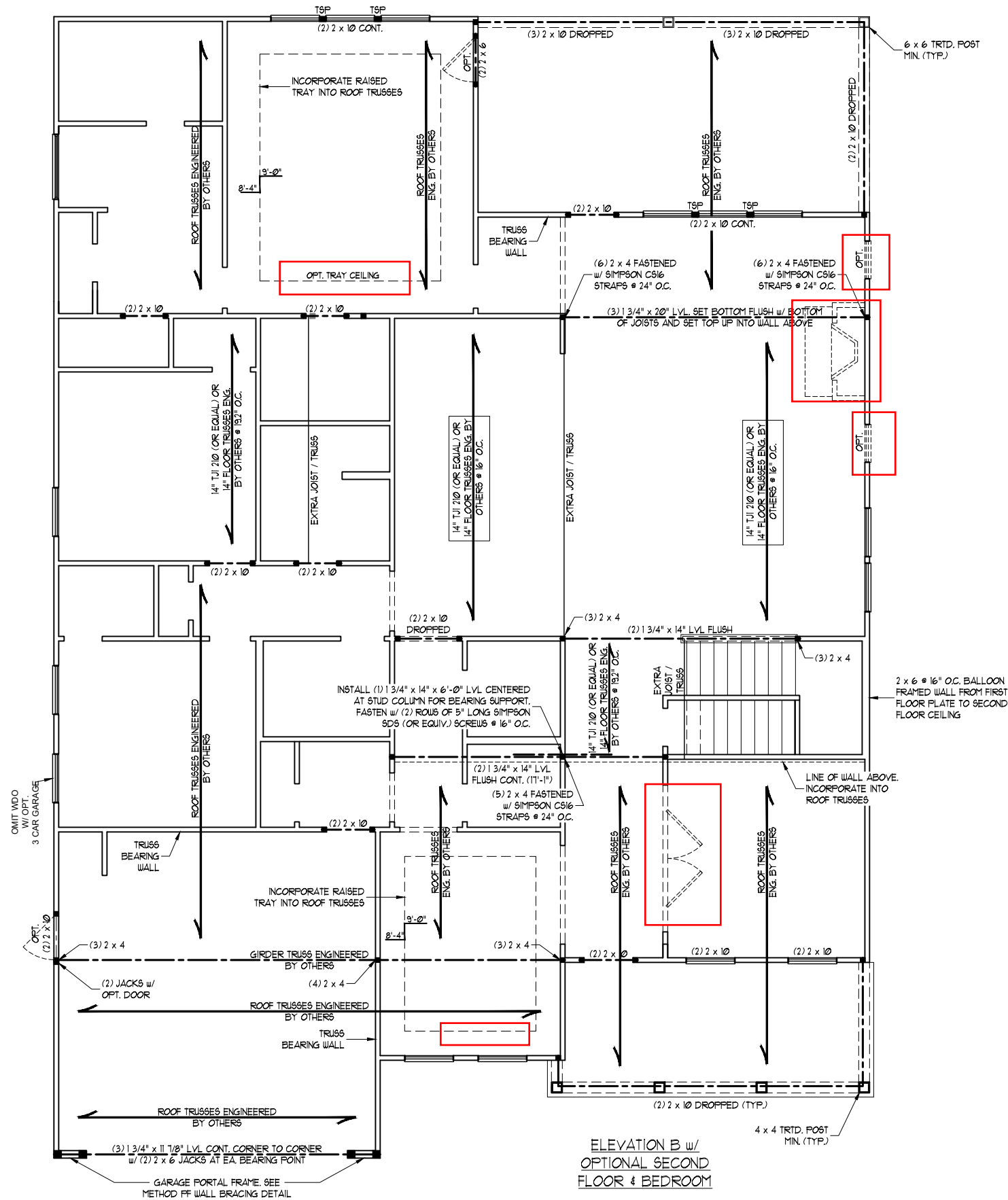

- BRACED WALL DESIGN NOTES:**
- BRACED WALL DESIGN PER SECTION R602.10.5 "WALL BRACING BY ENGINEERED DESIGN" OF THE NRCR 2018 EDITION USING BRACING MATERIALS AND METHODS LISTED IN TABLE R602.10.1 ALONG WITH ALTERNATIVE MATERIALS AND METHODS THAT COMPLY WITH ACCEPTED ENGINEERING PRACTICE. BRACED WALL DESIGN IS NOT PRESCRIPTIVE.
 - SHEATH ALL EXTERIOR WALLS w/ 7/16" OSB TO PROVIDE CS-WSP WALL BRACING THAT WILL BRACE THE STRUCTURE FOR ALL LATERAL LOADS AS REQUIRED BY THE NRCR 2018 EDITION.
 - CS-WSP REFERS TO "CONTINUOUSLY SHEATHED WOOD STRUCTURAL PANELS." CONTRACTOR IS TO INSTALL 7/16" OSB ON ALL EXTERIOR WALLS ATTACHED w/ 8d NAILS SPACED 6" O.C. ALONG PANEL EDGES AND 12" O.C. IN THE FIELD.
 - GB REFERS TO "GYPSUM BOARD." CONTRACTOR IS TO INSTALL 1/2" (MIN.) GYPSUM BOARD ON BOTH SIDES OF WALL WHERE NOTED ON THE PLANS ATTACHED WITH 1 1/4" LONG #6 SCREWS OR 1 5/8" LONG 5d COOLER NAILS SPACED 7" O.C. ALONG PANEL EDGES AND IN THE FIELD.
 - BRACED WALL DESIGN APPLIED IN WIND ZONES UP TO 130 MPH. FOR HIGH WIND ZONES, BRACED WALLS ARE TO BE CONSTRUCTED IN ACCORDANCE WITH CHAPTER 45 OF THE NRCR 2018 EDITION.
 - SEE NOTES AND DETAIL SHEETS FOR ADDITIONAL BRACED WALL INFORMATION.

TABLE R602.15
MINIMUM NUMBER OF FULL HEIGHT KING STUDS
AT EACH END OF HEADERS IN EXTERIOR WALLS

HEADER SPAN (FEET)	MINIMUM NUMBER OF FULL HEIGHT STUDS (KINGS)
UP TO 3'	1
> 3' TO 6'	2
> 6' TO 9'	3
> 9' TO 12'	4
> 12' TO 15'	5

- STRUCTURAL NOTES:**
- ALL FRAMING LUMBER TO BE SFF #2 OR SYP #2 (UNO). ALL TREATED LUMBER TO BE SYP #2 (UNO).
 - ALL LOAD BEARING HEADERS TO BE (2) 2 x 6 SFF #2 OR SYP #2 (KILN DRIED) (UNO).
 - INSTALL AN EXTRA JOIST UNDER WALLS PARALLEL TO FLOOR JOISTS WHERE NOTED ON THE PLANS.
 - WINDOW AND DOOR HEADERS TO BE SUPPORTED w/ (1) JACK STUD AND (1) KING STUD EA. END (UNO). SEE TABLE R602.15 FOR ADDITIONAL KING STUD REQUIREMENTS.
 - SQUARES DENOTE POINT LOADS WHICH REQUIRE SOLID BLOCKING TO GIRDER OR FOUNDATION. ALL SQUARES TO BE (2) STUDS (UNO).
 - ALL 4 x 4 POSTS SHALL BE ANCHORED TO SLABS w/ SIMPSON ABU44 POST BASES (OR EQUAL) AND 6 x 6 POSTS w/ ABU66 POST BASES (OR EQUAL) (UNO). ALL 4 x 4 AND 6 x 6 POSTS TO BE INSTALLED WITH 100 LB CAPACITY UPLIFT CONNECTORS AT TOP (UNO).
 - FOR FIBERGLASS, ALUMINUM, OR COLUMN ENG. BY OTHERS, SECURE TO SLAB w/ (2) METAL ANGLES USING 2" CONC. SCREWS. FASTEN ANGLES TO COLUMNS w/ 1/4" THROUGH BOLTS w/ NUTS AND WASHERS. LOCATE ANGLES ON OPPOSITE SIDES OF COLUMN. THROUGH BOLTS MUST BE INSTALLED PRIOR TO SETTING COLUMN. REFER TO NOTES AND DETAIL SHEETS FOR ADDITIONAL STRUCTURAL INFORMATION.

TSP INDICATES TRIPLE STUD POCKET BETWEEN WINDOW UNITS.

DATE: APRIL 20, 2023
SCALE: 1/4" = 1'-0"
DRAWN BY: MAIN STREET DESIGNS
ENGINEERED BY: WFB

S-3f
SECOND FLOOR
FRAMING PLAN

PRINCE PLACE LOT 44

SCALE NOTE:
LARGE FORMAT PRINTS ARE TO SCALE AS NOTED.
11" x 17" PRINTS ARE ONE HALF THE NOTED SCALE

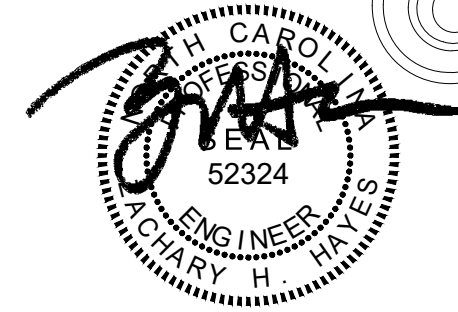

4/20/2023

J.S. THOMPSON ENGINEERING, INC
333 EAST SIX FORKS ROAD, SUITE 180, RALEIGH, NC 27609
PHONE: (919) 7899919 FAX: (919) 7899921
N.C. LICENSE NO.: C1733

MAGNOLIA DAVIDSON HOMES

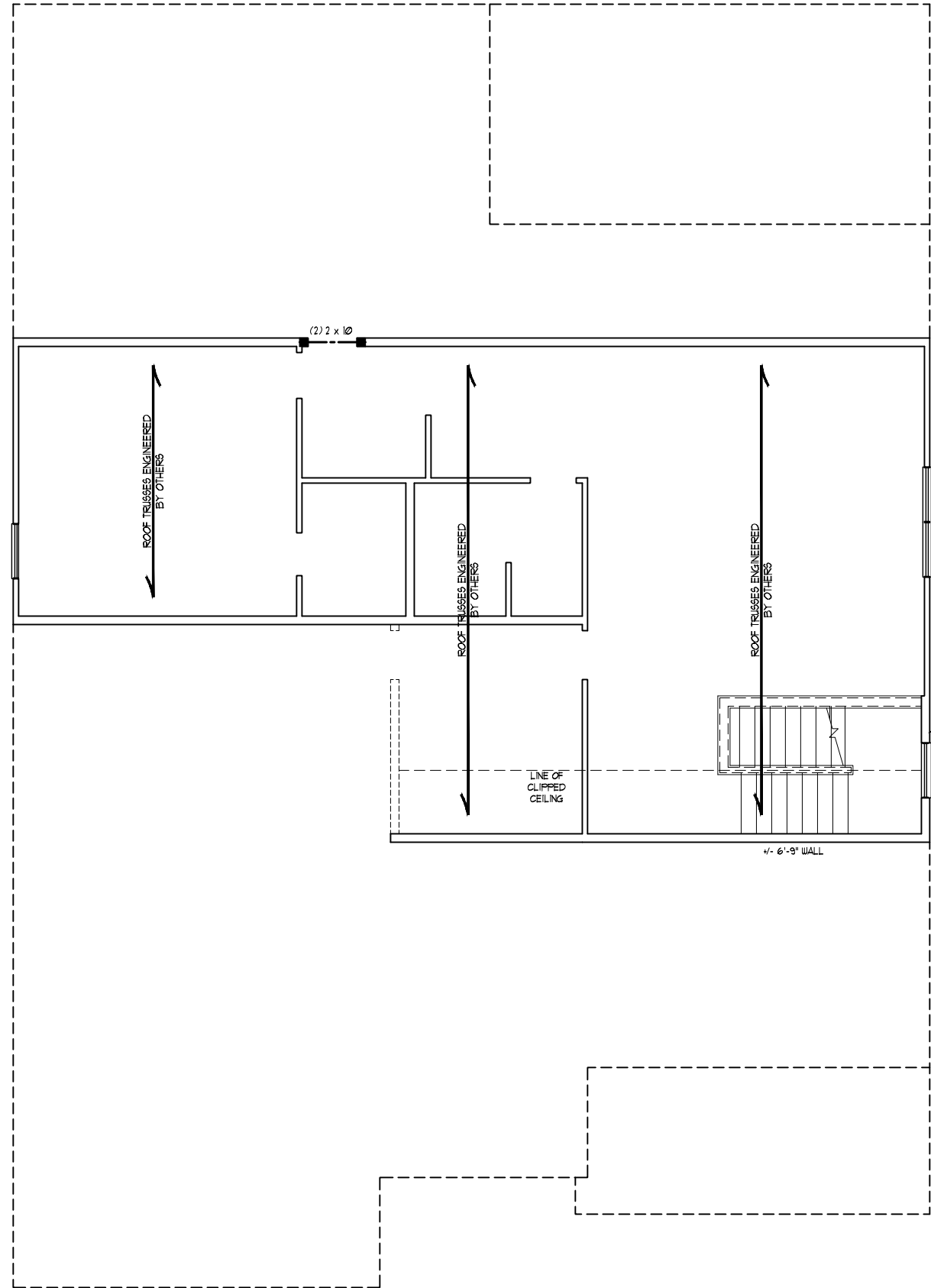

2 x 6 @ 16" O.C. BALLOON FRAMED WALL FROM BELOW. INSTALL (2) BALLOON FRAMED KING STUDS EA. SIDE OF WINDOW.

BRACED WALL DESIGN NOTES:

- BRACED WALL DESIGN PER SECTION R602.10.5 "WALL BRACING BY ENGINEERED DESIGN" OF THE NCR 2018 EDITION USING BRACING MATERIALS AND METHODS LISTED IN TABLE R602.10.1 ALONG WITH ALTERNATIVE MATERIALS AND METHODS THAT COMPLY WITH ACCEPTED ENGINEERING PRACTICE. BRACED WALL DESIGN IS NOT PRESCRIPTIVE.
- SHEATH ALL EXTERIOR WALLS w/ 7/16" OSB TO PROVIDE CS-WSP WALL BRACING THAT WILL BRACE THE STRUCTURE FOR ALL LATERAL LOADS AS REQUIRED BY THE NCR 2018 EDITION.
- CS-WSP REFERS TO "CONTINUOUSLY SHEATHED WOOD STRUCTURAL PANELS." CONTRACTOR IS TO INSTALL 7/16" OSB ON ALL EXTERIOR WALLS ATTACHED w/ 8d NAILS SPACED 6" O.C. ALONG PANEL EDGES AND 12" O.C. IN THE FIELD.
- GB REFERS TO "GYPSUM BOARD." CONTRACTOR IS TO INSTALL 1/2" (MIN.) GYPSUM BOARD ON BOTH SIDES OF WALL WHERE NOTED ON THE PLANS ATTACHED WITH 1 1/4" LONG #6 SCREWS OR 1 5/8" LONG 5d COOLER NAILS SPACED 7" O.C. ALONG PANEL EDGES AND IN THE FIELD.
- BRACED WALL DESIGN APPLIED IN WIND ZONES UP TO 130 MPH. FOR HIGH WIND ZONES, BRACED WALLS ARE TO BE CONSTRUCTED IN ACCORDANCE WITH CHAPTER 45 OF THE NCR 2018 EDITION.
- SEE NOTES AND DETAIL SHEETS FOR ADDITIONAL BRACED WALL INFORMATION.

STRUCTURAL NOTES:

- ALL FRAMING LUMBER TO BE #2 SFF OR #2 SYP (UNO).
- ALL LOAD BEARING HEADERS TO BE (2) 2 x 6 (UNO).
- WINDOW AND DOOR HEADERS TO BE SUPPORTED w/ (1) JACK STUD AND (1) KING STUD EA. END (UNO). SEE TABLE R602.15 FOR ADDITIONAL KING STUD REQUIREMENTS.
- SQUARES DENOTE POINT LOADS WHICH REQUIRE SOLID BLOCKING TO GIRDER OR FOUNDATION. SQUARES TO BE (2) STUDS (UNO).
- REFER TO NOTES AND DETAIL SHEETS FOR ADDITIONAL STRUCTURAL INFORMATION.

TABLE R602.15
MINIMUM NUMBER OF FULL HEIGHT KING STUDS AT EACH END OF HEADERS IN EXTERIOR WALLS

HEADER SPAN (FEET)	MINIMUM NUMBER OF FULL HEIGHT STUDS (KINGS)
UP TO 3'	1
> 3' TO 6'	2
> 6' TO 9'	3
> 9' TO 12'	4
> 12' TO 15'	5

DATE: APRIL 20, 2023

SCALE: 1/4" = 1'-0"

DRAWN BY: MAIN STREET DESIGNS

ENGINEERED BY: WFB

S-4b
CEILING
FRAMING PLAN

OPTIONAL 2ND FLOOR w/ BEDROOM

SCALE NOTE:
LARGE FORMAT PRINTS ARE TO SCALE AS NOTED.
11" x 17" PRINTS ARE ONE HALF THE NOTED SCALE

PRINCE PLACE LOT 44



4/20/2023

**J.S. THOMPSON
ENGINEERING, INC**
333 EAST SIX FORKS ROAD, SUITE 180, RALEIGH, NC 27609
PHONE: (919) 789-9919 FAX: (919) 789-9921
N.C. LICENSE NO.: C1733

MAGNOLIA
DAVIDSON HOMES

- STRUCTURAL NOTES:**
- ALL FRAMING LUMBER TO BE #2 SFF OR #2 SYP (UNO).
 - STICK FRAME OVER-FRAMED ROOF SECTIONS W/ 2 x 8 RIDGES, 2 x 6 RAFTERS @ 16" O.C. AND FLAT 2 x 10 VALLEYS OR USE VALLEY TRUSSES.
 - FASTEN FLAT VALLEYS TO RAFTERS OR TRUSSES WITH SIMPSON H25A HURRICANE TIES @ 32" O.C. MAX. PASS HURRICANE TIES THROUGH NOTCH IN ROOF SHEATHING. EACH RAFTER IS TO BE FASTENED TO THE FLAT VALLEY WITH A MIN. OF (6) 12d TOE NAILS.
 - REFER TO SECTION R202.11 OF THE 2018 NRC FOR REQUIRED UPLIFT RESISTANCE AT RAFTERS AND TRUSSES.
 - REFER TO NOTES AND DETAIL SHEETS FOR ADDITIONAL STRUCTURAL INFORMATION.

NOTE: REFER TO ARCHITECTURAL DRAWINGS FOR ROOF PITCHES, PLATE HEIGHTS, DIMENSIONS, OVERHANG WIDTHS, AND ATTIC VENT CALCS.

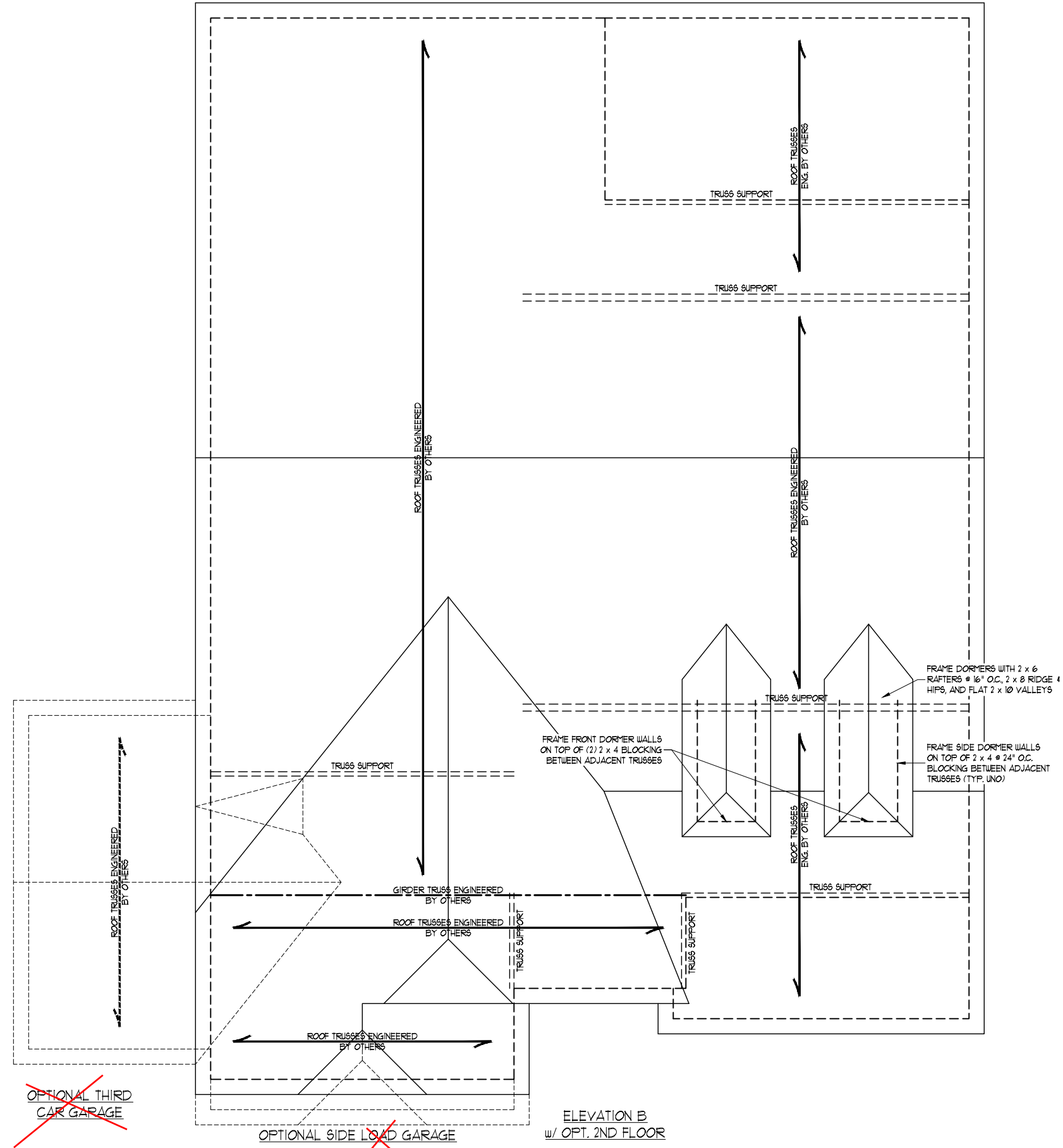

DATE: APRIL 20, 2023
SCALE: 1/4" = 1'-0"
DRAWN BY: MAIN STREET DESIGNS
ENGINEERED BY: WFB

S-5.2b
ROOF FRAMING
PLAN

GENERAL WALL BRACING NOTES:

1. WALL BRACING DESIGNED IN ACCORDANCE WITH CHAPTER 6 OF THE 2018 NC RESIDENTIAL BUILDING CODE (NRC). TABLES AND FIGURES REFERENCED ARE FROM THE 2018 NRC.
2. SEE THIS SHEET FOR GENERAL DETAILS. REFER TO THE 2018 NRC FOR ADDITIONAL INFORMATION AS NEEDED.
3. BRACED EXTERIOR WALLS SUPPORTING ROOF TRUSSES AND RAFTERS, INCLUDING STORIES BELOW THE TOP FLOOR, HAVE BEEN DESIGNED PER R602.3.5 (3). WALL SHEATHING AND FASTENERS HAVE BEEN DESIGNED TO RESIST COMBINED UPLIFT AND SHEAR FORCES IN ACCORDANCE WITH ACCEPTED ENGINEERING PRACTICE.
4. SEE STRUCTURAL SHEETS FOR BRACED WALL LOCATIONS, DIMENSIONS, HOLD DOWN TYPE AND LOCATIONS, BRACED WALL LINE KEY WITH WALL DESIGN SUMMARY OF REQUIRED/PROVIDED TOTALS FOR EACH WALL LINE AND ANY SPECIAL NOTES OR REQUIREMENTS.
5. ALL EXTERIOR WALLS ARE TO BE SHEATHED WITH CS-WSP IN ACCORDANCE WITH SECTION R602.10.3 UNLESS NOTED OTHERWISE.
6. ALL EXTERIOR AND INTERIOR WALLS TO HAVE 1/2" GYPSUM INSTALLED. WHEN NOT USING METHOD "GB", GYPSUM TO BE FASTENED PER TABLE R102.3.5. METHOD GB TO BE FASTENED PER TABLE R602.10.1.
7. CS-WSP REFERS TO THE "CONTINUOUS SHEATHING - WOOD STRUCTURAL PANELS" WALL BRACING METHOD. 7/16" OSB SHEATHING IS TO BE INSTALLED ON ALL EXTERIOR WALLS ATTACHED w/ 6d COMMON NAILS OR 8d (2 1/2" LONG x 0.131" DIAMETER) NAILS SPACED 6" O.C. ALONG PANEL EDGES AND 12" O.C. IN THE FIELD (UNO).
8. GB REFERS TO THE "GYPSUM BOARD" WALL BRACING METHOD. 1/2" (MIN) GYPSUM WALL BOARD IS TO BE INSTALLED ON BOTH SIDES OF THE BRACED WALL FASTENED WITH 1 1/4" SCREWS OR 1 5/8" NAILS SPACED 1" O.C. ALONG PANEL EDGES INCLUDING TOP AND BOTTOM PLATES AND INTERMEDIATE SUPPORTS (UNO). VERIFY ALL FASTENER OPTIONS FOR 1/2" AND 5/8" GYPSUM PRIOR TO CONSTRUCTION. FOR INTERIOR FASTENER OPTIONS SEE TABLE R102.3.5. FOR EXTERIOR FASTENER OPTIONS SEE TABLE R602.3(1). EXTERIOR GB TO BE INSTALLED VERTICALLY.
9. REQUIRED BRACED WALL LENGTH FOR EACH SIDE OF THE CIRCUMSCRIBED RECTANGLE ARE INTERPOLATED PER TABLE R602.10.3. METHOD CS-WSP CONTRIBUTES ITS ACTUAL LENGTH, METHOD GB CONTRIBUTES 5 ITS ACTUAL LENGTH, AND METHOD PF CONTRIBUTES 15 TIMES ITS ACTUAL LENGTH.

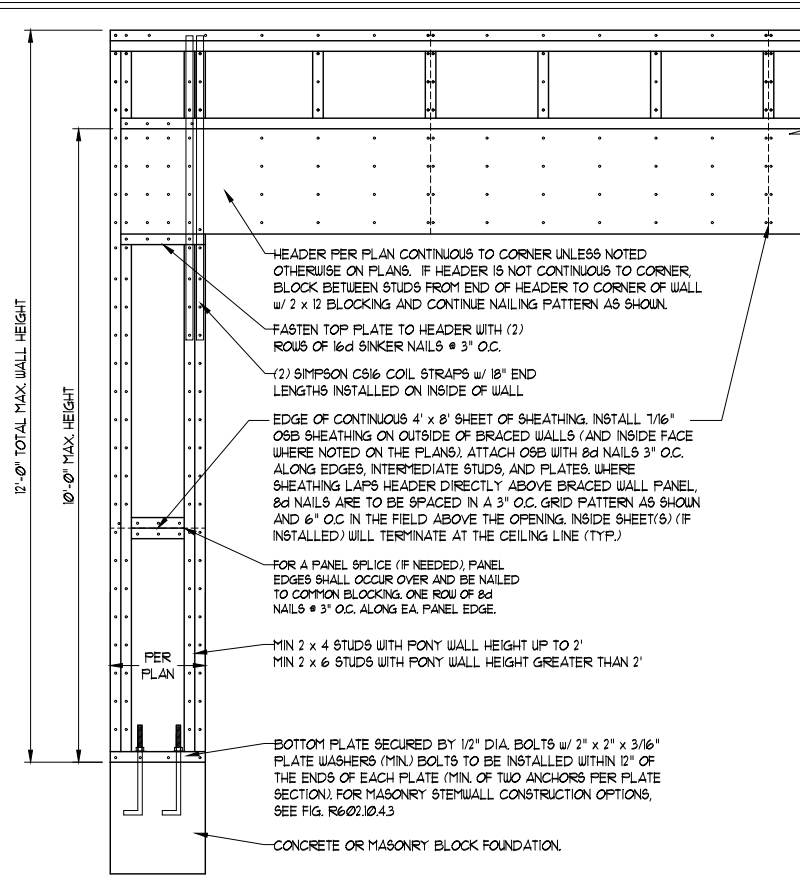

OVER CONCRETE OR MASONRY BLOCK FOUNDATION

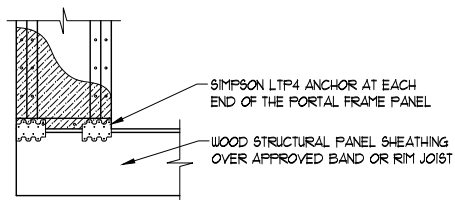

OVER RAISED WOOD FLOOR - FRAMING ANCHOR OPTION
 * APPLICABLE w/ GREATER THAN 12" KNEE WALL HEIGHTS
 IN CRAWL SPACE AND ABOVE FRAMED BASEMENT WALLS *

METHOD PF-PORTAL FRAME DETAIL ①

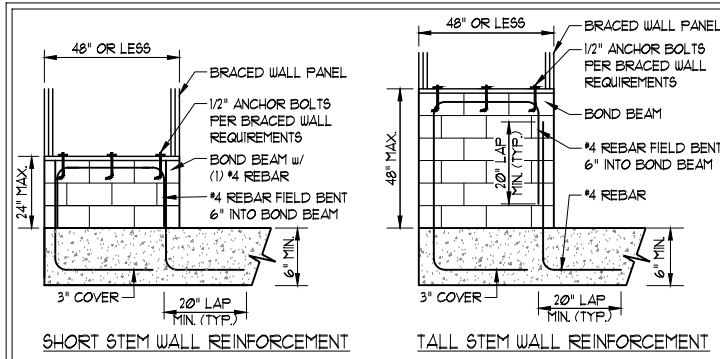

SHORT STEM WALL REINFORCEMENT

TALL STEM WALL REINFORCEMENT

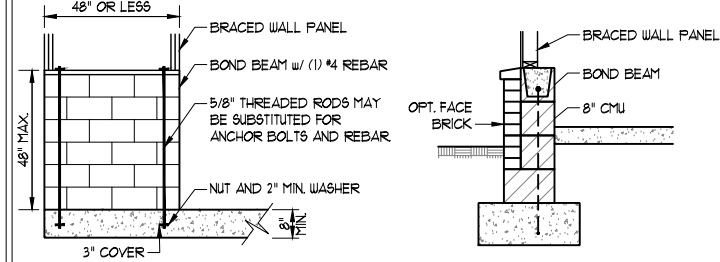

TYPICAL STEM WALL SECTION

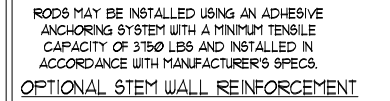

OPTIONAL STEM WALL REINFORCEMENT

NOTE: GROUT BOND BEAMS AND ALL CELLS WHICH CONTAIN REBAR, THREADED RODS AND ANCHOR BOLTS

MASONRY STEM WALLS SUPPORTING BRACED WALL PANELS ②

PER FIGURE R602.10.4.3

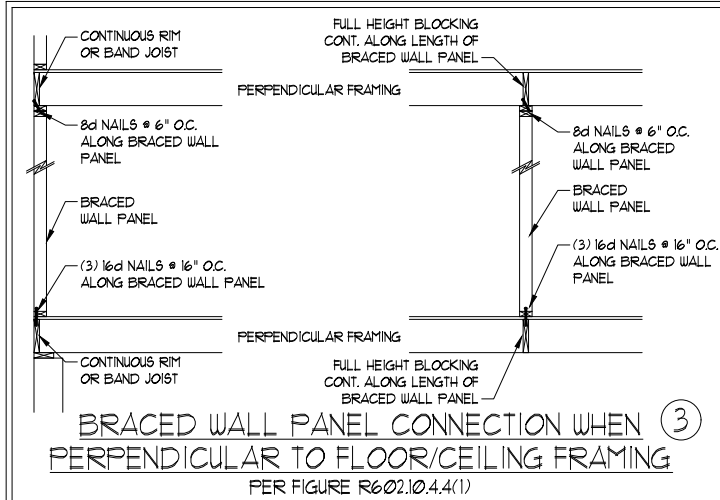

BRACED WALL PANEL CONNECTION WHEN PERPENDICULAR TO FLOOR/CEILING FRAMING ③

PER FIGURE R602.10.4.4(1)

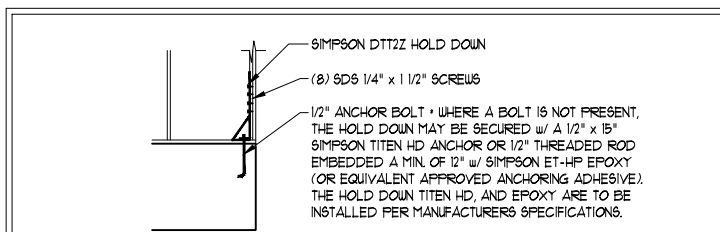

HOLD DOWN DETAIL FOR MASONRY FOUNDATION OR MONOLITHIC SLAB ④

* APPLICABLE ONLY WHERE SPECIFIED ON PLAN *

TYPICAL EXTERIOR CORNER FRAMING FOR CONTINUOUS SHEATHING ⑤

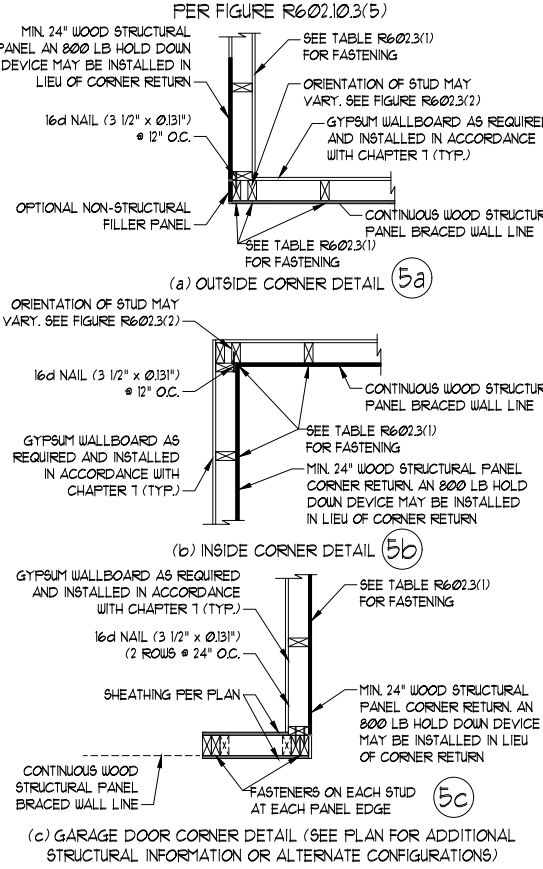

BRACED WALL PANEL CONNECTION WHEN PARALLEL TO FLOOR/CEILING FRAMING ⑥

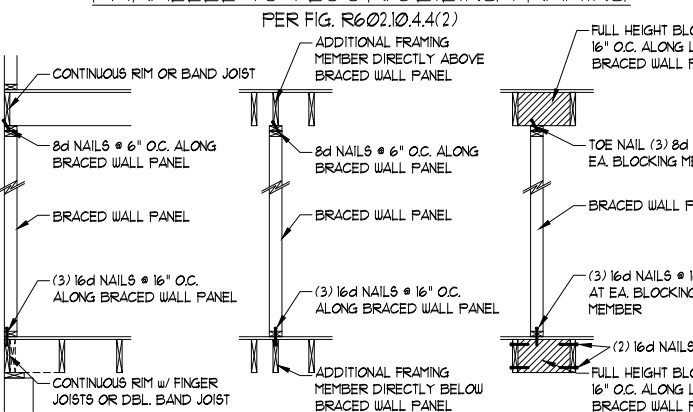

This sealed page is to be used in conjunction with a full plan set engineered by J.S. Thompson Engineering, Inc. only. Use of this individual sealed page within architectural pages or shop drawings by others is a punishable offense under N.C. Statute § 89C-23

SCALE NOTE:
 LARGE FORMAT PRINTS ARE TO SCALE AS NOTED.
 11" x 17" PRINTS ARE ONE HALF THE NOTED SCALE

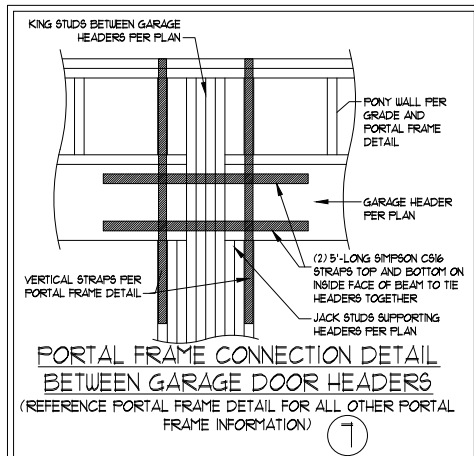

PORTAL FRAME CONNECTION DETAIL BETWEEN GARAGE DOOR HEADERS (REFERENCE PORTAL FRAME DETAIL FOR ALL OTHER PORTAL FRAME INFORMATION) ⑦

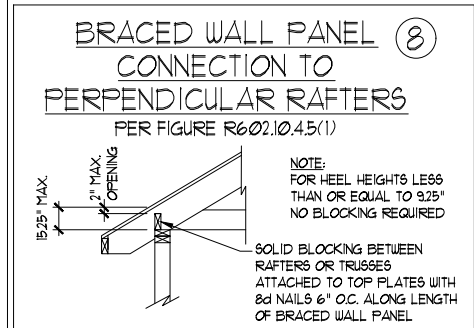

BRACED WALL PANEL CONNECTION TO PERPENDICULAR RAFTERS ⑧
 PER FIGURE R602.10.4.5(1)
 NOTE: FOR HEEL HEIGHTS LESS THAN OR EQUAL TO 9.25" NO BLOCKING REQUIRED
 SOLID BLOCKING BETWEEN RAFTERS OR TRUSSES ATTACHED TO TOP PLATES WITH 8d NAILS 6" O.C. ALONG LENGTH OF BRACED WALL PANEL

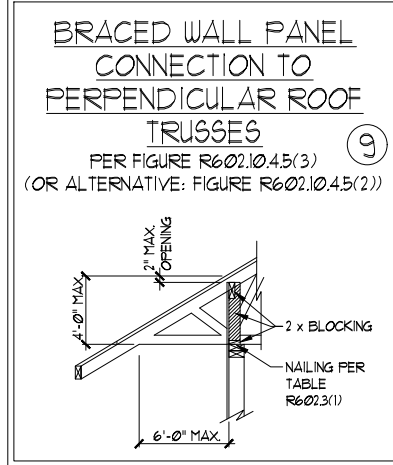

BRACED WALL PANEL CONNECTION TO PERPENDICULAR ROOF TRUSSES ⑨
 PER FIGURE R602.10.4.5(3)
 (OR ALTERNATIVE: FIGURE R602.10.4.5(2))



J.S. THOMPSON ENGINEERING, INC
 333 EAST SIX FORKS ROAD, SUITE 180, RALEIGH, NC 27609
 PHONE: (919) 789-9919 FAX: (919) 789-9921
 N.C. LICENSE NO.: C-1733

MAGNOLIA DAVIDSON HOMES

DATE: APRIL 20, 2023
 SCALE: 1/4" = 1'-0"
 DRAWN BY: MAIN STREET DESIGNS
 ENGINEERED BY: WFB

D-4 WALL BRACING NOTES AND DETAILS

4/20/2023

GENERAL NOTES

- ENGINEER'S SEAL APPLIES ONLY TO STRUCTURAL COMPONENTS INCLUDING ROOF RAFTERS, HIPs, VALLEYS, RIDGES, FLOORS, WALLS, BEAMS, HEADERS, CANTILEVERS, OFFSET LOAD BEARING WALLS, PIERS, GIRDER SYSTEM AND FOOTING. ENGINEER'S SEAL DOES NOT CERTIFY DIMENSIONAL ACCURACY OF ARCHITECTURAL LAYOUT INCLUDING ROOF. ENGINEER'S SEAL DOES NOT APPLY TO I-JOIST OR FLOOR/ROOF TRUSS LAYOUT DESIGN AND ACCURACY.
- ALL CONSTRUCTION SHALL CONFORM TO THE LATEST REQUIREMENTS OF THE NORTH CAROLINA RESIDENTIAL CODE (NRC), 2018 EDITION, PLUS ALL LOCAL CODES AND REGULATIONS. THE STRUCTURAL ENGINEER IS NOT RESPONSIBLE FOR, AND WILL NOT HAVE CONTROL OF, CONSTRUCTION MEANS, METHODS, TECHNIQUES, SEQUENCES OR PROCEDURES, OR SAFETY PRECAUTIONS AND PROGRAMS IN CONNECTION WITH THE CONSTRUCTION WORK. NOR WILL THE ENGINEER BE RESPONSIBLE FOR THE CONTRACTORS FAILURE TO CARRY OUT THE CONSTRUCTION WORK IN ACCORDANCE WITH THE CONTRACT DOCUMENTS.
- STRUCTURAL DESIGN BASED ON THE PROVISIONS OF THE NRC, 2018 EDITION (R301.4 - R301.7)

DESIGN CRITERIA:	LIVE LOAD (PSF)	DEAD LOAD (PSF)	DEFLECTION (IN)
ATTIC WITH LIMITED STORAGE	20	10	L/240 (L/360 w/ BRITTLE FINISHES)
ATTIC WITHOUT STORAGE	10	10	L/360
DECKS	40	10	L/360
EXTERIOR BALCONIES	40	10	L/360
FIRE ESCAPES	40	10	L/360
HANDRAILS/GUARDRAILS	200 LB OR 50 (PLF)	10	L/360
PASSENGER VEHICLE GARAGE	50	10	L/360
ROOMS OTHER THAN SLEEPING ROOM	40	10	L/360
SLEEPING ROOMS	30	10	L/360
STAIRS	40	10	L/360
WIND LOAD	(BASED ON TABLE R301.2(4) WIND ZONE AND EXPOSURE)		
GROUND SNOW LOAD: P _g	20 (PSF)		

- I-JOIST SYSTEMS DESIGNED WITH 12 PSF DEAD LOAD AND DEFLECTION (IN) OF L/480
- FLOOR TRUSS SYSTEMS DESIGNED WITH 15 PSF DEAD LOAD

- FOR 115 AND 120 MPH WIND ZONES, FOUNDATION ANCHORAGE IS TO COMPLY WITH SECTION R403.16 OF THE NRC, 2018 EDITION. FOR 130 MPH, 140 MPH, AND 150 MPH WIND ZONES, FOUNDATION ANCHORAGE IS TO COMPLY WITH SECTION 4504 OF THE NRC, 2018 EDITION.
- ENERGY EFFICIENCY COMPLIANCE AND INSULATION VALUES OF THE BUILDING TO BE IN ACCORDANCE WITH CHAPTER 11 OF THE NRC, 2018 EDITION.

FOOTING AND FOUNDATION NOTES

- FOUNDATION DESIGN BASED ON A MINIMUM ALLOWABLE BEARING CAPACITY OF 2000 PSF. CONTACT GEOTECHNICAL ENGINEER IF BEARING CAPACITY IS NOT ACHIEVED.
- FOR ALL CONCRETE SLABS AND FOOTINGS, THE AREA WITHIN THE PERIMETER OF THE BUILDING ENVELOPE SHALL HAVE ALL VEGETATION, TOP SOIL AND FOREIGN MATERIAL REMOVED. FILL MATERIAL SHALL BE FREE OF VEGETATION AND FOREIGN MATERIAL. THE FILL SHALL BE COMPACTED TO ASSURE UNIFORM SUPPORT OF THE SLAB, AND EXCEPT WHERE APPROVED, THE FILL DEPTHS SHALL NOT EXCEED 24" FOR CLEAN SAND OR GRAVEL. A 4" THICK BASED COURSE CONSISTING OF CLEAN GRADED SAND OR GRAVEL SHALL BE PLACED. A BASE COURSE IS NOT REQUIRED WHERE A CONCRETE SLAB IS INSTALLED ON WELL-DRAINED OR SAND-GRAVEL MIXTURE SOILS CLASSIFIED AS GROUP 1, ACCORDING TO THE UNITED SOIL CLASSIFICATION SYSTEM IN ACCORDANCE WITH TABLE R405.1 OF THE NRC, 2018 EDITION.
- PROPERLY DEWATER EXCAVATION PRIOR TO POURING CONCRETE WHEN BOTTOM OF CONCRETE SLAB IS AT OR BELOW WATER TABLE. IF APPLICABLE, 3/4" - 1" DEEP CONTROL JOINTS ARE TO BE SAWED WITHIN 4 TO 12 HOURS OF CONCRETE FINISHING AND WALL LOCATIONS HAVE BEEN MARKED. ADJUST WHERE NECESSARY.
- CONCRETE SHALL CONFORM TO SECTION R402.2 OF THE NRC, 2018 EDITION. CONCRETE REINFORCING STEEL TO BE ASTM A615 GRADE 60. WELDED WIRE FABRIC TO BE ASTM A105. MAINTAIN A MINIMUM CONCRETE COVER AROUND REINFORCING STEEL OF 3" IN FOOTINGS AND 1 1/2" IN SLABS. FOR POURED CONCRETE WALLS, CONCRETE COVER FOR REINFORCING STEEL MEASURED FROM THE INSIDE FACE OF THE WALL SHALL NOT BE LESS THAN 3/4". CONCRETE COVER FOR REINFORCING STEEL MEASURED FROM THE OUTSIDE FACE OF THE WALL SHALL NOT BE LESS THAN 1 1/2" FOR #5 BARS OR SMALLER, AND NOT LESS THAN 2" FOR #6 BARS OR LARGER.
- MASONRY UNITS TO CONFORM TO ACE 530/ASCE 5/TMS 402. MORTAR SHALL CONFORM TO ASTM C270.
- THE UNSUPPORTED HEIGHT OF MASONRY PIERS SHALL NOT EXCEED FOUR TIMES THEIR LEAST DIMENSION FOR UNFILLED HOLLOW CONCRETE MASONRY UNITS AND TEN TIMES THEIR LEAST DIMENSION FOR SOLID OR SOLID FILLED PIERS. PIERS MAY BE FILLED SOLID WITH CONCRETE OR TYPE M OR S MORTAR. PIERS AND WALLS SHALL BE CAPPED WITH 8" OF SOLID MASONRY.
- THE CENTER OF EACH OF THE PIERS SHALL BEAR IN THE MIDDLE THIRD OF ITS RESPECTIVE FOOTING. EACH GIRDER SHALL BEAR IN THE MIDDLE THIRD OF THE PIERS.
- ALL CONCRETE AND MASONRY FOUNDATION WALLS ARE TO BE CONSTRUCTED IN ACCORDANCE WITH THE PROVISIONS OF SECTION R404 OF THE NRC, 2018 EDITION OR IN ACCORDANCE WITH ACI 318, ACI 332, NCMA TR68-A OR ACE 530/ASCE 5/TMS 402. MASONRY FOUNDATION WALLS ARE TO BE REINFORCED PER TABLE R404.1(1), R404.1(2), R404.1(3), OR R404.1(4) OF THE NRC, 2018 EDITION. CONCRETE FOUNDATION WALLS ARE TO BE REINFORCED PER TABLE R404.1(5) OF THE NRC, 2018 EDITION. STEP CONCRETE FOUNDATION WALLS TO 2 x 6 FRAMED WALLS AT 16" O.C. WHERE GRADE PERMITS (UNO).

FRAMING NOTES

- ALL FRAMING LUMBER SHALL BE #2 SFF (F_b = 875 PSI, F_v = 375 PSI, E = 1600000 PSI) OR #2 SYP (F_b = 975 PSI, F_v = 175 PSI, E = 1600000 PSI) MINIMUM UNLESS NOTED OTHERWISE (UNO). ALL TREATED LUMBER SHALL BE #2 SYP MINIMUM UNLESS NOTED OTHERWISE (UNO).
- LAMINATED VENEER LUMBER (LVL) SHALL HAVE THE FOLLOWING MINIMUM PROPERTIES: F_b = 2600 PSI, F_v = 285 PSI, E = 1900000 PSI. LAMINATED STRAND LUMBER (LSL) SHALL HAVE THE FOLLOWING MINIMUM PROPERTIES: F_b = 2325 PSI, F_v = 310 PSI, E = 1550000 PSI. PARALLEL STRAND LUMBER (PSL) UP TO 1" DEPTH SHALL HAVE THE FOLLOWING MINIMUM PROPERTIES: F_c = 2500 PSI, E = 1800000 PSI. PARALLEL STRAND LUMBER (PSL) MORE THAN 1" DEPTH SHALL HAVE THE FOLLOWING MINIMUM PROPERTIES: F_c = 2900 PSI, E = 2000000 PSI. INSTALL ALL CONNECTIONS PER MANUFACTURER'S SPECIFICATIONS.
- STRUCTURAL STEEL SHALL CONFORM TO THE FOLLOWING ASTM SPECIFICATIONS

A. W AND WT SHAPES:	ASTM A992
B. CHANNELS AND ANGLES:	ASTM A36
C. PLATES AND BARS:	ASTM A36
D. HOLLOW STRUCTURAL SECTIONS:	ASTM A500 GRADE B
E. STEEL PIPE:	ASTM A53, GRADE B, TYPE E OR S
- STEEL BEAMS SHALL BE SUPPORTED AT EACH END WITH A MINIMUM BEARING LENGTH OF 3 1/2" AND FULL FLANGE WIDTH (UNO). PROVIDE SOLID BEARING FROM BEAM SUPPORT TO FOUNDATION. BEAMS SHALL BE ATTACHED AT THE BOTTOM FLANGE TO EACH SUPPORT AS FOLLOWS (UNO):

A. WOOD FRAMING	(2) 1/2" DIA. x 4" LONG LAG SCREWS
B. CONCRETE	(2) 1/2" DIA. x 4" WEDGE ANCHORS
C. MASONRY (FULLY GROUTED)	(2) 1/2" DIA. x 4" LONG SIMPSON TITEN HD ANCHORS

LATERAL SUPPORT IS CONSIDERED ADEQUATE PROVIDING THE JOISTS ARE TOE NAILED TO THE 2x NAILER ON TOP OF THE STEEL BEAM, AND THE 2x NAILER IS SECURED TO THE TOP OF THE STEEL BEAM w/ (2) ROWS OF SELF TAPPING SCREWS @ 16" O.C. OR (2) ROWS OF 1/2" DIAMETER BOLTS @ 16" O.C. IF 1/2" BOLTS ARE USED TO FASTEN THE NAILER, THE STEEL BEAM SHALL BE FABRICATED w/ (2) ROWS OF 9/16" DIAMETER HOLES @ 16" O.C.
- SQUARES DENOTE POINT LOADS WHICH REQUIRE SOLID BLOCKING TO GIRDER OR FOUNDATION. SHADED SQUARES DENOTE POINT LOADS FROM ABOVE WHICH REQUIRE SOLID BLOCKING TO SUPPORTING MEMBER BELOW.
- ALL LOAD BEARING HEADERS TO CONFORM TO TABLE R602.1(1) AND R602.1(2) OF THE NRC, 2018 EDITION OR BE (2) 2 x 6 WITH (1) JACK AND (1) KING STUD EACH END (UNO), WHICHEVER IS GREATER. ALL HEADERS TO BE SECURED TO EACH JACK STUD WITH (4) 8d NAILS. ALL BEAMS TO BE SUPPORTED WITH (2) STUDS AT EACH BEARING POINT (UNO). INSTALL KING STUDS PER SECTION R602.15 OF THE NORTH CAROLINA RESIDENTIAL CODE, 2018 EDITION.
- ALL BEAMS, HEADERS, OR GIRDER TRUSSES PARALLEL TO WALL ARE TO BEAR FULLY ON (1) JACK OR (2) STUDS MINIMUM OR THE NUMBER OF JACKS OR STUDS NOTED. ALL BEAMS OR GIRDER TRUSSES PERPENDICULAR TO WALL AND SUPPORTED BY (3) STUDS OR LESS ARE TO HAVE 1 1/2" MINIMUM BEARING (UNO). ALL BEAMS OR GIRDER TRUSSES PERPENDICULAR TO WALL AND SUPPORTED BY MORE THAN (3) STUDS OR OTHER NOTED COLUMN ARE TO BEAR FULLY ON SUPPORT COLUMN FOR ENTIRE WALL DEPTH (UNO). BEAM ENDS THAT BUTT INTO ONE ANOTHER ARE TO EACH BEAR EQUAL LENGTHS (UNO).
- FLITCH BEAMS SHALL BE BOLTED TOGETHER USING 1/2" DIAMETER BOLTS (ASTM A307) WITH WASHERS PLACED AT THREADED END OF BOLT. BOLTS SHALL BE SPACED AT 24" CENTERS (MAXIMUM), AND STAGGERED AT TOP AND BOTTOM OF BEAM (2" EDGE DISTANCE), WITH (2) BOLTS LOCATED AT 6" FROM EACH END (UNO).
- ALL I-JOIST OR TRUSS LAYOUTS ARE TO BE IN COMPLIANCE WITH THE OVERALL DESIGN SPECIFIED ON THE PLANS. ALL DEVIATIONS ARE TO BE BROUGHT TO THE ATTENTION OF THE ENGINEER OF RECORD PRIOR TO INSTALLATION.
- BRACED WALL PANELS SHALL BE CONSTRUCTED ACCORDING TO THE NORTH CAROLINA RESIDENTIAL CODE 2018 EDITION WALL BRACING CRITERIA. THE AMOUNT, LENGTH, AND LOCATION OF BRACING SHALL COMPLY WITH ALL APPLICABLE TABLES IN SECTION R602.10.
- PROVIDE DOUBLE JOIST UNDER ALL WALLS PARALLEL TO FLOOR JOISTS. PROVIDE SUPPORT UNDER ALL WALLS PARALLEL TO FLOOR TRUSSES OR I-JOISTS PER MANUFACTURER'S SPECIFICATIONS. INSTALL BLOCKING BETWEEN JOISTS OR TRUSSES FOR POINT LOAD SUPPORT FOR ALL POINT LOADS ALONG OFFSET LOAD LINES.
- FOR ALL HEADERS SUPPORTING BRICK VENEER THAT ARE LESS THAN 8'-0" IN LENGTH, REST A 6" x 4" x 5/16" STEEL ANGLE WITH 6" MINIMUM EMBEDMENT AT SIDES FOR BRICK SUPPORT (UNO). FOR ALL HEADERS 8'-0" AND GREATER IN LENGTH, BOLT A 6" x 4" x 5/16" STEEL ANGLE TO HEADER WITH 1/2" LAG SCREWS AT 12" O.C. STAGGERED FOR BRICK SUPPORT. FOR ALL BRICK SUPPORT AT ROOF LINES, BOLT A 6" x 4" x 5/16" STEEL ANGLE TO (2) 2 x 10 BLOCKING INSTALLED w/ (4) 12d NAILS EA. PLY BETWEEN WALL STUDS WITH (2) ROWS OF 1/2" LAG SCREWS AT 12" O.C. STAGGERED AND IN ACCORDANCE WITH SECTION R703.2.1 OF THE NRC, 2018 EDITION.
- FOR STICK FRAMED ROOFS: CIRCLES DENOTE (3) 2 x 4 POSTS FOR ROOF MEMBER SUPPORT. HIP SPICES ARE TO BE SPACED A MINIMUM OF 8'-0". FASTEN MEMBERS WITH THREE ROWS OF 12d NAILS AT 16" O.C. FRAME DORMER WALLS ON TOP OF DOUBLE OR TRIPLE RAFTERS AS SHOWN (UNO).
- FOR TRUSSED ROOFS: FRAME DORMER WALLS ON TOP OF 2 x 4 LADDER FRAMING AT 24" O.C. BETWEEN ADJACENT ROOF TRUSSES. STICK FRAME OVER-FRAMED ROOF SECTIONS WITH 2 x 8 RIDGES, 2 x 6 RAFTERS AT 16" O.C. AND FLAT 2 x 10 VALLEYS (UNO).
- ALL 4 x 4 AND 6 x 6 POSTS TO BE INSTALLED WITH 100 LB CAPACITY UPLIFT CONNECTORS TOP AND BOTTOM (UNO). POSTS MAY BE SECURED USING ONE SIMPSON H6 OR L7912 UPLIFT CONNECTOR FASTENED TO THE BAND AT THE BOTTOM AND THE BEAM AT THE TOP OF EACH POST. ONE 16" SECTION OF SIMPSON CS16 COIL STRAPPING WITH (8) 8d HDG NAILS AT EACH END MAY BE USED IN LIEU OF EACH TWIST STRAP IF DESIRED. FOR MASONRY OR CONCRETE FOUNDATION USE SIMPSON POST BASE.

SCALE NOTE:
 LARGE FORMAT PRINTS ARE TO SCALE AS NOTED.
 11" x 17" PRINTS ARE ONE HALF THE NOTED SCALE

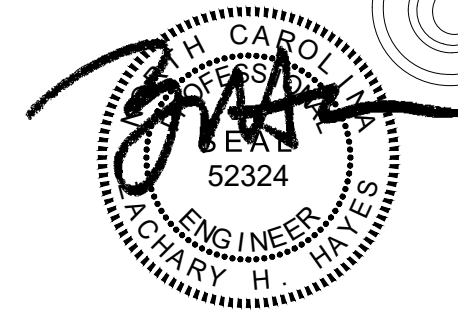

4/20/2023

J.S. THOMPSON
ENGINEERING, INC.
 333 EAST SIX FORKS ROAD, SUITE 180, RALEIGH, NC 27609
 PHONE: (919) 789-9919 FAX: (919) 789-9921
 N.C. LICENSE NO.: C-1733

MAGNOLIA
 DAVIDSON HOMES

DATE: APRIL 20, 2023
 SCALE: 1/4" = 1'-0"
 DRAWN BY: MAIN STREET DESIGNS
 ENGINEERED BY: WFB

This sealed page is to be used in conjunction with a full plan set engineered by J.S. Thompson Engineering, Inc. only. Use of this individual sealed page within architectural pages or shop drawings by others is a punishable offense under N.C. Statute § 89C-23

D-5
 STANDARD
 STRUCTURAL NOTES

THIS LAYOUT IS INTENDED FOR THE PURPOSE OF TRUSS LOCATION AND PLACEMENT ONLY. REFER TO THE BUILDING PLANS FOR ACTUAL BUILDING CONSTRUCTION.



DEDICATED TO QUALITY AND EXCELLENCE
200 EMMETT ROAD
DUNN, NORTH CAROLINA 28334
PHONE: 910-892-8400

PROJECT: **LOT 44 PRINCE PLACE**

CUSTOMER: **Davidson Homes**

MODEL: **Magnolia B w/Brdm 4 - Floor**

ORDER #: **38229A** PRINT DATE: **7/5/2023** DRAWN BY: **BES** SCALE: **N.T.S**

TOP LIVE LOAD: 40.0 lb/ft²

TOP DEAD LOAD: 10.0 lb/ft²

BOTTOM LIVE LOAD:

BOTTOM DEAD LOAD: 5.0 lb/ft²

GENERAL NOTES:

- DO NOT CUT OR MODIFY TRUSSES
- TRUSSES ARE SPACED 19.2" ON CENTER UNLESS OTHERWISE NOTED
- REFER TO THE INDIVIDUAL TRUSS DESIGN DRAWINGS FOR THE LOCATION OF LATERAL BRACING AND MULTI-PLY CONNECTION REQUIREMENTS.
- PER ANSI TPI 1-2002 THE TRUSS ENGINEER IS RESPONSIBLE FOR TRUSS TO TRUSS CONNECTIONS AND TRUSS PLY TO PLY CONNECTIONS. THIS TRUSS DESIGN PLAN RECOMMENDS TRUSS TO BEARING CONNECTIONS AND TRUSS TO BEAM CONNECTIONS WHICH SHALL BE REVIEWED BY THE BUILDING DESIGNER. IT IS THE RESPONSIBILITY OF THE BUILDING DESIGNER TO RESOLVE ALL ROOF FORCES ADEQUATELY TO THE FOUNDATION.

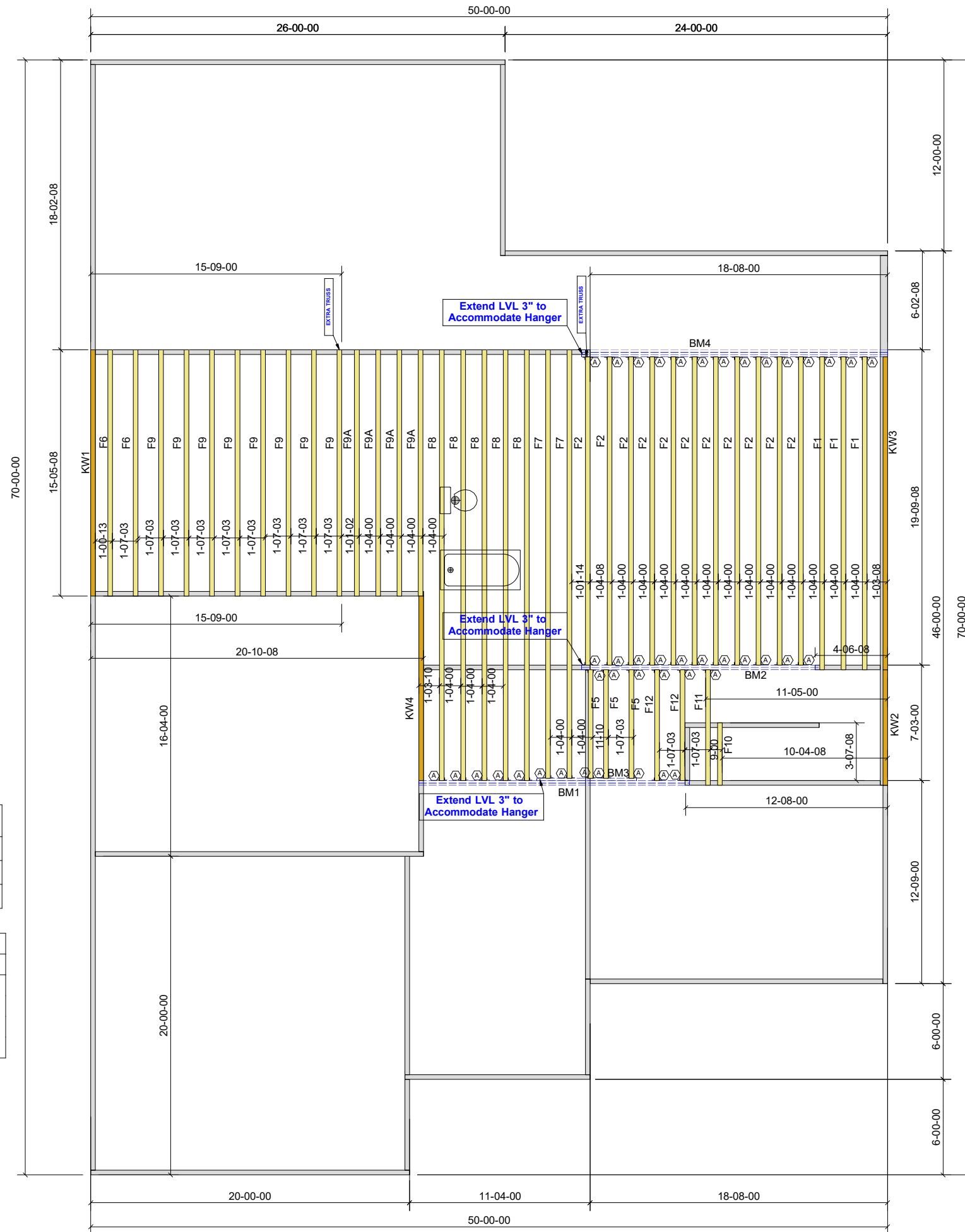

HANGER LIST		
A	LUS410	43
B	-	-
C	-	-

Products				
PlotID	Length	Product	Plies	Net Qty
BM1	18-00-00	1-3/4" x 14" LVL BY OTHERS	2	2
BM2	16-00-00	1-3/4" x 14" LVL BY OTHERS	2	2
BM3	8-00-00	1-3/4" x 14" LVL BY OTHERS	1	1
BM4	20-00-00	1-3/4" x 20" LVL BY OTHERS	3	3

Crawl Level Floor Area	1st Level Floor Area	2nd Level Floor Area
0	1122.25	0

THIS LAYOUT IS INTENDED FOR THE PURPOSE OF TRUSS LOCATION AND PLACEMENT ONLY. REFER TO THE BUILDING PLANS FOR ACTUAL BUILDING CONSTRUCTION.



DEDICATED TO QUALITY AND EXCELLENCE
 200 EMMETT ROAD
 DUNN, NORTH CAROLINA 28334
 PHONE: 910-892-8400

PROJECT: LOT 44 PRINCE PLACE

CUSTOMER: DAVIDSON HOMES

MODEL: Magnolia B w/ BnsRm - Brm4

ORDER #: 38228A PRINT DATE: 7/6/2023 DRAWN BY: BES SCALE: N.T.S

TOP LIVE LOAD: 20.0 lb/ft²

TOP DEAD LOAD: 10.0 lb/ft²

BOTTOM DEAD LOAD: 10.0 lb/ft²

WIND SPEED: 115 mph

GENERAL NOTES:

DO NOT CUT OR MODIFY TRUSSES
 TRUSSES ARE SPACED 24" ON CENTER UNLESS OTHERWISE NOTED
 REFER TO THE INDIVIDUAL TRUSS DESIGN DRAWINGS FOR THE LOCATION OF LATERAL BRACING AND MULTI-PLY CONNECTION REQUIREMENTS.
 PER ANSI TPI 1-2002 THE TRUSS ENGINEER IS RESPONSIBLE FOR TRUSS TO TRUSS CONNECTIONS AND TRUSS PLY TO PLY CONNECTIONS. THIS TRUSS PLAN RECOMMENDS TRUSS TO BEARING CONNECTIONS AND TRUSS TO BEAM CONNECTIONS WHICH SHALL BE REVIEWED BY THE BUILDING DESIGNER. IT IS THE RESPONSIBILITY OF THE BUILDING DESIGNER TO RESOLVE ALL ROOF FORCES ADEQUATELY TO THE FOUNDATION.

HANGER LIST		
A	LUS26	15
B	.	.
C	.	.

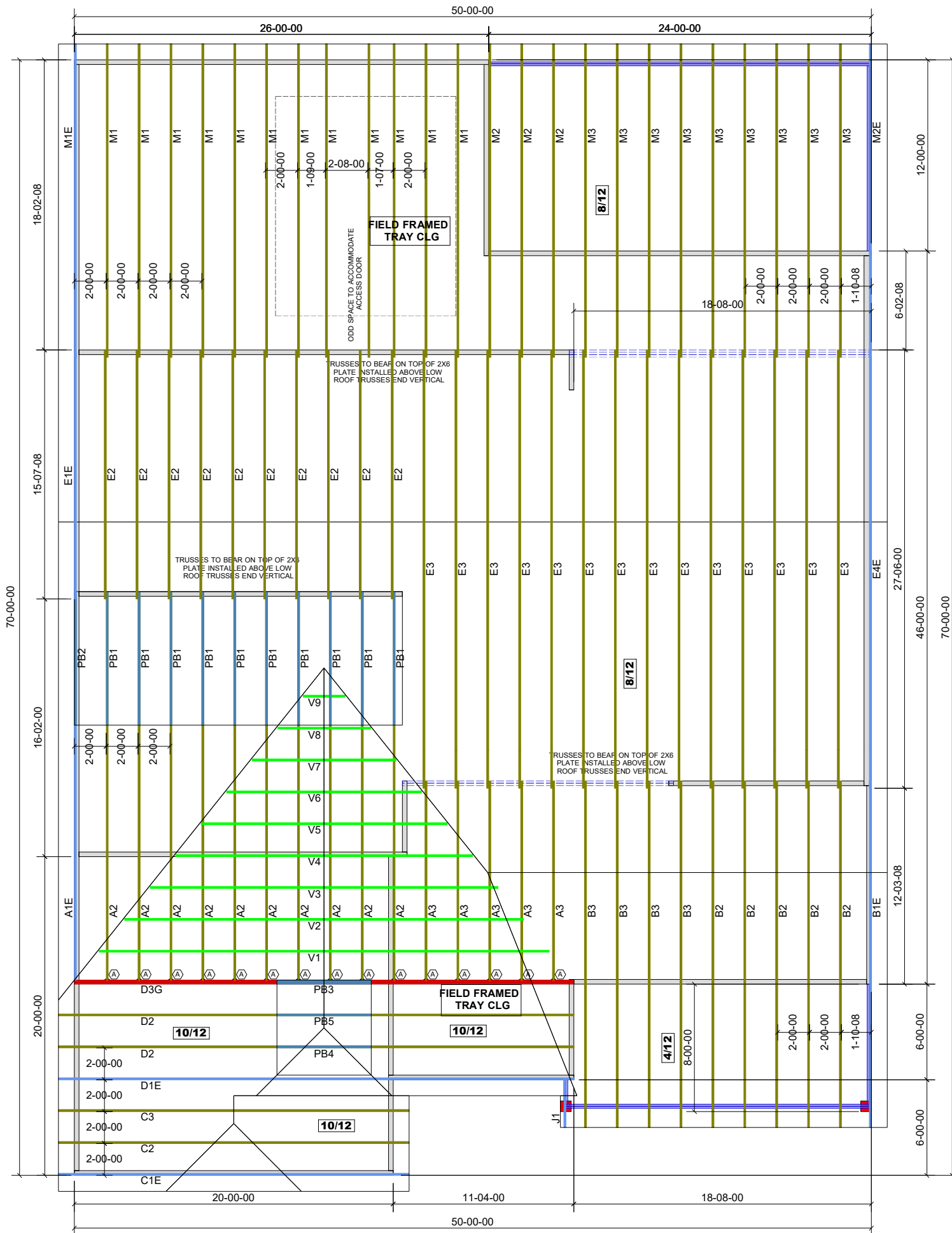

1st Level Roof Area	2nd Level Roof Area
4345.9	0