

RE: J0723-3614
 Lot 4 Jones Creek / Harnett

Trenco
 818 Soundside Rd
 Edenton, NC 27932

Site Information:

Customer: Project Name: J0723-3614
 Lot/Block: Model:
 Address: Subdivision:
 City: State:

General Truss Engineering Criteria & Design Loads (Individual Truss Design Drawings Show Special Loading Conditions):

Design Code: IRC2018/TPI2014 Design Program: MiTek 20/20 8.4
 Wind Code: ASCE 7-16 Wind Speed: 130 mph
 Roof Load: 40.0 psf Floor Load: N/A psf

This package includes 18 individual, dated Truss Design Drawings and 0 Additional Drawings.

No.	Seal#	Truss Name	Date
1	I58361093	A1-GE	5/16/2023
2	I58361094	A2	5/16/2023
3	I58361095	A3	5/16/2023
4	I58361096	A4	5/16/2023
5	I58361097	A6	5/16/2023
6	I58361098	A7-GE	5/16/2023
7	I58361099	B1-GE	5/16/2023
8	I58361100	B2	5/16/2023
9	I58361101	D1-GE	5/16/2023
10	I58361102	D2	5/16/2023
11	I58361103	D3	5/16/2023
12	I58361104	E1-GE	5/16/2023
13	I58361105	E2	5/16/2023
14	I58361106	E3	5/16/2023
15	I58361107	E4	5/16/2023
16	I58361108	VD-1	5/16/2023
17	I58361109	VD-2	5/16/2023
18	I58361110	VD-3	5/16/2023

The truss drawing(s) referenced above have been prepared by Truss Engineering Co. under my direct supervision based on the parameters provided by Comtech, Inc - Fayetteville.
 Truss Design Engineer's Name: Gilbert, Eric
 My license renewal date for the state of North Carolina is December 31, 2023.
 North Carolina COA: C-0844

IMPORTANT NOTE: The seal on these truss component designs is a certification that the engineer named is licensed in the jurisdiction(s) identified and that the designs comply with ANSI/TPI 1. These designs are based upon parameters shown (e.g., loads, supports, dimensions, shapes and design codes), which were given to TRENCO. Any project specific information included is for TRENCO customers file reference purpose only, and was not taken into account in the preparation of these designs. TRENCO has not independently verified the applicability of the design parameters or the designs for any particular building. Before use, the building designer should verify applicability of design parameters and properly incorporate these designs into the overall building design per ANSI/TPI 1, Chapter 2.



Job	Truss	Truss Type	Qty	Ply	Lot 4 Jones Creek / Harnett	158361093
J0723-3614	A1-GE	GABLE	1	1	Job Reference (optional)	

Comtech, Inc. Fayetteville, NC - 28314,

8.430 s Jan 6 2022 MiTek Industries, Inc. Mon May 15 15:23:54 2023 Page 1

ID:2GNsYO62BI49KgBFP3SlmayOXVO-RfC?PsB70Hq3NSgPqnL8w3ulTXbGKwrcDoi7J4zJC?f

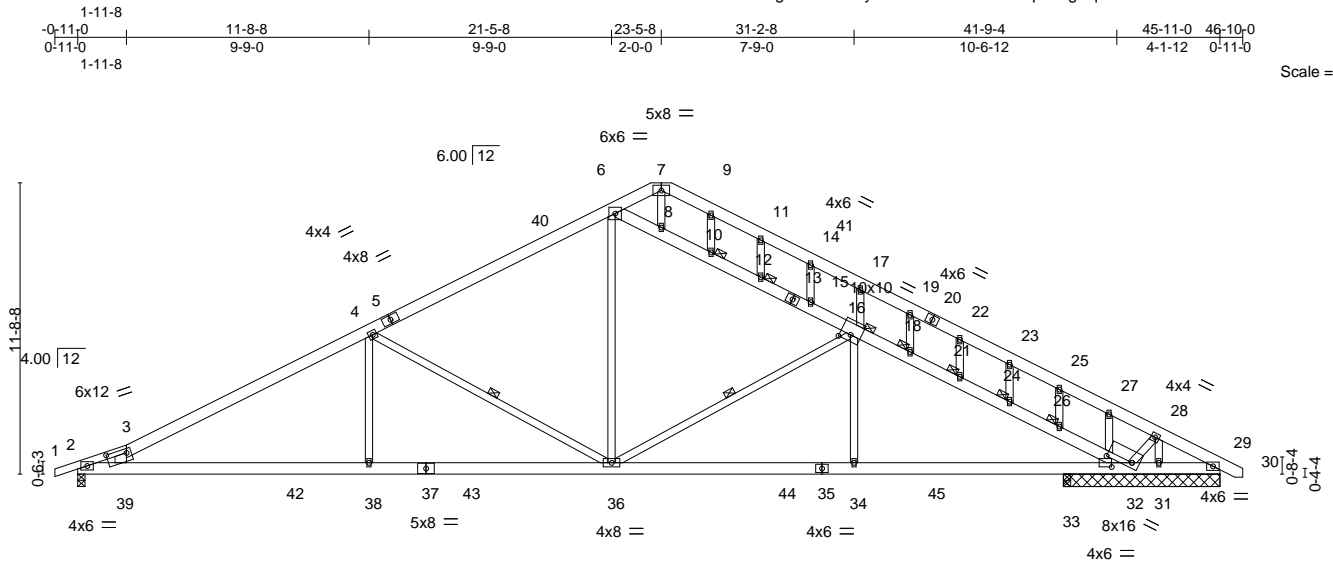

Scale = 1:92.6

Plate Offsets (X, Y)--	[3:0-9-12,0-2-0], [16:0-5-0,0-3-0], [32:1-0-8,0-2-8], [32:0-9-13,0-2-0]
------------------------	---

LOADING (psf)	SPACING-	2-0-0	CSI.	DEFL.	in (loc)	l/defl	L/d	PLATES	GRIP
TCLL 20.0	Plate Grip DOL	1.15	TC 0.93	Vert(LL)	-0.31 38-39	>999	360	MT20	244/190
TCDL 10.0	Lumber DOL	1.15	BC 0.60	Vert(CT)	-0.56 38-39	>850	240		
BCLL 0.0 *	Rep Stress Incr	YES	WB 0.77	Horz(CT)	0.11 29	n/a	n/a		
BCDL 10.0	Code IRC2018/TPI2014		Matrix-S	Wind(LL)	0.25 38-39	>999	240	Weight: 374 lb	FT = 20%

LUMBER-	BRACING-
TOP CHORD 2x6 SP No.1 *Except* 1-3: 2x4 SP No.1	TOP CHORD Structural wood sheathing directly applied or 2-2-0 oc purlins.
BOT CHORD 2x6 SP No.1 *Except* 2-37: 2x6 SP 2400F 2.0E	BOT CHORD Rigid ceiling directly applied or 6-0-0 oc bracing.
WEBS 2x4 SP No.2 *Except* 3-39: 2x6 SP No.1	WEBS 1 Row at midpt 4-36, 16-36
OTHERS 2x4 SP No.2	JOINTS 1 Brace at Jt(s): 16, 10, 12, 18, 21, 24, 26

REACTIONS. All bearings 6-3-8 except (jt=length) 2=0-3-8, 33=0-3-8.
 (lb) - Max Horz 2=-235(LC 13)
 Max Uplift All uplift 100 lb or less at joint(s) 31 except 2=-383(LC 12), 32=-937(LC 13)
 Max Grav All reactions 250 lb or less at joint(s) 29 except 2=1999(LC 2), 31=343(LC 13), 32=1628(LC 2), 33=460(LC 18)

FORCES. (lb) - Max. Comp./Max. Ten. - All forces 250 (lb) or less except when shown.
 TOP CHORD 2-3=-3362/330, 3-4=-3637/622, 4-6=-2385/446, 6-7=-470/248, 7-9=-448/208, 9-11=-456/166, 11-14=-476/133, 14-17=-508/108, 17-19=-473/16, 19-22=-500/0, 22-23=-523/0, 23-25=-527/0, 25-27=-609/0, 27-28=-440/147, 28-29=-317/84, 6-8=-1868/527, 8-10=-1747/502, 10-12=-1791/520, 12-15=-1813/530, 15-16=-1828/533, 16-18=-2582/558, 18-21=-2594/560, 21-24=-2616/571, 24-26=-2659/586, 26-32=-2621/579
 BOT CHORD 2-39=-526/3071, 38-39=-633/3212, 36-38=-633/3212, 34-36=-281/2749, 33-34=-281/2749, 32-33=-281/2749, 31-32=-88/312, 29-31=-88/312
 WEBS 3-39=-548/357, 4-38=0/754, 4-36=-1351/467, 6-36=-141/1425, 16-34=0/559, 16-36=-887/337, 7-8=-137/270, 27-32=-793/463, 16-17=-315/279

- NOTES-**
- Unbalanced roof live loads have been considered for this design.
 - Wind: ASCE 7-16; Vult=130mph (3-second gust) Vasd=103mph; TC DL=6.0psf; BCDL=6.0psf; h=15ft; Cat. II; Exp C; Enclosed; Gable Roof; Common Truss; MWFRS (envelope) gable end zone and C-C Exterior(2E) 0-11-0 to 1-11-8, Interior(1) 1-11-8 to 23-5-8, Exterior(2R) 23-5-8 to 27-10-5, Interior(1) 27-10-5 to 46-8-2 zone; C-C for members and forces & MWFRS for reactions shown; Lumber DOL=1.60 plate grip DOL=1.60
 - Truss designed for wind loads in the plane of the truss only. For studs exposed to wind (normal to the face), see Standard Industry Gable End Details as applicable, or consult qualified building designer as per ANSI/TPI 1.
 - All plates are 2x4 MT20 unless otherwise indicated.
 - Gable studs spaced at 2-0-0 oc.
 - This truss has been designed for a 10.0 psf bottom chord live load nonconcurrent with any other live loads.
 - * This truss has been designed for a live load of 30.0psf on the bottom chord in all areas where a rectangle 3-6-0 tall by 2-0-0 wide will fit between the bottom chord and any other members, with BCDL = 10.0psf.



Job J0723-3614	Truss A1-GE	Truss Type GABLE	Qty 1	Ply 1	Lot 4 Jones Creek / Harnett Job Reference (optional)	I58361093
-------------------	----------------	---------------------	----------	----------	---	-----------

Comtech, Inc. Fayetteville, NC - 28314,

8.430 s Jan 6 2022 MiTek Industries, Inc. Mon May 15 15:23:54 2023 Page 2
ID:2GNsYO62BI49KgBFP3SlmayOXVO-RfC?PsB70Hq3NSgPqnL8w3uITXbGKWrCDoi7J4zJC?f

NOTES-

- 8) Provide mechanical connection (by others) of truss to bearing plate capable of withstanding 100 lb uplift at joint(s) 31 except (jt=lb) 2=383, 32=937.
- 9) This truss is designed in accordance with the 2018 International Residential Code sections R502.11.1 and R802.10.2 and referenced standard ANSI/TPI 1.
- 10) See Standard Industry Piggyback Truss Connection Detail for Connection to base truss as applicable, or consult qualified building designer.
- 11) Graphical purlin representation does not depict the size or the orientation of the purlin along the top and/or bottom chord.

WARNING - Verify design parameters and READ NOTES ON THIS AND INCLUDED MITEK REFERENCE PAGE MII-7473 rev. 5/19/2020 BEFORE USE.

Design valid for use only with MiTek® connectors. This design is based only upon parameters shown, and is for an individual building component, not a truss system. Before use, the building designer must verify the applicability of design parameters and properly incorporate this design into the overall building design. Bracing indicated is to prevent buckling of individual truss web and/or chord members only. Additional temporary and permanent bracing is always required for stability and to prevent collapse with possible personal injury and property damage. For general guidance regarding the fabrication, storage, delivery, erection and bracing of trusses and truss systems, see **ANSI/TPI1 Quality Criteria, DSB-89 and BCSI Building Component Safety Information** available from Truss Plate Institute, 2670 Crain Highway, Suite 203 Waldorf, MD 20601



818 Soundside Road
Edenton, NC 27932

Job J0723-3614	Truss A2	Truss Type Common	Qty 6	Ply 1	Lot 4 Jones Creek / Harnett	158361094
-------------------	-------------	----------------------	----------	----------	-----------------------------	-----------

Comtech, Inc. Fayetteville, NC - 28314,

8.430 s Jan 6 2022 MiTek Industries, Inc. Mon May 15 15:23:56 2023 Page 1

ID:2GNsYO62BI49KgBFP3SImayOXVO-RfC?PsB70Hq3NSgPqnL8w3ulTXbGKWrCDoi7J4zJC?f

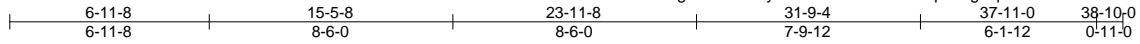

Scale = 1:80.4

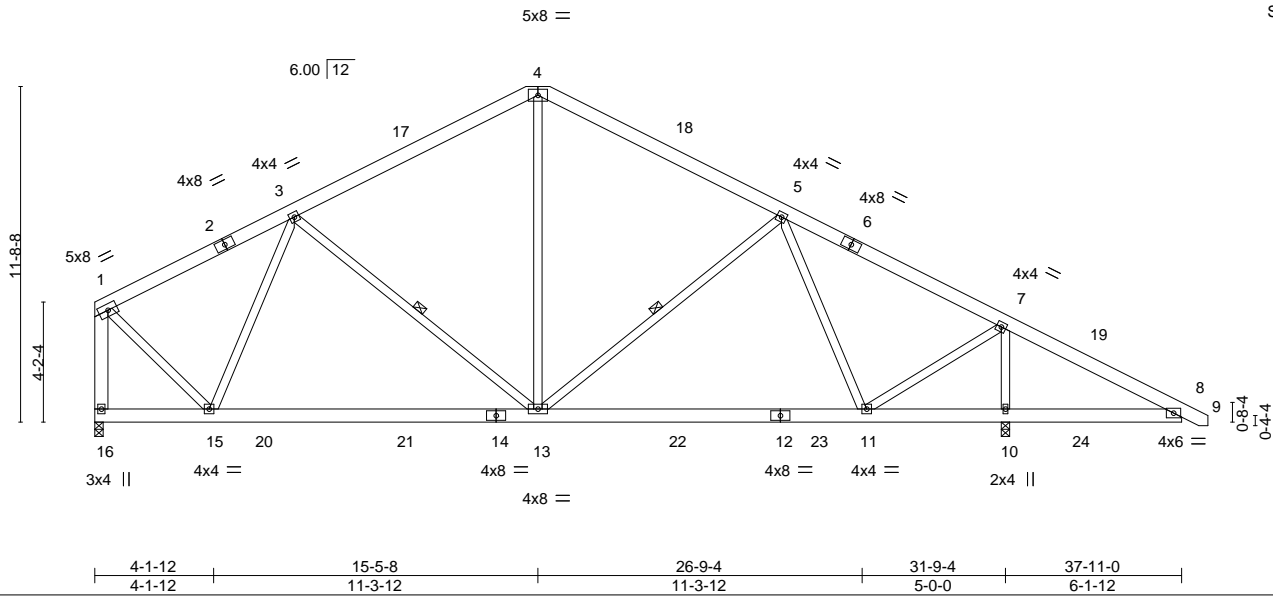

LOADING (psf)	SPACING-	2-0-0	CSI.	DEFL.	in (loc)	l/defl	L/d	PLATES	GRIP
TCLL 20.0	Plate Grip DOL	1.15	TC 0.28	Vert(LL)	-0.17 11-13	>999	360	MT20	244/190
TCDL 10.0	Lumber DOL	1.15	BC 0.57	Vert(CT)	-0.26 11-13	>999	240		
BCLL 0.0 *	Rep Stress Incr	YES	WB 0.62	Horz(CT)	0.02 10	n/a	n/a		
BCDL 10.0	Code IRC2018/TPI2014		Matrix-S	Wind(LL)	0.02 11-13	>999	240	Weight: 288 lb	FT = 20%

LUMBER-	BRACING-
TOP CHORD 2x6 SP No.1	TOP CHORD Structural wood sheathing directly applied or 6-0-0 oc purlins, except end verticals.
BOT CHORD 2x6 SP No.1	BOT CHORD Rigid ceiling directly applied or 6-0-0 oc bracing.
WEBS 2x4 SP No.2 *Except* 1-16: 2x6 SP No.1	WEBS 1 Row at midpt 3-13, 5-13

REACTIONS. (size) 16=0-3-8, 10=0-3-8
 Max Horz 16=220(LC 13)
 Max Uplift 16=69(LC 12), 10=132(LC 13)
 Max Grav 16=1435(LC 2), 10=2103(LC 2)

FORCES. (lb) - Max. Comp./Max. Ten. - All forces 250 (lb) or less except when shown.
 TOP CHORD 1-3=-1073/177, 3-4=-1247/307, 4-5=-1247/281, 5-7=-1089/78, 7-8=-610/604,
 1-16=-1479/217
 BOT CHORD 13-15=-54/1166, 11-13=0/1067, 10-11=-454/596, 8-10=-454/596
 WEBS 3-15=-551/195, 4-13=-1/655, 5-11=-612/391, 7-11=-362/1590, 1-15=-86/1262,
 7-10=-1942/650

- NOTES-**
- 1) Unbalanced roof live loads have been considered for this design.
 - 2) Wind: ASCE 7-16; Vult=130mph (3-second gust) Vasd=103mph; TCDL=6.0psf; BCDL=6.0psf; h=15ft; Cat. II; Exp C; Enclosed; MWFRS (envelope) and C-C Exterior(2E) 0-2-12 to 4-7-9, Interior(1) 4-7-9 to 15-5-8, Exterior(2R) 15-5-8 to 19-10-5, Interior(1) 19-10-5 to 38-8-2 zone; cantilever right exposed ;C-C for members and forces & MWFRS for reactions shown; Lumber DOL=1.60 plate grip DOL=1.60
 - 3) This truss has been designed for a 10.0 psf bottom chord live load nonconcurrent with any other live loads.
 - 4) * This truss has been designed for a live load of 30.0psf on the bottom chord in all areas where a rectangle 3-6-0 tall by 2-0-0 wide will fit between the bottom chord and any other members, with BCDL = 10.0psf.
 - 5) Provide mechanical connection (by others) of truss to bearing plate capable of withstanding 100 lb uplift at joint(s) 16 except (jt=lb) 10=132.
 - 6) This truss is designed in accordance with the 2018 International Residential Code sections R502.11.1 and R802.10.2 and referenced standard ANSI/TPI 1.



May 16, 2023

WARNING - Verify design parameters and READ NOTES ON THIS AND INCLUDED MITEK REFERENCE PAGE MII-7473 rev. 5/19/2020 BEFORE USE.
 Design valid for use only with MiTek® connectors. This design is based only upon parameters shown, and is for an individual building component, not a truss system. Before use, the building designer must verify the applicability of design parameters and properly incorporate this design into the overall building design. Bracing indicated is to prevent buckling of individual truss web and/or chord members only. Additional temporary and permanent bracing is always required for stability and to prevent collapse with possible personal injury and property damage. For general guidance regarding the fabrication, storage, delivery, erection and bracing of trusses and truss systems, see **ANSI/TPI1 Quality Criteria, DSB-89 and BCSI Building Component Safety Information** available from Truss Plate Institute, 2670 Crain Highway, Suite 203 Waldorf, MD 20601

ENGINEERING BY
TRENCO
 A MiTek Affiliate

818 Soundside Road
 Edenton, NC 27932

Job J0723-3614	Truss A3	Truss Type Common	Qty 3	Ply 1	Lot 4 Jones Creek / Harnett Job Reference (optional)	158361095
-------------------	-------------	----------------------	----------	----------	---	-----------

Comtech, Inc. Fayetteville, NC - 28314,

8.430 s Jan 6 2022 MiTek Industries, Inc. Mon May 15 15:23:57 2023 Page 1

ID:2GNsYO62BI49KgBFP3SlmayOXVO-RfC?PsB70Hq3NSgPqnL8w3ulTXbGKWrcDoi7J4zJC?f

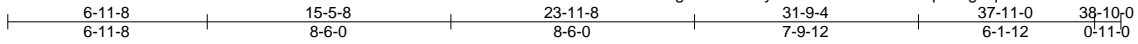

5x8 =

Scale = 1:80.4

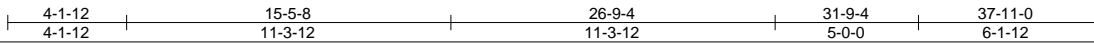
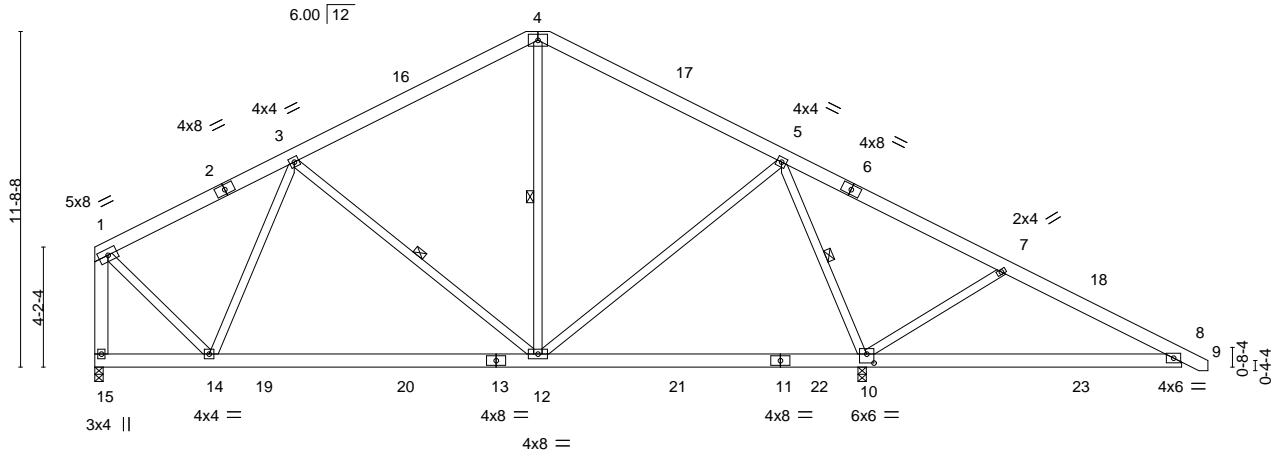

Plate Offsets (X, Y)--	[10:0-3-0,0-3-12]
------------------------	-------------------

LOADING (psf)	SPACING-	2-0-0	CSI.	DEFL.	in (loc)	l/defl	L/d	PLATES	GRIP
TCLL 20.0	Plate Grip DOL	1.15	TC 0.40	Vert(LL)	-0.15 12-14	>999	360	MT20	244/190
TCDL 10.0	Lumber DOL	1.15	BC 0.52	Vert(CT)	-0.24 12-14	>999	240		
BCLL 0.0 *	Rep Stress Incr	YES	WB 0.93	Horz(CT)	0.01 10	n/a	n/a		
BCDL 10.0	Code IRC2018/TPI2014		Matrix-S	Wind(LL)	-0.11 10-12	>999	240	Weight: 284 lb	FT = 20%

LUMBER-	BRACING-
TOP CHORD 2x6 SP No.1	TOP CHORD Structural wood sheathing directly applied or 6-0-0 oc purlins, except end verticals.
BOT CHORD 2x6 SP No.1	BOT CHORD Rigid ceiling directly applied or 6-0-0 oc bracing, Except:
WEBS 2x4 SP No.2 *Except* 1-15: 2x6 SP No.1	WEBS 1 Row at midpt 3-12, 4-12, 5-10

REACTIONS.	(size) 15=0-3-8, 10=0-3-8
	Max Horz 15=-220(LC 13)
	Max Uplift 15=-72(LC 12), 10=-157(LC 13)
	Max Grav 15=1053(LC 27), 10=2490(LC 2)

FORCES.	(lb) - Max. Comp./Max. Ten. - All forces 250 (lb) or less except when shown.
TOP CHORD	1-3=-792/70, 3-4=-695/140, 4-5=-678/163, 5-7=-1016/1127, 7-8=-859/701, 1-15=-1105/64
BOT CHORD	12-14=-56/827, 10-12=-298/745, 8-10=-533/793
WEBS	3-14=-308/119, 3-12=-316/302, 4-12=-117/295, 5-12=-433/917, 5-10=-1860/978, 7-10=-496/380, 1-14=0/917

- NOTES-**
- 1) Unbalanced roof live loads have been considered for this design.
 - 2) Wind: ASCE 7-16; Vult=130mph (3-second gust) Vasd=103mph; TCDL=6.0psf; BCDL=6.0psf; h=15ft; Cat. II; Exp C; Enclosed; MWFRS (envelope) and C-C Exterior(2E) 0-2-12 to 4-7-9, Interior(1) 4-7-9 to 15-5-8, Exterior(2R) 15-5-8 to 19-10-5, Interior(1) 19-10-5 to 38-8-2 zone; cantilever right exposed ;C-C for members and forces & MWFRS for reactions shown; Lumber DOL=1.60 plate grip DOL=1.60
 - 3) This truss has been designed for a 10.0 psf bottom chord live load nonconcurrent with any other live loads.
 - 4) * This truss has been designed for a live load of 30.0psf on the bottom chord in all areas where a rectangle 3-6-0 tall by 2-0-0 wide will fit between the bottom chord and any other members, with BCDL = 10.0psf.
 - 5) Provide mechanical connection (by others) of truss to bearing plate capable of withstanding 100 lb uplift at joint(s) 15 except (jt=lb) 10=157.
 - 6) This truss is designed in accordance with the 2018 International Residential Code sections R502.11.1 and R802.10.2 and referenced standard ANSI/TPI 1.

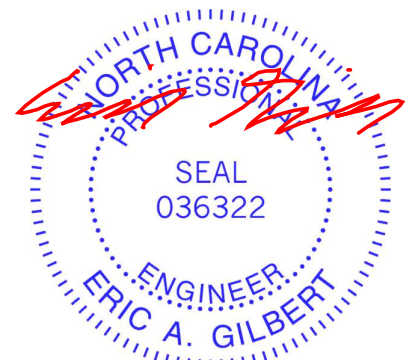

May 16, 2023

<p>WARNING - Verify design parameters and READ NOTES ON THIS AND INCLUDED MITEK REFERENCE PAGE MII-7473 rev. 5/19/2020 BEFORE USE.</p> <p>Design valid for use only with MiTek® connectors. This design is based only upon parameters shown, and is for an individual building component, not a truss system. Before use, the building designer must verify the applicability of design parameters and properly incorporate this design into the overall building design. Bracing indicated is to prevent buckling of individual truss web and/or chord members only. Additional temporary and permanent bracing is always required for stability and to prevent collapse with possible personal injury and property damage. For general guidance regarding the fabrication, storage, delivery, erection and bracing of trusses and truss systems, see ANSI/TPI1 Quality Criteria, DSB-89 and BCSI Building Component Safety Information available from Truss Plate Institute, 2670 Crain Highway, Suite 203 Waldorf, MD 20601</p>	<p>818 Soundside Road Edenton, NC 27932</p>
--	---

Job J0723-3614	Truss A4	Truss Type COMMON	Qty 1	Ply 1	Lot 4 Jones Creek / Harnett Job Reference (optional)	158361096
-------------------	-------------	----------------------	----------	----------	---	-----------

Comtech, Inc. Fayetteville, NC - 28314,

8.430 s Jan 6 2022 MiTek Industries, Inc. Mon May 15 15:23:58 2023 Page 1

ID:2GNsYO62BI49KgBFP3SImayOXVO-RfC?PsB70Hq3NSgPqnL8w3uITXbGKWrCDoi7J4zJC?f

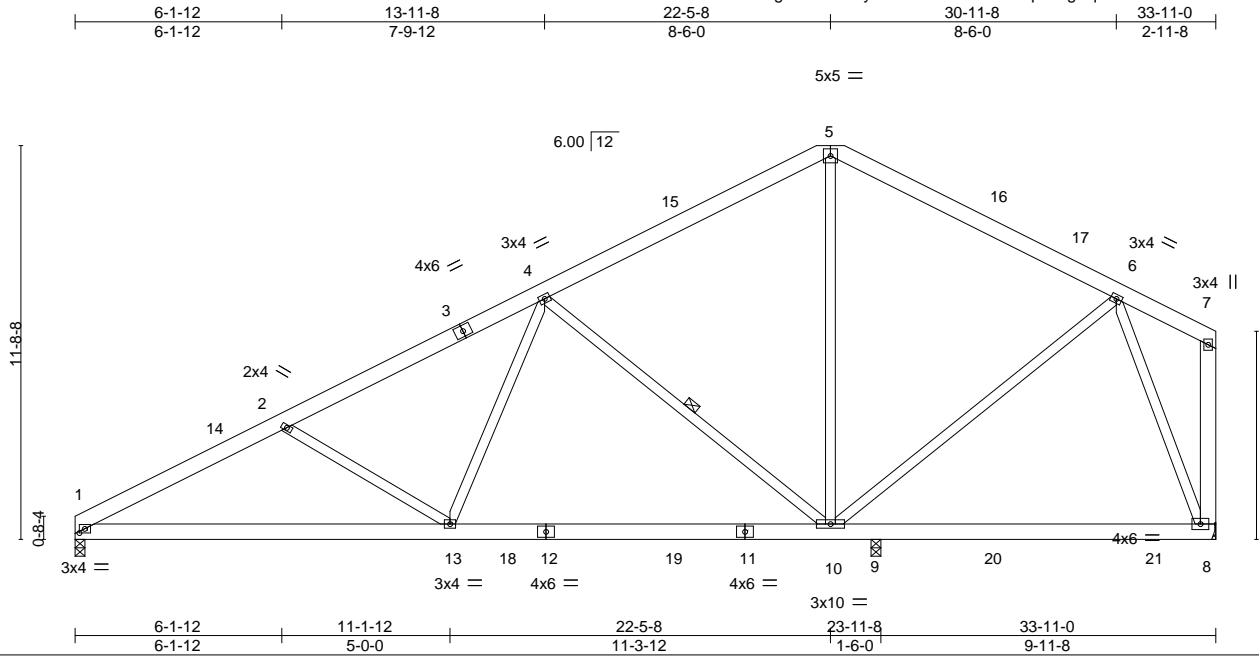

Plate Offsets (X, Y)--	[1:0-1-14,0-1-8]
------------------------	------------------

LOADING (psf)	SPACING- 2-0-0	CSI.	DEFL. in (loc) l/defl L/d	PLATES	GRIP
TCLL 20.0	Plate Grip DOL 1.15	TC 0.28	Vert(LL) -0.21 10-13 >999 360	MT20	244/190
TCDL 10.0	Lumber DOL 1.15	BC 0.63	Vert(CT) -0.34 10-13 >847 240		
BCLL 0.0 *	Rep Stress Incr YES	WB 1.00	Horz(CT) 0.04 8 n/a n/a		
BCDL 10.0	Code IRC2018/TPI2014	Matrix-S	Wind(LL) 0.07 10-13 >999 240	Weight: 259 lb	FT = 20%

LUMBER-	BRACING-
TOP CHORD 2x6 SP No.1	TOP CHORD Structural wood sheathing directly applied or 5-0-15 oc purlins, except end verticals.
BOT CHORD 2x6 SP No.1	BOT CHORD Rigid ceiling directly applied or 10-0-0 oc bracing.
WEBS 2x4 SP No.2 *Except* 7-8: 2x6 SP No.1	WEBS 1 Row at midpt 4-10

REACTIONS. (size) 1=0-3-8, 8=Mechanical, 9=0-3-8
 Max Horz 1=257(LC 12)
 Max Uplift 1=94(LC 12), 8=-89(LC 13)
 Max Grav 1=1313(LC 19), 8=1102(LC 2), 9=732(LC 2)

FORCES. (lb) - Max. Comp./Max. Ten. - All forces 250 (lb) or less except when shown.
 TOP CHORD 1-2=-2242/475, 2-4=-1969/393, 4-5=-823/331, 5-6=-821/332
 BOT CHORD 1-13=-542/1997, 10-13=-363/1447, 9-10=-129/371, 8-9=-129/371
 WEBS 2-13=-372/248, 4-13=0/788, 4-10=-1033/305, 5-10=-21/284, 6-10=-18/400,
 6-8=-1020/391

- NOTES-**
- Unbalanced roof live loads have been considered for this design.
 - Wind: ASCE 7-16; Vult=130mph (3-second gust) Vasd=103mph; TCDL=6.0psf; BCDL=6.0psf; h=15ft; Cat. II; Exp C; Enclosed; MWFRS (envelope) and C-C Exterior(2E) 0-1-12 to 4-6-9, Interior(1) 4-6-9 to 22-5-8, Exterior(2R) 22-5-8 to 26-10-5, Interior(1) 26-10-5 to 33-8-4 zone; C-C for members and forces & MWFRS for reactions shown; Lumber DOL=1.60 plate grip DOL=1.60
 - This truss has been designed for a 10.0 psf bottom chord live load nonconcurrent with any other live loads.
 - * This truss has been designed for a live load of 30.0psf on the bottom chord in all areas where a rectangle 3-6-0 tall by 2-0-0 wide will fit between the bottom chord and any other members, with BCDL = 10.0psf.
 - Refer to girder(s) for truss to truss connections.
 - Provide mechanical connection (by others) of truss to bearing plate capable of withstanding 100 lb uplift at joint(s) 1, 8.
 - This truss is designed in accordance with the 2018 International Residential Code sections R502.11.1 and R802.10.2 and referenced standard ANSI/TPI 1.



May 16, 2023

Job J0723-3614	Truss A6	Truss Type Common	Qty 11	Ply 1	Lot 4 Jones Creek / Harnett Job Reference (optional)	158361097
-------------------	-------------	----------------------	-----------	----------	---	-----------

Comtech, Inc. Fayetteville, NC - 28314,

8.430 s Jan 6 2022 MiTek Industries, Inc. Mon May 15 15:24:00 2023 Page 1

ID:2GNsYO62BI49KgBFP3SlmayOXVO-RfC?PsB70Hq3NSgPqnL8w3uITXbGKWrCDoi7J4zJC?f



5x5 =

Scale = 1:74.7

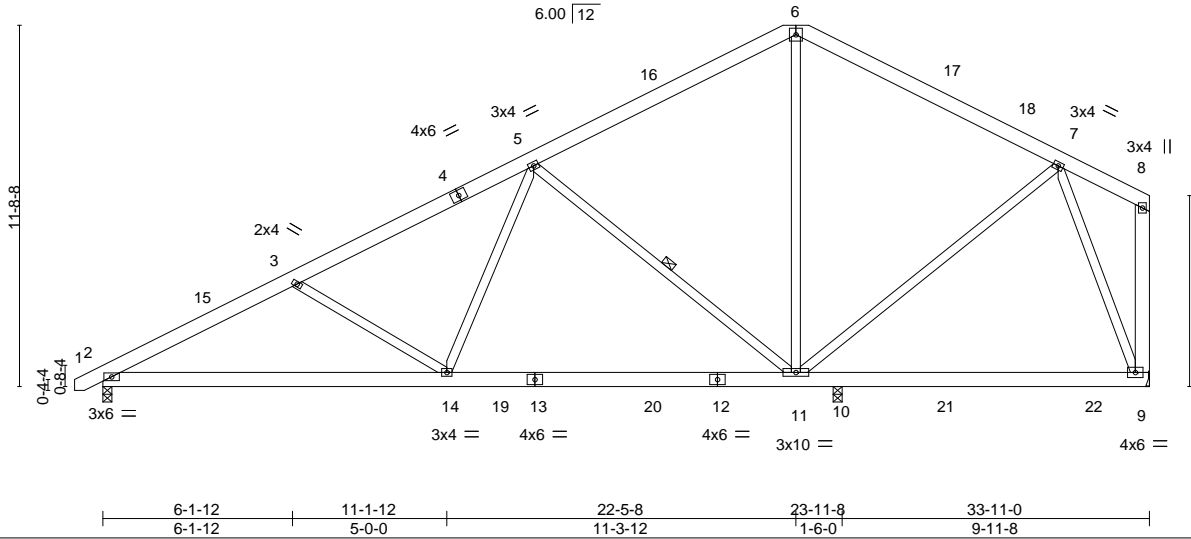

LOADING (psf)	SPACING-	2-0-0	CSI.	DEFL.	in (loc)	l/defl	L/d	PLATES	GRIP
TCLL 20.0	Plate Grip DOL	1.15	TC 0.28	Vert(LL)	-0.21 11-14	>999	360	MT20	244/190
TCDL 10.0	Lumber DOL	1.15	BC 0.63	Vert(CT)	-0.34 11-14	>845	240		
BCLL 0.0 *	Rep Stress Incr	YES	WB 1.00	Horz(CT)	0.04 9	n/a	n/a		
BCDL 10.0	Code IRC2018/TPI2014		Matrix-S	Wind(LL)	0.07 11-14	>999	240	Weight: 261 lb	FT = 20%

LUMBER-	BRACING-
TOP CHORD 2x6 SP No.1	TOP CHORD Structural wood sheathing directly applied or 5-1-2 oc purlins, except end verticals.
BOT CHORD 2x6 SP No.1	BOT CHORD Rigid ceiling directly applied or 10-0-0 oc bracing.
WEBS 2x4 SP No.2 *Except* 8-9: 2x6 SP No.1	WEBS 1 Row at midpt 5-11

REACTIONS. (size) 2=0-3-8, 9=Mechanical, 10=0-3-8
 Max Horz 2=261(LC 12)
 Max Uplift 2=-107(LC 12), 9=-89(LC 13)
 Max Grav 2=1357(LC 19), 9=1103(LC 2), 10=730(LC 2)

FORCES. (lb) - Max. Comp./Max. Ten. - All forces 250 (lb) or less except when shown.
 TOP CHORD 2-3=-2239/460, 3-5=-1967/385, 5-6=-824/330, 6-7=-821/331
 BOT CHORD 2-14=-537/1994, 11-14=-363/1446, 10-11=-128/371, 9-10=-128/371
 WEBS 3-14=-368/233, 5-14=0/785, 5-11=-1031/306, 6-11=-20/285, 7-11=-17/400,
 7-9=-1020/391

- NOTES-**
- 1) Unbalanced roof live loads have been considered for this design.
 - 2) Wind: ASCE 7-16; Vult=130mph (3-second gust) Vasd=103mph; TCCL=6.0psf; BCDL=6.0psf; h=15ft; Cat. II; Exp C; Enclosed; MWFRS (envelope) and C-C Exterior(2E) -0-9-2 to 3-7-11, Interior(1) 3-7-11 to 22-5-8, Exterior(2R) 22-5-8 to 26-10-5, Interior(1) 26-10-5 to 33-8-4 zone; C-C for members and forces & MWFRS for reactions shown; Lumber DOL=1.60 plate grip DOL=1.60
 - 3) This truss has been designed for a 10.0 psf bottom chord live load nonconcurrent with any other live loads.
 - 4) * This truss has been designed for a live load of 30.0psf on the bottom chord in all areas where a rectangle 3-6-0 tall by 2-0-0 wide will fit between the bottom chord and any other members, with BCDL = 10.0psf.
 - 5) Refer to girder(s) for truss to truss connections.
 - 6) Provide mechanical connection (by others) of truss to bearing plate capable of withstanding 100 lb uplift at joint(s) 9 except (jt=lb) 2=107.
 - 7) This truss is designed in accordance with the 2018 International Residential Code sections R502.11.1 and R802.10.2 and referenced standard ANSI/TPI 1.
 - 8) See Standard Industry Piggyback Truss Connection Detail for Connection to base truss as applicable, or consult qualified building designer.

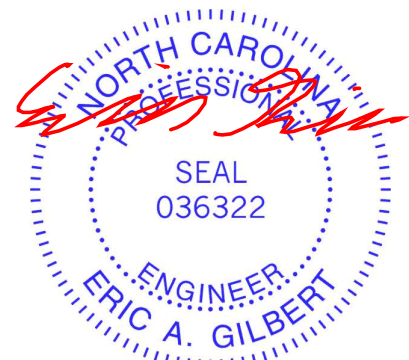

May 16, 2023

Job	Truss	Truss Type	Qty	Ply	Lot 4 Jones Creek / Harnett	158361098
J0723-3614	A7-GE	GABLE	1	1	Job Reference (optional)	

Comtech, Inc. Fayetteville, NC - 28314,

8.430 s Jan 6 2022 MiTek Industries, Inc. Mon May 15 15:24:02 2023 Page 1

ID:2GNsYO62BI49KgBFP3SlmayOXVO-RfC?PsB70Hq3NSgPqnL8w3uITXbGKWrCDoi7J4zJC?f



Scale = 1:74.1

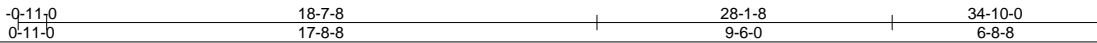
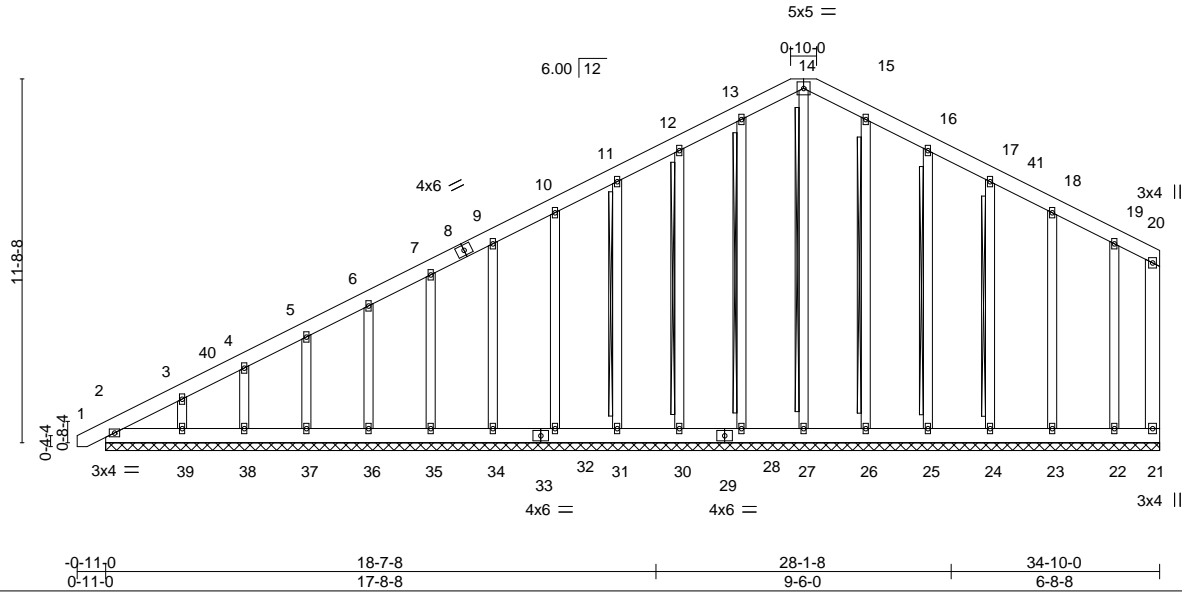

LOADING (psf)	SPACING-	2-0-0	CSI.	DEFL.	in (loc)	l/defl	L/d	PLATES	GRIP
TCLL 20.0	Plate Grip DOL	1.15	TC 0.05	Vert(LL)	-0.00	1	n/r	MT20	244/190
TCDL 10.0	Lumber DOL	1.15	BC 0.01	Vert(CT)	0.00	1	n/r		
BCLL 0.0 *	Rep Stress Incr	YES	WB 0.12	Horz(CT)	0.00	21	n/a		
BCDL 10.0	Code IRC2018/TPI2014		Matrix-S						
								Weight: 341 lb	FT = 20%

LUMBER-	BRACING-
TOP CHORD 2x6 SP No.1	TOP CHORD Structural wood sheathing directly applied or 6-0-0 oc purlins, except end verticals.
BOT CHORD 2x6 SP No.1	BOT CHORD Rigid ceiling directly applied or 10-0-0 oc bracing.
WEBS 2x6 SP No.1	WEBS T-Brace: 2x4 SPF No.2 - 14-27, 13-28, 12-30, 11-31, 15-26, 16-25, 17-24
OTHERS 2x4 SP No.2	Fasten (2X) T and I braces to narrow edge of web with 10d (0.131"x3") nails, 6in o.c., with 3in minimum end distance. Brace must cover 90% of web length.

REACTIONS. All bearings 33-11-0.
 (lb) - Max Horz 2=393(LC 12)
 Max Uplift All uplift 100 lb or less at joint(s) 2, 21, 28, 30, 31, 32, 34, 35, 36, 37, 38, 26, 25, 24, 23, 22 except 39=115(LC 12)
 Max Grav All reactions 250 lb or less at joint(s) 2, 21, 27, 28, 30, 31, 32, 34, 35, 36, 37, 38, 39, 26, 25, 24, 23, 22

FORCES. (lb) - Max. Comp./Max. Ten. - All forces 250 (lb) or less except when shown.
 TOP CHORD 2-3=-414/121, 3-4=-334/97, 4-5=-283/99, 12-13=-94/302, 13-14=-109/340, 14-15=-109/340, 15-16=-94/303

- NOTES-**
- Unbalanced roof live loads have been considered for this design.
 - Wind: ASCE 7-16; Vult=130mph (3-second gust) Vasd=103mph; TCDL=6.0psf; BCDL=6.0psf; h=15ft; Cat. II; Exp C; Enclosed; Gable Roof; Common Truss; MWFRS (envelope) gable end zone and C-C Corner(3E) -0-9-2 to 3-7-11, Exterior(2N) 3-7-11 to 22-5-8, Corner(3R) 22-5-8 to 26-10-5, Exterior(2N) 26-10-5 to 33-8-4 zone; C-C for members and forces & MWFRS for reactions shown; Lumber DOL=1.60 plate grip DOL=1.60
 - Truss designed for wind loads in the plane of the truss only. For studs exposed to wind (normal to the face), see Standard Industry Gable End Details as applicable, or consult qualified building designer as per ANSI/TPI 1.
 - All plates are 2x4 MT20 unless otherwise indicated.
 - Gable requires continuous bottom chord bearing.
 - Gable studs spaced at 2-0-0 oc.
 - This truss has been designed for a 10.0 psf bottom chord live load nonconcurrent with any other live loads.
 - * This truss has been designed for a live load of 30.0psf on the bottom chord in all areas where a rectangle 3-6-0 tall by 2-0-0 wide will fit between the bottom chord and any other members.
 - Provide mechanical connection (by others) of truss to bearing plate capable of withstanding 100 lb uplift at joint(s) 2, 21, 28, 30, 31, 32, 34, 35, 36, 37, 38, 26, 25, 24, 23, 22 except (jt=lb) 39=115.
 - This truss is designed in accordance with the 2018 International Residential Code sections R502.11.1 and R802.10.2 and referenced standard ANSI/TPI 1.
 - See Standard Industry Piggyback Truss Connection Detail for Connection to base truss as applicable, or consult qualified building designer.
 - Warning: Additional permanent and stability bracing for truss system (not part of this component design) is always required.

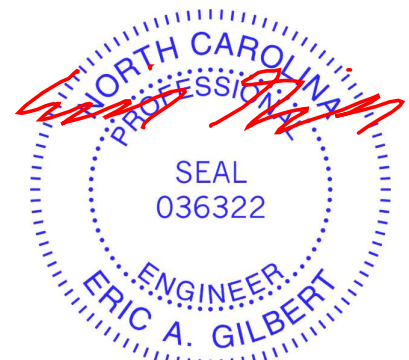

May 16, 2023

WARNING - Verify design parameters and READ NOTES ON THIS AND INCLUDED MITEK REFERENCE PAGE MII-7473 rev. 5/19/2020 BEFORE USE.

Design valid for use only with MiTek® connectors. This design is based only upon parameters shown, and is for an individual building component, not a truss system. Before use, the building designer must verify the applicability of design parameters and properly incorporate this design into the overall building design. Bracing indicated is to prevent buckling of individual truss web and/or chord members only. Additional temporary and permanent bracing is always required for stability and to prevent collapse with possible personal injury and property damage. For general guidance regarding the fabrication, storage, delivery, erection and bracing of trusses and truss systems, see **ANSI/TPI1 Quality Criteria, DSB-89 and BCSI Building Component Safety Information** available from Truss Plate Institute, 2670 Crain Highway, Suite 203 Waldorf, MD 20601

ENGINEERING BY
TRENCO
 A MiTek Affiliate

818 Soundside Road
 Edenton, NC 27932

Job	Truss	Truss Type	Qty	Ply	Lot 4 Jones Creek / Harnett	158361099
J0723-3614	B1-GE	ROOF SPECIAL SUPPORT	1	1		
Comtech, Inc. Fayetteville, NC - 28314,						Job Reference (optional)

8.430 s Jan 6 2022 MiTek Industries, Inc. Mon May 15 15:24:04 2023 Page 1
 ID:2GNsYO62BI49KgBFP3SlmayOXVO-RfC?PsB70Hq3NSgPqnL8w3ulTXbGKwrcDoi7J4zJC?f

-0-11-0 22-4-8 42-10-0 43-9-0
 0-11-0 21-5-8 20-5-8 0-11-0

Scale = 1:73.6

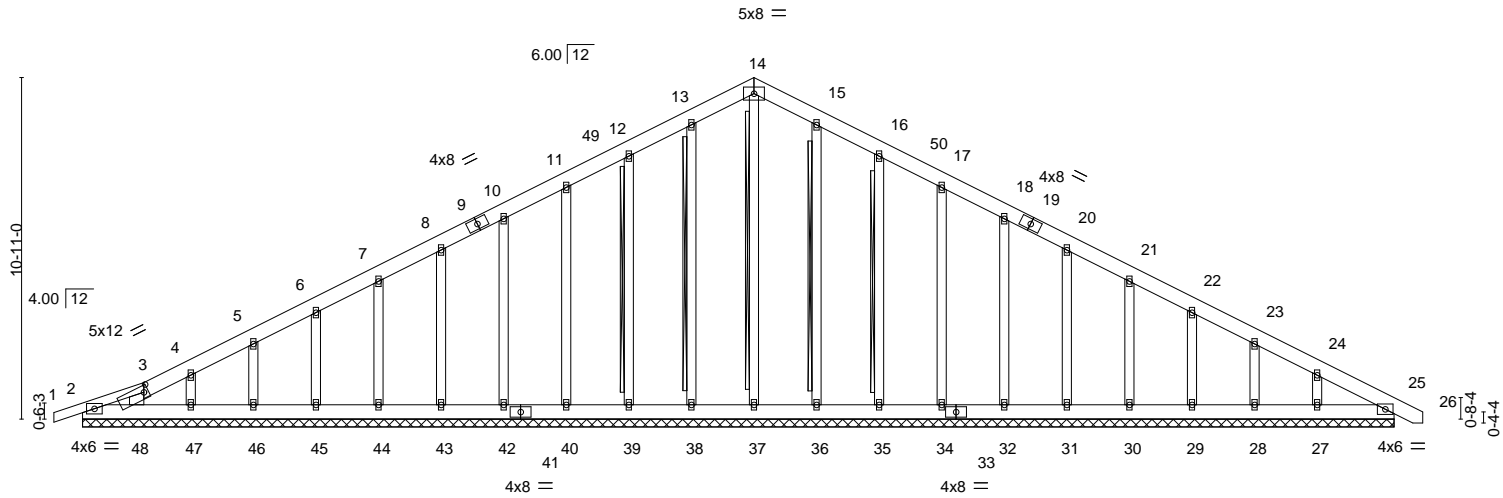

-0-11-0 42-10-0 43-9-0
 0-11-0 41-11-0 0-11-0

Plate Offsets (X, Y)-- [3:0-1-12,0-2-8]

LOADING (psf)	SPACING- 2-0-0	CSI.	DEFL. in (loc) l/defl L/d	PLATES	GRIP
TCLL 20.0	Plate Grip DOL 1.15	TC 0.05	Vert(LL) 0.00 25 n/r 120	MT20	244/190
TCDL 10.0	Lumber DOL 1.15	BC 0.02	Vert(CT) 0.00 25 n/r 120		
BCLL 0.0 *	Rep Stress Incr YES	WB 0.11	Horz(CT) 0.01 25 n/a n/a		
BCDL 10.0	Code IRC2018/TPI2014	Matrix-S			
				Weight: 360 lb	FT = 20%

LUMBER-	BRACING-
TOP CHORD 2x6 SP No.1 *Except* 1-3: 2x4 SP No.1	TOP CHORD Structural wood sheathing directly applied or 6-0-0 oc purlins. BOT CHORD Rigid ceiling directly applied or 10-0-0 oc bracing. Except: 6-0-0 oc bracing: 2-48.
BOT CHORD 2x6 SP No.1	WEBS T-Brace: 2x4 SPF No.2 - 14-37, 13-38, 12-39, 15-36, 16-35
WEBS 2x6 SP No.1	Fasten (2X) T and I braces to narrow edge of web with 10d (0.131"x3") nails, 6in o.c., with 3in minimum end distance. Brace must cover 90% of web length.
OTHERS 2x4 SP No.2	

REACTIONS. All bearings 41-11-0.
 (lb) - Max Horz 2--215(LC 17)
 Max Uplift All uplift 100 lb or less at joint(s) 38, 39, 40, 42, 43, 44, 45, 46, 47, 36, 35, 34, 32, 31, 30, 29, 28, 48, 2 except 27--101(LC 13)
 Max Grav All reactions 250 lb or less at joint(s) 25, 37, 38, 39, 40, 42, 43, 44, 45, 46, 47, 36, 35, 34, 32, 31, 30, 29, 28, 27, 48, 2

FORCES. (lb) - Max. Comp./Max. Ten. - All forces 250 (lb) or less except when shown.
 TOP CHORD 2-3--290/81, 3-4--255/88, 11-12--105/270, 12-13--128/324, 13-14--141/354, 14-15--141/339, 15-16--128/299

- NOTES-**
- 1) Unbalanced roof live loads have been considered for this design.
 - 2) Wind: ASCE 7-16; Vult=130mph (3-second gust) Vasd=103mph; TCDL=6.0psf; BCDL=6.0psf; h=15ft; Cat. II; Exp C; Enclosed; Gable Roof; Common Truss; MWFRS (envelope) gable end zone and C-C Corner(3E) -0-11-0 to 1-11-8, Exterior(2N) 1-11-8 to 21-5-8, Corner(3R) 21-5-8 to 25-10-5, Exterior(2N) 25-10-5 to 42-8-2 zone;C-C for members and forces & MWFRS for reactions shown; Lumber DOL=1.60 plate grip DOL=1.60
 - 3) Truss designed for wind loads in the plane of the truss only. For studs exposed to wind (normal to the face), see Standard Industry Gable End Details as applicable, or consult qualified building designer as per ANSI/TPI 1.
 - 4) All plates are 2x4 MT20 unless otherwise indicated.
 - 5) Gable requires continuous bottom chord bearing.
 - 6) Gable studs spaced at 2-0-0 oc.
 - 7) This truss has been designed for a 10.0 psf bottom chord live load nonconcurrent with any other live loads.
 - 8) * This truss has been designed for a live load of 30.0psf on the bottom chord in all areas where a rectangle 3-6-0 tall by 2-0-0 wide will fit between the bottom chord and any other members.
 - 9) Provide mechanical connection (by others) of truss to bearing plate capable of withstanding 100 lb uplift at joint(s) 38, 39, 40, 42, 43, 44, 45, 46, 47, 36, 35, 34, 32, 31, 30, 29, 28, 48, 2 except (jt=) 27=101.
 - 10) This truss is designed in accordance with the 2018 International Residential Code sections R502.11.1 and R802.10.2 and referenced standard ANSI/TPI 1.
 - 11) See Standard Industry Piggyback Truss Connection Detail for Connection to base truss as applicable, or consult qualified building designer.
 - 12) Warning: Additional permanent and stability bracing for truss system (not part of this component design) is always required.

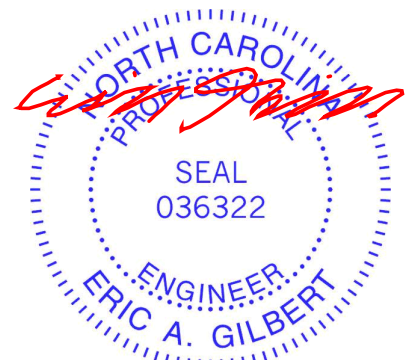

May 16, 2023

WARNING - Verify design parameters and READ NOTES ON THIS AND INCLUDED MITEK REFERENCE PAGE MII-7473 rev. 5/19/2020 BEFORE USE.
 Design valid for use only with MiTek® connectors. This design is based only upon parameters shown, and is for an individual building component, not a truss system. Before use, the building designer must verify the applicability of design parameters and properly incorporate this design into the overall building design. Bracing indicated is to prevent buckling of individual truss web and/or chord members only. Additional temporary and permanent bracing is always required for stability and to prevent collapse with possible personal injury and property damage. For general guidance regarding the fabrication, storage, delivery, erection and bracing of trusses and truss systems, see **ANSI/TPI1 Quality Criteria, DSB-89 and BCSI Building Component Safety Information** available from Truss Plate Institute, 2670 Crain Highway, Suite 203 Waldorf, MD 20601

ENGINEERING BY
TRENCO
 A MiTek Affiliate
 818 Soundside Road
 Edenton, NC 27932

Job J0723-3614	Truss B2	Truss Type Roof Special	Qty 6	Ply 1	Lot 4 Jones Creek / Harnett Job Reference (optional)	158361100
-------------------	-------------	----------------------------	----------	----------	---	-----------

Comtech, Inc. Fayetteville, NC - 28314,

8.430 s Jan 6 2022 MiTek Industries, Inc. Mon May 15 15:24:06 2023 Page 1

ID:2GNsYO62BI49KgBFP3SlmayOXVO-RfC?PsB70Hq3NSgPqnL8w3ulTXbGKwrcDoi7J4zJC?f

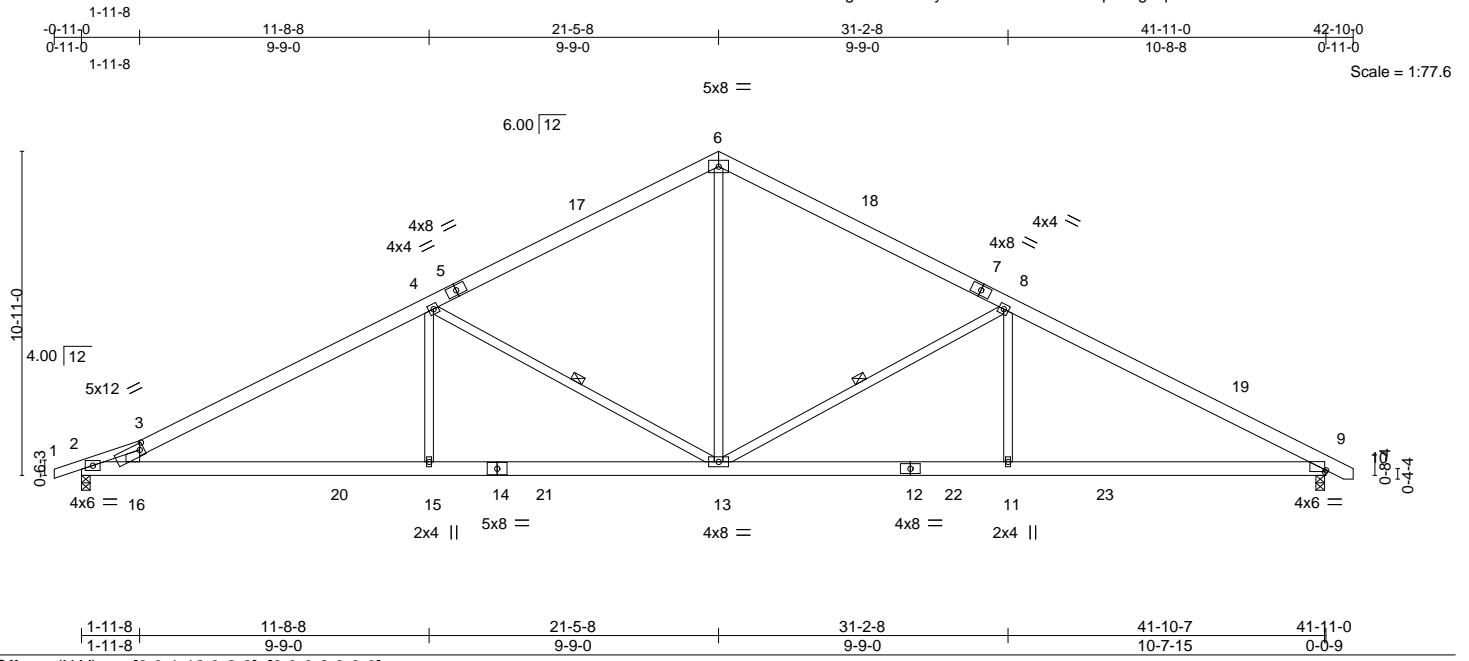

LOADING (psf)	SPACING-	2-0-0	CSI.	DEFL.	in (loc)	l/defl	L/d	PLATES	GRIP
TCLL 20.0	Plate Grip DOL	1.15	TC 0.92	Vert(LL)	-0.31 15-16	>999	360	MT20	244/190
TCDL 10.0	Lumber DOL	1.15	BC 0.69	Vert(CT)	-0.56 15-16	>895	240		
BCLL 0.0 *	Rep Stress Incr	YES	WB 0.81	Horz(CT)	0.11 9	n/a	n/a		
BCDL 10.0	Code IRC2018/TPI2014		Matrix-S	Wind(LL)	0.17 15-16	>999	240	Weight: 273 lb	FT = 20%

LUMBER-	BRACING-
TOP CHORD 2x6 SP No.1 *Except* 1-3: 2x4 SP No.1	TOP CHORD Structural wood sheathing directly applied or 2-2-0 oc purlins.
BOT CHORD 2x6 SP No.1 *Except* 2-14: 2x6 SP 2400F 2.0E	BOT CHORD Rigid ceiling directly applied or 9-9-13 oc bracing.
WEBS 2x4 SP No.2 *Except* 3-16: 2x6 SP No.1	WEBS 1 Row at midpt 4-13, 8-13

REACTIONS. (size) 2=0-3-8, 9=0-3-8
 Max Horz 2=139(LC 11)
 Max Uplift 2=-119(LC 12), 9=-110(LC 13)
 Max Grav 2=1998(LC 2), 9=1999(LC 2)

FORCES. (lb) - Max. Comp./Max. Ten. - All forces 250 (lb) or less except when shown.
 TOP CHORD 2-3=-3364/579, 3-4=-3638/869, 4-6=-2348/712, 6-8=-2346/714, 8-9=-3473/826
 BOT CHORD 2-16=-531/3116, 15-16=-634/3259, 13-15=-634/3259, 11-13=-577/3005, 9-11=-577/3005
 WEBS 3-16=-546/358, 4-15=0/762, 4-13=-1450/466, 6-13=-301/1574, 8-13=-1214/414,
 8-11=0/679

- NOTES-**
- Unbalanced roof live loads have been considered for this design.
 - Wind: ASCE 7-16; Vult=130mph (3-second gust) Vasd=103mph; TCDL=6.0psf; BCDL=6.0psf; h=15ft; Cat. II; Exp C; Enclosed; MWFRS (envelope) and C-C Exterior(2E) -0-11-0 to 1-11-8, Interior(1) 1-11-8 to 21-5-8, Exterior(2R) 21-5-8 to 25-10-5, Interior(1) 25-10-5 to 42-8-2 zone; C-C for members and forces & MWFRS for reactions shown; Lumber DOL=1.60 plate grip DOL=1.60
 - This truss has been designed for a 10.0 psf bottom chord live load nonconcurrent with any other live loads.
 - * This truss has been designed for a live load of 30.0psf on the bottom chord in all areas where a rectangle 3-6-0 tall by 2-0-0 wide will fit between the bottom chord and any other members, with BCDL = 10.0psf.
 - Provide mechanical connection (by others) of truss to bearing plate capable of withstanding 100 lb uplift at joint(s) except (jt=lb) 2=119, 9=110.
 - This truss is designed in accordance with the 2018 International Residential Code sections R502.11.1 and R802.10.2 and referenced standard ANSI/TPI 1.
 - See Standard Industry Piggyback Truss Connection Detail for Connection to base truss as applicable, or consult qualified building designer.

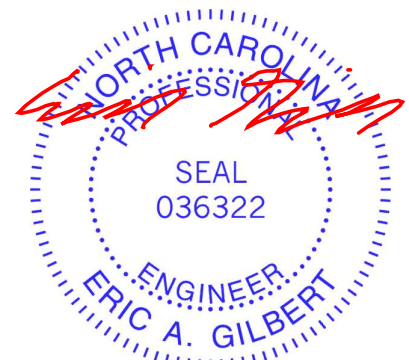

May 16, 2023

WARNING - Verify design parameters and READ NOTES ON THIS AND INCLUDED MITEK REFERENCE PAGE MII-7473 rev. 5/19/2020 BEFORE USE.
 Design valid for use only with MiTek® connectors. This design is based only upon parameters shown, and is for an individual building component, not a truss system. Before use, the building designer must verify the applicability of design parameters and properly incorporate this design into the overall building design. Bracing indicated is to prevent buckling of individual truss web and/or chord members only. Additional temporary and permanent bracing is always required for stability and to prevent collapse with possible personal injury and property damage. For general guidance regarding the fabrication, storage, delivery, erection and bracing of trusses and truss systems, see **ANSI/TPI1 Quality Criteria, DSB-89 and BCSI Building Component Safety Information** available from Truss Plate Institute, 2670 Crain Highway, Suite 203 Waldorf, MD 20601

ENGINEERING BY
TRENCO
 A MiTek Affiliate
 818 Soundside Road
 Edenton, NC 27932

Job J0723-3614	Truss D1-GE	Truss Type COMMON SUPPORTED GAB	Qty 1	Ply 1	Lot 4 Jones Creek / Harnett Job Reference (optional)	158361101
-------------------	----------------	------------------------------------	----------	----------	---	-----------

Comtech, Inc. Fayetteville, NC - 28314,

8.430 s Jan 6 2022 MiTek Industries, Inc. Mon May 15 15:24:08 2023 Page 1
ID:2GNsYO62BI49KgBFP3SlmayOXVO-RfC?PsB70Hq3NSgPqnL8w3ulTXbGKWrCDoi7J4zJC?f



Scale = 1:68.0

Plate Offsets (X,Y)--	[22:0-4-0,0-4-8]								
LOADING (psf)	SPACING-	2-0-0	CSI.	DEFL.	in (loc)	l/defl	L/d	PLATES	GRIP
TCLL 20.0	Plate Grip DOL	1.15	TC 0.05	Vert(LL)	0.00	16	n/r	MT20	244/190
TCDL 10.0	Lumber DOL	1.15	BC 0.03	Vert(CT)	0.00	16	n/r		
BCLL 0.0 *	Rep Stress Incr	YES	WB 0.12	Horz(CT)	0.01	16	n/a		
BCDL 10.0	Code IRC2018/TPI2014		Matrix-S						
								Weight: 226 lb	FT = 20%

LUMBER-
TOP CHORD 2x6 SP No.1
BOT CHORD 2x6 SP No.1
OTHERS 2x4 SP No.2
WEDGE
Left: 2x4 SP No.2 , Right: 2x4 SP No.2

BRACING-
TOP CHORD Structural wood sheathing directly applied or 6-0-0 oc purlins.
BOT CHORD Rigid ceiling directly applied or 10-0-0 oc bracing.
WEBS T-Brace: 2x4 SPF No.2 - 9-23, 8-24, 10-22
Fasten (2X) T and I braces to narrow edge of web with 10d (0.131"x3") nails, 6in o.c., with 3in minimum end distance.
Brace must cover 90% of web length.

REACTIONS. All bearings 23-11-0.
(lb) - Max Horz 2=318(LC 11)
Max Uplift All uplift 100 lb or less at joint(s) 24, 22, 16 except 2=114(LC 10), 25=124(LC 12), 26=110(LC 12), 27=109(LC 12), 28=196(LC 12), 21=127(LC 13), 20=110(LC 13), 19=109(LC 13), 18=186(LC 13)
Max Grav All reactions 250 lb or less at joint(s) 23, 24, 25, 26, 27, 28, 22, 21, 20, 19, 18, 16 except 2=256(LC 12)

FORCES. (lb) - Max. Comp./Max. Ten. - All forces 250 (lb) or less except when shown.
TOP CHORD 2-3=-404/264, 8-9=-163/254, 9-10=-163/254, 15-16=-343/174
BOT CHORD 2-28=-127/283, 27-28=-127/283, 26-27=-127/283, 25-26=-127/283, 24-25=-127/283, 23-24=-127/283, 22-23=-127/283, 21-22=-127/283, 20-21=-127/283, 19-20=-127/283, 18-19=-127/283, 16-18=-127/283

- NOTES-**
- Unbalanced roof live loads have been considered for this design.
 - Wind: ASCE 7-16; Vult=130mph (3-second gust) Vasd=103mph; TCDL=6.0psf; BCDL=6.0psf; h=15ft; Cat. II; Exp C; Enclosed; Gable Roof; Common Truss; MWFRS (envelope) gable end zone and C-C Corner(3E) -0-9-4 to 3-7-9, Exterior(2N) 3-7-9 to 11-11-8, Corner(3R) 11-11-8 to 16-4-5, Exterior(2N) 16-4-5 to 24-8-4 zone;C-C for members and forces & MWFRS for reactions shown; Lumber DOL=1.60 plate grip DOL=1.60
 - Truss designed for wind loads in the plane of the truss only. For studs exposed to wind (normal to the face), see Standard Industry Gable End Details as applicable, or consult qualified building designer as per ANSI/TPI 1.
 - All plates are 2x4 MT20 unless otherwise indicated.
 - Gable requires continuous bottom chord bearing.
 - Gable studs spaced at 2-0-0 oc.
 - This truss has been designed for a 10.0 psf bottom chord live load nonconcurrent with any other live loads.
 - * This truss has been designed for a live load of 30.0psf on the bottom chord in all areas where a rectangle 3-6-0 tall by 2-0-0 wide will fit between the bottom chord and any other members.
 - Provide mechanical connection (by others) of truss to bearing plate capable of withstanding 100 lb uplift at joint(s) 24, 22, 16 except (jt=lb) 2=114, 25=124, 26=110, 27=109, 28=196, 21=127, 20=110, 19=109, 18=186.
 - This truss is designed in accordance with the 2018 International Residential Code sections R502.11.1 and R802.10.2 and referenced standard ANSI/TPI 1.
 - See Standard Industry Piggyback Truss Connection Detail for Connection to base truss as applicable, or consult qualified building designer.
 - Warning: Additional permanent and stability bracing for truss system (not part of this component design) is always required.

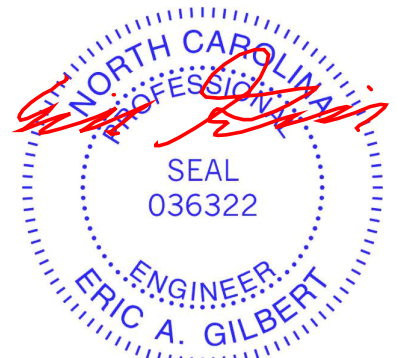

May 16, 2023

WARNING - Verify design parameters and READ NOTES ON THIS AND INCLUDED MITEK REFERENCE PAGE MII-7473 rev. 5/19/2020 BEFORE USE.
Design valid for use only with MiTek® connectors. This design is based only upon parameters shown, and is for an individual building component, not a truss system. Before use, the building designer must verify the applicability of design parameters and properly incorporate this design into the overall building design. Bracing indicated is to prevent buckling of individual truss web and/or chord members only. Additional temporary and permanent bracing is always required for stability and to prevent collapse with possible personal injury and property damage. For general guidance regarding the fabrication, storage, delivery, erection and bracing of trusses and truss systems, see **ANSI/TPI1 Quality Criteria, DSB-89 and BCSI Building Component Safety Information** available from Truss Plate Institute, 2670 Crain Highway, Suite 203 Waldorf, MD 20601



818 Soundside Road
Edenton, NC 27932

Job J0723-3614	Truss D2	Truss Type COMMON	Qty 5	Ply 1	Lot 4 Jones Creek / Harnett I58361102
-------------------	-------------	----------------------	----------	----------	--

Comtech, Inc. Fayetteville, NC - 28314,

8,430 s Jan 6 2022 MiTek Industries, Inc. Mon May 15 15:24:09 2023 Page 1

ID:2GNsYO62BI49KgBFP3SlmayOXVO-RfC?PsB70Hq3NSgPqnL8w3uITXbGKWrCDoi7J4zJC?f

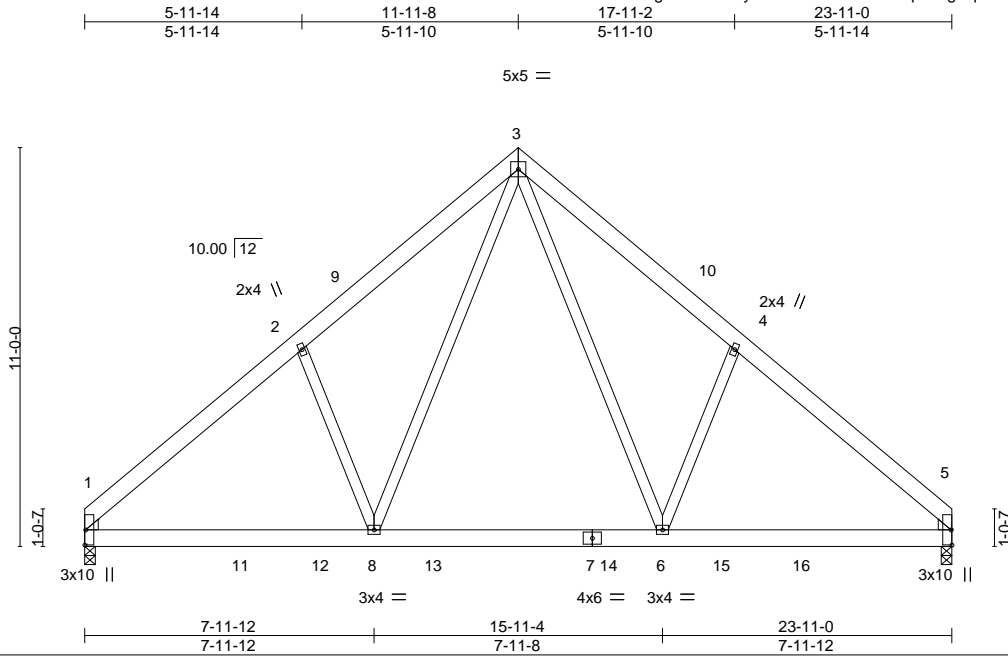

Scale: 3/16"=1'

LOADING (psf)	SPACING-	2-0-0	CSI.	DEFL.	in (loc)	l/defl	L/d	PLATES	GRIP
TCLL 20.0	Plate Grip DOL	1.15	TC 0.22	Vert(LL)	-0.06 6-8	>999	360	MT20	244/190
TCDL 10.0	Lumber DOL	1.15	BC 0.33	Vert(CT)	-0.08 6-8	>999	240		
BCLL 0.0 *	Rep Stress Incr	YES	WB 0.40	Horz(CT)	0.02 5	n/a	n/a		
BCDL 10.0	Code IRC2018/TPI2014		Matrix-S	Wind(LL)	0.02 1-8	>999	240		
								Weight: 179 lb	FT = 20%

LUMBER-
 TOP CHORD 2x6 SP No.1
 BOT CHORD 2x6 SP No.1
 WEBS 2x4 SP No.2
 WEDGE
 Left: 2x4 SP No.2 , Right: 2x4 SP No.2

BRACING-
 TOP CHORD Structural wood sheathing directly applied or 6-0-0 oc purlins.
 BOT CHORD Rigid ceiling directly applied or 10-0-0 oc bracing.

REACTIONS. (size) 1=0-3-8, 5=0-3-8
 Max Horz 1=-251(LC 10)
 Max Uplift 1=-38(LC 12), 5=-38(LC 13)
 Max Grav 1=1177(LC 19), 5=1177(LC 20)

FORCES. (lb) - Max. Comp./Max. Ten. - All forces 250 (lb) or less except when shown.
 TOP CHORD 1-2=-1422/258, 2-3=-1326/397, 3-4=-1326/397, 4-5=-1421/258
 BOT CHORD 1-8=-99/1140, 6-8=0/762, 5-6=-82/1009
 WEBS 3-6=-184/762, 4-6=-300/287, 3-8=-184/761, 2-8=-300/287

- NOTES-**
- 1) Unbalanced roof live loads have been considered for this design.
 - 2) Wind: ASCE 7-16; Vult=130mph (3-second gust) Vasd=103mph; TCDL=6.0psf; BCDL=6.0psf; h=15ft; Cat. II; Exp C; Enclosed; MWFRS (envelope) and C-C Exterior(2E) 0-1-12 to 4-6-9, Interior(1) 4-6-9 to 11-11-8, Exterior(2R) 11-11-8 to 16-4-5, Interior(1) 16-4-5 to 23-9-4 zone; C-C for members and forces & MWFRS for reactions shown; Lumber DOL=1.60 plate grip DOL=1.60
 - 3) This truss has been designed for a 10.0 psf bottom chord live load nonconcurrent with any other live loads.
 - 4) * This truss has been designed for a live load of 30.0psf on the bottom chord in all areas where a rectangle 3-6-0 tall by 2-0-0 wide will fit between the bottom chord and any other members, with BCDL = 10.0psf.
 - 5) Provide mechanical connection (by others) of truss to bearing plate capable of withstanding 100 lb uplift at joint(s) 1, 5.
 - 6) This truss is designed in accordance with the 2018 International Residential Code sections R502.11.1 and R802.10.2 and referenced standard ANSI/TPI 1.

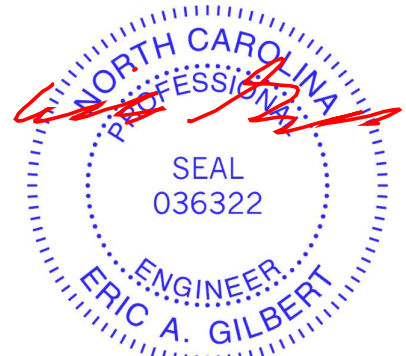

May 16, 2023

WARNING - Verify design parameters and READ NOTES ON THIS AND INCLUDED MITEK REFERENCE PAGE MII-7473 rev. 5/19/2020 BEFORE USE.

Design valid for use only with MiTek® connectors. This design is based only upon parameters shown, and is for an individual building component, not a truss system. Before use, the building designer must verify the applicability of design parameters and properly incorporate this design into the overall building design. Bracing indicated is to prevent buckling of individual truss web and/or chord members only. Additional temporary and permanent bracing is always required for stability and to prevent collapse with possible personal injury and property damage. For general guidance regarding the fabrication, storage, delivery, erection and bracing of trusses and truss systems, see

ANSI/TPI1 Quality Criteria, DSB-89 and BCSI Building Component

Safety Information available from Truss Plate Institute, 2670 Crain Highway, Suite 203 Waldorf, MD 20601



818 Soundside Road
 Edenton, NC 27932

Job J0723-3614	Truss D3	Truss Type COMMON GIRDER	Qty 1	Ply 2	Lot 4 Jones Creek / Harnett I58361103
-------------------	-------------	-----------------------------	----------	----------	--

Comtech, Inc. Fayetteville, NC - 28314,

8.430 s Jan 6 2022 MiTek Industries, Inc. Mon May 15 15:24:11 2023 Page 1

ID:2GNsYO62BI49KgBFP3SlmayOXVO-RfC?PsB70Hq3NSgPqnL8w3uITXbGKwrcDoi7J4zJC?f

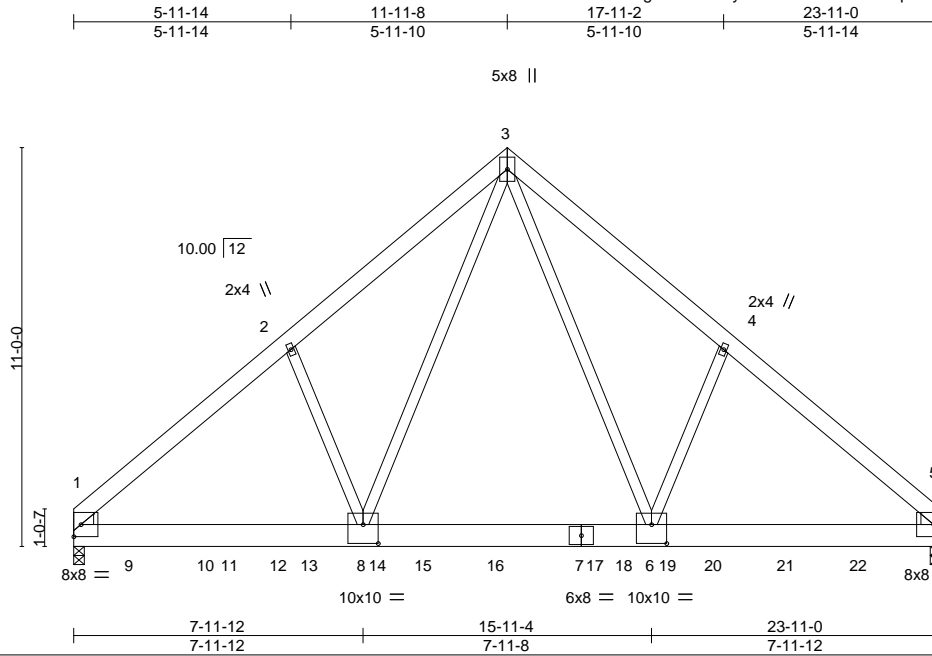

Plate Offsets (X,Y)--	[6:0-5-0,0-6-4], [8:0-5-0,0-6-4]
-----------------------	----------------------------------

LOADING (psf)	SPACING-	CSI.	DEFL.	PLATES	GRIP
TCLL 20.0	2-0-0	TC 0.79	in (loc) l/defl L/d	MT20	244/190
TCDL 10.0	Plate Grip DOL 1.15	BC 0.56	Vert(LL) -0.12 1-8 >999 360		
BCLL 0.0 *	Lumber DOL 1.15	WB 0.63	Vert(CT) -0.21 1-8 >999 240		
BCDL 10.0	Rep Stress Incr NO	Matrix-S	Horz(CT) 0.03 5 n/a n/a		
	Code IRC2018/TPI2014		Wind(LL) 0.07 1-8 >999 240	Weight: 393 lb	FT = 20%

LUMBER-	BRACING-
TOP CHORD 2x6 SP No.1	TOP CHORD Structural wood sheathing directly applied or 5-7-3 oc purlins.
BOT CHORD 2x8 SP 2400F 2.0E	BOT CHORD Rigid ceiling directly applied or 10-0-0 oc bracing.
WEBS 2x4 SP No.2	
WEDGE	
Left: 2x4 SP No.2, Right: 2x4 SP No.2	

REACTIONS. (size) 1=0-3-8, 5=0-3-8
 Max Horz 1=249(LC 28)
 Max Uplift 1=610(LC 8), 5=670(LC 9)
 Max Grav 1=7133(LC 2), 5=7803(LC 2)

FORCES. (lb) - Max. Comp./Max. Ten. - All forces 250 (lb) or less except when shown.
 TOP CHORD 1-2=-7992/722, 2-3=-7760/824, 3-4=-7705/820, 4-5=-7940/719
 BOT CHORD 1-8=-549/5833, 6-8=-309/4064, 5-6=-460/5790
 WEBS 3-6=-554/5016, 4-6=-307/388, 3-8=-561/5131, 2-8=-306/385

- NOTES-**
- 1) 2-ply truss to be connected together with 10d (0.131"x3") nails as follows:
 Top chords connected as follows: 2x6 - 2 rows staggered at 0-9-0 oc.
 Bottom chords connected as follows: 2x8 - 2 rows staggered at 0-9-0 oc.
 Webs connected as follows: 2x4 - 1 row at 0-9-0 oc.
 - 2) All loads are considered equally applied to all plies, except if noted as front (F) or back (B) face in the LOAD CASE(S) section. Ply to ply connections have been provided to distribute only loads noted as (F) or (B), unless otherwise indicated.
 - 3) Unbalanced roof live loads have been considered for this design.
 - 4) Wind: ASCE 7-16; Vult=130mph (3-second gust) Vasd=103mph; TC DL=6.0psf; BCDL=6.0psf; h=15ft; Cat. II; Exp C; Enclosed; MWFRS (envelope); Lumber DOL=1.60 plate grip DOL=1.60
 - 5) This truss has been designed for a 10.0 psf bottom chord live load nonconcurrent with any other live loads.
 - 6) * This truss has been designed for a live load of 30.0psf on the bottom chord in all areas where a rectangle 3-6-0 tall by 2-0-0 wide will fit between the bottom chord and any other members, with BCDL = 10.0psf.
 - 7) Provide mechanical connection (by others) of truss to bearing plate capable of withstanding 100 lb uplift at joint(s) except (jt=lb) 1=610, 5=670.
 - 8) This truss is designed in accordance with the 2018 International Residential Code sections R502.11.1 and R802.10.2 and referenced standard ANSI/TPI 1.
 - 9) Hanger(s) or other connection device(s) shall be provided sufficient to support concentrated load(s) 1068 lb down and 109 lb up at 1-6-12, 1062 lb down and 109 lb up at 3-6-12, 1040 lb down and 109 lb up at 5-6-12, 1068 lb down and 109 lb up at 7-6-12, 1052 lb down and 109 lb up at 9-6-12, 1038 lb down and 109 lb up at 11-6-12, 1041 lb down and 109 lb up at 13-6-12, 1068 lb down and 109 lb up at 15-6-12, 1068 lb down and 109 lb up at 17-6-12, 1068 lb down and 109 lb up at 19-6-12, and 1068 lb down and 109 lb up at 21-6-12, and 1081 lb down and 101 lb up at 23-9-4 on bottom chord. The design/selection of such connection device(s) is the responsibility of others.

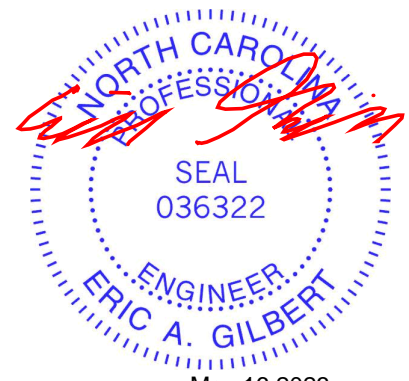

May 16, 2023

LOAD CASE(S) Standard

WARNING - Verify design parameters and READ NOTES ON THIS AND INCLUDED MITEK REFERENCE PAGE MII-7473 rev. 5/19/2020 BEFORE USE.
 Design valid for use only with MiTek® connectors. This design is based only upon parameters shown, and is for an individual building component, not a truss system. Before use, the building designer must verify the applicability of design parameters and properly incorporate this design into the overall building design. Bracing indicated is to prevent buckling of individual truss web and/or chord members only. Additional temporary and permanent bracing is always required for stability and to prevent collapse with possible personal injury and property damage. For general guidance regarding the fabrication, storage, delivery, erection and bracing of trusses and truss systems, see **ANSI/TPI1 Quality Criteria, DSB-89 and BCSI Building Component Safety Information** available from Truss Plate Institute, 2670 Crain Highway, Suite 203 Waldorf, MD 20601

ENGINEERING BY
TRENCO
 A MiTek Affiliate
 818 Soundside Road
 Edenton, NC 27932

Job J0723-3614	Truss D3	Truss Type COMMON GIRDER	Qty 1	Ply 2	Lot 4 Jones Creek / Harnett I58361103 Job Reference (optional)
-------------------	-------------	-----------------------------	----------	-----------------	--

Comtech, Inc. Fayetteville, NC - 28314,

8.430 s Jan 6 2022 MiTek Industries, Inc. Mon May 15 15:24:11 2023 Page 2
ID:2GNsYO62BI49KgBFP3SlmayOXVO-RfC?PsB70Hq3NSgPqnL8w3uITXbGKWrCDoi7J4zJC?f

LOAD CASE(S) Standard

1) Dead + Roof Live (balanced): Lumber Increase=1.15, Plate Increase=1.15

Uniform Loads (plf)

Vert: 1-3=-60, 3-5=-60, 1-5=-20

Concentrated Loads (lb)

Vert: 5=-963(F) 9=-955(F) 10=-955(F) 12=-955(F) 14=-955(F) 15=-955(F) 16=-955(F) 17=-955(F) 19=-955(F) 20=-955(F) 21=-955(F) 22=-955(F)

WARNING - Verify design parameters and READ NOTES ON THIS AND INCLUDED MITEK REFERENCE PAGE MII-7473 rev. 5/19/2020 BEFORE USE.

Design valid for use only with MiTek® connectors. This design is based only upon parameters shown, and is for an individual building component, not a truss system. Before use, the building designer must verify the applicability of design parameters and properly incorporate this design into the overall building design. Bracing indicated is to prevent buckling of individual truss web and/or chord members only. Additional temporary and permanent bracing is always required for stability and to prevent collapse with possible personal injury and property damage. For general guidance regarding the fabrication, storage, delivery, erection and bracing of trusses and truss systems, see **ANSI/TPI1 Quality Criteria, DSB-89 and BCSI Building Component Safety Information** available from Truss Plate Institute, 2670 Crain Highway, Suite 203 Waldorf, MD 20601



818 Soundside Road
Edenton, NC 27932

Job J0723-3614	Truss E1-GE	Truss Type GABLE	Qty 1	Ply 1	Lot 4 Jones Creek / Harnett Job Reference (optional)	158361104
-------------------	----------------	---------------------	----------	----------	---	-----------

Comtech, Inc. Fayetteville, NC - 28314,

8.430 s Jan 6 2022 MiTek Industries, Inc. Mon May 15 15:24:12 2023 Page 1

ID:2GNsYO62BI49KgBFP3SlmayOXVO-RfC?PsB70Hq3NSgPqnL8w3uITXbGKWrCDoi7J4zJC?f



Scale = 1:35.2

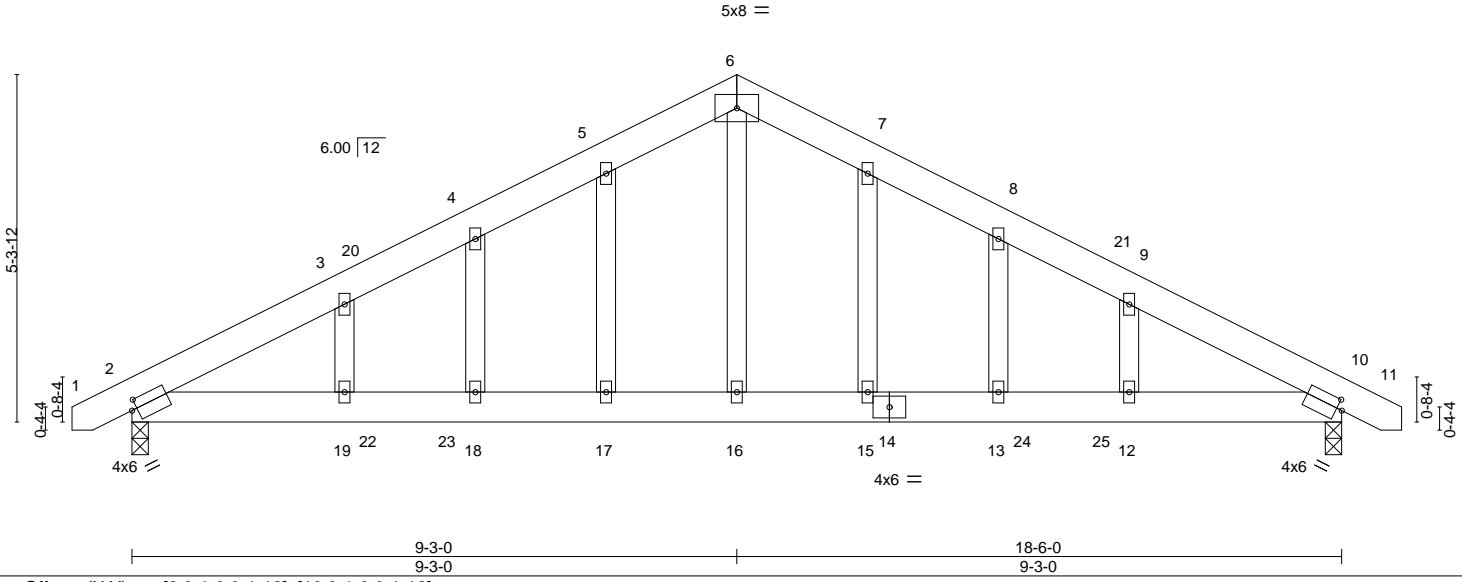

Plate Offsets (X, Y)--	[2:0-1-0,0-1-12], [10:0-1-0,0-1-12]				
LOADING (psf)	SPACING- 2-0-0	CSI.	DEFL. in (loc) l/defl L/d	PLATES	GRIP
TCLL 20.0	Plate Grip DOL 1.15	TC 0.32	Vert(LL) -0.07 12-13 >999 360	MT20	244/190
TCDL 10.0	Lumber DOL 1.15	BC 0.38	Vert(CT) -0.11 12-13 >999 240		
BCLL 0.0 *	Rep Stress Incr YES	WB 0.31	Horz(CT) -0.02 10 n/a n/a		
BCDL 10.0	Code IRC2018/TPI2014	Matrix-S	Wind(LL) 0.13 18-19 >999 240	Weight: 125 lb	FT = 20%

LUMBER-	BRACING-
TOP CHORD 2x6 SP No.1	TOP CHORD Structural wood sheathing directly applied or 6-0-0 oc purlins.
BOT CHORD 2x6 SP No.1	BOT CHORD Rigid ceiling directly applied or 6-7-7 oc bracing.
WEBS 2x4 SP No.2	
OTHERS 2x4 SP No.2	

REACTIONS. (size) 10=0-3-0, 2=0-3-0
 Max Horz 2=101(LC 16)
 Max Uplift 10=-211(LC 8), 2=-211(LC 9)
 Max Grav 10=783(LC 1), 2=783(LC 1)

FORCES. (lb) - Max. Comp./Max. Ten. - All forces 250 (lb) or less except when shown.
 TOP CHORD 2-3=-1028/1367, 3-4=-941/1353, 4-5=-908/1361, 5-6=-886/1403, 6-7=-886/1402,
 7-8=-908/1361, 8-9=-941/1353, 9-10=-1028/1366
 BOT CHORD 2-19=-1072/821, 18-19=-1072/821, 17-18=-1072/821, 16-17=-1072/821, 15-16=-1072/821,
 13-15=-1072/821, 12-13=-1072/821, 10-12=-1072/821
 WEBS 6-16=-832/458

- NOTES-**
- 1) Unbalanced roof live loads have been considered for this design.
 - 2) Wind: ASCE 7-16; Vult=130mph (3-second gust) Vasd=103mph; TCDL=6.0psf; BCDL=6.0psf; h=15ft; Cat. II; Exp C; Enclosed; Gable Roof; Common Truss; MWFRS (envelope) gable end zone and C-C Corner(3E) -0-9-2 to 3-7-11, Exterior(2N) 3-7-11 to 9-3-0, Corner(3R) 9-3-0 to 13-7-13, Exterior(2N) 13-7-13 to 19-3-2 zone; porch left and right exposed; C-C for members and forces & MWFRS for reactions shown; Lumber DOL=1.60 plate grip DOL=1.60
 - 3) Truss designed for wind loads in the plane of the truss only. For studs exposed to wind (normal to the face), see Standard Industry Gable End Details as applicable, or consult qualified building designer as per ANSI/TPI 1.
 - 4) All plates are 2x4 MT20 unless otherwise indicated.
 - 5) Gable studs spaced at 2-0-0 oc.
 - 6) This truss has been designed for a 10.0 psf bottom chord live load nonconcurrent with any other live loads.
 - 7) * This truss has been designed for a live load of 30.0psf on the bottom chord in all areas where a rectangle 3-6-0 tall by 2-0-0 wide will fit between the bottom chord and any other members.
 - 8) Provide mechanical connection (by others) of truss to bearing plate capable of withstanding 100 lb uplift at joint(s) except (jt=lb) 10=211, 2=211.
 - 9) This truss is designed in accordance with the 2018 International Residential Code sections R502.11.1 and R802.10.2 and referenced standard ANSI/TPI 1.
 - 10) See Standard Industry Piggyback Truss Connection Detail for Connection to base truss as applicable, or consult qualified building designer.



May 16, 2023

WARNING - Verify design parameters and READ NOTES ON THIS AND INCLUDED MITEK REFERENCE PAGE MII-7473 rev. 5/19/2020 BEFORE USE.
 Design valid for use only with MiTek® connectors. This design is based only upon parameters shown, and is for an individual building component, not a truss system. Before use, the building designer must verify the applicability of design parameters and properly incorporate this design into the overall building design. Bracing indicated is to prevent buckling of individual truss web and/or chord members only. Additional temporary and permanent bracing is always required for stability and to prevent collapse with possible personal injury and property damage. For general guidance regarding the fabrication, storage, delivery, erection and bracing of trusses and truss systems, see **ANSI/TPI1 Quality Criteria, DSB-89 and BCSI Building Component Safety Information** available from Truss Plate Institute, 2670 Crain Highway, Suite 203 Waldorf, MD 20601

ENGINEERING BY
TRENCO
 A MiTek Affiliate
 818 Soundside Road
 Edenton, NC 27932

Job J0723-3614	Truss E2	Truss Type COMMON	Qty 1	Ply 1	Lot 4 Jones Creek / Harnett I58361105
-------------------	-------------	----------------------	----------	----------	--

Comtech, Inc. Fayetteville, NC - 28314,

8.430 s Jan 6 2022 MiTek Industries, Inc. Mon May 15 15:24:13 2023 Page 1

ID:2GNsYO62BI49KgBFP3SlmayOXVO-RfC?PsB70Hq3NSgPqnL8w3uITXbGKwRCDoi7J4zJC?f

Job Reference (optional)



Scale = 1:35.2

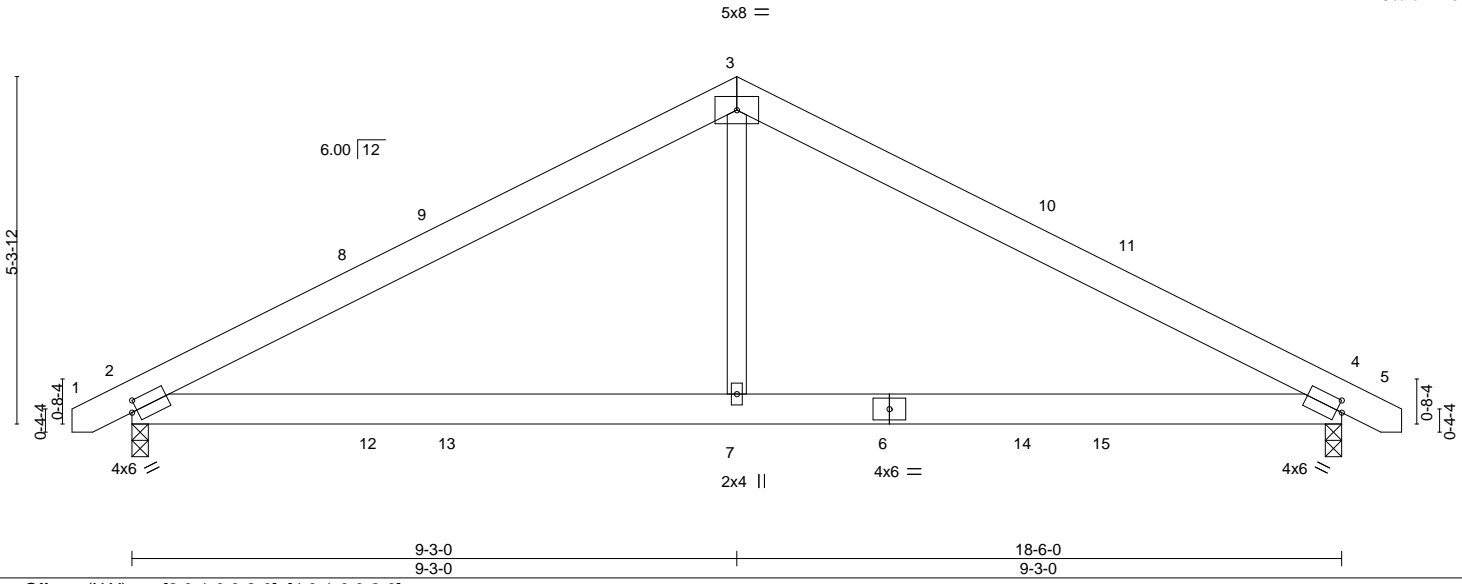

Plate Offsets (X, Y)--	[2:0-1-0,0-2-0], [4:0-1-0,0-2-0]
------------------------	----------------------------------

LOADING (psf)	SPACING-	CSI.	DEFL.	PLATES	GRIP
TCLL 20.0	2-0-0	TC 0.41	in (loc) l/defl L/d	MT20	244/190
TCDL 10.0	Plate Grip DOL 1.15	BC 0.33	Vert(LL) 0.14 2-7 >999 240		
BCLL 0.0 *	Lumber DOL 1.15	WB 0.27	Vert(CT) -0.09 4-7 >999 240		
BCDL 10.0	Rep Stress Incr YES	Matrix-S	Horz(CT) -0.01 4 n/a n/a		
	Code IRC2018/TPI2014			Weight: 104 lb	FT = 20%

LUMBER-	BRACING-
TOP CHORD 2x6 SP No.1	TOP CHORD Structural wood sheathing directly applied or 6-0-0 oc purlins.
BOT CHORD 2x6 SP No.1	BOT CHORD Rigid ceiling directly applied or 7-4-14 oc bracing.
WEBS 2x4 SP No.2	

REACTIONS. (size) 4=0-3-0, 2=0-3-0
 Max Horz 2=65(LC 11)
 Max Uplift 4=-165(LC 8), 2=-165(LC 9)
 Max Grav 4=783(LC 1), 2=783(LC 1)

FORCES. (lb) - Max. Comp./Max. Ten. - All forces 250 (lb) or less except when shown.
 TOP CHORD 2-3=-1027/1237, 3-4=-1027/1237
 BOT CHORD 2-7=-948/801, 4-7=-948/801
 WEBS 3-7=-734/444

- NOTES-**
- 1) Unbalanced roof live loads have been considered for this design.
 - 2) Wind: ASCE 7-16; Vult=130mph (3-second gust) Vasd=103mph; TC DL=6.0psf; BCDL=6.0psf; h=15ft; Cat. II; Exp C; Enclosed; MWFRS (envelope) and C-C Exterior(2E) -0-9-2 to 3-7-11, Interior(1) 3-7-11 to 9-3-0, Exterior(2R) 9-3-0 to 13-7-13, Interior(1) 13-7-13 to 19-3-2 zone; porch left and right exposed; C-C for members and forces & MWFRS for reactions shown; Lumber DOL=1.60 plate grip DOL=1.60
 - 3) This truss has been designed for a 10.0 psf bottom chord live load nonconcurrent with any other live loads.
 - 4) * This truss has been designed for a live load of 30.0psf on the bottom chord in all areas where a rectangle 3-6-0 tall by 2-0-0 wide will fit between the bottom chord and any other members.
 - 5) Provide mechanical connection (by others) of truss to bearing plate capable of withstanding 100 lb uplift at joint(s) except (jt=lb) 4=165, 2=165.
 - 6) This truss is designed in accordance with the 2018 International Residential Code sections R502.11.1 and R802.10.2 and referenced standard ANSI/TPI 1.
 - 7) See Standard Industry Piggyback Truss Connection Detail for Connection to base truss as applicable, or consult qualified building designer.

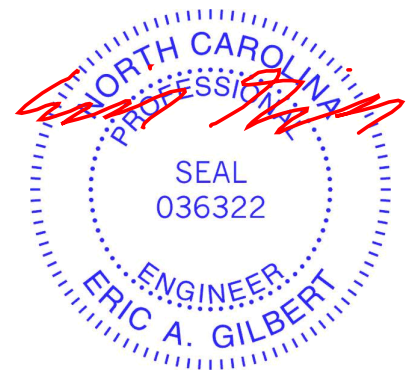

Job J0723-3614	Truss E3	Truss Type COMMON	Qty 1	Ply 1	Lot 4 Jones Creek / Harnett I58361106
Comtech, Inc. Fayetteville, NC - 28314,					Job Reference (optional)

8.430 s Jan 6 2022 MiTek Industries, Inc. Mon May 15 15:24:14 2023 Page 1
ID:2GNsYO62BI49KgBFP3SlmayOXVO-RfC?PsB70Hq3NSgPqnL8w3ulTXbGKWrCDoi7J4zJC?f

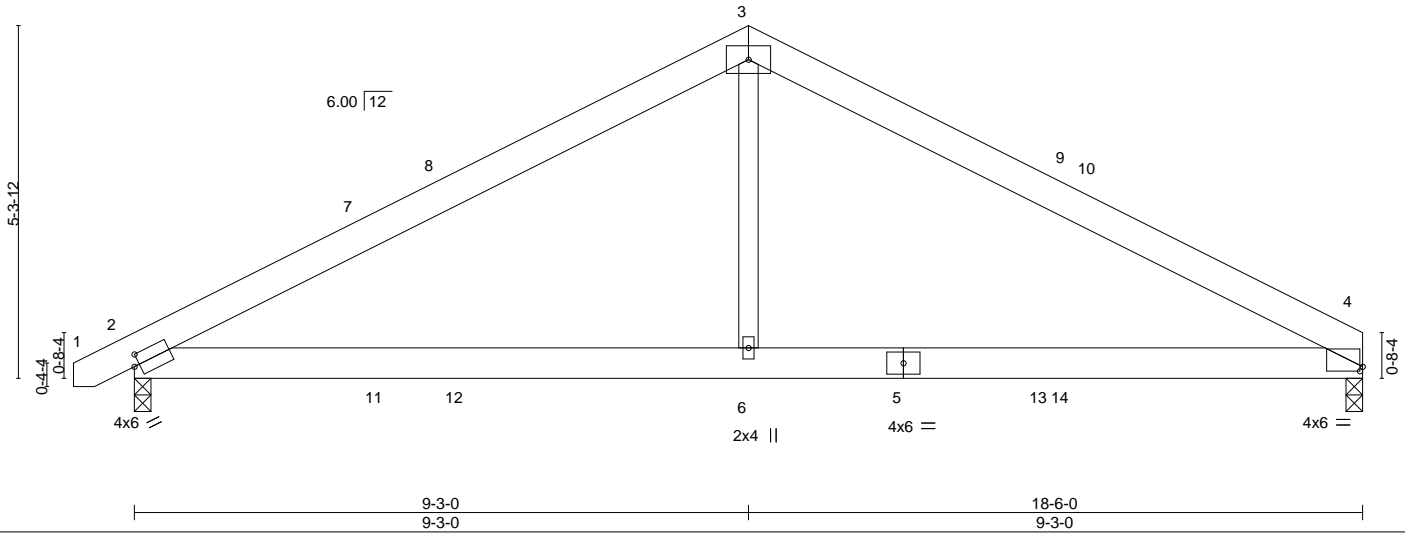
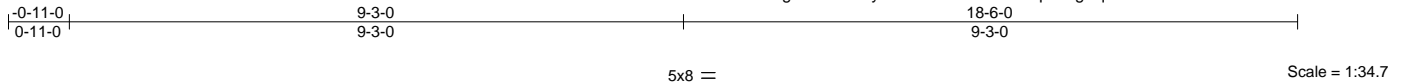

Plate Offsets (X, Y)--	[2:0-1-0,0-2-0], [4:0-0-8,0-0-13]
------------------------	-----------------------------------

LOADING (psf)	SPACING-	2-0-0	CSI.	DEFL.	in (loc)	l/defl	L/d	PLATES	GRIP
TCLL 20.0	Plate Grip DOL	1.15	TC 0.44	Vert(LL)	0.14	4-6	>999	MT20	244/190
TCDL 10.0	Lumber DOL	1.15	BC 0.33	Vert(CT)	-0.09	4-6	>999		
BCLL 0.0 *	Rep Stress Incr	YES	WB 0.27	Horz(CT)	-0.01	4	n/a		
BCDL 10.0	Code IRC2018/TPI2014		Matrix-S						
								Weight: 101 lb	FT = 20%

LUMBER-	BRACING-
TOP CHORD 2x6 SP No.1	TOP CHORD Structural wood sheathing directly applied or 6-0-0 oc purlins.
BOT CHORD 2x6 SP No.1	BOT CHORD Rigid ceiling directly applied or 7-3-15 oc bracing.
WEBS 2x4 SP No.2	

REACTIONS.	(size)
	4=0-3-0, 2=0-3-0
	Max Horz 2=66(LC 9)
	Max Uplift 4=-160(LC 8), 2=-165(LC 9)
	Max Grav 4=729(LC 1), 2=784(LC 1)

FORCES.	(lb) - Max. Comp./Max. Ten. - All forces 250 (lb) or less except when shown.
TOP CHORD	2-3=-1030/1238, 3-4=-1027/1246
BOT CHORD	2-6=-970/803, 4-6=-970/803
WEBS	3-6=-739/446

- NOTES-**
- Unbalanced roof live loads have been considered for this design.
 - Wind: ASCE 7-16; Vult=130mph (3-second gust) Vasd=103mph; TCCL=6.0psf; BCDL=6.0psf; h=15ft; Cat. II; Exp C; Enclosed; MWFRS (envelope) and C-C Exterior(2E) -0-9-2 to 3-7-11, Interior(1) 3-7-11 to 9-3-0, Exterior(2R) 9-3-0 to 13-7-13, Interior(1) 13-7-13 to 18-4-8 zone; porch left and right exposed; C-C for members and forces & MWFRS for reactions shown; Lumber DOL=1.60 plate grip DOL=1.60
 - This truss has been designed for a 10.0 psf bottom chord live load nonconcurrent with any other live loads.
 - * This truss has been designed for a live load of 30.0psf on the bottom chord in all areas where a rectangle 3-6-0 tall by 2-0-0 wide will fit between the bottom chord and any other members.
 - Provide mechanical connection (by others) of truss to bearing plate capable of withstanding 100 lb uplift at joint(s) except (jt=lb) 4=160, 2=165.
 - This truss is designed in accordance with the 2018 International Residential Code sections R502.11.1 and R802.10.2 and referenced standard ANSI/TPI 1.
 - See Standard Industry Piggyback Truss Connection Detail for Connection to base truss as applicable, or consult qualified building designer.



Job J0723-3614	Truss E4	Truss Type COMMON	Qty 3	Ply 1	Lot 4 Jones Creek / Harnett Job Reference (optional)	158361107
-------------------	-------------	----------------------	----------	----------	---	-----------

Comtech, Inc. Fayetteville, NC - 28314,

8.430 s Jan 6 2022 MiTek Industries, Inc. Mon May 15 15:24:15 2023 Page 1

ID:2GNsYO62BI49KgBFP3SlmayOXVO-RfC?PsB70Hq3NSgPqnL8w3ulTXbGKWrCDoi7J4zJC?f



5x8 =

Scale = 1:33.9

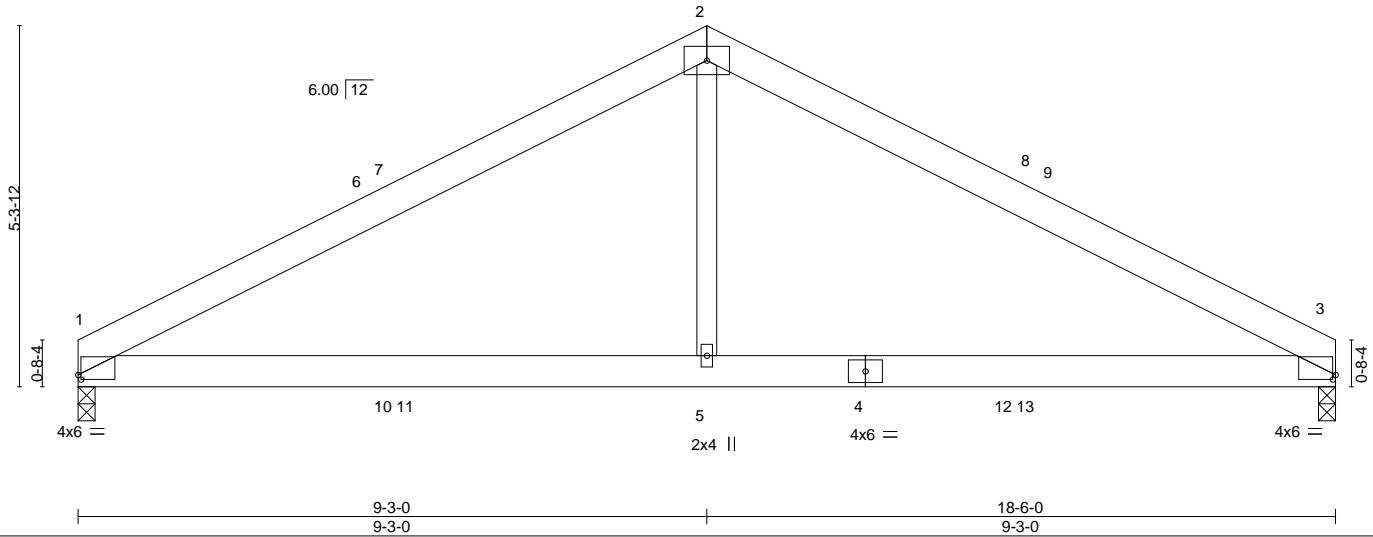

Plate Offsets (X,Y)-- [1:0-0-8,0-0-13], [3:0-0-8,0-0-13]					
LOADING (psf)	SPACING- 2-0-0	CSI.	DEFL. in (loc) l/defl L/d	PLATES	GRIP
TCLL 20.0	Plate Grip DOL 1.15	TC 0.44	Vert(LL) 0.14 1-5 >999 240	MT20	244/190
TCDL 10.0	Lumber DOL 1.15	BC 0.33	Vert(CT) -0.09 3-5 >999 240		
BCLL 0.0 *	Rep Stress Incr YES	WB 0.27	Horz(CT) -0.01 3 n/a n/a		
BCDL 10.0	Code IRC2018/TPI2014	Matrix-S		Weight: 99 lb	FT = 20%

LUMBER-	BRACING-
TOP CHORD 2x6 SP No.1	TOP CHORD Structural wood sheathing directly applied or 6-0-0 oc purlins.
BOT CHORD 2x6 SP No.1	BOT CHORD Rigid ceiling directly applied or 7-3-15 oc bracing.
WEBS 2x4 SP No.2	

REACTIONS. (size) 1=0-3-0, 3=0-3-0
 Max Horz 1=-63(LC 8)
 Max Uplift 1=-161(LC 9), 3=-161(LC 8)
 Max Grav 1=730(LC 1), 3=730(LC 1)

FORCES. (lb) - Max. Comp./Max. Ten. - All forces 250 (lb) or less except when shown.
 TOP CHORD 1-2=-1029/1247, 2-3=-1029/1247
 BOT CHORD 1-5=-972/806, 3-5=-972/806
 WEBS 2-5=-738/447

- NOTES-**
- Unbalanced roof live loads have been considered for this design.
 - Wind: ASCE 7-16; Vult=130mph (3-second gust) Vasd=103mph; TC DL=6.0psf; BCDL=6.0psf; h=15ft; Cat. II; Exp C; Enclosed; MWFRS (envelope) and C-C Exterior(2E) 0-1-8 to 4-6-5, Interior(1) 4-6-5 to 9-3-0, Exterior(2R) 9-3-0 to 13-7-13, Interior(1) 13-7-13 to 18-4-8 zone; porch left and right exposed; C-C for members and forces & MWFRS for reactions shown; Lumber DOL=1.60 plate grip DOL=1.60
 - This truss has been designed for a 10.0 psf bottom chord live load nonconcurrent with any other live loads.
 - * This truss has been designed for a live load of 30.0psf on the bottom chord in all areas where a rectangle 3-6-0 tall by 2-0-0 wide will fit between the bottom chord and any other members.
 - Provide mechanical connection (by others) of truss to bearing plate capable of withstanding 100 lb uplift at joint(s) except (jt=lb) 1=161, 3=161.
 - This truss is designed in accordance with the 2018 International Residential Code sections R502.11.1 and R802.10.2 and referenced standard ANSI/TPI 1.



May 16, 2023

<p>WARNING - Verify design parameters and READ NOTES ON THIS AND INCLUDED MITEK REFERENCE PAGE MII-7473 rev. 5/19/2020 BEFORE USE.</p> <p>Design valid for use only with MiTek® connectors. This design is based only upon parameters shown, and is for an individual building component, not a truss system. Before use, the building designer must verify the applicability of design parameters and properly incorporate this design into the overall building design. Bracing indicated is to prevent buckling of individual truss web and/or chord members only. Additional temporary and permanent bracing is always required for stability and to prevent collapse with possible personal injury and property damage. For general guidance regarding the fabrication, storage, delivery, erection and bracing of trusses and truss systems, see ANSI/TPI1 Quality Criteria, DSB-89 and BCSI Building Component Safety Information available from Truss Plate Institute, 2670 Crain Highway, Suite 203 Waldorf, MD 20601</p>	<p>818 Soundside Road Edenton, NC 27932</p>
--	---

Job J0723-3614	Truss VD-1	Truss Type Valley	Qty 1	Ply 1	Lot 4 Jones Creek / Harnett 158361108
-------------------	---------------	----------------------	----------	----------	--

Comtech, Inc. Fayetteville, NC - 28314,

8.430 s Jan 6 2022 MiTek Industries, Inc. Mon May 15 15:24:16 2023 Page 1

ID:2GNsYO62BI49KgBFP3SlmayOXVO-RfC?PsB70Hq3NSgPqnL8w3ulTXbGKWrcDoi7J4zJC?f



4x4 =

Scale = 1:25.8

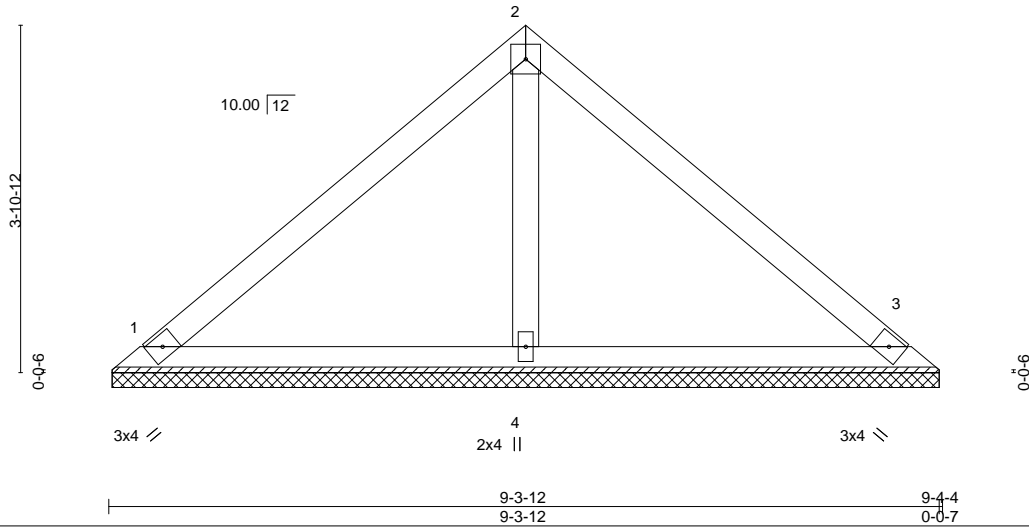

LOADING (psf)	SPACING-	CSI.	DEFL.	in (loc)	l/defl	L/d	PLATES	GRIP
TCLL 20.0	2-0-0	TC 0.20	Vert(LL)	n/a	-	n/a	MT20	244/190
TCDL 10.0	Plate Grip DOL 1.15	BC 0.14	Vert(CT)	n/a	-	n/a		
BCLL 0.0 *	Lumber DOL 1.15	WB 0.04	Horz(CT)	0.00	3	n/a		
BCDL 10.0	Rep Stress Incr YES	Matrix-S					Weight: 35 lb	FT = 20%
	Code IRC2018/TPI2014							

LUMBER-
 TOP CHORD 2x4 SP No.1
 BOT CHORD 2x4 SP No.1
 OTHERS 2x4 SP No.2

BRACING-
 TOP CHORD Structural wood sheathing directly applied or 6-0-0 oc purlins.
 BOT CHORD Rigid ceiling directly applied or 10-0-0 oc bracing.

REACTIONS. (size) 1=9-3-5, 3=9-3-5, 4=9-3-5
 Max Horz 1=85(LC 9)
 Max Uplift 1=-20(LC 13), 3=-28(LC 13)
 Max Grav 1=183(LC 1), 3=183(LC 1), 4=319(LC 1)

FORCES. (lb) - Max. Comp./Max. Ten. - All forces 250 (lb) or less except when shown.

NOTES-

- 1) Unbalanced roof live loads have been considered for this design.
- 2) Wind: ASCE 7-16; Vult=130mph (3-second gust) Vasd=103mph; TCDL=6.0psf; BCDL=6.0psf; h=15ft; Cat. II; Exp C; Enclosed; MWFRS (envelope) and C-C Exterior(2E) zone; C-C for members and forces & MWFRS for reactions shown; Lumber DOL=1.60 plate grip DOL=1.60
- 3) Gable requires continuous bottom chord bearing.
- 4) This truss has been designed for a 10.0 psf bottom chord live load nonconcurrent with any other live loads.
- 5) * This truss has been designed for a live load of 30.0psf on the bottom chord in all areas where a rectangle 3-6-0 tall by 2-0-0 wide will fit between the bottom chord and any other members.
- 6) Provide mechanical connection (by others) of truss to bearing plate capable of withstanding 100 lb uplift at joint(s) 1, 3.
- 7) This truss is designed in accordance with the 2018 International Residential Code sections R502.11.1 and R802.10.2 and referenced standard ANSI/TPI 1.

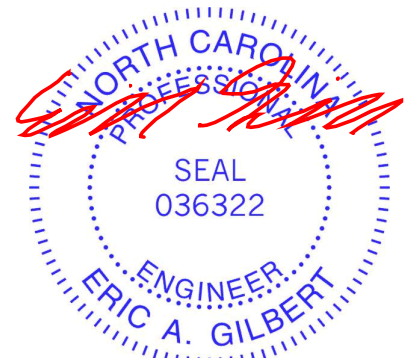

May 16, 2023

WARNING - Verify design parameters and READ NOTES ON THIS AND INCLUDED MITEK REFERENCE PAGE MII-7473 rev. 5/19/2020 BEFORE USE.

Design valid for use only with MiTek® connectors. This design is based only upon parameters shown, and is for an individual building component, not a truss system. Before use, the building designer must verify the applicability of design parameters and properly incorporate this design into the overall building design. Bracing indicated is to prevent buckling of individual truss web and/or chord members only. Additional temporary and permanent bracing is always required for stability and to prevent collapse with possible personal injury and property damage. For general guidance regarding the fabrication, storage, delivery, erection and bracing of trusses and truss systems, see

ANSI/TPI1 Quality Criteria, DSB-89 and BCSI Building Component

Safety Information available from Truss Plate Institute, 2670 Crain Highway, Suite 203 Waldorf, MD 20601



818 Soundside Road
 Edenton, NC 27932

Job J0723-3614	Truss VD-2	Truss Type Valley	Qty 1	Ply 1	Lot 4 Jones Creek / Harnett Job Reference (optional)	158361109
-------------------	---------------	----------------------	----------	----------	---	-----------

Comtech, Inc. Fayetteville, NC - 28314,

8.430 s Jan 6 2022 MiTek Industries, Inc. Mon May 15 15:24:17 2023 Page 1

ID:2GNsYO62BI49KgBFP3SlmayOXVO-RfC?PsB70Hq3NSgPqnL8w3uITXbGKWrCDoi7J4zJC?f



Scale = 1:19.9

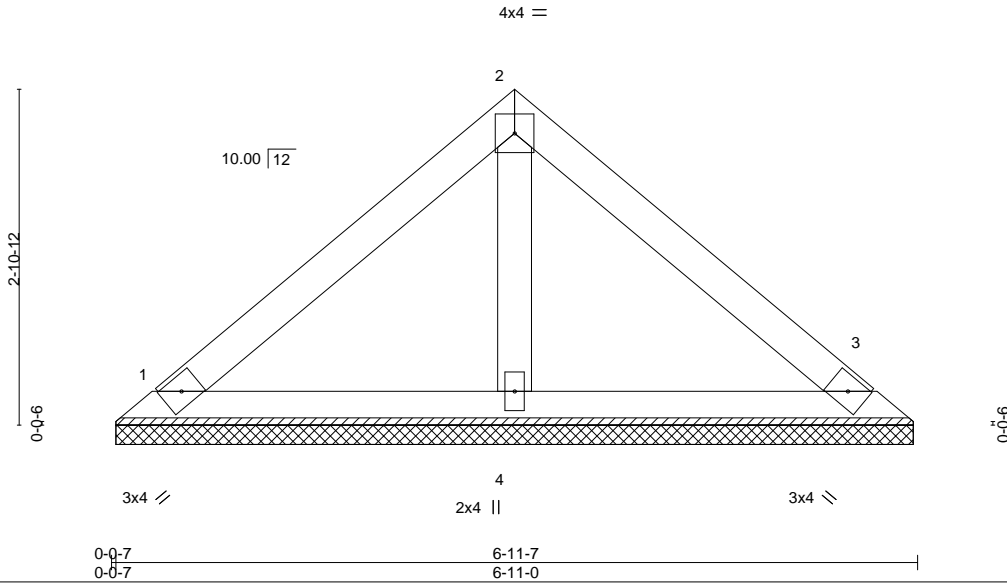

LOADING (psf)	SPACING-	CSI.	DEFL.	in (loc)	l/defl	L/d	PLATES	GRIP
TCLL 20.0	2-0-0	TC 0.18	Vert(LL)	n/a	-	n/a	MT20	244/190
TCDL 10.0	Plate Grip DOL 1.15	BC 0.07	Vert(CT)	n/a	-	n/a		
BCLL 0.0 *	Lumber DOL 1.15	WB 0.02	Horz(CT)	0.00	3	n/a		
BCDL 10.0	Rep Stress Incr YES	Matrix-P					Weight: 26 lb	FT = 20%
	Code IRC2018/TPI2014							

LUMBER-
 TOP CHORD 2x4 SP No.1
 BOT CHORD 2x4 SP No.1
 OTHERS 2x4 SP No.2

BRACING-
 TOP CHORD Structural wood sheathing directly applied or 6-0-0 oc purlins.
 BOT CHORD Rigid ceiling directly applied or 10-0-0 oc bracing.

REACTIONS. (size) 1=6-10-8, 3=6-10-8, 4=6-10-8
 Max Horz 1=61(LC 9)
 Max Uplift 1=-21(LC 13), 3=-27(LC 13)
 Max Grav 1=142(LC 1), 3=142(LC 1), 4=207(LC 1)

FORCES. (lb) - Max. Comp./Max. Ten. - All forces 250 (lb) or less except when shown.

NOTES-

- 1) Unbalanced roof live loads have been considered for this design.
- 2) Wind: ASCE 7-16; Vult=130mph (3-second gust) Vasd=103mph; TCDL=6.0psf; BCDL=6.0psf; h=15ft; Cat. II; Exp C; Enclosed; MWFRS (envelope) and C-C Exterior(2E) zone; C-C for members and forces & MWFRS for reactions shown; Lumber DOL=1.60 plate grip DOL=1.60
- 3) Gable requires continuous bottom chord bearing.
- 4) This truss has been designed for a 10.0 psf bottom chord live load nonconcurrent with any other live loads.
- 5) * This truss has been designed for a live load of 30.0psf on the bottom chord in all areas where a rectangle 3-6-0 tall by 2-0-0 wide will fit between the bottom chord and any other members.
- 6) Provide mechanical connection (by others) of truss to bearing plate capable of withstanding 100 lb uplift at joint(s) 1, 3.
- 7) This truss is designed in accordance with the 2018 International Residential Code sections R502.11.1 and R802.10.2 and referenced standard ANSI/TPI 1.



May 16, 2023

WARNING - Verify design parameters and READ NOTES ON THIS AND INCLUDED MITEK REFERENCE PAGE MII-7473 rev. 5/19/2020 BEFORE USE.

Design valid for use only with MiTek® connectors. This design is based only upon parameters shown, and is for an individual building component, not a truss system. Before use, the building designer must verify the applicability of design parameters and properly incorporate this design into the overall building design. Bracing indicated is to prevent buckling of individual truss web and/or chord members only. Additional temporary and permanent bracing is always required for stability and to prevent collapse with possible personal injury and property damage. For general guidance regarding the fabrication, storage, delivery, erection and bracing of trusses and truss systems, see **ANSI/TPI1 Quality Criteria, DSB-89 and BCSI Building Component Safety Information** available from Truss Plate Institute, 2670 Crain Highway, Suite 203 Waldorf, MD 20601



818 Soundside Road
 Edenton, NC 27932

Job J0723-3614	Truss VD-3	Truss Type Valley	Qty 1	Ply 1	Lot 4 Jones Creek / Harnett Job Reference (optional)	158361110
-------------------	---------------	----------------------	----------	----------	---	-----------

Comtech, Inc. Fayetteville, NC - 28314,

8.430 s Jan 6 2022 MiTek Industries, Inc. Mon May 15 15:24:18 2023 Page 1

ID:2GNsYO62BI49KgBFP3SlmayOXVO-RfC?PsB70Hq3NSgPqnL8w3uITXbGKWrCDoi7J4zJC?f

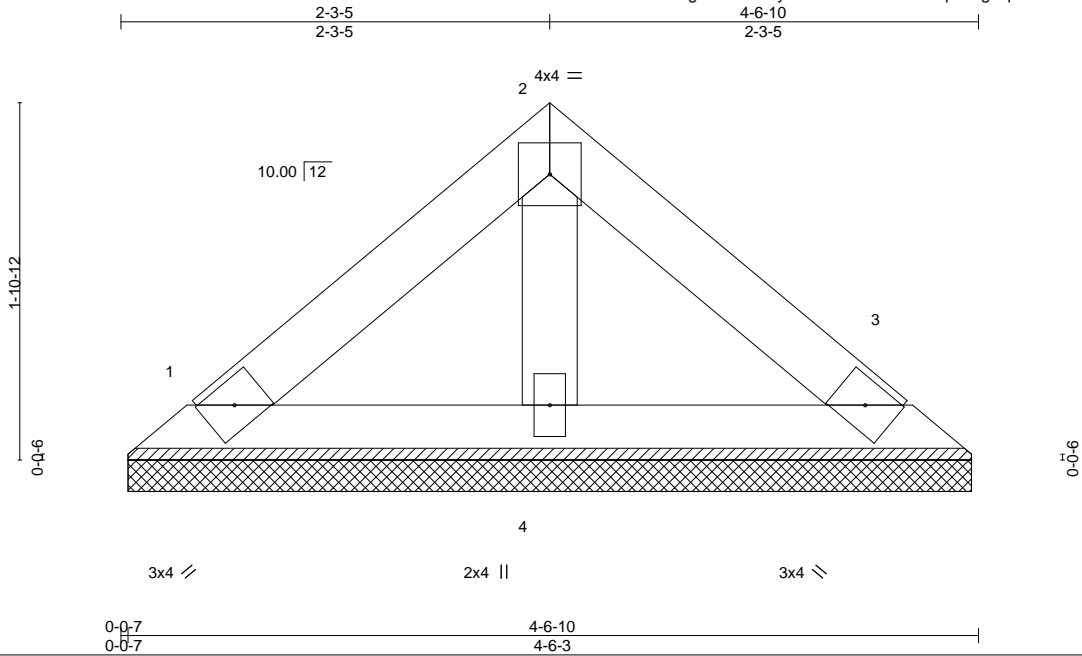

Scale = 1:12.2

LOADING (psf)	SPACING-	CSI.	DEFL.	in (loc)	l/defl	L/d	PLATES	GRIP
TCLL 20.0	2-0-0	TC 0.07	Vert(LL)	n/a	-	n/a	MT20	244/190
TCDL 10.0	Plate Grip DOL 1.15	BC 0.03	Vert(CT)	n/a	-	n/a		
BCLL 0.0 *	Lumber DOL 1.15	WB 0.01	Horz(CT)	0.00	3	n/a		
BCDL 10.0	Rep Stress Incr YES	Matrix-P					Weight: 16 lb	FT = 20%
	Code IRC2018/TPI2014							

LUMBER-
 TOP CHORD 2x4 SP No.1
 BOT CHORD 2x4 SP No.1
 OTHERS 2x4 SP No.2

BRACING-
 TOP CHORD Structural wood sheathing directly applied or 4-6-10 oc purlins.
 BOT CHORD Rigid ceiling directly applied or 10-0-0 oc bracing.

REACTIONS. (size) 1=4-5-12, 3=4-5-12, 4=4-5-12
 Max Horz 1=37(LC 8)
 Max Uplift 1=13(LC 13), 3=16(LC 13)
 Max Grav 1=87(LC 1), 3=87(LC 1), 4=126(LC 1)

FORCES. (lb) - Max. Comp./Max. Ten. - All forces 250 (lb) or less except when shown.

NOTES-

- 1) Unbalanced roof live loads have been considered for this design.
- 2) Wind: ASCE 7-16; Vult=130mph (3-second gust) Vasd=103mph; TCCL=6.0psf; BCDL=6.0psf; h=15ft; Cat. II; Exp C; Enclosed; MWFRS (envelope) and C-C Exterior(2E) zone; C-C for members and forces & MWFRS for reactions shown; Lumber DOL=1.60 plate grip DOL=1.60
- 3) Gable requires continuous bottom chord bearing.
- 4) This truss has been designed for a 10.0 psf bottom chord live load nonconcurrent with any other live loads.
- 5) * This truss has been designed for a live load of 30.0psf on the bottom chord in all areas where a rectangle 3-6-0 tall by 2-0-0 wide will fit between the bottom chord and any other members.
- 6) Provide mechanical connection (by others) of truss to bearing plate capable of withstanding 100 lb uplift at joint(s) 1, 3.
- 7) This truss is designed in accordance with the 2018 International Residential Code sections R502.11.1 and R802.10.2 and referenced standard ANSI/TPI 1.

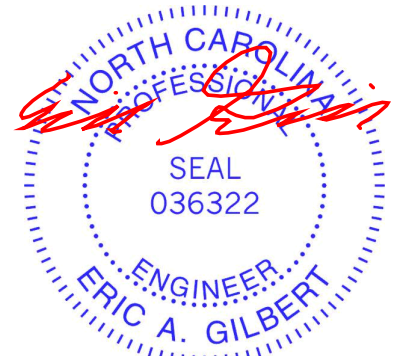

May 16, 2023

WARNING - Verify design parameters and READ NOTES ON THIS AND INCLUDED MITEK REFERENCE PAGE MII-7473 rev. 5/19/2020 BEFORE USE.

Design valid for use only with MiTek® connectors. This design is based only upon parameters shown, and is for an individual building component, not a truss system. Before use, the building designer must verify the applicability of design parameters and properly incorporate this design into the overall building design. Bracing indicated is to prevent buckling of individual truss web and/or chord members only. Additional temporary and permanent bracing is always required for stability and to prevent collapse with possible personal injury and property damage. For general guidance regarding the fabrication, storage, delivery, erection and bracing of trusses and truss systems, see

ANSI/TPI1 Quality Criteria, DSB-89 and BCSI Building Component

Safety Information available from Truss Plate Institute, 2670 Crain Highway, Suite 203 Waldorf, MD 20601



818 Soundside Road
 Edenton, NC 27932

Symbols

PLATE LOCATION AND ORIENTATION



Center plate on joint unless x, y offsets are indicated. Dimensions are in ft-in-sixteenths. Apply plates to both sides of truss and fully embed teeth.



For 4 x 2 orientation, locate plates 0- 1/16" from outside edge of truss.



This symbol indicates the required direction of slots in connector plates.

* Plate location details available in **MITek 20/20 software** or upon request.

PLATE SIZE

4 X 4

The first dimension is the plate width measured perpendicular to slots. Second dimension is the length parallel to slots.

LATERAL BRACING LOCATION



Indicated by symbol shown and/or by text in the bracing section of the output. Use T or I bracing if indicated.

BEARING



Indicates location where bearings (supports) occur. Icons vary but reaction section indicates joint number where bearings occur. Min size shown is for crushing only.

Industry Standards:

ANSI/TFP 1: National Design Specification for Metal Plate Connected Wood Truss Construction.
DSB-89: Design Standard for Bracing, Building Component Safety Information, Guide to Good Practice for Handling, Installing & Bracing of Metal Plate Connected Wood Trusses.

Numbering System

6-4-8
dimensions shown in ft-in-sixteenths
(Drawings not to scale)



JOINTS ARE GENERALLY NUMBERED/LETTERED CLOCKWISE AROUND THE TRUSS STARTING AT THE JOINT FARTHEST TO THE LEFT.

CHORDS AND WEBS ARE IDENTIFIED BY END JOINT NUMBERS/LETTERS.

PRODUCT CODE APPROVALS

ICC-ES Reports:

ESR-1311, ESR-1352, ESR1988
ER-3907, ESR-2362, ESR-1397, ESR-3282

Trusses are designed for wind loads in the plane of the truss unless otherwise shown.

Lumber design values are in accordance with ANSI/TFP 1 section 6.3 These truss designs rely on lumber values established by others.

© 2012 MITteK® All Rights Reserved



MITek Engineering Reference Sheet: MII-7473 rev. 5/19/2020



General Safety Notes

Failure to Follow Could Cause Property Damage or Personal Injury

1. Additional stability bracing for truss system, e.g. diagonal or X-bracing, is always required. See BCSI.
2. Truss bracing must be designed by an engineer. For wide truss spacing, individual lateral braces themselves may require bracing, or alternative Tor I bracing should be considered.
3. Never exceed the design loading shown and never stack materials on inadequately braced trusses.
4. Provide copies of this truss design to the building designer, erection supervisor, property owner and all other interested parties.
5. Cut members to bear tightly against each other.
6. Place plates on each face of truss at each joint and embed fully. Knots and wane at joint locations are regulated by ANSI/TFP 1.
7. Design assumes trusses will be suitably protected from the environment in accord with ANSI/TFP 1.
8. Unless otherwise noted, moisture content of lumber shall not exceed 19% at time of fabrication.
9. Unless expressly noted, this design is not applicable for use with fire retardant, preservative treated, or green lumber.
10. Camber is a non-structural consideration and is the responsibility of truss fabricator. General practice is to camber for dead load deflection.
11. Plate type, size, orientation and location dimensions indicated are minimum plating requirements.
12. Lumber used shall be of the species and size, and in all respects, equal to or better than that specified.
13. Top chords must be sheathed or purlins provided at spacing indicated on design.
14. Bottom chords require lateral bracing at 10 ft. spacing, or less, if no ceiling is installed, unless otherwise noted.
15. Connections not shown are the responsibility of others.
16. Do not cut or alter truss member or plate without prior approval of an engineer.
17. Install and load vertically unless indicated otherwise.
18. Use of green or treated lumber may pose unacceptable environmental, health or performance risks. Consult with project engineer before use.
19. Review all portions of this design (front, back, words and pictures) before use. Reviewing pictures alone is not sufficient.
20. Design assumes manufacture in accordance with ANSI/TFP 1 Quality Criteria.
21. The design does not take into account any dynamic or other loads other than those expressly stated.