

FRONT ELEVATION

Scale: 1/4" = 1'0"

9'0" CEILING HEIGHT FIRST FLOOR
(HEADER HEIGHT 7'6")
8'0" CEILING HEIGHT SECOND FLOOR
(2X10" HEADERS FRAMED TO TOP PLATES')

FRAME WINDOWS TO HEADER HEIGHT



LEFT ELEVATION

Scale: 1/8" = 1'0"



REAR ELEVATION

Scale: 1/8" = 1'0"



RIGHT ELEVATION

Scale: 1/8" = 1'0"

PLAN:
Rand

SHEET TITLE:
ELEVATIONS

PROJECT ADDRESS:
16 Hancock Ct.
Liberty Meadows Lot 35

DESIGNED BY:
Precision Custom Homes
Raeford, NC
Shaun@PrecisionCustomHomesNC.com

DATE:

8/15/23

SCALE:

1/4" = 1'

SHEET:

A-1

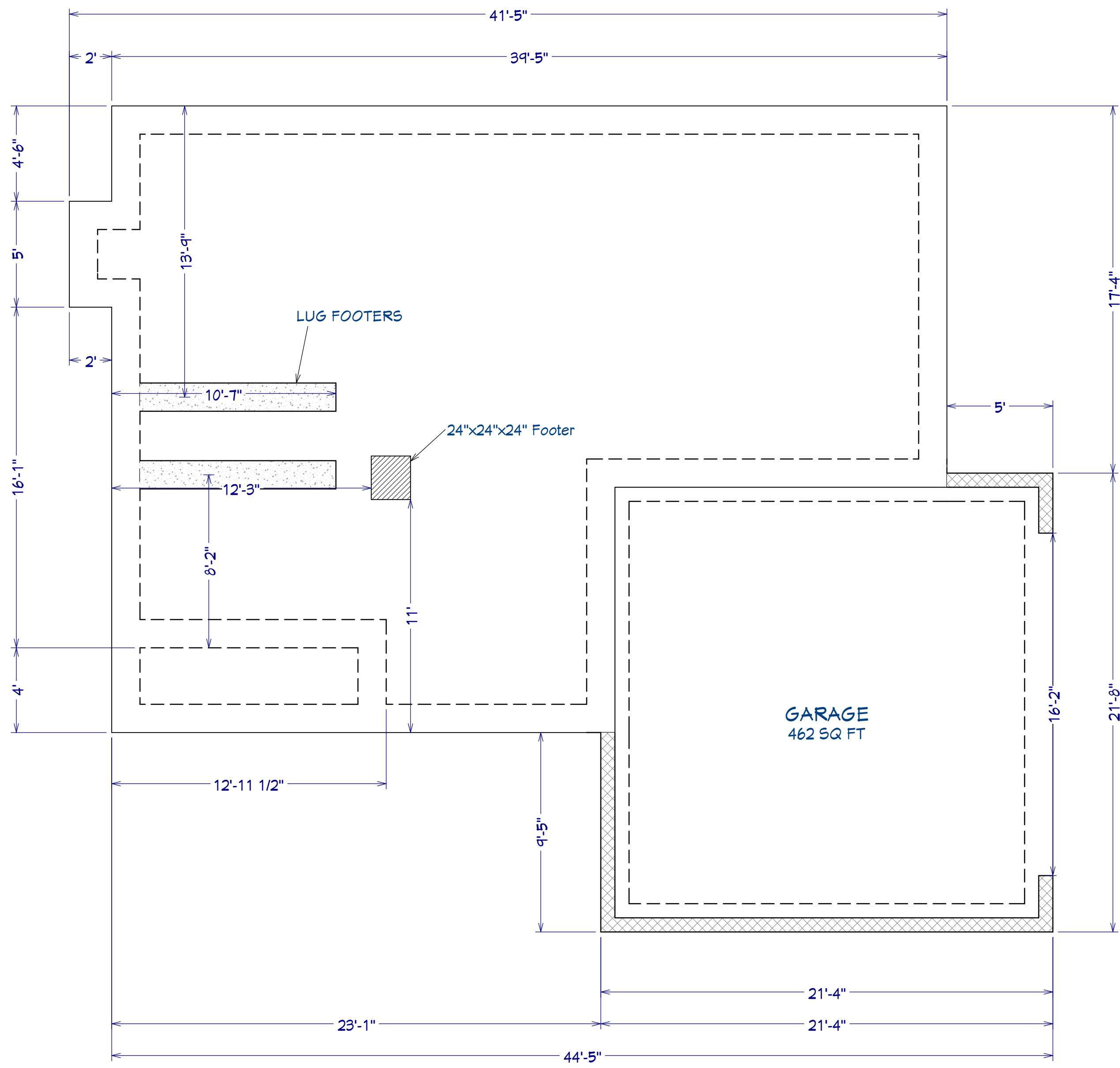

AREA SCHEDULE	
NAME	AREA
1st FLOOR	1,001 SF
2nd FLOOR	1,074 SF
GARAGE	422 SF
FRONT PORCH	51 SF
TOTAL HEATED	2,075 SF
TOTAL UNDER ROOF	2,548 SF

FOUNDATION PLAN
Scale: 1/4" = 1'0"

SHEET TITLE:
FOUNDATION

PROJECT ADDRESS:
16 Hancock Ct.
Liberty Meadows Lot 35

DESIGNED BY:
Precision Custom Homes
RaeFord, NC
Shaun@PrecisionCustomHomesNC.com

DATE:
8/15/23

SCALE:
1/4" = 1'

SHEET:
A-2

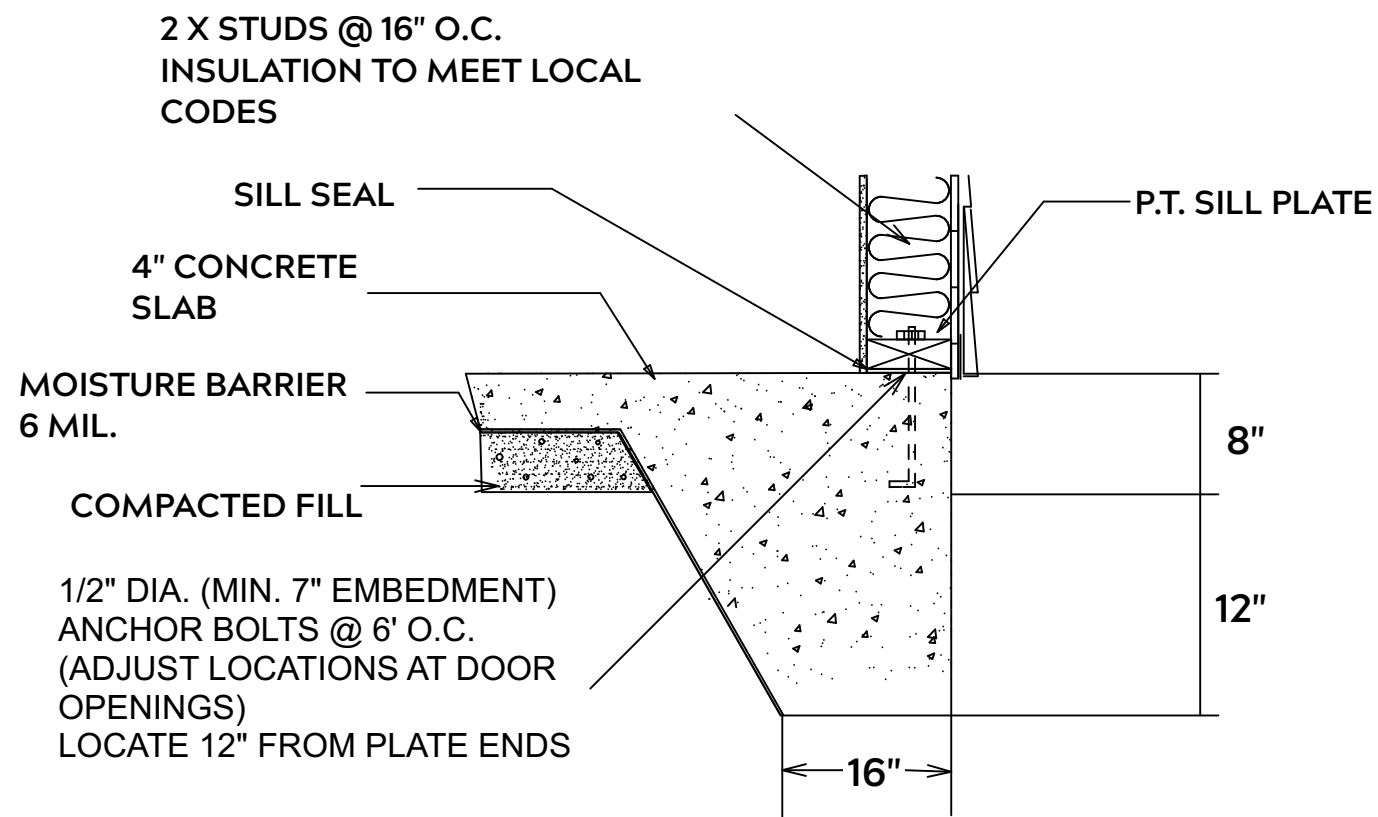

MONOLITHIC SLAB

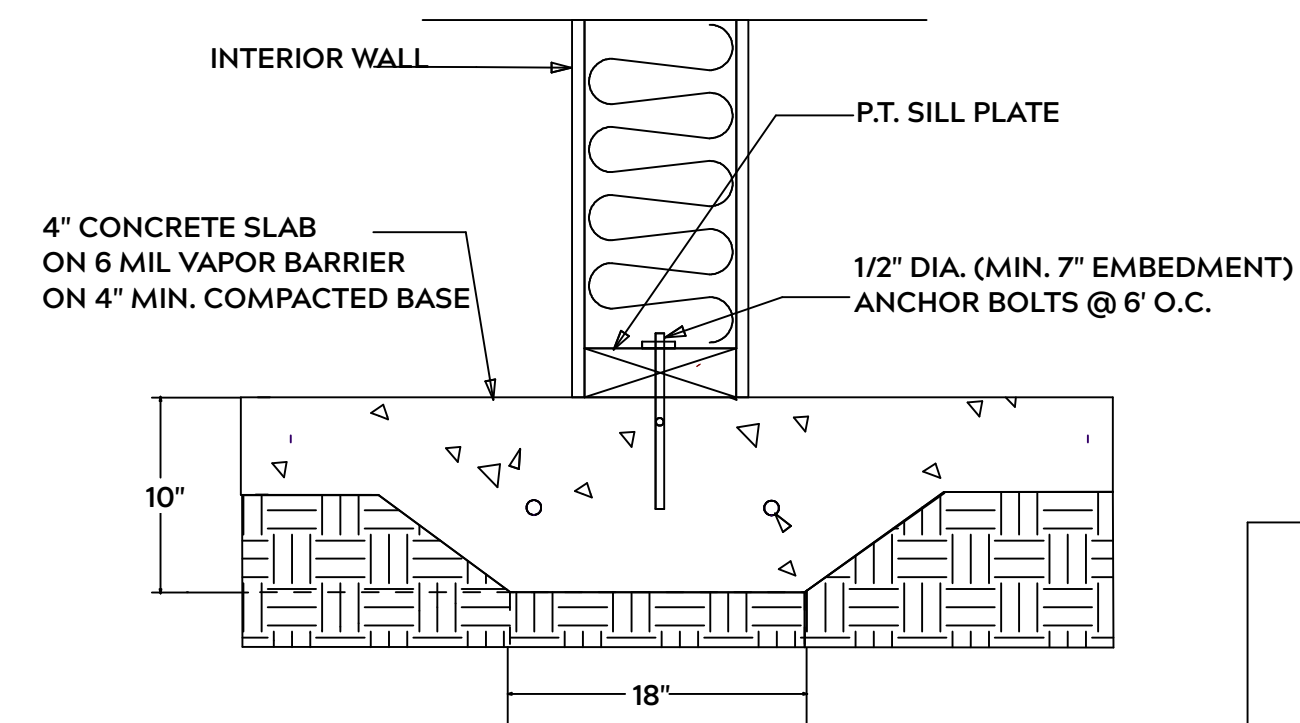

LUG FOOTING

FOUNDATION NOTES:

ALL FOOTINGS SHALL BEAR ON ORIGINAL UNDISTURBED SOIL
THE 28 DAY COMPRESSIVE STRENGTH OF ALL FOOTINGS IS 3000 PSI

PROVIDE WATER PROOFING AND PERIMTER DRAINS AS REQUIRED

FOOTING WIDTHS ARE BASED ON A LOAD BEARING SOIL CAPACITY OF 2000 PSI

PROVIDE 6 MIL POLY VAPOR BARRIER TO COVER GROUND IN CRAWL SPACE AND GROUND UNDER POURED CONCRETE

ALL ANCHOR BOLTS TO BE 1/2" X 12" LONG. ANCHOR BOLTS SHALL BE SPACED AT A MAXIMUM OF 6' ON CENTER AND NO MORE THEN 1' FROM EACH CORNER

GENERAL FRAMING NOTES:

ALL LUMBER IN CONTACT WITH CONCRETE OR MASONRY SHALLE BE PRESSURE TREATED

FRAMING LUMBER SHALL BE SYP #2 GRADE AND / OR SPRUCE PINE FIR #1 AND / OR KILN DRIED

WHERE PRE-ENGINEERED JOISTS AND TRUSSES ARE USED, MANUFACTURER SHALL PROVIDE DRAWINGS / SCHEMATICS, WHICH SHALL BEAR OF A N.C. ENGINEER

STUDS AND JOISTS SHALL NOT BE CUT TO INSTALL PLUMBING OR WIRING WITHOUT ADDING METAL OR WOOD SIDE PANELS TO STRENGTHEN MEMBER TO ITS ORIGINAL CAPACITY

NAIL MULTIPLE MEMBERS WITH 2 ROWS OF 16d NAILS STAGGERED 32" O.C. AND USE 3 X 16d NAILS 2" IN AT EACH END.

NAIL FLOOR JOISTS TO SILL PLATE WITH WITH 8d TOE NAILS

ALL EXPOSED FRAMING ON PORCHES OR DECKS SHALL BE PRESSURE TREATED

PROVIDE WATERPROOFING AND DRAINS AS REQUIRED

ALL FRAMING TO BE 16" O.C. WALL FRAMING DIMENSIONS ARE BASED ON 2X4 OR 2X6 EXTERIOR WALLS AND 2X4 INTERIOR WALLS. DOULBE / TRIPLE JACK STUDS AS NECESSARY UNDER HEADERS AS REQUIRED

LVL'S TO BE SIZED BY OTHERS (TRUSS MANUFACTURER)

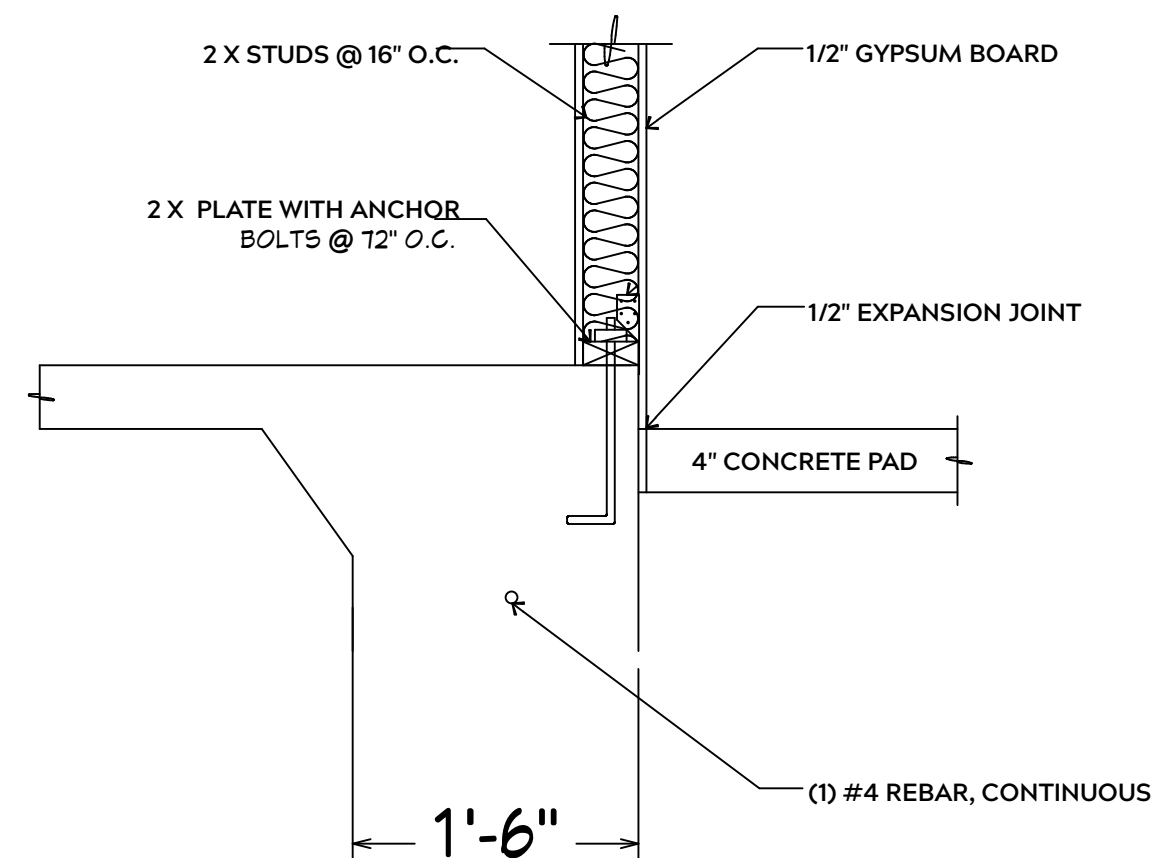

INTERIOR WALL @ GARAGE STEP DOWN

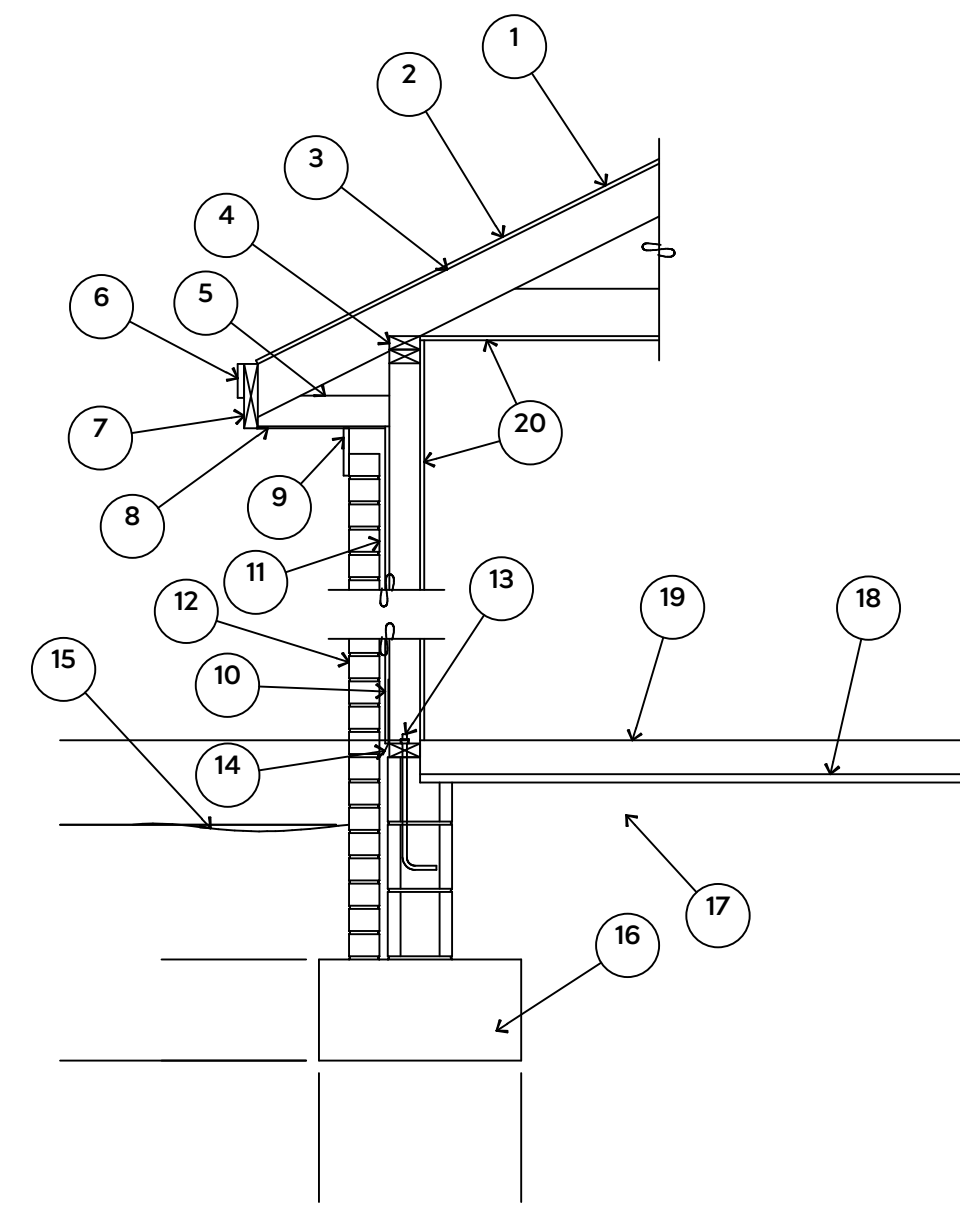

1. 15# FELT UNDERLAYMENT UNDER COMPOSITION SHINGLES.
2. ROOF DECKING.
3. 2 X RAFTERS / ENGINEERED TRUSSES
4. DOUBLE TOP PLATE.
5. 2 X 4 RETURN.
6. 3/4" FASCIA OR PVC TRIM COIL
7. 2 X FASCIA
8. 1/4" PLYWOOD OR VINYL SOFFIT
9. 1 X FREIZE BOARD (TO BE USED WITH BRICK VENEERS)
10. INSULATION BOARD OR HOUSE WRAP
11. AIR SPACE.
12. BRICK WITH BRICK TIES PER MANUFACTURER'S SPECIFICATIONS.
13. 1/2" X 12" ANCHOR BOLTS, 6'-0" O.C., 12" FROM CORNERS.
14. FLASHING WITH WEEP HOLES @ 48" O.C.
15. FINISHED GRADE.
16. FOOTING
17. COMPACTED EARTH FILL.
18. 6 MIL. VAPOR BARRIER
19. 4" CONCRETE SLAB, 3,000 P.S.I. WITH 6" X 6" 10 GA. X 10 GA. WELDED WIRE FABRIC.
20. 1/2" GYPSUM BOARD.

EXTERIOR WALL SECTION

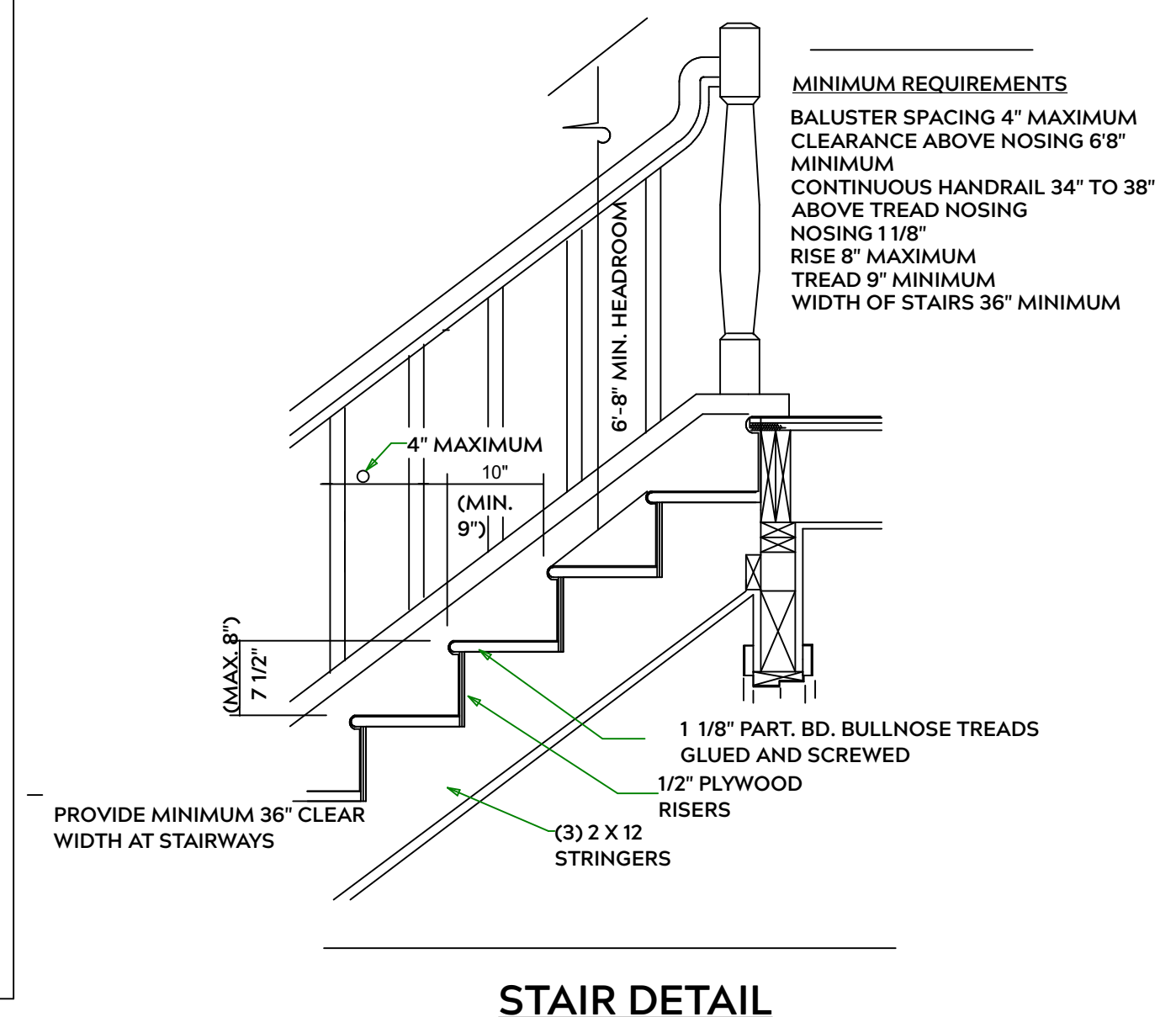

STAIR DETAIL

PLAN:
Rand

SHEET TITLE:
DETAIL SHEETS

PROJECT ADDRESS:
**16 Hancock Ct.
Liberty Meadows Lot 35**

DESIGNED BY:
Precision Custom Homes
Rae ford, NC
Shaun@PrecisionCustomHomesNC.com

DATE:

8/15/23

SCALE:

1/4" = 1'

SHEET:

A-3

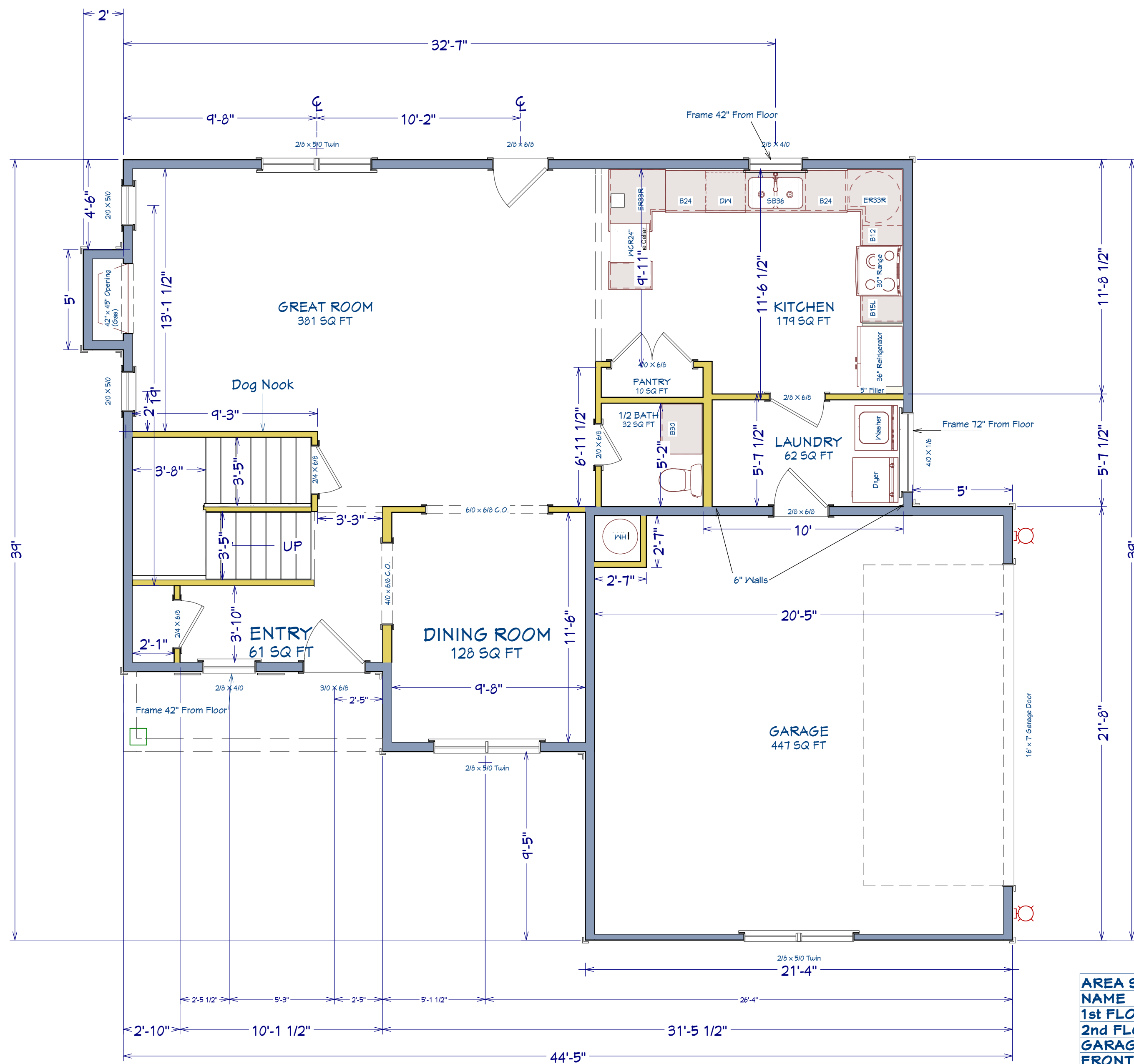

AREA SCHEDULE	
NAME	AREA
1st FLOOR	1,001 SF
2nd FLOOR	1,074 SF
GARAGE	422 SF
FRONT PORCH	51 SF
TOTAL HEATED	2,075 SF
TOTAL UNDER ROOF	2,548 SF

SHEET TITLE:

1st FLOOR

PROJECT ADDRESS:
16 Hancock Ct.
Liberty Meadows Lot 35

DESIGNED BY:
Precision Custom Homes
Raeferd, NC
Shaun@PrecisionCustomHomesNC.com

DATE:
8/15/23

SCALE:
1/4" = 1'

SHEET:
A-4

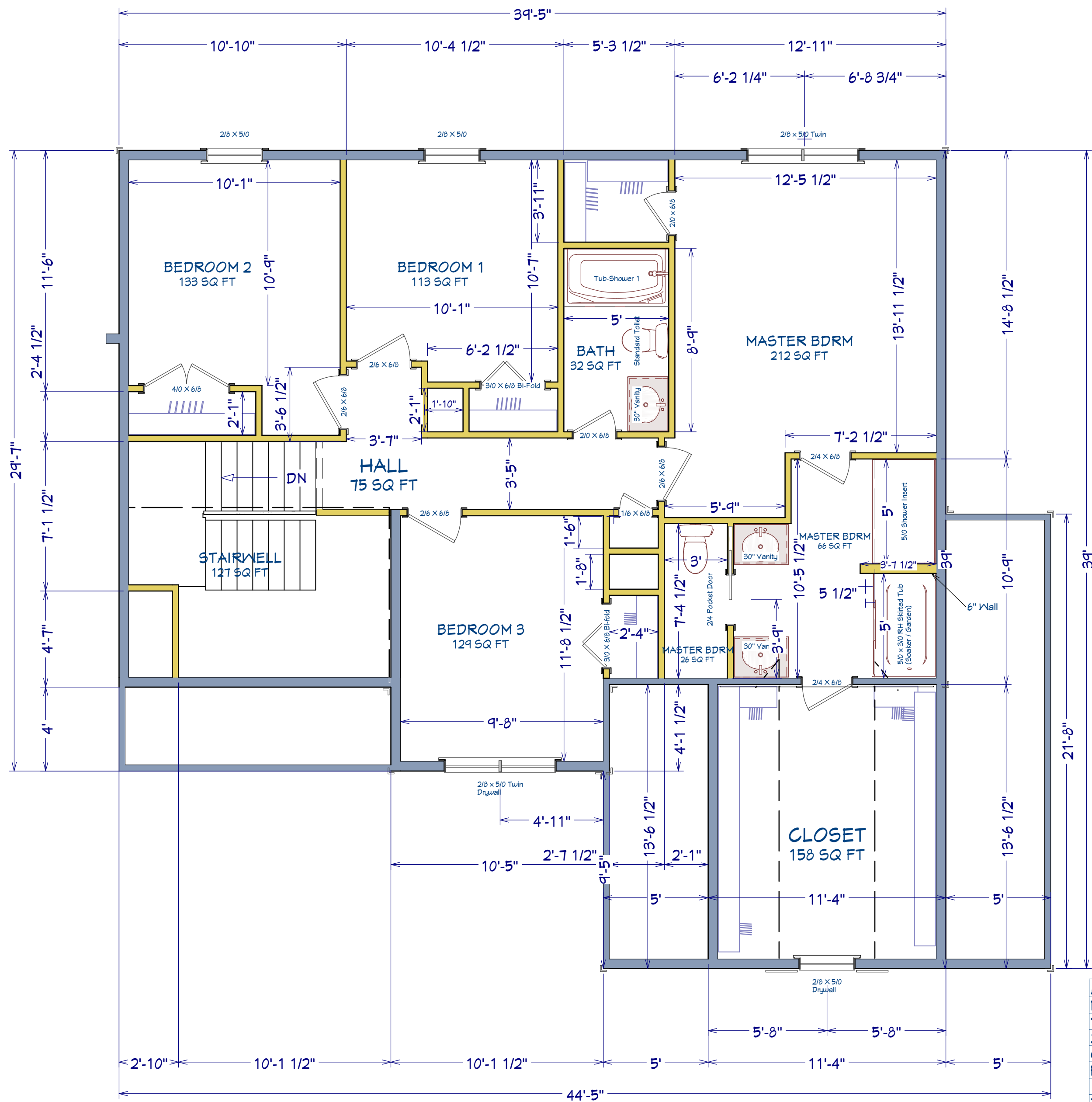

AREA SCHEDULE NAME	AREA
1st FLOOR	1,001 SF
2nd FLOOR	1,074 SF
GARAGE	422 SF
FRONT PORCH	51 SF
TOTAL HEATED	2,075 SF
TOTAL UNDER ROOF	2,548 SF

PLAN:
Rand

SHEET TITLE:
2nd FLOOR

PROJECT ADDRESS:
16 Hancock Ct.
Liberty Meadows Lot 35

DESIGNED BY:
Precision Custom Homes
RaeFord, NC
Shaun@PrecisionCustomHomesNC.com

DATE:
8/15/23

SCALE:
1/4" = 1'

SHEET:
A-5



ROOF & FLOOR TRUSSES & BEAMS

Reilly Road Industrial Park
Fayetteville, N.C. 28309
Phone: (910) 864-8787
Fax: (910) 864-4444

Bearing reactions less than or equal to 3000# are deemed to comply with the prescriptive Code requirements. The contractor shall refer to the attached Tables (derived from the prescriptive Code requirements) to determine the minimum foundation size and number of wood studs required to support reactions greater than 3000# but not greater than 15000#. A registered design professional shall be retained to design the support system for any reaction that exceeds those specified in the attached Tables. A registered design professional shall be retained to design the support system for all reactions that exceed 15000#.

Signature _____
Neil Baggett

LOAD CHART FOR JACK STUDS

(BASED ON TABLES R502.5(1) & (b))

NUMBER OF JACK STUDS REQUIRED @ EA END OF HEADER/GIRDER		NUMBER OF JACK STUDS REQUIRED @ EA END OF HEADER/GIRDER		NUMBER OF JACK STUDS REQUIRED @ EA END OF HEADER/GIRDER	
END REACTION (UP TO)	REQ. D. STUDS FOR (1) 1/2" HEADER	END REACTION (UP TO)	REQ. D. STUDS FOR (1) 1/2" HEADER	END REACTION (UP TO)	REQ. D. STUDS FOR (1) 1/2" HEADER
1700	1	2550	1	3400	1
3400	2	5100	2	6800	2
5100	3	7650	3	10200	3
6800	4	10200	4	13600	4
8500	5	12750	5	17000	5
10200	6	15300	6		
11900	7				
13600	8				
15300	9				

Dimension Notes

- All exterior wall to wall dimensions are to face of stud unless noted otherwise
- All interior wall dimensions are to face of stud unless noted otherwise
- All exterior wall to truss dimensions are to face of stud unless noted otherwise

Plumbing Drop Notes

- Plumbing drop locations shown are NOT exact.
- Contractor to verify ALL plumbing drop locations prior to setting Floor Trusses.
- Adjust spacing as needed not to exceed 24" oc.

Hatch Legend

	Vaulted Ceiling
	Padded HVAC
	2nd Floor Walls @ 8' 1 1/2" UNO
	Drop Beam
	Flush Beam

Roof Area = 2204.59 sq.ft.
Ridge Line = 78.26 ft.
Hip Line = 0 ft.
Horiz. OH = 130.55 ft.
Raked OH = 214.53 ft.
Decking = 76 sheets

All Walls Shown Are Considered Load Bearing

▲ = Indicates Left End of Truss
(Reference Engineered Truss Drawing)
Do Not Erect Trusses Backwards

1 Truss Placement Plan
Scale: 1/4"=1'

Connector Information				Nail Information		
Sym	Product	Manuf	Qty	Supported Member	Header	Truss
	HUS410	USP	13	Varies	16d/3-1/2"	16d/3-1/2"
	MSH422	USP	8	Varies	10d/3"	10d/3"
	HUS26	USP	5	Varies	16d/3-1/2"	16d/3-1/2"
	THDH412	USP	1	NA	16d /3-1/2"	16d /3-1/2"

Products					
PlotID	Length	Product	Plies	Net Qty	Fab Type
GDH-SL	22' 0"	1.75 X 24 Kerto-S LVL 2.0E	2	2	FF
BM1	8' 0"	1-3/4"x 14" LVL Kerto-S	2	2	FF
BM2	22' 0"	1-3/4"x 23-7/8" LVL Kerto-S	2	2	FF

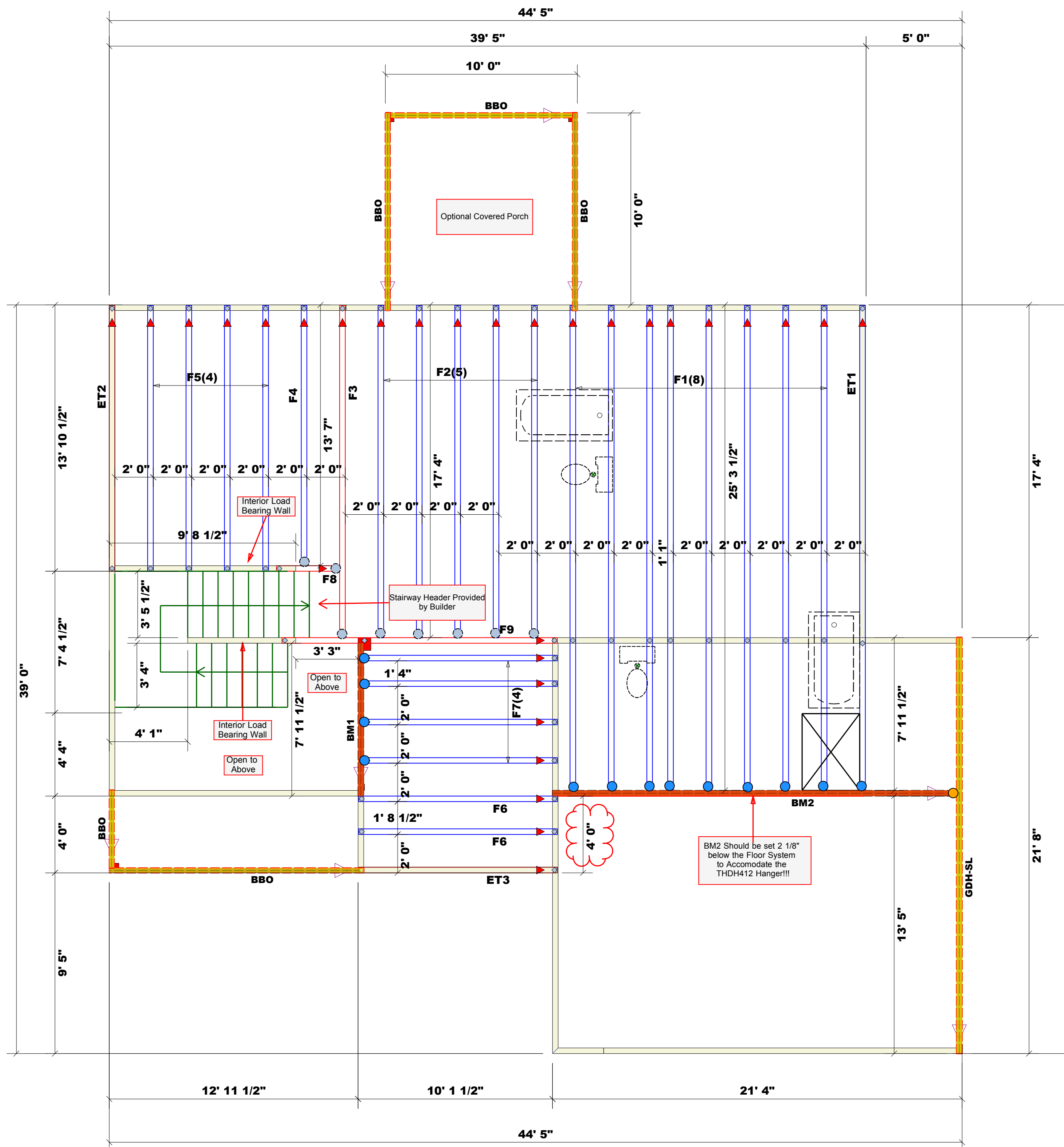

BUILDER	JOB NAME	PLAN	SEAL DATE	QUOTE #	JOB #
Precision Custom Homes	Lot 35 Liberty Meadows	Rand 1.0 w/GDH-SL	N/A	N/A	J0823-4325

COUNTY	ADDRESS	MODEL	DATE REV.	DRAWN BY	SALESMAN
Harnett	Lot 35 Liberty Meadows	Floor	8/12/2023	Neil Baggett	Neil Baggett

THIS IS A TRUSS PLACEMENT DIAGRAM ONLY.
These trusses are designed as individual building components to be incorporated into the building design at the specification of the building designer. See individual design sheets for each truss design identified on the placement drawing. The building designer is responsible for temporary and permanent bracing of the roof and floor system and for the overall structure. The design of the truss support structure including headers, beams, walls, and columns is the responsibility of the building designer. For general guidance regarding bracing, consult BCSI-B1 and BCSI-B3 provided with the truss delivery package or online @ sbciindustry.com



ROOF & FLOOR TRUSSES & BEAMS

Reilly Road Industrial Park
Fayetteville, N.C. 28309
Phone: (910) 864-8787
Fax: (910) 864-4444

Bearing reactions less than or equal to 3000# are deemed to comply with the prescriptive Code requirements. The contractor shall refer to the attached Tables (derived from the prescriptive Code requirements) to determine the minimum foundation size and number of wood studs required to support reactions greater than 3000# but not greater than 15000#. A registered design professional shall be retained to design the support system for any reaction that exceeds those specified in the attached Tables. A registered design professional shall be retained to design the support system for all reactions that exceed 15000#.

Signature
Neil Baggett

LOAD CHART FOR JACK STUDS

(BASED ON TABLES R502.5(1) & (b))

NUMBER OF JACK STUDS REQUIRED @ EA END OF HEADER/GIRDER		NUMBER OF JACK STUDS REQUIRED @ EA END OF HEADER/GIRDER		NUMBER OF JACK STUDS REQUIRED @ EA END OF HEADER/GIRDER	
END REACTION (UP TO)	REQ. D. STUDS FOR (1) 1/2" HEADER	END REACTION (UP TO)	REQ. D. STUDS FOR (1) 1/2" HEADER	END REACTION (UP TO)	REQ. D. STUDS FOR (1) 1/2" HEADER
1700	1	2550	1	3400	1
3400	2	5100	2	6800	2
5100	3	7650	3	10200	3
6800	4	10200	4	13600	4
8500	5	12750	5	17000	5
10200	6	15300	6		
11900	7				
13600	8				
15300	9				

Dimension Notes

- All exterior wall to wall dimensions are to face of stud unless noted otherwise
- All interior wall dimensions are to face of stud unless noted otherwise
- All exterior wall to truss dimensions are to face of stud unless noted otherwise

Plumbing Drop Notes

- Plumbing drop locations shown are NOT exact.
- Contractor to verify ALL plumbing drop locations prior to setting Floor Trusses.
- Adjust spacing as needed not to exceed 24"oc.

Hatch Legend

	Vaulted Ceiling
	Padded HVAC
	2nd Floor Walls @ 8' 1 1/2" UNO
	Drop Beam
	Flush Beam

Roof Area = 2204.59 sq.ft.
Ridge Line = 78.26 ft.
Hip Line = 0 ft.
Horiz. OH = 130.55 ft.
Raked OH = 214.53 ft.
Decking = 76 sheets

All Walls Shown Are Considered Load Bearing

▲ = Indicates Left End of Truss
(Reference Engineered Truss Drawing)
Do Not Erect Trusses Backwards

1 Truss Placement Plan
Scale: 1/4"=1'

Connector Information				Nail Information		
Sym	Product	Manuf	Qty	Supported Member	Header	Truss
●	HUS410	USP	13	Varies	16d/3-1/2"	16d/3-1/2"
●	MSH422	USP	8	Varies	10d/3"	10d/3"
●	HUS26	USP	5	Varies	16d/3-1/2"	16d/3-1/2"

Products					
PlotID	Length	Product	Piles	Net Qty	Fab Type
GDH	22' 0"	1-3/4"x 11-7/8" LVL Kerto-S	2	2	FF
BM1	8' 0"	1-3/4"x 14" LVL Kerto-S	2	2	FF
BM2	22' 0"	1-3/4"x 23-7/8" LVL Kerto-S	2	2	FF

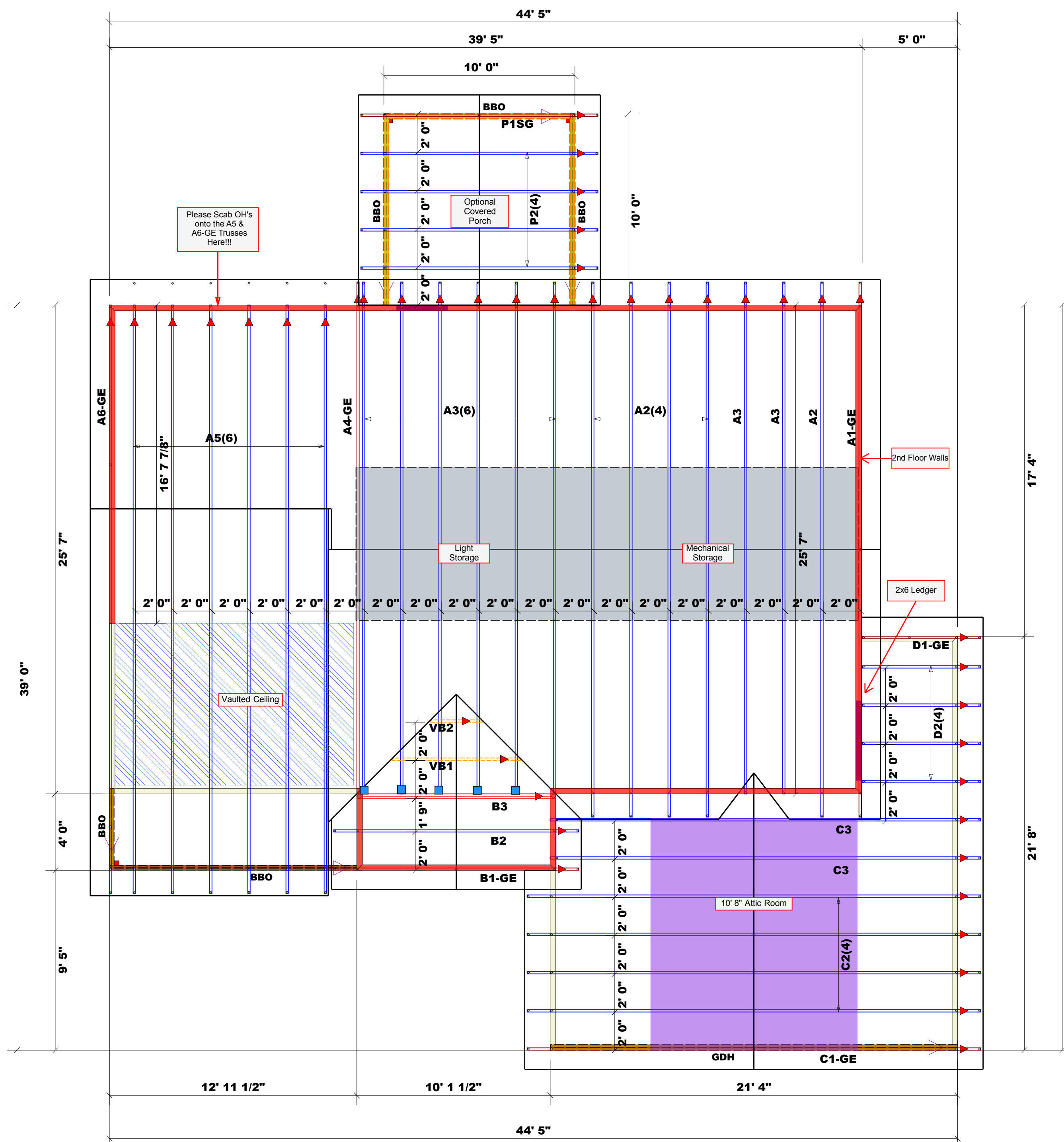

Please Scab OH's onto the A5 & A6-GE Trusses Here!!!

Optional Covered Porch

2nd Floor Walls

2x6 Ledger

10' 8" Attic Room

BUILDER	JOB NAME	PLAN	SEAL DATE	QUOTE #	JOB #
Precision Custom Homes	Lot 35 Liberty Meadows	Rand 1.0	N/A	N/A	J0823-4324

COUNTY	ADDRESS	MODEL	DATE REV.	DRAWN BY	SALESMAN
Harnett	16 Hancock Ct., Cameron, NC	Roof	8/12/2023	Neil Baggett	Neil Baggett

THIS IS A TRUSS PLACEMENT DIAGRAM ONLY. These trusses are designed as individual building components to be incorporated into the building design at the specification of the building designer. See individual design sheets for each truss design identified on the placement drawing. The building designer is responsible for temporary and permanent bracing of the roof and floor system and for the overall structure. The design of the truss support structure including headers, beams, walls, and columns is the responsibility of the building designer. For general guidance regarding bracing, consult BCSI-B1 and BCSI-B3 provided with the truss delivery package or online @ sbcindustry.com

North Carolina 2018 - R402.1.5 Total UA



Property

16 Hancock Ct
Cameron, NC 28326
Model: Rand
Community: Liberty Meadows

Organization

Southern Energy Manager
Justin Smith

Inspection Status

Results are projected

Builder

SMG Precision Properties

Template - SMG Precision - Liberty Meadows Lot 35 - CZ 4 slab - Liberty Meadows Lot 35

This report is based on a proposed design and does not confirm field enforcement of design elements.

Building UA

Elements	NC Reference	As Designed
Ceilings	38.6	36.7
Above-Grade Walls	177.6	131.8
Windows, Doors and Skylights	89.6	79.3
Slab Floor:	65.9	85.5
Framed Floors	13.4	14.6
Foundation Walls	0.0	0.0
Rim Joists	7.1	5.7
Overall UA (Design must be equal or lower):	392.2	353.6

Requirements

✓	R402.1.5	Total UA alternative compliance passes by 9.8%. The proposed home meets the UA requirement by 9.8%
✓	402.3.2	Average SHGC: 0.28 Max SHGC: 0.30 Average SHGC of 0.28 is greater than the maximum of 0.30.
✓	R402.4.2.2	Air Leakage Testing Air sealing is 0.28 CFM50 / ft² Shell Area. It must not exceed 0.30 CFM50 / ft² Shell Area.
✓	R402.5	Area-weighted average fenestration SHGC Area-weighted average fenestration SHGC is 0.28. The maximum allowed value is [No Limit].
✓	R402.5	Area-weighted average fenestration U-Factor
✓	R404.1	Lighting Equipment At least 75.0% of fixtures shall be high-efficacy lamps, currently 90.0% are high-efficacy.
✓	Mandatory Checklist	Mandatory code requirements that are not checked by Ekotrope must be met. 2015 IECC Mandatory Checklist must be checked as complete.
✓	R403.3.1	Duct Insulation Duct insulation meets the requirements specified in North Carolina 2018 Code Section 403.3.1.
✓	403.3.3	Duct Testing

Design exceeds requirements for North Carolina 2018 Prescriptive compliance by 9.8%.

Name: Justin Smith

Signature: Justin Smith

Organization: Southern Energy Management

Digitally signed: 8/17/23 at 11:42 AM

Ekotrope RATER - Version 4.1.0.3222

North Carolina 2018 Prescriptive compliance results calculated using Ekotrope RATER's energy and code compliance algorithm, including appropriate amendments. Ekotrope RATER is a RESNET Accredited HERS Rating Tool. All results are based on data entered by Ekotrope users. Ekotrope disclaims all liability for the information shown on this report.

Building Summary



Property
 16 Hancock Ct
 Cameron, NC 28326
 Model: Rand
 Community: Liberty Meadows

Organization
 Southern Energy Management
 Justin Smith

Inspection Status
 Results are projected

Builder
 SMG Precision Properties

Template - SMG Precision - Liberty Meadows Lot 35
 - CZ 4 slab - ecoSelect
 Liberty Meadows Lot 35

General Building Information

Number Of Bedrooms	4
Number Of Floors	2
Conditioned Floor Area [sq. ft.]	2,075
Has Electric Vehicle Ready Space	No
Unconditioned, attached garage?	Yes
Conditioned Volume [cu. ft.]	18,602
Total Units in Building	1
Residence Type	Single family detached
Number of Floors in Building	-
Floor Number	-
Model	Rand
Community	Liberty Meadows
RESNET/IECC 2006-2018 Climate Zone	4A
IECC 2021 Climate Zone	3A

Foundation Wall

None Present

Foundation Wall Library List

None Present

Slab

Name	Library Type	Perimeter	Floor Grade	Carpet R	Exposed Masonry Area	Surface Area	Location	Enclosing
slab	Uninsulated	138	On Grade	1	0	1,001.0 ft²	Exposed Exterior	Conditioned Space

Slab Library List

Name	Wall Construction Type	Slab Completely Insulated?	Underslab Insulation Width [ft]	Perimeter Insulation Depth [ft]	Perimeter Insulation R Value	Perimeter Insulation Is Exterior	Thermal Break	Effective R-value
Uninsulated	Wood Frame / Other	No	0	0	0	Yes	No	0.00

Building Summary



Property
 16 Hancock Ct
 Cameron, NC 28326
 Model: Rand
 Community: Liberty Meadows

Organization
 Southern Energy Management
 Justin Smith

Inspection Status
 Results are projected

Builder
 SMG Precision Properties

Template - SMG Precision - Liberty Meadows Lot 35
 - CZ 4 slab - ecoSelect
 Liberty Meadows Lot 35

Framed Floor

Name	Library Type	Carpet R	Floor Grade	Surface Area	Location
over garage	R 19, 16"OC G1 Carpet	0	Above Grade	286.0 ft ²	Unconditioned, attached garage

Framed Floor Library List

Name	Effective R-value
R 19, 16"OC G1 Carpet	19.566

Rim Joist

Name	Library Type	Surface Area	Location
1st floor ambient	R 19 G1, 16"OC	100.0 ft ²	Exposed Exterior
1st floor garage	R 19 G1, 16"OC	28.0 ft ²	Unconditioned, attached garage

Rim Joist Library List

Name	Effective Insulation R-value
R 19 G1, 16"OC	17.30

Wall

Name	Library Type	Surface Color	Surface Area	Location
1st floor ambient	R 19 Adv. Framing G1 16" O.C	Medium	993.0 ft ²	Exposed Exterior
1st floor garage	R 19 Adv. Framing G1 16" O.C	Medium	249.0 ft ²	Unconditioned, attached garage
2nd floor ambient	R 19 Adv. Framing G1 16" O.C	Medium	800.0 ft ²	Exposed Exterior
2nd floor attic	R 19 Adv. Framing G1 16" O.C	Medium	520.0 ft ²	Attic

Building Summary



Property
 16 Hancock Ct
 Cameron, NC 28326
 Model: Rand
 Community: Liberty Meadows

Organization
 Southern Energy Management
 Justin Smith

Inspection Status
 Results are projected

Builder
 SMG Precision Properties

Template - SMG Precision - Liberty Meadows Lot 35
 - CZ 4 slab - ecoSelect
 Liberty Meadows Lot 35

Wall Library List

Name	Effective R-value
R 19 Adv. Framing G1 16" O.C	17.492

Glazing

Name	Library Type	Wall Assignment	Foundation Wall Assignment	Is Operable	Overhang Depth	Overhang Ft To Top	Overhang Ft To Bottom	Orientation	Surface Area
front 2nd unshaded	33/28	2nd floor ambient		Yes	0	0	0	West	40.5 ft ²
front shaded	33/28	1st floor ambient		Yes	5	1	5	West	10.8 ft ²
front unshaded	33/28	1st floor ambient		Yes	0	0	0	West	27.0 ft ²
left unshaded	33/28	1st floor ambient		Yes	0	0	0	North	20.0 ft ²
rear 2nd unshaded	33/28	2nd floor ambient		Yes	0	0	0	East	54.0 ft ²
rear unshaded	33/28	1st floor ambient		Yes	0	0	0	East	57.8 ft ²
right unshaded	33/28	1st floor ambient		Yes	0	0	0	South	6.0 ft ²

Glazing Library List

Name	Shgc	U-factor
33/28	0.28	0.330

Skylight

None Present

Skylight Library List

None Present

Building Summary



Property
 16 Hancock Ct
 Cameron, NC 28326
 Model: Rand
 Community: Liberty Meadows

Organization
 Southern Energy Management
 Justin Smith

Inspection Status
 Results are projected

Builder
 SMG Precision Properties

Template - SMG Precision - Liberty Meadows Lot 35
 - CZ 4 slab - ecoSelect
 Liberty Meadows Lot 35

Opaque Door

Name	Library Type	Wall Assignment	Foundation Wall Assignment	Emittance	Solar Absorptance	Surface Color	Surface Area	Location
front entry	Fiberglass R-5	1st floor ambient		0.9	0.75	Medium	20.0 ft²	Exposed Exterior
garage entry	Fiberglass R-5	1st floor garage		0.9	0.75	Medium	20.0 ft²	Unconditioned, attached garage

Opaque Door Library List

Name	Effective U-factor
Fiberglass R-5	0.200

Roof Insulation

Name	Library Type	Attic Exterior Area [ft²]	Clay or Concrete Roof Tiles	Surface Color	Surface Area	Location
attic	R 38 Attic BLOWN FG G1 2x10 24"OC NO Radiant Barrier	1,891.89	No	Dark	1,287.0 ft²	Attic

Roof Insulation Library List

Name	Has Radiant Barrier	Effective R-value
R 38 Attic BLOWN FG G1 2x10 24"OC NO Radiant Barrier	No	35.115

Whole House Infiltration

Infiltration	Measurement Type	Shelter Class
1488 CFM at 50 Pa	Blower-door tested	4

Mechanical Ventilation

None Present

Building Summary



Property
16 Hancock Ct
Cameron, NC 28326
Model: Rand
Community: Liberty Meadows

Organization
Southern Energy Management
Justin Smith

Inspection Status
Results are projected

Builder
SMG Precision Properties

Template - SMG Precision - Liberty Meadows Lot 35
- CZ 4 slab - ecoSelect
Liberty Meadows Lot 35

Lighting

% Interior Fluorescent Lighting	% Interior LED Lighting	% Exterior Fluorescent Lighting	% Exterior LED Lighting	% Garage Fluorescent Lighting	% Garage LED Lighting
0	90	0	0	0	0

Onsite Generation

None Present

Onsite Generation Library List

None Present

Solar Generation

None Present

Dehumidifier

None Present

Dehumidifier Library List

None Present

Whole House Fan

None Present

Building Summary



Property
 16 Hancock Ct
 Cameron, NC 28326
 Model: Rand
 Community: Liberty Meadows

Organization
 Southern Energy Management
 Justin Smith

Inspection Status
 Results are projected

Builder
 SMG Precision Properties

Template - SMG Precision - Liberty Meadows Lot 35
 - CZ 4 slab - ecoSelect
 Liberty Meadows Lot 35

Whole House Fan Library List

None Present

Conditioning Equipment

Name	Library Type	Serial Number	Heating Percent Load	Cooling Percent Load	Hot Water Percent Load	Location
1st floor heat pump	z 24k 14 SEER 8.0hspf		48%	48%	0%	Attic
2nd floor heat pump	z 24k 14 SEER 8.0hspf		52%	52%	0%	Attic
Water Heating	z 50 gal. 0.95 EF Elec		0%	0%	100%	Unconditioned Garage

Equipment Type: z 24k 14 SEER 8.0hspf

Equipment Type	Air Source Heat Pump
Fuel Type	Electric
Distribution Type	Forced Air
Motor Type	PSC (Single Speed)
Heat Pump System Type	Unspecified
Heating Efficiency	8 HSPF
Heating Capacity [kBtu/h]	24
Backup Fuel Type	Electric
Switchover Temperature [°F]	0
Backup Heating Efficiency	1 COP
Use default Supplemental Heat	Yes
Cooling Efficiency	14 SEER
Cooling Capacity [kBtu/h]	24

Equipment Type: z 24k 14 SEER 8.0hspf

Equipment Type	Air Source Heat Pump
Fuel Type	Electric
Distribution Type	Forced Air
Motor Type	PSC (Single Speed)
Heat Pump System Type	Unspecified
Heating Efficiency	8 HSPF
Heating Capacity [kBtu/h]	24
Backup Fuel Type	Electric
Switchover Temperature [°F]	0
Backup Heating Efficiency	1 COP
Use default Supplemental Heat	Yes
Cooling Efficiency	14 SEER
Cooling Capacity [kBtu/h]	24

Building Summary



Property
 16 Hancock Ct
 Cameron, NC 28326
 Model: Rand
 Community: Liberty Meadows

Organization
 Southern Energy Management
 Justin Smith

Inspection Status
 Results are projected

Template - SMG Precision - Liberty Meadows Lot 35
 - CZ 4 slab - ecoSelect
 Liberty Meadows Lot 35

Builder
 SMG Precision Properties

Equipment Type: z 50 gal. 0.95 EF Elec

Equipment Type	Residential Water Heater
Fuel Type	Electric
Distribution Type	Hydronic Delivery (Radiant)
Hot Water Efficiency	0.95 Energy Factor
Tank Capacity (gal.)	50
Hot Water Capacity [kBtu/h]	40
Recovery Efficiency	0.98

Distribution System

Distribution Type	Forced Air
Heating Equipment	1st floor heat pump
Cooling Equipment	1st floor heat pump
Sq. Feet Served	1,001
# Return Grilles	2
Supply Duct R Value	8
Return Duct R Value	8
Supply Duct Area [ft ²]	270.27
Return Duct Area [ft ²]	100.1
Leakage to Outdoors	40 CFM @ 25Pa (4 / 100 ft ²)
Total Leakage	40 CFM25
Total Leakage Duct Test Conditions	Post-Construction
Use Default Flow Rate	Yes
Duct 1	
Duct Location	Attic (well vented)
Percent Supply Area	70
Percent Return Area	70
Duct 2	
Duct Location	Conditioned Space
Percent Supply Area	30
Percent Return Area	30
Duct 3	
Duct Location	Conditioned Space
Percent Supply Area	0
Percent Return Area	0
Duct 4	
Duct Location	Conditioned Space
Percent Supply Area	0
Percent Return Area	0
Duct 5	
Duct Location	Conditioned Space
Percent Supply Area	0
Percent Return Area	0
Duct 6	
Duct Location	Conditioned Space
Percent Supply Area	0
Percent Return Area	0

Building Summary



SOUTHERN ENERGY
MANAGEMENT
ENERGY EFFICIENCY & SOLAR POWER

Property
16 Hancock Ct
Cameron, NC 28326
Model: Rand
Community: Liberty Meadows

Organization
Southern Energy Management
Justin Smith

Inspection Status
Results are projected

Builder
SMG Precision Properties

Template - SMG Precision - Liberty Meadows Lot 35
- CZ 4 slab - ecoSelect
Liberty Meadows Lot 35

Distribution System

Distribution Type	Forced Air
Heating Equipment	2nd floor heat pump
Cooling Equipment	2nd floor heat pump
Sq. Feet Served	1,074
# Return Grilles	2
Supply Duct R Value	8
Return Duct R Value	8
Supply Duct Area [ft ²]	289.98
Return Duct Area [ft ²]	107.4
Leakage to Outdoors	42 CFM @ 25Pa (3.91 / 100 ft ²)
Total Leakage	42 CFM25
Total Leakage Duct Test Conditions	Post-Construction
Use Default Flow Rate	Yes
Duct 1	
Duct Location	Attic (well vented)
Percent Supply Area	100
Percent Return Area	100
Duct 2	
Duct Location	Conditioned Space
Percent Supply Area	0
Percent Return Area	0
Duct 3	
Duct Location	Conditioned Space
Percent Supply Area	0
Percent Return Area	0
Duct 4	
Duct Location	Conditioned Space
Percent Supply Area	0
Percent Return Area	0
Duct 5	
Duct Location	Conditioned Space
Percent Supply Area	0
Percent Return Area	0
Duct 6	
Duct Location	Conditioned Space
Percent Supply Area	0
Percent Return Area	0

HVAC Grading

HVAC Grading Not Conducted

Ceiling Fan

Has Ceiling Fan	No
Cfm Per Watt	100

Building Summary



Property
16 Hancock Ct
Cameron, NC 28326
Model: Rand
Community: Liberty Meadows

Organization
Southern Energy Management
Justin Smith

Inspection Status
Results are projected

Template - SMG Precision - Liberty Meadows Lot 35
- CZ 4 slab - ecoSelect
Liberty Meadows Lot 35

Builder
SMG Precision Properties

Water Distribution

Water Fixture Type	Low-flow
Use Default Hot Water Pipe Length	No
Hot Water Pipe Length [ft]	84
At Least R3 Pipe Insulation?	No
Hot Water Recirculation System?	No
Recirculation System Pipe Loop Length [ft]	20
Drain Water Heat Recovery?	No

Clothes Dryer

Cef	3.01
Fuel Type	Electric
Field Utilization	Timer Controls
Is Outside Conditioned Space	No
Clothes Dryer Available	Yes
Defaults Type	HERS Reference

Clothes Washer

Label Energy Rating	153 kWh/Year
Annual Gas Cost	\$12.00
Electric Rate	\$0.11/kWh
Gas Rate	\$1.22/Therm
Capacity	3.31
Imef	2.1547
Defaults Type	Custom
Load Type	Front-load
Loads Per Week	6
Is Outside Conditioned Space	No
Clothes Washer Available	Yes

Dishwasher

Dishwasher Efficiency	270 kWh
Dishwasher Size	Standard
Annual Gas Cost	\$22.23
Electric Rate	\$0.12/kWh
Gas Rate	\$1.09/Therm
Is Outside Conditioned Space	No

Building Summary



Property
16 Hancock Ct
Cameron, NC 28326
Model: Rand
Community: Liberty Meadows

Organization
Southern Energy Management
Justin Smith

Inspection Status
Results are projected

Template - SMG Precision - Liberty Meadows Lot 35
- CZ 4 slab - ecoSelect
Liberty Meadows Lot 35

Builder
SMG Precision Properties

Appliances and Controls

Thermostat Cooling Setpoint	**** 75.0
Thermostat Heating Setpoint	**** 70.0
Range/Oven Fuel	Electric
Convection Oven?	No
Induction Range?	No
Range/Oven Outside Conditioned Space?	No
Refrigerator Consumption	538 kWh/Year
Refrigerator Outside Conditioned Space?	No

Notes

Initial Inputs _____ JS 08/17/23 _____

- confirm HVAC specs
- confirm water heater specs
- confirm ventilation entry
- modeled to worst case orientation
- confirm cfl lighting %



ROOF & FLOOR TRUSSES & BEAMS

Reilly Road Industrial Park
Fayetteville, N.C. 28309
Phone: (910) 864-8787
Fax: (910) 864-4444

Bearing reactions less than or equal to 3000# are deemed to comply with the prescriptive Code requirements. The contractor shall refer to the attached Tables (derived from the prescriptive Code requirements) to determine the minimum foundation size and number of wood studs required to support reactions greater than 3000# but not greater than 15000#. A registered design professional shall be retained to design the support system for any reaction that exceeds those specified in the attached Tables. A registered design professional shall be retained to design the support system for all reactions that exceed 15000#.

Signature _____
Neil Baggett

LOAD CHART FOR JACK STUDS

(BASED ON TABLES R502.5(1) & (b))

NUMBER OF JACK STUDS REQUIRED @ EA END OF HEADER/GIRDER		NUMBER OF JACK STUDS REQUIRED @ EA END OF HEADER/GIRDER		NUMBER OF JACK STUDS REQUIRED @ EA END OF HEADER/GIRDER	
END REACTION (UP TO)	REQ. D. STUDS FOR (1) X 1/2" HEADER	END REACTION (UP TO)	REQ. D. STUDS FOR (1) X 1/2" HEADER	END REACTION (UP TO)	REQ. D. STUDS FOR (1) X 1/2" HEADER
1700	1	2550	1	3400	1
3400	2	5100	2	6800	2
5100	3	7650	3	10200	3
6800	4	10200	4	13600	4
8500	5	12750	5	17000	5
10200	6	15300	6		
11900	7				
13600	8				
15300	9				

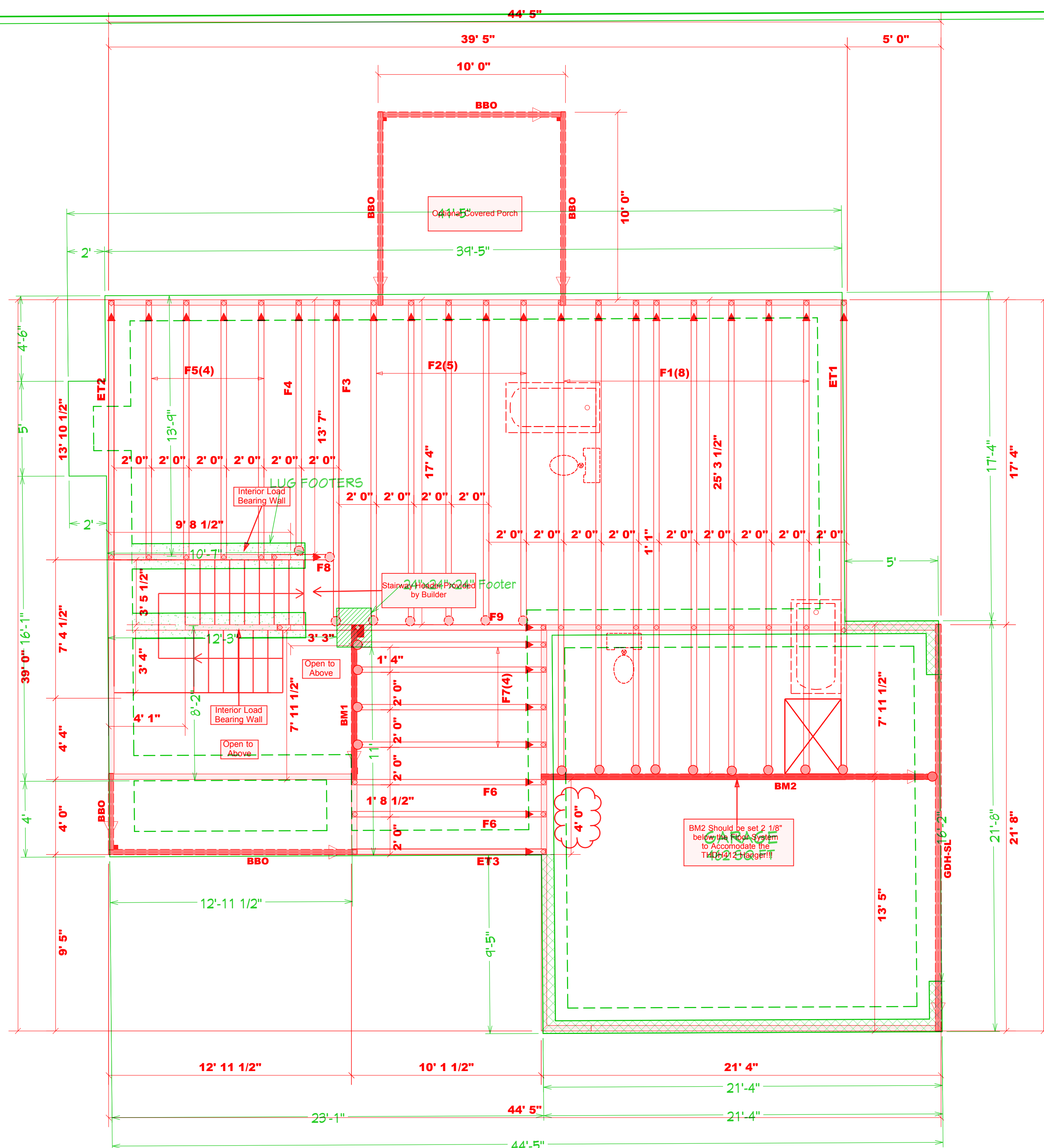

Dimension Notes

- All exterior wall to wall dimensions are to face of stud unless noted otherwise
- All interior wall dimensions are to face of stud unless noted otherwise
- All exterior wall to truss dimensions are to face of stud unless noted otherwise

Plumbing Drop Notes

- Plumbing drop locations shown are NOT exact.
- Contractor to verify ALL plumbing drop locations prior to setting Floor Trusses.
- Adjust spacing as needed not to exceed 24" oc.

Hatch Legend

- Vaulted Ceiling
- Padded HVAC
- 2nd Floor Walls @ 8' 1 1/2" UNO
- Drop Beam
- Flush Beam

Roof Area = 2204.59 sq.ft.
Ridge Line = 78.26 ft.
Hip Line = 0 ft.
Horiz. OH = 130.55 ft.
Raked OH = 214.53 ft.
Decking = 76 sheets

All Walls Shown Are Considered Load Bearing

▲ = Indicates Left End of Truss (Reference Engineered Truss Drawing)
Do Not Erect Trusses Backwards

1 Truss Placement Plan
Scale: 1/4"=1'

Connector Information				Nail Information		
Sym	Product	Manuf	Qty	Supported Member	Header	Truss
○	HUS410	USP	13	Varies	16d/3-1/2"	16d/3-1/2"
○	MSH422	USP	8	Varies	10d/3"	10d/3"
○	HUS26	USP	5	Varies	16d/3-1/2"	16d/3-1/2"
○	THDH412	USP	1	NA	16d/3-1/2"	16d/3-1/2"

DESIGNED BY: Precision Custom Homes, Raleigh, NC
Shaun@PrecisionCustomHomesNC.com

Products					
PlotID	Length	Product	Pies	Net Qty	Fab
GDH-SL	22'-0"	1-7/8" X 24" Kerto-S LVL 2.0E	2	2	FF
		1-3/4" X 23" Kerto-S	2	2	FF
		1-3/4" X 23" Kerto-S	2	2	FF

NAME	AREA
1st FLOOR	1,001 SF
2nd FLOOR	1,074 SF
GARAGE	422 SF
FRONT PORCH	51 SF
TOTAL HEATED	2,075 SF
TOTAL UNDER ROOF	2,548 SF

PLAN:
Rand

SHEET TITLE:
FOUNDATION

PROJECT ADDRESS:
**16 Hancock Ct.
Liberty Meadows Lot 35**

DESIGNED BY:
Precision Custom Homes
Raleigh, NC
Shaun@PrecisionCustomHomesNC.com

DATE:
8/15/23

SCALE:
1/4" = 1'

SHEET:

BUILDER	JOB NAME	PLAN	SEAL DATE	QUOTE #	JOB #
Precision Custom Homes	Lot 35 Liberty Meadows	Rand 1.0 w/GDH-SL	N/A	N/A	J0823-4325

COUNTY	ADDRESS	MODEL	DATE REV.	DRAWN BY	SALESMAN
Harnett	Lot 35 Liberty Meadows	Floor	8/12/2023	Neil Baggett	Neil Baggett

THIS IS A TRUSS PLACEMENT DIAGRAM ONLY.
These trusses are designed as individual building components to be incorporated into the building design at the specification of the building designer. See individual design sheets for each truss design identified on the placement drawing. The building designer is responsible for temporary and permanent bracing of the roof and floor system and for the overall structure. The design of the truss support structure including headers, beams, walls, and columns is the responsibility of the building designer. For general guidance regarding bracing, consult BCSI-B1 and BCSI-B3 provided with the truss delivery package or online @ sbciindustry.com

FOUNDATION PLAN