



July 14, 2023

Kirby Johnson
Johnson Farms
12232 US-70 Bus. West
Clayton, NC 27520
Ph: 919-369-7602

Reference: Engineering Services
4934 Red Hill Church Road
Coats, NC 27521
TE&D Project No.: 2301-020663

To Whom It May Concern;

As requested, a representative of Tyndall Engineering & Design, PA (TE&D) was on-site to observe the following items:

- 1) Inadequate footing projection at (2) piers within foundation.

The following conclusions and recommendations were noted:

- 1) Based on our visual observations and analysis, the existing foundation did not have a suitable projection of at minimum 2". It was observed that the footing was flush with at least (1) face of (2) piers at the left side of the foundation. TE&D recommends widening the existing footing in these locations per (1) of the details on page 3 of this report.

Upon completion, the modified foundation will provide the required support for the anticipated loading conditions. We appreciate being able to assist you during this phase of the project. If you need further assistance or require additional information, please do not hesitate to contact us.

Sincerely,
Tyndall Engineering & Design

Tripp Amos
PT III | 2301-020663

Prentice Tyndall Jr., P.E.

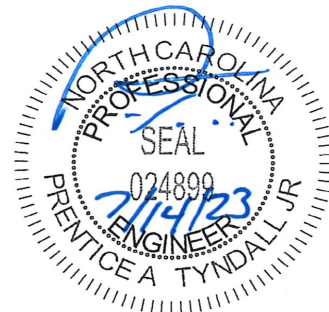



Examples and locations of piers with inadequate footing projection

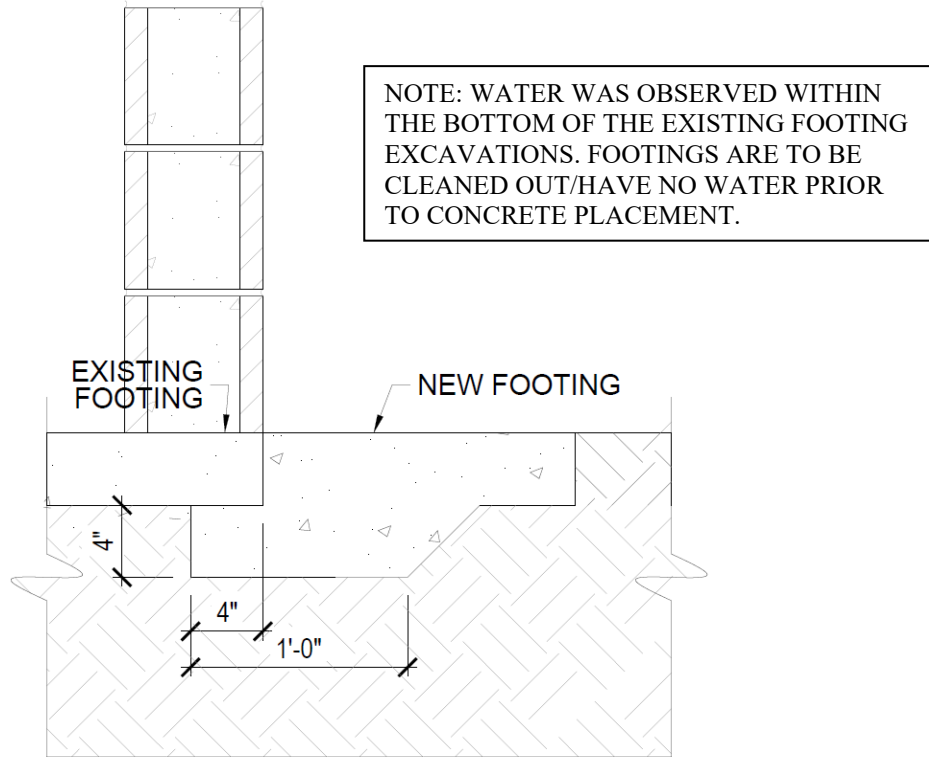

OPTION 1

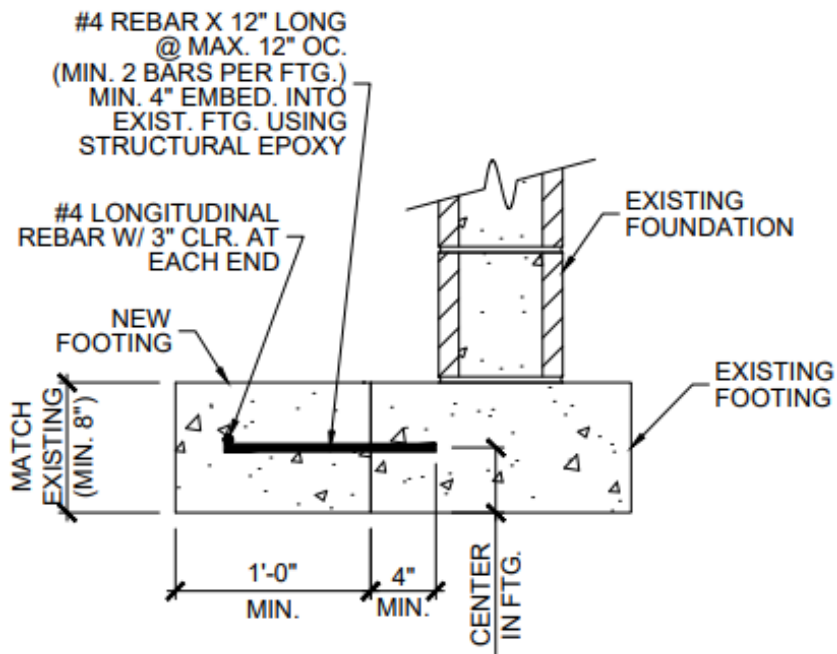

OPTION 2